

THIS BOOK IS THE PROPERTY OF H.M. GOVERNMENT

B.R.1617

Handbook for A.P. 57140 SERIES RECEIVER B40

ANY SUGGESTIONS FOR AMENDMENTS OR ADDITIONS TO THIS BOOK
SHOULD BE SUBMITTED TO THE CAPTAIN SUPERINTENDENT, A.S.R.E.,
THROUGH THE USUAL CHANNELS



RADIO EQUIPMENT DEPARTMENT · ADMIRALTY
MAY, 1956. (R.E. 384/56)

Receiver A.P. No.	Circuit Ref.	Description	A.P. No.	NSN
57140/A	SW201	<u>SWITCHES</u> Switch 3 Position, Bandwidth 4 Items (i) Wafer (ii) Wafer (iii) Wafer (iv) Mechanism	65631 65632 65633 65639	
57140B/C	SW201	Switch 3 Position, Bandwidth 5 Items (i) Wafer (ii) Wafer (iii) Wafer (iv) Wafer (v) Mechanism	65631 65632 65633 5930-A.P. 206820 5930-A.P. 206828	
57140D	SW201	Switch 3 Position, Bandwidth 5 Items (i) Wafer (ii) Wafer (iii) Wafer (iv) Wafer (v) Mechanism	65631 65632 5930-A.P. 206820 5930-A.P. 206821 5930-A.P. 206828	
57140/A	SW202	Switch 6 Position, System 4 Items (i) Wafer (ii) Wafer (iii) Wafer (iv) Mechanism	65634 65635 65636 65640	
57140B/C	SW202	Switch 5 Position, System 4 Items (i) Wafer (ii) Wafer (iii) Wafer (iv) Mechanism	65634 65635 65636 5930-A.P. 206829	
57140D	SW202	Switch 7 Position, System 5 Items (i) Wafer (ii) Wafer (iii) Wafer (iv) Wafer (v) Mechanism	5930-A.P. 206824 5930-A.P. 206825 5930-A.P. 206822 5930-A.P. 206823 5930-A.P. 206830	

B.R.1617 - HANDBOOK FOR A.P.57140 SERIES

RECEIVER B.40 - CHANGE NO. 6

(D.G.W.(N) - February, 1967)

Removal and Insertion Changes

Part 2, Chapter 8, Paragraph 18 (On reverse of Figure 5).

Remove and destroy leaf comprising Figure 5 and paragraph 18 and insert new leaf attached.

Manuscript Changes

Part 2, Chapter 6, Paragraph 3. In first line, after "trimming tool" insert "(A.P.71479 Trimming Tool)".

Part 3, Figure 10. Locate "R114" and "R120" and amend values to read "47 k".

Part 3, Components List for 57140D I.F. Unit (following Figure 16).

Amend A.P. number of R201 and R205 to read "022-3039".

Record the insertion of this Change on the Change Record Leaf at the beginning of B.R.1617.

Admiralty, S.W.1.

MAY, 1956

R.E. 384/56

B.R. 1617 "Handbook for A.P.57140 Series Receiver B40" having been approved by My Lords Commissioners of the Admiralty is hereby promulgated.

B.R. 1617 and Addendum "Handbook for Receiver B40, 1946" is hereby superseded and copies should be disposed of in accordance with instructions in B.R.1.

By Command of Their Lordships.



To:
Flag Officers and
Commanding Officers
of H.M. Ships and
Vessels concerned.

HANDBOOK FOR A.P.57140 SERIES, RECEIVER B40LIST OF CONTENTS

SUMMARY OF DATA

INTRODUCTION

PART 1

CHAPTER 1 OPERATING INSTRUCTIONS
CHAPTER 2 BRIEF TECHNICAL DESCRIPTION
CHAPTER 3 DETAILED CIRCUIT DESCRIPTION
CHAPTER 4 RECEIVER PATTERN DIFFERENCES

PART 2

CHAPTER 5 DISMANTLING THE RECEIVER
CHAPTER 6 ALIGNMENT
CHAPTER 7 PERFORMANCE TESTS
CHAPTER 8 REPAIR DATA FOR MARK 4 PLUGS AND SOCKETS
CHAPTER 9 REPAIR DATA, TUNING DRIVE MECHANISM

PART 3

ILLUSTRATIONS, COMPONENTS LISTS AND COIL DATA

SUMMARY OF DATA

PURPOSE

Receiver B40 is the main unit in Receiver Outfits CDW and CAQ fitted in H.M. Ships and R.N. Shore Wireless Stations respectively. Five versions of the receiver are in service - Patterns 57140/A/B/C and D.

TYPE OF RECEPTION

C.W. and A.M. Voice

Pattern 57140D is suitable for the reception of F.S.K.

FREQUENCY RANGE

Five ranges, giving continuous coverage from 650 kc/s to 30 Mc/s. Intermediate frequency - 500 kc/s.

PHYSICAL DATA

(Including resilient mounts and tray)	Height	Width	Depth	Weight
	19½"	13½"	16"	114 lb

BRIEF TECHNICAL DESCRIPTION

The receiver is divided into three separate units as follows:-

R.F. Unit (All patterns)

- Stage 1 R.F. Amplifier, incorporating anti-cross-modulation control and harmonic frequency feed from the B.F.O. for calibration purposes.
- Stage 2 R.F. Amplifier, A.G.C. voltage applied.
- Stage 3 Mixer, employing a separate oscillator which can be crystal controlled. Fine adjustment of oscillator is provided in Pattern 57140D.

Note: Patterns 57140C/D has the input circuit modified for Common Aerial Working.

I.F. Unit (Patterns 57140/A)Patterns 57140B/C/D

- | | | |
|---------|--|---|
| Stage 4 | I.F. Amplifier,
A.G.C. voltage applied. | I.F. Amplifier
A.G.C. voltage applied. |
| Stage 5 | I.F. Amplifier,
A.G.C. voltage applied. | I.F. Amplifier, with Crystal band-pass filter (1 kc/s)
A.G.C. voltage applied. |
| Stage 6 | I.F. Amplifier, second detector,
noise limiter and B.F.O. | I.F. Amplifier, second detector, noise limiter and
B.F.O. In D Pattern, B.F.O. is modified to give
additional "high" and "low" positions for F.S.K. work
on "wide" position. |

Note: The B.F.O. is crystal controlled for calibrating.



A.P. 57140/A

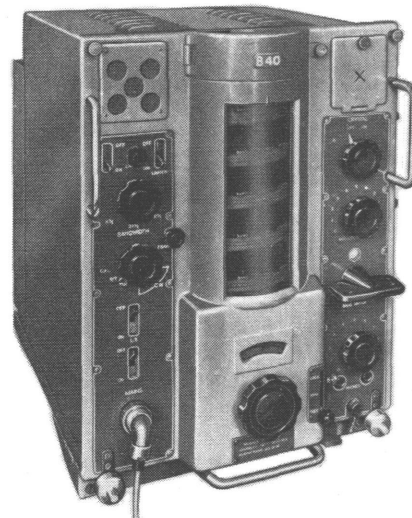

A.P. 57140B/C

A three position band-width switch allows for I.F. pass bands of 8 kc/s (wide) and 3 kc/s (narrow) in all patterns. The third position of this switch incorporates an audio note filter (band-pass 200 c/s, centre frequency 1000 c/s) in Patterns 57140/A; the 1 kc/s crystal band-pass filter is substituted in Patterns 57140B/C/D.

A.F. and Power Unit

Stage 7 A.F. Amplifier

Stage 8 Output.

Sensitivity:- Voice $4 \mu V$ for a 20 dB signal and noise to noise ratio.
C.W. $2 \mu V$ for a 20 dB signal and noise to noise ratio.

Selectivity:- Wide Band ± 4 kc/s for 6 dB.
Narrow Band ± 1.5 kc/s for 6 dB.
Crystal Filter ± 0.5 kc/s for 6 dB - Patterns 57140B/C/D only.

Image Rejection:- @ 23 Mc/s:- better than 40 dB.
@ 1.05 Mc/s:- better than 95 dB.

A.G.C. Performance:- For 80 dB change in input voltage, output change is less than 3.3 dB.

Noise Limiter:- Effective between modulation depths of 10% and 60%.

Max. Power Output:- Loudspeaker - 2.5 Watts.
Ship's control system - 35 mW.
Telephone - 14 mW.

Power Supply:- 115/230V 40/60 c/s A.C.
Power Consumption:- 80 Watts.

Facilities are available for connecting both low impedance (80 ohms) and high impedance aerials to Patterns 57140/A/B and low impedance aerials to Patterns 57140C/D. The aerial system normally comprises standard wire or whip aerials.

Pattern 57140D contains later type valves replacing the obsolescent types fitted in the earlier patterns.

B.R.1617.

E.935 (Ship) E.995 (Shore).

B.649 (Ship) B.705 (Shore).

I N T R O D U C T I O N

1. Receiver B40, covered in this Handbook, is available in several different forms (Admiralty Pattern No. 57140 Series), differing appreciably in technical detail. The book also covers Receivers 62B Patterns 67757 and 67757A which are basically the same as B40 but are primarily for S.R.E. use.
2. The bulk of the book therefore, covers the receiver in general terms, where possible. Where this is not possible, individual descriptions of features in the different types are given.
3. Related diagrams, drawings and illustrations are placed adjacent to the text to which they refer. Cross reference to other portions of the book is made by quoting the chapter and paragraph thus:-

2.5 or 5.8 (a)(iii).
4. In the Chapters dealing with Alignment Procedures and Performance Testing, different techniques have been laid down for use according to the complexity of the Test Equipment available. In general, only the simplest procedures are visualised as being undertaken in seagoing ships. Nevertheless, these should suffice to maintain the equipment at a very high standard of performance. The subject is fully covered in the introduction to the Chapters devoted to Alignment and Performance Measurement.
5. The circuit diagrams for the B40D receivers, have, in many cases, different circuit references to those shown in the equivalent diagrams for the other patterns, especially with regard to the R.F. Unit. Therefore descriptions of the B40D should be read only with reference to the circuit diagram concerned, for that pattern.
6. The five patterns of the B40 receivers are generally identified throughout the Handbook as B40, B40A, B40B, B40C and B40D, but for all other purposes it must be remembered that every receiver in the range is a B40 and that its type is indicated by the suffix to its pattern number.
7. Receivers B40, B40A and B40B are considered to be completely interchangeable, and any one of these may be replaced by a B40C or B40D. For common aerial working, B40C or B40D is necessary; only B40D provides facilities for f.s.k. reception.

PART 1

OPERATION AND TECHNICAL DESCRIPTION

CHAPTER 1OPERATING INSTRUCTIONSLIST OF CONTENTS

	<u>Para.</u>
Initial Setting-up	1
To tune in a required signal	2
To receive signals from a station	3
Function of other controls	4
External Connections	5

FIGURES

	<u>Fig.</u>
Receiver B4O. A.P. Nos. 57140/A - photograph	1
Receiver B4O. A.P. Nos. 57140B/C - photograph	2
Receiver B4O. A.P. Nos. 57140/D - photograph	3

CHAPTER 1
=====

OPERATING INSTRUCTIONS
=====

Initial Setting-Up - Figs. 1, 2 and 3

1. (1) Ensure that the output line is connected, if not, switch in the Dummy Load, i.e. switch toggle towards the front of the receiver.
- (2) Place the Mains Switch in the "ON" position. Until it has warmed up, there will be a tendency for the receiver to drift slightly off tune.
- (3) Limiter switch to "OFF".
- (4) Bandwidth switch to "NARROW" or "3 kc/s".
- (5) Crystal switch to "OFF".
- (6) Loudspeaker switch to "OFF". Use 'phones.
- (7) System switch to "TUNE".
- (8) Anti-Cross-Mod. Control fully clockwise.
- (9) A.G.C. switch (where fitted) to "ON".

To tune-in a required signal

- 2.(a) If the station has been "logged" and the precise setting on the logging scale is known, set the Band switch to the appropriate waveband and adjust the tuning control to the required logging scale position, search to and fro across this setting until the required station is heard. Tune very carefully to the "dead space" of the signal, then set the System Switch to the "HIGH" or "LOW" position, for the reception of c.w. signals, or to the "R/T" position for the reception of "Voice" signals.

NOTE: The HIGH and LOW positions of the System Switch are provided to clear "Adjacent Channel" interference when receiving c.w. signals. The position selected should be the one which gives greatest freedom from this type of interference.

See paragraph 3(g) for the full use of the System Switch.

- (b) If no logging scale setting for the required station is available, set the Wave-band Switch and Tuning control to the approximate tuning position. Then proceed as follows:-
 - (1) Set the System Switch to "CAL".
 - (2) Tune to the zero beat of the calibration mark (black spot) nearest to the required frequency.

- (3) Shift the tuning drum cursor, by means of the cursor adjustment, until the arrow in the centre lines up with the "dead space".
 - (4) Set the System Switch to "TUNE", and adjust the tuning control to the required frequency. Search to and fro over this setting until the station is heard. Tune very carefully to the "dead space" of the signal then set the System Switch to the "HIGH" or "LOW" position for the reception of c.w. signals, or to the R/T position for the reception of "Voice" signals.
 - (5) Record the logging scale reading.
- (c) As the operation of Receiver B4OD for f.s.k. reception involves indications on f.s.k. terminal equipment, it is not included in this handbook. Information is given in A.S.R.E. Note 3/55 - Introduction of Radio Teletype (R.A.T.T.) in H.M. Ships.
 - (d) Adjust gain controls as follows:-
 - (1) AF Gain to give a suitable level in the Remote Reception positions.
 - (2) Gain Control to give adequate level to operator's 'phones.

To receive signals from a station

3. The satisfactory reception of signals, whether Morse or Voice, whether or not in the presence of interference, jamming or fading, requires an understanding of the function of the various controls provided. A detailed explanation of the use of each control provided for this purpose, and its effect upon the incoming signal is given below:-

Crystal Switch

- (a) This switches in or out of circuit, a crystal whose function is to maintain the receiver accurately at a frequency determined by the crystal frequency. The crystal itself is housed in the Crystal Compartment. A pilot light shows behind a slot in the door of this compartment when the Crystal Switch is in the "ON" position.

Oscillator Trimming Control (B4OD only)

- (b) This is a fine tuning control for the local oscillator, enabling small adjustments to be made on either side of the normal setting. The scale has ten divisions marked 5 - 0 - 5, viewed through a window in the panel. This control is used for making fine tuning adjustments, particularly when receiving automatic telegraphy transmissions.

Anti-Cross-Modulation Control

- (c) This control is normally in the "fully clockwise" position, and is used when cross-modulation interference is encountered. This form of interference is rare, and may be recognised by the manner in which the interfering signal "rides" on the wanted signal. It ceases when the wanted signal ceases, e.g. between morse symbols, and cannot be removed by tuning re-adjustments. It can be minimised, and possibly eliminated, by rotating the Anti-Cross-Modulation Control to the point where the interference is least.

Limiter Switch (SW203) and Limiter Control (RV220)

- (d) Under conditions of severe interference, pulse or otherwise, the Limiter Switch (SW203) should be switched "ON". The amount of limitation imposed on the interference is effected by the Limiter Control (RV220). When the control is fully clockwise, limiting action is minimum. As the control is turned anti-clockwise, the amplitude of the interfering signals are reduced. The optimum position for this control is the point where interference cannot be reduced any further without undue distortion of the speech or (as in the case of morse signals) reducing the wanted signal also.

A.G.C. Switch (SW206) B4OB/C/D

- (e) This switch will normally be set to "ON", so that the a.g.c. circuit is operative. Only when a very weak signal is being received should it be necessary to switch off a.g.c. When switched "ON", the a.g.c. system levels out variations of signal strength due to fading, or variations of signal strength among ships operating on the same frequency. In the case of receivers B4O/A, a.g.c. is switched "ON" or "OFF" according to the position of the System Switch (SW202).

Bandwidth Switch (SW201)(f) B4O/A

- (i) This is a three position switch giving two positions of IF selectivity 8 kc/s and 3 kc/s. In the third position, the bandwidth remains at 3 kc/s, but an additional Note Filter with an effective audio bandwidth of approximately 200 c/s at 1 kc/s, is brought into circuit in the AF Unit. In the WIDE position, the b.f.o. circuit is inoperative.

B4OB/C/D

- (ii) A similar switch to that already described for the previous two patterns, is used to provide bandwidth positions of 8 kc/s, 3 kc/s and 1 kc/s. The third position is a 1 kc/s Crystal Filter circuit which replaces the Note Filter of the earlier patterns. The b.f.o. functions in all three positions.

System Switch (SW202)

- (g) This switch permits selection of the following positions:-

CAL

- (i) This is used when tuning-in a station which has not previously been logged. It permits the scale to be set accurately to the frequency in use. The receiver is tuned to the dead-space of the calibration signal nearest to the required signal frequency, and the cursor is rotated to the black spot denoting the calibration point in question.

R/T (Voice)

- (ii) This position is used when receiving Voice signals.

TUNE

- (iii) When tuning-in a station, this position is used. The tuning control should be adjusted to the dead-space of the required station. Subsequently, the System Switch should be set to R/T. for "Voice" signals, or to HIGH or LOW for morse signals.

HIGH or LOW

- (iv) When receiving morse, if interference from a station working on an adjacent channel is experienced, the switch should be set either to HIGH or LOW, according to which position affords the greatest freedom from interference. This is most effective on the 1 kc/s position.

MANUAL (B4O/A only)

- (v) The a.g.c. circuit is inoperative in this position. It should be used only when very strong interfering signals are experienced. Under these circumstances, if the a.g.c. circuits are in use, they will tend to produce such large a.g.c. voltages, that reception is blocked.

It must be remembered however, that in the MANUAL position, the b.f.o. is at 500 kc/s and will produce "dead space" tuning conditions if the wanted signal is tuned in accurately. The receiver must therefore be detuned slightly to ensure an audible note from the wanted signal.

F.S.K. Facilities (B4OD only)

- (vi) Two additional positions are provided on the System Switch for Frequency Shift Keying (FSK) reception. These are marked "FSK WIDE -HIGH-" and "FSK WIDE -LOW-" and are used for the reception of signals with a frequency shift of 200 - 1000 c/s. The HIGH and LOW c.w. positions remain the same (1000 c/s above and below the IF) and are also used for the FSK NARROW shift (0 - 200 c/s), so that the System Switch in this pattern has the following settings:-

Switch Position	System	
1	FSK WIDE	LOW
2	FSK WIDE	HIGH
3	FSK NARROW	LOW
4	FSK NARROW	HIGH
5	TUNE	
6	RT	
7	CAL	

} C.W.

AF Gain Control (RV224)

- (h) This control is normally set to give the required volume on the remote loudspeakers and 'phones connected to the control system. The degree of automatic control afforded by the a.g.c. system should ensure that variations in strength of incoming signals, will not often require a change in the setting of the AF Gain Control.

Gain Control (RV305/309)

- (j) (i) When the a.g.c. system is in use, this control affects only the loudness of the signal heard in the built-in loudspeaker or receiver telephones. It does not affect the level in the control system.
- (ii) When the a.g.c. is inoperative, i.e. in MANUAL or A.G.C. 'OFF', the overall signal level, both local and remote, is varied by this control.

4. The function of the other controls is as follows:-

Bandswitch

- (a) This is the turret switch which selects the appropriate coils for each waveband, at the same time illuminating the relevant dial scale.

Tuning Assembly

- (b) Tuning facilities are situated in the centre of the receiver and consist of the tuning drum, its associated cursor adjustment and dial locking device, logging scale and flywheel tuning drive; the knob being at the lower centre of the instrument. Tuning is by means of four ganged capacitors, one in each of the two RF amplifiers, the mixer, and local oscillator circuits. The drive operates the tuning drum through a 20:1 reduction gear box, a 3:1 reduction is made in the transmission to the ganged capacitors through a chain drive. Receivers B40B/C/D employ a modified drive incorporating a further gear box between the ganged capacitors and the chain drive. A stopping device at each end of the drive travel prevents damage to the ganged capacitors.

Tuning Drum

- (c) The five scales - one for each band - are positioned on the drum at a slight angle to the horizontal. As the drum rotates, the cursor rises or falls (depending on the direction of rotation) allowing two revolutions of the drum between the stops at the ends. Calibration points on the scales are indicated by dots, and the alignment reference points are indicated by a + sign.

Cursor Shift Control

- (d) This is a knurled wheel behind the curved hinged cover at the top of the central part of the front panel. It is used to enable the cursor to be aligned with the calibration marks on the tuning scales.

Dial Lock

- (e) Situated at the right hand side of the tuning knob, this lever controls a device for holding the tuning assembly in a particular setting. Loading springs prevent excessive pressure being placed on the locking mechanism. A thumb set screw at the side of the lever prevents it dropping under severe vibration.

Monitor Loudspeaker and Switch

- (f) This is used for local loudspeaker reception. It is switched "On" or "Off" by means of the Loudspeaker Switch, and can be used in circuit whether or not the external lines are connected. The audio output is relatively small, and care must be taken not to overload it by using excessively high settings of the gain control.

Telephone Jacks JK301/2

- (g) Headphones pattern W621, impedance 600 ohms, should be inserted into these jacks. Either two or three contact jack plugs may be used.

Earthing Terminal

- (h) This terminal is situated at the bottom right-hand side (as seen by the operator) of the receiver, below the 'phone jacks.

Dummy Load Switch SW204

- (j) It is essential that this switch is in the ON position, i.e. with the lever towards the front of the receiver, when the 600 ohms output line is not in use. The switch then connects a dummy load resistor of 620 ohms across this line. The switch is placed in the OFF position when a remote loudspeaker is connected in the line.

Scale Lamps Brilliance Control RV125 B40/A/B/C RV102 B40D

- (k) Part of this control is in series with the scale lamp selected by the Bandswitch and adjusts the brightness of the scale lamps.

NOTE: Controls described in (j) and (k) above, are at the back of the IF and RF Units.

External Connections

5. Power Supply

- (a) The power supply is fed to the receiver via a Mk. 4 plug and socket on the front panel.

The remainder of the external connections are made to the plugs and sockets on the brackets at the rear of the RF and IF units.

Aerial Input Plug PL101

- (b) This is a four pin Mark 4 plug, situated at the rear of the RF Unit. Pins B and C are used for the low impedance aerial inputs. A high impedance aerial may be connected to pin D in B40/A/B receivers only; there is no high impedance aerial input provided in B40C/D receivers. Pin A is earthed.

RIS Socket SK102 (SK101, B40D)

- (c) This is a coaxial type socket (rear of the RF Unit). Outputs from RIS Outfits can be applied to the receiver, through this plug.

REC Socket - SK202

- (d) This is a coaxial type socket, situated at the rear of the IF Unit. This IF Output can be used for Outfit REC.

REB Socket - SK203

- (e) This is a coaxial type socket, situated at the rear of the IF Unit. This socket is the one nearest to the RF Unit, and provides d.c. for use with Outfit REB.

Audio Output Plug - PL203 (PL202, B40D)

- (f) This is a Mark 4 six pole sealed type plug, providing three output channels as follows:-
- (i) Pins A and B deliver 2.5 watts into a 600 ohms line. This output is normally connected to a remote loudspeaker.
 - (ii) Pins C and D deliver 35 mW into a 600 ohms line from a separate winding on the transformer.
 - (iii) Pins E and F give an output of 14 mW into a 600 ohms line. They are an extension of the headphone and monitor loudspeaker circuits.
 - (iv) Pins A and F are earthed.

FIG. 1

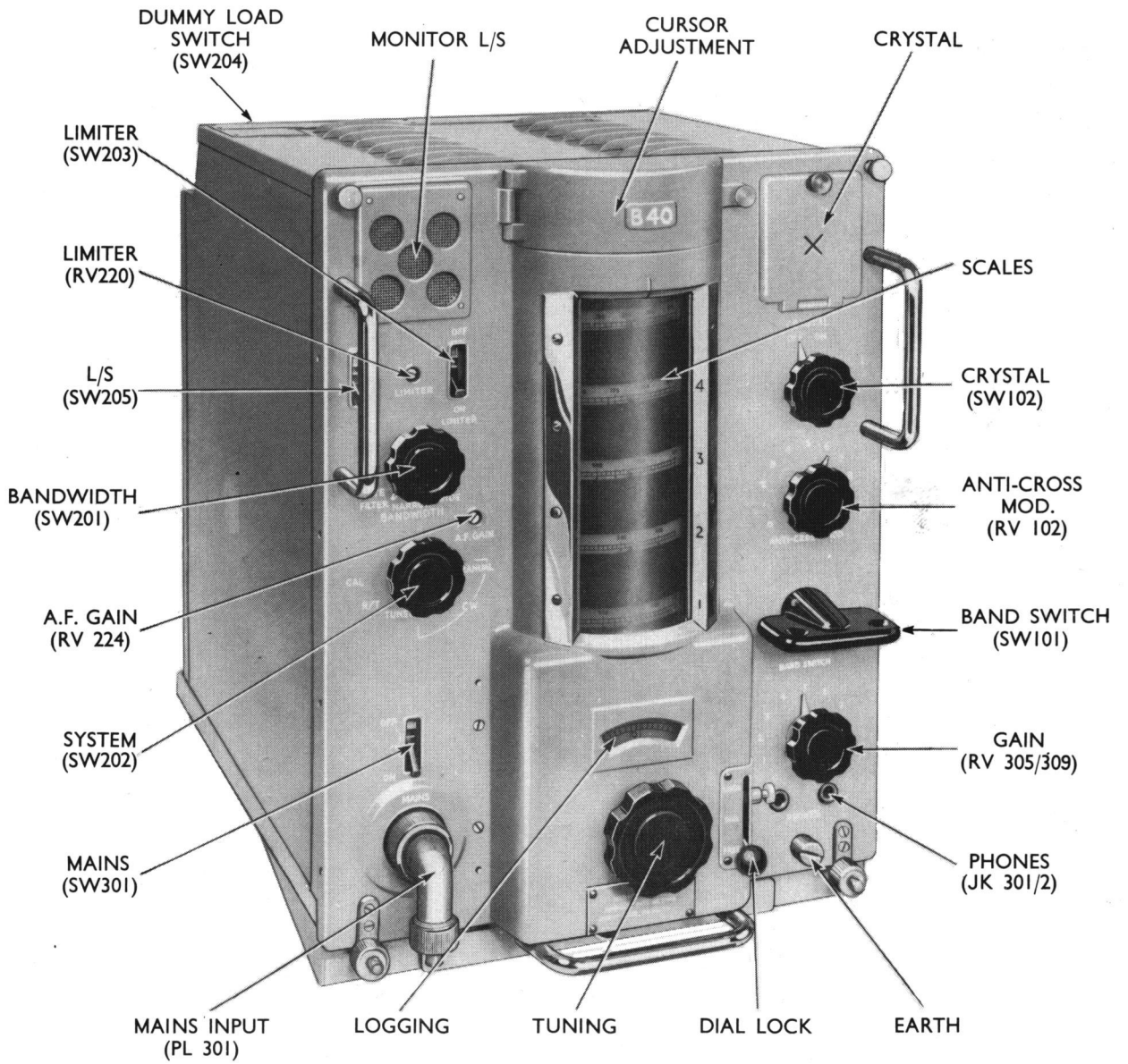

RECEIVER B.40
PATTERN 57140/A

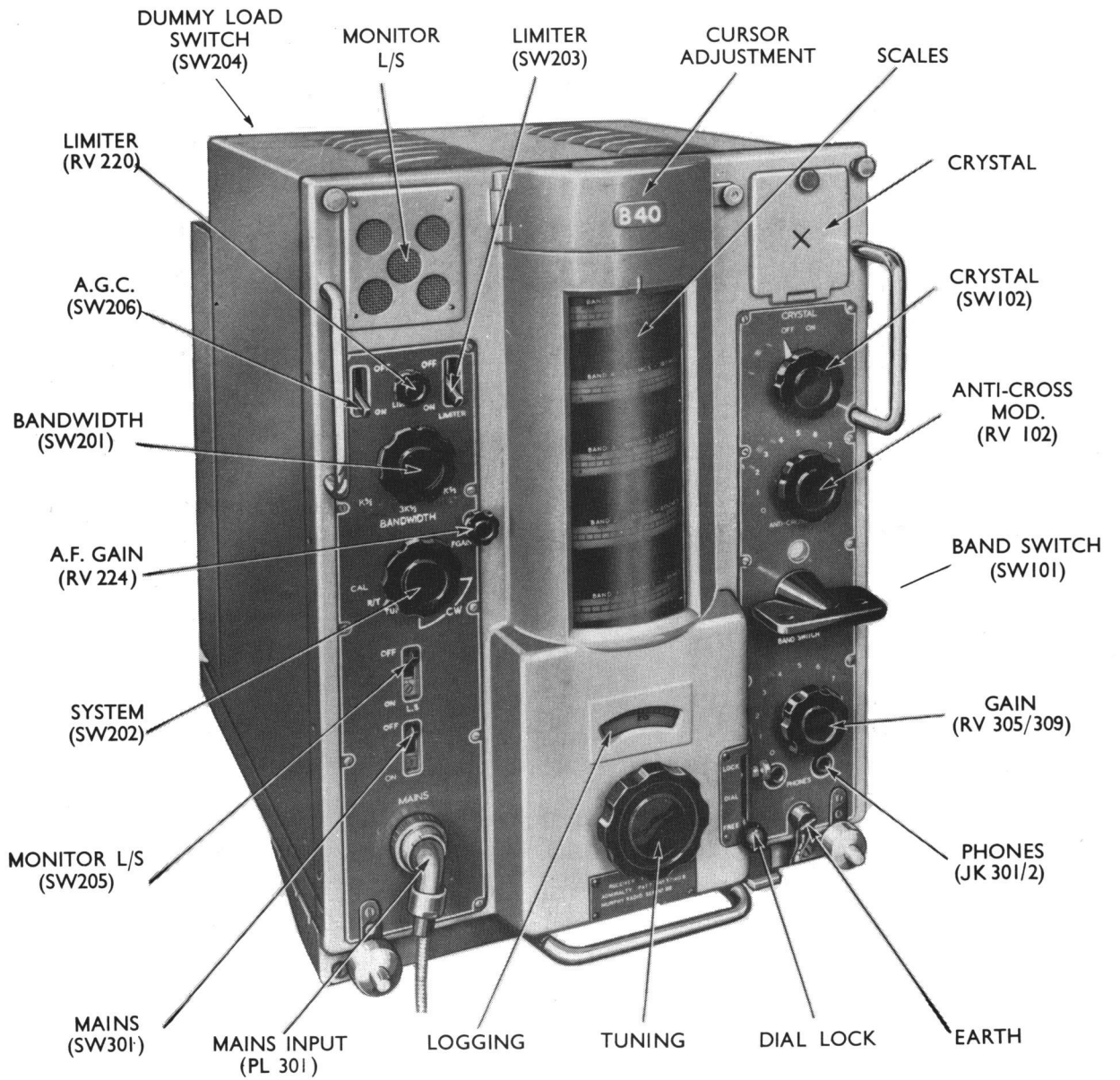

RECEIVER B.40
PATTERN 57140B/C

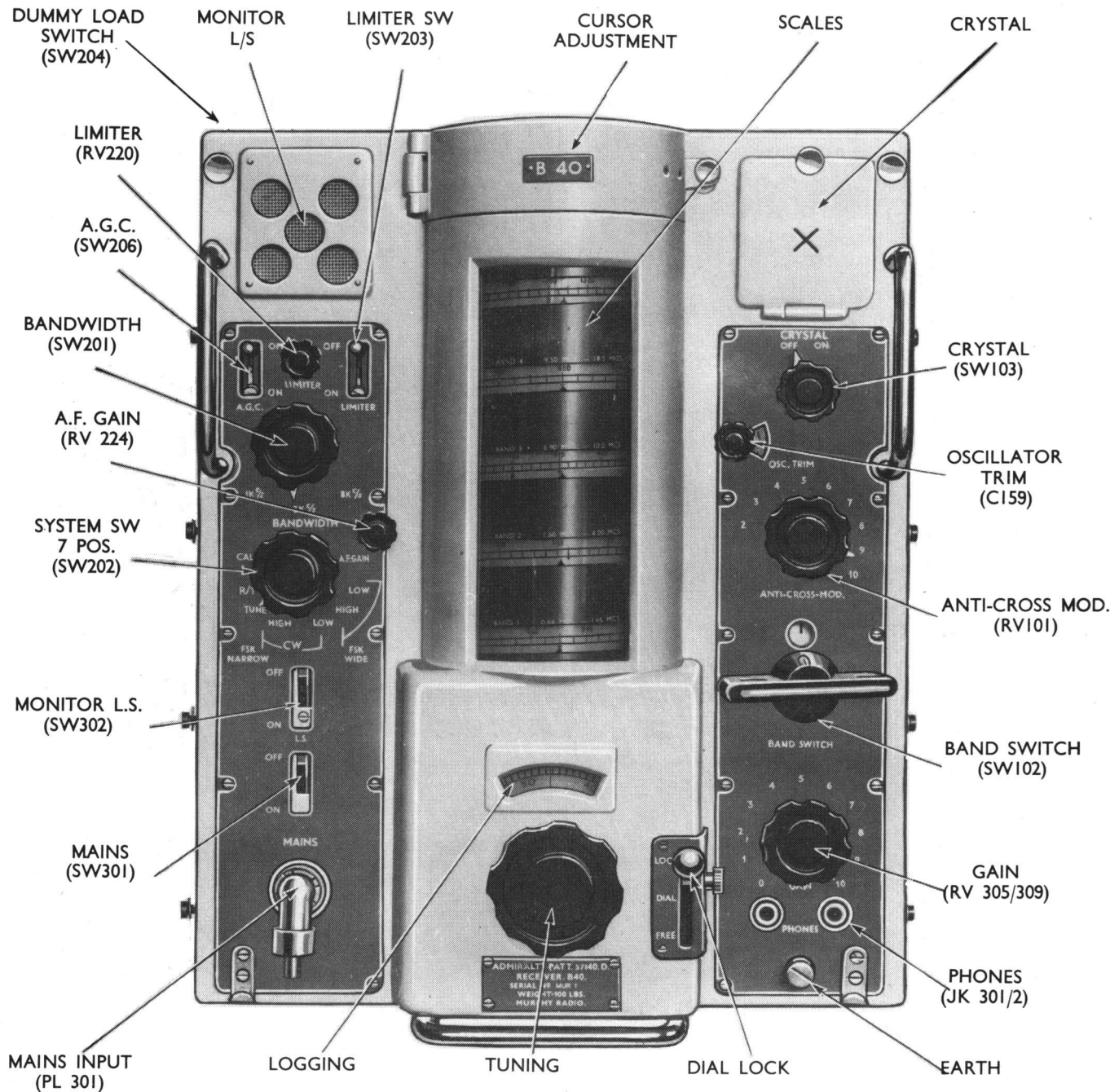

RECEIVER B40
PATTERN 57140D

CHAPTER 2BRIEF TECHNICAL DESCRIPTIONLIST OF CONTENTS

	<u>Para.</u>
Introduction	1-8
RF Unit	9
IF Unit	10
AF and Power Unit	11
Receiver 62B	12

FIGURES

Block Diagram showing inter unit connections - B4O/A/B/C	1
Block Diagram showing inter unit connections - B4OD	2

FIGS. 1 & 2

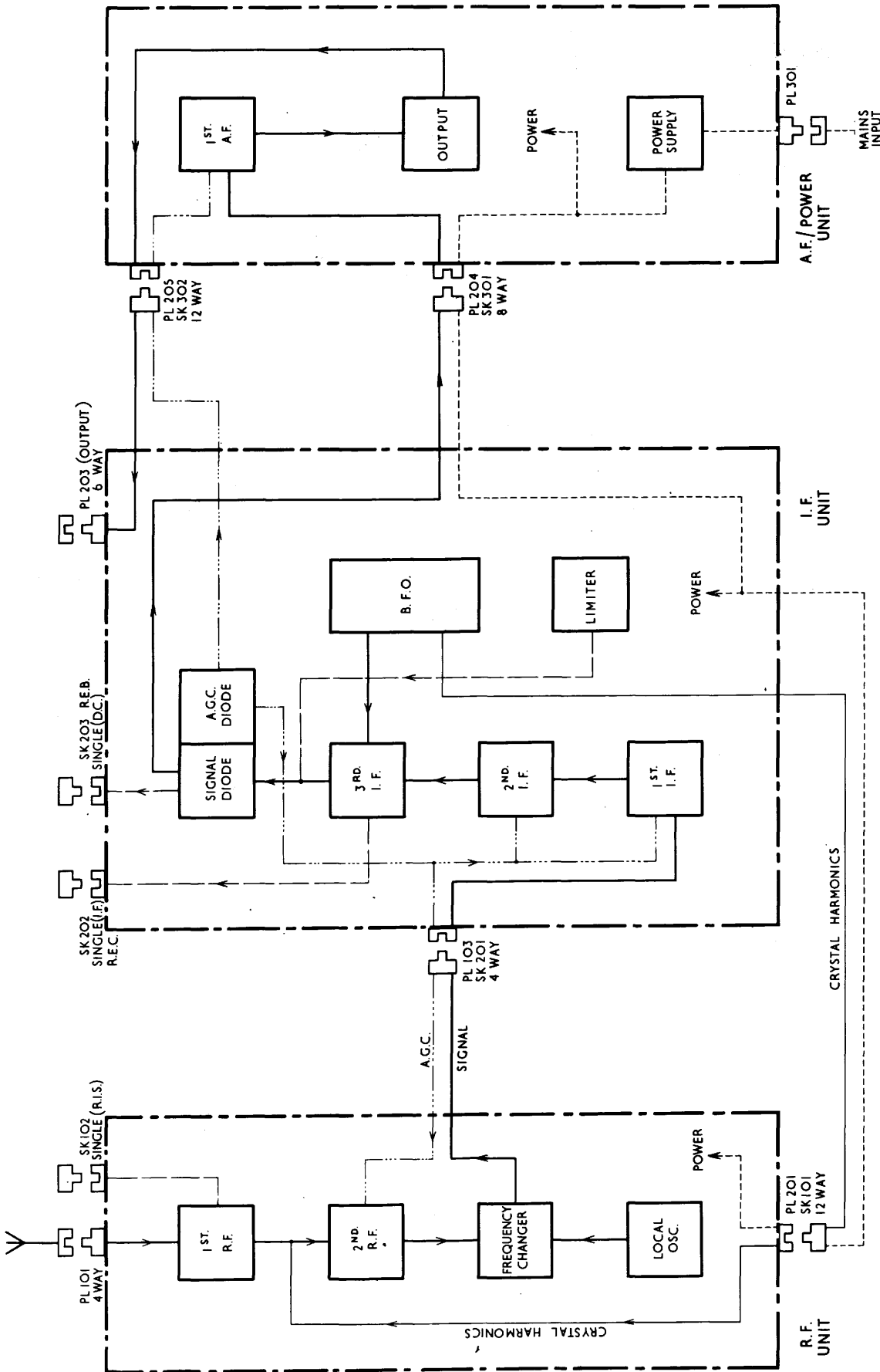

FIG. 1 BLOCK DIAGRAM SHOWING INTER UNIT CONNECTIONS
A.P. 57140/A/B/C

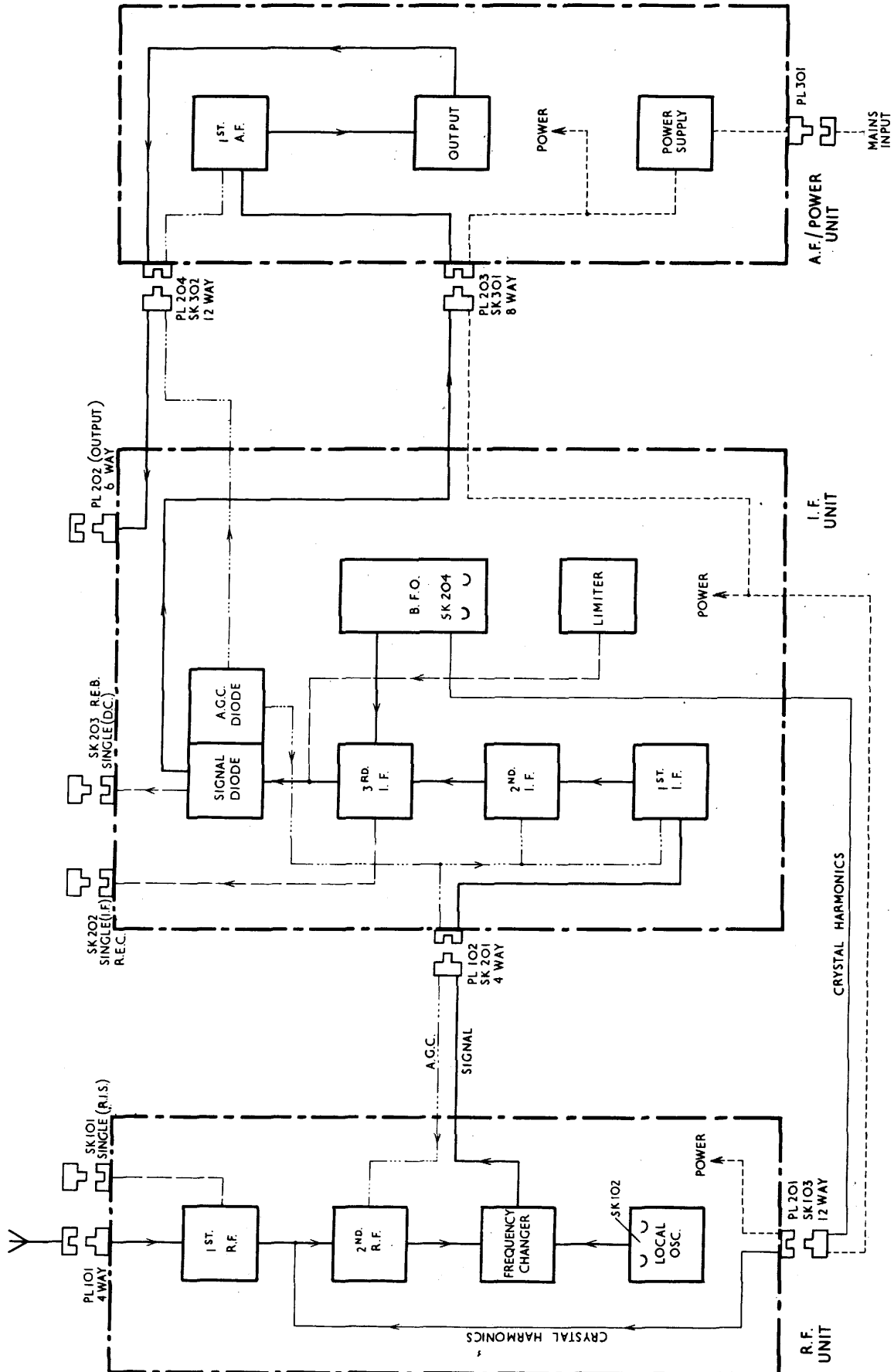

FIG. 2 BLOCK DIAGRAM SHOWING INTER UNIT CONNECTIONS
AP57140 D

CHAPTER 2BRIEF TECHNICAL DESCRIPTION

(Refer to Figs. 11, 12 and 13, Chapter 3)

Introduction

1. This section is devoted to a brief description at block diagram level of the arrangement and connections of the receiver. For a full detailed explanation of the circuitry, Chapter 3 (Detailed Circuit Description) should be read.
2. The receiver B40 is a conventional communications receiver for the reception of Voice, c.w. and f.s.k. signals in the frequency range 650 kc/s to 30 Mc/s. Five versions of the receiver are at present in service, and are identified under the pattern numbers 57140, 57140A, 57140B, 57140C and 57140D. These are customarily referred to, other than in Naval Store transactions, as B40, B40A, B40B, B40C and B40D. The main differences between the five versions are given below. For full details see Chapter 4.
 - B40. Original version.
 - B40A. Physical changes in the layout, mechanical changes to facilitate maintenance, and the substitution of improved components in certain cases.
 - B40B. Re-designed tuning drive, the addition of a crystal filter in the IF circuits, note filter deleted, A.G.C. switch fitted, System switch modified, mains transformer replaced, improved h.t. smoothing incorporated and a wave-band indicator fitted.
 - B40C. Modifications in the RF assembly to adapt the receiver for Common Aerial Working.
 - B40D. This receiver is fitted with preferred valves, which has made necessary some changes in the component values of the associated circuits. The b.f.o. and l.o. circuits are modified to adapt the receiver for f.s.k. reception. There are two extra b.f.o. pitch positions, for wide-band f.s.k. operation, thus the SYSTEM switch in this pattern has seven positions. The l.o. circuit is modified to incorporate a fine tuning control (OSC TRIM), which is fitted to the front panel. This trimmer gives a fine adjustment to the local oscillator tuning, to compensate for transmitter frequency drift.
3. The instrument is of unit construction, consisting of:- RF Unit, IF Unit, AF and Power Unit. These three units, each with their own controls, are inter-connected and mounted on the framework which fits into the receiver case. The tuning drive mechanism, and front panel are also mounted separately on this framework.

CHAPTER 2

4. The frequency range is covered in five bands, a turret switching arrangement selecting the required band. Switching to a particular band illuminates the appropriate scale. A logging scale is provided to facilitate re-setting the receiver to a particular frequency or station.
5. Facilities are provided for the following functions:-
 - (a) Matching the receiver to either a high impedance or low impedance aerial. (Low impedance only, in Receivers B4OC/D).
 - (b) Varying the selectivity by changing the bandwidth.
 - (c) Reduction of interference by use of a noise limiter.
 - (d) Reduction or elimination of cross-modulation interference.
 - (e) Provision of facilities for reception of:-
 - (i) C.W. } - by means of a beat frequency oscillator.
 - (ii) F.S.K. }
 - (iii) Voice (R/T)
selected by means of a SYSTEM SWITCH.
- This switch, in the CAL position, brings into operation a calibrator circuit which is used to check the setting accuracy of the scale.
- (f) Automatic gain control, to provide a reasonably constant level of audio frequency output, where the input signal or signals is not of constant strength.
- (g) Crystal control of the local oscillator when exceptional frequency stability is required.
- (h) Control of receiver gain.
6. The audio frequency output can be used locally at the receiver for telephone or monitor loudspeaker reception, or can be fed to remote positions for loudspeaker or telephone reception via 600 ohm lines.
7. The receiver may be operated from a 230 volt or 115 volt, 40 to 60 cycle a.c. supply.
8. A brief description of the units comprising the receiver, and the function and operation of the controls, is given below.

RF UNIT

9. (a) The input circuits to this receiver are designed to function with either high or low impedance aerials, excepting B4OC and B4OD, which have the low impedance input only. It contains the first three stages of the receiver; two RF stages and the mixer stage.

The first RF stage is a conventional RF amplifier, with an Anti-Cross-Modulation control in the grid circuit.

The second RF stage is also a conventional RF amplifier, with a.g.c. applied.

The frequency changer stage employs a mixer valve, with a separate local oscillator valve.

- (b) The receiver covers a frequency range of 640 kc/s to 30 Mc/s, in five bands as follows:-

Band	Frequency Range
1	640 kc/s to 1.65 Mc/s
2	1.57 Mc/s to 4.1 Mc/s
3	3.9 Mc/s to 10 Mc/s
4	9.5 Mc/s to 18.5 Mc/s
5	17.6 Mc/s to 30.5 Mc/s

IF UNIT

10. (a) There are three stages of amplification at an intermediate frequency of 500 kc/s. The third stage incorporates the detecting, a.g.c. and noise limiter diodes. To receive c.w. signals and to calibrate the receiver, the b.f.o. output is also mixed with the IF signal in this stage, and the resultant audio signal passed to the first audio amplifier in the following unit. A.G.C. voltage may be applied to the first two stages.

- (b) Different degrees of IF selectivity are available. These and associated circuits are as follows:-

B40A

- (i) Two positions of selectivity "Wide" - 8 kc/s, "Narrow" - 3 kc/s (the third position of the switch concerned is a 200 c/s audio note filter in the AF and Power Unit).

- (ii) A.G.C. voltage automatically applied for all conditions of working excepting MANUAL.

B40B/C/D

Three positions of selectivity 8 kc/s, 3 kc/s and 1 kc/s. The last position is a 1 kc/s crystal band-pass filter in the second IF grid circuit.

A.G.C. is controlled by an On/Off switch, for all conditions of working.

- (c) The operating conditions controlled by the SYSTEM switch are as follows:-

Receivers B40/A	6 position SYSTEM switch
Receivers B40B/C	5 position SYSTEM switch
Receiver B40D	7 position SYSTEM switch.

(i) Receiver B40/A/B/C - SYSTEM SWITCH -

System	Condition	Patterns 57140/A		Patterns 57140B/C	
		Sw. Pos.	A.G.C.	Sw. Pos.	A.G.C.
Manual	b.f.o. at IF	1	Off		
Low	b.f.o. at IF - 1 kc/s	2	On	1	On or Off
High	b.f.o. at IF + 1 kc/s	3	On	2	"
Tune	b.f.o. at IF (for initial tuning)	4	On	3	"
R/T(Voice)	b.f.o. off	5	On	4	"
Cal:	b.f.o. crystal controlled at IF	6	On	5	"

(ii) Receiver B40D - SYSTEM SWITCH -

System	Condition	Switch Position
FSK Wide - Low	b.f.o. at IF - 2.55 kc/s	1)
FSK Wide - High	b.f.o. at IF + 2.55 kc/s	2)
FSK Narrow - Low	b.f.o. at IF - 1 kc/s	3)
FSK Narrow - High	b.f.o. at IF + 1 kc/s	4)
Tune	b.f.o. at IF (for initial tuning)	5)
R/T (Voice)	b.f.o. Off	6
Cal.	b.f.o. crystal controlled at IF	7

b.f.o. switched On

The a.g.c. can be switched On or Off at any position of the switch

(d) As indicated above, the beat frequency oscillator is included in this unit. For calibration, the 500 kc/s crystal controlled position is used to give suitable check points on the scales. The monitor loud-speaker and 600 ohm main output socket are also mounted on this unit.

AF AND POWER UNIT

11. (a) The audio amplifier consists of a pre-amplifier and the output stage. The coupling between these two stages is normally resistance capacity, but in B40/A, position three of the Bandwidth switch replaces this coupling with the note filter, tuned to 1000 c/s.
- (b) There are three audio outputs.
- | | |
|--|---|
| (i) Monitor Loudspeaker and Headphones | } All these outputs are
nominally at 600 ohms. |
| (ii) External loudspeaker | |
| (iii) Ship's Control System | |
- (c) The Power Unit consists of h.t. supply circuits employing a double diode rectifier valve connected to the mains transformer to give full wave rectification. In the B40D, two replacement double diodes are used with the anodes strapped, in the same type of circuit. A stabilised h.t. supply is provided to the local oscillator. Supplies for the valve heaters and pilot lamps are also derived from the unit.

RECEIVER 62B - A.P.67757

12. (a) The Receiver 62B is similar to the B40B, but has facilities to make it suitable for use with Sound Reproduction Equipment. Bands 1 and 2 cover different frequencies to those of the B40 and the audio frequency circuits are modified to provide a suitable output level with adequate AF response. The output transformer TR301 is different, the S.R.E. output being obtained from Pins F and B of the output plug PL203. The circuit diagram (Fig. 65, Part 3) and associated components list is at the end of this handbook.
- (b) The frequency bands are as follows:-

Band 1	150 kc/s - 300 kc/s
Band 2	560 kc/s - 1.5 Mc/s
Band 3	3.9 Mc/s - 10 Mc/s
Band 4	9.5 Mc/s - 18.5 Mc/s
Band 5	17.6 Mc/s - 30.6 Mc/s

RECEIVER 62B - A.P.67757A

13. This is the re-valved version of the 62B Receiver. Certain component changes have been made *vis-à-vis* the original pattern receivers to adapt the circuits to changes in characteristics pertaining to the new type valves fitted. The circuit diagram and associated components list appear in Part 3 (Fig. 66).

CHAPTER 3
=====

DETAILED CIRCUIT DESCRIPTION
=====

LIST OF CONTENTS

	<u>Para.</u>
Circuit References	1
Aerial Circuits	2
First RF Amplifier	3
Second RF Amplifier	4
Frequency Changer and Local Oscillator	5
Three stage IF Amplifier	6
A.G.C. Circuit	7
Noise Limiter	8
Beat Frequency Oscillator	9 - 11
First AF Amplifier	12
Output Circuits	13
Gain Circuits	14
Rectifier and Stabilising Circuits	15
Reception of Frequency Shift Keyed Transmissions (B4OD)	16
RF Filter Unit, Des. 12	17

FIGURES

	<u>Fig.</u>
Simplified variable frequency oscillator circuit	1
Crystal controlled oscillator	2
Noise Limiter)	3
Noise Limiter) principles of operation	4
B.F.O. circuit simplified B4O/A/B/C	5
B.F.O. circuit simplified B4OD	6
Output Lines	7
Gain Circuits	8
Filter Unit Des. 12. A.P.56152 Circuit Diagram	9
Filter Unit Des. 12. A.P.56152 Installation Diagram	10
Receiver B4O. A.P.57140/A Circuit Diagram and Components List	11
Receiver B4O. A.P.57140B/C Circuit Diagram and Components List	12
Receiver B4O. A.P.57140D Circuit Diagram and Components List	13

CHAPTER 3

DETAILED CIRCUIT DESCRIPTION

Circuit References

1. The circuit references quoted in this chapter, refer particularly to the pattern or patterns of the receiver described, as the references are not necessarily the same for the same component in different pattern circuit diagrams; this is especially the case with B4OD. Circuit changes made necessary by the introduction of later type valves in the B4OD are given in Chapter 4.7.

AERIAL CIRCUITS

2.
B4O/A/B Fig. 11

- (a) A transmission line or low impedance aerial source, is connected to the primary of the first RF transformer TR101 through Pins B and C of Plug PL101. This primary has a nominal impedance of 80 ohms. These pins are not earthed, the aerial being connected via a co-axial transmission line (A.P.13831) of 92 ohms characteristic impedance. A high impedance aerial may be connected through Pin D of the same plug, this input feeding directly into the secondary side of TR101, which is the grid circuit of the first RF amplifier (V101), tuned by the ganged variable capacitor C112, and the associated trimmers and padders C109, C110 and C111. The RF transformer, trimmers and padders for particular ranges are contained in the turret. On Ranges 1, 2 and 3, C110 and C111 are omitted. Pin A on PL101 is the earth connection.

B4OC/D Fig. 13

- (b) These patterns are designed for HF receiver common aerial working (c.a.w.), and for this purpose, the low impedance input circuits in the turret are modified by the addition of capacitors on Ranges 1, 2 and 3. This in effect converts the primary of TR101 into a π element to form part of a filter network, when several receivers are to be worked from a common aerial. For information concerning common aerial working, refer to B.R.1615. There is no provision for a high impedance aerial.
- (c) If reference is made to Fig. 12 (B4OB/C circuit diagram); NOTES 1 and 2 indicate which components are fitted to the different pattern receivers.

FIRST RF AMPLIFIER

3.
B4O/A/B/C Figs. 11/12

- (a) The signal passes to the grid of the first RF valve V101 (this is a high slope pentode, 10 mA per volt), through the coupling capacitor C102 from the tuned grid circuit. The anode circuit of this valve

consists of the parasitic stopper R105 and the primary of the second RF inter-coupling transformer TR102. When the SYSTEM switch SW202 is in the "CAL" position, calibration signals are fed into this circuit, through the capacitor C131. In this position h.t. is not applied to V101, so that aerial signals are not received; the remaining two tuned RF circuits give sufficient selectivity and amplification to receive harmonics from the b.f.o., to cover the entire range of the receiver. Pulses from an RIS outfit may be fed into the suppressor grid of V101 through Socket SK102.

- (b) The ANTI-CROSS-MOD control RV102 varies the grid bias on V101. When a large RF signal, other than the tuned signal is present at the grid of V101, the selectivity of the first RF stage may be inadequate to prevent overloading of the valve. De-modulation takes place in the first RF valve, and the interfering signal modulates the wanted one. By varying the bias on V101, the working point on the mutual characteristic of the valve can be chosen so that de-modulation does not occur, or is minimised.

B4OD Fig. 13

- (c) The circuit is similar to that of the other patterns. The replacement valve type CV4014, has been incorporated into the circuit without any component values requiring modification. An additional resistor R130 is included to limit the bias voltage developed in the cathode circuit of V101, and a crystal rectifier (MR1) is connected between the slider of the ANTI-CROSS-MOD control (RV101), and the low potential end of R130, to ensure that the grid of V101 is never driven positive by large input voltages, resulting in a flow of grid current. The effect of this grid current would be to reduce the input resistance of the valve and heavily damp the associated tuned circuit, thus reducing selectivity and increasing cross-modulation. The additional circuit MR1 and R130, prevents this condition.

SECOND RF AMPLIFIER

4.
B4O/A/B/C Figs. 11/12

- (a) Valve V102 is a variable μ pentode with a mutual conductance of 2 mA per volt. Its grid circuit is tuned, and comprises the secondary of transformer TR102, a section of the ganged capacitor C116 and three capacitors C113, C114 and C115. The coupling between the primary and secondary of transformer TR102 is adjusted at manufacture. The anode load consists of resistors R113 and R114 in parallel, these resistors are of equal value and are connected in this manner to provide the required dissipation without increasing the size of the components. The signal is parallel fed to the frequency changer grid circuit via capacitor C121 and the primary winding of the transformer TR103.
- (b) Stage gain is controlled manually (RV305), or by the a.g.c. voltage. In B4O/A, position 1 of the SYSTEM switch is for manual control, other positions of this switch giving automatic control. In Receivers B4OB/C the a.g.c. ON/OFF switch SW206 determines the type of control.

- (c) For manual control, bias is fed to the cathode resistor R115 from the manual GAIN control RV305, which is in the cathode return of V102 and the other valves that are otherwise controlled by the a.g.c. voltage. The a.g.c. voltage is fed to the grid through the resistor R112.

B4OD Fig. 13

- (d) Excepting minor changes made necessary by the change of valve, which in this case is type CV454, the electrical characteristics of the circuit in this pattern are the same as those in the other patterns. The values of certain components (see Chapter 4.7) have been modified so that the correct valve potentials, a.g.c. characteristic and stage gain of the valve are maintained.

FREQUENCY CHANGER AND LOCAL OSCILLATOR

5.
B4O/A/B/C Figs. 11/12

- (a) Signals from the previous stage are fed via TR103 to the tuned grid circuit of the frequency changer, consisting of the secondary of the transformer, a section of the ganged capacitor C125, and the three capacitors C122, C123 and C124. The valve V103 is a triode-heptode, only the heptode portion of which is in use. The local oscillator signal is fed into the injector grid (Pin 4). The anode circuit includes the tuned primary of the first IF transformer TR104; this together with the tapped secondary is mounted in the RF Unit giving low impedance coupling to the IF Unit. The coil L201, which is tuned, becomes the input coil in the IF Unit.

- (b) The local oscillator functions either:-

As a normal variable oscillator, tracking with the incoming radio frequency signal to produce the intermediate frequency signal; or crystal controlled to provide stable reception on fixed frequencies.

Details are as follows:-

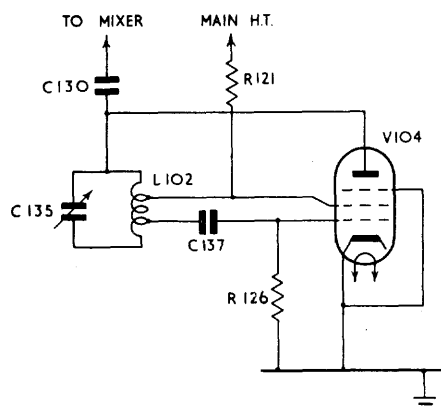

SIMPLIFIED VARIABLE FREQUENCY
OSCILLATOR CIRCUIT
FIG. 1

(i) Variable Frequency Oscillator
Crystal Switch OFF

This is a conventional Hartley circuit; with both sides of the section of the ganged capacitor C135 (C126, B4OD) insulated from earth. The output from the frequency changer is taken from the anode through C130 (C184, B4OD). When the CRYSTAL switch is set to OFF, the crystal terminals are short-circuited to minimise the effect of the crystal on the local oscillator.

(ii) Crystal Controlled Oscillator

Crystal Switch ON

When switched to this method of operation, the circuit becomes a Colpitts crystal oscillator, coupled electronically to the anode circuit; which is tuned to the required harmonic of the crystal. A table showing how these frequencies are determined is given below. The function of L101 (L106, B40D) is to provide a high impedance RF path from the cathode to earth.

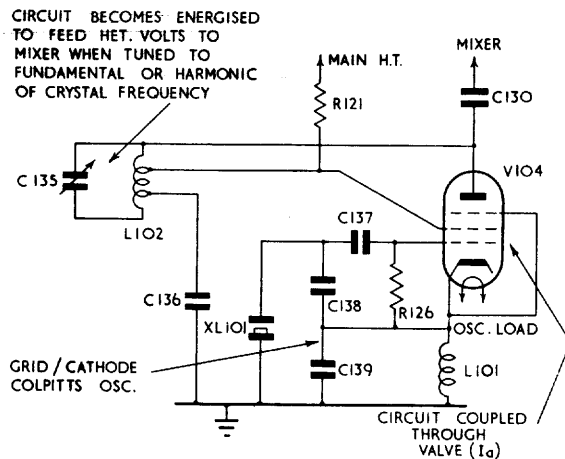

CRYSTAL CONTROLLED OSCILLATOR FIG. 2

Note. The four tuned circuits in the RF Unit have the associated components with the exception of the ganged capacitors, located in the turret switch compartments for the individual wavebands.

Band	Signal Frequency (S) kc/s	Derivation of Crystal Freq. kc/s	Range of Crystal Frequencies
1	640 - 1650	S + 500	1140 - 2150
2	1570 - 4100	S + 500	2070 - 4600
3	3900 - 7000	S + 500	4400 - 7500
	7000 - 10 000	$\frac{S + 500}{2}$	3750 - 5250
4	9500 - 14 500	$\frac{S + 500}{2}$	5000 - 7500
	14 500 - 18 500	$\frac{S + 500}{3}$	5000 - 6333
5	17 600 - 22 000	$\frac{S + 500}{3}$	6033 - 7500
	22 000 - 30 600	$\frac{S + 500}{4}$	5625 - 7775

B4OD Fig. 13(c) (i) Frequency Changer Stage

This stage is similar to the other patterns. The new valve CV2128 made certain minor changes in component value necessary, to maintain the correct working levels of the valve.

(ii) Local Oscillator Circuit

A modification has been made in the local oscillator circuit to facilitate f.s.k. reception, consisting of a small variable capacitor C159, added across part of the coil L101, to give fine tuning. The capacitor is driven by a slow motion drive from a control on the front panel marked OSC TRIM (See Fig. 3, Chapter 1). A scale having ten divisions marked 5 - 0 - 5 is viewed through a window in the panel. The range of the fine tuning is approximately ± 5 kc/s at 20 Mc/s, and there is a proportional decrease in this range as the frequency is reduced. The function of this control is explained in para. 16, which deals with requirements for f.s.k. reception, and the means whereby they are provided in this pattern of the receiver. The local oscillator valve is now type CV4014.

THREE STAGE IF AMPLIFIER6.
B4OA/B/C Figs. 11/12

- (a) This amplifier follows conventional lines employing variable μ pentode valves V201, V202 and V203. The centre frequency is 500 kc/s. The BANDWIDTH switch SW201 changes the coupling between the primary and secondary windings of each of the transformers TR201, TR202 and also TR104 (TR116 B4OD) in the RF Unit. In position 1 (WIDE) the windings are over-coupled, giving bandwidth of approximately 8 kc/s. In B4O/A receivers, positions 2 and 3 (NARROW & NOTE-FILTER) the coupling is loose, giving a bandwidth of approximately 3 kc/s.
- (b) In Receivers B4OB/C the second position of the BANDWIDTH switch is the same, but the third i.e. position switches a double crystal gating circuit into operation instead of the audio note filter. By reference to the circuit diagram Fig. 12, it will be seen that this circuit is incorporated in the grid circuit of valve V202. It consists of a 1 kc/s pass-band filter, switching in on the third position of the BANDWIDTH switch.
- (c) A.G.C. voltage can be applied to valves V201 and V202, by means of the SYSTEM switch in Receivers B4O/A and the A.G.C. ON/OFF switch in B4OB/C/D (see Fig. 8). When switched to manual operation the a.g.c. line is earthed and the gain setting determined by the setting of the manual RF GAIN control RV305.
- (d) An output for the IF method of working Outfit REC is taken from the cathode resistors R235/210 of the third IF valve V203, to the co-axial socket SK202.

B4OD Fig. 13

- (e) The replacement valves in the IF Unit are all Type CV131. The value of the valve cathode resistors in the first two stages has been reduced to ensure the correct biasing of the valves.

A.G.C. CIRCUIT

7. (a) A.G.C. rectification is carried out by half of the double diode valve (V204a), fed from the primary side of the last IF transformer TR203. The cathode of this valve is biased from the potential divider R212 and R213 to give the requisite delay voltage. The load comprises two resistors R214 and R215 (R236/7 in B4OB/C/D); the full a.g.c. voltage being applied to the RF and IF stages concerned. The tapping from the load applies part of the available voltage to the grid of the first audio frequency amplifier V301.

B4O/A Fig. 11

- (b) For c.w. operation, resistor R217 and capacitor C219 are short-circuited by the SYSTEM switch SW202b/c, positions 2, 3 and 4. This reduces the resistance and increases the capacity of the line, to shorten the voltage build-up and retard the decay time. As soon as the c.w. transmission commences a.g.c. voltage is applied, and retained during the telegraphic spaces in the carrier. In switch position 5, R217 and C219 are in circuit to make equal the a.g.c. voltage build-up and decay time, for effective voice working, when the carrier is constant during transmission.

B4OB/C Fig. 12

- (c) The a.g.c. time constant circuits are modified to give an 0.1 second charge and 1 second discharge for all systems of operation. R217 and C219 are deleted from these patterns.

B4OD Fig. 13

- (d) The circuit is not changed fundamentally from the B4OB/C version, excepting that the values of resistors R212, R213 and R237 are changed to alter the delay voltage and the a.g.c. voltage supplied to the first AF amplifier.

NOISE LIMITER

8.

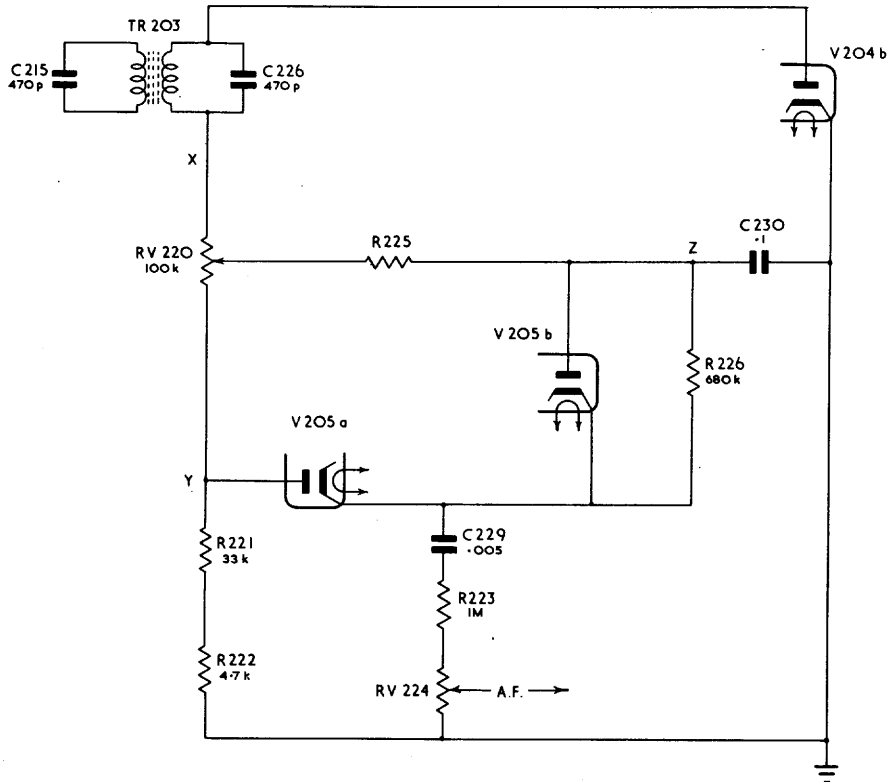

FIG. 3

(a) Under normal signal conditions, an alternating voltage at 500 kc/s with AF modulations superimposed is developed across the secondary of TR203 such that, when the anode of the detecting diode (V204b) is positive with respect to the cathode, the diode will conduct. RF filters remove the carrier frequency, leaving only the rectified modulation. Current will flow through the circuit RV220, R221 and R222; the point 'X' becoming negative with respect to point 'Y'.

(b) C230 will charge through R225 and due to the long time constant of this circuit, the point 'Z' will take up a mean d.c. level with respect to earth (Fig. 3).

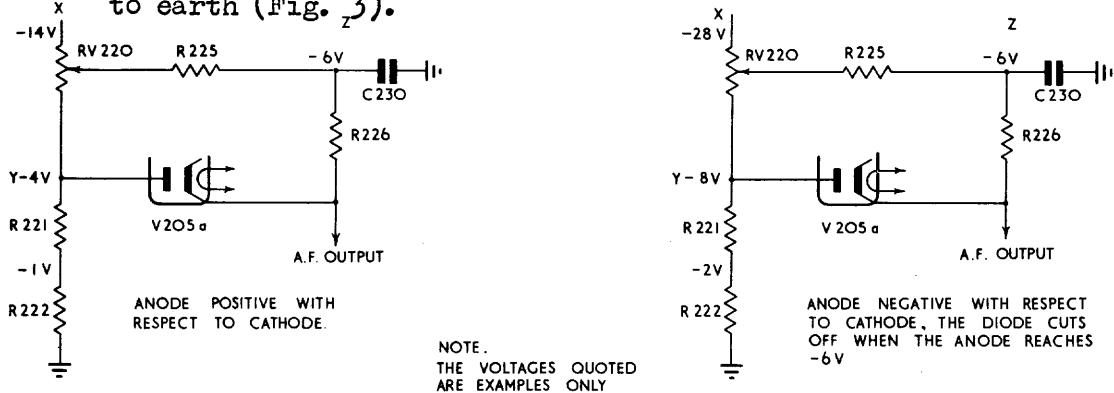

FIG. 4

(c) Since the anode of V205a is connected to point 'Y', whilst its cathode is connected via R225 and R226 to a point of relatively negative potential on RV220, the diode will conduct. It will thus present a low impedance to the AF modulation, which will be coupled by C229 to the AF GAIN control.

- (d) Meanwhile the cathode of V205b is connected virtually to point 'Y' (due to the low impedance presented by V205a), whilst its anode is connected via R225 to a point of relatively low potential on RV220. The valve is therefore, non-conducting.
- (e) For the proper understanding of the noise limiting action of the circuit, it should be realised that the potential at point 'Y' varies with the AF modulation. Point 'Z', however, remains at a fairly steady d.c. potential, due to the long time constant of R225 and C230.
- (f) A pulse of interference will have the effect therefore, that instantaneously, the potential at 'Z' will not change but the potentials along the chain RV220, R221 and R222 will increase their negative value as shown in Fig. 4.
- (g) When the voltage at 'Y' falls below the voltage at 'Z', V205a will cease to conduct.
- (h) Thus the voltage at V205a cathode, passed to the audio circuits is normally not limited, but sharp peaks of interference will be clipped off.
- (j) If, due to the self-capacity of V205a, some of the interfering pulse passes through the valve after it has become non-conducting, it is shunted to earth via C230 and V205b, whose cathode is now negative with respect to its anode and is therefore conducting.
- (k) It will be seen that RV220 can vary the potential between 'Y' and 'Z', and consequently the depth of modulation that can be passed without clipping. In this case it is a maximum of 80% with the slider of RV220 at the top, and 10% at the bottom where the points 'X', 'Y' and 'Z' are at the same potential.

BEAT FREQUENCY OSCILLATOR

9. B40/A/B/C Fig. 5.

- (a) The circuit functions as a Hartley oscillator in the c.w. positions of the SYSTEM switch SW202, is inoperative in the R/T position, and is crystal controlled in the CAL position. In receivers B40/A, the oscillator does not function in the WIDE position of the BANDWIDTH switch SW201, as in this position the screen supply to the valve is broken. With the SYSTEM switch in the CAL position, the screen draws its h.t. supply from another source of higher potential, to increase the screen current and make the circuit oscillate, so as to provide the range of harmonics required. This also makes the calibration facility independent of the position of the BANDWIDTH switch. In B40B/C the b.f.o. functions on all positions of the BANDWIDTH switch.

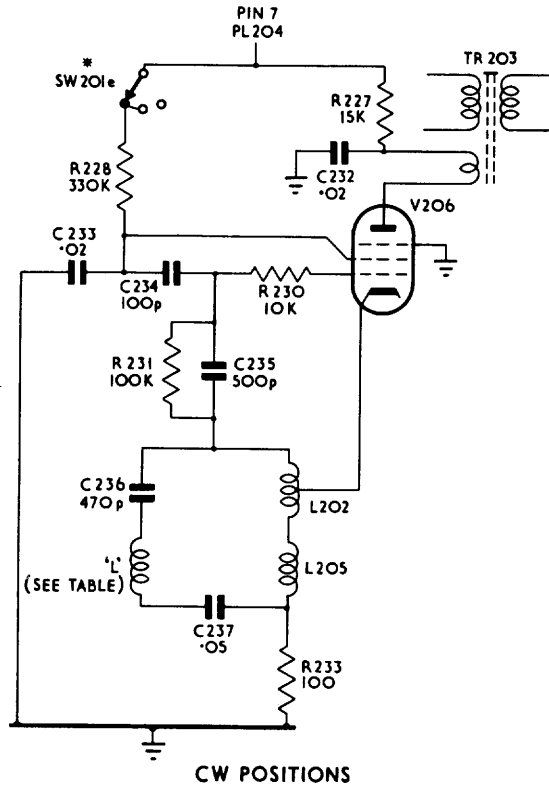

SW 202 POS.	L	SYSTEM	FREQ.
1	L204	MANUAL	500kc/s
2	L203	LOW	499kc/s
3	SHORT CCT.	HIGH	501 kc/s
4	L204	TUNE	500kc/s

* SW201e PATTS. 57140/A.
DIRECT CONNECTION PATTS. 57140B/C.

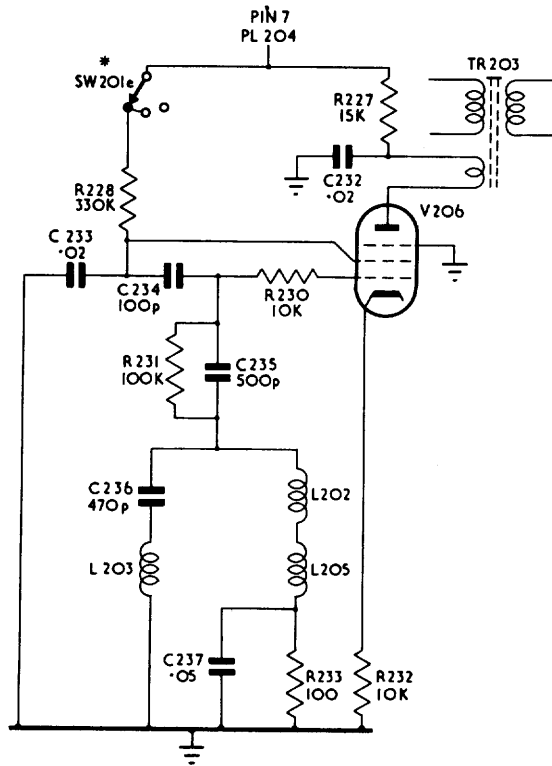

SW 202 POS. 5 PATTS. 57140/A.
POS. 4 PATTS. 57140B/C.
(INOPERATIVE)

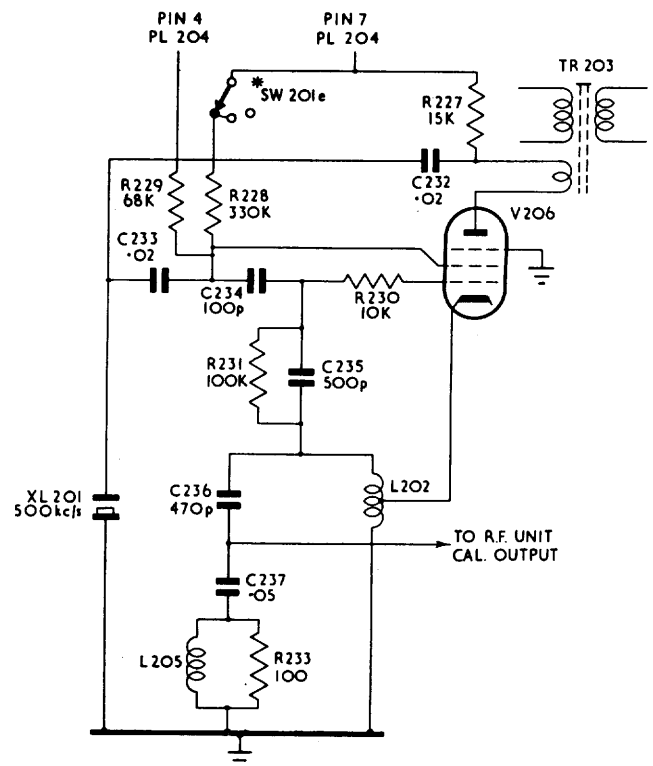

SW 202 POS. 6 PATTS. 57140/A.
POS. 5 PATTS. 57140B/C.
(FREQ. 500kc/s.)

- (b) The main tuned circuit consists of L202 and C236 and resonates 1 kc/s above the IF of 500 kc/s. The operating frequencies of the b.f.o. are depicted in Fig. 5, the SYSTEM switch position varying according to requirement. For those positions where the frequency of the tuned circuit equals the IF, a small inductance L204 is added in series with the main circuit. The larger inductance L203 reduces the resonant frequency still further to 1 kc/s below the IF for the LOW working position of the SYSTEM switch.
- (c) The anode circuit of the b.f.o. oscillator valve V206, is inductively coupled to the secondary winding of the last IF transformer TR203; this is the sole function of the anode of this valve, in the oscillatory circuit the screen operates as the virtual anode. As there is only a small degree of coupling between the IF transformer windings, the b.f.o. injection has negligible effect on the a.g.c. voltage derived from the primary.
- (d) With the SYSTEM switch in the R/T position the b.f.o. valve cathode is connected to chassis through R232 via SW202n. As well as stopping the valve from oscillating this prevents the potential of the cathode from rising too far above that of the chassis, this could happen if the cathode was left unconnected, thereby causing arcing when the switch was moved to another position, with resultant damage to the cathode of the valve.
- (e) In the CAL position the SYSTEM switch removes the short circuit from crystal XL201 and the circuit is crystal controlled. Although under these conditions the tuned circuit has a natural frequency of 501 kc/s, the crystal causes it to oscillate at its own frequency of 500 kc/s. The additional screen voltage to provide the strong oscillation required, is obtained through SW202h to the h.t. line, which comes through Pin 4 of PL204, as well as the normal supply coming from Pin 7. The h.t. supply to the first RF valve is open-circuited to prevent signals from the aerial coming into the receiver during calibration; this also prevents the harmonics being radiated and breaking wireless silence. The calibration signal, consisting of the fundamental 0.5 Mc/s and its associated harmonics is passed from the coupling coil L205, through SW202m-k-j and the second RF transformer TR102, and so through the receiver. Harmonics are available up to the 60th (30 Mc/s), the fundamental being employed to beat with the signal from the IF stages at the second detector.

B4OD Fig. 6

10. (a) The circuit is modified to give two extra b.f.o. pitch positions for FSK WIDE operation, to obtain an audio beat note of 2550 c/s above (HIGH) or below (LOW), the intermediate frequency.
 - (b) This is achieved by an arrangement of pre-set variable capacitors, selected by the SYSTEM switch. The first four positions of the SYSTEM switch give four different b.f.o. pitch frequencies (shown in Fig. 6), the fifth is the TUNE position. A comparison between the diagrams Fig. 5 and Fig. 6 will show that the fundamental operation of the circuit remains unchanged. The NARROW f.s.k. positions give an audio beat frequency (1000 c/s) above and below the IF. This was previously obtained by the pitch coils L203 and L204, which are deleted from this receiver. The NARROW FSK positions also provide a 1000 c/s note for the reception of c.w.
 - (c) The R/T and CAL circuits in this pattern are selected on positions 6 and 7 of the SYSTEM switch.
 - (d) Valve V206 is the new type CV131. No component modifications result from this change.
11. The calibrator crystals for the B4OB/C/D receivers are specially processed, and though similar to the type 'A' crystals fitted to the other patterns, are not interchangeable with them. For identification, crystals for B4OB/C/D are marked "Pattern 67864 Crystal 500 kc/s".

FIRST AF AMPLIFIER

Figs. 11/12/13

12. (a) The valve V301 is a variable mu pentode, with a.g.c. voltage tapped from the a.g.c. load network applied to its grid. The audio signal comes from the main AF GAIN control RV224. B4O/A receivers have the anode circuit of the valve arranged to function with two alternative loads, switched by the BANDWIDTH switch SW201d in the IF Unit, through PL204 and SK301. In the WIDE and NARROW positions of this switch, the anode load is R302, in the NOTE FILTER position, it becomes a tuned circuit consisting of L301 and C302. This circuit resonates at 1000 c/s and only signals of about this frequency develop appreciable voltages across the load, to be passed to the output valve. The pass-band of this circuit is about 200 c/s.
- (b) The above facility is not included in the B4OB/C/D receivers, as the third position of the BANDWIDTH switch brings into circuit the crystal band-pass filter associated with the IF circuits, instead of the note filter. This last mentioned component is deleted from these receivers, so that the anode load of V301 consists only of the load resistor R302.
- (c) In B4OD the valve is replaced by the later type CV.454. Minor changes have been made in component values to maintain the electrical characteristics of the stage.

OUTPUT CIRCUITSOutput Stage Figs. 11/12/13

13. (a) The receiver has a single valve output stage, employing a power pentode valve V302. This delivers a maximum audio frequency power of 2.5 watts to the output lines. The full output power is normally used to feed an external loudspeaker. Operating the DUMMY LOAD switch SW204 to the ON position, connects a 620 ohms resistor across this output and disconnects the loudspeaker line. The output transformer TR301 has a resistor R313 connected across its primary to reduce peak voltage, this prevents flash-over, should the remote loudspeaker become inadvertently disconnected. In B40D the valve is replaced by a new type CV.2136. This has resulted in minor changes in the cathode circuit components.

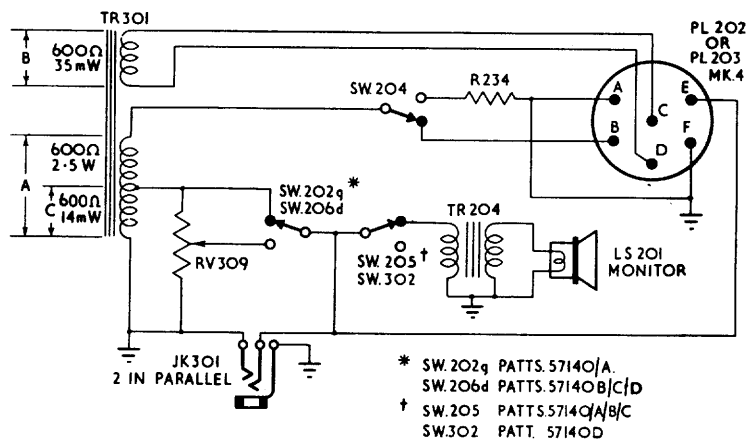
Output Lines

OUTPUT LINES

FIG. 7

- (b) (i) The three audio outputs are fed from the secondaries of transformer TR301, through socket and plug connectors from the AF and Power Unit, to the output plug in the IF Unit. The output plug (PL203, B40/A/B/C, PL202, B40D) is a Mark 4 sealed type and provides a six-way outlet at the rear of the IF Unit. To make the above diagram as clear as possible, the intermediate unit connecting plugs and sockets have been omitted.
- (ii) The three output channels comprise:-
- A- A 2.5W loudspeaker line, incorporating a switch SW204 (DUMMY LOAD). When this switch is placed in the "External L.S. OFF" position, i.e. the switch toggle to the front of the receiver, a compensating resistor R234 is connected to earth across the output.
 - B- An output derived from a separate winding of the transformer, normally employed to provide up to 35 mW into a ship's control system.

-C- The subsidiary headphone and monitor loudspeaker line extension, with a nominal power rating of 14 mW. RV309 gives further audio gain control when the a.g.c. is operative. This control is part of the two gang GAIN control RV305/309. The operation of RV309 is determined by the SYSTEM switch (SW202g) in B40/A receivers and by the a.g.c. switch (SW206d) in the later patterns.

- (iii) All these outputs have a nominal impedance of 600 ohms, so that it is necessary for the external reproducers to be matched to this impedance. The output level for all lines is governed by the setting of the AF GAIN control RV224.

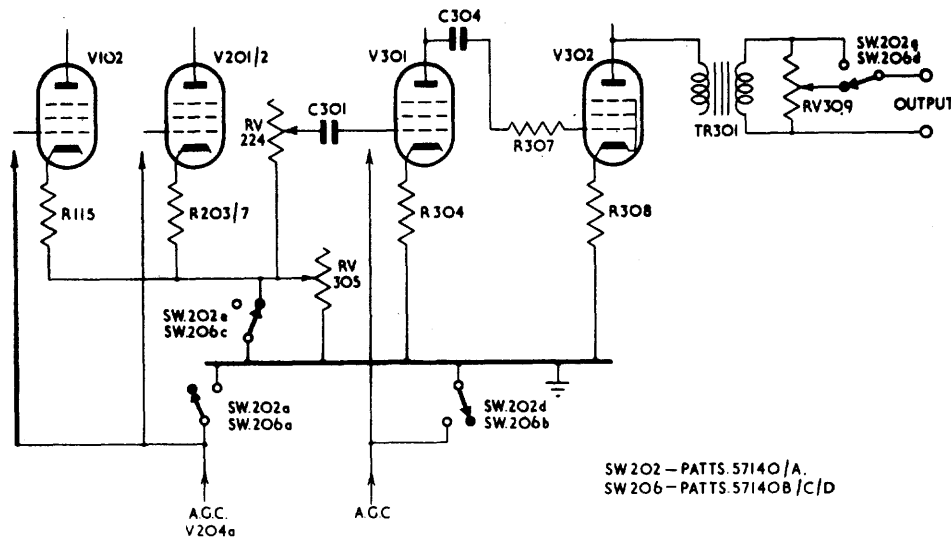

GAIN CIRCUITS
FIG. 8

14. (a) The receiver can be operated with a.g.c. ON or OFF depending upon the setting of the control switches. "Manual" control of AF gain is provided at all times, but RF gain is manually or automatically controlled. The means by which the a.g.c. is switched, differs between the B40/A receivers and the later patterns. On the former, a.g.c. is provided on positions 2 to 6 of the SYSTEM switch and is disconnected in position 1, where RF gain is manually controlled. In B40B/C/D receivers, a.g.c. is controlled simply by the a.g.c. ON/OFF switch, manual control being provided in the OFF position.
- (b) Electrically, the circuit is the same in all patterns of the receiver, the switch names representing the only difference. This is shown in Fig. 8 above. In the case of SW202, only positions 1 and 2 are shown, as the remainder of the positions on the SYSTEM switch sections concerned, are connected to position 2.

- (c) In the switching position shown, RF gain is controlled by the a.g.c. voltage. The headphones and monitor loudspeaker output line level is adjusted under these conditions by RV309, which is the a.f. section of the ganged GAIN control, switched by SW202g/206d. The other outputs are omitted from the diagram, as they are not controlled by RV309. The RF/IF section of the GAIN control (RV305) is short-circuited by SW202e/206c and automatic control voltage fed to the grids of the relevant valves.
- (d) When the RF gain is manually controlled, RV309 is disconnected by the opening of SW202g/206d. Switch sections SW202e/206c open and RV305 becomes the operative component of the GAIN control, varying the cathode voltages of the RF and IF valves concerned, to give the desired gain adjustment. The a.g.c. lines to these valves and the first AF valve are short-circuited to earth at SW202a/206a and SW202d/206b respectively.

RECTIFIER AND STABILISING CIRCUITS

15.
B40/A/B/C Figs. 11/12

- (a) The double-diode valve V303, functions as a full wave rectifier. The smoothing circuit comprises two chokes, L302 in the positive h.t. line, and L303 (L304, B40B/C/D) in the negative h.t. return line, with smoothing capacitors C305, C307 (C315, B40B/C/D) and C308 (C314, B40B/C/D).
- (b) V304 is a neon stabiliser for the supply voltage to the local oscillator valve V104. The stabiliser priming electrode is supplied from the main h.t. line through R310. To provide effective de-coupling, the stabiliser valve is earthed at the RF Unit. Resistor R312 reduces the voltage to the first RF valve, which is a separate supply.

B40D Fig. 13

- (c) This receiver incorporates an additional rectifier valve, the two anodes of each valve being strapped together and the whole arrangement used to form a full-wave rectifier circuit, with a valve at each end of the mains transformer h.t. winding. The valves employed are the preferred type CV.493 (V303 and V304). In this pattern the stabilising valve is V305, which is a replacement type CV.1832. As there is no priming electrode in this new valve, R310 is not included in this pattern. With the exception of the modifications mentioned above, the circuits are similar to the other pattern receivers.

RECEPTION OF FREQUENCY SHIFT KEYED TRANSMISSIONS (FSK) B40D only

(Fig. 13)

16. (a) As previously mentioned, this receiver is modified for the reception of frequency shift keyed signals, in two particulars.
- (1) The b.f.o. is changed to operate at two additional frequencies:- FSK WIDE "HIGH" and FSK WIDE "LOW". The previous positions for c.w. operation are also used for f.s.k. reception on NARROW "HIGH" and NARROW "LOW".

- (2) A fine tuning control has been supplied to give vernier adjustment of the local oscillator frequency.
- (b) In the frequency shift system the MARK (inactive) signal is transmitted on one radio frequency and the SPACE (active) signal on a different radio frequency. The difference in frequency (amount of shift), has been fixed at 850 c/s as the standard for HF frequencies at the present time. Therefore for a nominal transmitting frequency of 5 Mc/s, the MARK signal is radiated on 5 Mc/s + 425 c/s and the SPACE signal on 5 Mc/s - 425 c/s. MARK signals are always radiated on the higher frequency,
- (c) The audio frequency discriminator of the Frequency Shift Converter CV89A/URA-8A in the WIDE condition, works over the range of frequencies 2025 to 3075 c/s, i.e. the centre frequency is at 2550 c/s and the excursion is ± 525 c/s. In the NARROW shift condition, the centre frequency of the discriminator is 1000 c/s and the excursion is approximately ± 100 c/s.
- (d) The Receiver B40C and earlier models, have pre-set frequencies for the beat frequency oscillator marked 'C.W. "LOW", TUNE and C.W. "HIGH" corresponding to 499 kc/s, 500 kc/s and 501 kc/s respectively, and unless additional b.f.o. frequencies are made available at 502.55 kc/s and 497.45 kc/s, it is only possible to obtain the correct audio frequency for the discriminator (2550 c/s) by mistuning the receiver so that the frequency passed to the intermediate frequency amplifier is 498.45 kc/s or 501.55 kc/s. The IF amplifier is tuned to 500 kc/s, so that under such conditions the receiver is not working at its maximum efficiency, for if the IF bandwidth is not switched to 1 kc/s, which is all that is required for the transmission of the message, the full gain of the IF amplifier will not be realised. If a wider bandwidth is used, the performance will be impaired by the increase of noise.
- (e) With a centre discriminator frequency of 2550 c/s, the frequencies of the MARK and SPACE signals are 2125 and 2975 c/s, and as the range of the discriminator is only 2025 and 3075 c/s, the margin for mistuning is very small. Without the fine tuning control OSC. TRIM the movement of the main RF control is too coarse for satisfactory operation on the higher frequencies, (9.5 - 30.5 Mc/s). Details concerning the modifications are given under the relevant headings in this chapter, and in Chapter 4.

R.F. FILTER UNIT DESIGN 12

17. (a) Additional protection against Radar transmissions, particularly Types 79, 279, 281, 960 and variants, is provided by fitting the Filter Unit Design 12, (A.P.56152) in series with the aerial lead to the set, external to the receiver.

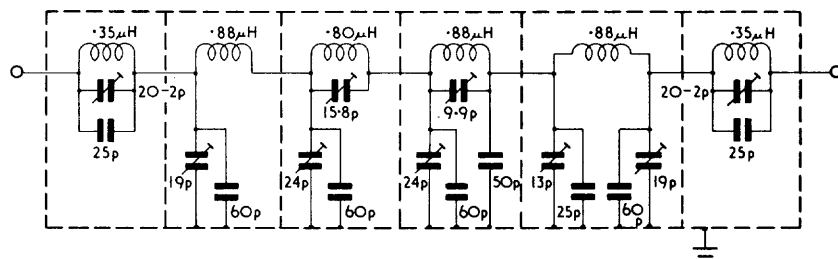

FILTER UNIT DES.12 A.P.56152. CIRCUIT DIAGRAM.
FIG. 9

- (b) This is a low pass RF Filter and provides protection against transmissions on frequencies above 30 Mc/s.
- (c) When the source of the interference is inoperative and where maximum receiver sensitivity can be usefully employed, the filter can be taken out of circuit, at the aerial exchange, by means of a "through connector" arrangement.

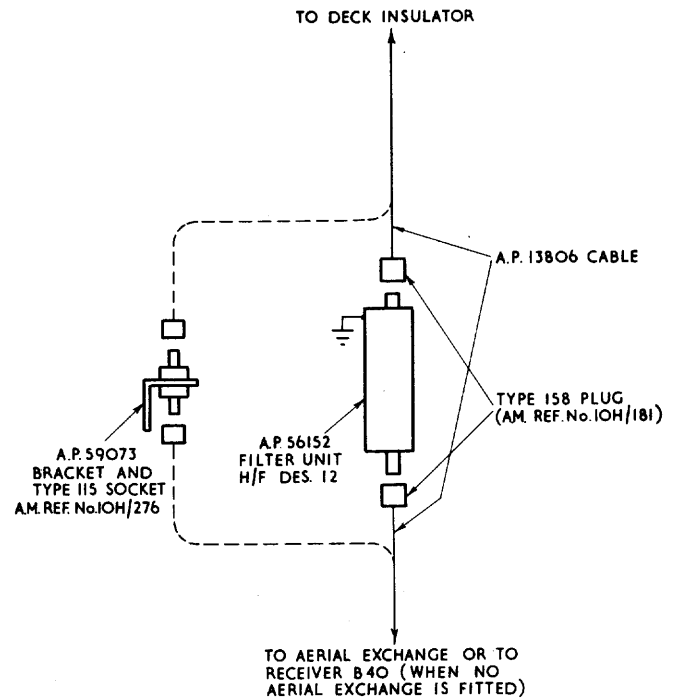

FILTER UNIT DES.12 AP.56152. INSTALLATION DIAGRAM.
FIG. 10

FIG. 11

R	101	103	104	105	106	108	109	110	111	112	113	114	116	117	118	120	R				
C	101	103	105	107	108	113	118	114	115	117	116	119	120	121	122	126	124	127	128	129	C
MISC	PL101	TR101	RV102	SW101	V101	TR102	L102	SW102b	XL101	SW102c	V103	V104	TR104	SK101	PL103	MISC					
	SW102a	LP101-107	RV125	SK102																	

R.F. UNIT

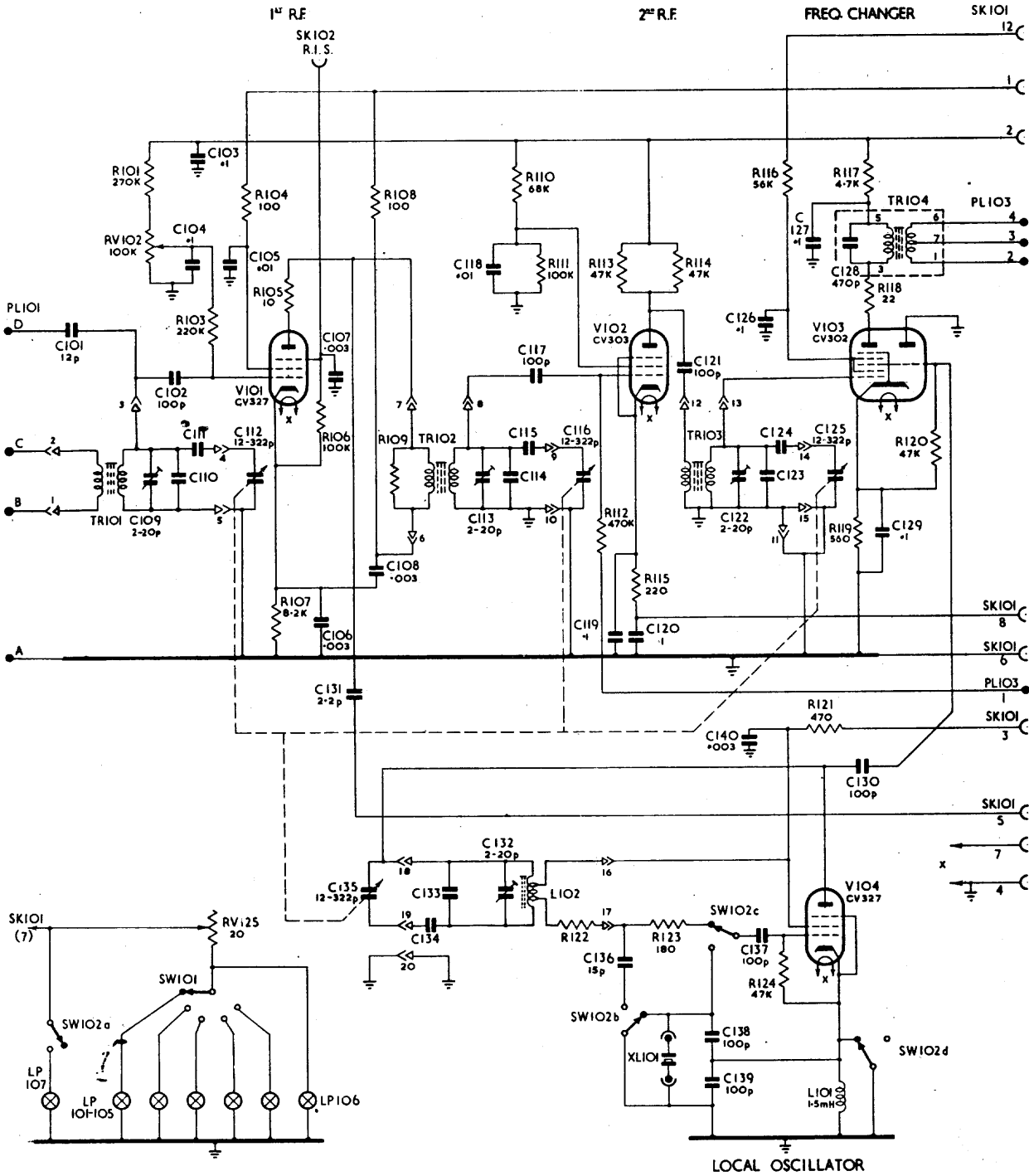

NOTE:- REFER TO FIG. 2 PT. 3 FOR VALUES OF COMPONENTS IN TURRET COMPARTMENTS.

FIG. 11

214.211.	221.	225.	312.	311.	303.	313.		R
31.215.	229.	222.219.	301.310.304.	302.	306.307.308.			
333.228.230.232.		223.226.						
	214.	226.	306.	305.	307.	308.	311.	309.310
	215.	227.	301.302.	303.	304.	313.	312.	
	235.	224.	225.	231.				
	TR.203.V.206. RV.220.	V.204b.	RV.224.	SW.202h.	PL.204.	SK.301.	V.304.	L.302
	2.L.205.	SW.202h.	SW.202f.	SW.202e.	SW.202d.	SW.201d.	RV.305.L.301.	V.301
								L.303
							V.302	RV.309
								JK.301,302.
								FS.301.TR.302.
								SK.302.
								SW.301.PL.301.
								FS.302.
								FS.303
								MISC.

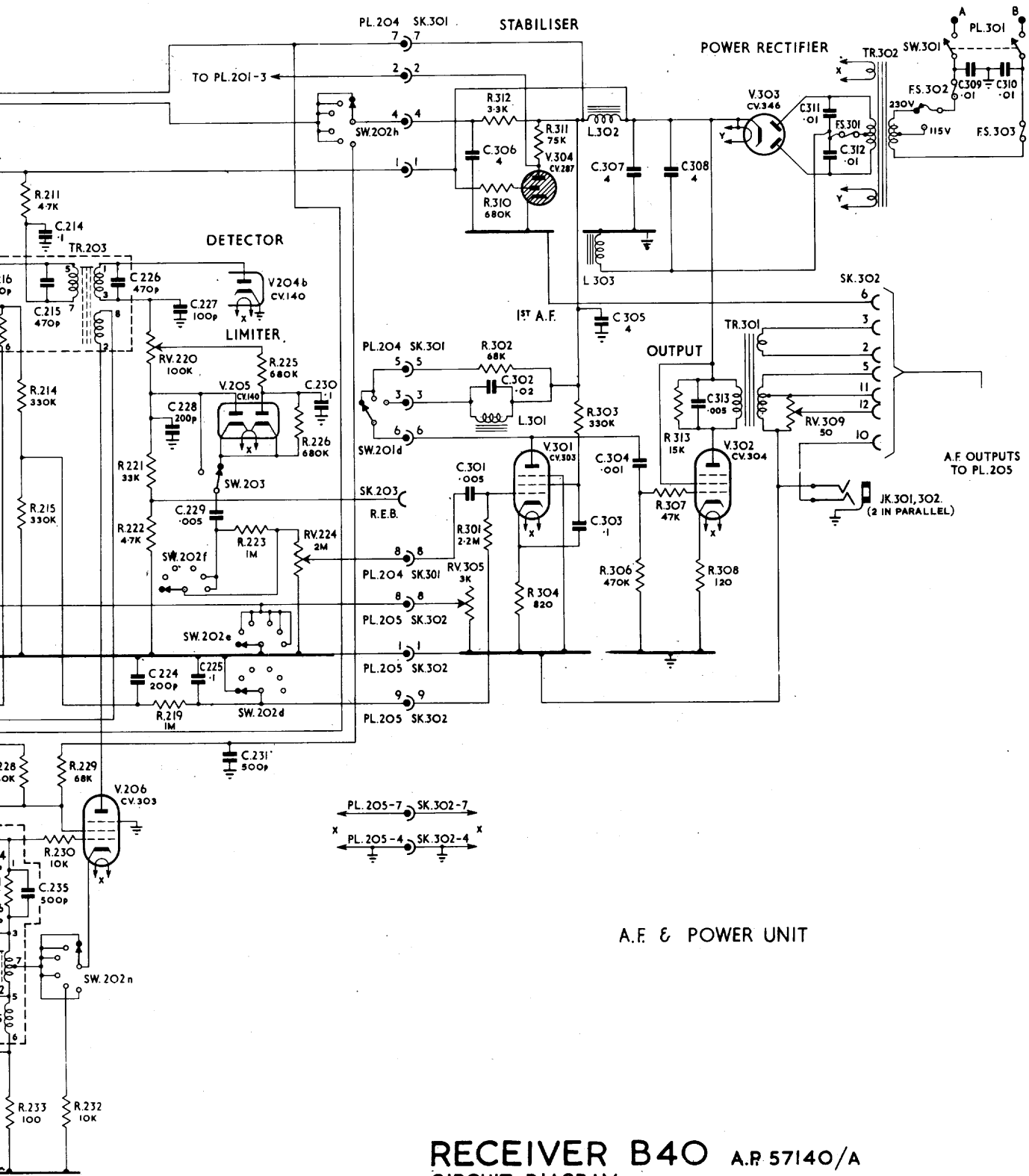

RECEIVER B40 A.R. 57140/A
CIRCUIT DIAGRAM

R	202, 201, 218, 203, 234.	204.	206, 205, 207.	208.	209, 235, 210, 227, 217.	212, 213.	216, 214, 211, 231, 215, 229, 233, 228, 230, 232.
C	201, 223, 238.	202, 203, 205.	206, 222, 221, 219.	207, 208, 210.	211, 212, 213.	217, 218, 219.	214, 215, 235.
MISC	PL. 201, SK. 201, PL. 203, TL.	SW. 201a, SW. 205, SW. 204, SW. 202g, L. S. 201, PL. 205.	TR. 201, TR. 204, SW. 202a, L. S. 201, PL. 205.	SW. 201b, V. 202, SW. 202j.	TR. 202, SW. 202b, SW. 202e, SW. 202g, SW. 202k.	SW. 201c, V. 203, SW. 202p, XL. 201, SW. 202m, L. 202L, 205.	V. 204a, SW. 201e, TR. 203, V.

I.F. UNIT

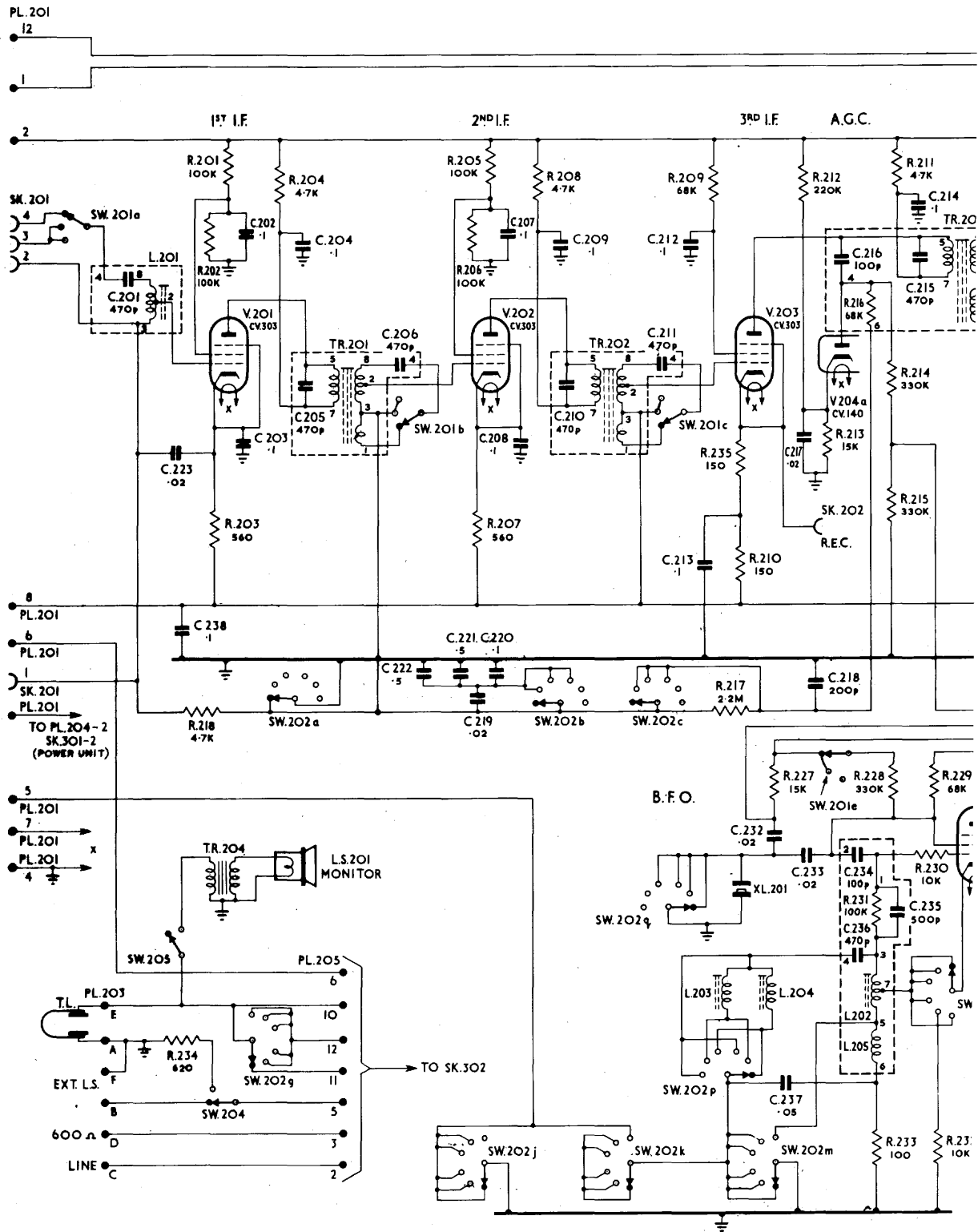

COMPONENTS LIST RECEIVER B40 PATTERNS 57140/A
CAPACITORS

Ref.	A.P. or Joint-Service Cat. No.	Value	Tol.	Rating	Remarks
C101	Z131175	12 pF	10%	500V	
C102	Z123194	100 pF	20%	350V	
C103	Z115095	0.1 μ F	20%	350V	
C104	Z115095	0.1 μ F	20%	350V	
C105	Z124407	0.01 μ F	20%	350V	
C106	Z124477	0.003 μ F	20%	350V	
C107	Z124477	0.003 μ F	20%	350V	
C108	Z124477	0.003 μ F	20%	350V	
C109	*AP. 52437	2-20 pF	10%		Variable
C110	Z131178	15 pF	10%	500V	Band 4
C110	Z131194	47 pF	5%	500V	Band 5
C111	Z125666	600 pF	5%	350V	Band 4
C111	Z125664	450 pF	5%	350V	Band 5
C112	AP. 60189	12-322 pF	$\pm \frac{1}{2}\%$		Ganged Cap Sect.
C113	*AP. 52437	2-20 pF	10%		Variable
C114	Z131169	6.8 pF	10%	500V	Band 2
C114	Z131058	10 pF	10%	500V	Band 3
C114	Z131186	27 pF	10%	500V	Band 4
C114	Z131197	56 pF	5%	500V	Band 5
C115	Z125666	600 pF	5%	350V	Band 4
C115	Z125664	450 pF	5%	350V	Band 5
C116	AP. 60189	12-322 pF			Ganged Cap Sect.
C117	Z123194	100 pF	20%	350V	
C118	Z124407	0.01 μ F	20%	350V	
C119	Z115095	0.1 μ F	20%	350V	
C120	Z115095	0.1 μ F	20%	350V	
C121	Z123194	100 pF	20%	350V	
C122	*AP. 52437	2-20 pF	10%		Variable
C123	Z131169	6.8 pF	10%	500V	Band 2
C123	Z121058	10 pF	10%	500V	Band 3
C123	Z131184	22 pF	10%	500V	Band 4
C123	Z131194	47 pF	10%	500V	Band 5
C124	Z125664	450 pF	5%	350V	Band 5
C124	Z125666	600 pF	5%	350V	Band 4
C125	AP. 60189	12-322 pF			Ganged Cap. Sect.
C126	Z115095	0.1 μ F	20%	350V	
C127	Z115095	0.1 μ F	20%	350V	
C128	Z125665	470 pF	5%	350V	
C129	Z115095	0.1 μ F	20%	350V	
C130	Z131206	100 pF	10%	500V	

* Replacement component to be Z160009.

Ref.	A.P. or Joint- Service Cat. No.	Value	Tol.	Rating	Remarks
C131	Z131165	2.2 pF	0.5 pF	500V	Variable Band 1 Band 2 Band 3 Band 4 Band 5 Band 1 Band 2 Band 3 Band 4 Band 5 Ganged Cap Section
C132	[#] 52437	2-20 pF	10%	500V	
C133	Z131186	27 pF	10%	500V	
C133	Z131181	18 pF	10%	500V	
C133	Z131181	18 pF	10%	500V	
C133	Z131188	33 pF	5%	500V	
C133	Z131197	56 pF	5%	500V	
C134	Z125476	470 pF	5%	350V	
C134	Z126350	1050 pF	5%	350V	
C134	Z126351	2200 pF	10%	350V	
C134	W6424	500 pF	5%	350V	Band 4 Band 5 Ganged Cap Section
C134	Z125450	390 pF	5%	350V	
C135	60189	12-322 pF			
C136	Z131178	15 pF	10%	500V	
C137	Z131206	100 pF	10%	350V	
C138	Z123194	100 pF	20%	350V	
C139	Z123194	100 pF	20%	350V	
C140	Z124477	0.003 μ F	20%	350V	
C201	Z125665	470 pF	5%	350V	
C202	Z115095	0.1 μ F	20%	350V	
C203	Z115095	0.1 μ F	20%	350V	350V
C204	Z115095	0.1 μ F	20%	350V	
C205	Z125665	470 pF	5%	350V	
C206	Z125665	470 pF	5%	350V	
C207	Z115095	0.1 μ F	20%	350V	
C208	Z115095	0.1 μ F	20%	350V	
C209	Z115095	0.1 μ F	20%	350V	
C210	Z125665	470 pF	5%	350V	
C211	Z125665	470 pF	5%	350V	
C212	Z115095	0.1 μ F	20%	350V	
C213	Z115095	0.1 μ F	20%	350V	350V
C214	Z115095	0.1 μ F	20%	350V	
C215	Z125665	470 pF	5%	350V	
C216	Z123194	100 pF	20%	350V	750V 350V 750V 350V
C217	Z115504	0.02 μ F	20%	750V	
C218	Z123274	200 pF	20%	350V	
C219	Z115504	0.02 μ F	20%	750V	
C220	Z115095	0.1 μ F	20%	350V	

[#]Replacement component to be Z160009

CAPACITORS (Cont'd)

Ref.	A.P. or Joint- Service Cat. No.	Value	Tol.	Rating	Remarks
C221	Z115095	0.1 μ F	20%	350V	
C222	Z11514.8	0.5 μ F	20%	350V	
C223	Z115504	0.02 μ F	20%	750V	
C224	Z123274	200 pF	20%	350V	
C225	Z115095	0.1 μ F	20%	350V	
C226	Z125665	470 pF	5%	350V	
C227	Z123194	100 pF	20%	350V	
C228	Z123274	200 pF	20%	350V	
C229	Z115502	0.005 μ F	20%	1000V	
C230	Z115095	0.1 μ F	20%	350V	
C231	Z123456	500 pF	20%	350V	
C232	Z115504	0.02 μ F	20%	750V	
C233	Z115504	0.02 μ F	20%	750V	
C234	Z123194	100 pF	20%	350V	
C235	Z123456	500 pF	20%	350V	
C236	Z125665	470 pF	5%	350V	
C237	Z115505	0.05 μ F	20%	500V	
C238	Z115095	0.1 μ F	20%	350V	
C301	52162	0.005 μ F	20%	1000V	
C302	Z115516	0.02 μ F	10%	750V	
C303	Z115506	0.1 μ F	20%	350V	
C304	Z115500	0.001 μ F	20%	1000V	
C305	Z112521	4 μ F	20%	400V	
C306	Z112521	4 μ F	20%	400V	
C307	Z112521	4 μ F	20%	400V	
C308	Z112521	4 μ F	20%	400V	
C309	Z124409	0.01 μ F	20%	750V	
C310	Z124409	0.01 μ F	20%	750V	
C311	Z124409	0.01 μ F	20%	750V	
C312	Z124409	0.01 μ F	20%	750V	
C313	Z115502	0.005 μ F	20%	1000V	

RESISTORS

Ref.	A.P. or Joint- Service Cat. No.	Value	Tol.	Rating	Remarks
R101	Z223092	270k ohms	10%	$\frac{1}{2}$ W	Variable
RV102	AP. 60525A	100k ohms	10%	$\frac{1}{4}$ W	
R103	or AP. 51464A	100k ohms	20%	$\frac{1}{2}$ W	"
	Z223080	220k ohms	10%	$\frac{1}{2}$ W	

RESISTORS (Cont'd)

Ref.	A.P. or Joint Service Cat. No.	Value	Tol.	Rating	Remarks
R104	Z221110	100 ohms	10%	$\frac{1}{2}W$	
R105	Z221002	10 ohms	10%	$\frac{1}{2}W$	
R106	Z223038	100k ohms	10%	$\frac{1}{2}W$	
R107	Z222123	8.2k ohms	10%	$\frac{1}{2}W$	
R108	Z221110	100 ohms	10%	$\frac{1}{2}W$	
R109	Z222026	1.5k ohms	10%	$\frac{1}{2}W$	Band 1
R109	Z222005	1k ohm	10%	$\frac{1}{2}W$	Band 2
R109	Z222038	1.8k ohms	10%	$\frac{1}{2}W$	Band 3
R109	Z222080	3.9k ohms	10%	$\frac{1}{2}W$	Band 4
R110	Z223018	68k ohms	10%	$\frac{1}{2}W$	
R111	Z223038	100k ohms	10%	$\frac{1}{2}W$	
R112	Z223122	470k ohms	10%	$\frac{1}{2}W$	
R113	Z222216	47k ohms	10%	$\frac{1}{2}W$	
R114	Z222216	47k ohms	10%	$\frac{1}{2}W$	
R115	Z221152	220 ohms	10%	$\frac{1}{2}W$	
R116	Z223009	56k ohms	10%	$\frac{1}{2}W$	
R117	Z222089	4.7k ohms	10%	$\frac{1}{2}W$	
R118	Z221026	22 ohms	10%	$\frac{1}{2}W$	
R119	Z221206	560 ohms	10%	$\frac{1}{2}W$	
R120	Z222215	47k ohms	10%	$\frac{1}{2}W$	
R121	Z221194	470 ohms	10%	$\frac{1}{2}W$	
R122	Z222017	1.2k ohms	10%	$\frac{1}{2}W$	Band 1
R122	Z221185	390 ohms	10%	$\frac{1}{2}W$	Band 2
R122	Z221143	180 ohms	10%	$\frac{1}{2}W$	Band 3
R122	Z221068	47 ohms	10%	$\frac{1}{2}W$	Band 4
R123	Z221143	180 ohms	10%	$\frac{1}{2}W$	
R124	Z222215	47k ohms	10%	$\frac{1}{2}W$	
RV125	AP. 60480A	20 ohms	10%	2.5W	Variable
R201	Z223039	100k ohms	10%	$\frac{1}{2}W$	
R202	Z223038	100k ohms	10%	$\frac{1}{2}W$	
R203	Z221206	560 ohms	10%	$\frac{1}{2}W$	
R204	Z222090	4.7k ohms	10%	$\frac{1}{2}W$	
R205	Z223039	100k ohms	10%	$\frac{1}{2}W$	
R206	Z223038	100k ohms	10%	$\frac{1}{2}W$	
R207	Z221206	560 ohms	10%	$\frac{1}{2}W$	
R208	Z222090	4.7k ohms	10%	$\frac{1}{2}W$	
R209	Z223018	68k ohms	10%	$\frac{1}{2}W$	
R210	Z221131	150 ohms	10%	$\frac{1}{2}W$	
R211	Z222090	4.7k ohms	10%	$\frac{1}{2}W$	
R212	Z223081	220k ohms	10%	$\frac{1}{2}W$	

RESISTORS (Cont'd)

Ref.	A.P. or Joint Service Cat. No.	Value	Tol.	Rating	Remarks
R213	Z222152	15k ohms	10%	$\frac{1}{2}W$	
R214	Z223101	330k ohms	10%	$\frac{1}{2}W$	
R215	Z223101	330k ohms	10%	$\frac{1}{2}W$	
R216	Z223017	68k ohms	10%	$\frac{1}{2}W$	
R217	Z223206	2.2 Megohms	10%	$\frac{1}{2}W$	
R218	Z222090	4.7k ohms	10%	$\frac{3}{4}W$	
R219	Z223164	1 Megohm	10%	$\frac{1}{2}W$	
RV220	AP. 5244OA	100k ohms	20%	$\frac{1}{4}W$	Variable
R221	Z222195	33k ohms	10%	$\frac{3}{4}W$	
R222	Z222090	4.7k ohms	10%	$\frac{3}{4}W$	
R223	Z223164	1 Megohm	10%	$\frac{1}{2}W$	
RV224	AP. 60254A	2.2 Megohms	20%	$\frac{1}{4}W$	Variable
R225	Z223143	680k ohms	10%	$\frac{1}{2}W$	
R226	Z223143	680k ohms	10%	$\frac{1}{2}W$	
R227	Z222153	15k ohms	10%	$\frac{3}{4}W$	
R228	Z223102	330k ohms	10%	$\frac{3}{4}W$	
R229	Z223018	68k ohms	10%	$\frac{3}{4}W$	
R230	Z222131	10k ohms	10%	$\frac{1}{2}W$	
R231	Z223038	100k ohms	10%	$\frac{1}{2}W$	
R232	Z222132	10k ohms	10%	$\frac{3}{4}W$	
R233	Z221111	100 ohms	10%	$\frac{3}{4}W$	
R234	Z243173	620 ohms	5%	4.5W	
R235	Z221131	150 ohms	10%	$\frac{1}{2}W$	
R301	Z223207	2.2 Megohms	10%	$\frac{3}{4}W$	
R302	Z223017	68k ohms	10%	$\frac{1}{2}W$	
R303	Z223101	330k ohms	10%	$\frac{1}{2}W$	
R304	Z221227	820 ohms	10%	$\frac{1}{2}W$	
RV305	Z273001	3k ohms	10%		Variable
R306	Z223122	470k ohms	10%	$\frac{1}{2}W$	
R307	Z222215	4.7k ohms	10%	$\frac{1}{2}W$	
R308	Z221123	120 ohms	10%	$\frac{3}{4}W$	
RV309	Z273001	50 ohms	10%		Variable
R310	Z223144	680k ohms	10%	$\frac{3}{4}W$	
R311	Z244085	7.5k ohms	5%	4.5W	
R312	Z222069	3.3k ohms	10%	$\frac{3}{4}W$	
R313	Z244114	15k ohms	10%	6W	

Note: The above list relates to replacement requirements; all fixed composition resistors having a tolerance of 10%. The corresponding resistors in the receivers may have either 10% or 20% tolerances.

CHAPTER 3
LIST OF COMPONENTS

TRANSFORMERS

Ref.	Pattern No.	Description	
TR101 TR102 TR103 TR104 TR201	(Replace TR101 bands 1-5 with {5905-A.P. 184026/7/8/9/30.	Aerial Transformer	
		1st R.F. Transformer	
		2nd R.F. "	
		I.F. Output "	
		1st I.F. "	
TR202			2nd I.F. "
TR203			3rd I.F. "
TR204		65690	Monitor Loudspeaker Transformer
TR301		65689	Output Transformer
TR302		65561B	Mains Transformer

INDUCTORS

Ref.	Pattern No.	Description	
L101 L102 L201 L202 L203		Choke, 1.5 mH Oscillator	
		Coil Tuned Oscillator	
		Coil I.F. Input	
		Coil Tuned B.F.O.	
		Coil Pitch B.F.O. Tune	
L204			Coil Pitch B.F.O. Low
L205			Coil B.F.O.
L301			Choke 1H Note Filter
L302		65560	Choke 18H Smoothing
L303		65564	Choke 10H "

FUSES

Ref.	Joint Service Cat. No.	Description
F301	Z590108	Fuse 0.5 Amp
F302	Z590110	Fuse 2 Amp
F303	Z590110	Fuse 2 Amp

LOUDSPEAKERS

Ref.	Pattern No.	Description
LS201	57160 (B40) 66922 (B40A)	Monitor Loudspeaker 3 ohms

PLUGS AND SOCKETS

Ref.	A.P. or Joint Service Cat. No.	Description
PL101	Z560070	Plug 4 pin, Aerial (Mk. 4)
PL103	AP. 57771	Plug 4 pin, I.F. Output
PL201	AP. 60157	Plug 12 pin, I.F. Unit/RF Unit
PL203	Z560080	Plug 6 pin, Outputs (Mk. 4)
PL204	AP. 60158	Plug 8 pin, I.F./Power Unit
PL205	AP. 60157	Plug 12 pin, I.F./Power Unit
PL301	Z560050	Plug 2 pin, Mains (Mk. 4)
SK101	AP. 60156	Socket 12 way, R.F./I.F. Unit
SK102	AP. 60451	Socket Coaxial, R.I.S.
SK201	AP. 57772	Socket 4 way I.F. Input
SK202	AP. 60451	Socket Coaxial R.E.C.
SK203	AP. 60451	Socket Coaxial R.E.B.
SK301	AP. W8369	Socket 8 way I.F./Power Unit
SK302	AP. 60156	Socket 12 way I.F./Power Unit

LAMPS

Ref.	J.S. Cat. No.	Description
LP101-107	X951225	Lamp Pilot 6.5V 0.3A

SWITCHES

Ref.	Pattern No.	Description
SW101	65638	Switch Lamps, Band Indication
SW102		Wafer Crystal, Crystal Switch
SW201		Switch 3 Position, Bandwidth
SW202		Switch 6 Position, System
SW203	W9836A	Switch Single Pole, Limiter
SW204	60448 or 50068	Switch Single Pole, Dummy Load
SW205		Switch Single Pole, Monitor L.S.
SW301		Switch Double Pole, Mains

MISCELLANEOUS

Ref.	Pattern No.	Description
XL101	As Req'd. A/500	Crystal 2 Pin, Local Oscillator
XL201		Crystal 500 kc/s, Calibrate
JK301	676A	Jack 3 Pole, Phones
JK302	676A	Jack 3 Pole, Phones

FIG. 12

R		101	103	104	105	106	108	109		110	111	112	113	114		116	117	118	120	R		
											122		123			124		125				
C		101	103	105	107	108				113	114	115	116	119	120	121	122	126	124	127	128	129
		141	142	143	102	104	111	112	106	131	135			136		138	140	123	137		125	130
		PL101	RV102				V101						V102		TR103		V103	V104	SK101			
MISC		SWM	TR101	SW101				TR102			L102	SW102b	XL101	SW102c		L101	SW102d	TR104	PL103			MISC
		SW102a	LP101-107	RV125			SK102															

R.F. UNIT

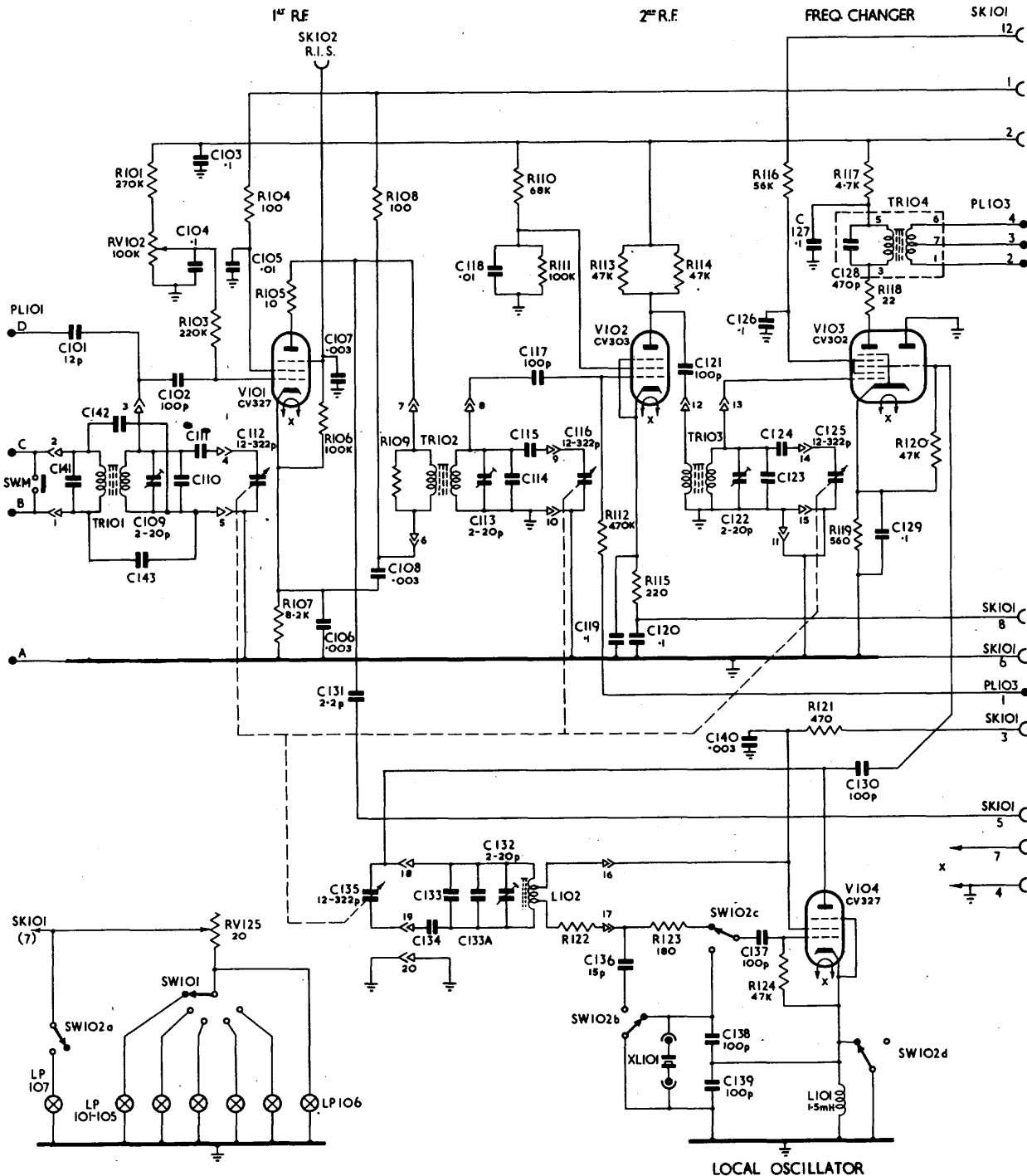

NOTES:-

1. THE FOLLOWING COMPONENTS ARE ONLY FITTED TO PATT. 57140C. - C141, C142, C143 AND SWM.
2. THE HIGH IMPEDANCE AERIAL CONNECTION TO PL101 D, INCLUDING C101, IS OMITTED IN PATT. 57140C.
3. C133A IS FITTED ONLY IN PATT. 57140B/C.
4. REFER TO FIG. 2 PT.3 FOR VALUES OF COMPONENTS IN TURRET COMPARTMENTS

209	212	231	236	211	232		219	225		301	302	303	314	307	313		R
210a	213	235	229				221	223	226		302			306	308		
210b	227	228	233	237	230		222			310	304						
	232	217	216	215	214		226	227	230		306	318	303	315	316		309
		233	234	235			224	229	225					319	317	313	314
		237	236				228	231						305	304		310
V203	V204a	TR203	V206	RV220	V205	V204b	SW202h	PL204	SK301	V304	L302	V303	RV309	SW301			
XL201	SK202	L202	L205	SW202n	SW203	SW206c	PL204	SK301	V301	L304	V302	FS301	SK302	PL301			MISC
L203	L204				SW202f	SW206b	RV224	SK203	RV305	TR204	TR301	TR302	FS302	FS303			

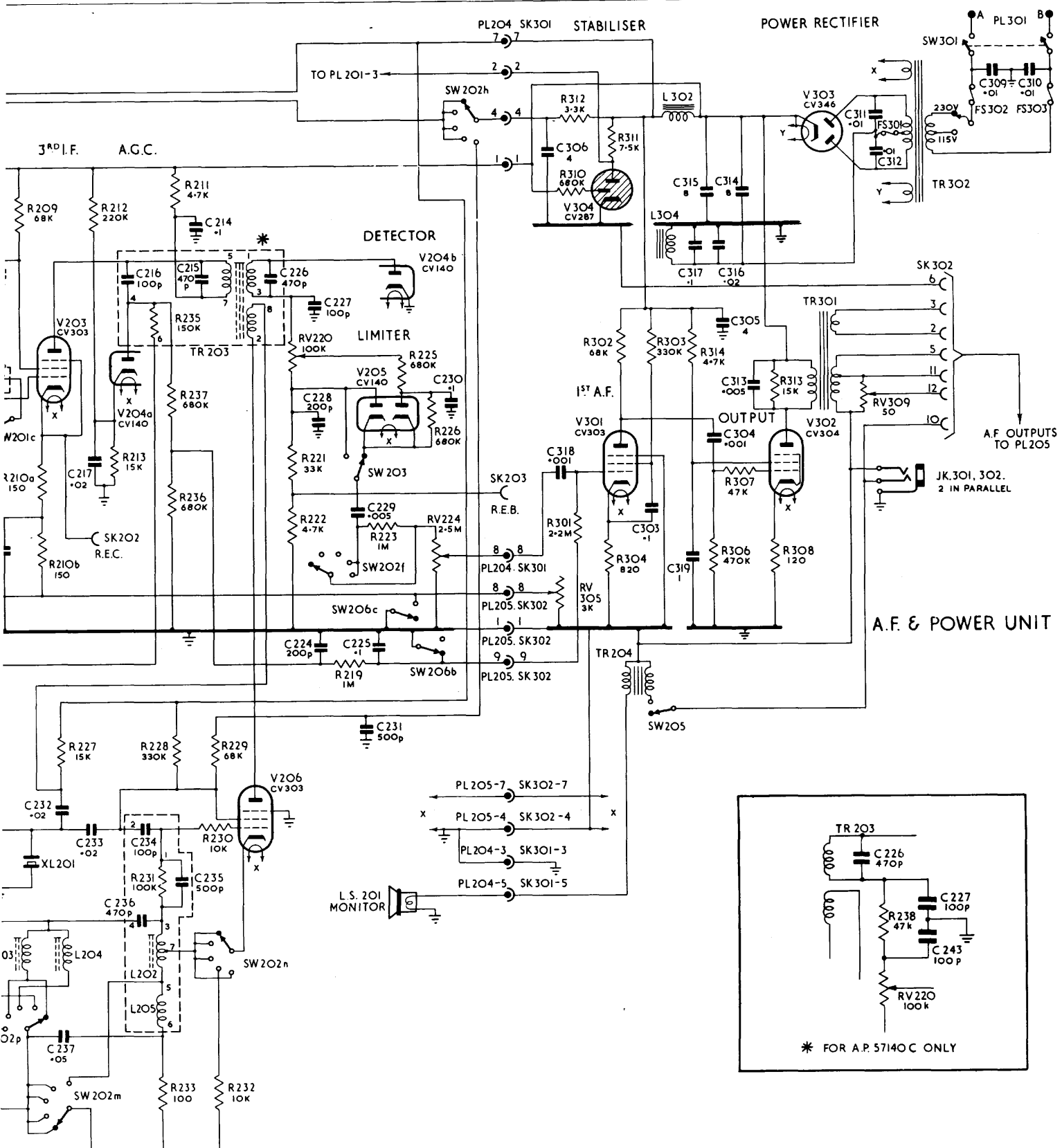

RECEIVER B40. A.P. 57140B/C. CIRCUIT DIAGRAM.

R	201 202 203 234 218	204	206 205 207	208	209 210a 210b 227	212 213	216 233	231 236 235 228 23	
C	201 238	202 203	205 204	206	240 242 222	241 218 211	212 213 237	216 234 236	
MISC	SW201a PL201 SK201	L201 TL	V201 PL203	TR201 SW206a SW204	SW201b SW206d PL205	SW201f SW201j XL202	SW201g SW201h SW202j L206	V202 TR202 SW201c SW202k,m,p,q L203 L204	V203 XL201 SK202 V204a L202 L205

I.F. UNIT

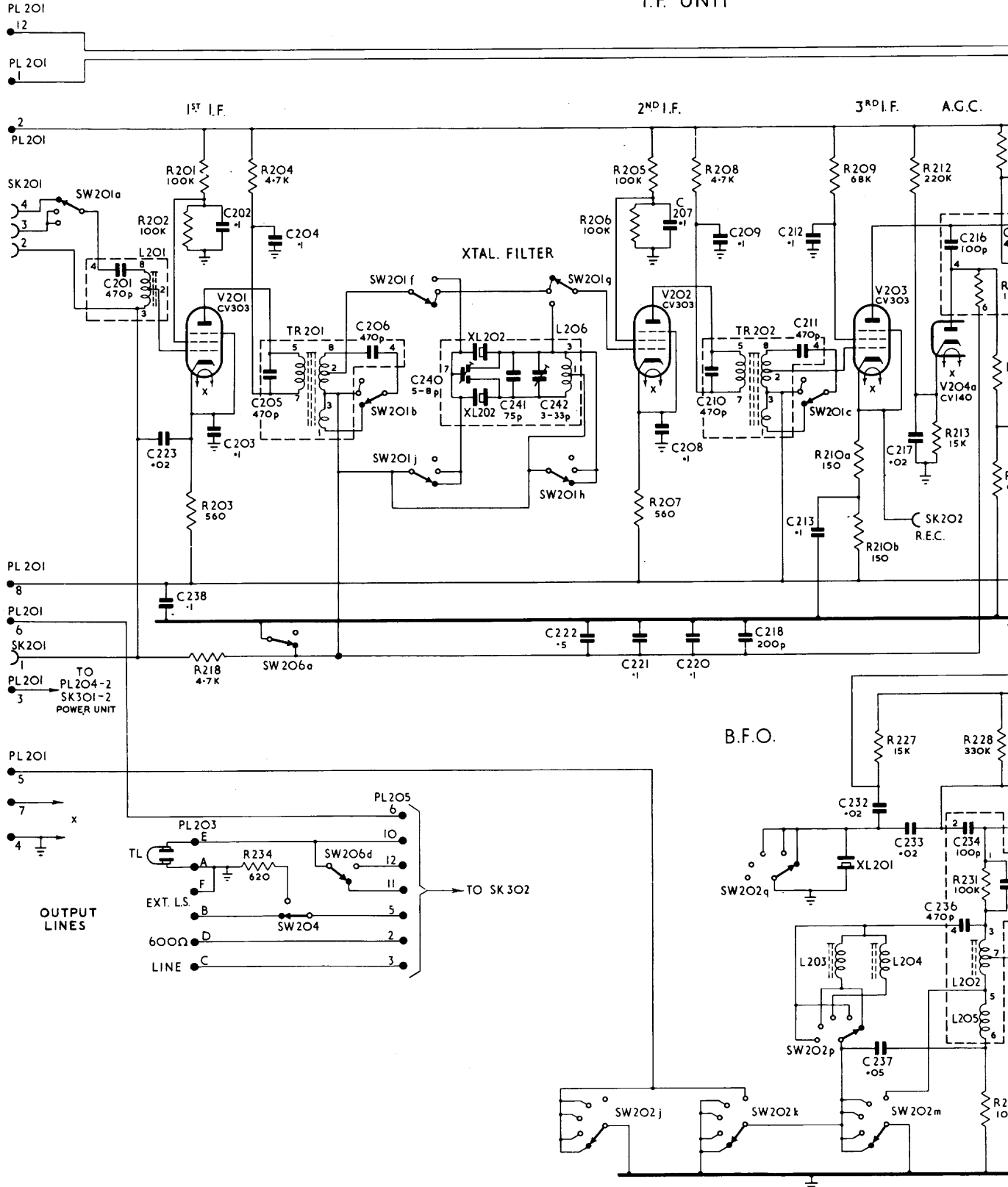

COMPONENTS LIST RECEIVER B40 PATTERNS 57140B/C
CAPACITORS

Ref.	A.P. or Joint Service Cat. No.	Value	Tol.	Rating	Remarks
C101	Z131175	12 pF	10%	500V	Not in AP.57140C
C102	Z123194	100 pF	20%	350V	
C103	Z115095	0.1 μ F	20%	350V	
C104	Z115095	0.1 μ F	20%	350V	
C105	Z124407	0.01 μ F	20%	350V	
C106	Z124477	0.003 μ F	20%	350V	Variable Band 4
C107	Z124477	0.003 μ F	20%	350V	
C108	Z124477	0.003 μ F	20%	350V	
C109	≡ AP.52437	2-20 pF	10%		
C110	Z131178	15 pF	10%	500V	
C110	Z131194	47 pF	5%	500V	Band 5
C111	Z125666	600 pF	5%	350V	Band 4
C111	Z125664	450 pF	5%	350V	Band 5
C112	AP. 60189	12-322 pF			Ganged Capacitor Section
C113	≡ AP.52437	2-20 pF	10%		Variable
C114	Z131169	6.8 pF	10%	500V	Band 2
C114	Z131058	10 pF	10%	500V	Band 3
C114	Z131186	27 pF	10%	500V	Band 4
C114	Z131197	56 pF	5%	500V	Band 5
C115	Z125666	600 pF	5%	350V	Band 4
C115	Z125664	450 pF	5%	350V	Band 5
C116	AP. 60189	12-322 pF			Ganged Capacitor Section
C117	Z123194	100 pF	20%	350V	
C118	Z124407	0.01 μ F	20%	350V	
C119	Z115095	0.1 μ F	20%	350V	
C120	Z115095	0.1 μ F	20%	350V	Variable Band 2 Band 3
C121	Z123194	100 pF	20%	350V	
C122	≡ AP.52437	2-20 pF	10%		
C123	Z131169	6.8 pF	10%	500V	
C123	Z131058	10 pF	10%	500V	
C123	Z131184	22 pF	10%	500V	Band 4
C123	Z131194	47 pF	10%	500V	Band 5
C124	Z125664	450 pF	5%	350V	Band 5
C124	Z125666	600 pF	5%	350V	Band 4
C125	AP. 60189	12-322 pF			Ganged Capacitor Section
C126	Z115095	0.1 μ F	20%	350V	
C127	Z115095	0.1 μ F	20%	350V	
C128	Z125665	470 pF	5%	350V	
C129	Z115095	0.1 μ F	20%	350V	
C130	Z131206	100 pF	10%	500V	

≡ Replacement component to be Z160009.

CAPACITORS (Cont'd.)

Ref.	A.P. or Joint Service Cat. No.	Value	Tol.	Rating	Remarks
C131	Z131165	2.2 pF	0.5 pF	500V	Variable Band 1
C132	* AP. 52437	2-20 pF	10%	500V	
C133	Z131186	27 pF	10%	500V	
C133	Z131181	18 pF	10%	500V	
C133	Z132244	12 pF	10%	500V	
C133	Z132276	22 pF	5%	350V	Band 4
C133	Z125608	33 pF	5%	500V	Band 5
C133A		Not fitted			Band 1
C133A		Not fitted			Band 2
C133A	Z132268	6.8 pF	10%	500V	Band 3
C133A	Z125704	10 pF	5%	500V	Band 4
C133A	Z132279	27 pF	5%	350V	Band 5
C134	Z125476	470 pF	5%	350V	Band 1
C134	Z126350	1050 pF	5%	350V	Band 2
C134	Z126351	2200 pF	10%	350V	Band 3
C134	W6424	500 pF	5%	350V	Band 4
C134	Z125450	390 pF	5%	350V	Band 5
C135	60189	12-322 pF			Gang. Cap. Sect.
C136	Z131178	15 pF	10%	500V	
C137	Z131206	100 pF	10%	350V	
C138	Z123194	100 pF	20%	350V	
C139	Z123194	100 pF	20%	350V	
C140	Z124477	0.003 μ F	20%	350V	
C141	Z132277	22 pF	10%	500V	Band 2
C141	Z132073	15 pF	10%	500V	Band 3
C142	Z132280	27 pF	10%	500V	Bands 1/2
C142	Z132274	18 pF	10%	500V	Band 3
C143	Z132280	27 pF	10%	500V	Bands 1/2
C143	Z132274	18 pF	10%	500V	Band 3
C201	Z125665	470 pF	5%	350V	
C202	Z115506	0.1 μ F	20%	350V	
C203	Z115095	0.1 μ F	20%	350V	
C204	Z115095	0.1 μ F	20%	350V	
C205	Z125665	470 pF	5%	350V	
C206	Z125665	470 pF	5%	350V	
C207	Z115095	0.1 μ F	20%	350V	
C208	Z115095	0.1 μ F	20%	350V	
C209	Z115095	0.1 μ F	20%	350V	
C210	Z125665	470 pF	5%	350V	
C211	Z125665	470 pF	5%	350V	

* Replacement component to be Z160009.

CAPACITORS (Cont'd.)

Ref.	A.P. or Joint Service Cat. No.	Value	Tol.	Rating	Remarks
C212	Z115095	0.1 μ F	20%	350V	
C213	Z115095	0.1 μ F	20%	350V	
C214	Z115095	0.1 μ F	20%	350V	
C215	Z125665	470 pF	5%	350V	
C216	Z123194	100 pF	20%	350V	
C217	Z115504	0.02 μ F	20%	750V	
C218	Z123274	200 pF	20%	350V	
C220	Z115095	0.1 μ F	20%	350V	
C221	Z115095	0.1 μ F	20%	350V	
C222	Z115148	0.5 μ F	20%	350V	
C223	Z115504	0.02 μ F	20%	750V	
C224	Z123274	200 pF	20%	350V	
C225	Z115095	0.1 μ F	20%	350V	
C226	Z125665	470 pF	5%	350V	
C227	Z123194	100 pF	20%	350V	
C228	Z123274	200 pF	20%	350V	
C229	Z115502	0.005 μ F	20%	1000V	
C230	Z115095	0.1 μ F	20%	350V	
C231	Z123456	500 pF	20%	350V	
C232	Z115504	0.02 μ F	20%	750V	
C233	Z115504	0.02 μ F	20%	750V	
C234	Z123194	100 pF	20%	350V	
C235	Z123456	500 pF	20%	350V	
C236	Z125665	470 pF	5%	350V	
C237	Z115505	0.05 μ F	20%	500V	
C238	Z115095	0.1 μ F	20%	350V	
C240		5-8 pF			Variable
C241	Z125199	75 pF	2%		Variable
C242		3-33 pF			Variable
C243	Z123194	100 pF	20%	350V	B40C only
C303	Z115506	0.1 μ F	20%	350V	
C304	Z115500	0.001 μ F	20%	1000V	
C305	Z112521	4 μ F	20%	400V	
C306	Z112521	4 μ F	20%	400V	
C309	Z124409	0.01 μ F	20%	750V	
C310	Z124409	0.01 μ F	20%	750V	
C311	Z124409	0.01 μ F	20%	750V	
C312	Z124409	0.01 μ F	20%	750V	
C313	Z115502	0.005 μ F	20%	1000V	
C314	Z112934	8 μ F	20%	400V	

CAPACITORS (Cont'd.)

Ref.	A.P. No. or Joint Service Cat. No.	Value	Tol.	Rating	Remarks
C315	Z112934	8 μ F	20%	400V	
C316	Z115516	0.02 μ F	10%	750V	
C317	Z115574	0.1 μ F	10%	350V	
C318	Z115500	0.001 μ F	20%	1000V	
C319	Z115632	1 μ F	20%	350V	

RESISTORS

Ref.	A.P. or Joint Service Cat. No.	Value	Tol.	Rating	Remarks
R101	Z223092	270k ohms	10%	$\frac{1}{2}$ W	Variable
RV102	AP. 51464A	100k ohms	10%	$\frac{1}{4}$ W	
R103	Z223080	220k ohms	10%	$\frac{1}{2}$ W	
R104	Z221110	100 ohms	10%	$\frac{1}{2}$ W	
R105	Z221002	10 ohms	10%	$\frac{1}{2}$ W	
R106	Z223038	100k ohms	10%	$\frac{1}{2}$ W	Band 1
R107	Z222123	8.2k ohms	10%	$\frac{3}{4}$ W	
R108	Z221110	100 ohms	10%	$\frac{1}{2}$ W	Band 2
R109	Z222026	1.5k ohms	10%	$\frac{1}{2}$ W	
R109	Z222005	1k ohm	10%	$\frac{1}{2}$ W	
R109	Z222038	1.8k ohms	10%	$\frac{1}{2}$ W	Band 3
R109	Z222080	3.9k ohms	10%	$\frac{1}{2}$ W	Band 4
R110	Z223018	68k ohms	10%	$\frac{3}{4}$ W	
R111	Z223038	100k ohms	10%	$\frac{1}{2}$ W	
R112	Z223122	470k ohms	10%	$\frac{1}{2}$ W	
R113	Z222216	47k ohms	10%	$\frac{3}{4}$ W	
R114	Z222216	47k ohms	10%	$\frac{3}{4}$ W	
R115	Z221152	220 ohms	10%	$\frac{1}{2}$ W	
R116	Z223009	56k ohms	10%	$\frac{3}{4}$ W	
R117	Z222089	4.7k ohms	10%	$\frac{1}{2}$ W	
R118	Z221026	22 ohms	10%	$\frac{1}{2}$ W	
R119	Z221206	560 ohms	10%	$\frac{1}{2}$ W	
R120	Z222215	47k ohms	10%	$\frac{1}{2}$ W	
R121	Z221194	470 ohms	10%	$\frac{1}{2}$ W	
R122	Z222017	1.2k ohms	10%	$\frac{1}{2}$ W	Band 1
R122	Z221185	390 ohms	10%	$\frac{1}{2}$ W	Band 2
R122	Z221143	180 ohms	10%	$\frac{1}{2}$ W	Band 3
R122	Z221068	47 ohms	10%	$\frac{1}{2}$ W	Band 4
R123	Z221143	180 ohms	10%	$\frac{1}{2}$ W	
R124	Z222215	47k ohms	10%	$\frac{1}{2}$ W	

RESISTORS (Cont'd.)

Ref.	A.P. or Joint Service Cat. No.	Value	Tol.	Rating	Remarks
RV125	A.P. 60480A	20 ohms	10%	2.5W	Variable
R201	Z223039	100k ohms	10%	$\frac{3}{4}$ W	
R202	Z223038	100k ohms	10%	$\frac{1}{2}$ W	
R203	Z221206	560 ohms	10%	$\frac{1}{2}$ W	
R204	Z222090	4.7k ohms	10%	$\frac{3}{4}$ W	
R205	Z223039	100k ohms	10%	$\frac{3}{4}$ W	
R206	Z223038	100k ohms	10%	$\frac{1}{2}$ W	
R207	Z221206	560 ohms	10%	$\frac{1}{2}$ W	
R208	Z222090	4.7k ohms	10%	$\frac{3}{4}$ W	
R209	Z223018	68k ohms	10%	$\frac{3}{4}$ W	
R210A/B	Z221131	150 ohms	10%	$\frac{1}{2}$ W	
R211	Z222090	4.7k ohms	10%	$\frac{3}{4}$ W	
R212	Z223081	220k ohms	10%	$\frac{3}{4}$ W	
R213	Z222152	15k ohms	10%	$\frac{3}{4}$ W	
R218	Z222090	4.7k ohms	10%	$\frac{3}{4}$ W	
R219	Z223164	1 Megohm	10%	$\frac{1}{2}$ W	
RV220	Z262183	100k ohms	10%	$\frac{3}{4}$ W	Variable
R221	Z222195	33k ohms	10%	$\frac{3}{4}$ W	
R222	Z222090	4.7k ohms	10%	$\frac{3}{4}$ W	
R223	Z223164	1 Megohm	10%	$\frac{1}{2}$ W	
RV224	Z262948	2.5 Megohms	10%	1W	Variable
R225	Z223143	680k ohms	10%	$\frac{1}{2}$ W	
R226	Z223143	680k ohms	10%	$\frac{1}{2}$ W	
R227	Z222153	15k ohms	10%	$\frac{3}{4}$ W	
R228	Z223102	330k ohms	10%	$\frac{3}{4}$ W	
R229	Z223018	68k ohms	10%	$\frac{3}{4}$ W	
R230	Z222131	10k ohms	10%	$\frac{1}{2}$ W	
R231	Z223038	100k ohms	10%	$\frac{1}{2}$ W	
R232	Z222132	10k ohms	10%	$\frac{3}{4}$ W	
R233	Z221111	100 ohms	10%	$\frac{3}{4}$ W	
R234	Z243173	620 ohms	5%	4.5W	
R235	Z223059	150k ohms	10%	$\frac{1}{2}$ W	
R236	Z223143	680k ohms	10%	$\frac{1}{2}$ W	
R237	Z223143	680k ohms	10%	$\frac{1}{2}$ W	
R301	Z223207	2.2 Megohms	10%	$\frac{3}{4}$ W	
R302	Z223017	68k ohms	10%	$\frac{1}{2}$ W	
R303	Z223101	330k ohms	10%	$\frac{1}{2}$ W	
R304	Z221227	820 ohms	10%	$\frac{1}{2}$ W	
RV305	Z273001	3k ohms	10%		Variable
R306	Z223122	470k ohms	10%	$\frac{1}{2}$ W	

RESISTORS (Cont'd.)

Ref.	A.P. or Joint Service Cat. No.	Value	Tol.	Rating	Remarks
R307	Z222215	47k ohms	10%	$\frac{1}{2}W$	Variable
R308	Z221123	120 ohms	10%	$\frac{3}{4}W$	
RV309	Z273001	50 ohms	10%		
R310	Z223144	680k ohms	10%	$\frac{3}{4}W$	
R311	Z244085	7.5k ohms	5%	4.5W	
R312	Z222069	3.3k ohms	10%	$\frac{3}{4}W$	
R313	Z244114	15k ohms	10%	6W	
R314	Z222090	4.7k ohms	10%	$\frac{3}{4}W$	

TRANSFORMERS

Ref.	Pattern No.	Description
TR101 to TR103	TR101 bands 1-5 5905-A.P.184026/ 7/8/9/30	Transformers R.F.
TR104 TR201 to TR203 }		Transformers I.F.
TR204	65690	Transformer A.F.
TR301	65689	Transformer A.F. - Output
TR302	67763A	Transformer Power - Mains

INDUCTORS

Ref.	Pattern No.	Description	
L101		Choke 1.5 mH, Oscillator	
L102		Coil tuned, Oscillator	
L201		Coil IF, IF Input	
L202		Coil tuned, B.F.O.	
L203		Coil Pitch, B.F.O. "Tune"	
L204		Coil Pitch, B.F.O. "Low"	
L205		Coil, Calibration coupling	
L206		Coil tuned, Crystal Filter	
L302		65560	Choke 18H. Smoothing
L304		67762	Choke 20H. Smoothing

FUSES

Ref.	Joint Service Cat. No.	Description
F301	Z590108	Fuse 0.5 Amp
F302	Z590110	Fuse 2 Amp
F303	Z590110	Fuse 2 Amp

LOUDSPEAKERS

Ref.	Pattern No.	Description
LS201	A.P.66922	Loudspeaker 3 ohms, Monitor.

PLUGS AND SOCKETS

Ref.	A.P. or Joint Service Cat. No.	Description
PL101	Z560070	Plug 4 Pin, Aerial (Mk. 4)
PL103	AP.57771	Plug 4 Pin, I.F. Output
PL201	AP.60157	Plug 12 Pin, I.F. Unit/R.F. Unit
PL203	Z560080	Plug 6 Pin, Outputs (Mk. 4)
PL204	AP.60158	Plug 8 Pin, I.F./Power Unit
PL205	AP.60157	Plug 12 Pin, I.F./Power Unit
PL301	Z560050	Plug, 2 Pin, Mains (Mk. 4)
SK101	AP.60156	Socket 12 Way, R.F./I.F. Unit
SK102	AP.60451	Socket Coaxial, R.I.S.
SK201	AP.57772	Socket 4 Way, I.F. Input
SK202	AP.60451	Socket Single, REC
SK203	AP.60451	Socket Single, REB
SK301	AP.W8369	Socket 8 Pin, I.F./A.F. and Power Unit
SK302	AP.60156	Socket 12 Pin, I.F./A.F. and Power Unit

LAMPS

Ref.	J.S. Cat. No.	Description
IP101-107	X951225	Lamp Pilot 6.5V 0.3A

SWITCHES

Ref.	A.P. or Joint Service Cat. No.	Description
SW101	65638	Switch Lamps, Band Indication
SW102		Wafer Crystal, Crystal Switch
SW201	5930-99-972-8826	Switch 3 Position, Bandwidth
SW202		Switch 5 Position, System
SW203		Switch Single Pole, Limiter

CHAPTER 3
LIST OF COMPONENTS

SWITCHES (Cont'd.)

Ref.	A.P. or Joint Service Cat. No.	Description
SW204 SW205 SW206 SW301	52805 5930-99-972-8825 60448 or 50068	Switch Single Pole, Dummy Load Switch Single Pole, Monitor L.S. Switch 2 Position, A.G.C. Switch Double Pole, Mains
S.W.M.	Z510080	Microswitch, C.A.W. (Patt. 57140C only)

MISCELLANEOUS

Ref.	Pattern No.	Description
XL201 XL101 XL202	67864	Crystal 500 kc/s, Calibrate Crystal 2 Pin, Local Oscillator Crystal, Crystal Filter
JK301 JK302	676A 676A	Jack 3 Pole, Phones Jack 3 Pole, Phones

FIG. 13

C	IO6	IO5	IO7	IO4	122	IO2	IO1	IO3	123	124	125	127	128	129	130	130	160	161	163	164	165	166	177	182	184	C	
R	PLIO1	SWIO2	LPIO1	LPIO7	RVIO1	MRI	VIO1	SKIO1	TRIO6	SWIO3b	SWIO3c	VIO2	XLIO1	TRIII	VIO3	TRII6	SKIO3	PLIO2	MSC								
MISC	SWIO1	SWIO3a	TRIO1	RVIO2																							

R. F. UNIT

1ST R.F.

2ND R.F.

FREQ. CHANGER

NOTE:-
CIRCUIT SHOWS BAND SWITCH
SET TO BAND 1. CIRCUITS
FOR OTHER BANDS ARE
SHOWN IN FIG. 8 Part 3
COMPONENTS ASSOCIATED
WITH TURRET SECTION
BANDS 2-5 ARE
OMITTED FROM THIS
DIAGRAM BUT SHOWN
IN FIG. 8 Part 3

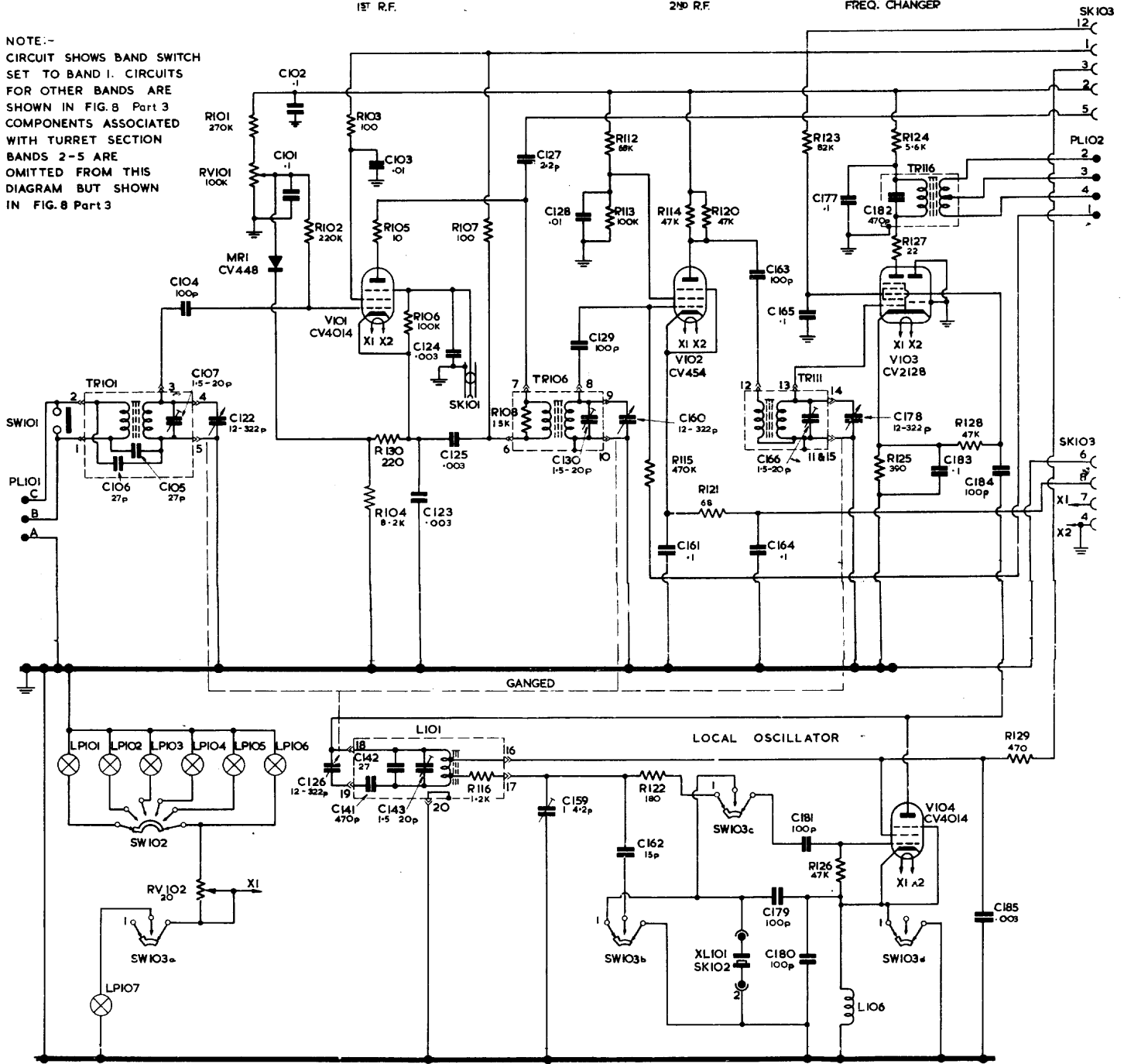
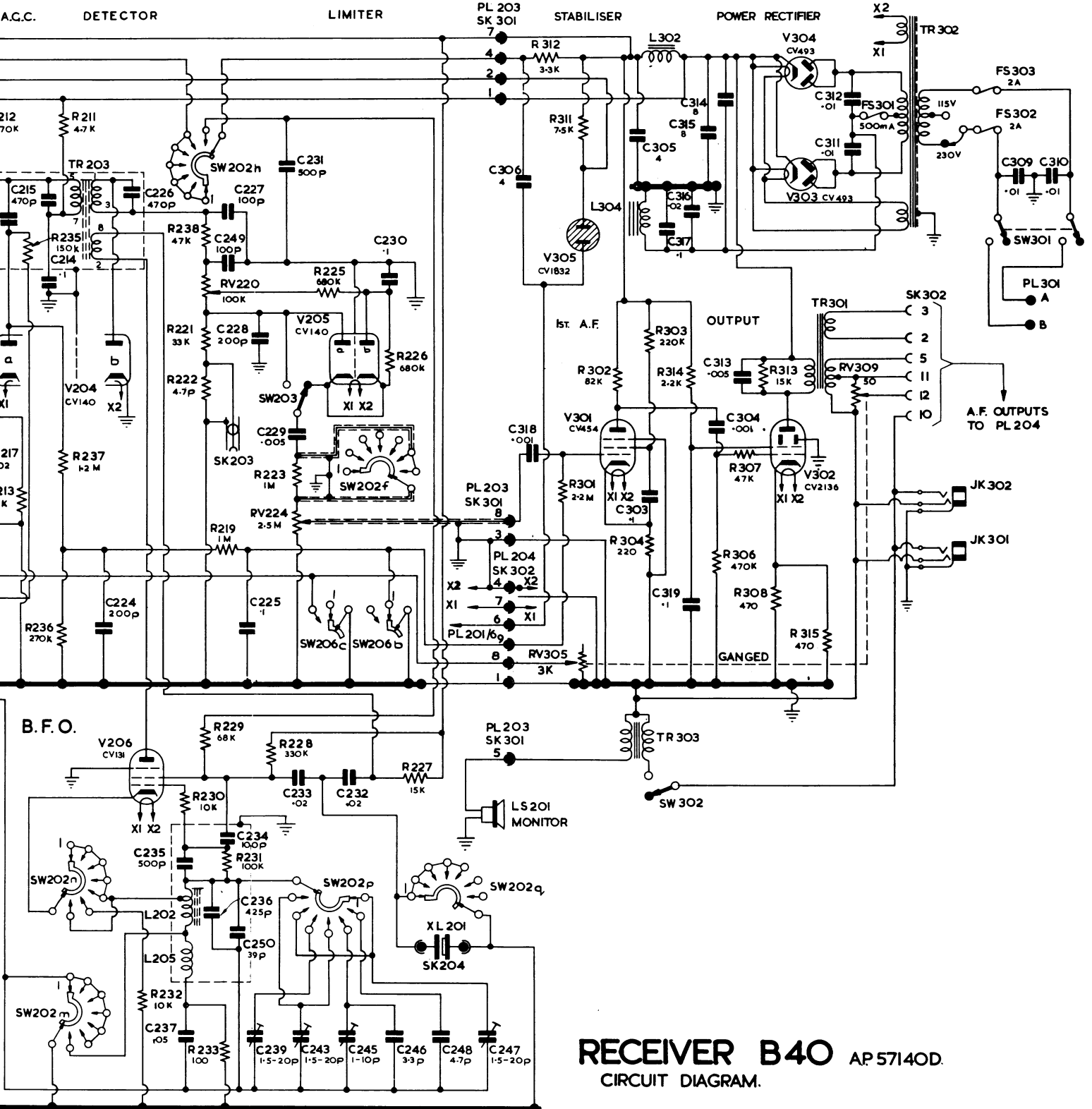

FIG. 13

216	215	226	235	227	231	233	230	306	303	317	316	315	314	312	309	310	C									
	214	224	237	236	249	228	229	318	305	319	304	313	314	311												
	235	237	232	238	229	231	223	311	301	302	303	307	313	315			R									
	213	236	233	221	222	225	228	311	304	304	314	306	308													
	TR203	SW202n	SW202m	SW202h	SW202f	SW202c	SW202g	LS201	XL201	PL203	PL204	V305	V301	TR303	V304	V303	V302	TR301	RV309	JK302	JK301	FS302	FS303	SW301	PL301	MISC.

A.F. & POWER UNIT



RECEIVER B40 AP 57140D.
CIRCUIT DIAGRAM.

C	238	201	202	204	206	240	242	241	207	210	212	217	215	216	214	224		
R		223	203	205			222	221	220		211	213	218	212	213	235	237	236
MISC.	PL 201 SK 201	SW 201a SW 202j SW 202k	L 201 PL 202	V 201	TR 201 SW 206a SW 204	SW 201f SW 201j SW 201b XL 202	SW 201g SW 201h SW 201k SW 206d L 206	V 202 PL 204	TR 202 SW 201c	V 203 SK 202	SW 202n SW 202m	TR 203 V 204b V						

I.F. UNIT

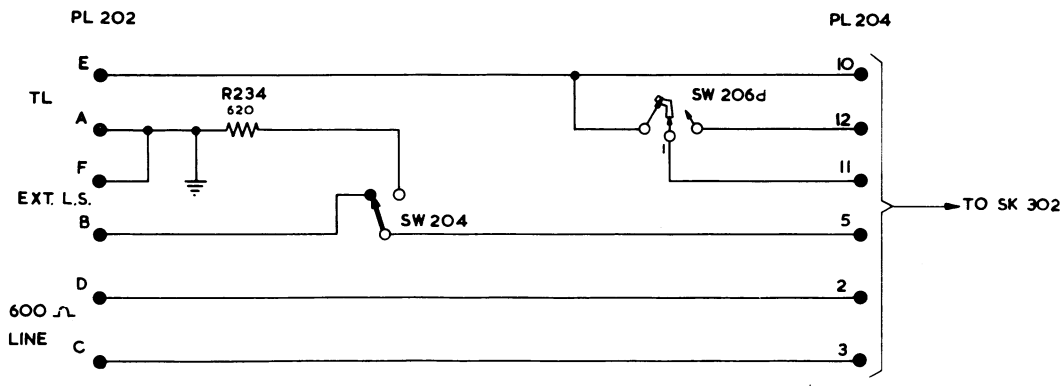
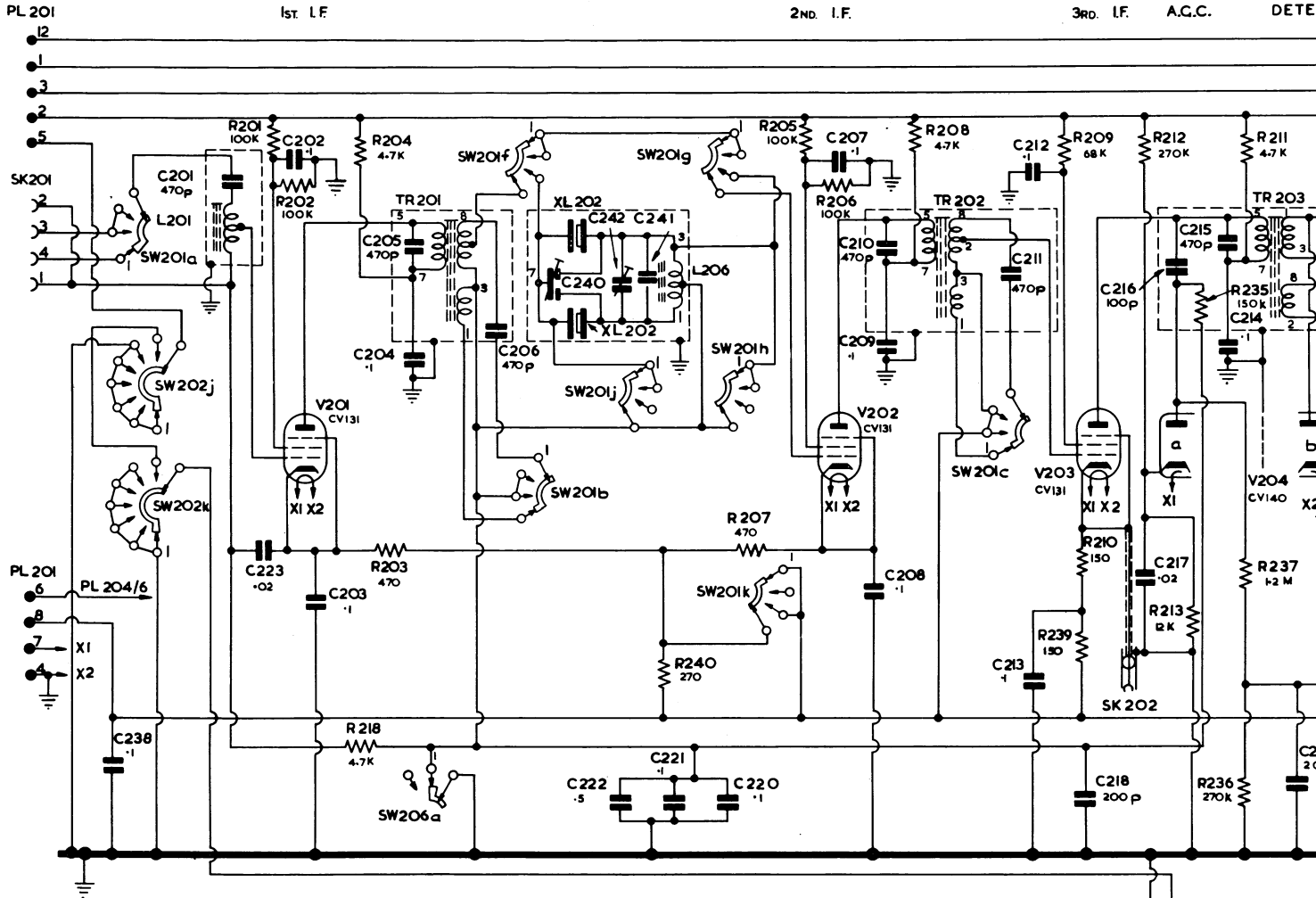

B.F.O.

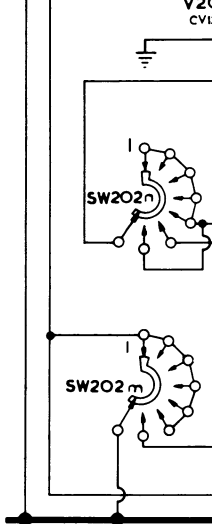

COMPONENTS LIST RECEIVER B40 A.P. 57140D
CAPACITORS

Ref.	A.P. or Joint Service Cat. No.	Value	Tol.	Rating	Remarks
C101	Z115095	0.1 μ F	20%	350V	Stud mounting
C102	Z115095	0.1 μ F	20%	350V	" "
C103	Z124407	0.01 μ F	20%	350V	
C104	Z123194	100 pF	20%	350V	
C105	Z132280	27 pF	10%	500V	
C106	Z132280	27 pF	10%	500V	
C107	Z160009	4-18 pF	10%		Variable
C108	Z132277	22 pF	10%	500V	
C109	Z132280	27 pF	10%	500V	
C110	Z132280	27 pF	10%	500V	
C111	Z160009	4-18 pF	10%		Variable
C112	Z132073	15 pF	10%	500V	
C113	Z132274	18 pF	10%	500V	
C114	Z132274	18 pF	10%	500V	
C115	Z160009	4-18 pF	10%		Variable
C116	Z160009	4-18 pF	10%		Variable
C117	Z131184	22 pF	10%	500V	
C118	Z125666	600 pF	5%	350V	
C119	Z160009	4-18 pF	10%		Variable
C120	Z132291	56 pF	5%	500V	
C121	Z123941	330 pF	2%	750V	
C122	AP. 60189	12-322 pF	+ 1/2%		Ganged Cap. Section
C123	Z124477	0.003 μ F	20%	350V	
C124	Z124477	0.003 μ F	20%	350V	
C125	Z124477	0.003 μ F	20%	350V	
C126	AP. 60189	12-322 pF	+ 1/2%		Ganged Cap. Section
C127	Z131165	2.2 pF	0.5 pF	500V	
C128	Z124407	0.01 μ F	20%	350V	
C129	Z123194	100 pF	20%	350V	
C130	Z160009	4-18 pF	10%		Variable
C131	Z160009	4-18 pF	10%		Variable
C132	Z131169	6.8 pF	10%	500V	
C133	Z160009	4-18 pF	10%		Variable
C134	Z131058	10 pF	10%	500V	
C135	Z160009	4-18 pF	10%		Variable
C136	Z131184	22 pF	10%	500V	
C137	Z125666	600 pF	5%	350V	
C138	Z160009	4-18 pF	10%		Variable
C139	Z132291	56 pF	5%	500V	
C140	Z123941	330 pF	2%	750V	

CAPACITORS (Cont'd.)

Ref.	A.P. or Joint Service Cat. No.	Value	Tol.	Rating	Remarks
C141	Z125476	470 pF	2%	350V	Variable
C142	Z131186	27 pF	10%	500V	
C143	Z160009	4-18 pF	10%		
C144	Z126350	1050 pF	5%	350V	
C145	Z131181	18 pF	10%	500V	
C146	Z160009	4-18 pF	10%		Variable
C147	Z126351	2200 pF	5%	500V	Variable
C148	Z132244	12 pF	0.5 pF	500V	
C149	AP. 61588	6.8 pF	20%	500V	
C150	Z160009	4-18 pF	10%		
C151	AP. W6424	500 pF	5%	350V	
C152	Z132276	22 pF	5%	500V	Variable
C153	Z125704	10 pF	5%	350V	
C154	Z160009	4-18 pF	10%	350V	
C155	Z125450	390 pF	5%	350V	
C156	Z132282	33 pF	5%	500V	
C157	Z125608	33 pF	5%	350V	Variable Variable (OSC. TRIM) W & RC31-14 Ganged Capacitor Section
C158	Z160009	4-18 pF	10%		
C159		1-4.2 pF			
C160	AP. 60189	12-322 pF	+1%		
C161	Z115095	0.1 μF	20%	350V	
C162	Z131178	15 pF	10%	500V	Stud mounting " "
C163	Z123194	100 pF	20%	350V	
C164	Z115095	0.1 μF	20%	350V	
C165	Z115095	0.1 μF	20%	350V	
C166	Z160009	4-18 pF	10%		
C167	Z160009	4-18 pF	10%		Variable
C168	Z131169	6.8 pF	10%	500V	Variable
C169	Z160009	4-18 pF	10%		
C170	Z131058	10 pF	10%	500V	
C171	Z160009	4-18 pF	10%		Variable
C172	Z131184	22 pF	10%	500V	Variable
C173	Z125666	600 pF	5%	350V	
C174	Z160009	4-18 pF	10%		
C175	Z131194	47 pF	5%	500V	
C176	Z123941	330 pF	2%	750V	
C177	Z115095	0.1 μF	20%	350V	Stud mounting Ganged Capacitor Section
C178	AP. 60189	12-322 pF	+1%		
C179	Z123194	100 pF	20%	350V	Stud mounting Ganged Capacitor Section
C180	Z123194	100 pF	20%	350V	

CAPACITORS (Cont'd.)

Ref.	A.P. or Joint Service Cat. No.	Value	Tol.	Rating	Remarks
C181	Z131206	100 pF	10%	350V	Stud mounting
C182	Z125665	470 pF	20%	350V	
C183	Z115095	0.1 μ F	20%	350V	
C184	Z131206	100 pF	10%	350V	
C185	Z124477	0.003 μ F	20%	350V	
C186	Z123926	120 pF	2%	750V	
C187	Z123926	120 pF	2%	750V	
C188	Z123926	120 pF	2%	750V	
C189	Z131169	6.8 pF	10%	500V	
C201	Z125665	470 pF	5%	350V	Stud mounting " "
C202	Z115506	0.1 μ F	20%	350V	
C203	Z115095	0.1 μ F	20%	350V	
C204	Z115095	0.1 μ F	20%	350V	
C205	Z125665	470 pF	5%	350V	
C206	Z125665	470 pF	5%	350V	Stud mounting " " " "
C207	Z115095	0.1 μ F	20%	350V	
C208	Z115095	0.1 μ F	20%	350V	
C209	Z115095	0.1 μ F	20%	350V	
C210	Z125665	470 pF	5%	350V	
C211	Z125665	470 pF	5%	350V	Stud mounting " " " "
C212	Z115095	0.1 μ F	20%	350V	
C213	Z115095	0.1 μ F	20%	350V	
C214	Z115095	0.1 μ F	20%	350V	
C215	Z125665	470 pF	5%	350V	
C216	Z123194	100 pF	20%	350V	No Capacitor Stud mounting
C217	Z115504	0.02 μ F	20%	750V	
C218	Z123274	200 pF	20%	350V	
C219					
C220	Z115095	0.1 μ F	20%	350V	
C221	Z115095	0.1 μ F	20%	350V	Stud mounting
C222	Z115148	0.5 μ F	20%	350V	
C223	Z115504	0.02 μ F	20%	750V	
C224	Z123274	200 pF	20%	350V	
C225	Z115095	0.1 μ F	20%	350V	
C226	Z125665	470 pF	5%	350V	Stud mounting
C227	Z123194	100 pF	20%	350V	
C228	Z123274	200 pF	20%	350V	
C229	Z115502	0.005 μ F	20%	1000V	
C230	Z115095	0.1 μ F	20%	350V	

CAPACITORS (Cont'd.)

Ref.	A.P. or Joint Service Cat. No.	Value	Tol.	Rating	Remarks
C231	Z123456	500 pF	20%	350V	
C232	Z115504	0.02 μ F	20%	750V	
C233	Z115504	0.02 μ F	20%	750V	
C234	Z123194	100 pF	20%	350V	
C235	Z123456	500 pF	20%	350V	
C236		425 pF	5%	350V	Lemco 1510
C237	Z115505	0.05 μ F	20%	500V	
C238	Z115095	0.1 μ F	20%	350V	Stud mounting
C239	Z160009	4-18 pF	10%		Variable
C240		1.5-8 pF			Variable - Oxley Diff D.V.C. 1-5/8
C241		75 pF	2%	350V	Lemco 1510
C242	Z167006	3-30 pF			Variable W and R C30-01
C243	Z160009	4-18 pF	10%		Variable
C245		1-10 pF			Variable W and R C31/11A
C246	Z132419	3.3 pF	0.5 pF	500V	
C247	Z160009	4-18 pF	10%		Variable
C248	Z132420	4.7 pF	0.5 pF	500V	
C249	Z123194	100 pF	20%	350V	
C250	Z132285	39 pF	5%	500V	
C303	Z115506	0.1 μ F	20%	350V	
C304	Z115500	0.001 μ F	20%	1000V	
C305	Z112521	4 μ F	20%	400V	
C306	Z112521	4 μ F	20%	400V	
C309	Z124409	0.01 μ F	20%	750V	
C310	Z124409	0.01 μ F	20%	750V	
C311	Z124409	0.01 μ F	20%	750V	
C312	Z124409	0.01 μ F	20%	750V	
C313	Z115502	0.005 μ F	20%	1000V	
C314		8 μ F	20%	400V	TCC Type 82
C315		8 μ F	20%	400V	" " "
C316	Z115516	0.02 μ F	10%	350V	
C317		0.1 μ F	10%	350V	TCC Type CP.45N
C318	Z115500	0.001 μ F	20%	400V	
C319	Z115632	1 μ F	20%	350V	

RESISTORS, CARBON INSULATED FIXED GRADE 2

Unless otherwise stated

Ref.	A.P. or Joint Service Cat. No.	Value	Tol.	Rating	Remarks
R101	Z223092	270k ohms	10%	$\frac{1}{2}W$	
R102	Z223080	220k ohms		$\frac{1}{2}W$	
R103	Z221110	100 ohms		$\frac{1}{2}W$	
R104	Z222123	8.2k ohms		$\frac{3}{4}W$	
R105	Z221002	10 ohms		$\frac{1}{2}W$	
R106	Z223038	100k ohms		$\frac{1}{2}W$	
R107	Z221110	100 ohms		$\frac{1}{2}W$	
R108	Z222026	1.5k ohms		$\frac{1}{2}W$	
R109	Z222005	1k ohm		$\frac{1}{2}W$	
R110	Z222038	1.8k ohms		$\frac{1}{2}W$	
R111	Z222080	3.9k ohms		$\frac{1}{2}W$	
R112	Z223018	68k ohms		$\frac{3}{4}W$	
R113	Z223038	100k ohms		$\frac{1}{2}W$	
R114	Z222216	47k ohms		$\frac{3}{4}W$	
R115	Z223122	470k ohms		$\frac{1}{2}W$	
R116	Z222017	1.2k ohms		$\frac{1}{2}W$	
R117	Z221185	390 ohms		$\frac{1}{2}W$	
R118	Z221143	180 ohms		$\frac{1}{2}W$	
R119	Z221068	47 ohms		$\frac{1}{2}W$	
R120	Z222216	47k ohms		$\frac{3}{4}W$	
R121	Z221089	68 ohms		$\frac{1}{2}W$	
R122	Z221143	180 ohms		$\frac{1}{2}W$	
R123	Z223030	82k ohms		$\frac{3}{4}W$	
R124	Z222101	5.6k ohms		$\frac{1}{2}W$	
R125	Z221185	390 ohms		$\frac{1}{2}W$	
R126	Z222215	47k ohms	$\frac{1}{2}W$		
R127	Z221026	22 ohms	$\frac{1}{2}W$		
R128	Z222215	47k ohms	$\frac{1}{2}W$		
R129	Z221194	470 ohms	$\frac{1}{2}W$		
R130	Z221152	220 ohms	$\frac{1}{2}W$		
R201	Z203039	100k ohms	$\frac{3}{4}W$		
R202	Z223038	100k ohms	$\frac{1}{2}W$		
R203	Z221194	470 ohms	$\frac{1}{2}W$		
R204	Z222090	4.7k ohms	$\frac{3}{4}W$		
R205	Z203039	100k ohms	$\frac{3}{4}W$		
R206	Z223038	100k ohms	$\frac{1}{2}W$		
R207	Z221194	470 ohms	$\frac{1}{2}W$		
R208	Z222090	4.7k ohms	$\frac{3}{4}W$		
R209	Z223018	68k ohms	$\frac{3}{4}W$		
R210	Z221131	150 ohms	$\frac{1}{2}W$		

RESISTORS (Cont'd.)

Ref.	A.P. or Joint Service Cat. No.	Value	Tol.	Rating	Remarks	
R211	Z222090	4.7k ohms	}	$\frac{3}{4}W$		
R212	Z223093	270k ohms		$\frac{3}{4}W$		
R213	Z222143	12k ohms		$\frac{1}{2}W$		
R218	Z222090	4.7k ohms		$\frac{3}{4}W$		
R219	Z223164	1 Megohm		$\frac{1}{2}W$		
R221	Z222195	33k ohms		$\frac{3}{4}W$		
R222	Z222090	4.7k ohms		$\frac{3}{4}W$		
R223	Z223164	1 Megohm		$\frac{1}{2}W$		
R225	Z223143	680k ohms		$\frac{1}{2}W$		
R226	Z223143	680k ohms		$\frac{1}{2}W$		
R227	Z222153	15k ohms		$\frac{3}{4}W$		
R228	Z223102	330k ohms		$\frac{3}{4}W$		
R229	Z223018	68k ohms		$\frac{3}{4}W$		
R230	Z222131	10k ohms		$\frac{1}{2}W$		
R231	Z223038	100k ohms		$\frac{1}{2}W$		
R232	Z222132	10k ohms		$\frac{3}{4}W$		
R233	Z221111	100 ohms		$\frac{3}{4}W$		
R234	Z243173	620 ohms		$4\frac{1}{2}W$		Wire wound
R235	Z223059	150k ohms		$\frac{1}{2}W$		
R236	Z223092	270k ohms	$\frac{1}{2}W$			
R237	Z223176	1.2M ohms	$\frac{1}{2}W$			
R238	Z222216	47k ohms	$\frac{1}{2}W$			
R239	Z221131	150 ohms	$\frac{1}{2}W$			
R240	Z221164	270 ohms	$\frac{1}{2}W$			
R301	Z223207	2.2M ohms	}	$\frac{3}{4}W$		
R302	Z223029	82k ohms		$\frac{1}{2}W$		
R303	Z223080	220k ohms		$\frac{1}{2}W$		
R304	Z221152	220 ohms		$\frac{1}{2}W$		
R306	Z223122	470k ohms		$\frac{1}{2}W$		
R307	Z222215	47k ohms		$\frac{1}{2}W$		
R308	Z221195	470 ohms	$\frac{3}{4}W$			
R311	Z244085	7.5k ohms	}	$4\frac{1}{2}W$	Wire wound	
R312	Z222069	3.3k ohms		$\frac{3}{4}W$	}	Wire wound
R313	Z244114	15k ohms		6W		
R314	Z222048	2.2k ohms	}	$\frac{3}{4}W$		
R315	Z221195	470 ohms		$\frac{3}{4}W$		

VARIABLE RESISTORS

Ref.	A.P. or Joint Service Cat. No.	Value	Tol.	Rating	Remarks
RV101	AP.51464A	100k ohms	20%	$\frac{1}{2}$ W	Anti-Cross-Mod. Lamps -Brilliance- Limiter A.F. GAIN Ganged R.F. GAIN A.F.
RV102	AP.60480A	20 ohms	10%	2.5W	
RV220	Z262183	100k ohms	20%	0.1W	
RV224	Z262948	2.5M ohms	20%	0.1W	
RV305 } RV309 }	Z273001	3k ohms 50 ohms	10%		

TRANSFORMERS

Ref.	A.P. or Joint Service Cat. No.	Description
TR101/115	TR101 bands 1-5 5905-A.P.184.026/ 7/8/9/30	R.F. Transformers, Tuned Bands 1-5
TR116		I.F. Transformer
TR201 } TR202 } TR203 }		I.F. Transformers
TR301	AP.65689	Audio Output Transformer
TR302	AP.67763A	Mains Transformer
TR303	AP65690	Monitor L.S. Transformer

INDUCTORS

Ref.	A.P. or Joint Service Cat. No.	Description
L101 } to } L105 }		Coils, Tuned - Local Oscillator Bands 1 - 5
L106		Choke 1.5 mH - Local Oscillator
L201		Coil, tuned (I.F.)
L202		Coil, tuned B.F.O.
L205		Coil B.F.O.
L302	AP.65560	Choke 18-25H - Smoothing
L304	AP.67762	Choke 20H - Smoothing

CHAPTER 3
LIST OF COMPONENTS

FUSES

Ref.	A.P. or Joint Service Cat. No.	Description
F301 F302) F303)	Z590108 Z590110	500 mA Cartridge Fuse 2A " "

LOUDSPEAKER

Ref.	Pattern No.	Description
LS201	66922	Loudspeaker 3 ohms (Monitor)

PLUGS AND SOCKETS

Ref.	A.P. or Joint Service Cat. No.	Description
PL101 PL102 PL201 PL202 PL203	Z560070 AP.57771 AP.60157 Z560080 AP.60158	4 Pin Mark 4 - Aerial Input 4 Pin - Inter-connecting (R.F./I.F. Units) 12 Pin - Inter-connecting (R.F./I.F. Units) 6 Pin - Mark 4 - Audio Output 8 Pin - Inter-connecting (I.F./A.F. - Power Unit)
PL204	AP.60157	12 Pin - Inter-connecting (I.F./A.F. - Power Units)
PL301	Z560050	2 Pin Mark 4 - Mains Input
SK101 SK102 SK103 SK201 SK202	AP.60451 AP.60156 AP.57772 AP.60451	Coaxial - R.I.S. Crystal - Local Oscillator 12 Pin - Inter-connecting (R.F./I.F. Units) 4 Pin - Inter-connecting (R.F./I.F. Units) Coaxial - R.E.C.
SK203 SK204 SK301	AP.60451 AP.W8369	Coaxial - R.E.B. Crystal B.F.O. 8 Pin - Inter-connecting (I.F./A.F. and Power Units)
SK302	AP.60156	12 Pin - Inter-connecting (I.F./A.F. and Power Units)

LAMPS

Ref.	J.S. Cat. No.	Description
LP101-107	X951225	Pilot Lamps 6.5V 0.3A M.E.S.

SWITCHES

Ref.	A.P. or Joint Service Cat. No.	Description
SW101 SW102 SW103 SW201 SW202		Micro Switch - Burgess V3N LR1 Switch Lamps Crystal Switch Switch 3 Position - Bandwidth Switch 7 Position - System -
SW203 SW204	5930-99-972-8826 AP9836A	Switch 2 Position - Limiter - Switch 2 Position - Dummy Load -
SW206 SW301	5930-99-972-8825 AP.60448 or) AP.50068	Switch 2 Position - A.G.C. - Switch 2 Position - Mains
SW302	52805	Switch 2 Position - Monitor L.S.

MISCELLANEOUS

Ref.	A.P. or Joint Service Cat. No.	Description
MR1 XL101 XI201 XL202 JK301/2	CV.448 AP.67864 AP.676A	Crystal - Rectifier - Crystal - Local Oscillator - Crystal 500 kc/s - B.F.O. (calibrate) - Crystal 500 kc/s - Crystal Filter - Jack 3 pole

CHAPTER 4RECEIVER PATTERN DIFFERENCESLIST OF CONTENTS

	<u>Para.</u>
Introduction	1-2
AP.5714OA	3
AP.5714OB	4
AP.5714OC	5
AP.5714OD	6-7

	<u>Fig.</u>
Receiver B40 AP.5714OC/D. Turret Modifications	1

CHAPTER 4RECEIVER PATTERN DIFFERENCESIntroduction

1. The principal differences between the five patterns of the receiver are detailed below. As a general rule, subsequent patterns retain all improvement modifications and special facilities incorporated in the earlier types of the receiver. Thus B40B retains all the modifications of B40A, whilst incorporating additional modifications.
2. It should be remembered that the identity of a component in the circuit drawings of one pattern of receiver, is not necessarily the same in the circuit drawings of other patterns of the B40 receiver.

A.P.57140A

3. This pattern differs from A.P.57140 as follows:-
 - (a) The position of the noise limiter valve on the IF Unit is changed, to provide additional space for the fitting of an improved design of monitor loudspeaker.
 - (b) A tensioning device is fitted to the driving chain of the tuning mechanism to minimise backlash.
 - (c) The LIMITER and AF GAIN potentiometers (RV220 and RV224) are brought out to control knobs, instead of the screwdriver adjustment.
 - (d) The mains transformer TR302 is an oil filled type instead of the original open type. Three webs are cut away in the chassis to give clearance.
- NOTE: In accordance with Modification No. 5 (B.R.1917), this transformer should now be replaced by A.P.65561B.
- (e) A protection bar is fitted in front of the IF transformer trimmers to prevent damage when the unit is withdrawn from the case.
 - (f) A portion of the left-hand side plate is cut away to facilitate removal of the crystal.
 - (g) The screen of the RF Unit is bent to prevent vibration.
 - (h) The size of the dowel holes is increased to bring the IF chassis forward.
 - (j) The manual GAIN control RV305/309 is fitted with a ganged potentiometer of improved design.
 - (k) Certain reconditioned receivers will have temperature compensated capacitors fitted in the local oscillator, RF and b.f.o. circuits as in the case of the B40B/C/D.

A.P. 57140B

4. This pattern differs from A.P. 57140A as follows:-
- (a) A redesigned tuning drive is fitted.
 - (b) A 500 kc/s crystal filter is fitted in the IF chain, between the first two stages. The mounting of the filter is effected by removing the secondary of the IF coil L201, to the position formerly occupied by the monitor loudspeaker transformer TR204, this last-mentioned component is moved to the AF and Power Unit. The position formerly occupied by the transformer secondary L201 is taken by the IF transformer TR201, and the crystal filter (L206, XL202 etc.) positioned in the place vacated by TR201.
 - (c) The SYSTEM switch SW202 has five instead of six positions. The manual position is no longer required, as a separate a.g.c. switch SW206 is fitted to provide facilities for both manual and automatic gain control, in all positions of the SYSTEM switch. The a.g.c. switch is fitted in the position formerly occupied by the monitor loudspeaker switch SW205, this in turn being moved to the AF and Power Unit above the mains switch.
 - (d) The a.g.c. time constants are modified. The two load resistors R214/5, both of 330k ohms, are changed to R236/7, both of 680k ohms; C219, R217 and switches SW202b/c are removed and R216, (68k ohms) is changed to R235 (150k ohms). These changes give time constants of 0.1 second charge and one second discharge for all systems of operation.
 - (e) The BANDWIDTH switch SW201 is fitted with an additional section and has been re-wired to bring in the crystal filter on 1 kc/s in the third position of the switch.
 - (f) Certain leads in the IF Unit have been screened, to reduce hum pick-up.
 - (g) Increased smoothing is provided by replacing the 10H choke L303, by a 20H choke L304, and C307/8 ($4\ \mu\text{F}$ capacitors), to C314/5 ($8\ \mu\text{F}$ capacitors).
 - (h) To reduce hum, the following changes are incorporated:- Capacitors C316/7 ($0.02\ \mu\text{F}$ and $0.1\ \mu\text{F}$ respectively), are connected across L304, the screen of V302 is fed through R314 (4.7k ohms), and the heaters of V301/2 are earthed only in the IF Unit.
 - (j) The Note Filter, C302/L301 is removed, together with the associated BANDWIDTH switching. The anode load resistor of V301 (R302) is connected directly to the h.t. line.
 - (k) A replacement mains transformer A.P. 67763A (TR302), with a 'C' core, is fitted.
 - (l) A device is fitted to give a direct indication of the frequency band to which the receiver is switched.
 - (m) The trimming tools formerly supplied with the receiver were changed for the following reasons:-
 - (i) It was found that the existing tools were not suitable for lining up the crystal filter, due to the excessive metal.
 - (ii) In view of this, the tools were modified and simplified so that one tool, capable of trimming both the crystal filter and the ordinary IF trimmers, replaced two trimming tools previously supplied.

A.P. 57140C

5. The only differences between this pattern and A.P.57140B are those due to the adaptation of the receiver for common aerial working. They are as follows:-

Aerial Circuit Modifications Fig. 12 Chapter 3.

- (a) The aerial input is taken from Pins B and C of the aerial plug PL101. Pin A is earthed close to the plug and Pin D, previously connected to the secondary side of the input transformer TR101, via a small capacitor C101, to give a high impedance input, is no longer used. Separate co-axial leads are taken from Pins B and C of PL101 to contacts 1 and 2 of the aerial turret contact assembly. These contacts are also connected to the terminals of the micro-switch SWM (SW101 in B40D), which is operated by small conical cams fixed to the rear of the turret. The cams are placed so that when the turret contacts engage on any frequency range, the micro-switch contacts are open, and the aerial input circuits are included in series in the transmission lines. Whilst the turret is being switched from one range to another, the micro-switch is released and the contacts close, placing a short-circuit across the aerial input. When moving the turret from the operative position, the cams are arranged so that whichever way it moves, the micro-switch short-circuits the receiver input, before the tips of the pin contacts on the turret have been released by the fixed blade contacts. A connection between Pins A and B is thus maintained whilst switching from range to range.

Modifications to the Aerial Coil Compartments of the Turret

- (b) Circuit and layout diagrams of the three turret compartments concerned (Wavebands 1, 2 and 3) are shown in Figs. 1 and 2, Part 3, the additional components relative to the modifications are indicated by dotted lines. The input transformer primary circuits have been re-designed so that the conditions of common aerial working (as specified in B.R. 1615 Ch. 2) are maintained. The inductance of each primary winding is small enough to allow the π filter (formed by this winding and the additional capacitors for the common aerial working system) to have its cut-off frequency maintained above 30 Mc/s, when working into a 92 ohms load, thus avoiding attenuation of incoming signals over the frequency range of the receiver. The coupling between primary and secondary of TR101 is such as to ensure the matching conditions required, i.e. a standing wave ratio better than 0.4. In actual practice this means reducing the coupling, thus increasing the selectivity of the aerial circuit. This has the effect of increasing the noise factor on Ranges 1, 2 and 3. The increase in noise factor varies between 1 and 1.5 dB with a 92 ohms source. On Ranges 4 and 5, the primary inductance is so small that stray circuit capacity is sufficient to make the π filter.

Modified Earthing Arrangements Fig. 1

- (c) (i) These modifications achieve a reduction in coupling between the oscillator and aerial circuits in the RF turret. In the original patterns of the receiver, each coil compartment was insulated from the turret section to which it was secured. In the common aerial working receivers the aerial coil compartment is earthed to the

turret by the securing screws and a new earth terminal provided on the compartment, by replacing the paxolin spacer with a metal one. Additional earthing of the turret is provided by an earthing spider connected to a ring, which is in turn connected to the turret. A link is fitted between the oscillator and mixer sections of the turret, to maintain the relative potentials and reduce circulating currents.

- (ii) As a result of this additional earthing, the oscillator radiation has been reduced so that the interference experienced in the c.a.w. system is approximately at the same level as that experienced with a single aerial when the receiver aerials are separated by about 15 feet. With these single aerial systems, aerial separations of as little as four feet are not uncommon and this form of interference has not proved excessive. With the c.a.w. system there is the added advantage, that it is always possible to switch to the alternative aerial.

A.P. 5714OD

6. As previously stated in the introduction to the handbook, circuit references have been extensively changed in this pattern of the receiver. The mechanical and electrical differences between A.P.5714OD and 5714OC, can best be considered by dividing them into three groups as follows:-

- (a) Introduction of preferred type valves.
- (b) Introduction of facilities for the reception of Frequency Shift Keying.
- (c) Miscellaneous changes.

7. Dealing with the above groups in order:-

- (a) Changes due to the new valves

(i) Valves

Valve	B40/A/B/C CV No.	B40D CV No.	Operation
V101	CV327	CV4014	First RF
V102	CV303	CV454	Second RF
V103	CV302	CV2128	Mixer
V104	CV327	CV4014	Oscillator
V201/2/3	CV303	CV131	1st, 2nd and 3rd I.F.
V206	CV303	CV131	B.F.O.
V301	CV303	CV454	AF Amplifier
V302	CV304	CV2136	Output
V303	CV346 or CV1790	CV493	Rectifier
V304	CV287	-	Stabiliser
V304	-	CV493	Rectifier
V305	-	CV1832	Stabiliser

(A) AERIAL TURRET SECTION

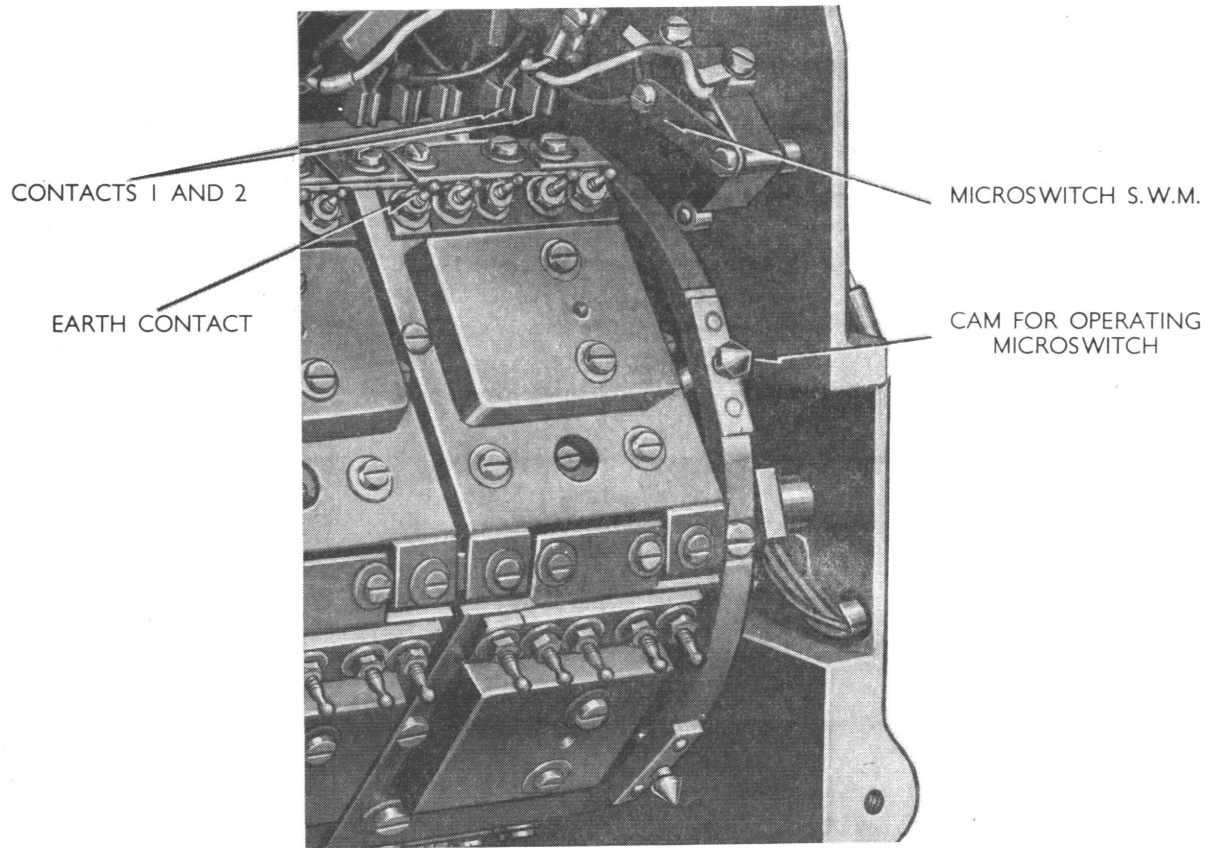

(B) OSCILLATOR AND R F. TURRET SECTIONS

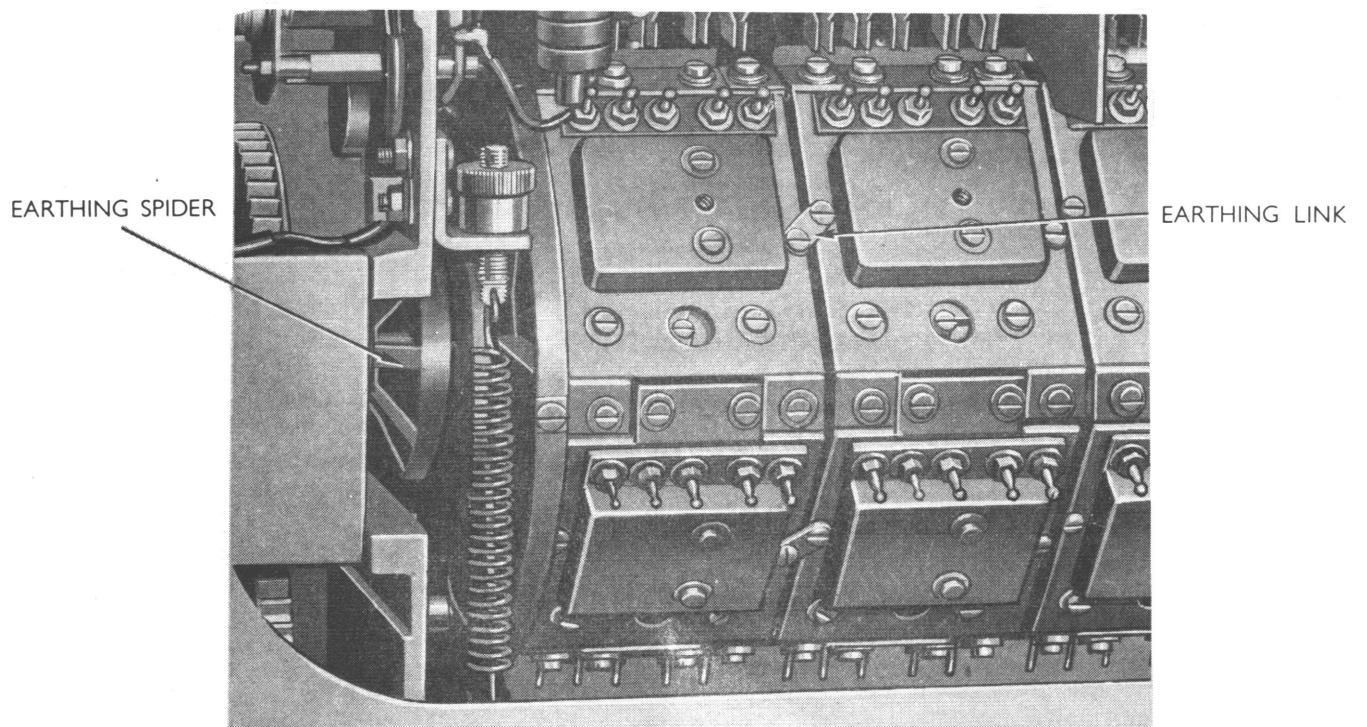

RECEIVER B40 A.P.57140 C/D
TURRET MODIFICATIONS

In the table given below, the valves underlined are those fitted so far, by the manufacturer. Eventually, the valves shown in the "Reliable" column will be used exclusively.

Meanwhile when a "Preferred" valve fails, it should be replaced by its "Reliable" equivalent, if this is available.

Ref.	Reliable	Preferred
V101	<u>CV4014</u>	CV138
V102	<u>CV4009</u>	<u>CV454</u>
V103	<u>CV2128</u>	
V104	<u>CV4014</u>	CV138
V201	<u>CV4015</u>	<u>CV131</u>
V202	CV4015	CV131
V203	CV4015	<u>CV131</u>
V204	CV4007	<u>CV140</u>
V205	CV4007	<u>CV140</u>
V206	CV4015	<u>CV131</u>
V301	CV4009	<u>CV454</u>
V302	CV4043	<u>CV2136</u>
V303	CV4005	<u>CV493</u>
V304	CV4005	<u>CV493</u>
V305	<u>CV1832</u>	

Underlined valves fitted by manufacturer.

(ii) Changes - Resistors

B4OC			B4OD			
Ref.	Value	Joint-Ser. Cat. No.	Ref.	Value	Joint-Ser. Cat. No.	Remarks
R115	220 ohms	Z221152	R121	68 ohms	Z221089	V102 Cathode
R116	56k ohms	Z223009	R123	82k ohms	Z223030	V103 Screen
R117	4.7k ohms	Z222089	R124	5.6k ohms	Z222101	V103 Anode
R119	560 ohms	Z221206	R125	390 ohms	Z221185	V103 Cathode
R203	560 ohms	Z221206	R203	470 ohms	Z221194	V201 Cathode
R207	560 ohms	Z221206	R207	470 ohms	Z221194	V202 Cathode
R212	220k ohms	Z223081	R212	270k ohms	Z223093	A.G.C. Delay
R213	15k ohms	Z222152	R213	12k ohms	Z222143	A.G.C. Delay
R236	680k ohms	Z223143	R236	270k ohms	Z223092	AF, A.G.C.
R237	680k ohms	Z223143	R237	1.2M ohms	Z223176	AF, A.G.C.
R302	68k ohms	Z223017	R302	82k ohms	Z223029	V301 Anode
R303	330k ohms	Z223101	R303	220k ohms	Z223080	V301 Screen
R304	820 ohms	Z221227	R304	220 ohms	Z221152	V301 Cathode
R308	120 ohms	Z221123	R308	470 ohms	Z221195	V302 Cathode
R310	680k ohms	Z223144 Deleted, CV1832 has no primary ignition electrode	R314	2.2k ohms	Z222048	V302 Screen
R314	4.7k ohms	Z222090	R315	470 ohms	Z221195	V302 Cathode

(iii) These component changes are all consequent upon the use of the new type valves and are necessary to ensure correct valve potentials, stage gain, and receiver characteristics.

(b) Changes due to the introduction of the FSK facility

(i) Two modifications have been made for this purpose:-

(1) The beat frequency oscillator has been made to function at two additional frequencies; these are marked "FSK WIDE -HIGH-" and "FSK WIDE -LOW-" on the SYSTEM Switch (Fig. 3 Ch. 1). The marking "FSK NARROW" has been added to the existing "C.W. -HIGH- and -LOW-" on the switch; however, the operation of this facility remains as before.

(2) A small variable capacitor, marked "OSC TRIM" on the front panel, has been added to the local oscillator circuit to give fine tuning.

(ii) Changes brought about by (1) above:-

C236 (470 pF), in the B40C is replaced by C236 (425 pF) and C250 (39 pF). C250 is a temperature compensating capacitor, hence greater stability of the b.f.o. is maintained for f.s.k. reception. The b.f.o. pitch coils in the B40C (L203 and L204) are no longer fitted; pitch control is effected in the B40D, by adjustment of the trimmers C239, C243, C247 (all 4 - 18 pF) and C245 (1 - 10 pF). The latter is shunted by C246 (3.3 pF) to provide the correct trimming range. The appropriate b.f.o. pitch is selected by the SYSTEM switch SW202. C248 (4.7 pF) is employed as a circuit balancing capacitor in the "WIDE HIGH" position to ensure that L202 is adjusted so as to fall within its frequency tolerance.

(c) Miscellaneous Changes

(i) To prevent excessive variation in image rejection figures, the capacitor changes listed below have been carried out.

B40C			B40D			
Ref.	Value	Joint-Ser. Cat. No.	Ref.	Value	Joint-Ser. Cat. No.	Location
C111	450 pF	Z125664	C186	120 pF	Z123926	Turret Compartment RF Band 5
			C121	330 pF	Z123941	
C115	450 pF	Z125664	C187	120 pF	Z123926	
			C140	330 pF	Z123941	
C124	450 pF	Z125664	C188	120 pF	Z123926	
			C176	330 pF	Z123941	

- (ii) The 450 pF capacitors in the B40C were 5% tolerance and were responsible for excessive variation in image rejection figures. In order to maintain 2% tolerance, two "preferred" type capacitors have been connected in parallel as indicated in the table, in lieu of the one capacitor previously used.
- (iii) In order to achieve correct trimming in the mixer circuit of Band 4, C114 (27 pF), in the B40C, has been changed to C136 (22 pF), in the B40D.
- (iv) In the ANTI-CROSS-MODULATION control circuit of the B40D, a crystal rectifier MR1 (CV448), and a resistor R130, have been added to prevent positive excursions of grid potential.
- (v) An additional resistor R240 (270 ohms), together with the switch contacts SW201k, ensure that the bias to V201 and V202 is adjusted to maintain constant gain in the IF amplifier when the bandwidth is changed.
- (vi) Band 3 Aerial Circuit (TR103)

Capacitor C189 (6.8 pF) added in parallel with C115.

Band 4 Aerial Circuit (TR104)

Capacitor C117 increased in value from 15 pF to 22 pF.

Band 5 Aerial Circuit (TR105)

Capacitor C120 increased in value from 47 pF to 56 pF.

Band 5 Oscillator Circuit (L105)

Capacitor C156 increased in value from 27 pF to 33 pF.

Note 1 These changes are to facilitate RF alignment and are included in receivers with serial numbers above 400.

Note 2 In B40C:- C115 is C109 Band 3
 C117 is C109 Band 4
 C120 is C110 Band 5
 C156 is C133a Band 5

PART 2

ALIGNMENT, TESTING, ADJUSTING

MAINTENANCE AND REPAIR

CHAPTER 5

DISMANTLING THE RECEIVER

LIST OF CONTENTS

	<u>Para.</u>
To remove the Receiver from its case	1
To remove the IF Unit	2
To remove the AF and Power Unit	3
RF Unit	4
Switch Wafers	5

CHAPTER 5

DISMANTLING THE RECEIVER

To remove the Receiver from its case Figs. 1, 2 and 3, Part 1, Chap. 1

1. Undo the two retaining nuts covering the front feet at the bottom of the front panel. Undo the two milled headed screws at the top corners of the front panel. Withdraw the connectors at the rear of the receiver. Pull the receiver upwards and forwards with the handles, it will then run out on two rollers situated at the bottom rear of the framework. It should be noted that the receiver weighs nearly 100 lb.

To remove the IF Unit Figs. 11, 13 and 15, Part 3

2. Remove the BANDWIDTH, SYSTEM, AF GAIN and LIMITER knobs. Withdraw the four inter-connecting plugs and sockets i.e. PL201 and PL103 (PL102, B4OD) to the RF Unit, plugs PL204/5 (PL203/4, B4OD) to the AF and Power Unit. Unscrew the two large retaining screws at the back of the IF Unit. Clear the dowel pins at the rear of the unit, it will then be possible to lift it clear.

To remove the AF and Power Unit Figs. 18, 21 and 23, Part 3

3. Remove the GAIN knob at the bottom right of the front panel. Withdraw the two large screws at the back of the unit. Withdraw plugs PL204/5, (PL203/4 B4OD). Pull back the unit and lift away from the panel.

RF Unit

4. All components can be reached on this unit without dismantling it from the receiver framework. If it should become necessary for the tuning mechanism to be removed, details are given in Chapter 9. The screws holding the mechanism in position are situated on the underside of the framework.

Switch Wafers

5. When replacing switch wafers on switches containing more than one of these items make sure that the locating notches are all pointing in the right direction.

CHAPTER 6ALIGNMENTLIST OF CONTENTS

	<u>Para.</u>
<u>General Instructions</u>	1-6
Introduction	1
Precautions	2
Trimming Tools	3
Component Identification	4
Test Equipment	5
Special Items	6
<u>The Alignment procedure in brief</u>	7-10
IF Alignment	7
B4OD b.f.o. Alignment	8
Crystal Filter Alignment	9
RF Alignment	10
<u>IF Alignment</u>	11-14
Test Equipment required	11
Special Items	12
The drill in outline	13
The drill in detail	14
<u>B.F.O. Alignment in B4OD receivers</u>	15-19
Introduction	15-16
Test Equipment required	17
The drill in outline	18
The drill in detail	19
<u>Crystal Filter Alignment</u>	20-23
Test Equipment required	20
Special Items	21
The drill in outline	22
The drill in detail	23
<u>Alternative Method of Crystal Filter Alignment</u>	24-29
Introduction	24-26
Test Equipment required	27
The drill in outline	28
The drill in detail	29

CHAPTER 6ALIGNMENTGENERAL INSTRUCTIONSIntroduction

1. Alignment will probably be necessary after replacement of major components in the RF and IF circuits, or if the receiver fails to reach the limits prescribed in performance measurements. However, before alignment is attempted, all other possible causes of poor sensitivity should be investigated. Alignment should be undertaken only by order of the Officer responsible for the maintenance of the equipment.

Precautions

2. When lining-up, the following precautions must be observed:-
 - (a) The receiver and test instruments must be connected individually to a common earth.
 - (b) All connecting leads must be as short as possible.
 - (c) Screened leads must be used to carry currents at RF or IF the screening being connected to the common earth.
 - (d) The receiver and test equipment must be allowed to warm through for at least 15 minutes before alignment is commenced, but a longer warming-up period for the receiver is sometimes advisable.

Trimming ToolsAP71479 TRIMMING TOOL

3. The appropriate trimming tool for the alignment procedure in hand should be selected from the Kit of Trimming Tools allowed for E.M.R. use. These trimming tools were at one time fitted in the receiver, but are now supplied as a kit. C 6

Component Identification

4. Where no ambiguity can arise, switches and controls have been referred to by name, but not identified by component numbers, in order to make the instructions more readable.

Test Equipment

5. The principal items required are:-

- (a) Test Oscillator

This should cover the frequency band of the receiver. The new Test Oscillator CT212 is particularly suitable, but G73 is also satisfactory. Its function is to provide a signal at a constant frequency and constant level for the duration of the alignment procedure.

The Modulation frequency employed is 1000 c/s for CT212, or 400 c/s for G73.

(b) Output Meter

The new Decibel Meter Portable No. 3 will provide this facility. Meanwhile, the output meter of the CT82 Noise Generator can be used, or a h. r. Avometer connected to read a.c. volts.

The function of the instrument is to show how the receiver output varies, due to adjustments during alignment.

(c) Variable frequency AF Oscillator

This is required to provide an accurate test oscillator setting when aligning the b.f.o. in the B4OD receiver. Ships fitted with this receiver will require dockyard or depot ship's assistance in this phase of alignment if they do not possess this test instrument. The Audio Oscillator G205 is the most suitable instrument at present in service.

(d) Oscilloscope Type 13A

This is needed for the same reason as given under (c) above. It is also used in conjunction with a frequency swept oscillator in a method of aligning the crystal filter, which gives more accurate results than the method which employs a signal generator and a micro-ammeter.

(e) Micro-ammeter

This indicates changes in second detector current due to adjustments made during crystal filter alignment. It is used to plot the crystal filter response curve when the test oscillator frequency is varied over the region around 500 kc/s.

Special Items

6. In order to save time when a receiver is in hand for alignment, certain special leads, connectors, etc., should be demanded and made up in good time beforehand.

The following special items, not already provided elsewhere, will be required:-

Item No.	Function	Item
1	To stop the b.f.o. valve oscillating. Connected between grid and chassis.	A 0.01 μ F capacitor, such as Z115552, with an A.P. W5845 crocodile clip joined to each end.
2	To permit an Output Meter to be connected to the receiver output (PL203) or PL202 (B4OD)	A Mk. 4 Socket Free, 6 way, Z560120. Connect about four feet of twin cable to Pins A and B. Prepare the other end of the twin cable for connection to an output meter. Early receivers with a 'W' type outlet socket, will require the corresponding item instead of the Mk. 4 socket.

Item No.	Function	Item
3	To enable second detector current to be read on a h.r. Avometer No. 8 A.P. 12945	A.P.60046 plug, fitted in socket SK.203, should be removed. Connect to it a three foot length of Uniradio 70 cable (AP.13870) or similar. Prepare the other end of the cable for connection to a h.r. Avometer No. 8
4	To reduce IF gain and so avoid overloading the receiver, when carrying out RF alignment.	An 0.01 μ F capacitor, such as Z115552 connected in series with a 68 ohm resistor. A crocodile clip A.P. W5845 is connected to each free end.

THE ALIGNMENT PROCEDURES IN BRIEF

IF Alignment

7. (a) The object of aligning the IF stages is to ensure:-
- (i) That each stage is tuned precisely to 500 kc/s (the intermediate frequency) so that the maximum voltage and the correct bandwidth are obtained at the output of the final IF amplifier.
 - (ii) That the b.f.o. is adjusted to the IF amplifier centre frequency of 500 kc/s and in the case of B40/A/B/C, to give a 1 kc/s beat note above or below this frequency. B40D is dealt with separately in para. 8.
- (b) It should not be necessary to re-align the IF stages after changing valves in the IF Unit. In receivers B40/A/B/C, the b.f.o. coil L202 may require readjustment if the b.f.o. valve is changed. To do this, the drill (given in para. 14) up to step 8(a) or (b) should be followed, omitting step (4) (i.e.) do NOT alter the trimming of the last IF transformer.
- (c) The adjustment of the dust-core trimmers should be carried out with the trimming tool provided in the E.M.R. trimming tool kit. The effect of an adjustment, as indicated in the output meter, should be noted when the trimming tool has been withdrawn from the trimmer.
- (d) As the various circuits are brought into tune, the output from the test oscillator should be altered as necessary to maintain the maximum wattmeter reading at a level of about 300 mW.

B40D B.F.O. Alignment

8. (a) The following b.f.o. frequencies need to be set up with an accuracy of ± 50 c/s in the WIDE position, or ∓ 20 c/s in the NARROW position of the SYSTEM switch. Receivers used for facsimile recording (MUFAX) ± 30 c/s in the WIDE position.

System Switch Position	Frequency	Remarks
FSK WIDE HIGH	2550 c/s	above 500 kc/s
FAX	1900 c/s	above 500 kc/s
FSK WIDE LOW	2550 c/s	below 500 kc/s
FAX	1900 c/s	below 500 kc/s
FSK NARROW HIGH	1000 c/s	above 500 kc/s
FSK NARROW LOW	1000 c/s	below 500 kc/s
TUNE	-	on 500 kc/s

- (b) This order of accuracy cannot be achieved by the normal "beat" method. An oscilloscope is therefore employed. The necessary frequency is fed into the oscilloscope from an audio frequency oscillator, and the audio output frequency of the receiver is adjusted by means of the b.f.o. trimming capacitors so as to "match" the audio oscillator frequency, thus producing an ellipse in the c.r.t.
- (c) An RF signal is fed in at the grid of the 3rd IF valve. As the signal generator cannot be tuned to the receiver CAL signal with sufficient accuracy by the "zero beat" method, the signal generator is tuned to 499.5 kc/s (500 c/s below the receiver IF centre frequency), and "matched" in the oscilloscope for accuracy with a 500 c/s signal from the audio oscillator. This has to be taken into account when adjusting the audio oscillator, whose output frequencies are given in the table below:-

B4OD System Switch Position	Sig. Gen. Frequency	B.F.O. Adjusted for:-	Resultant AF Output	AF Oscillator Frequency
WIDE HIGH	499.5 kc/s	500 kc/s + 2550 c/s	3050 c/s	3050 c/s
WIDE LOW	499.5 "	500 kc/s - 2550 c/s	2050 c/s	2050 c/s
NARROW HIGH	499.5 "	500 kc/s + 1000 c/s	1500 c/s	1500 c/s
NARROW LOW	499.5 "	500 kc/s - 1000 c/s	500 c/s	500 c/s
TUNE	499.5 "	500 kc/s	500 c/s	500 c/s

Crystal Filter Alignment

9. (a) The object of aligning the crystal filter is to ensure that it possesses the correct response curve and bandwidth, with its centre frequency at 500 kc/s.
- (b) If the filter is very badly out of adjustment, it is recommended that realignment should not normally be undertaken in seagoing ships, but that assistance be sought from the dockyard or depot ship, unless the crystal filter facility is considered to be of very great immediate importance. A great deal of time, patience and care is necessary if the correct response curve is to be achieved.

RF Alignment

10. In general, this ensures:-

- (a) Maximum voltage output from the RF section, optimum selectivity, and the correct bandwidth, over the frequency band covered by the receiver, by bringing all three tuned circuits into alignment. This is done by "trimming" for maximum receiver output at "trimming points" near the top and bottom of each waveband.
- (b) Correct indication of frequency (including calibration points) on the tuning dial, by adjustment of the local oscillator trimming components. It is also necessary to ensure that the local oscillator is operating at 500 kc/s ABOVE the frequency of the incoming signal. This is checked by setting both test oscillator and receiver to a given frequency, then increasing the test oscillator frequency by 1 Mc/s. The test oscillator signal is now 500 kc/s above the receiver local oscillator frequency, and thus produces an IF signal which should be heard, although at greatly reduced strength.

IF ALIGNMENTTest Equipment Required

11.

Test Equipment Description	Type	Admiralty Pattern
Test Oscillator or Signal Generator covering 500 kc/s modulated 30% at 400 or 1000 c/s	CT212 G73 CT218 Marconi	ZD.00784 W2508 10S/16780 54704/A
Output Meter	Decibel Meter Portable No. 3 Output Meter of Noise Generator CT82. TF340	ZD.00022 67166 54708
Connector } Adaptor }	- -	60861 60865

⌘ These items are required for CT212 Test Oscillator, and are obtained from the A.P.60875/A Box of Flexible connections for CT82 Noise Generator.

Special Items

12. The following special items will be required:-

Items No. 1 and 2, shown in para. 6 under "General Instructions".

13. The drill in Outline

Steps

- | | |
|--|-------|
| (1) Remove the receiver from its case, remove the side panel from the RF Stages, connect up the test equipment, and switch on. Allow to warm through for 1 hour. | 1-3 |
| (2) Line up last IF stage approximately. | 4-5 |
| (3) Adjust the b.f.o. roughly by the Test Oscillator | 6-7 |
| (4) Alignment of b.f.o. (B4O/A) | 8(a) |
| (5) Alignment of b.f.o. (B4OB/C) | 8(b) |
| Reference to alignment of b.f.o. (B4OD) | 8(c) |
| Line up accurately the last IF stage | 9-10 |
| (6) Line-up the remaining IF stages | 11-14 |
| (7) Final "touch-up" | 15-16 |

Paras.

- | | |
|---|-------|
| (8) Complete instructions, with test equipment list, and connections for alignment of B4OD b.f.o. | 15-19 |
|---|-------|

FIG. 1

I F ALIGNMENT CONNECTION DIAGRAMS

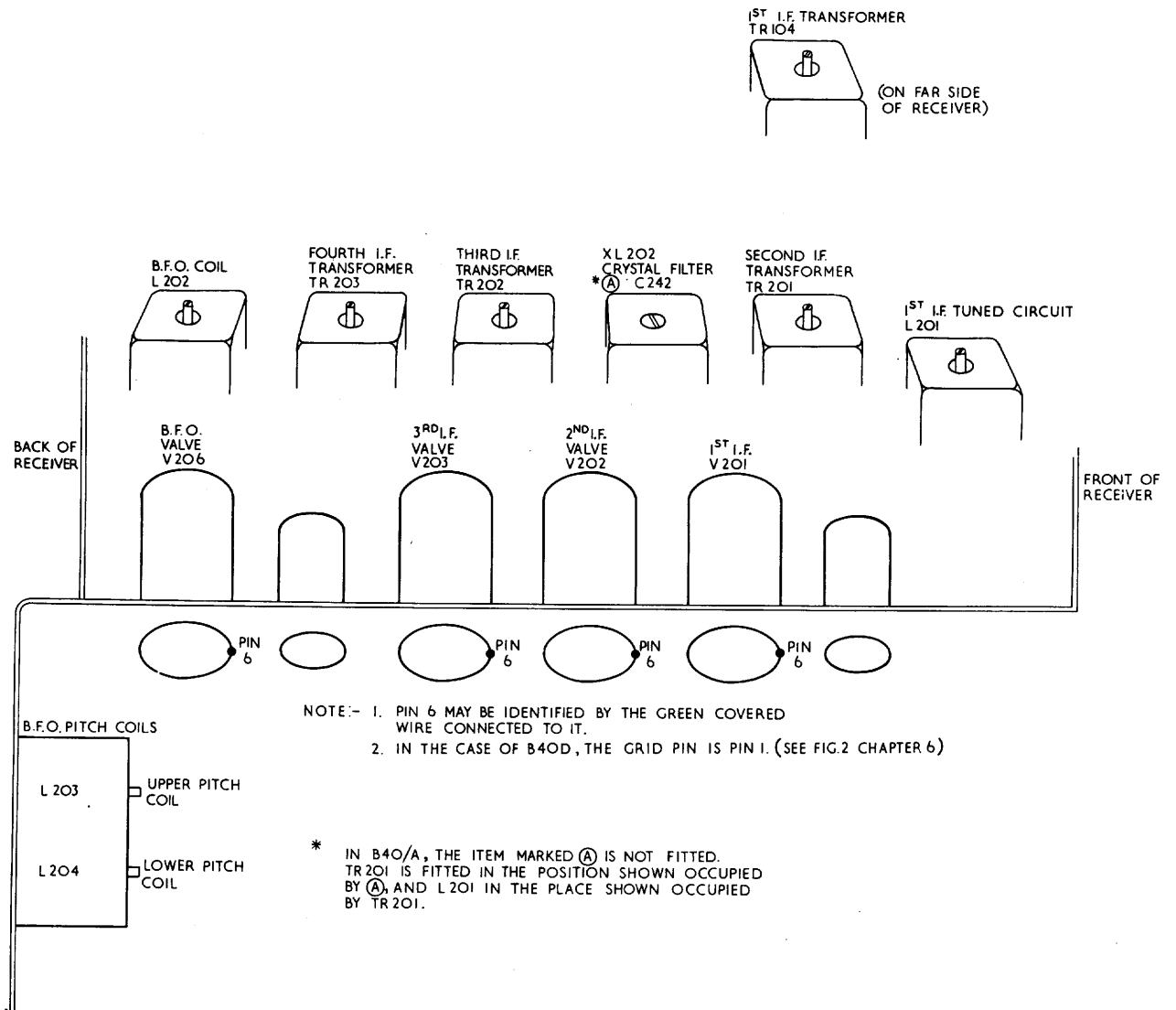

RECEIVER B40/A/B/C

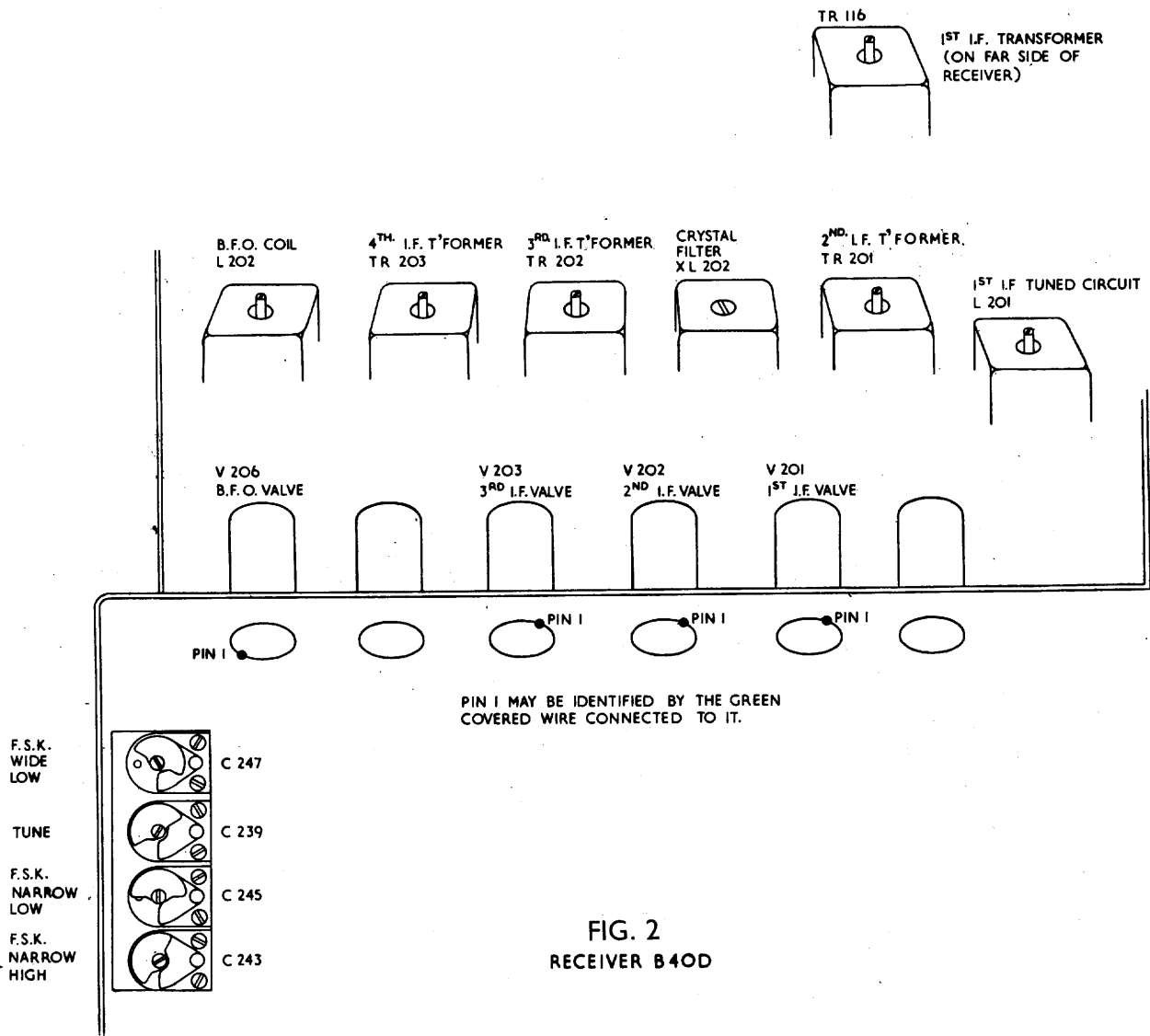

FIG. 2
RECEIVER B40D

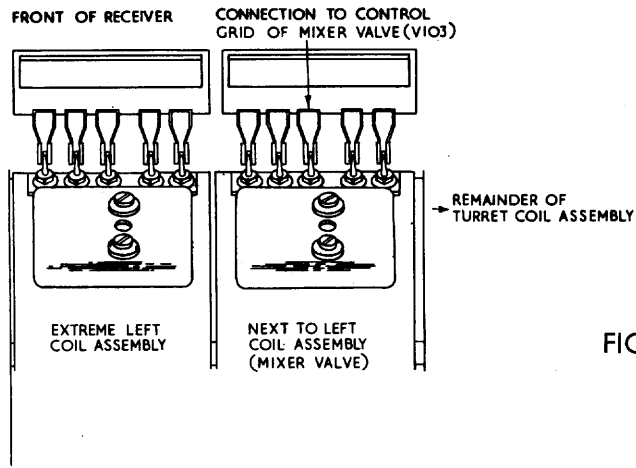
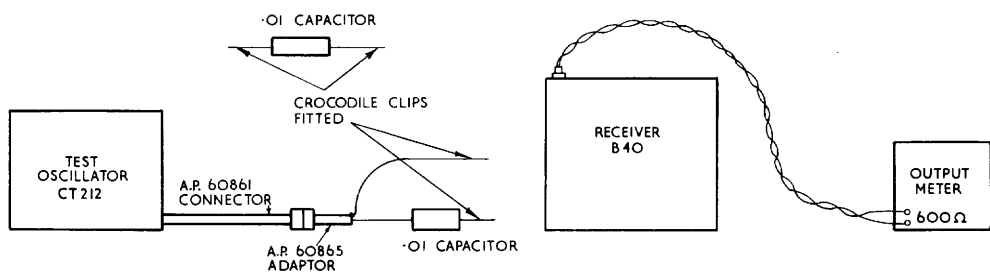

FIG. 3



TEST EQUIPMENT CONNECTION DIAGRAM

FIG. 4

The Drill in Detail

14.

STEPACTION

- 1 Remove the receiver from its case, and take off the side panel covering part of the RF Unit. Connect test equipment as shown, and allow equipment to warm through for at least 1 hour. N.B. The SYSTEM switch should be to C.W., so that the b.f.o. will warm through.
- 2
- (1) Position receiver controls as follows:-
 - (2) ANTI-CROSS-MOD control fully CLOCKWISE.
 - (3) CRYSTAL switch to "ON". There should be no crystal in position. This renders the local oscillator inoperative without altering the load on the h.t. line.
 - (4) LIMITER switch to "OFF".
 - (5) OUTPUT switch (at back of receiver) toggle towards back of receiver.
 - (6) L.S. switch to "ON".
 - (7) A.F. GAIN control fully clockwise. OSC. TRIM to zero, i.e. midway between limits (B4OD only).
 - (8) GAIN control fully clockwise.
 - (9) BAND switch to BAND 1, tuning dial to about 0.67 Mc/s.

	B4O/A	B4OB/C/D
Band-width Switch	Narrow	3 kc/s
System Switch	Manual	R/T
A.G.C. Switch	-	OFF

- 3 Adjust the test equipment as follows:-

Test oscillator

- (1) Output about 0.1 volt, modulation depth 30% modulation 1000 c/s.

- (2) Output frequency 500 kc/s.
- (3) Output connected via the 0.01 μF capacitor to the grid of the 3rd IF valve. (Identify by Figs. 1 or 2).
- (4) 0.01 μF capacitor. Connect between the grid of the b.f.o. valve and chassis. (See Fig. 1). (B40/A only).
- (5) Output meter. Set to 600 ohms input impedance and to read 500 mW.

STEP

ACTION

- 4 Adjust the trimming controls (screwed rods) at the top and bottom of the final IF transformer (TR.203) for maximum reading in the output meter. Adjust the output of the Test Oscillator as necessary for a convenient output meter reading.
- 5 Switch off the test oscillator modulation. Unclip the 0.01 μF capacitor between the grid of the b.f.o. valve and chassis (B40/A).
- 6 SYSTEM switch to CAL. Adjust the test oscillator tuning for zero output meter reading at zero beat. This ensures that the test oscillator is accurately tuned to 500 kc/s.
- 7 SYSTEM switch B40/A to MANUAL (B40B/C - to TUNE). Adjust the trimming control of b.f.o. coil L.202 for zero beat, indicated by zero reading in the output meter.

8(a) B40/A Receivers only

NOTE To prevent the a.g.c. system being brought into operation in 8(a) (1) and (2) below, the test oscillator output must not exceed 100 mV.

- (1) SYSTEM switch to HIGH and the BANDWIDTH switch to NOTE FILTER. Adjust the b.f.o. coil L.202 for maximum output meter reading.
- (2) SYSTEM switch to LOW. Adjust the upper b.f.o. pitch coil L203 for maximum output.
- (3) SYSTEM switch to MANUAL and the BANDWIDTH switch to NARROW. Adjust the lower b.f.o. pitch coil L.204 for zero beat, i.e. for zero output meter reading.
- (4) SYSTEM SWITCH to CAL. and check that the test oscillator is still on frequency, i.e. zero output meter reading. If not, readjust the test oscillator, and repeat the drill from 7 onwards.

8(b) B40B/C Receivers only

NOTE Due to the absence of the 1 kc/s filter (which is fitted only in B40/A receivers) it is not possible to use the selectivity of the filter as a means of obtaining a 1 kc/s note. It is therefore necessary to modulate the 500 kc/s input at 1000 cycles, and compare the pitch of the b.f.o. note with the pitch of the 1 kc/s modulation.

- (1) SYSTEM switch to HIGH. Test oscillator modulation to 1000 c/s. N.B. If a CT212 test oscillator is not available, it will be necessary to inject 1000 c/s. from an AF oscillator such as G.205, at the resistor R223. (See details given in Part 3 Fig. 13). The output level of the AF oscillator should be adjusted to give a comfortably audible note in the monitor loudspeaker. If a test oscillator other than CT212 is used, the RF output should be unmodulated, and tuned to 500 kc/s, checked against the B4O calibrator.
 - (2) Adjust L202 by means of the trimmer at the top of the b.f.o. coil can, until the b.f.o. note obtained with the SYSTEM switch to HIGH and test oscillator unmodulated corresponds with the b.f.o. note obtained with SYSTEM switch to R/T and the test oscillator modulated at 1000 c/s.
 - (3) SYSTEM switch to LOW. Adjust the upper b.f.o. pitch coil L205 until there is no change of note when the SYSTEM switch is set to HIGH.
 - (4) SYSTEM switch to TUNE. Switch off modulation (or disconnect the AF oscillator). Adjust the lower pitch coil L204 for zero reading in the output meter.
- N.B. The tuning is very flat.
- (5) SYSTEM switch to CAL. Check that the test oscillator is still on frequency (zero beat with CAL. signal). If not, correct the test oscillator frequency and repeat steps 8(b)(1) to (5).

STEPACTION

8(c)

B4OD receivers only

As the drill for the b.f.o. alignment of the B4OD is long and complicated, it is given separately after this drill (6.15 to 19).

9

B4O/A SYSTEM switch to MANUAL. Clip the 0.01 μ F capacitor between the grid of the b.f.o. valve and chassis. B4OB/C/D SYSTEM switch to R/T. Switch ON the test oscillator modulation.

10

Adjust the top and bottom IF Trimmers of the fourth IF transformer (TR.203) for maximum output meter reading. (See Fig. 2 for component positions.)

11

Connect the test oscillator output to the grid of the 2nd IF valve. Adjust the top and bottom IF trimmers of the third IF transformer (TR.202) for maximum output meter reading.

12

Connect the test oscillator output to the grid of the 1st IF valve. Adjust the top and bottom trimmers of the second IF transformer (TR.201) for maximum output meter reading.

STEPACTION

- 13 Connect the test oscillator to the grid of the mixer valve, i.e. to the stationary turret coil contact as shown in Fig. 3. Tune the first IF transformer (TR104/116) and the 1st IF tuned circuit (L201) for maximum output meter reading.
- 14 SYSTEM switch to CAL., switch off test oscillator modulation, unclip capacitor from b.f.o. grid. Check that the test oscillator is still on frequency. If not, readjust the test oscillator and repeat the drill from 12 onwards.
- 15 SYSTEM switch to MANUAL, switch on test oscillator modulation, re-connect capacitor to b.f.o. grid. Re-check adjustment of TR104, or TR116 (B4OD), L201, TR201, TR202 and TR203 in that order for maximum output meter reading.
- 16 Disconnect test oscillator and output meter. Unclip capacitor from grid of b.f.o. valve.

B.F.O. ALIGNMENT IN B4OD RECEIVERS

(Step 8(c) in the IF Alignment, Para. 14)

Introduction

15. Unless ships are provided with an AF variable frequency oscillator, it will not be possible for sea-going personnel to align the b.f.o. circuits of the B4OD receiver. If these circuits are in need of alignment, assistance should be sought in the normal manner from the depot ship or the dockyard. For B4OD Receivers used in conjunction with MUFAX Recorders the alternative frequencies quoted in the drill must be used. Such receivers are clearly labelled to indicate they are used for FAX.
16. For dockyards and those ships having access to an AF oscillator; the procedure is as follows:-

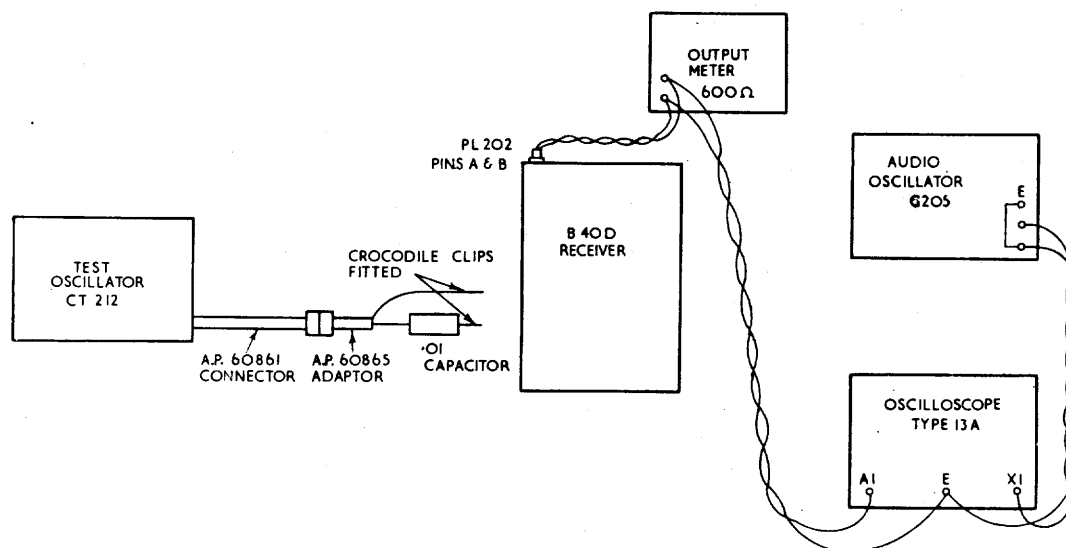

B.F.O. ALIGNMENT (B 4OD)
TEST EQUIPMENT CONNECTION DIAGRAM

FIG. 5

Test Equipment required

17.

Test Equipment description	Type	Admiralty Pattern
Test Oscillator or Signal Generator covering 500 kc/s	CT212 CT218 Marconi	ZD00784 10S/16780 54704A
Audio Frequency Oscillator covering 0-5000 cycles	G205	W7252
Oscilloscope	Oscilloscope Type 13A	10S/831
Output Meter	Decibel Meter Portable No. 3 TF340	ZD00022 54708

NOTE See also Fig. 2 for positions and identities of components.

The Drill in Outline

18.

STEP

Carry out the drill for IF alignment up to and including step (6).	1
Connect the test equipment to the receiver.	2
Set up the FSK WIDE HIGH position (or FAX).	3-6
Set up the FSK WIDE LOW position (or FAX).	7-8
Set up the FSK NARROW HIGH position.	9-10
Set up the FSK NARROW LOW position.	11-12
Set up the TUNE trimmer.	13-14
Re-check the signal generator setting.	15
Re-check all FSK settings and TUNE setting.	16

The Drill in Detail

19.

STEPACTION

1	Follow the procedure for IF alignment up to and including Step 6.
---	---

STEPACTION

- 2 Make the following additional receiver and test equipment connections and adjustments (Fig. 5):-
- (1) Audio oscillator. Adjust to 500 c/s per second.
Output to X1 and E of oscilloscope.
One side of output to E.
 - (2) Oscilloscope
A1 to output meter
X1 to audio oscillator
CAL. markers - OFF
Trig. sync. - EXT.
Velocity range - Xx1
Y plate selector - A1A2

Produce a "square" picture by suitable adjustment of oscilloscope A1 gain and audio oscillator gain.
 - (3) Receiver
A.G.C. to ON
Loudspeaker switch to ON.
SYSTEM switch to CAL.
 - (4) Signal generator
Adjust to a frequency several kc/s below 500 kc/s. Connect output via the 0.01 μ F capacitor to the grid of the mixer valve. (See Fig. 3 under "I.F. Alignment" for connection identity.)
- 3 Increase the signal generator frequency slowly to 499.5 kc/s. An ellipse will appear on the oscilloscope c.r.t.
- 4 Adjust the audio oscillator to 3050 cycles (2,400 c/s for MUFAX).
- 5 Receiver SYSTEM switch to FSK WIDE HIGH.
- 6 Adjust the b.f.o. coil tuning slug (L202) until an ellipse is observed in the oscilloscope c.r.t.
- NOTE The frequency required is 502.55 kc/s, not 496.45 kc/s (501.9 kc/s not 497.1 kc/s for MUFAX). A check that the higher of the two frequencies is tuned can be made by screwing the tuning slug out of the coil slightly; this increases the audio output frequency.
- 7 Audio oscillator to 2050 c/s (MUFAX - 1400 c/s).
SYSTEM switch to FSK WIDE LOW.

- | <u>STEP</u> | <u>ACTION</u> |
|-------------|--|
| 8 | Adjust the FSK WIDE LOW trimmer (C247) for an ellipse in the c.r.t. (C247 can be identified from Fig. 2.) Should two different settings of C247 produce an ellipse, set to the tuning position where the trimming capacitor is most fully meshed, i.e. greatest capacitance. |
| 9 | Audio oscillator to 1500 cycles.

SYSTEM switch to FSK NARROW HIGH. |
| 10 | Adjust the FSK NARROW HIGH trimmer (C243) for an ellipse in the c.r.t. Should two different settings of C243 produce an ellipse, set the trimmer to the position of least capacitance. |
| 11 | Audio oscillator to 500 c/s.

SYSTEM switch to FSK NARROW LOW. |
| 12 | Adjust the FSK NARROW LOW trimmer (C245) for an ellipse in the c.r.t. If there are two settings which produce an ellipse, use the setting where the trimmer has greatest capacitance. |
| 13 | SYSTEM switch to TUNE. |
| 14 | Adjust TUNE trimmer (C239) for an ellipse in the c.r.t. If there are two settings which produce an ellipse, use the setting where the trimmer has least capacitance. |
| 15 | Check frequency setting as follows:-

SYSTEM switch to CAL
Audio oscillator to 500 c/s
Signal generator to 499.5 kc/s

An ellipse should be seen on the c.r.t. If necessary vary the signal generator tuning slightly until the ellipse appears, but do <u>NOT</u> tune to 500.5 kc/s, at which another ellipse will appear. |
| 16 | Check that an ellipse appears in the c.r.t. when the following adjustments are set. |

RECEIVER SYSTEM SWITCH	AF OSCILLATOR OUTPUT
FSK WIDE HIGH	3050 c/s \pm 50 c/s
FAX	2400 " " 30 "
FSK WIDE LOW	2050 " " 50 "
FAX	1400 " " 30 "
FSK NARROW HIGH	1500 " " 20 "
" " LOW	500 " " " "
TUNE	500 " " " "

To complete the IF alignment return to Step 9 in paragraph 14.

CRYSTAL FILTER ALIGNMENT

(B40B/C/D only)

NOTE This procedure does not apply to the receivers B40/A which are not fitted with a crystal filter.

Test Equipment required

20.

Instrument	Title	Admiralty Pattern
Signal Generator or Test Oscillator covering 500 kc/s	CT212 CT218 Marconi G73	ZD00784 10S/16780 54704/A W.2508
Meter reading 250 micro-amps full scale deflection	H.R. Avometer 8S or 8SX Microammeter	12945 54148
Connector } Adaptor }	- -	60861 60865

* These items are required for CT212 Test Oscillator, and are obtained from the A.P. 60875 Box of Flexible Connections for CT82 Noise Generator.

Special Items

21. The following special items are required:-

Items 1 and 3 shown in para. 6 under "General Instructions".

NOTE The IF stages must be accurately aligned before the crystal filter is aligned.

The drill in Outline

22.	<u>STEPS</u>
Remove receiver from case. Connect up test equipment. Switch on.	1-3
Set crystal filter frequency exactly in centre of IF passband i.e. to 500 kc/s.	4-5
Obtain adjustments, and mark the test oscillator incremental tuning control at two points, one 1 kc/s above and one 1 kc/s below, the centre frequency of 500 kc/s.	6-10
Obtain smooth crystal filter response curve, symmetrical and with sharp cut-off.	11-12
Final "touch-up".	13-14.

NOTE:- REFER TO FIGS.1-4 FOR FURTHER CONNECTION DETAILS.

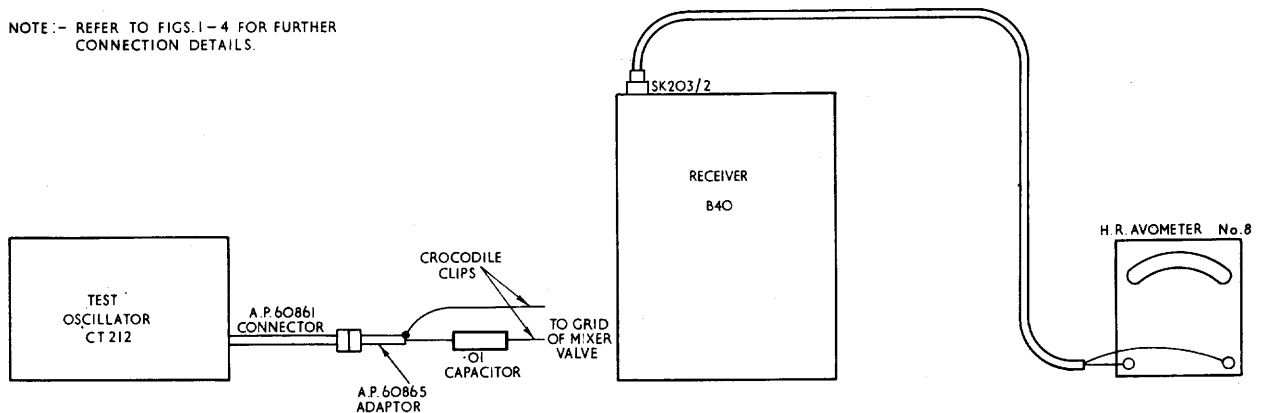

FIG. 6(a)
TEST EQUIPMENT CONNECTION DIAGRAM
CRYSTAL FILTER ALIGNMENT

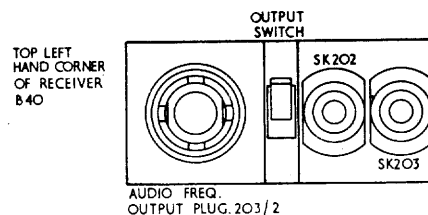

FIG. 6(b)

The Drill in Detail

23.

STEP

ACTION

1 With the receiver out of its case and the side panel removed, switch on the receiver and test oscillator and allow 15 minutes to warm through.

2 Receiver controls as follows:-

CRYSTAL switch to ON, with crystal removed.

BANDWIDTH switch to 1 kc/s.

SYSTEM switch to CAL.

Tune to 0.67 Mc/s.

Output switch at the back of the receiver, toggle towards front of receiver.

A.G.C. switch to OFF.

LIMITER switch to OFF.

A.F. GAIN control fully clockwise (RV.224)

GAIN control fully clockwise (RV.305/309)

Monitor L.S. switch to "ON"

3 Adjust the test equipment as follows:-

(1) Test oscillator

Output not exceeding 50 microvolts.

Output frequency 500 kc/s

C.W.

Output connected via A.P.60861 connector, A.P.60865 adaptor, and a 0.01 μ F capacitor to the grid of the mixer valve, i.e. to the stationary turret coil contact as shown in Fig. (3) under IF alignment.

(2) Avometer. Connect to the made-up lead, (6.6 Item 3) with the plug inserted in SK203 and the other end joined to the Avometer, central conductor of the coaxial cable to negative of Avometer.

N.B. This enables second detector current to be read on the Avometer.

Set the Avometer to read d.c. microamps, 250 μ A range.

- | <u>STEP</u> | <u>ACTION</u> |
|-------------|---|
| 4 | Test oscillator - note reading on incremental scale. Tune to 500 kc/s and adjust for zero beat as heard in receiver telephones. |
| 5 | SYSTEM switch to R/T. Adjust C242 at the top of the crystal filter can (shown in Fig. 1 under IF alignment) for maximum reading in the Avometer. The oscillator output should be adjusted to give an Avometer reading of approximately 60 micro-amps.

SYSTEM switch to CAL. Check that test oscillator is still on 500 kc/s (zero beat note, using telephones for greater accuracy.) |
| 6 | SYSTEM switch to R/T. Test oscillator from c.w. output to 1000 c/s modulation output. Listen to the 1000 c/s note. |
| 7 | SYSTEM SWITCH to TUNE. Test oscillator to c.w. By means of the incremental tuning control on the test oscillator, slowly increase the frequency of the test oscillator. A low pitched note, due to the action of the b.f.o., will be heard. |
| 8 | Increase the test oscillator frequency still further until the b.f.o. beat note is equal in pitch to the 1 kc/s modulation. Mark the incremental tuning control to indicate the setting at which this occurs. |
| 9 | Rotate the incremental tuning control back to its 500 kc/s position, then slowly decrease the test oscillator frequency until the b.f.o. beat note and the modulation note are equal in pitch. Mark the incremental tuning control to indicate the setting at which this occurs.

The incremental tuning control will now be marked at two points, one 1 kc/s above and the other 1 kc/s below the 500 kc/s position. |
| 10 | Test oscillator to c.w. output, incremental scale to zero. Receiver SYSTEM switch to CAL. Check that test oscillator is still at 500 kc/s. If not, repeat the drill from step 6 onwards. |
| 11 | SYSTEM switch to R/T. Set the incremental tuning control to the mark 1 kc/s above 500 kc/s. Carefully increase the test oscillator output so that 40 microamps is indicated in the Avometer. Adjust C240 (side of crystal filter can) for <u>minimum</u> reading in the Avometer. |
| 12 | Slowly sweep the incremental tuning control between the two marks, above and below the centre frequency, at the same time noting the manner in which the reading in the Avometer indicates the response curve of the crystal filter. The current reading in the Avometer should follow the curve shown overleaf. |

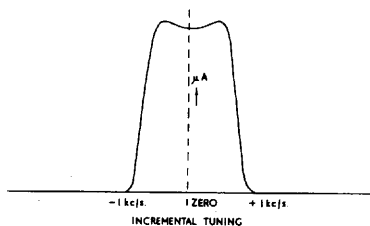

RESPONSE - CRYSTAL FILTER FIG. 7

STEP

ACTION

- 13 Make very small adjustments to C240, if necessary, to obtain sharp cut-off with symmetrical response.
- 14 SYSTEM switch to CAL., make a final check that the test oscillator is at 500 kc/s.

ALTERNATIVE METHOD OF CRYSTAL FILTER ALIGNMENT

Introduction

- 24. It has been found that a more positive result in crystal filter alignment can be achieved by the use of a ganging oscillator and a cathode ray oscilloscope.
- 25. Since this test equipment is not universally available, the method of alignment already described is considered to be the standard method. For the benefit of dockyards and ships which may possess the necessary equipment, however, the alternative method, using a ganging oscillator, is described below.
- 26. Crystal filter alignment should not be undertaken unless the IF stages are correctly aligned.

Test Equipment Required

27.

Test Equipment Description	Type	Admiralty Pattern
Ganging Oscillator covering 500 kc/s, sweep speed down to 5 c/s if possible	Cossor Model 343	54707
Cathode Ray Oscilloscope, with amplifier linear down to 5 c/s if possible	13A Cossor	10S/831 W3336A

WARNING If the sweep rate of the ganging oscillator is higher than approximately 10 cycles, the crystal filter response curve picture will be distorted due to "ringing" in the high-Q crystal filter circuit.

Conversely, if the sweep rate is much lower than 10 cycles, the crystal filter response curve picture may be distorted due to non-linearity of the c.r.t. amplifier.

These points must be remembered during alignment

The drill in OutlineSTEPS

- | | | |
|-----|--|------|
| 28. | Connect up, set up and switch on test equipment and receiver. | 1-5 |
| | Tune ganging oscillator until a response curve is seen on the c.r.o. | 6 |
| | Adjust the trimming controls until the required shape of response curve is obtained. | 7-10 |

The connection to the mixer grid can be identified by reference to Fig. 3 under IF Alignment. The connections shown are used with the Cossor Ganging Oscillator and Oscilloscope 13A.

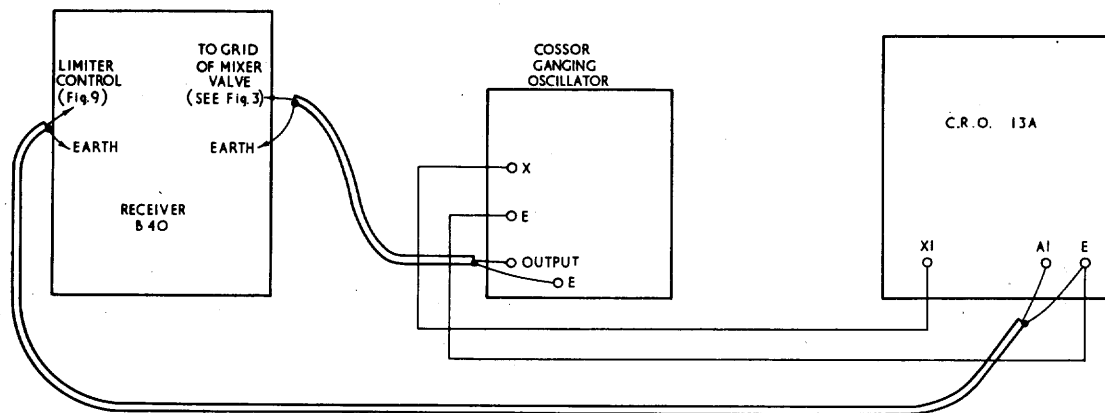

NOTE:- CONNECTIONS USED WITH COSSOR GANGING OSCILLATOR & 13A OSCILLOSCOPE.

FIG. 8

TEST EQUIPMENT CONNECTION DIAGRAM
CRYSTAL FILTER ALIGNMENT (ALTERNATIVE METHOD)

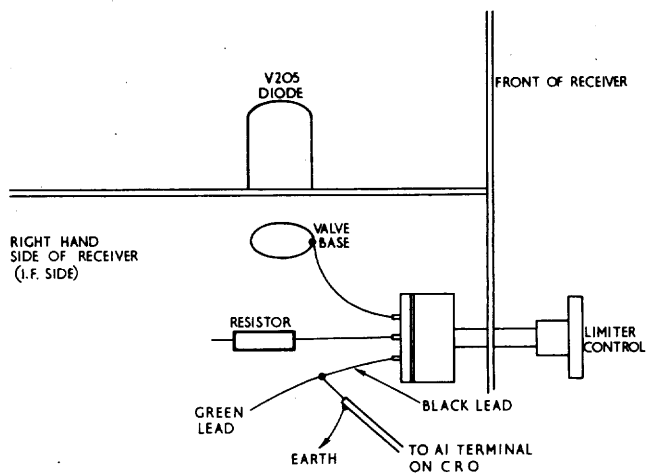

CONNECTION TO RECEIVER FROM CRO
FIG. 9

The Drill in Detail

29.

STEPACTION

- 1 Remove the receiver from its case. Remove the RF Unit side-panel.
- 2 Position the controls on the receiver as follows:-
 - (1) CRYSTAL switch to "ON", with crystal removed.
 - (2) BANDWIDTH switch to 3 kc/s.
 - (3) SYSTEM switch to R/T.
 - (4) WAVEBAND switch to BAND 1, tuning dial to about 0.67 Mc/s.
 - (5) Output switch at back of receiver, towards front of receiver.
 - (6) A.G.C. switch to OFF.
 - (7) LIMITER switch to OFF.
 - (8) A.F. GAIN control fully clockwise (RV.224).
 - (9) GAIN control fully clockwise (RV.305/309).
 - (10) Monitor L.S. switch to "OFF".
- 3 Frequency swept oscillator controls as follows:-
(Cossor Ganging Oscillator for example)
 - (1) Modulation control to frequency modulation.
 - (2) Adjust frequency to 500 kc/s approximately.
 - (3) Bandwidth switch to 20 kc/s.
- 4 Cathode ray oscilloscope controls as follows:-
(Type 13A Oscilloscope for example - important controls only are mentioned.)
 - (1) Trig. sync. - external.
 - (2) Velocity range - 10 c/s.
 - (3) Fine velocity - as low as convenient (not more than 10 sweeps per sec.)
 - (4) Probe selector to OFF.
 - (5) Y plate selector to A1A2.
 - (6) CAL. markers to OFF.

STEP

ACTION

- 5 Switch on equipment and allow to warm through.
- 6 Rotate the ganging oscillator tuning dial until the response curve is seen in the oscilloscope. If the IF stages have been accurately aligned, the peak of the curve will be at 500 kc/s. As it has been aligned against its own crystal, the IF calibration will probably be more accurate than the calibration of the frequency scale on the ganging oscillator. The latter should therefore be disregarded.

The shape of the response curve should be as shown in (a) Fig. 10.

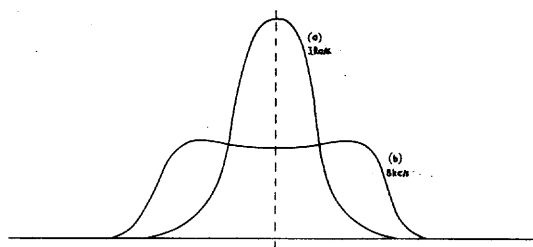

I.F. RESPONSE CURVES FIG. 10

NOTE If the ganging oscillator has a bandwidth control, the width of the curve can be adjusted.

On switching the receiver BANDWIDTH control to WIDE (or 8 kc/s), the curve should resemble (b) above.

If the curves are distorted, then the IF stages need adjustment, and the complete IF alignment should be carried out.

- 7 Receiver BANDWIDTH switch to 1 kc/s. If possible reduce the Ganging oscillator BANDWIDTH to 10 kc/s.

The response curve obtained will depend upon the crystal filter settings. One of the following curves should be seen.

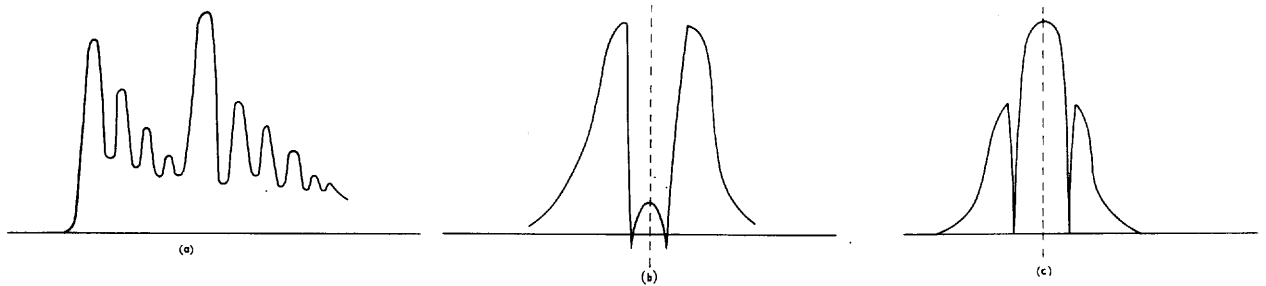

FIG. 11

STEPACTION

- 8 Adjustment of the "top" trimmer will normally produce a picture similar to Fig. 11(b) or (c), and further adjustment should be made to obtain equal peaks of maximum possible height.
- 9 Adjustment of the "side" trimmer has the effect of lifting the central hollow in sketch Fig. 11 (b), or of reducing the two side peaks in Fig. 11 (c).
- Adjustment should continue until a curve similar to Fig. 12(d) below is achieved.

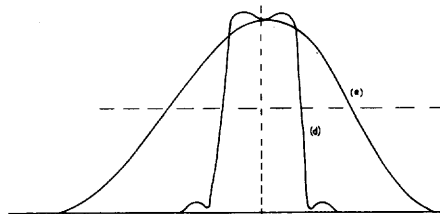

FIG. 12

STEPACTION

- 10 On switching receiver BANDWIDTH switch between 1 kc/s and 3 kc/s, the two curves Fig. 12 (d) and (e) should appear in turn. It will be observed that the bandwidth of the 1 kc/s curve is approximately half the bandwidth of the 3 kc/s curve at half maximum amplitude, i.e. 6 dB down from maximum.

RF ALIGNMENT

NOTE The IF Unit of the receiver must be correctly aligned before RF alignment is commenced.

Test Equipment required

30.

Test Equipment Description	Type	Admiralty Pattern No.
Test Oscillator or Signal Generator covering 600 kc/s to 30 Mc/s	CT212 CT218 Marconi G73	ZD00784 10S/16780 54704/A W2508
Meter reading approx. 250 microamps	H.R. Avometer 8S or 8SX Microammeter	12945 54148
Connector - See Note 1	-	64960

- NOTES
1. This connector is supplied in the "Box of Flexible Connectors for A.P. 67166 Noise Generators", and is required for CT212 and CT218.
 2. If the signal generator or test oscillator will not cover the higher frequency end of the frequency band, the second harmonic should be used.
 3. The high resistance Avometer (Model 8) is used as a tuning indicator, reading second detector current. Alternatively, the CT82 Output Meter, or Decibel Meter Portable No. 3, may be used as an indicator, reading AF output power. The former method is preferred.
 4. Special items No. 3 and No. 4 will be required. (See para. 6 under General Instructions.)

The Drill in Outline

31.

STEPS

- | | |
|--|-------|
| Remove receiver from case. Connect up test equipment. Switch on. | 1-4 |
| Turn the tuning control to its low-frequency limit, and set the cursor to line up with the end of the scale. Adjust the local oscillator trimmers so that the tuning scale frequency agrees with the test oscillator frequency at the two alignment points marked +. | 5-7 |
| Bring the RF circuits into alignment on all frequency bands. | 8-14 |
| Check that the calibration 'zero' is accurately aligned to the calibration mark on the scale. | 15-17 |

CONNECTION DIAGRAMS RF ALIGNMENT

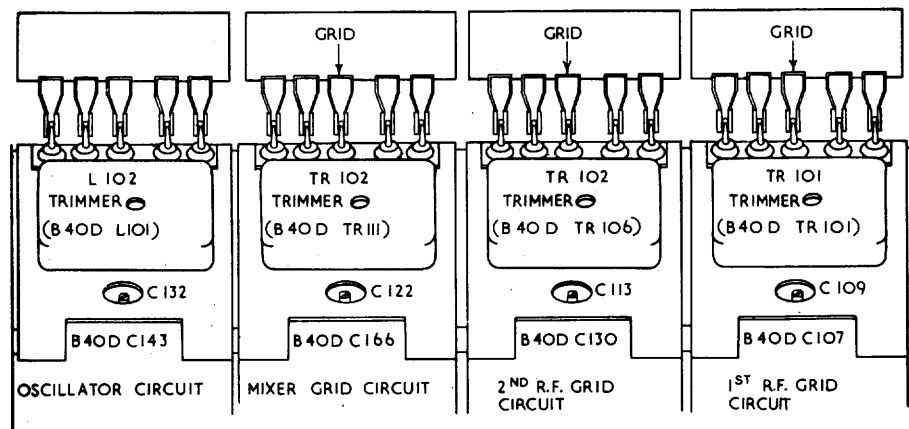

DETAILS OF R.F. COIL ASSEMBLY

FIG. 13

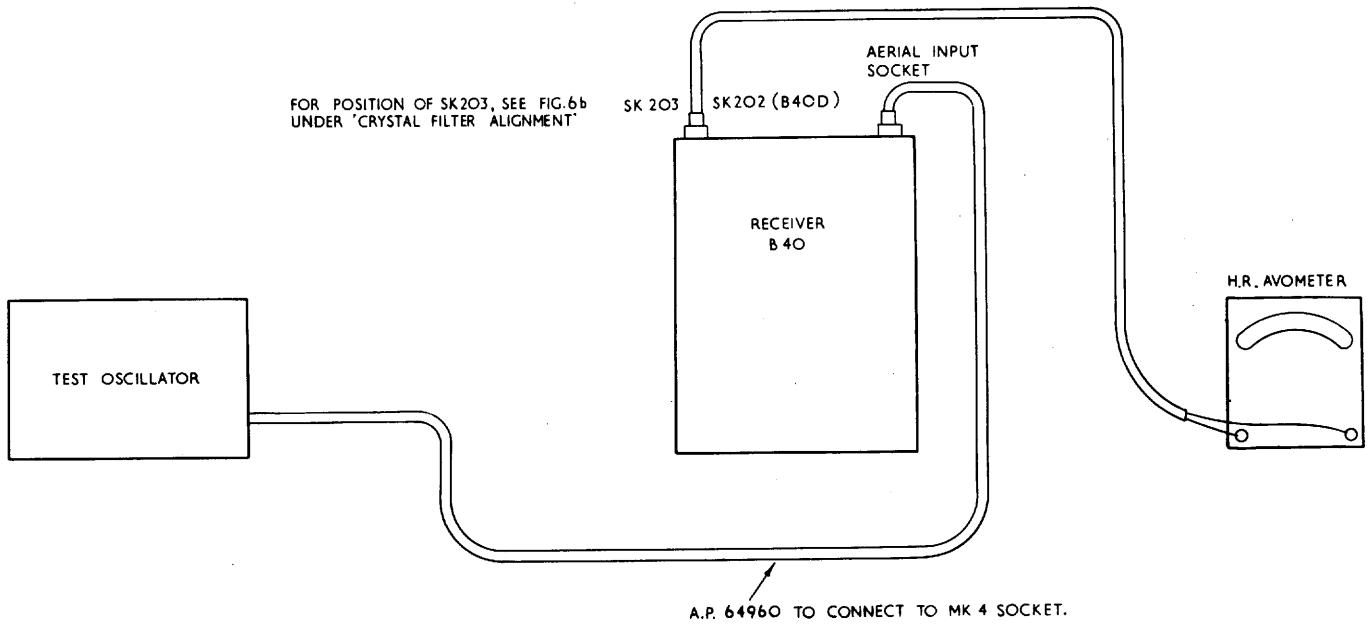

FIG. 14(a)

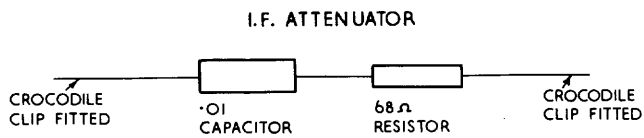

FIG. 14(b)

The Drill in Detail

TEST EQUIPMENT CONNECTION DIAGRAMS
RF ALIGNMENT

32.

STEP

ACTION

- 1 Remove receiver from its case and remove the side panel. Switch on receiver and test oscillator and allow equipment to warm through for 30 minutes.
- 2 Receiver controls as follows:-
 - (1) ANTI-CROSS MOD. Control fully clockwise.
 - (2) CRYSTAL switch to OFF.
 - (3) A.F. GAIN control fully clockwise (RV.224).
 - (4) GAIN control fully clockwise (RV.305/309)
 - (5) L.S. switch to ON.

STEPACTION

- (6) LIMITER switch to OFF.
- (7) Output switch (at back of receiver) toward front of receiver, (unless an output meter is connected across pins A and B of 6-pin output plug).

(8)

CONTROL	B4O/A	B4OB/C/D
BANDWIDTH SWITCH	NARROW	3 kc/s
SYSTEM SWITCH	MANUAL	TUNE
A.G.C. SWITCH	-	OFF

- (9) WAVEBAND switch to BAND 1.

NOTE The explanation will be given in terms of this Band.

- (10) TUNING control fully anti-clockwise. Set the cursor frame so that the pointers line up with the low-frequency end of the scales. (The cursor must remain in this position throughout the alignment.) Tune to 1.52 Mc/s. i.e. the alignment position indicated by a + on Band 1.

- 3 Reduce the sensitivity of the receiver IF amplifier by connecting the IF attenuator, i.e. the 0.01 μ F capacitor and 68 ohm resistor in series (Item 4 para. 6) between the grid of the 2nd IF amplifier (V202) and earth. (See Fig. 1 under "IF Alignment" for valve pin numbers and Fig. 14(b) details of attenuator.) This reduces IF voltage by about 40 dB.

- 4 Test oscillator. Adjust to:-

C.W.

Tune to 1.52 Mc/s.

Output - approx. 100 microvolts. If RF stages are badly misaligned, a larger output will be necessary.

Connect output to receiver aerial socket.

- 5 Adjust the local oscillator trimming capacitor (C132, B4OD-C143) for zero beat note in the telephones. (See Fig. 13 for trimmer identification). Increasing the output level of the test oscillator as necessary, check that a beat note can be heard in the receiver loudspeaker when the test oscillator tuning is varied around a setting 1 Mc/s GREATER than its original setting, i.e. for BAND 1, 2.52 Mc/s. Check that a beat note cannot be heard when the test oscillator is varied around a setting 1 Mc/s LOWER than its original setting.

STEPACTION

- 6 Tune the receiver and the test oscillator to 0.67 Mc/s. Adjust the local oscillator inductance trimmer for zero beat in monitor L.S. or telephones.
- 7 Repeat steps (4), (5) and (6) until further trimming is unnecessary.
- 8 (a) B4O/A - Stop the b.f.o. oscillating by connecting a 0.01 μF capacitor between the grid of the b.f.o. valve and earth. (The grid of the b.f.o. valve can be identified from Fig. 1 under "IF Alignment".)
- (b) B4OB/C/D - SYSTEM switch to R/T.
- 9 Adjust AVOMETER to read d.c. microamps at a convenient level when plugged in to SK.203, (or output meter to 6 pin plug) as in Fig. 14(a).
- 10 If using an output meter as a tuning indicator, switch on test oscillator modulation, at 400 or 1000 cycles (30% depth if variable). The test oscillator should remain on c.w. if using a second detector current indicator. In both cases tune to 1.52 Mc/s.
- 11 Adjust the RF circuit capacity trimmers C122, C113 and C109 (in that order) (B4OD; C166, C130, C107) for maximum reading in the Avometer (or output meter if being used).
- 12 Set the test oscillator to 0.67 Mc/s and tune the receiver accurately to it. Adjust the RF circuits inductance trimmers in TR103, TR102 and TR101 (TR111, TR106 and TR101 in B4OD) (in that order) for maximum reading in the Avometer or output meter.
- 13 Repeat steps (11) and (12) until no further appreciable improvement in output can be obtained, the final adjustments being made at 1.52 Mc/s.
- 14 Repeat this procedure on the remaining frequency bands of the receiver, trimming at the high frequency end of the band with the capacitor trimmers and at the low frequency end of the band with the inductance trimmers, at the trimming points indicated by a +. The following table indicates the trimming frequencies.

BAND	LOW FREQUENCY	HIGH FREQUENCY
1	0.67 Mc/s	1.52 Mc/s
2	1.66 Mc/s	3.8 Mc/s
3	4.11 Mc/s	9.2 Mc/s
4	9.8 Mc/s	17.4 Mc/s
5	18 Mc/s	29 Mc/s

STEPACTION

- 15 Disconnect the test oscillator, the Avometer, and the IF attenuator from the receiver B40/A, remove the b.f.o. grid-shortening capacitor.
- 16 SYSTEM switch to CAL. Check that the calibration "spots" on the tuning dial coincide with the zero beat position of the calibrating signal. Providing the zero beat applicable to the calibration spots nearest the tracking points lie within the limits given below, calibration is satisfactory. If not, the two local oscillator trimming controls for the waveband in question should be readjusted to lie within the limits. This will also entail re-alignment of the waveband in question.

WAVEBAND	LOW FREQUENCY END	HIGH FREQUENCY END
5	17.9 - 18.1 Mc/s	28.85 - 29.15 Mc/s
4	9.95 - 10.05 Mc/s	17.4 - 17.6 Mc/s
3	3.98 - 4.02 Mc/s	8.95 - 9.05 Mc/s
2	1.99 - 2.01 Mc/s	3.98 - 4.02 Mc/s
1	0.995 - 1.005 Mc/s	1.49 - 1.51 Mc/s

Overall Method of Alignment

33. It has been assumed that RF alignment is sufficiently accurate, before commencing realignment, to permit a signal to be fed through the receiver from the aerial terminal. This will normally be the case in ships.

Should this not be so, the following overall method should be followed, using the principles already given.

- (1) Connect test oscillator to grid of mixer (see Fig. 13) roughly align the two trimmers in the mixer grid circuit for maximum second detector or output meter indication.
- (2) Connect test oscillator to grid of 2nd RF amplifier valve. Roughly align the two trimmers in the second RF amplifier grid circuit.
- (3) Connect test oscillator to aerial. Roughly align the two trimmers in the 1st RF amplifier grid circuit.

Carry out complete RF alignment as given in Steps (1) to (16).

CHAPTER 7

PERFORMANCE TESTS

CONTENTS LIST

<u>INTRODUCTION</u>	Para.
Arrangement and layout of information	1-2
Precautions to be used in connecting up test equipment	3-7
Test Equipment to be used	8-9
Connector Details	10-17
<u>SUMMARY OF THE TESTS AND THEIR OBJECT</u>	
<u>PART A</u>	
Noise Factor Test using Noise Generator CT82	18
Overall Sensitivity Test using Noise Generator CT82	19
Deductions to be drawn from CT82 readings	20
Valve electrode potentials	21
<u>PART B</u>	
Signal + noise/noise ratio and overall sensitivity	22
Overall audio frequency response	23
Output levels	24
Image rejection	25
A.G.C. performance	26
Anti-Cross-Modulation	27
Crystal controlled operation	28
Noise limiter action	29
AF gain	30
IF response	31
IF gain	32
IF stage gain	33
RF gain	34
<u>PART A</u>	
<u>PERFORMANCE TESTS PRIMARILY FOR THE USE OF SHIPS</u>	
<u>NOISE FACTOR MEASUREMENT</u>	35-36
Test equipment required	35
The Drill	36
<u>SENSITIVITY MEASUREMENT USING CT82 NOISE GENERATOR</u>	37-38
The Drill	37
Acceptance level of performance	38
<u>RESTORATION OF PERFORMANCE</u>	39

	Para.
<u>INTERPRETATION OF CT82 READINGS</u>	40 - 41
Diagnosis of the cause of poor noise factor	40
Diagnosis of the cause of poor sensitivity	41
<u>VALVE ELECTRODE POTENTIALS B40/A/B/C</u>	42 - 44
Test equipment to be used	43
Valve electrode potentials	44
<u>LOCAL OSCILLATOR OUTPUT</u>	45
<u>VALVE ELECTRODE POTENTIALS B40D</u>	46

PART B

PERFORMANCE TESTS MORE SUITABLE FOR USE IN DEPOT SHIPS AND DOCKYARDS

<u>SIGNAL + NOISE/NOISE RATIO AND OVERALL SENSITIVITY</u>	47 - 49
Test equipment required	47
Test requirement	48
The Drill	49
<u>OVERALL AUDIO-FREQUENCY RESPONSE</u>	50 - 52
Test equipment required	50
Test requirement	51
The Drill	52
<u>OUTPUT LEVELS</u>	53 - 55
Test equipment required	53
Test requirement	54
The Drill	55
<u>IMAGE REJECTION</u>	56 - 58
Test equipment required	56
Test requirement	57
The Drill	58
<u>A.G.C. PERFORMANCE</u>	59 - 61
Test equipment required	59
Test requirement	60
The Drill	61
<u>ANTI-CROSS-MODULATION</u>	62 - 64
Test equipment required	62
Test requirement	63
The Drill	64

FIGURES

Circuit. Attenuator, Des. 38, A.P.63693

Fig.

1

TEST EQUIPMENT DIAGRAMS

Noise Factor and Sensitivity Measurements

2

Signal + Noise/Noise Ratio and Overall Sensitivity

3 a/b

Overall Audio Frequency Response

4

Output Levels

5

Image Rejection

6

A.G.C. Performance

7

Anti-Cross-Modulation

8

Crystal Controlled Operation

9

Noise Limiter Action

10

AF Gain

11 and 12

IF Response with Signal Generator

13

IF Response with Frequency Swept Oscillator

14 a/b

IF Response Curves

15

TEST EQUIPMENT DIAGRAMS

IF Gain (Overall)

16

IF Stage Gain

17 a/b/c and 18

RF Gain

19 a/b/c, 20
a/b/c and 21

CHAPTER 7

PERFORMANCE TESTS

INTRODUCTION

Arrangement and layout of the information

1. The performance of a receiver needs to be checked:-
 - (a) As an aid to diagnosis during fault location.
 - (b) To determine whether the receiver is still working within satisfactory limits.
 - (c) By the Dockyard, following extensive repair, so as to ensure that the receiver meets the full Test Specification.
2. The tests in (a) and (b) above, entail the use of simple test equipment which is found in most ships. They have been grouped together in Part A, which is therefore primarily for the use of ships. Part B contains the tests applicable to (c) above. These tests will seldom be carried out in ships, which will in any case not always possess the necessary test equipment or facilities. The information in Part B is therefore principally for the benefit of dockyards and depot ships, but other ships may make use of the information when necessary.

The tests are designed to ensure that the overall performance of the receiver is satisfactory, and that the special facilities afforded by the receiver are functioning correctly. In addition to the overall tests, there are individual tests for the RF, IF and AF sections. Individual stage gains may also be checked. These section checks are necessary when the overall sensitivity is below the specified figure.

The tests have been arranged so that overall tests are carried out first. Functional tests of special circuits are given next. The last group, which may be loosely termed fault-finding checks, should be necessary only if the overall tests are unsatisfactory.

Precautions to be observed in connecting-up test equipment

3. Receiver and test equipment must be connected to a common earth.
4. All connecting leads must be as short as possible. Screened leads, with the screen connected to a common earth must be used for all connectors carrying current at radio frequencies.
5. The receiver and associated test equipment must be switched on and allowed to warm up for at least one hour, before a test is carried out, in the case of B4OD, the receiver should be switched on at least 6 hours before the b.f.o. test. (See Handbook for RATT B.R.2133). The SYSTEM switch should not be left in the R/T position, otherwise the b.f.o. valve will not warm up with the rest of the receiver.

6. In setting-up the test rig, only those controls whose setting is important are mentioned. The remainder may be ignored.
7. When feeding in RF at the low impedance aerial input of the receiver, the signal generator must be connected by means of a screened lead of the correct matching impedance, and (in the case of A.P. 54704 Sig. Gen.) a suitable attenuator. Specific details will be given in the instructions for each performance measurement concerned. Where signal generator output voltages to the receiver are quoted, they refer to the figures actually set up on the signal generator attenuator.

Test Equipment to be used

8. Signal Generator CT218 will replace A.P. 54704/A Signal Generator for use with B40 receivers. In the meantime, the latter should be used. The instructions have been framed to cover the use of either of these instruments, although any signal generator of suitable accuracy which provides the required facilities, may be employed. The necessity for correct matching of the signal generator output, the connecting lead, and the receiver input must be remembered. If this is not carried out, the value of the voltage at the receiver input will be uncertain.
9. Since the modulation frequencies of the two signal generators in question are not the same, 1000 c/s has been specified for CT218, and 400 c/s for A.P. 54704/A. This difference in modulation frequency should make no significant difference to the figures achieved for the test in question. The difference in fact amounts to a little over 1 dB. Other test equipment specified is C.N.R.T.E., normally supplied to the ships or dockyards concerned.

Connector details

10. The following connectors are designed to conform with the alignment and testing requirements for the B40 and B41 Receivers, when using A.P. 54704/A Signal Generator.

Connector Input

11. This connector comprises two items; an attenuator and a connector. The attenuator plugs directly into the Signal Generator A.P. 54704/A, output and is joined to the receiver input by the connector.

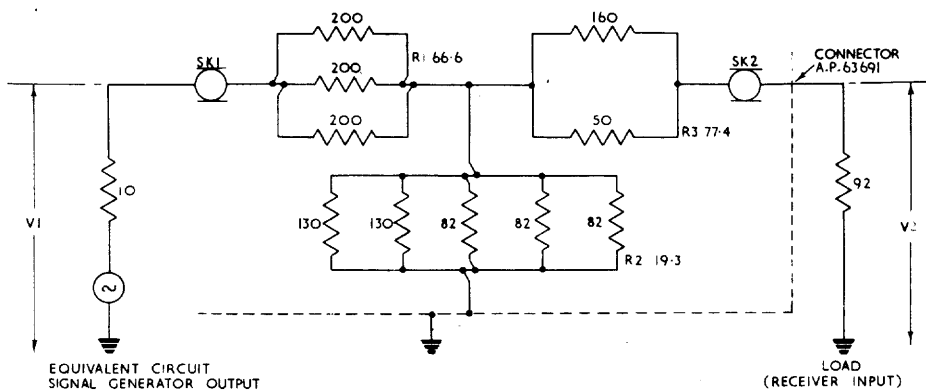

ATTENUATOR A.P. 63693 FIG. 1

Attenuator Unit, Design 38, 20 dB, 10 ohm input, 92 ohm load A.P.63693

12. The attenuator is housed in a small metal screening box containing two resistors R1 and R3 in series, with resistor R2 connected from the centre point to earth. The box is fitted with two connector terminations, one (SK1) to fit the output of the Signal Generator (A.P.54704/A), whilst the other (SK2) is an A.P.62151 connector. The attenuator is designed, so that when used with Signal Generator A.P.54704/A, (output voltage V1) and working into a nominal 92 ohm load represented by the receiver input, the voltage V2 across this load is given by $\frac{V1}{\sqrt{2}} = \frac{1}{10}$ or 20 dB voltage ratio.

Connector Flexible Screened, 3 ft long A.P.63691

13. This is used to connect the attenuator to the receiver. It comprises a suitable length of Uniradio No. 31 cable (A.P.13831), with a characteristic impedance of 92 ohms. This cable is fitted at one end with a plug (A.P.62150); the other end terminates with a 4 pin Mk. 4 socket (A.P.560110) to fit into the aerial plug on the receiver (PL101). The cable connector is connected to Pin "C"; Pins "A" and "B" are connected together and Pin "D" is left unconnected.

Connector IF (A.P.63692)

14. Comprises a suitable length of Uniradio No. 31 cable (A.P.13831); fitted at one end with A.P.62150 plug to fit into the A.P.63693 Attenuator output. The other end terminates in a 0.01 μ F capacitor screened by a small piece of brass tube which is sweated to the cable screen. Two short flexible insulated leads, each about three inches long and terminating in a "crocodile" clip, are connected to capacitor and screen respectively. A rubber cover is fitted over the brass screening tube. The connector is primarily used for feeding signals into the IF amplifier, although in one case it is used for taking RF measurements.

NOTE:- If these special connectors are not available, they should be made up.

15. When using Signal Generator CT218, all leads for connection between the signal generator and the receiver (if not supplied with the signal generator), may be found in the "Box of Flexible Connectors for Pattern 67166 Noise Generator CT82".

16. The output connector employed for the tests given in Section "B", consists of a 6 Pin Mark 4 socket (Free termination) and a twisted pair of different coloured wires (flex, or P.V.C. insulated), one end of which is connected to Pins A and B of the socket. Pattern numbers for all the items to assemble the socket are given in Chapter 8 Para. 18, this chapter also details approved methods of assembling the socket with the leads, and soldering to the pins. The leads should be about four feet long, with the free ends connected to spade terminals, or crocodile clips. In use, the wire from Pin A must be connected to the earth terminal of the output meter. In early receivers with a 'W' type output outlet plug the corresponding item must be used instead of the Mark 4 socket. (See also Chap. 6, Para. 6, Item 2).

17. Other special items and leads of a minor nature, are specified in the instructions for the test concerned.

SUMMARY OF THE TESTS, AND THEIR OBJECT

PART A

Noise Factor Test using Noise Generator CT82

18. This test determines whether or not the amount of noise which is produced within the receiver (as opposed to atmospheric noise picked up in the aerial) is within the prescribed limits.

Noise Output Test using Noise Generator CT82

19. Having established that the amount of noise being generated in the receiver is normal, the output due to the amplification of that noise by the receiver can be measured. Tests have established the output which can be expected from a receiver whose performance satisfies the Test Specification for overall gain. (See also Para.37, step 6 for Noise Gain). This standard of performance is bound to fall off during service, and a lower limit of acceptable performance has therefore been fixed.

NOTE:- As an "in situ" test to establish that a receiver is still performing satisfactorily, it is normally only necessary to carry out a Noise Factor and noise output check at the centre of each wave-band.

As a check on performance after alignment, the tests should be carried out at the HF and LF end of each band, in addition to centre-band. This test should also be carried out subsequently, at infrequent intervals.

Deductions to be drawn from CT82 readings

20. Where either noise factor or noise output readings fail to satisfy the requirements laid down, intelligent study of the figures achieved can do much to identify the source of poor performance. Further details are given under the heading "Interpretation of CT82 readings" paragraphs 40 and 41.

Valve electrode potentials

21. The first phase in receiver fault-finding is to narrow down the investigation to a particular unit or circuit. It may then be possible to locate the faulty component by checking the electrode potentials of the valve in the suspected circuit. It is desirable to place certain receiver controls in pre-determined positions in order to obtain controlled conditions for the test.

PART B

Signal + Noise/Noise ratio, and overall sensitivity

- 22.(a) The receiver should be capable of an output of 500 milliwatts when fed with an RF input voltage of 1 microvolt at the low impedance aerial connection. This output is due to signal and receiver noise i.e. Signal + Noise.
- (b) When the signal is switched off, the output should fall by at least 22 dB. The output now remaining is due to receiver noise alone.

- (c) The Signal + Noise/Noise ratio is therefore quoted as 22 dB, and the sensitivity as 500 milliwatts for 1 microvolt. These are the performance figures which the receiver should achieve.

Overall Audio-Frequency Response

- 23. (a) This test ensures that the AF response at the receiver output conforms to the following requirements:-
 - (i) With a reference level established at the maximum output obtainable over the AF band, the output at 300 c/s and 3000 c/s modulation should not fall by more than 4 dB below the reference level.
 - (ii) The output at 80 c/s modulation frequency should fall by at least 13 dB below the reference level.
- (b) An RF signal at 1.05 Mc/s is fed in at the receiver aerial connection. The modulation applied to this signal is varied from 80 c/s to 3 kc/s, and the AF response as indicated by the output meter readings is noted. The amplitude of the RF signal, and the depth of modulation, is maintained at a constant level.
- (c) Besides checking the response of the AF stages, this test provides useful information as to the alignment of the remainder of the receiver, since misalignment of the RF or IF stages would probably influence the shape of the AF response curve.

Output levels

- 24. (a) This test ensures that the output levels are not less than:-

LINE	-	5 milliwatts	}	From output socket
PHONES	-	3.5 milliwatts		
PHONE JACK 1 - 3.5 milliwatts				
PHONE JACK 2 - 3.5 milliwatts				
- (b) The reference level of output is 500 milliwatts from the loudspeaker connections of the output plug.

Image Rejection

- 25. (a) An intermediate frequency signal of 500 kc/s may be obtained with an incoming signal 500 kc/s above or below the local oscillator frequency.
- (b) The local oscillator operates at 500 kc/s above the incoming signal. The test is therefore designed to ensure that at the frequency where image interference (i.e. second channel interference) could occur - that is, 1 Mc/s higher than the fundamental frequency -, adequate attenuation is achieved in the RF stages before the interfering signal reaches the Mixer stage.

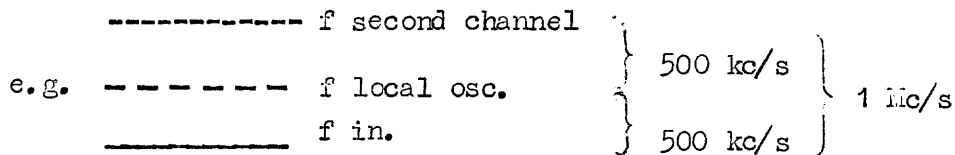

A.G.C. Performance

- 26.
- (a) The function of the a.g.c. system is to maintain a reasonably constant receiver output with an input signal which is varying over a wide voltage range.
 - (b) The test is designed to ensure that the receiver output does not vary by more than 3.5 dB, whilst the input RF voltage is varied over a range of 77 dB.

Anti-Cross-Modulation

- 27.
- (a) This test is designed to check the range of control of the ANTI-CROSS-MODULATION potentiometer. With this potentiometer turned fully clockwise - that is, permitting the first RF stage to give maximum gain - the receiver GAIN control is adjusted so that an input of 100 microvolts at the aerial terminal produces an output of 500 milliwatts.
 - (b) When the ANTI-CROSS-MODULATION control is turned to the other end of its travel i.e. fully anti-clockwise the RF stage gain is reduced. In order to produce an output of 500 mW from the receiver, the signal generator output must now be increased by at least 15 dB.

Crystal controlled operation

28. Where exceptional receiver frequency stability is required, the local oscillator frequency may be crystal-controlled. This test checks that the receiver operates satisfactorily in this condition. The test is purely functional.

Noise Limiter Action

- 29.
- (a) The noise LIMITER control should be effective on signals whose modulation depth lies between 10% and 60%.
 - (b) In this test, an RF voltage modulated successively between 10% and 60%, is fed to the grid of the mixer valve. At each variation of depth of modulation the receiver limiter control is operated to ensure that the receiver output, which is displayed as a trace on the c.r.t. of an oscilloscope, is limited by the action of the LIMITER control.

AF Gain

- 30.
- (a) The gain of the audio frequency stages is checked at a nominal frequency of 1000 c/s. An input of 0.15 volts to the grid of the first AF valve should produce a reading of 500 milliwatts or more in the output meter.
 - (b) Due to the poor setting accuracy of the "Output Voltage" scale of the AF Oscillator at low voltages, an output of 15 volts is used.

This is reduced to an input of 0.15 volts at the receiver by means of a 100/1 (approx.) voltage divider between AF Oscillator and receiver.

- (c) For this test, the Power Unit should be removed from the receiver.

IF response - adjacent channel selectivity -

- 31.
- (a) This test ensures that, when the receiver is in the NARROW or 3 kc/s position of the BANDWIDTH switch, the bandwidth of the receiver is greater than 2.5 kc/s wide at 6 dB down and less than 9 kc/s at 40 dB down. When the BANDWIDTH switch is at WIDE or 8 kc/s, the bandwidth of the receiver should be greater than 8 kc/s at 6 dB down, and less than 25 kc/s at 40 dB down.
 - (b) The incremental tuning scale of the signal generator is first calibrated, to provide an accurate measurement of bandwidth.
 - (c) The signal generator output voltage and the receiver output power are then established at fixed levels. The signal generator output is increased by 6 dB, and the output frequency detuned until the receiver output falls to its original figure. The bandwidth is then measured by means of the incremental tuning scale.
 - (d) This test is repeated on the WIDE or 8 kc/s position of the BANDWIDTH switch.
 - (e) An alternative method, involving the use of a frequency-swept oscillator and oscilloscope, is included. Although this method is preferred, it is not often applicable, since the frequency swept oscillator is not generally available.
 - (f) By this method, the response curve due to the IF voltage at the second detector is displayed on an oscilloscope, a swept frequency about 500 kc/s being fed in at the mixer grid. Using the scan length as a scale, the bandwidth at 6 dB and 40 dB down from resonance, can be measured for each position of the BANDWIDTH switch.

IF Gain

Overall Gain

- 32.
- (a) This test ensures that the voltage gain over the IF stages is correct. It is carried out with the BANDWIDTH switch in the WIDE (B40/A) or 8 kc/s (B40B/C/D) position, and also in the NARROW (B40/A) or 3 kc/s (B40B/C/D) position.
 - (b) An RF signal of 100 microvolts, modulated 30% at 400 or 1000 c/s injected at the mixer grid, should produce a receiver output of at least 500 milliwatts with the BANDWIDTH switch in its widest bandwidth position.
 - (c) With the BANDWIDTH switch set to NARROW or 3 kc/s as applicable, an RF signal of 35 microvolts, modulated as before, should produce an output of at least 500 milliwatts.

IF Stage gain

33. Should the overall stage gain not reach the specified figure, it is necessary to determine which stage(s) are at fault. Individual stage gain figures are therefore taken.

RF gain

- 34.
- (a) In this test, the gain over the entire RF amplifier is measured. Should this prove unsatisfactory the gain of individual RF stages can be checked. The gain is measured indirectly, in the sense that if the receiver is operating within satisfactory limits, a given RF input should produce an AF output of 500 mW. It is possible to derive stage gain figures if so desired.
 - (b) When the Signal Generator A.P.54704A is used, a 20 dB attenuator is inserted between it and the receiver. In addition, when the signal generator is connected to the grid of a valve, a special lead incorporating a screened 0.01 μ F capacitor is employed.
 - (c) When the Signal Generator CT218 is used, it is connected directly to the receiver when feeding the aerial connector, or through a special lead and 0.01 μ F capacitor when connected to the grid of the mixer or RF valves.
 - (d) Irrespective of the signal generator used, the IF gain is reduced when the signal voltage is fed in at the first RF grid, or at the aerial connector. This is achieved by connecting an attenuator, consisting of a 0.01 μ F capacitor and a 68 ohm resistor in series, between the grid of the second IF valve, and the chassis.
 - (e) To check individual stage gain, commencing on Band 1 at 1.05 Mc/s, a signal is fed in at the mixer grid, sufficient to produce a reading of 500 mW, in the output meter. The signal generator output voltage is noted, to see that it does not exceed the maximum value permitted, as laid down in the table provided in the Test Instructions. The procedure is repeated on the same frequency, but with the signal fed in through the second RF valve grid, the first RF valve grid, and lastly the aerial connector, in that order, the value of signal generator output voltage being checked at each stage.
 - (f) The entire procedure is repeated at a given frequency in each waveband.

PART A

PERFORMANCE TESTS PRIMARILY FOR THE USE OF SHIPS

NOISE FACTOR MEASUREMENT

Test Equipment required

35.

Test Equipment Description	Identity	A.P.
Noise Generator	CT82 *	67166
Box of flexible connectors for use with CT82	-	60875A

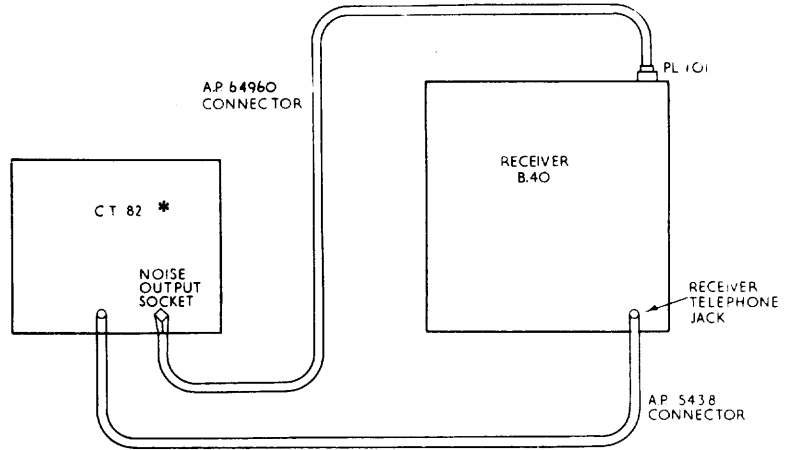

CONNECT C.T.82 NOISE OUTPUT TO RECEIVER
 LOW IMPEDANCE AERIAL INPUT CONNECT
 C.T.82 "AUDIO IN" SOCKET TO RECEIVER
 TELEPHONE JACK.
 * CT410 may also be used. Set input impedance to 600 ohms
 and read 75 ohm dB scale (see B.R.1771(43)).
 TEST EQUIPMENT CONNECTION DIAGRAM FIG. 2

The Drill

36. STEP

PROCEDURE

1

Set the receiver controls as follows:-

- (1) NOISE limiter to OFF
- (2) BANDWIDTH switch to 3 kc/s
- (3) MONITOR L.S. switch to ON
- (4)

RECEIVER	SYSTEM SWITCH	A. G. C. SWITCH
B40/A	Manual	-
B40B/C/D	Tune	OFF

- (5) CRYSTAL switch to OFF
- (6) ANTI-CROSS-MOD. control, fully clockwise
- (7) GAIN control, fully clockwise
- (8) AF GAIN control, adjust as described overleaf
- (9) DUMMY LOAD switch. Toggle towards front of set.

NOTE:- The b.f.o. is in circuit with the object of operating the second detector in the linear range.

STEPPROCEDURE (Contd.)

- 2 Set the CT82 controls as follows:-
 - (1) "Noise out" switch to 75 ohms
 - (2) "Audio in" switch to HIGH (if the output of the receiver is low it may be necessary to use either the 'Medium' or 'Low' switch positions).
- 3 Tune the B40 receiver to the mid-band frequency on Range 1.
- 4 Adjust AF gain for a midscale reading (i.e. 10 dB) in the output meter with the Diode Current switch to "OFF".
- 5 Switch the Diode Current switch to "10 mA".
- 6 Rotate the Diode Current control until the reading in the output meter has increased by 3 dB. If the Noise Factor is higher than 11 dB it will be necessary to switch to the "100 mA" position to obtain a 3 dB increase.
- 7 Read off noise factor on the 75 ohm scale of the Noise Factor Meter.
- 8 Repeat the test on all bands, with the receiver tuned successively to the remaining mid-band frequencies, then (if desired) to the LF and HF tracking points.

NOISE OUTPUT MEASUREMENT USING NOISE GENERATOR CT82The Drill

37. Test Equipment connections as for Noise Factor measurement.

STEPPROCEDURE

- 1 Set receiver control as for measurement of noise factor, but adjust both gain controls to maximum. Tune to the centre-band frequency on Range 1.
- 2 Set CT82 control as for measurement of noise factor with the Diode Current switch to "OFF", and the "Audio In" switch to "High".
- 3 Read noise output in dBs on the output meter. If the output of the receiver is so low that no reading is obtained, turn the "Audio In" switch to "Medium" or "Low" as appropriate. Note the reading obtained and whether measured on "High" (H), "Medium" (M), or "Low" (L).

NOTE:- An output which reads 0 dB on the "High" position of the switch will read approximately 16 dB on the "Low" position of the switch.

STEP

PROCEDURE (Contd.)

- 4 Repeat the test at the mid-band frequency on the remaining ranges, and at the LF and HF tracking points if necessary.
- 5 Convert all Noise Output readings in terms of the "Audio In" switch set to "Low".

NOTE:- To convert Noise Output readings from "High" to "Low" add 15.5 dB.
 To convert from "Medium" to "Low" add 6.0 dB.

Because Noise Output is in part dependent on Noise Factor, (a receiver whose Noise Factor increases by 3 dB will have a Noise Output 3 dB greater, assuming its gain remains constant), it has been found most convenient when comparing receivers of the same type (i.e. in this case the B40 series), to work in terms of Noise Gain and Noise Factor. Noise Gain figures, which are a measure of receiver gain, are obtained for B40/A/B/C/D by subtracting the Noise Factor at any given frequency from the Noise Output referred to Low at that frequency, both quantities being expressed in Decibels.

NOISE GAIN (dB) = NOISE OUTPUT LOW (dB) - NOISE FACTOR (dB).
 COMPARISON BETWEEN RECEIVERS OF DIFFERING TYPES ON THE BASIS OF NOISE GAIN FIGURES IS INVALID.

Levels of Performance (Ships only)

38. (a) In receivers which only just satisfy the Test Specification criteria of performance for signal-to-noise ratio, the following average results have been obtained over the whole band:-

"Noise factor should not be worse than 9.0 dB."

All new receivers must reach the above standard of performance. However, it is found in practice that due to allowed component tolerances, many new or repaired receivers attain a standard of performance considerably better than that quoted above, and in some cases noise factors as good as 1 dB may be found. This is quite in order and the table below gives the noise factor to be expected from receivers on installation.

NOISE FACTOR (See Note 1 below)

Noise factors should be taken as soon as possible after the new or repaired receiver has been installed, and these figures should be recorded as the initial figures. These results obtained should be as indicated in the table, any cases where the noise factor is more than 1 dB worse, i.e. greater than the higher figure shown in the table, the fact should be brought to the notice of the issuing authority of the receiver. Subsequently the receiver should be checked periodically as indicated on the maintenance schedule and a slow deterioration in noise factor is permissible (see Note 2).

TABLE

NOISE FACTOR AT BOTTOM, MIDDLE AND TOP OF BAND	
Range 1	Normally lies between 1 dB and 9.0 dB
" 2	" " " 1 dB and 9.0 dB
" 3	" " " 2 dB and 9.0 dB
" 4	" " " 3 dB and 9.0 dB
" 5	" " " 6 dB and 9.0 dB

NOISE GAIN (See Notes below)

The actual figure obtained for noise gain is somewhat dependent on the location of the receiver, e.g. in a screened cubicle, lower noise gains may be obtained than in a "noisy" location or where there is considerable interference on the mains supply. For this reason it is better to install the receiver in its bay and take a series of noise factor and noise gain readings. If these readings are taken after the initial installation of the receiver or subsequent to its re-installation after repair, they should be used as the initial noise gain and any subsequent results showing a sudden deterioration of more than 3 dB should be investigated. A steady deterioration in noise gain is permissible (see Note 2 below).

NOTE 1

The recommended practice as stated is to obtain the noise factor and noise gain when the receiver is known to be in good condition and use these results as a basis for comparison of later periodic readings. In general the noise factors will tend to worsen, i.e. increase and the noise gain to decrease with time. A steady deterioration is to be expected and only sudden changes of several dB need be investigated.

NOTE 2

It is emphasised that the figures given in the table only apply when the receiver is first installed and the receiver should not normally be defected if the results gradually deteriorate below those given in the table. The results given in para. (b) below are the noise results which should be obtained, when a receiver has reached this low level of performance, effort should be made to discover the reason, see table of Fault diagnosis using CT82, and either the necessary action taken to restore the performance or a copy of the results (not the receiver) sent to the Dockyard or base for information and proposed action. Re-alignment of the receiver should not be attempted except in an emergency and in general it will be found that the performance can be restored without re-alignment. (See table of Fault diagnosis using CT82.)

NOTE 3

The Noise Gain figures are calculated as shown in para. 37, step 6.

NOTE 4

In B40C/D the noise factors obtained are usually slightly worse than those for B40A/B. However the permissible limits given apply to all B40 type receiver.

NOTE 5

The level of performance quoted in para. 38(a) using the CT82 for B40 type receivers also applies to 62B. However, due to its location, interference can sometimes give rise to bad noise factors, even on installation. In this event, the results only should be returned to the installation authority for comment and action.

- (b) In general, it is considered that B40 receivers which do not reach the standard of Noise Factor and Noise Gain performance shown below should be considered un-serviceable and removed to the E.M.R. for investigation at the earliest opportunity.

Noise Factor: 15 dB on all ranges (CT82 & CT410); Noise Gain: -10 dB using CT82 (-36 dB using CT410) on all ranges.

The minus sign of Noise Gain which occurs when receiver performance is poor need not lead to confusion if it is remembered, for example, that a Noise Gain of -7 dB is 3 dB better than a Noise Gain of -10 dB.

INTERPRETATION OF CT82 READINGS

Diagnosis of the causes of poor Noise Factor and/or Noise Gain

39. The following table indicates some common faults.

NOTE 1:- Variations in supply voltage of $\pm 10V$ will cause variations in Noise Gain of ± 1.5 dB, Noise Factor remaining substantially the same.

NOTE 2:- Where a portion of the receiver is suspected from examination of the CT82 results, further more detailed tests will often be necessary to locate the defective component.

IMPORTANT NOTE: It is most important where receiver alignment is suspect, that all other possible causes are investigated before carrying out re-alignment. THIS MUST ONLY BE ATTEMPTED AS AN EMERGENCY MEASURE and the set must be made a Dockyard Defect at the earliest opportunity. (A.F.O. 534/57 refers).

FAULT DIAGNOSIS USING CT82 TEST RESULTS

	Symptom	Possible Fault	Location of Fault	Remedy
NOISE FACTOR FAULTS	High (Poor) Noise Factor on all bands	A. Bad contact in r.f. valves	A. r.f. valve and mixer valve	Move valves about in socket to give cleaning action on pins. Inspect holders.
	High (Poor) Noise Factor on all bands	B. r.f. valve failing	B. r.f. valve and mixer valve	Check valves on CT160 Valve tester, for emission etc. Replace faulty valves.
		C. Low r.f. gain	C. h.t. voltages or mains voltage low. Unswitched components in r.f. stages, i.e. any component common to all bands of the receiver.	Check using Avometer Model 7K. Check by-pass capacitors electrode voltages etc. in r.f. and mixer stages. Replace faulty component.
	High (Poor) Noise Factor on whole of one band.	r.f. gain low in that band only.	D. Switched components to that band, in r.f. and mixer circuits.	Check appropriate components, coils etc.
			E. Alignment of r.f. stages on that band only.	See important note at head of table. Realign r.f. stages and oscillator stage on that band only.

FAULT DIAGNOSIS USING CT82 TEST RESULTS (Contd.)

Symptom	Possible Fault	Location of Fault	Remedy
High (Poor) Noise Factor at one end of a band	r.f. gain low at that point	F. As in E above	See important note at head of table.
Noise Factor measurement not obtainable due to no increase in receiver Noise Output	No noise entering Receiver Aerial terminals	G. Noise Generator not operating	Check mains on, Diode current meter reading etc. See BR.1771(12) for fault finding.
		H. Connecting lead from Noise Generator to Receiver aerial terminals open or short circuited	Check for continuity and insulation.
		J. Receiver Noise Factor greater than 20 dB	Check overall gain etc. as indicated in Receiver handbook. Pay particular attention to first r.f. and mixer stages.
Noise Factor suddenly changes on one band only	r.f. gain Low on that band	K. See D, E, F above.	See important note at head of table.
Noise Factor suddenly changes in all bands	r.f. gain changed	L. r.f. stages of Receiver	Check h.t. mains voltage electrode voltages.
		M. Noise Generator fault	See B.R.1771(12).

NOISE FACTOR FAULTS

FAULT DIAGNOSIS USING CT82 TEST RESULTS (Contd.)

	Symptom	Possible Fault	Location of Fault	Remedy
NOISE GAIN FAULTS	Noise Gain Low on all bands, Noise Factor normal.	Receiver gain low.	N. h.t. voltage low. Mains voltage low.	
			P. Faulty components in non switched sections, e.g. by-pass capacitors.	Check electrode voltages use handbook maintenance methods.
			Q. Valve or Valves low in gain or emission.	Check a.f. overall gain, i.f. overall gain to locate fault. Check suspect valves on CT160 valve tester.
			R. B.F.O. not working properly.	Check according to handbook.
			S. i.f. alignment incorrect.	Realign i.f. as an <u>emergency</u> measure only. (See important note at head of table before attempting alignment.)
	Noise Gain Low on one band only. Noise Factor being normal.	r.f. gain low in mixer stage.	T. Switched components in r.f. stages and oscillator, particularly in the mixer stage.	Check these components.
			U. Alignment of r.f. stages and oscillator stage.	Try all other fault finding before attempting an r.f. realignment. See important note at head of table.
	Noise Gain Low on one end of one band only and Noise Factor Normal.	r.f. gain low at bad point.	V. As in T & U above.	
	Noise Gain Higher than usual	High Receiver gain.	W. Main voltage high. h.t. high.	Check using Avometer.
	Noise Gain Low on all bands. Noise Factor slight change.	B.F.O. frequency or level change.	X. B.F.O. circuit.	Check B.F.O. frequency and level as indicated in maintenance notes.

40. Spare.

41. Spare.

VALVE ELECTRODE POTENTIALS

42. In order to obtain the figures with reasonable certainty, the receiver should be operated with the controls set as follows:-

- (1) ANTI-CROSS-MOD. control, fully clockwise
- (2) CRYSTAL switch to OFF
- (3)

RECEIVER	BANDWIDTH SWITCH	SYSTEM SWITCH	A.G.C. SWITCH
B ₄ O/A	Narrow	Manual	-
B ₄ OB/C/D	3 kc/s	Tune	Off

- (4) LIMITER switch to OFF
- (5) OUTPUT switch at back of receiver, toggle to front of receiver
- (6) MONITOR L.S. switch to OFF
- (7) GAIN controls both fully clockwise.

Test Equipment to be used

- 43.
 - (a) The figures given overleaf were obtained using an Avometer Patt. 47A. If a different instrument is used, the results obtained may in certain instances differ considerably from those laid down, particularly where a voltage measurement is being made across a high impedance.
 - (b) The limits given are approximately 15% ± the normal reading.

Valve electrode potential tables (B40/A/B/C)

44. (a) RF Unit

Valve	Electrode	Meter range (volts)	Reading (volts)	Acceptable limits	
				From	To
1st RF valve V101	Anode	480	200	170	230
	Screen	480	200	170	230
	Cathode	480	65	55	75
2nd RF valve V102	Anode	480	100	85	115
	Screen	480	75	65	85
	Cathode	12	1.5	1.3	1.7
Frequency Changer V103	Anode	480	240	205	275
	Screen	480	65	55	75
	Cathode	12	1.8	1.6	2.0
Local Oscillator V104	Anode	480	150	125	175
	Screen	480	150	125	175

(b) AF and Power Unit

Valve (or socket)	Electrode	Meter range (volts)	Reading (volts)	Acceptable limits	
				From	To
SK301	Pin 1	480	250	215	265
	" 2	"	150	125	175
	" 4	"	200	170	230
	" 7	"	230	200	260
SK302 Gain control fully anti- clockwise (i.e.) Min. Gain	Pin 8 (R305 slider)	120	25	20	30
1st AF valve V301	Anode	480	80	70	90
	Screen	480	30	25	35
	Cathode	12	1.4	1.2	1.6
Output valve V302	Anode	480	250	215	265
	Screen	480	250	215	265
	Cathode	12	3.8	3.3	4.1

(c) IF Unit

Valve	Electrode	Meter range (volts)	Reading (volts)	Acceptable limits	
				From	To
1st IF valve V201	Anode	480	230	200	260
	Screen	480	60	50	70
	Cathode	12	2.1	1.9	2.3
2nd IF valve V202	Anode	480	230	200	260
	Screen	480	60	50	70
	Cathode	12	2	1.8	2.2
3rd IF valve V203	Anode	480	215	185	245
	Screen	480	85	75	95
	Cathode	12	2.5	2.2	2.8
A.G.C. diode V204a	Cathode (a.g.c. delay voltage)	120	10	8.5	11.5
B.F.O. (V206)					
b.f.o. "ON" B40/A - MANUAL B40B/C/D - TUNE	Anode	480	170	145	195
	Screen	480	23	20	26
b.f.o. "OFF" (SYSTEM SW. to R/T)	Anode	480	185	155	205
	Screen	480	40	33	47
	Cathode	120	9	7	11
SYSTEM Switch to CAL	Anode	480	105	90	120
	Screen	480	73	60	86

LOCAL OSCILLATOR OUTPUTTest Equipment required

45.

- (a) Valve Voltmeter, CT54, A.P.67921.
Set to measure a.c. volts, 24 volts range.

Connections

- (b) The probe connector of the CT54 need not be used.
Connect the valve voltmeter between the oscillator grid of the mixer valve (Pin 4 B40/A/B/C, Pin 7 B40D), and earth.

RF Voltage

- (c) The RF voltage measured should approximate to the values given below ± 1 volt.

Band	Frequency (Mc/s)	Nominal RF voltage
1	0.67	6.5 volts
2	1.66	6 "
3	4.1	7 "
4	9.8	6 "
5	18	4 "

VALVE ELECTRODE POTENTIAL TABLES - B40D

Voltage Checks

46. The following series of measurements have been taken with a d.c. 20 000 ohm/volt meter (Avometer Model 8 A.P.12945); they are average values and should only be considered as a guide to the proper functioning of a particular valve. The figures were taken whilst the receiver was delivering an output of 500 milliwatts.

(a) RF Unit

Valve Type Position	Valve Electrode	Avometer Model 8	
		P.D.	Range
V101 CV4014 1st RF valve	Anode	223	1000
	Screen	223	1000
	Cathode	61	250
V102 CV454 2nd RF valve	Anode	120	250
	Screen	59	250
	Cathode	0.6	2.5
V103 CV2128 F.C. valve	Anode	257	1000
	Screen	60	250
	Cathode	1.6	10
V104 CV4014 L.O. valve	Anode	149	250
	Screen	149	250

(b) IF Unit(i) Amplifier

Valve Type Position	Valve Electrode	Avometer Model 8	
		P.D.	Range
V201 CV131 1st IF valve	Anode Screen Cathode	257 168 2.4	1000 250 10
V202 CV131 2nd IF valve	Anode Screen Cathode	257 108 2.4	1000 250 10
V203 CV131 3rd IF valve	Anode Screen Cathode	238 166 2.2	1000 250 10
V204a CV140 A.G.C. valve	Cathode Delay Voltage	10.8	25

These measurements are taken with the grid of V206 connected to earth through $0.01 \mu\text{FD}$ capacitor (B.F.O. not oscillating).

(ii) B.F.O.

Valve Type Position	Valve Electrode	Avometer Model 8	
		P.D.	Range
V206 CV131 B.F.O. valve			
Position 1-5 of SW S202	Anode Screen	205 53	250 250
Position 6 (R/T of SW S202)	Anode Screen Cathode	231 168 10	1000 250 25
Position 7 (CAL) of SW S202	Anode Screen	130 150	250 250

(c) AF and Power Unit

Valve Type Position	Valve Electrode	Avometer Model 8	
		P.D.	Range
V301	Anode	50	100
CV454	Screen	33	100
AF Amp valve	Cathode	0.63	2.5
V302	Anode	245	1000
CV2136	Screen	224	1000
AF Output valve	Cathode	10.5	25
R305 Tapping Point 'Gain' control fully anti-clockwise		25	100

(d) H.T. Outputs from Power Unit

Point of Output	Avometer Model 8	
	P.D.	Range
SK301 Pin 1	277	1000
" " 7	253	"
" " 4	229	"
" " 2	150	250

PART B

PERFORMANCE TESTS MORE SUITABLE FOR USE IN DEPOT SHIPS AND DOCKYARDS

SIGNAL + NOISE/NOISE RATIO, AND OVERALL SENSITIVITY

Test Equipment required

47.

Instrument	Title	A.P.	Remarks
Signal Generator covering 500 kc/s to 30 Mc/s	CT218 Marconi	10S/16780 54704/A	<u>Note:-</u> This instrument is not calibrated above 25 Mc/s.
Output Wattmeter with Connector (see para. 16)	Decibel Meter Portable No. 3 Output Power Meter TF340	ZD00022 54708	
Attenuator	-	63693	These two items are required for use with A.P.54704 Signal Generator
Connector	-	63691	
Connector	-	64960	Required for use with CT218. Part of Box Stowage for connectors for CT82 Noise Generator

Test Requirement

48. (a) SENSITIVITY 500 mV output for not more than 1 microvolt input.
 (b) SIGNAL + NOISE/NOISE RATIO Better than 22 dB.

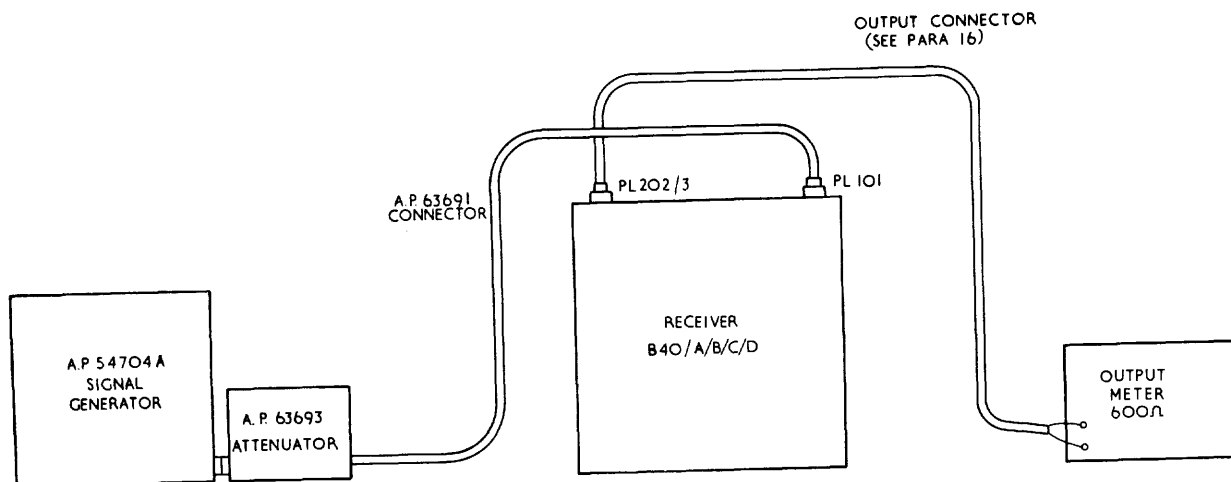

⊙ WHEN USING A.P. 54704 SIGNAL GENERATOR

FIG 3(a)

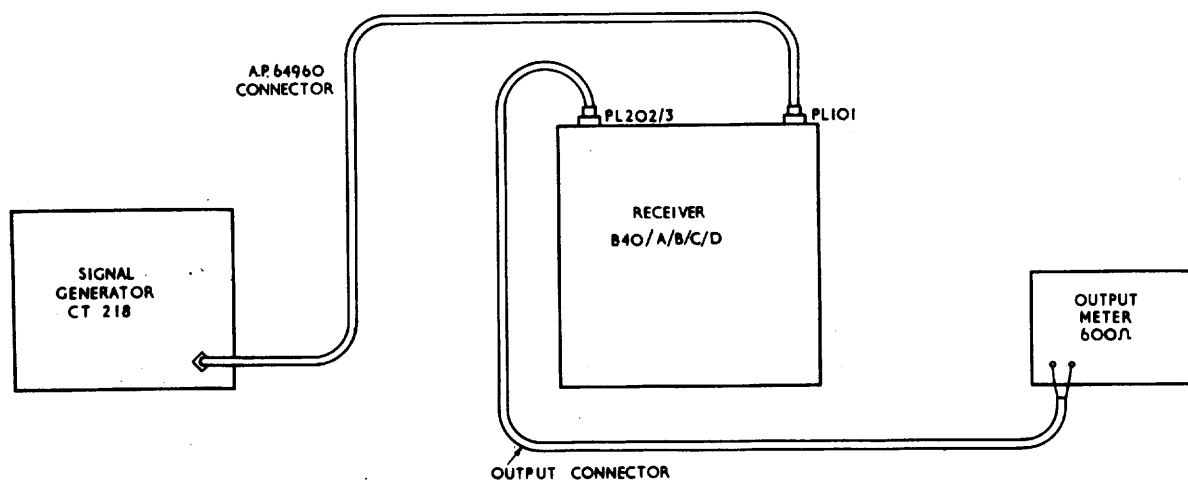

b) WHEN USING 105/16780 SIGNAL GENERATOR C.T. 218

TEST EQUIPMENT CONNECTION DIAGRAM FIG. 3(b)

The Drill

49. STEP

PROCEDURE

- 1 Connect the instruments as shown in Figs. 3a or 3b above. Switch on, and allow to warm through for 15 mins.
- 2 Set the receiver controls as follows:-
 - (1) ANTI-CROSS-MOD. control fully clockwise
 - (2) CRYSTAL switch to OFF
 - (3) LIMITER switch to OFF
 - (4)

RECEIVER	BANDWIDTH SWITCH	SYSTEM SWITCH	A.G.C. SWITCH
B40/A	Narrow	Manual [‡]	-
B40B/C	3 kc/s	R/T	OFF
B40D	3 kc/s	R/T	OFF.

- (5) OUTPUT switch towards back of receiver. Short circuit R223.

[‡] Stop h.f.o. oscillating by connecting a 0.01 μ F capacitor between the chassis and the grid of the b.f.o. valve.

STEPPROCEDURE

- (6) LOUDSPEAKER switch to OFF
- (7) TELEPHONES unplugged
- (8) AF GAIN control fully clockwise (RV224)
- (9) GAIN control fully clockwise (RV305/309)
- (10) TUNE the receiver to 0.67 Mc/s

- 3 Set the relevant signal generator controls in accordance with its Handbook instructions to provide the following:-

$$\text{MODULATION} - \begin{cases} \text{CT218} - 1000 \text{ c/s, } 30\% \\ \text{A.P.54704A} - 400 \text{ c/s, } 30\% \end{cases}$$

Output frequency 0.67 Mc/s

Output level 10 microvolts (A.P.54704A)
 1 microvolt (CT218)

- 4 Set the output meter controls to provide the following:-

Input impedance - 600 ohms

Output level - to read at least 500 mW.

- 5 Tune the signal generator accurately to the receiver setting as indicated by maximum reading in the output meter. The receiver output must exceed 500 mW.

NOTE:- If it is not possible to obtain this output, sensitivity is low, and the reason must be investigated.

- 6 Reduce receiver gain by means of the GAIN control (RV305/309) if necessary, until 500 mW is obtained.
- 7 SYSTEM switch to TUNE. B4O/A only - unclip capacitor shorting grid of b.f.o. valve to chassis. Remove short circuit from R223.

Switch off signal generator modulation i.e. to C.W.

- 8 Tune signal generator for zero beat.

- 9 B4O/A/B/C SYSTEM switch to LOW. B4OD - SYSTEM switch to FSK NARROW LOW.

- 10 Adjust receiver AF GAIN control (RV224) for a reading of 500 mW in the output meter.

- 11 Switch off the signal generator carrier, but retain all the connections to the receiver.

STEPPROCEDURE

- 12 Check that the output meter reading has fallen by at least 22 dB, i.e. to less than 3 milliwatts.
- 13 Repeat the above procedure on the following frequencies:-

BAND	Frequency (Mc/s)		
	Bottom	Middle	Top
1	0.67	1.05	1.52
2	1.66	2.6	3.8
3	4.11	6.4	9.2
4	9.8	13.1	17.4
5	18.0	23.0	28.0

OVERALL AUDIO-FREQUENCY RESPONSETest Equipment required

50.

Description	Identity	A.P.
Signal Generator covering 1 Mc/s with provision for external modulation	CT218 Marconi	10S/16780 54704/A
Audio frequency variable frequency Oscillator	G.205	W.7252
Output Meter with Connector (see para. 16)	Decibel Meter Portable No. 3 TF340	ZD.00022 54708
Attenuator	-	63693
Connector		63691
Connector	-	64960

NOTE 1:- These will be required if A.P.54704/A Signal Generator is used.
For details see paras. 11 to 13.

NOTE 2 :- Required if CT218 Signal Generator is used. Provided in the
"Box Stowage for connectors for CT82 Noise Generator".

Test requirement

51. The audio frequency response, measured at the receiver output, with the signal fed to the receiver input, should conform to the following requirements:-
- (a) With a reference level established at the maximum output obtainable over the audio-frequency range, the output at 300 c/s and 3000 c/s modulation should not fall by more than 4 dB below the reference level.
 - (b) The output at 80 c/s modulation frequency should fall by at least 18 dB below the reference level.

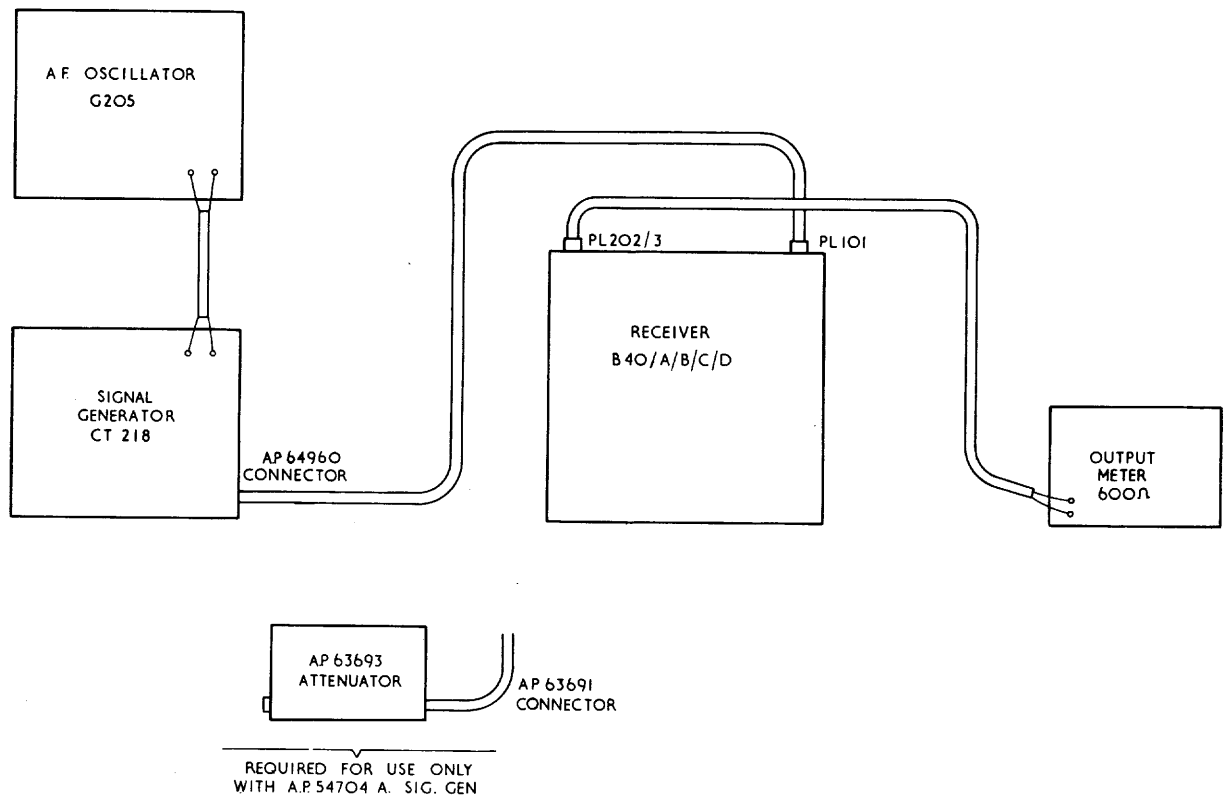

TEST EQUIPMENT CONNECTION DIAGRAM FIG 4

The Drill

52. STEP

PROCEDURE

1 RECEIVER controls as follows:-

- (1) ANTI-CROSS-MOD. control fully clockwise
- (2) CRYSTAL switch to OFF
- (3) LIMITER switch to OFF
- (4) OUTPUT switch, toggle to rear of receiver
- (5) LOUDSPEAKER switch to OFF
- (6) GAIN control fully clockwise (RV305/309)
- (7) TUNE to 1.05 Mc/s
- (8)

RECEIVER	BANDWIDTH SWITCH	SYSTEM SWITCH	A.G.C. SWITCH
B40/A	Wide	Tune	-
B40B/C/D	8 kc/s	Tune	OFF

2 Signal generator

- (1) Adjust output level to 10 microvolts, (100 microvolts in the case of A.P.54704/A).
- (2) TUNE to 1.05 Mc/s (the receiver frequency) and adjust carefully for MINIMUM output meter reading i.e. zero beat.

3 SYSTEM switch to R/T (B40B/C/D). SYSTEM switch to MANUAL (B40/A) and stop b.f.o. oscillating by connecting 0.01 μ F capacitor between b.f.o. valve grid and chassis.

4 Signal generator to external modulation. Adjust modulation frequency of external AF Oscillator for maximum receiver output, maintaining modulation depth at 30%.

5 Adjust receiver gain by means of the AF GAIN control (RV224) for a reading of +15 dB on the 10 milliwatts output meter range i.e. 316 milliwatts. This is the reference level.

STEPPROCEDURE

- 6 Maintaining the modulation depth at 30%, vary the AF modulation frequency in steps between 80 c/s and 3000 cycles per second.

Check that:-

- (1) The output meter reading does not fall more than 4 dEs below the +15 dB reference level at any modulating frequency between 300 c/s and 3000 c/s, i.e. it must not fall below 125 milliwatts.
- (2) The output meter reading falls more than 18 dB below the +15 dB reference level, i.e. below 5 mW, at a modulating frequency of 80 cycles per second.

OUTPUT LEVELSTest equipment required

53.
(a)

Description	Identity	A.P.
Signal Generator covering approximately 1 Mc/s	CT218 Marconi	10S/16780 54704/A
Output Meter with Connector (see para. 16)	Decibel Meter Portable No. 3 TF340	ZD.00022 54708
Connector } Attenuator }	See Note 1	63691
		63693
Connector	See Note 2	64960

NOTE 1.- Required for use with A.P.54704/A Signal Generator

NOTE 2:- " " " " CT218 " "

- (b) To facilitate this test a special output connector should be made up. It consists of a six way Mark 4 socket (see Chapter 8 Para. 18) with three twisted pairs suitably coloured for identification, about 4 ft long. The three pairs are connected to Pins A and B, C and D, and E and F, the free ends being fitted with either spade terminals or crocodile clips. Chapter 8 gives information on how to assemble this socket connector and details concerning approved methods of soldering to the pins.

(c) A further connector is required for Step 5 of the test to connect the output meter to the phone jack. This consists of a standard phone jack plug terminating a twisted pair about 3 feet long. Spade terminals or crocodile clips are connected to the free ends.

Test requirement

54. When the receiver is set up to give 500 mW at the external loudspeaker pins of the output socket, the levels at the other outputs should be as follows:-

Output Socket pins for LINE	- 5 milliwatts	} ± 1.5 dB
" " " " PHONES	- 3.5 milliwatts	
Phone Jack 1	3.5 milliwatts	
Phone Jack 2	3.5 milliwatts	

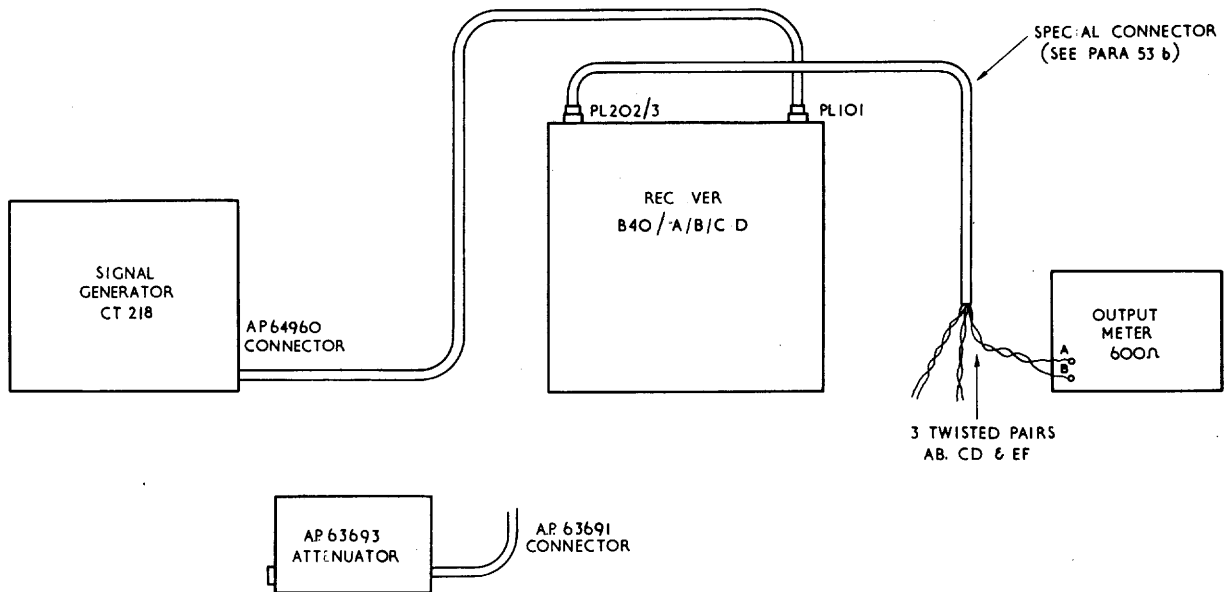

REQUIRED FOR USE ONLY
WITH AP 54704A SIG. GEN.

TEST EQUIPMENT CONNECTION DIAGRAM FIG. 5

The Drill55. STEPPROCEDURE

1

RECEIVER controls as follows:-

- (1) ANTI-CROSS-MOD. control - fully clockwise
- (2) CRYSTAL switch - OFF
- (3) LIMITER switch - OFF
- (4) OUTPUT switch (at back of receiver) - Toggle to rear of receiver
- (5) LOUDSPEAKER switch - OFF
- (6) GAIN control - fully clockwise
- (7)

RECEIVER	BANDWIDTH SWITCH	SYSTEM SWITCH	A.G.C. SWITCH
B40/A	Narrow	R/T	-
B40B/C/D	3 kc/s	R/T	ON

- (8) TUNE to 1.05 Mc/s

2

Signal Generator controls as follows:-

- (1) Modulation, 1000 c/s (CT218) or 400 c/s (54704/A) 30% depth of modulation.
- (2) Tune to 1.05 Mc/s, and adjust for maximum reading in the output meter.
- (3) Output level - 100 microvolts (A.P. 54704/A)
10 microvolts (CT218)

3

With the output meter connected to pins A and B of the special connector described in para. 53(b), adjust receiver AF GAIN control for a reading of 500 mW in the meter.

4

Put the toggle of the output switch towards the front of the receiver. Disconnect output wattmeter from pins A and B of PL203/2, and connect it in turn, by means of the special connector, to pins C and D (600 ohms line) and E and F (600 ohms 'phones). An output power reading of 5 mW for "Line" and 3.5 mW for "phones" (+ 1½ dB) should be obtained.

NOTE:- Pins A and F should be connected to the earth terminal of the output meter. When testing the output across pins C and D, no particular connection is required.

5

Plug in the output meter in turn to each of the telephone jacks on the front panel, using the connector described in para. 53(c). With the wattmeter set to 600 ohms an output power reading of 3.5 mW + 1½ dB should be obtained from each jack.

IMAGE REJECTION

Test Equipment required

56.

Description	Identity	A.P.
Signal Generator covering 1 Mc/s to 25 Mc/s	CT218 Marconi	10S/16780 54704/A
Output Meter with Connector (see para. 16)	Decibel Meter Portable No. 3 TF340	ZD.00022 54708
Attenuator	-	63693
Connector	-	63691
Connector	-	64960

NOTE 1:- These will be required if A.P.54704/A Signal Generator is used.

NOTE 2:- Required if CT218 Signal Generator is used. Provided in the "Box Stowage for connectors for CT82, Noise Generator".

Test requirement

57. The image rejection should be as follows:-

Wave-Band	Fundamental Frequency (Mc/s)	Image Frequency (Mc/s)	Image Rejection (dB)
1	1.05	2.05	Exceeding 95 dB
2	2.6	3.6	" 80 "
3	6.4	7.4	" 60 "
4	13.1	14.1	" 50 "
5	23	24	" 40 "

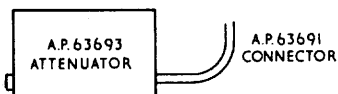
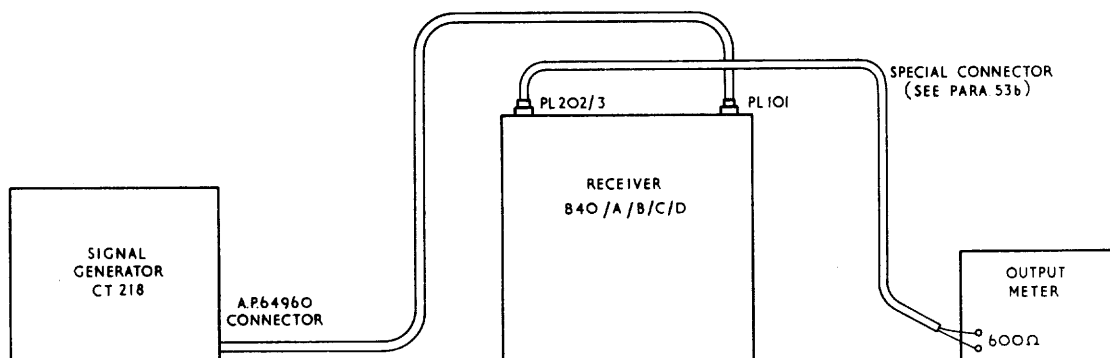

REQUIRED FOR USE ONLY
WITH A.P.54704A SIG. GEN.

TEST EQUIPMENT CONNECTION DIAGRAM FIG. 6

The Drill

58. STEP

PROCEDURE

1

RECEIVER controls as follows:-

- (1) ANTI-CROSS-MOD. control - fully clockwise
- (2) CRYSTAL switch - OFF
- (3) LIMITER switch - OFF
- (4) OUTPUT switch - toggle toward rear of receiver
- (5) LOUDSPEAKER switch - OFF
- (6) GAIN control - fully clockwise
- (7) TUNE to 1.05 Mc/s

(8)

RECEIVER	BANDWIDTH SWITCH	SYSTEM SWITCH	A.G.C. SWITCH
B40/A	Narrow	Manual	-
B40B/C/D	3 kc/s	R/T	OFF

N.B. B40/A - connect grid of b.f.o.

STEPPROCEDURE

- 2 Signal Generator controls:-
 - Output tuned to receiver setting of 1.05 Mc/s.
 - Output modulated 30%, 1000 c/s (CT218) or 400 c/s (A.P.54704/A)
 - Output level - 10 microvolts for A.P.54704/A Signal Generator
1 microvolt for CT218 Signal Generator
 - 3 Receiver AF GAIN control (RV224), adjust for 500 mV reading in output meter.
 - 4 Tune signal generator to 2.05 Mc/s. Increase the signal generator output by a substantial amount (e.g. by approximately the number of decibels shown in the "image rejection" column under "Test requirement". Vary the signal generator tuning around 2.05 Mc/s until the image frequency is tuned exactly, as shown by a rise in output meter reading. Adjust the signal generator accurately to this setting.
 - 5 Re-adjust the signal generator output level until the output meter reading is again 500 mV.
 - 6 Check that the signal generator output level is now greater than its original setting by 95 dB or more.
 - 7 Repeat the procedure for the other frequencies listed in the table under "Test requirement", and check that the appropriate image rejection figure in decibels is obtained.
- N.B. When A.P.54704/A signal generator is used, the result is not always accurate, due to the mismatch which occurs when the attenuator is switched to "mV x 100".

A.G.C. PERFORMANCETest equipment required

59.

Description	Identity	A.P.
Signal Generator covering around 1 Mc/s	CT218 Marconi	10S/16780 54704/A
Output Meter with Connector (see para. 16)	Decibel Meter Portable No. 3 TF340	ZD.00022 54708
Attenuator	-	63693
Connector	-	63691
Connector	-	64960

NOTE 1:- These will be required if A.P.54704/A Signal Generator is used.

NOTE 2:- Required if CT218 Signal Generator is used. Provided in the "Box Stowage for connectors for CT82 Noise Generator".

Test requirement

60. The receiver is adjusted to give a 200 mW output with a 1.5 microvolt input. Modulation is 30%, 1000 c/s (CT218) or 400 c/s (A.P.54704/A). The input at the receiver is increased from 1.5 microvolt to 10 millivolts (i.e. by 77 dB). The receiver output should not change by more than 3.5 dB at any point between the two input voltage levels.

N.B. When using A.P.54704/A Signal Generator, the output attenuator should be set to 15 microvolts and 100 millivolts respectively, due to the use of the Attenuator A.P.63693.

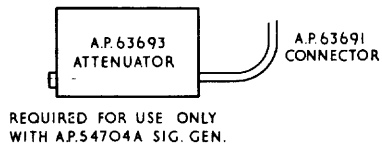
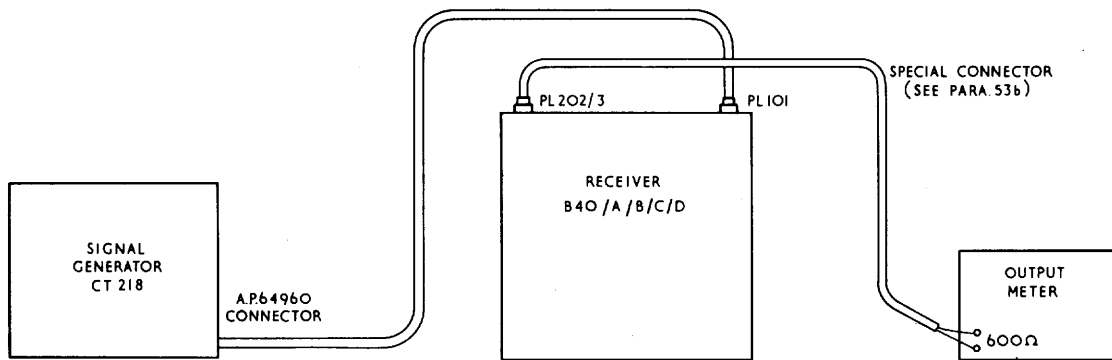

TEST EQUIPMENT CONNECTION DIAGRAM

FIG. 7

The Drill

61. STEP

PROCEDURE

1

RECEIVER controls as follows:-

- (1) ANTI-CROSS-MOD. control - fully clockwise
- (2) CRYSTAL switch - OFF
- (3) LIMITER switch - OFF
- (4) OUTPUT switch at back of receiver - toggle toward back of receiver
- (5) LOUDSPEAKER switch - OFF
- (6) GAIN control - fully clockwise
- (7) TUNE to 1.05 Mc/s
- (8)

RECEIVER	BANDWIDTH SWITCH	SYSTEM SWITCH	A.G.C. SWITCH
B40/A	Narrow	R/T	-
B40B/C/D	3 kc/s	R/T	CN

STEPPROCEDURE

- 2 Signal Generator controls:-
- (1) Output level - 1.5 microvolt (CT218)
15 microvolts (A.P.54704A)
- (2) Modulation - 30%, 1000 c/s (CT218) or 400 c/s
(A.P.54704/A)
- (3) Frequency - tune to receiver frequency of 1.05 Mc/s,
as indicated by maximum output meter
reading.
- 3 Adjust receiver AF GAIN control (RV224) to give a reading of
200 milliwatts in the output meter.
- 4 Slowly increase the signal generator output voltage in
convenient steps 6700 times, i.e. by 77 dB (CT218, to
10 millivolts, A.P.54704A to 00 millivolts).
Check that output meter reading does not increase by more
than 3.5 dB at any point between the two voltage output
limits.

ANTI-CROSS-MODULATIONTest Equipment required

62.

Description	Identity	A.P.
Signal Generator covering around 1 Mc/s	CT218 Marconi	10S/16780 54704/A
Output Meter with Connector (see para. 16)	Decibel Meter Portable No. 3 TF340	ZD.00022 54708
Attenuator } Connector } See Note 1	-	63693
	-	63691
Connector See Note 2	-	64960

NOTE 1:- These will be required if A.P.54704/A Signal Generator is used.

NOTE 2:- Required if CT218 Signal Generator is used. Provided in the
'Box Stowage for connectors for CT22 No se Generator'.

Test requirement

- 63.
- (a) With the ANTI-CROSS-MODULATION control fully clockwise (maximum gain position) receiver gain is adjusted so that with an input of 100 microvolts (CT218) or 1 millivolt (A.P.54704/A), an output of 500 milliwatts is obtained.
 - (b) Turn the ANTI-CROSS-MODULATION control fully anti-clockwise. Increase the output of the signal generator until the output meter again reads 500 mW, and check that the signal generator output is now at least 15 dB greater than in (a) i.e. 560 microvolts (CT218) or 5.6 millivolts (A.P.54704/A).

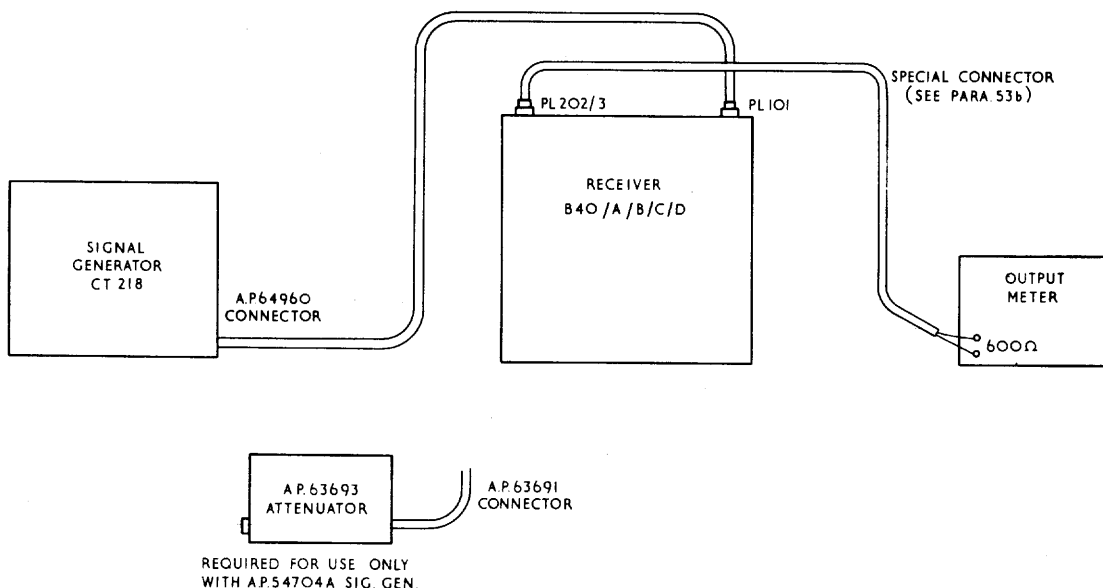

TEST EQUIPMENT CONNECTION DIAGRAM

FIG. 8

The Drill

64. STEP PROCEDURE
- 1 RECEIVER controls as follows:-
 - (1) ANTI-CROSS-MOD. control - fully clockwise
 - (2) CRYSTAL switch - OFF

STEPPROCEDURE

- (3) LIMITER switch - OFF
- (4) LOUDSPEAKER switch - ON
- (5) AF GAIN control - fully clockwise (RV224)
- (6) TUNE to 1.05 Mc/s

(7)

RECEIVER	BANDWIDTH SWITCH	SYSTEM SWITCH	A.G.C. SWITCH
B4O/A	Narrow	Manual	-
B4OB/C/D	3 kc/s	Tune	OFF

(8) OUTPUT switch at rear of receiver, toggle to rear of set.

2 Signal Generator controls as follows:-

(1) Tune to 1.05 Mc/s, unmodulated, exactly to zero beat as indicated by zero output meter reading.

(2) Output to 100 microvolts (1 millivolt A.P.54704/A Sig. Gen.)

3 SYSTEM switch to:-

B4O/A - Manual, but detune receiver for maximum "audio" output.

B4OB/C - LOW

B4OD - FSK NARROW LOW

Adjust GAIN control (RV305/309) for a reading of 500 milliwatts in the output meter.

4 ANTI-CROSS-MOD. control fully anti-clockwise.

5 Increase signal generator output until output meter again reads 500 mW.

6 Check that signal generator output has increased by at least 15 dB i.e. at least 560 microvolts, or 5.6 millivolts, depending upon the signal generator employed.

CRYSTAL CONTROLLED OPERATION

Test Equipment required

65.

Description	Identity	A.P.
Signal Generator covering 2 Mc/s - 10 Mc/s	CT218 Marconi	10S/16780 54704/A
Connector - See Note	-	64960

NOTE:- Provided with connectors for CT82 Noise Generator.

Test requirement

66. With a suitable crystal of frequency F_c plugged in, the receiver should operate, crystal controlled, at $n.F_c = 500$ kc/s, where n is 1, 2, 3 or 4 e.g. $F_c = 2.5$ Mc/s.

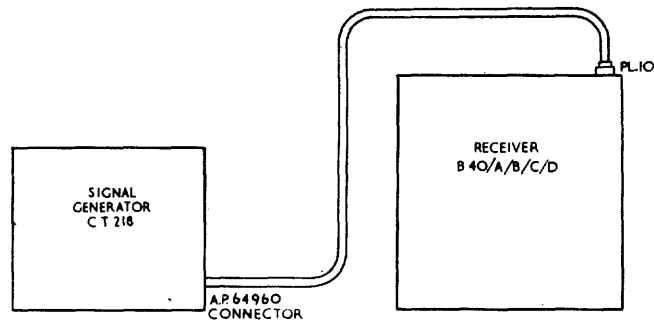

TEST EQUIPMENT CONNECTION DIAGRAM FIG. 9

The Drill

67. STEP

PROCEDURE

- 1 RECEIVER controls as follows:-
- (1) ANTI-CROSS-MOD. control - fully clockwise
 - (2) CRYSTAL switch - to ON. Note that warning lamp should work.

STEPPROCEDURE

- (3) Plug-in a crystal of any frequency, e.g. 2.5 Mc/s
- (4) OUTPUT switch at back of receiver - toggle towards front of receiver
- (5) LIMITER switch - OFF
- (6) LOUDSPEAKER switch - to ON
- (7) GAIN controls - adjust for adequate loudspeaker output.
- (8)

RECEIVER	BANDWIDTH SWITCH	SYSTEM SWITCH	A.G.C. SWITCH
B40/A	Narrow	Manual	-
B40B/C/D	3 kc/s	Tune	OFF

2 Signal Generator controls:-

- (1) C.W. operation
- (2) Output level - 10 microvolts (A.P.54704A)
- 1 microvolt (CT218)
- (3) Tune to F_c - 500 kc/s (2000 kc/s)

3 Tune receiver to F_c - 500 kc/s (2000 kc/s) then tune signal generator to receiver frequency as indicated by maximum volume in the loudspeaker. Tune the receiver around this frequency and check that a note is obtained, which varies in amplitude but not in pitch. The receiver is then operating crystal controlled.4 Repeat the operation at twice, three and four times the crystal frequency (2, 3 and 4 F_c - 500 kc/s). Using the crystal quoted this would be at 4.5 Mc/s, 7 Mc/s and 9.5 Mc/s.

NOISE LIMITER ACTION

Test Equipment required

68.

Description	Identity	A.P.
Signal Generator covering around 0.67 Mc/s	CT218 Marconi	10S/16780 54704A
Oscilloscope	-	10S/831
Attenuator	-	63693
Connector		
Connecting lead with attenuator. As supplied with CT218 See Note 2	-	
Connector consisting of a phone jack (A.P.650/1) connected to a twisted pair (see para. 53(c)).		

NOTE 1:- This will be required if A.P.54704A Signal Generator is used.

NOTE 2:- This will be required for use with CT218.

Test requirement

69. When a signal of 200 μ V (CT218) or 1000 μ V (A.P.54704A) modulated at 1000 or 400 c/s, the modulation depth being any value between 10% and 60%, is applied to the mixer valve grid, the limiter control is effective in its limiting action.

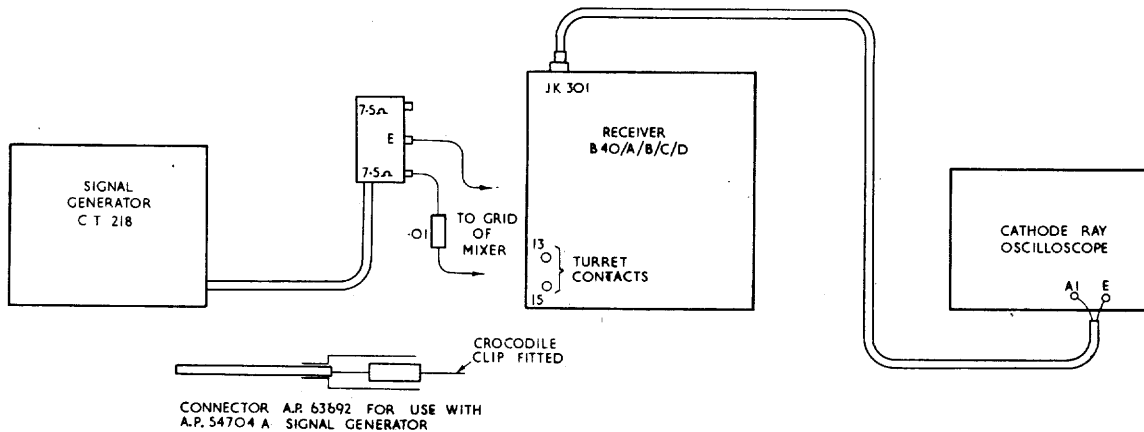

TEST EQUIPMENT CONNECTION DIAGRAM

FIG. 10

The Drill70. STEPPROCEDURE

- 1 Set RECEIVER controls as follows:-
- (1) CRYSTAL switch - ON. Remove crystal
 - (2) SYSTEM switch - R/T
 - (3) LIMITER switch - OFF
 - (4) OUTPUT switch at back of receiver, toggle towards rear of receiver.
 - (5) LOUDSPEAKER switch - OFF
 - (6) GAIN control - to give suitable amplitude of trace without distortion
 - (7) AF GAIN control - fully clockwise
 - (8) TUNE to 0.67 Mc/s.
 - (9)

RECEIVER	BANDWIDTH SWITCH	A.G.C. SWITCH
B4O/A	Wide	-
B4OB/C/D	8 kc/s	ON

- 2 Set Signal Generator controls as follows:-

Frequency - 500 kc/s

Modulation - CT218, 1000 c/s
A.P.54704A, 400 c/s

Modulation Depth - 10%

Output level - 1000 microvolts A.P.54704A
200 microvolts CT218

Connect output via a 0.01 μ F capacitor (already incorporated in A.P.54704A Signal Generator lead) to the receiver mixer grid.

- 3 Set oscilloscope controls as follows:-

Trig. Sync. to Y1

Velocity range - 100 c/s

Fine velocity - suitable value

Y Plate selector - A1, A2

STEPPROCEDURE

- 4 Tune the signal generator exactly to the receiver IF as shown by maximum height of trace on the c.r.t. Adjust the oscilloscope "Y" plate amplifier control for a convenient height of trace.
- 5 Switch the receiver LIMITER switch to "ON". Check that the LIMITER control is effective, as indicated by a reduction in the amplitude of the trace on the c.r.t., when the limiter control is operated.
- 6 By steps, increase the modulation depth up to a maximum of 60%, checking the effectiveness of the LIMITER control at each step.

AF GAINTest Equipment required

71.

Description	Identity	A.P.
Audio Frequency Test Oscillator capable of operating at 1 kc/s	G.205	W.7252
Output Meter	Decibel Meter Portable No. 3 TF340	ZD.00022 54708

Special Items

72. A 100/1 voltage divider should be made up as follows:-

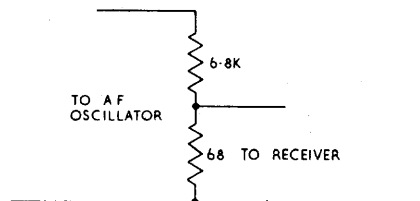

100/1 VOLTAGE DIVIDER

FIG. 11

Test requirement

73. For a receiver output of 500 milliwatts, the input to the grid of the first AF valve should be not greater than 0.15 volts, at 1000 c/s.

NOTE 1:- With the test equipment connected as shown, the output voltage at the AF oscillator should be 15 volts.

NOTE 2:- It is necessary to remove the AF and Power Unit from the receiver in order to carry out this test.

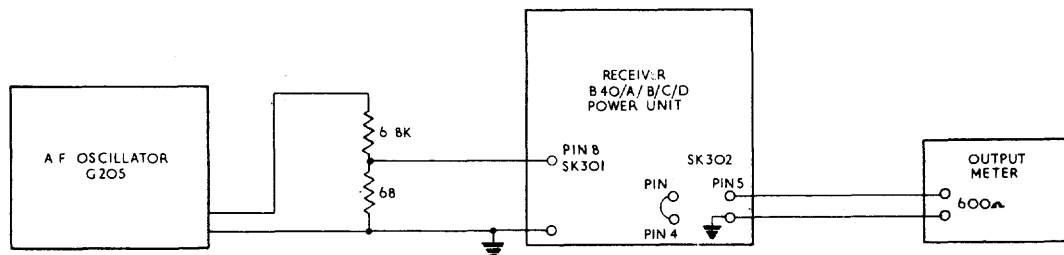

TEST EQUIPMENT CONNECTION DIAGRAM

FIG. 12

The Drill74. STEPPROCEDURE

- 1 Remove the AF and Power Unit from the receiver. Reconnect the mains plug. Connect up the test equipment.
- 2 On all patterns of the receiver, connect pins 1 and 9 of SK302.
- 3 On B40/A, connect pins 5 and 6 of SK301.
- 4 Switch on, and allow 15 minutes to warm through.
- 5 AF oscillator frequency, 1000 c/s.
- 6 Adjust the AF oscillator output level so that the output meter reads 500 milliwatts. The oscillator output should be not more than 15 volts.

IF RESPONSE

ADJACENT CHANNEL SELECTIVITY

METHOD USING SIGNAL GENERATOR, AF OSCILLATOR AND OUTPUT METER

Test Equipment required

75.

Instrument	Title	A.P.
Signal Generator covering 500 kc/s	CT218 Marconi	10S/16780 54704/A
Output Wattmeter with Output Connector (Para. 16)	Decibel Meter Portable No. 3 Output Power Meter TF340	ZD.00022 54708
AF Oscillator	-	W.7252
Model 8 Avometer	-	A.P.12945
Attenuator	-	63693
Connector See Note	-	63692

NOTE:- For use with A.P.54704/A Signal Generator

Additional equipment

- 76.(a) A 0.01 mfd capacitor with a crocodile clip on each lead. (B40/A only).
(b) A coaxial plug (A.P.60046) connected to a suitable length of coaxial cable (see Chap. 6, Para. 6).

Test requirement

77. The minimum acceptable bandwidth at 6 dB down, and the maximum acceptable bandwidth at 40 dB down for each position of the BANDWIDTH switch is as follows:-

Response Level	Receiver B40/A		Receiver B40B/C/D		
	Narrow	Wide	1 kc/s	3 kc/s	8 kc/s
6 dB (min.)	2.5 kc/s	8 kc/s	1 kc/s	2.5 kc/s	8 kc/s
40 dB (max.)	9 kc/s	25 kc/s	$\frac{1}{5}$ kc/s	9 kc/s	25 kc/s

$\frac{1}{5}$ = "1 kc/s position" measured at 30 dB down

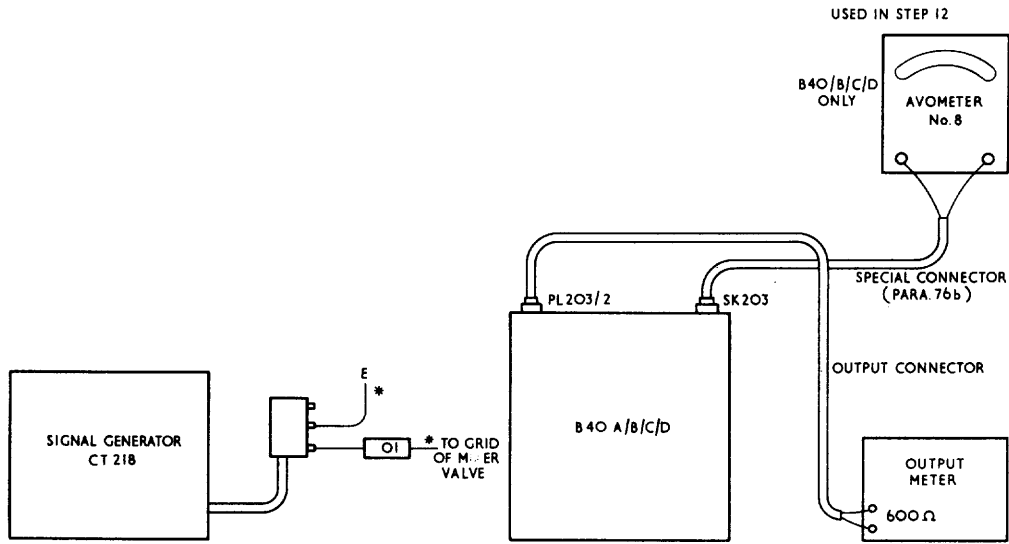

NOTE:- IF A P.54704 A SIGNAL GENERATOR IS USED, THE CONNECTION BETWEEN THE SIGNAL GENERATOR AND THE GRID OF THE MIXER VALVE IS MADE THROUGH THE A.P.63693 ATTENUATOR AND A.P.63692 CONNECTOR.

* CROCODILE CLIPS FITTED.

FIG. 13(a)
TEST EQUIPMENT CONNECTION DIAGRAM

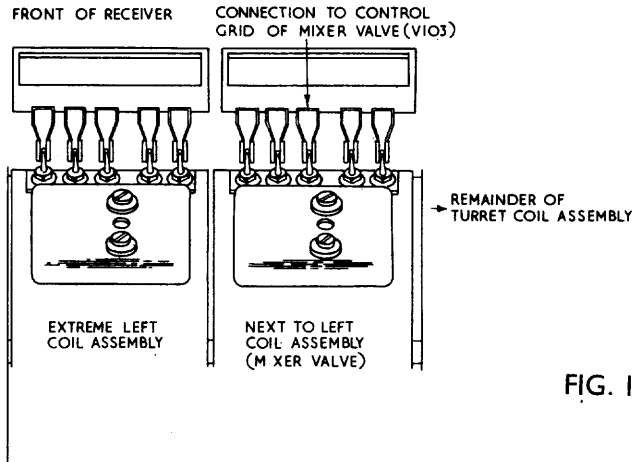

FIG. 13(b)

The Drill

78. STEP

PROCEDURE

1

Receiver settings as follows:-

OUTPUT switch towards rear of receiver

ANTI-CROSS-MOD. control fully clockwise

STEPPROCEDURE

CRYSTAL switch ON, crystal removed

A.G.C. switch to OFF

NOISE LIMITER to OFF

LOUDSPEAKER switch to ON

GAIN and AF GAIN controls fully clockwise

SYSTEM switch to TUNE

BANDWIDTH switch to NARROW or 3 kc/s

TUNE receiver to 0.67 Mc/s

2 Calibrate the signal generator incremental or logging scale as follows:-

(a) A.P.54704/A - follow the instructions contained in the Signal Generator Handbook, or use a method similar to that given below.

(b) CT218

- (1) Set the signal generator output to approximately 50 microvolts, and connect to mixer grid, no modulation.
- (2) Tune the signal generator accurately for zero beat at 500 kc/s as indicated by the output meter. Note the logging scale reading, and identify this reading as (A).
- (3) Increase the signal generator frequency until the audio note is approximately 1000 c/s.
- (4) Receiver SYSTEM switch to R/T.
Signal generator to modulate 30% at 1000 c/s.
- (5) Compare the 1000 c/s note with the audio note heard in (3) above.
- (6) Switch off signal generator modulation. SYSTEM switch to TUNE. Adjust the signal generator frequency and repeat steps 4 and 5 as necessary until the two notes are equal in pitch.
- (7) Note the logging scale reading, and identify this reading as (B).

The difference between readings (A) and (B) represents 1000 c/s (1 kc/s).

Greater accuracy can be achieved by repeating the procedure with the signal generator 1 kc/s below the zero beat frequency (see (3) above), and taking an average of the two results.

STEPPROCEDURE

- 3 SYSTEM switch to CAL.
- Adjust signal generator frequency for zero beat as observed in the output meter.
- Signal generator output level to 50 microvolts (CT218) or 250 μ V (A.P.54704/A).
- 4 SYSTEM switch to TUNE
- Any note heard represents an error in b.f.o. alignment, and if this note is higher in pitch than a low "burr", the b.f.o. should be re-aligned.
- 5 Adjust the signal generator accurately for zero beat.
- 6 SYSTEM switch to R/T (B40B/C/D), MANUAL (B40/A).
In B40/A, stop b.f.o. oscillating by connecting an 0.01 μ F capacitor between b.f.o. valve grid and chassis.
- 7 Switch signal generator to modulate, 30%, CT218 - 1000 c/s
A.P.54704/A - 400 c/s
- Adjust AF GAIN to give suitable receiver output i.e. 100 milliwatts.
- 8 Increase signal generator output voltage by 6 dB i.e. from 50 microvolts to 100 microvolts (or 250 to 500 microvolts for A.P.54704/A). Detune the signal generator until the receiver output falls to the original level. Note carefully the amount of detuning on the incremental or logging scale, and convert this reading to kc/s.
- 9 Repeat, detuning the signal generator in the opposite direction. The sum of the two frequencies derived from the incremental scale readings, gives the bandwidth at 6 dB down. This should be greater than 2.5 kc/s.
- 10 Repeat steps (7) (8) and (9), but this time increase the input by 40 dB i.e. from 50 microvolts to 5 millivolts (250 μ V to 25 mV for A.P.54704/A), after detuning the signal generator so that the output meter is not damaged. Read off from the incremental scale readings, the bandwidth at 40 dB. It should be less than 9 kc/s.
- 11 Repeat steps (5) to (10) inclusive, with receiver BANDWIDTH to 8 kc/s or WIDE. In this case, the bandwidth 6 dB down should be greater than 8 kc/s, and the bandwidth 40 dB down should be less than 25 kc/s.

In the case of B40B/C/D, to check the receiver bandwidth in the 1 kc/s position, the output meter should be disconnected and a Model 8 (high resistance) Avometer connected to read second detector current. The connection of the Avometer is fully described in Chapter 6 Para. 23.3.(2) under Crystal Filter Alignment. The following procedure should be carried out using the Avometer for measuring receiver output.

- (1) With the Avometer disconnected, set receiver BANDWIDTH switch to 1 kc/s and SYSTEM switch to CAL. Switch OFF signal generator modulation, and adjust its tuning for zero beat, as heard in the monitor loudspeaker. Note the logging scale reading.
- (2) SYSTEM switch to R/T. Connect Avometer and adjust the signal input voltage to obtain a reading of 50 microamps in the Avometer (switched to the correct current range - 250 μ A). Care must be taken when using the meter to ensure that it is not damaged by overloading.
- (3) Increase the signal input voltage to twice its original setting (6 dB), and increase the signal generator frequency until the reading in the Avometer is again 50 microamps. Carefully note the amount of de-tuning on the logging scale and convert the reading to c/s.
- (4) Decrease the signal generator frequency to the setting below 500 kc/s where the Avometer again reads 50 microamps. Note the frequency on the logging scale, and convert to c/s.
- (5) The two frequencies so obtained are added together and should exceed 1 kc/s.
- (6) Tune the signal generator to 500 kc/s and repeat the procedure, but this time increase the signal input voltage 30 times (30 dB approx.). The bandwidth at this level should not exceed 5 kc/s.

Important. When making this test it is essential that the signal generator is de-tuned over 5 kc/s before making the voltage increase, both above and below 500 kc/s, to avoid damaging the meter.

IF RESPONSE (METHOD USING FREQUENCY SWEPT OSCILLATOR AND OSCILLOSCOPE)

79. For those ships and dockyards who may possess a ganging oscillator, such as the Cossor Model A.P.54707, a quicker method is available. The shape of the response curves which should be seen, is given in Fig. 15.

Test Equipment required

80.

Instrument	Title	A.P.
Frequency swept Oscillator covering 500 kc/s	Cossor Model	54707
Oscilloscope	Type 13A	10S/831

Additional equipment

81. A 0.01 μF capacitor with a crocodile clip at each end. (For use with B40/A only.)

Connectors of suitable length made up from any convenient uniradio (screened) cable.

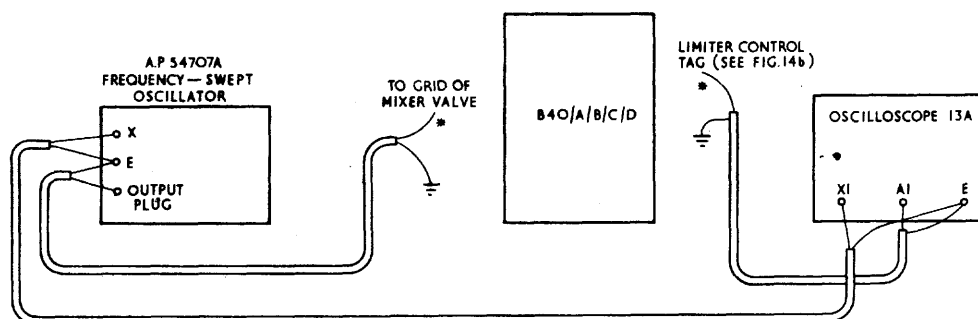

* CROCODILE CLIPS FITTED.

FIG. 14(a)
TEST EQUIPMENT CONNECTION DIAGRAM

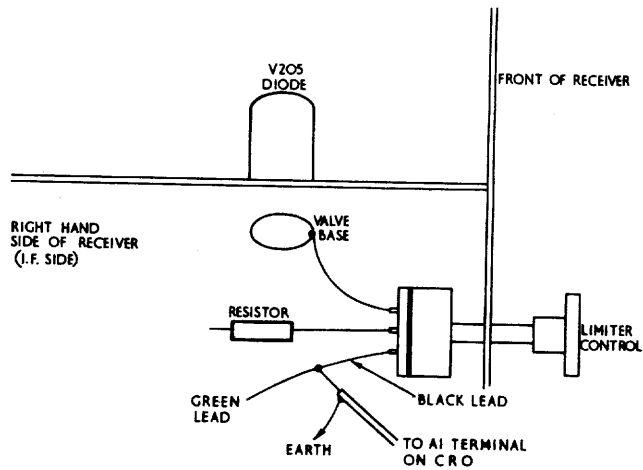

CONNECTION TO RECEIVER FROM CRO
FIG. 14(b)

The Drill

82. STEP

PROCEDURE

1

Receiver settings:-

- (1) OUTPUT switch towards front of receiver.
- (2) ANTI-CROSS MOD. control fully clockwise.
- (3) CRYSTAL switch to ON, crystal removed.
- (4) SYSTEM switch to CAL.
- (5) LOUDSPEAKER switch to OFF.
- (6) AF GAIN control fully clockwise (RV224).
- (7) GAIN control, adjust for reasonable output in the telephones.

STEPPROCEDURE

(8)

RECEIVER	BANDWIDTH SWITCH	A.G.C. SWITCH
B40/A	Narrow	-
B40B/C/D	3 kc/s	CN

(9) TUNE to 0.67 Mc/s

(10) Plug in Telephones

2 Ganging oscillator settings:-

(1) Frequency - 500 kc/s. Adjust tuning slightly until zero beat is heard in the telephones. Leave the tuning dial at this setting.

(2) Bandwidth - 20 kc/s.

3 Oscilloscope settings:-

(1) Trig. Sync. - EXT

(2) Velocity Range - 10 c/s

(3) Fine Velocity - As low as convenient

(4) Cal. Markers - OFF

(5) Y Plate Selector - A1, A2

4 SYSTEM switch B40/A - MANUAL
Short the grid of the b.f.o. valve to earth by a 0.01 μ F capacitor.
B40B/C/D - R/T

Adjust GAIN control for reasonable picture amplitude in c.r.t.

Do not overload the receiver

5 Adjust the A1 gain control on the oscilloscope to give a convenient measurable deflection on the graticule.

6 Inspect the IF response curve displayed in the c.r.t., for symmetry. Re-alignment must be undertaken if the skirts are noticeably asymmetric.

7 Measure the bandwidth across the response curve at the point where the amplitude has dropped to half the value of the centre-frequency (500 kc/s) amplitude i.e. at the 6 dB down points. The horizontal frequency scale may be calibrated by the 20 kc/s length of the oscilloscope time-base.

STEP

PROCEDURE

8 Repeat the above procedure, with the BANDWIDTH switch in the following positions:-

RECEIVER	BANDWIDTH POSITIONS
B40/A	Wide
B40B/C/D	8 kc/s 1 kc/s

The curves should be shaped similarly to those illustrated in Fig. 15. It is especially important that the 1 kc/s curve should be accurate.

9 Receivers which fail to satisfy the test should have the IF stages re-aligned.

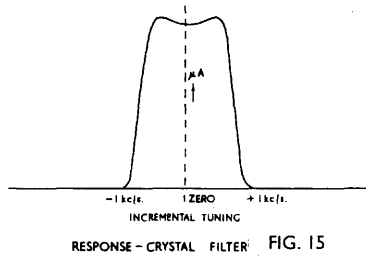
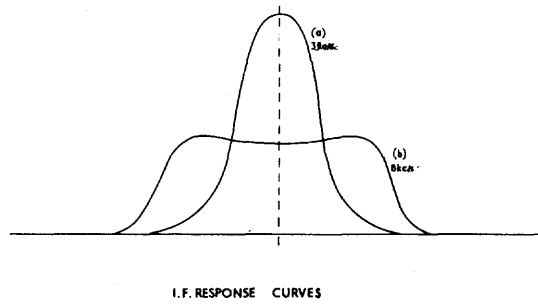

IF GAIN MEASUREMENTSPART 1OVERALL IF GAINTest Equipment required

83.

Description of instrument	Identity	A.P.
Signal Generator capable of operation at 500 kc/s, and modulation of 400 or 1000 cycles per second at 30%	CT218 Marconi	10S/16780 54704/A
Output Meter with Output Connector (see para. 16)	Decibel Meter Portable No. 3 TF340	ZD.00022 54708
Connector See Note 2	-	
Connecting lead with attenuator See Note 1	-	63692/3

NOTE 1:- This will be required if A.P.54704/A Signal Generator is used.

NOTE 2:- This is supplied with CT218 Signal Generator.

Test requirement

84. In order to produce a reading of 500 milliwatts in the output meter, a signal at 500 kc/s modulated 30%, injected by the signal generator at the grid of the mixer valve, must not exceed the following:-

BANDWIDTH SWITCH POSITION	INPUT VOLTAGE	
	CT218	A.P.54704/A
NARROW or 3 kc/s	50 microvolts	250 microvolts
WIDE, or 8 kc/s	100 microvolts	500 microvolts

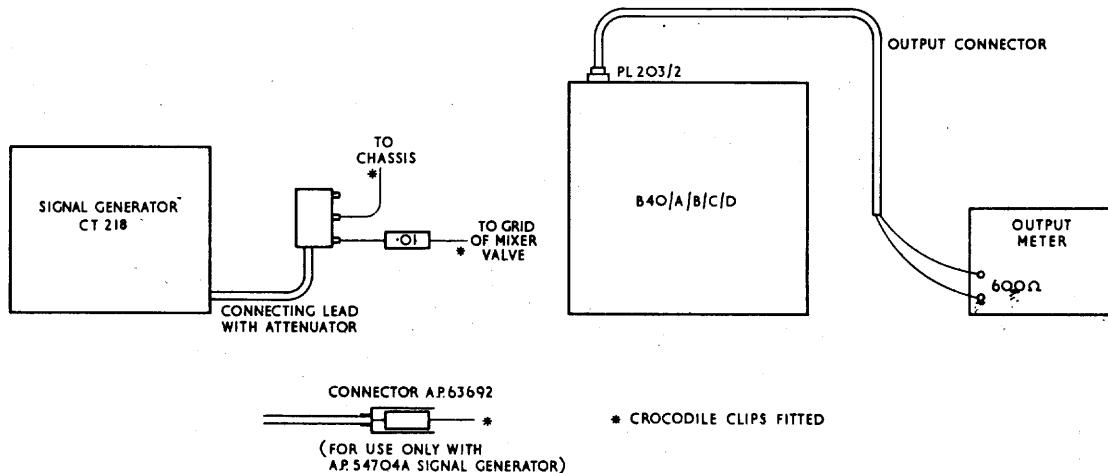

FIG. 16
TEST EQUIPMENT CONNECTION DIAGRAM

The Drill

85. STEP

PROCEDURE

- 1 Receiver controls as follows:-
 - (1) ANTI-CROSS-MOD. control fully clockwise
 - (2) CRYSTAL switch - ON, with crystal removed
 - (3) SYSTEM switch - CAL.
 - (4) LIMITER switch - OFF
 - (5) OUTPUT switch (at back of receiver) - toggle toward rear of receiver
 - (6) LOUDSPEAKER switch - ON
 - (7) GAIN control - fully clockwise
 - (8) AF GAIN control - fully clockwise

RECEIVER	BANDWIDTH SWITCH	A. G. C. SWITCH
B40/A	Narrow	-
B40B/C/D	3 kc/s	OFF

STEPPROCEDURE

2 Signal Generator controls as follows:-

Operate on C.W.

Tune to 500 kc/s, and tune exactly for zero reading in the output meter. (Zero beat with receiver calibrator.)

3 Receiver controls

Monitor L.S. switch - OFF

SYSTEM switch - R/T

4 Signal Generator controls

Modulate carrier at 1000 or 400 cycles, per second, 30%

Output - adjust output level for a reading of 500 milliwatts in the output meter. Check that signal generator output voltage does not exceed the figures quoted in the table below.

5 RECEIVER BANDWIDTH SWITCH to:-

8 kc/s - B40B/C/D

or

WIDE - B40/A

Adjust the signal generator output for a reading of 500 milliwatts in the output meter.

Check that the signal generator output voltage does not exceed the figures given in the table below:-

BANDWIDTH SWITCH	CT218	A.P. 54704/A
3 kc/s	50 microvolts	250 microvolts
8 kc/s	100 microvolts	500 microvolts

IF STAGE GAIN

PART 2

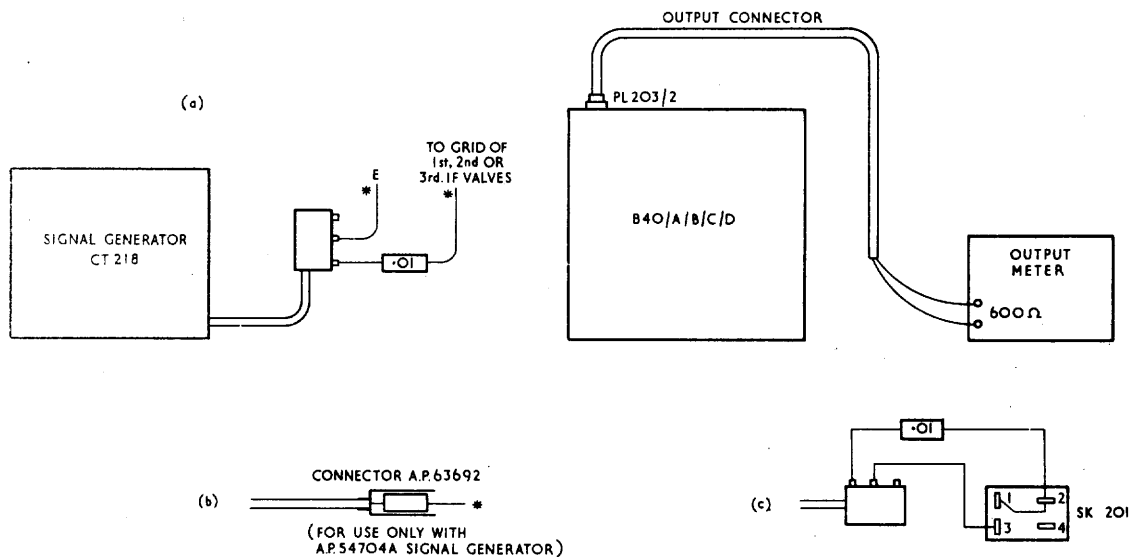

* CROCODILE CLIPS FITTED.

FIG. 17
TEST EQUIPMENT CONNECTION DIAGRAM

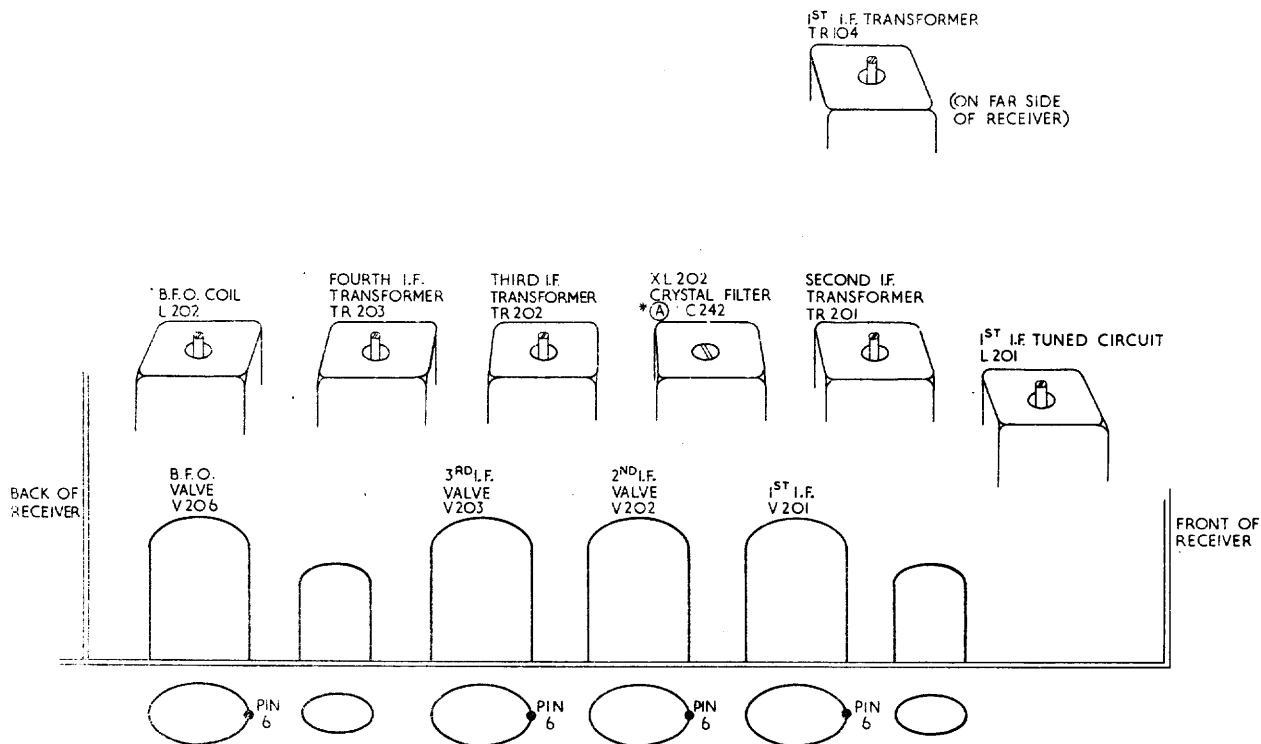

NOTE:- 1. PIN 6 MAY BE IDENTIFIED BY THE GREEN COVERED WIRE CONNECTED TO IT.
2. IN THE CASE OF B40D, THE GRID PIN IS PIN 1. (SEE FIG.2 CHAPTER 6)

* IN B40/A, THE ITEM MARKED (A) IS NOT FITTED. TR 201 IS FITTED IN THE POSITION SHOWN OCCUPIED BY (A), AND L 201 IN THE PLACE SHOWN OCCUPIED BY TR 201.

FIG. 18

Test requirement

86. A 500 kc/s signal, modulated 30% at 400 or 1000 cycles per second, is applied to the grids of the three IF valves in turn, to give a receiver output of 500 mW.

Test Point	Input level to all patterns of B40	
	CT218	A.P.54704/A
SK201 *	125 microvolts	600 microvolts
V201	600 "	2.5 millivolts
V202	11 millivolts	45 "
V203	100 millivolts (approx.)	800 "

For a receiver output of 500 milliwatts, the input should not exceed the figures given in the Table above.

* refer to Fig. 17(c) for details of CT218 connection to SK201.

The Drill87. STEPPROCEDURE

1

Receiver controls as follows:-

- (1) ANTI-CROSS-MOD. control - fully clockwise
- (2) CRYSTAL switch - ON. Remove crystal
- (3) SYSTEM switch - CAL.
- (4) LIMITER switch - OFF
- (5) OUTPUT switch at back of receiver, toggle towards back of receiver
- (6) LOUDSPEAKER switch - ON
- (7) GAIN control - fully clockwise
- (8) AF GAIN control - fully clockwise
- (9)

RECEIVER	BANDWIDTH SWITCH	A.G.C. SWITCH
B40/A	Narrow	-
B40B/C/D	3 kc/s	OFF

STEPPROCEDURE

- 2 Signal Generator controls as follows:-
 Switch to C.W.
 Tune to 500 kc/s, and tune for zero reading in the output meter.
 (Zero beat with receiver calibrator)
- 3 Receiver controls as follows:-
 MONITOR LOUDSPEAKER switch - OFF
 B4O/A - SYSTEM switch to MANUAL
 Clip a 0.01 μ F capacitor between the grid
 of the b.f.o. valve and chassis. (See Fig. 18)
 Short circuit R223.
 B4OB/C/D - SYSTEM switch to R/T
- 4 Signal Generator controls as follows:-
 Modulation - 400 c/s or 1000 c/s (as applicable)
 30% depth of modulation.
- 5 Connect the signal generator output via the 0.01 μ F
 capacitor - (N.B. This is "built-in" in Connector A.P.63692) -
 to the grid of the third IF valve, (V203). Check that an
 output of 500 milliwatts can be obtained with less than the signal
 input specified in the chart under "Test requirement".
- 6 Repeat the procedure in (5) with the signal generator output
 connected successively to the grid of the second and first IF
 valves.
- 7 Repeat the procedure in (5) with the signal generator output
 connected between pins 2 and 3 of SK201 with PL103 removed
 (see Fig. 17(c)).

RF GAINTest equipment required

88.

Description of instrument	Identity	A.P.
Signal Generator covering 1 Mc/s to 24 Mc/s	CT218 Marconi	10S/16780 54704/A
Output Meter and Connector (see para. 16)	Decibel Meter Portable No. 3 TF340	ZD.00022 54708
Connector - For use with CT218	-	64960
Connecting lead with attenuator	-	Supplied with CT218

The following additional items will be required if A.P.54704A Signal Generator is used:-

- Attenuator - A.P.63693
 Connector - A.P.63692 (non-aerial inputs)
 Connector - A.P.63691 (Aerial input)

The following special item is required:-

A 68 ohm $\frac{1}{2}$ watt resistor, in series with a 0.01 μF capacitor, with crocodile clips at the free ends (Fig. 19(c))

Test requirement

89.(a) The following table gives:-

- (i) The equivalent voltage at the test point, (assuming no attenuators)
 (ii) The voltage shown on the CT218 output level indicator
 and (iii) The voltage shown on the A.P.54704/A output indicator

(b) For a receiver output of 500 milliwatts, the signal input modulated at 400 c/s (A.P.54704/A) or 1000 c/s (CT218), at 30%, should not exceed the figures laid down in the table.

Band	Freq. (Mc/s)	Signal Generator Output reading in microvolts (except "Equivalent" Col.)											
		Mixer Grid (Turret Contact 13)			2nd RF Valve Grid (Turret Contact 8)			1st RF Valve Grid (Turret Contact 3)			Aerial		
		Equi- valent	CT218	54704	Equi- valent	CT218	54704	Equi- valent	CT218	54704	Equi- valent	CT218	54704
1	1.05	100	100	500	90	90	450	7	700	3500	Not more than 1 microvolt on any range	Not more than 100 microvolts on any range	Not more than 1000 microvolts on any range
2	2.6	80	80	400	25	25	125	4	400	2000			
3	6.4	80	80	400	20	20	100	3	300	1500			
4	13.1	80	80	400	20	20	100	3	300	1500			
5	25	80	80	400	20	20	100	3	300	1500			

90. The variation between the figures given under "equivalent", "CT218" and "54704" may be explained as follows:-

Under "Mixer Grid" and "2nd RF Valve Grid"

- (a) The "equivalent" and "CT218" figures are the same, but because the 54704/A 10:1 attenuator is not correctly terminated i.e. it is connected across a high impedance, the actual attenuation is approximately 5:1 in practice.

Under the "1st RF Grid" and "Aerial"

(b) The "54704/A" figure for the 1st RF valve is 500 times the "equivalent" figure, due to the 100:1 attenuator in the IF stages, and the 5:1 step down of the incorrectly matched A.P.63693 attenuator. When connected to the aerial, the 54704/A figure is 1000 times the "equivalent" figure, since the attenuator is now correctly matched and gives its normal 10:1 step down in voltage. Due to the 100:1 IF attenuator, the "CT218" figure is 100 times greater than the "equivalent" figure for both the 1st RF grid and aerial measurements.

Details of the attenuators employed are given under the Test Equipment Connection Diagrams.

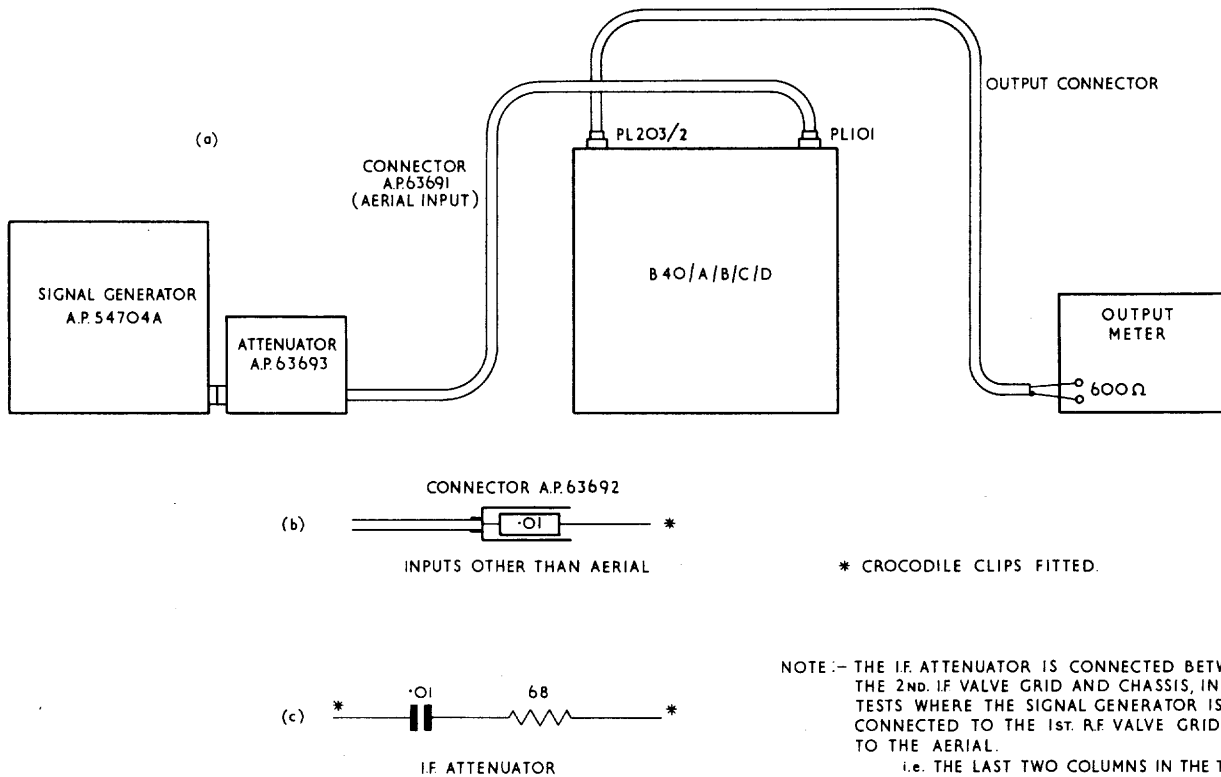
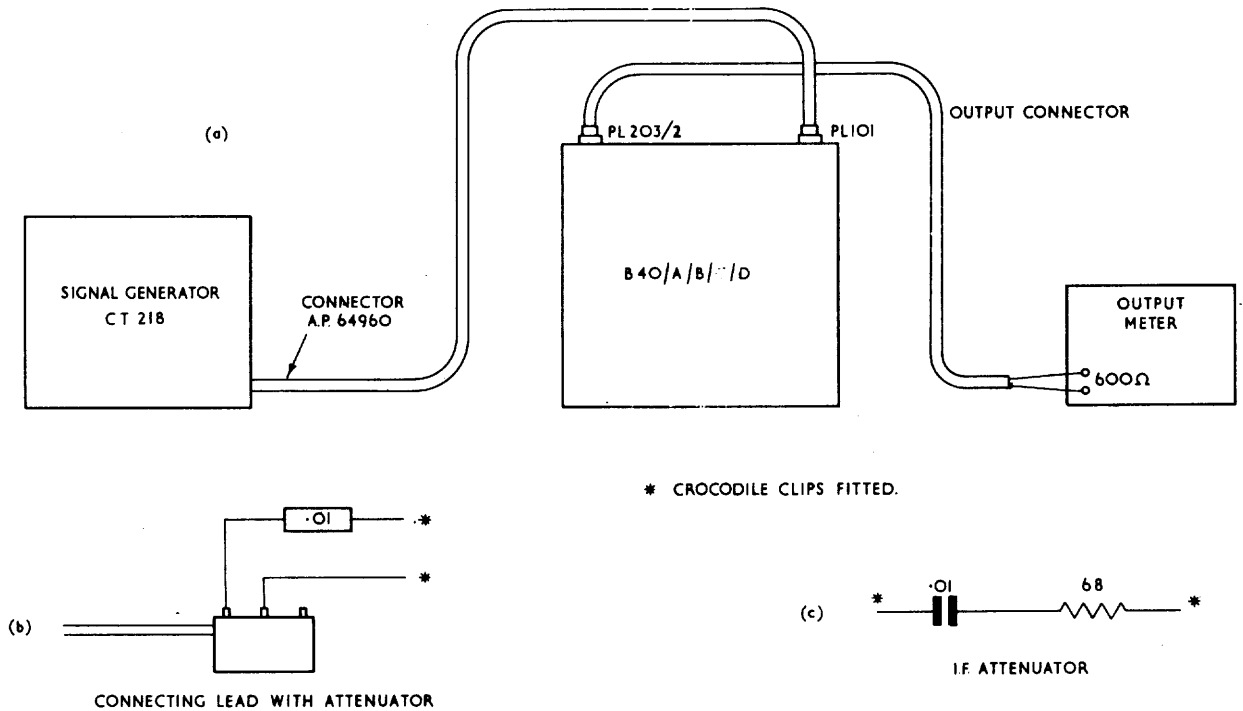

FIG. 19
TEST EQUIPMENT CONNECTION DIAGRAM



NOTE:- THE IF ATTENUATOR IS CONNECTED BETWEEN THE 2ND. IF VALVE GRID AND CHASSIS, IN TESTS WHERE THE SIGNAL GENERATOR IS CONNECTED TO THE 1ST. R.F. VALVE GRID, OR TO THE AERIAL CONNECTOR
i.e. THE LAST TWO COLUMNS IN THE TABLE.

FIG. 20
TEST EQUIPMENT CONNECTION DIAGRAM

The Drill

91. STEP

PROCEDURE

1

Receiver controls as follows:-

- (1) ANTI-CROSS-MOD. control - fully clockwise
- (2) CRYSTAL switch - OFF
- (3) OUTPUT switch at back of receiver - toggle towards back of receiver
- (4) LOUDSPEAKER switch - OFF
- (5) GAIN control - fully clockwise
- (6) AF GAIN control - fully clockwise

STEP

PROCEDURE

(7) TUNE to 1.05 Mc/s

(8)

RECEIVER	BANDWIDTH SWITCH	SYSTEM SWITCH	A.G.C. SWITCH
B4O/A	Narrow	Manual	-
B4OB/C/D	3 kc/s	R/T	OFF

NOTE:- B4O/A - stop b.f.o. valve oscillating by connecting a 0.01 μ F capacitor between its grid and chassis. Short circuit R223.

2 Signal Generator controls as follows:-

(1) Modulation - CT218, 1000 c/s
A.P.54704A, 400 c/s 30%

(2) Output - Connect to receiver mixer grid, using the appropriate connector.

(3) Tune to 1.05 Mc/s, and adjust tuning for maximum output meter reading.

3 Signal Generator output level to give an output meter reading of 500 milliwatts. Check that this output level does not exceed the figure specified in the table for the signal generator in use.

4 Repeat the procedure, with the signal generator connected in turn to the second RF valve grid, the first RF valve grid, and lastly, to the aerial connector, employing the connectors and attenuators specified.

5 Repeat the whole procedure for the remaining four frequency bands.

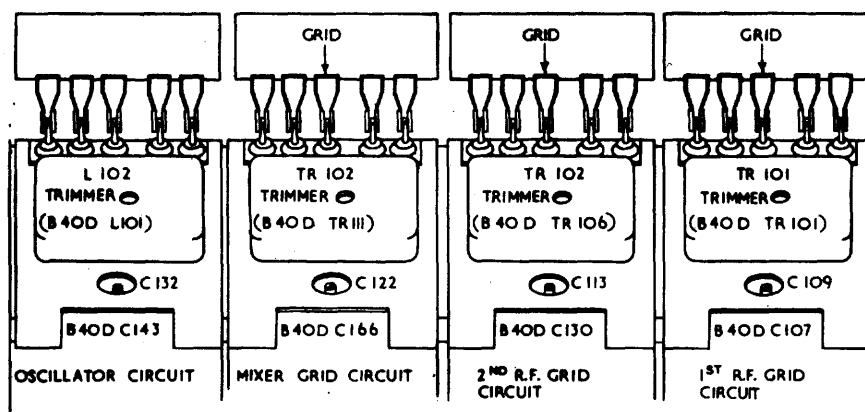

DETAILS OF R.F. COIL ASSEMBLY

FIG. 21

CHAPTER 8

REPAIR DATA FOR MARK 4 PLUGS AND SOCKETS

LIST OF CONTENTS

	<u>Para.</u>
Introduction	1-2
Routine Maintenance	3
Replacement, Connection and Mounting	4
Solder and Flux	5
Method of Soldering	6
Preparation of conductors	7
Preparation of Pole Contacts	8
Temporary Mountings	9
Making the connections	10
Cleaning	11
Mounting the Plugs (Fixed, Panel Mounting)	12
Assembly of the Sockets (Free Cable terminating connectors)	13
Socket Assembly details	14-15
Specific details of Mark 4 Connectors fitted to Receiver B40 ...	16
Fitting the 4 pin Mark 4 Socket to the Aerial Cable A.P.13831	17
Mark 4 Plugs and Sockets, Components List	18

LIST OF FIGURES

	<u>Fig.</u>
Mark 4 Plug and Socket, Pin identification	1
Assembly of Miniature Cable with Mark 4 Socket	2
Assembly details Mark 4 Sockets	3
Mark 4 Socket connections to Co-axial Cable	4
Mark 4 Connectors, Components comprising the free socket termination in the order in which they are placed on the cable	5

CHAPTER 8

REPAIR DATA FOR MARK 4 PLUGS AND SOCKETS

Introduction

1. The range consists of nine basic sealed multipole plugs and sockets accommodated in small, medium or large size shells. The Receiver B40 is fitted with three of these plugs and sockets, all of them being of the small shell size, as illustrated in Fig. 1.

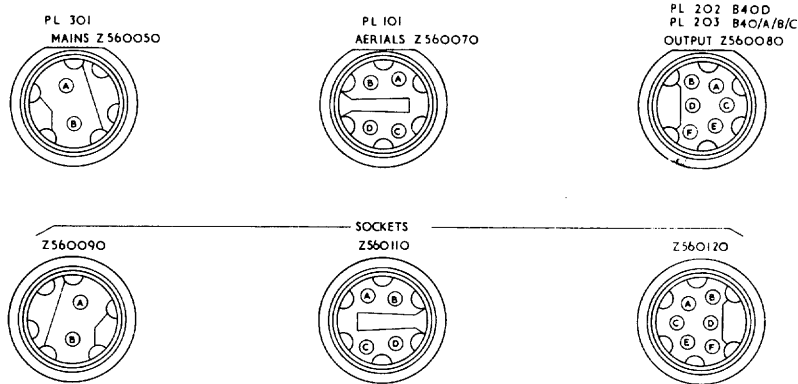

FIG.1 RECEIVER B40 AP 57140/A/B/C
MK 4 PLUGS & SOCKETS PIN IDENTIFICATIONS

2. These components are normally employed as fixed plugs for panel mounting and free sockets for terminating connectors. They are designed for use with Vinmetsmall and Metvinsmall cables.

Routine Maintenance

3. (a) Mating

When mating fixed and free items, care should be taken to ensure that the free item is fully engaged. The coupling nut should be tightened as far as possible by hand; spanners should not be used.

(b) Lubrication of Screw Threads

Screw threads should be lightly coated with Grease Anti-Seizing A.P.556.

(c) Testing

The use of prods with sharp points for testing or other purpose should be avoided. The test connections should be made to simulate the normal engagements of the mating contact.

Replacement, Connection and Mounting

4. General

The miniature cables used with these plugs and sockets are insulated with polythene; care must be taken, therefore, to avoid damaging this with the heat of the soldering operation. The compact design also necessitates especial care in soldering. However, if due attention is paid to the methods laid down in the following procedure, little difficulty will be experienced.

Solder and Flux

5. A good quality solder with resin core should be used.

Method of Soldering

6. (a) One pole of a suitable transformer (Approx: 1 Volt, 80 Amps) or battery of similar rating, is connected by means of a mating item, or contact to the contact to be soldered. The other pole is connected through a flexible lead to a metal or carbon pencil bit, approximately a quarter of an inch in diameter tapering to a chisel point; aluminium has been found to be a suitable material for this bit. In soldering, the bit is applied firmly to the surface of the part to be soldered, which is thus heated by the current which flows.
- (b) An electric, or high pressure gas soldering iron with a similar pencil bit, tinned on one face only may be used but will be found to be less convenient. The heat from the gas iron should be correctly adjusted by experiment.

Preparation of Conductors

7. (a) The ends of the cable should be in accordance with the cable connection details given in para. 14. If the insulation or any part of the conductors have become damaged, when removing a faulty plug or socket, it will be necessary to replace the conductor or cable concerned. The cable should be drawn a sufficient distance through the appropriate outlet fittings to enable the soldering operation to be performed.
- (b) See that the insulation of the conductors is stripped for approximately $\frac{1}{8}$ in. and the bare ends tinned with the minimum of heat, preferably by dipping them into a bath of molten solder. It is important to see that the exposed ends are trimmed accurately and the exposed part of the conductor kept to a minimum. Synthetic rubber sleeves should be fitted at this stage, in such a manner that they can be rolled down over the soldered connections.

Preparation of Pole Contacts

8. All "buckets" of pole contacts should be carefully tinned, using the minimum of heat. Excess solder must be avoided and any excess flux removed.

Temporary Mountings

9. It will be found that the soldering operation is facilitated if the item to be soldered is held by mating with the corresponding plug or socket, preferably mounted at an adjustable angle. The contacts of this mating item can be connected to one pole of the low voltage supply, if electrical soldering as described in para. 6(a) is employed.

Making the connections

10. (a) If it should be necessary to repair a connection, sufficient conductors should be unsoldered to allow easy access. After the repair is complete, they should be reconnected in the order outlined in the following paragraph, which is the procedure to be followed for the complete connection of a plug or socket.
- (b) Arrange the outlet fittings on the conductor [see paragraphs 12 (fixed items) or 14 (free items)]. Hold the conductor ready, melt the solder in the bucket at the left hand end of the bottom row of contacts, with the minimum of heat. The conductor is then dipped into the molten solder and the heat instantly removed. The solder should be used very sparingly, blobs and spikes should be avoided. The same procedure is then followed for the other contacts in the row, working from left to right. After each row is completed, the joints should be checked by giving each conductor a slight pull, and rubber sleeves, if used, rolled down over the joints until the ends are flush with the surface of the moulding. The other rows should be treated similarly working from the bottom to the top.

Cleaning

11. After the soldering operation the face of the moulding must be cleaned and any solder, flux or other matter, which may impair the electrical performance, removed. A stiff brush and a little carbon tetrachloride will be found useful for this operation.

Mounting the Plugs (Fixed panel mounting)

12. (a) First the plain metal mounting ring should be screwed up to the body until it just touches the rubber gasket, which should then lie in its hollow edge without distortion. The feather edge of the mounting may then be bent to the "D" flat of the body to prevent rotation. Before mounting the item, the sealing gasket, panel face and the adjacent threads of the shell should be given a thin coat of bakelite varnish, care being taken to prevent the varnish getting to those working threads, engaging with the coupling nut.
- (b) The plug is pushed through the panel and the locking ring screwed home finger tight. If the panel is $\frac{3}{32}$ in. thick or less, the mounting washer must be used under the locking ring. The plug should then be held with the appropriate male body holder and the locking ring tightened home with the semi-tubular spanner.

Assembly of the Sockets (Free Cable Terminating Connectors)

13. (a) As this assembly is more involved, than that for the panel mounting items, details are given step by step with the accompanying illustrations to make the drill as simple as possible. It must be realised that the whole operation should be tackled with extreme care and attention to detail, to produce a workmanlike job.

14. (1) Prepare the ends of the cable as shown by stripping the P.V.C. sheathing, braid and polythene tape. Strip and tin-dip the wire ends. Dimension "A" should be $\frac{1}{2}$ in. for the straight outlets and $\frac{7}{8}$ in. for the right angled outlet.

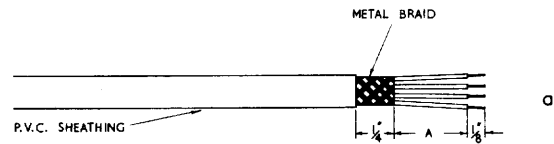

- (2) Thread the outlet fittings on the cable as shown, comb out the metal braid and solder the conductors to the bucket ends. A Helsyn sleeve, for $\frac{1}{4}$ in. cable, should be used for packing if necessary.

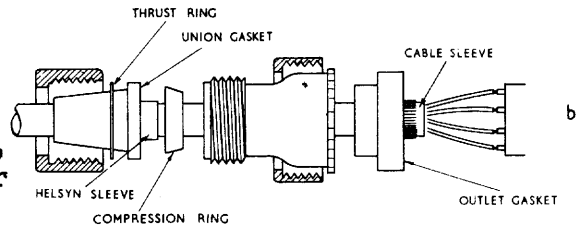

- (3) With the outlet gasket inside, lock the outlet to the moulding assembly with the outlet nut. Move the compression ring on the braid, just clear of the P.V.C. sheathing. Pull the ends of the braid out at right angles to the cable and trim. Adjust cable sleeve close to compression ring.

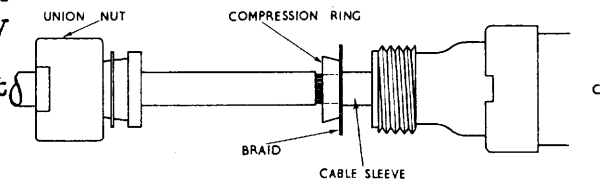

- (4) Bend the braid back over the compression ring, taking care that the ends do not project over its rear face. Slide the union gasket up to the rear face of the compression ring, over the Helsyn sleeve.

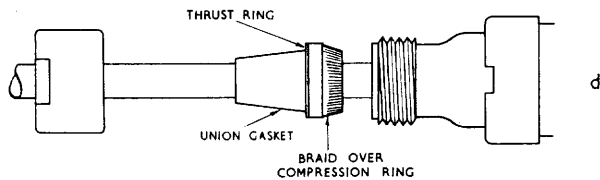

- (5) Force the cable into the outlet member until the braid seats into it, (the conductors will bow to permit this). Bring up the thrust ring and lock with the union nut.

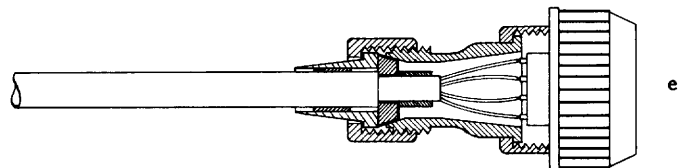

ASSEMBLY OF CABLE WITH MK.4 SOCKET

FIG. 2

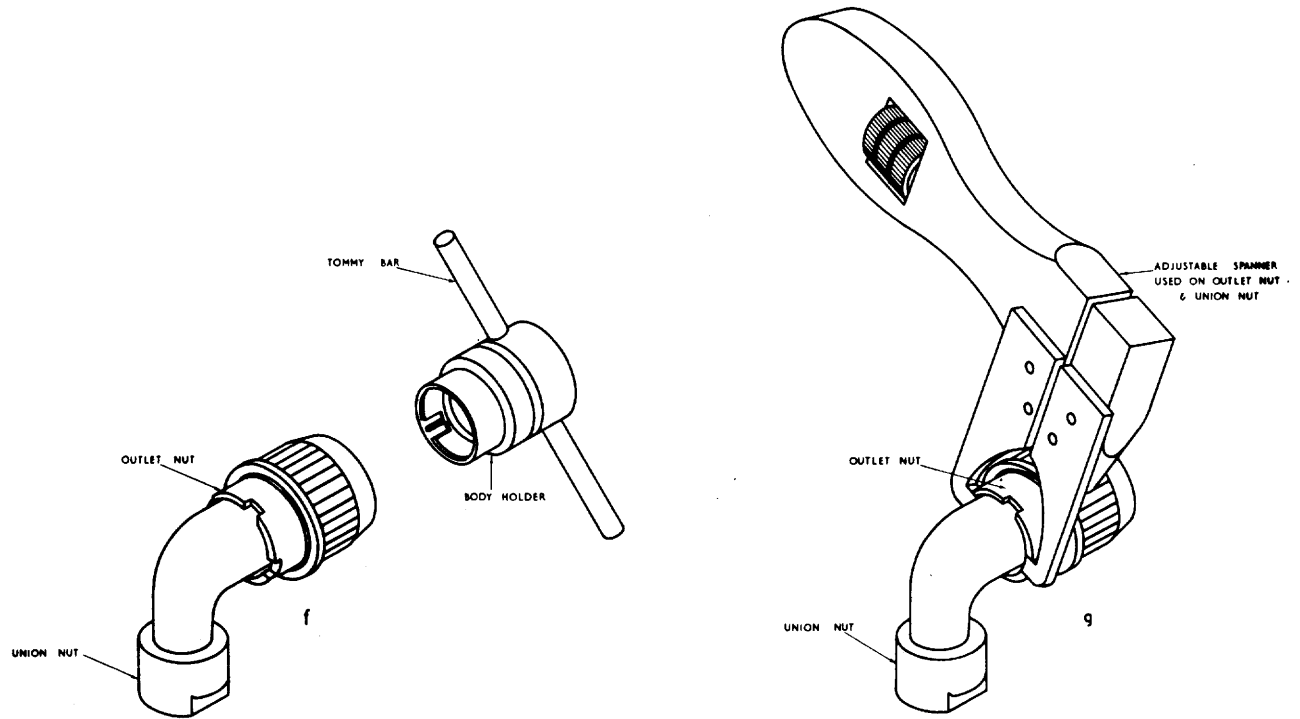

ASSEMBLY DETAILS OF MK. 4 SOCKET

FIG. 3

15. Special tools are supplied with these connectors. One of these, the female body holder, should be used to hold the cable unit, while the outlet nut is tightened with the special spanner. When both halves of the connection are mated the cable nut should be fully engaged and the coupling nut tightened by hand. A small amount of lubricant (A.P.566) should be applied to all screw threads.

Specific Details of Mark 4 Connectors fitted to Receiver B40

16. (a) Plug PL101, Aerial Connector

In most installations, the cable for the free item consists of a single co-axial line (A.P.13831) connected to Pin C. The only other connection being a link between Pin A and Pin B. The cable braid screen is securely bonded to the body of the socket.

- (b) Plug PL203 or PL202, Output Connector

Although this is a six pin connector, as a rule only four connections are necessary, therefore the specified miniature cable is JS6145-100015.

(c) Plug PL301, Mains Connector

The miniature cable required for this connector is JS6145-1000008.

Note. Further details can be obtained from Installation Specifications B.705 and B.649/R1.

Fitting the 4 pin Mark 4 Socket to the Aerial Cable (A.P.13831)

17. The co-axial aerial input cable should be connected to the Mark 4 socket as follows:-

(1) Prepare the cable A.P.13831 as shown in (a).

(2) Thread the union nut and thrust ring on to the cable as shown. Place the gasket union on to the cable in such a position that it coincides with the end of the P.V.C. sheath on the cable. To prevent damage to the cable during this operation Hellerman type pliers should be employed if available. Afterwards thread on the compression ring and trim the braiding as shown in the diagram (b).

(3) Comb out the braiding left after trimming as in (2) above, this will consist of all the braid projecting beyond the compression ring. Bend back the braiding in a similar manner to that shown in Fig. 2(d) so that it is taken over the compression ring, taking care that the ends do not project over its rear face. Thread on the outlet straight and secure it tightly against the braid and compression ring with the union nut. Ease the assembly back as far as it will go over the polythene, trim the cable to expose the conductor as shown. Thread on the outlet gasket and solder the conductor to Pin C on the socket. Pins A and B are soldered together with a small piece of wire (c).

(4) Ease the assembly over the polythene until it mates with the socket. Secure with the outlet nut (d).

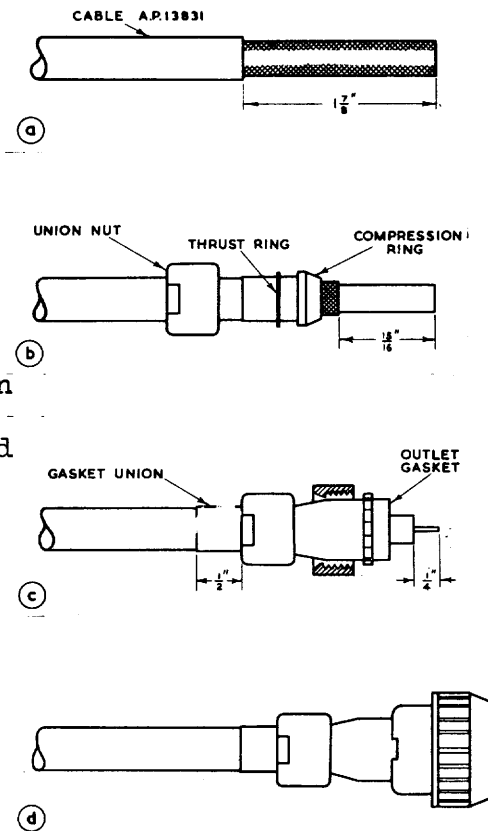

MK4 SOCKET CONNECTIONS TO COAXIAL CABLE
FIG. 4

FIG. 5

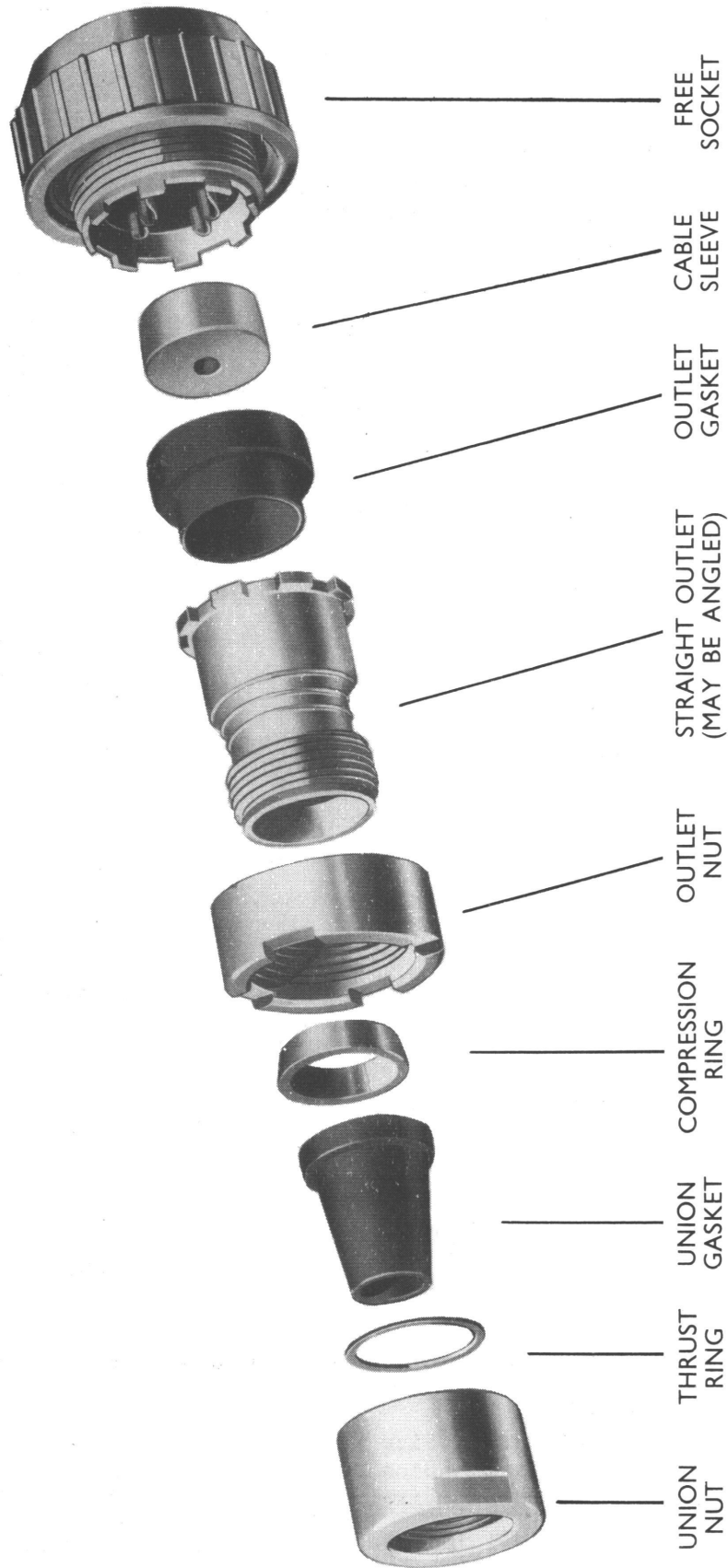

MARK 4 CONNECTORS

COMPONENTS, COMPRISING THE FREE SOCKET TERMINATION
IN THE ORDER IN WHICH THEY ARE PLACED ON THE CABLE

MARK 4 PLUGS AND SOCKETS

COMPONENTS LIST

Joint-Service
Catalogue
No.

18.

Mounted on the Receiver

Plug, fixed, 2 pin (Mains Input)	Z560050
Plug, fixed, 4 pin (Aerial Input)	Z560070
Plug, fixed, 6 pin (Audio Frequency Output)	Z560080

The mating sockets (cable entry) for these plugs are catalogued in their component parts and are supplied with the receivers as follows:-

For mating with 2 Pin Plug Z560050

Socket, free, 2 way	Z560090
Gasket, union	Z970107
Gasket, outlet	Z970058
Outlet, angle including:-	Z970068)
Nut, union	Z970127)
Ring, thrust	Z970095
Ring, compression	Z970101
Cable Sleeve	Z970101

Alternative improved items for use with mains input cable 6145-910-0008 are as follows:-

Socket, electrical (free) male shell	5935-99-056-0090
Seal, rubber, special shaped section	5935-99-011-9877
Shield, electrical, plug-socket (angle)	5935-99-011-9122
Adaptor, cable to electrical plug-socket	5935-99-097-0293
Washer flat	5310-99-097-0095
Ring, electrical bonding	5975-99-097-0101
Seal, rubber, special shaped section	5935-99-097-0107
Sleeve, cable binding	5975-99-097-0114

For mating with 4 Pin Plug Z560070

Socket, free, 4 way	Z560110
Gasket, outlet	Z970058
Gasket, union	Z970108
Outlet, straight, including:-	Z970062)
Nut, union	Z970128)
Ring, thrust	Z970096
Ring, compression	Z970102
Cable Sleeve	

For mating with 6 Pin Plug Z560080

Socket, free, 6 way	Z560120
Gasket, outlet	Z970058
Gasket, union	Z970108
Outlet, straight, including:-	Z970062)
Nut, union	Z970128)
Ring, thrust	Z970096
Ring, compression	Z970102
Cable Sleeve	

It is not possible to draw from stores a complete assembly under a single number.

Spanner Kit, Pattern No. 056-9022

Body Holder, double-ended, male and female, Size 1	0273/056-9019
Body Holder, double-ended, male and female, Size 2	0273/056-9020
Body Holder, double-ended, male and female, Size 3	0273/056-9021
Spanner, Adjustable	0277/097-0134
Spanner, Semi-tubular, Size 1	0277/097-0133
Spanner, Semi-tubular, Size 2	0277/097-0137
Spanner, Semi-tubular, Size 3	0277/097-0140
Tommy Bar	0276/097-0143

CHAPTER 9REPAIR DATATUNING DRIVE MECHANISMLIST OF CONTENTS

	<u>Para.</u>
Description Receivers B40/A	1-6
Summary Receivers B40/A	7
Description Receivers B40B/C/D	8-9
Summary Receivers B40B/C/D	10
Checking the mechanism	11
Connecting the ganged capacitor to the drive	12
To remove the scale drum assembly	13
To remove the shaft and drum from the cursor frame	14
To re-assemble shaft and drum into the cursor frame	15
To re-assemble the scale drum assembly into the die casting ...	16
To adjust the cam operated stop bar	17
To adjust the locking mechanism and/or the clutch... ..	18
Removal of the upper gear box (I) on Receivers B40B/C/D	19

FIGURES

	<u>Fig.</u>
Receiver B40 A.P.57140/A Tuning drive mechanism	1
Receiver B40 A.P.57140B/C/D Tuning drive mechanism	2

CHAPTER 9

REPAIR DATA

TUNING DRIVE MECHANISM

DESCRIPTION RECEIVERS B40/A

1. From the drawing (Fig. 1) it will be seen that the tuning knob spindle assembly comprises the following items:-

The knob
The spindle (B)
The flywheel and clutch mechanism (C and D)
The logging scale (A) mounted on the flywheel
The worm gearing to the scale drum and gang (H and J)
The drive locking device (F, G and U)

2. The boss of the flywheel houses the clutch, which is a simple friction type comprising the spring (C) secured at the end of the spindle by the nut (D). Reference to the drawing will show that the spring fits over and along the spindle. It exerts sufficient pressure against the face of the flywheel for the turning moment provided by the knob and flywheel, to be transferred to the spindle and work the mechanism. When the drive is stopped by means of the locking device or cam operated stop, the clutch slips, so that only the knob and flywheel turn.

3. As flywheel tuning is employed, the resultant mechanical inertia could cause damage to the gang by exerting sudden excessive pressure at the ends of its travel, especially as it has a comparatively fragile ceramic spindle. To prevent this, the cam operated stop is fitted. It is located at the bottom of the worm wheel shaft and is in two parts:- A driver plate (T) securely fixed to the shaft and a cam plate (S) mounted on top of the driver plate but free to revolve on the shaft. Due to the gearing, the total movement of this shaft is about one and a half turns, from the closed to the open position of the gang. A slot is cut in the upper cam plate for a radial distance of approximately 180°; a lip from the lower fixed plate engages into this slot, resulting in the lower plate travelling for about half a turn as the lip moves along the slot, before it reaches the end and starts to drive the upper cam plate. Thus for one and a half turns of the under fixed plate (T) the upper plate (S) will only revolve once, to operate the spring loaded push rod (E) against the stop (R) on the logging scale, at each end of the gang traverse.

4. The mechanism can also be stopped at any given point by means of the dial locking device. The dial lock lever (F) when placed in the locking position, turns an eccentrically grooved shaft (G) at right angles to the tuning spindle to produce sufficient breaking effect on this spindle (in the item (U)) to stop it turning. The lever has a spring loaded clutch to prevent the grooved shaft from jamming the tuning spindle.

5. The worm (H) at the end of the tuning spindle drives the worm wheel (J). The scale drum (K) which rotates on the spindle (M) is driven by the split driving pinion (L). This spindle is helically grooved and imparts a vertical up or down motion as it rotates. The pitch of this helical groove on the spindle is the same as the helically graduated scale on the drum: this results in each individual scale being presented through 1.82 turns of the drum, due to the ratio between the pinion (L) and its mating gear on (M).
6. A chain sprocket (H) is mounted underneath the split driving pinion on the wormwheel shaft. This is connected by a suitable chain to a further sprocket (P) mounted on the ganged capacitors spindle. The chain incorporates a spring (Q) with a torsion bar (V) to reduce backlash. (Pattern 57140 is fitted with the spring only.) Due to the relative size of the chain sprockets a transmission reduction of 3:1 takes place through this particular drive, as the reduction from the tuning spindle to sprocket (P) is 20:1, it follows that the total reduction to the gang is 60:1.

SUMMARY RECEIVERS B40/A

7. (a) The gear box reduction ratio is 20:1.
- (b) The chain drive reduction is 3:1.
- (c) Total speed reduction from the tuning knob to the ganged variable capacitors is 60:1.
- (d) During the whole travel of the tuning mechanism between the mechanical stops the variable capacitors are rotated through about $173\frac{3}{4}^{\circ}$ and not 180° .
- (e) The scale drum calibrations are marked on a helix and the drum turns through about 1.82 turns to move past the cursor. As it rotates the drum rises or falls $\frac{1}{2}$ in. each complete turn.
- (f) Backlash throughout the mechanism is taken up by spring loading.
- (g) The stop bar engages with an angle piece on the high speed shaft of the gear box and is cam operated from the gear box low speed shaft.
- (h) The tuning knob drives the gear box through a friction clutch that prevents an excessive strain being placed on the mechanism when the stops are hit.
- (j) The tuning mechanism flywheel makes easier, large movements of the ganged capacitors.

DESCRIPTION RECEIVERS B40B/C/D Fig. 2

8. The clutch, flywheel, locking and stopping devices are the same as those in Receivers B40/A previously described. The drawing shows that the mechanism driving the scale drum, is exactly the same as for the other patterns.
9. The chain sprocket (N) is mounted at the end of the tuning spindle (B) instead of on the shaft associated with the driving pinion (L), thus it is not subjected to the 20:1 speed reduction of the earlier models and as the chain drive ratio between sprockets (N) and (P) remains the same, the reduction is provided by a further gear box (X) in the transmission from the sprocket (P) to the ganged capacitors. Jockey pulleys (Y) are fitted in the chain drive to take up any slack. The arrangement constitutes a considerable improvement over the earlier patterns, resulting in reduced backlash.

FIG. 1

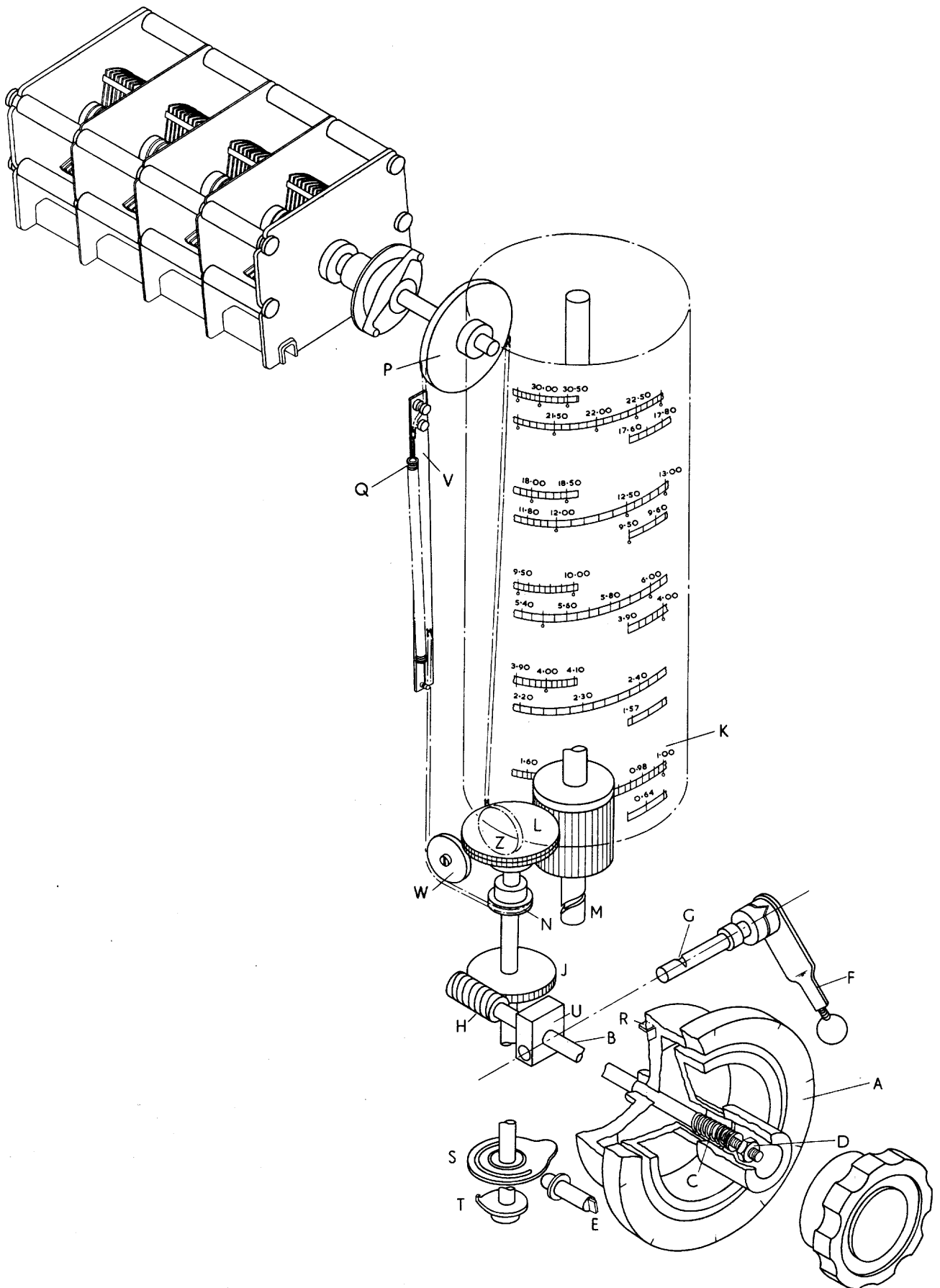

RECEIVER B40 A.P. 57140/A
TUNING DRIVE MECHANISM

FIG. 2

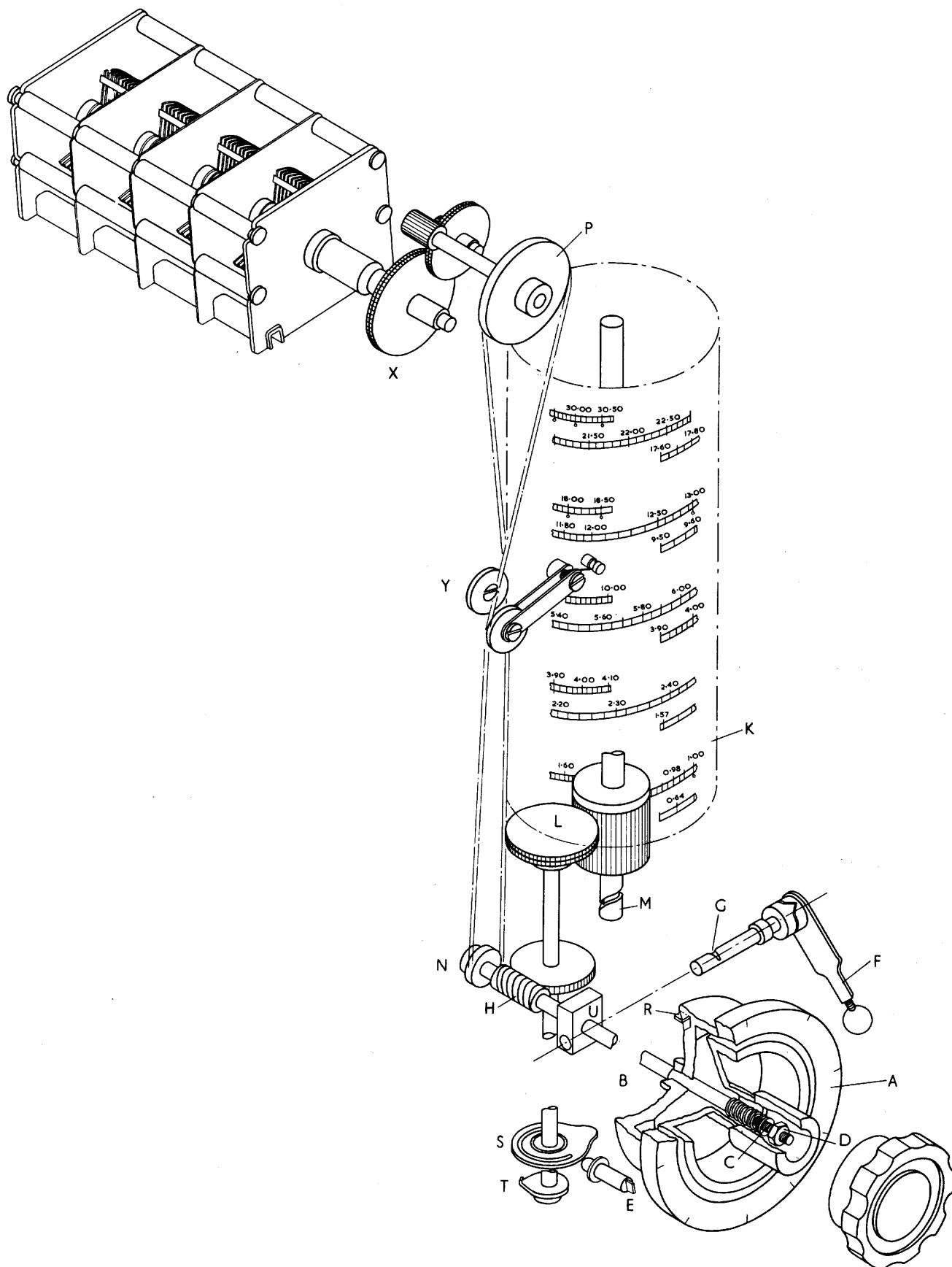

RECEIVER B40. A.P. 57140 B/C/D
TUNING DRIVE MECHANISM.

SUMMARY RECEIVERS B4OB/C/D

10. (a) Reduction to driving pinion (L) is 20:1.
- (b) Ratio between pinion (L) and the scale drum, about 1.5 turns to 1.82 turns.
- (c) Reduction from the tuning spindle through the chain drive is 3:1.
- (d) Reduction between the chain drive and the ganged capacitors is 20:1.
- (e) Total reduction from the spindle to the ganged capacitors is 60:1.
- (f) The backlash is not more than \pm one division of the logging scale.
- (g) The stop bar engages with an angle piece on the high speed shaft of the lower gear box and is cam operated from the associated low speed shaft.
- (h) The tuning knob drives the gear box through a friction clutch, which slips to prevent an excessive strain being put on the mechanism when the stops are hit.
- (j) The flywheel facilitates large movements of the ganged capacitors.

CHECKING THE MECHANISM

11. Warning. Before making any adjustments, free the shaft of the ganged capacitors from the drive by loosening the relevant grub screw. Failure to take this precaution can result in damage to the gang by causing it to turn through an angle greater than it would move with correctly adjusted stops.

(a) Scale Drum

The scale drum should be free on its shaft during the whole of its travel. If necessary it should be oiled.

(b) Scale Position

If the drum is too high or too low relative to the cursor pointers, it may be lowered or raised by slackening the $\frac{1}{4}$ in. B.S.F. lock nut at the top of the shaft and rotating this shaft with a screwdriver placed in the slot in the top.

Turn the tuning knob fully anti-clockwise and set the cursor pointers to the end of their corresponding scales. The pointer should be nearly central.

(c) Stops

With the cursor frame set as above, turn the tuning knob fully clockwise until engaged by the stop. The end of the scales should be within about $\frac{1}{16}$ in. of the cursor pointers. If the tuning drum overshoots by about $\frac{3}{4}$ in., the cam operated stop must be adjusted (see para. 17).

(d) Drive

All set screws securing the gears to their shafts must be tight on their flats. Similarly the screws on the stop bar operating cam should be tight.

(e) Chain

See that the chain is arranged as illustrated in Figs. 1 and 2 for the different pattern receivers. Make sure that it is not twisted and in B40/A receivers see that the tensioning coil spring (Q) does not foul either the upper capstan pulley (P) or the idler pulleys (W and Z) at the other end of the travel, thus restricting the tuning traverse. The chain should be lubricated with a thin layer of anti-seize grease A.P.556.

(f) Gang Capacitor Coupling

The coupling grub screw fixing the ganged capacitors shaft to the mechanism, must be accessible when the tuning knob is rotated fully counter-clockwise.

CONNECTING THE GANGED CAPACITOR TO THE DRIVE

- 12.
- (1) Turn the tuning knob fully counter-clockwise.
 - (2) Turn the gang shaft carefully by hand, until it is fully clockwise as seen from the front of the receiver.
 - (3) Holding the shaft in position by hand, tighten the grub screws. In Receivers B40B/C, Allen type grub screws are fitted and it will be necessary to have the special tool for fitting this item.

Note. It is essential that this operation is done at the LF end of the travel, for the angle through which it is rotated by the driving mechanism is much less than the angle through which the capacitor is free to rotate away from its fully anti-clockwise position.

TO REMOVE THE SCALE DRUM ASSEMBLY

- 13.
- (1) Unscrew and remove the logging scale pilot lamp holder.
 - (2) Remove the scale lamp carrier inside the drum after undoing the two retaining screwed rods at the top.
 - (3) Remove the $\frac{1}{4}$ in. B.S.F. hexagonal nut and washer at the top of the centre shaft.
 - (4) Pull forward the top of this shaft until it clears the die-casting, then lift out the assembly.

TO REMOVE SHAFT AND DRUM FROM THE CURSOR FRAME

- 14.
- (1) Lay the cursor frame, with the scale drum in it, face downwards on the bench.

- (2) Screw the shaft down the drum as far as it will go. Then remove the friction washer and the two $\frac{3}{8}$ in. B.S.F. hexagonal nuts from the shaft.
- (3) Screw the shaft right out of the assembly, from the top, taking care not to scratch the drum.
- (4) Lift out the drum.
- (5) Pull through the drum bearing with a piece of soft rag soaked in petrol or paraffin.
- (6) Clean the shaft with the same sort of rag.
- (7) Put a few drops of thin anti-seize lubricating oil on the shaft.

TO RE-ASSEMBLE SHAFT AND DRUM INTO THE CURSOR FRAME

15. (1) Lay the drum in the cursor frame so that the drum pinion boss is at the opposite end to the cursor knurled thumb plate.
- (2) Insert the shaft into the centre tube of the drum, through the top hole in the cursor frame, putting the helically cut end of the shaft in first. Screw the shaft until it projects as much as possible through the bottom hole of the frame.
- (3) On to the shaft put the two $\frac{3}{8}$ in. B.S.F. hexagonal nuts, with chamfered ends outwards, and then the friction washer. Have the nuts so that there is about $\frac{3}{8}$ in. of thread clear above the washer.
- (4) Screw back the shaft until the top end is inside, and flush with the upper end of the top hole in the cursor frame.
- (5) Check that the shaft is located vertically, and is free to turn.

TO RE-ASSEMBLE THE SCALE DRUM ASSEMBLY INTO THE DIE CASTING

16. (1) Lock the tuning, with the knob turned fully clockwise.
- (2) Hold the scale drum assembly vertical and have the spigot on the end of the shaft just projecting below the hole at the bottom of the cursor frame.
- (3) Allow the drum to roll down the helix to its lowest position.
- (4) Rotate the centre shaft until the cursor pointers are opposite the HF ends of the calibrated scales.
- (5) Insert the spigot on the end of the shaft into the hole in the bottom of the die casting.
- (6) Place one of the two $\frac{1}{4}$ in. steel washers on the top of the shaft just above the top bearing of the cursor frame.
- (7) Slide the top of the shaft backwards until this end just engages the slot in the die casting.
- (8) With the second finger of the right hand hold the top half of the split pinion (L) against its anti-backlash springs.

- (9) With the first finger of the right hand keep the drum turned so that the HF ends of the calibrated scales are central.
- (10) With the left hand, gently push the top of the shaft to the back of the slot in the top of the die casting.
- (11) On the top end of the shaft put the other $\frac{1}{4}$ in. steel washer, then the $\frac{1}{4}$ inch B.S.F. hexagonal nut.
- (12) Make sure that the anti-backlash springs in the pinion gearing are working and that the HF ends of the scales are central.
- (13) Raise the drum to the correct height by turning the centre shaft with a screwdriver fitted into the slot at the top end, until the cursor pointers just overlap the bottom of the two lines containing the calibration divisions of each scale.
- (14) Still holding the shaft steady with the screwdriver, tighten the $\frac{1}{4}$ in. B.S.F. hexagonal nut on the top.
- (15) Adjust the tightness of the friction washer holding the cursor frame, by altering the position of the two $\frac{3}{8}$ in. B.S.F. hexagonal nuts that are just below the cursor frame, until this can be comfortably, but not too easily, rotated by one thumb.
- (16) Replace the scale illuminating lamps. Make sure that the bottom end of the carrier for the lamps does not touch the inside of the drum at either side.

TO ADJUST THE CAM OPERATED STOP BAR

17. (a) This mechanism is indicated in the two drawings Figs. 1 and 2 by the letters "S" and "T". It is situated at the bottom of the low speed shaft of the reduction gear box to the scale drum. It is accessible, if the receiver is turned on to its right hand side. The following points must be checked:-
 - (i) The tuning knob should rotate about 28.95 turns between the operations of the cam against the stop bar. It is possible to rotate through either 27.95, 28.95 or 29.95 turns, according to the angular position of the operating cam on the shaft.
 - (ii) Adjust this angular position of the cam until the movement of the stop bar is the same at each end of the 28.95 turns of the tuning knob.
 - (iii) Make sure that the flat spring between the cam boss and the thrust race underneath the gear box occupies $\frac{1}{16}$ in. \pm $\frac{1}{64}$ in.; this should be measured when the gear box output shaft is held down by a finger applied to the end of the shaft at the top of the split driving pinion (L).

TO ADJUST THE LOCKING MECHANISM AND/OR THE CLUTCH

18. (1) Remove the tuning knob and unscrew the self locking nut (D) on the front end of the tuning spindle (B). Remove the washer helical spring and flywheel.
- (2) Turn the logging scale fully counter-clockwise. Set the cursor frame so that the pointer corresponds accurately with the LF end of the drum scale for Band 5. Lock the dial.
- Note. Do not touch the cursor again until the following adjustments are completed.
- (3) Undo the screw in the logging scale boss, and remove the logging scale complete.
- (4) Release the dial lock. BE CAREFUL NOT TO TOUCH THE TUNING SPINDLE.
- (5) Undo the screw in the end of the locking cross shaft (G). Remove the washer, helical spring and locking lever.
- (6) Loosen the grub screws in both the collars on the cross shaft.
- (7) Turn the cross shaft by finger pressure as far as it will go in a clockwise direction, looking at its right hand end.
- (8) Slide the inside collar up to the die casting and tighten the grub screw.
- (9) Place a thin piece of paper between the external collar and the spherical bearing and hold the collar tight against this bearing, with the cam faces in a horizontal position. Tighten the collar grub screw really hard. Remove the piece of paper.
- (10) Put back the locking lever, helical spring, washer and screw.
- (11) Lock the tuning spindle with the locking lever.
- (12) Replace the logging scale dial in the fully counter-clockwise position i.e. against its stop (R), and in such a position on the shaft that it has running clearance.
- (13) Tighten the screw in the logging scale dial boss.
- Note. If, when tried, the logging scale has not enough clearance, turn it back to the fully counter-clockwise position, lock the tuning spindle and undo the screw in the central boss. With the logging scale still held against its stop, move it a little along its shaft and re-tighten the central boss screw.
- (14) Release the tuning spindle. See that the logging scale revolves freely in a clockwise direction. In the anti-clockwise position the logging scale should be against the stop bar when the LF end of the tuning scale for Band 5 corresponds with the cursor pointer.
- (15) Replace the flywheel, spring, washer and the 2 BA hexagonal nut.

- (16) Tighten the self-locking 2 BA hexagonal nut until there is sufficient friction to drive the gears easily, but insufficient to overcome the lock when applied gently.

REMOVAL OF THE UPPER GEAR BOX (X) ON RECEIVERS B4OB/C/D ONLY

- 19.
- (a) This gear box is situated between the drive and the upper chain sprocket (P) on these patterns and provides the 20:1 speed reduction to the gang, lost on these models earlier on in the transmission; due to the chain drive being taken from the tuning spindle, instead of the wormwheel shaft as in the earlier patterns.
 - (b) It will be noted that the gear box is encased, and from the diagram Fig. 2 will be seen to consist of two split pinion wheels with anti-backlash springs, driven by corresponding spur gears, to give the required transmission reduction.
 - (c) The construction is such, that normally no maintenance will be required. However if it ever becomes necessary to remove the gear box for repair, the following procedure will achieve this:-
 - (1) Remove the scale drum.
 - (2) Slacken the grub screws keying the drive to the gang capacitor shaft.
 - (3) Remove the four fixing screws that secure the gang capacitors to the chassis and slide the gang away from the gear box until it is free of the spindle.
 - (4) Remove the chain sprocket (P) from the gear drive.
 - (5) Remove 3 fixing screws from the gear box frame situated directly behind the scale drum position.
 - (6) Remove the socket SK101, by withdrawing the fixing screws. The gear box can now be removed. When replacing reference should also be made to paragraph 12.

PART 3

ILLUSTRATIONS, COMPONENT LISTS

AND COIL DATA

PART 3ILLUSTRATIONS, COMPONENTS LISTS ANDCOIL DATALIST OF CONTENTS

	<u>Fig.</u>
<u>B40/A/B/C - RF Unit</u>	
Turret Switch components, layout diagram	1
Turret Switch components, circuit diagram	2
Right hand layout	3
Circuit diagram (opposite Fig. 3)	4
Circuit diagram (opposite Fig. 6)	5
Top layout	6
Components List	
<u>B40D - RF Unit</u>	
Turret Switch components, layout diagram	7
Turret Switch components, circuit diagram	8
Circuit diagram	9
Layout diagram (Right hand)	10
Components List	
<u>B40/A - IF Unit</u>	
Layout and switch wiring diagram	11
Circuit diagram	12
Components List	
<u>B40B/C - IF Unit</u>	
Layout and switch wiring diagram	13
Circuit diagram	14
Components List	
<u>B40D - IF Unit</u>	
Layout and switch wiring diagram	15
Circuit diagram	16
Components List	

LIST OF CONTENTS (Continued)

	<u>Fig.</u>
<u>B40/A - AF and Power Unit</u>	
Top layout	17
Bottom layout	18
Circuit diagram	19
Components List	
<u>B40B/C - AF and Power Unit</u>	
Top layout	20
Bottom layout	21
Circuit diagram	22
Components List	
<u>B40D - AF and Power Unit</u>	
Bottom layout	23
Circuit diagram	24
Components List	
B40/A, circuit diagram	25
B40B/C, circuit diagram	26
B40D, circuit diagram	27

REPAIR AND WINDING
DATA FOR COILS

TURRET COILS

	<u>Fig.</u>
RF coil from the base showing tag positions	28
<u>Aerial Coils (TR101)</u>	
Band 1	29
Band 1 B40C/D only	30
Band 2	31
Band 2 B40C/D only	32
Band 3	33
Band 3 B40C/D only	34
Band 4	35
Band 5	36
<u>First RF Coils (TR102)</u>	
Band 1	37
Band 2	38
Band 3	39
Band 4	40
Band 5	41
<u>Second RF Coils (TR103)</u>	
Band 1	42
Band 2	43
Band 3	44
Band 4	45
Band 5	46

LIST OF CONTENTS (Continued)Turret Coils (Continued)Oscillator Coil (L102)

	<u>Fig.</u>
Band 1	47
Band 2	48
Band 3	49
Band 4	50
Band 5	51

IF COILS

IF Coil Assembly for the base	52
IF Transformer (TR104) (B40D, TR116)	53
IF Coil (L201)	54
IF Transformers, TR201 and TR202 (B40/A)	55
IF Transformers, TR201 and TR202 (B40B/C/D)	56
IF Transformer, TR203	57
B.F.O. Coils, L202 and L205	58
Pitch Coils, L203 and L204	59
Choke RF, 1.5 mH	60
Crystal Filter Assembly, details (B40B/C/D)	61
Crystal Filter Wiring Diagram	62
Crystal Filter Coil L206 (B40B/C/D)	63
Note Filter L301, (B40/A)	64

IRON CORED TRANSFORMER AND CHOKE - DATA -

	<u>Para.</u>
Choke, A.P. 65560, L302	1
Choke, A.P. 65564, L303	2
Choke, A.P. 67762, L304	3
Output Transformer, A.P. 65689, TR301	4
Output Transformer Monitor Loudspeaker TR204 (B40D-TR303)	5
Mains Transformer A.P. 65561/A/B, TR302 (B40/A)	6
Mains Transformer A.P. 67763A, TR302 (B40B/C/D)	7

A.P. 67757 RECEIVER 62B

	<u>Fig.</u>
Circuit Diagram	65
Components List	

A.P. 67757A RECEIVER 62B

	<u>Fig.</u>
Circuit Diagram	66
Turret Switch Components	67
Components List	

FIG. 1

LOCAL OSCILLATOR

2ND R.F.

1ST R.F.

AERIAL

BAND 1

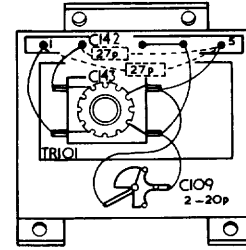
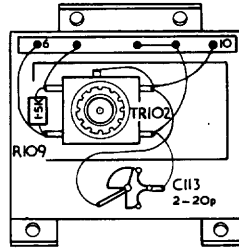
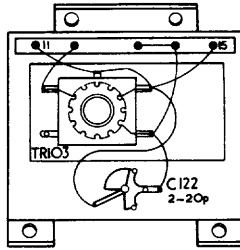
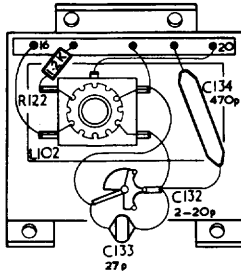

ADDITIONAL COMPONENTS
IN AP 57140 C. ARE SHOWN
DOTTED

BAND 2

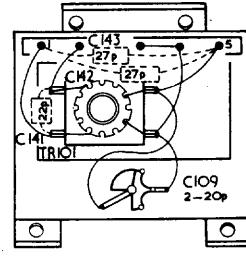
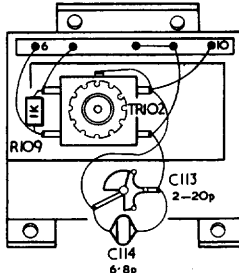
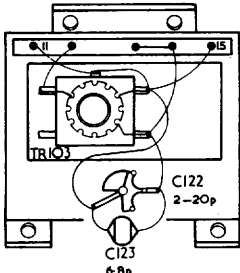
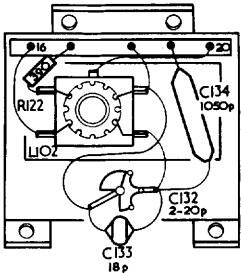

BAND 3

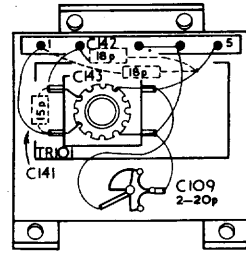
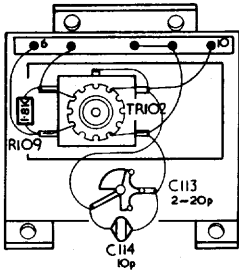
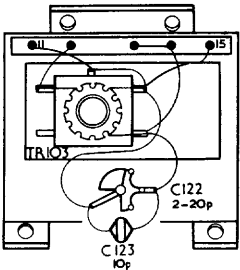
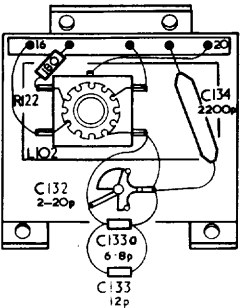

BAND 4

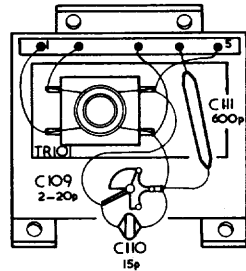
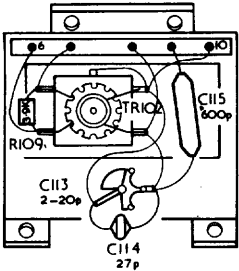
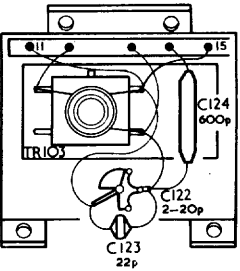
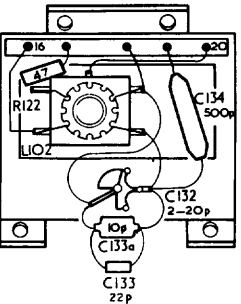

BAND 5

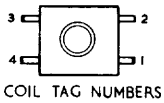
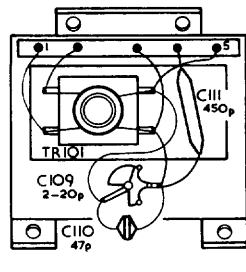
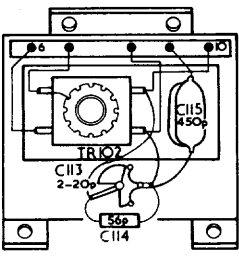
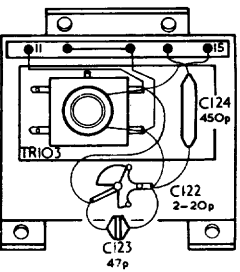
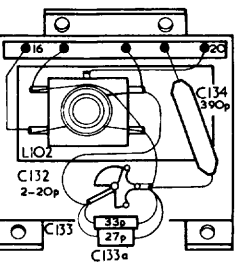

COIL TAG NUMBERS

RECEIVER B40 AP57140/A/B/C.
TURRET SWITCH COMPONENTS:-LAYOUT DIAGRAM.

FIG 2

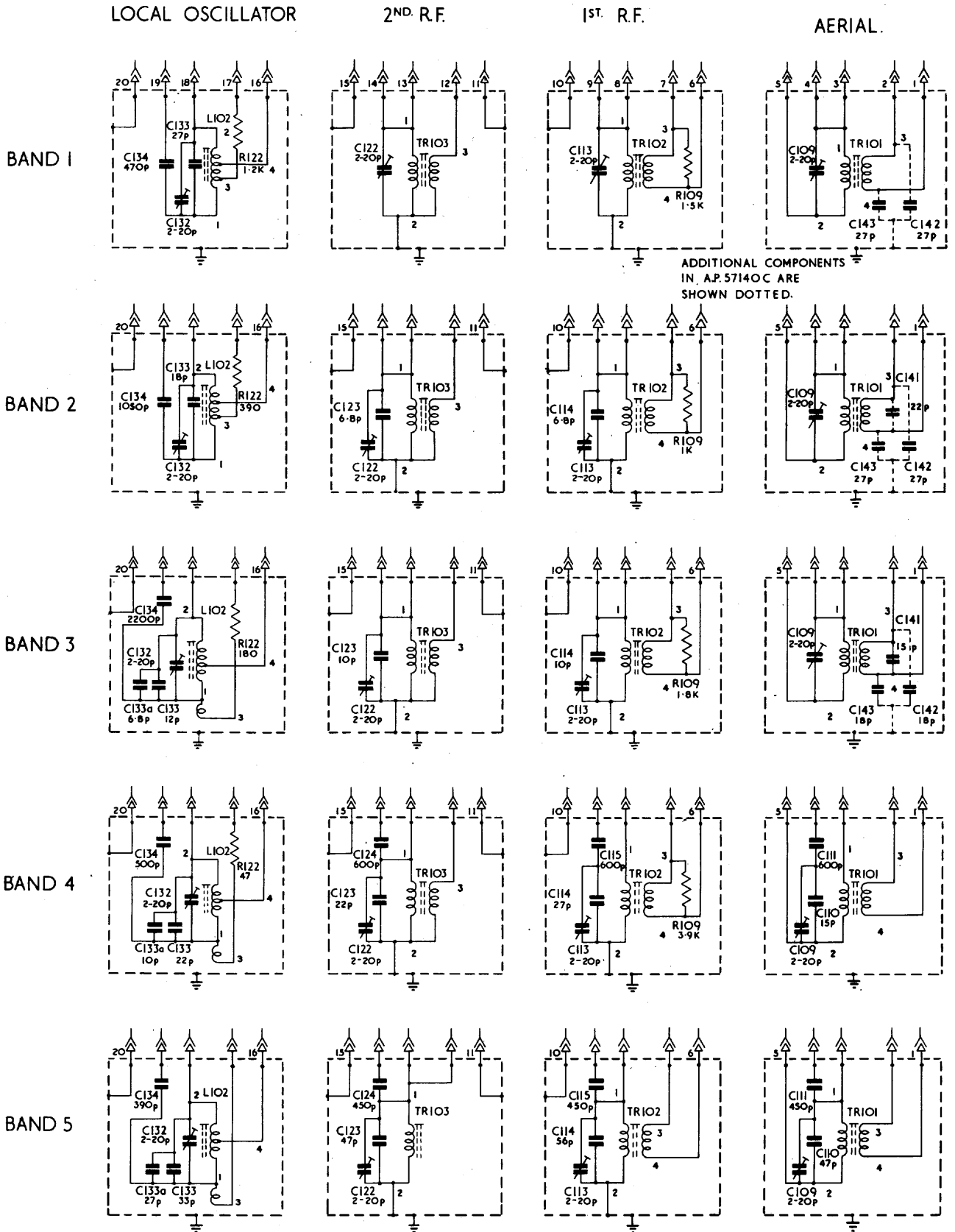

RECEIVER B 40. A.P. 57140/A/B/C.
TURRET SWITCH COMPONENTS. CIRCUIT DIAGRAM.

FIG. 3

R				121	123	124	117	118	116	115	119	120	114	113	111	112	110	101	107	103			
C				138	137	139	136	120	140	127	130	126	129	103	121		118	117	119	131	104	107	108
MISC	LP101-107	RV102	XL101	SW102	L101	TR104		V104		V103						V102							

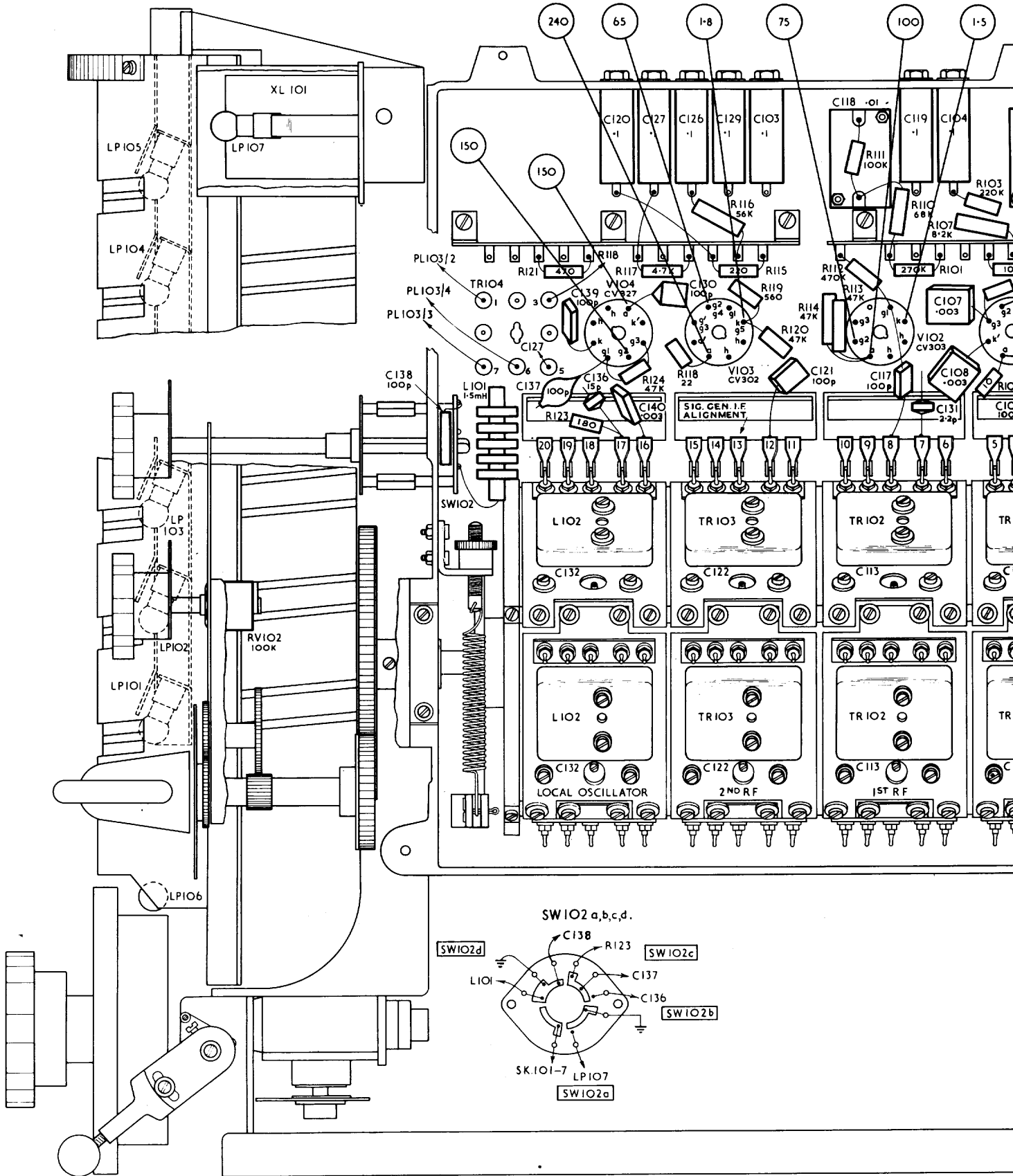

114	113	111	112	110	101	107	103	106	105	108	104	R
118	117	119	131	104	107	108	105	102	101	106		C
V102				V101			M5	PL101	SW101			MISC

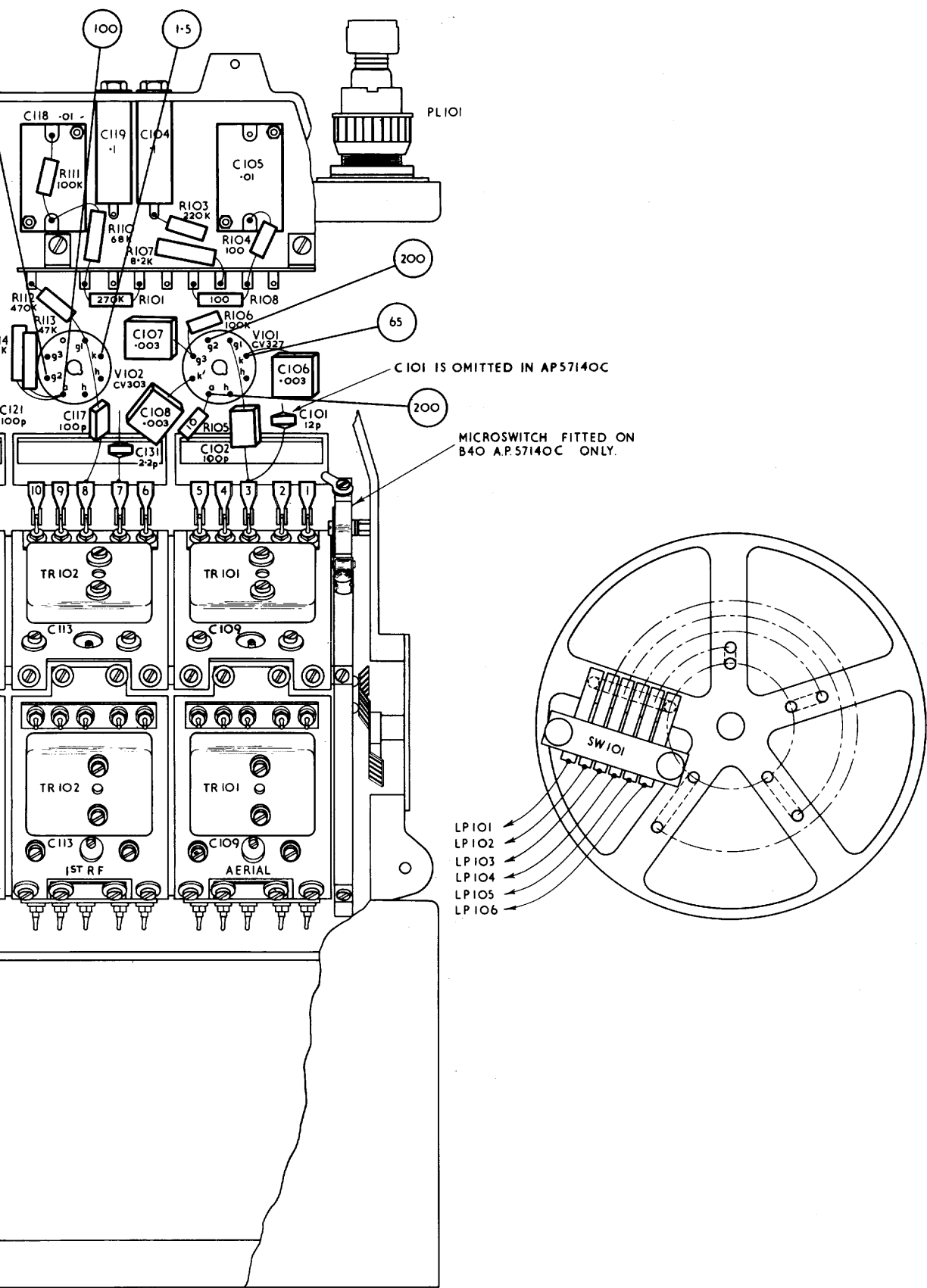

RECEIVER B40 A.P.57140/A/B/C
R.F. UNIT. RIGHT HAND LAYOUT.

FIG. 4

R		101	103	104	105	106	108	109		110	111	112	113	114		116	117	118	120	R
					107						122		115	123		124	121	119		
C	101	102	103	104	105	106	107	108	109	110	111	112	113	114	115	116	117	118	119	120
	141	142	143	109	110	131	132	133	134	135	136	137	138	139	140	141	142	143	144	145
MISC	PLIO1	TRIO1	RVIO2	SWIO1	VIO1				TRIO2			VIO2	TRIO3		VIO3	VIO4	TRIO4	SKIO1	PLIO3	MISC
	SWIO2a	LP IO1-IO7	RV125		SKIO2					LIO2	SWIO2b	XLIO1	SWIO2c		LIO1	SWIO2d				

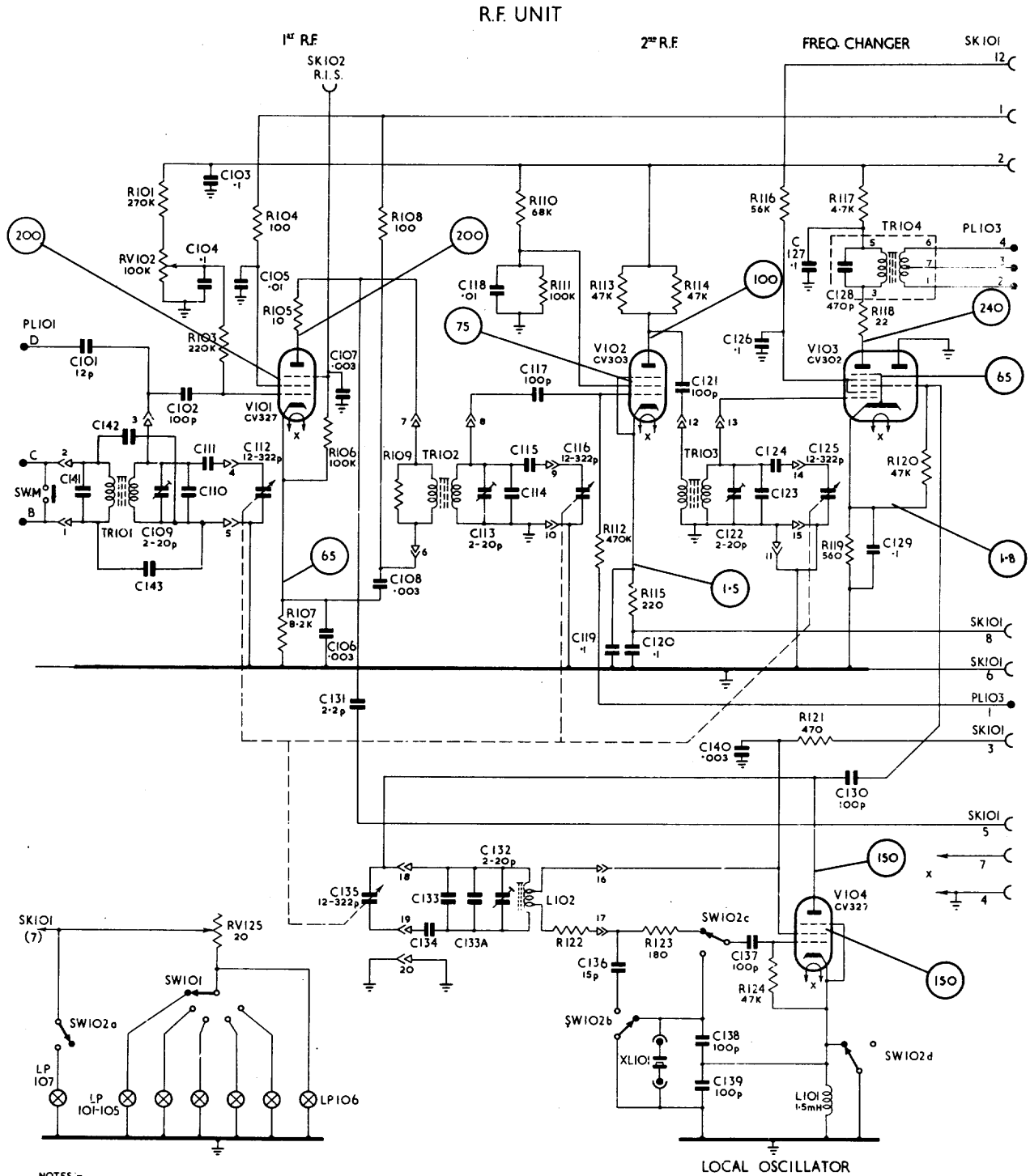

- NOTES:-
1. THE FOLLOWING COMPONENTS ARE ONLY FITTED TO PATT.57140C :- C141, C142, C143 AND SW.M.
 2. THE HIGH IMPEDANCE AERIAL CONNECTION TO PLIO1 D, INCLUDING C101, IS OMITTED IN PATT.57140C
 3. C133A IS FITTED ONLY IN PATT.57140B/C.
 4. REFER TO FIG. 2 PT.3 FOR VALUES OF COMPONENTS IN TURRET COMPARTMENTS

RECEIVER B40. A.P. 57140/A/B/C
R.F. UNIT. CIRCUIT DIAGRAM.

FIG. 5

R	IO1	IO3	IO4	IO5	IO7	IO6	IO8	IO9	IO10	IO11	IO12	IO13	IO14	IO16	IO17	IO20	R									
C	IO1 141	IO3 142	IO4 143	IO5 102	IO7 104	IO8 111	IO9 112	IO10 106	IO11 131	IO12 135	IO13 134	IO14 133	IO15 133a	IO16 132	IO17 119	IO20 120	IO21 121	IO22 122	IO23 124	IO24 127	IO25 128	IO26 129	IO27 125	IO28 130	C	
MISC	PLIO1 SWM SWIO2a	RVIO2 TRIO1 LP IO1-IO7	RVIO2 LP IO1-IO7	RVIO2 RV125	RVIO2 RV125	RVIO2 RV125	RVIO2 RV125	RVIO2 RV125	RVIO2 RV125	RVIO2 RV125	RVIO2 RV125	RVIO2 RV125	RVIO2 RV125	RVIO2 RV125	RVIO2 RV125	RVIO2 RV125	RVIO2 RV125	RVIO2 RV125	RVIO2 RV125	RVIO2 RV125	RVIO2 RV125	RVIO2 RV125	RVIO2 RV125	RVIO2 RV125	RVIO2 RV125	MISC

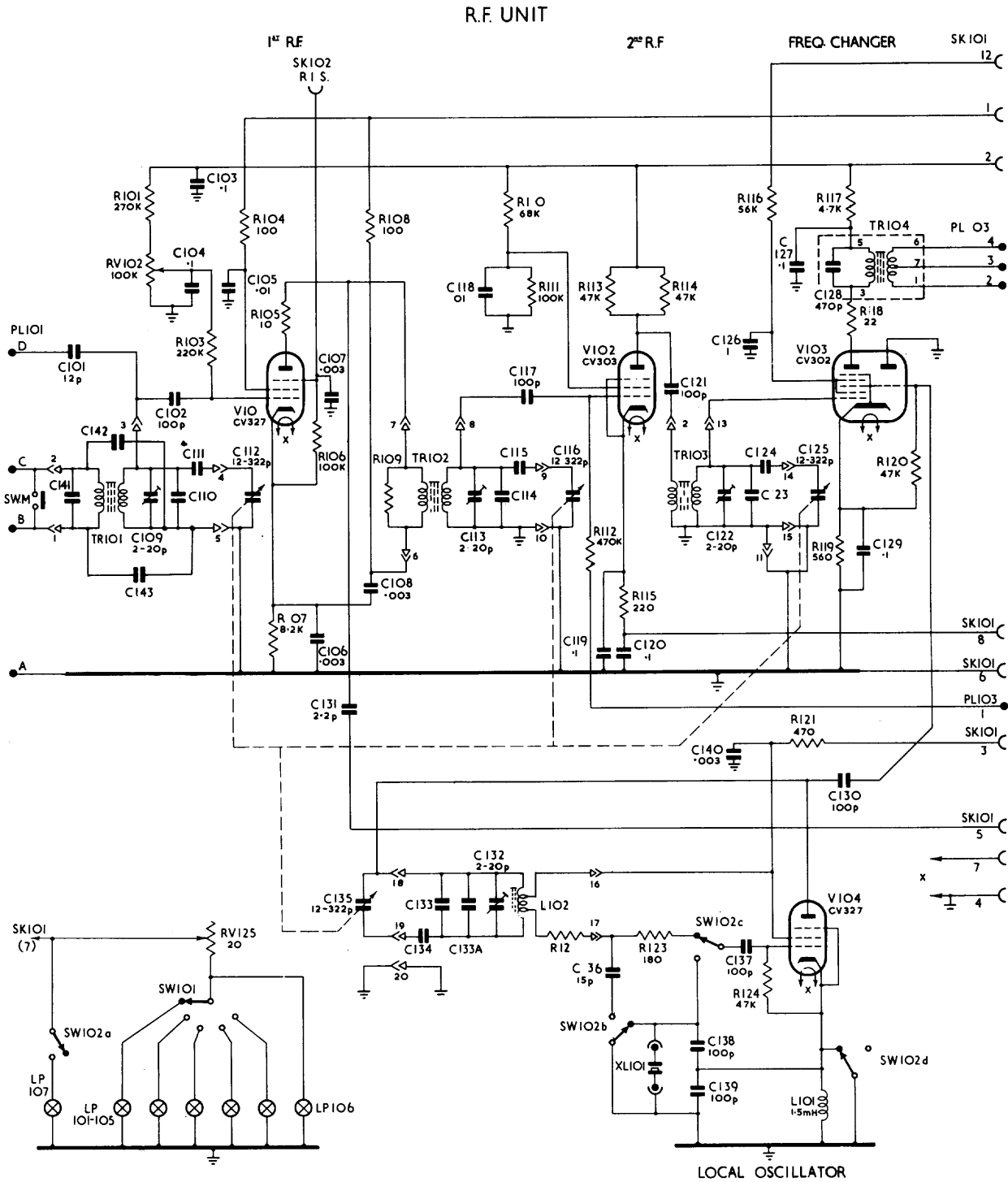

NOTES -

1. THE FOLLOWING COMPONENTS ARE ONLY FITTED TO PATT. 57140C - C14, C42, C43 AND SWM
2. THE HIGH IMPEDANCE AERIAL CONNECT ON TO PLIO1 INCLUDING C101, IS OMITTED IN PATT. 57140B/C
3. C133A IS FITTED ONLY IN PATT. 57140B/C
4. REFER TO F.C. 2 PT. 3 FOR VALUES OF COMPONENTS IN TURRET COMPARTMENT

RECEIVER B40. A.P 57140/A/B/C
R.F. UNIT. CIRCUIT DIAGRAM.

FIG 6

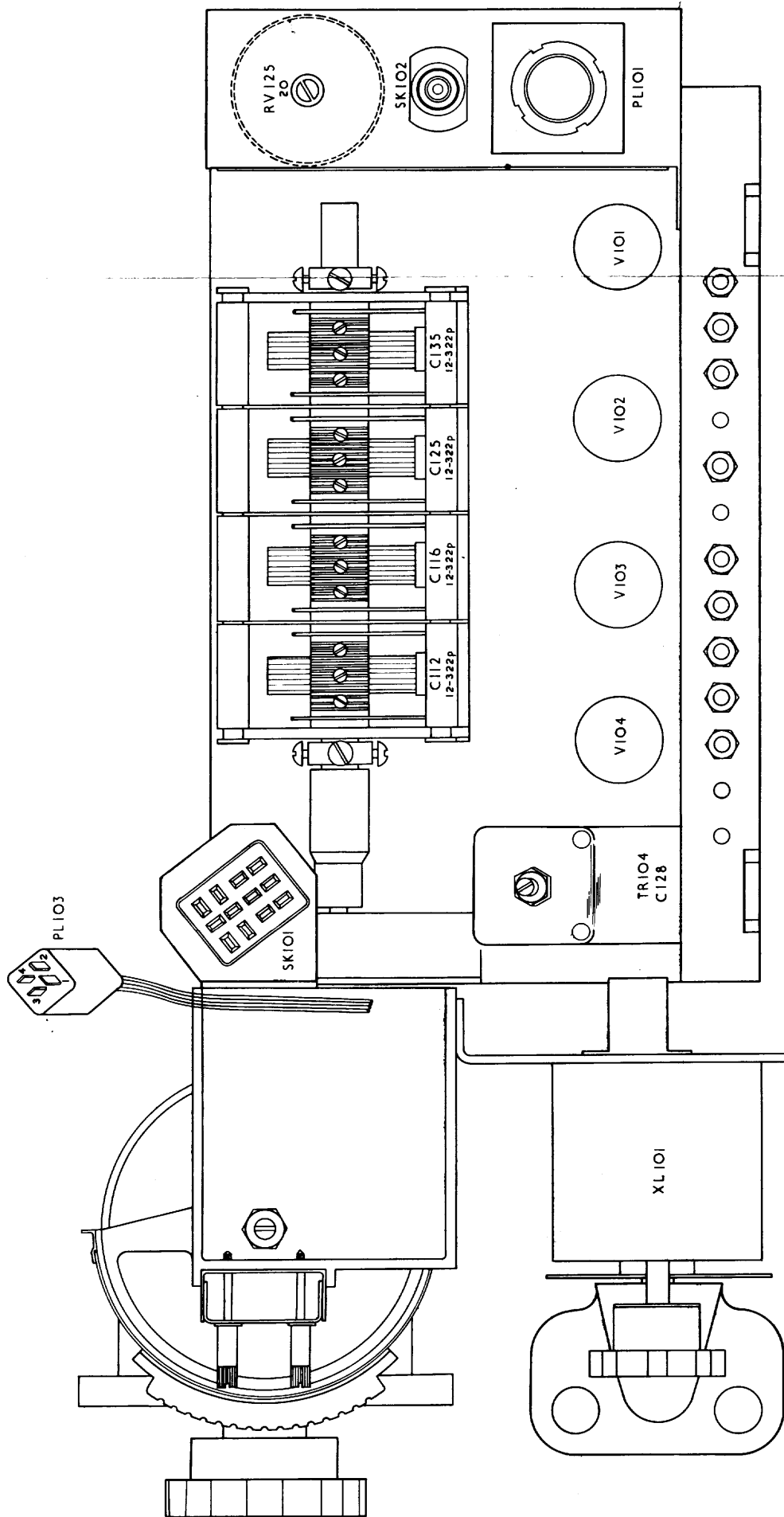

RECEIVER B40
R.F. UNIT.TOP LAYOUT

A.P.57140/A/B/C.

COMPONENTS LIST RECEIVER B40

PATTERNS 57140/A/B/C

RF UNIT

CAPACITORS

Ref.	A.P. or Joint-Service Cat. No.	Value	Tol.	Rating	Remarks
C101	Z131175	12 pF	10%	500V	Not in AP.57140C
C102	Z123194	100 pF	20%	350V	
C103	Z115095	0.1 μ F	20%	350V	
C104	Z115095	0.1 μ F	20%	350V	
C105	Z124407	0.01 μ F	20%	350V	
C106	Z124477	0.003 μ F	20%	350V	
C107	Z124477	0.003 μ F	20%	350V	
C108	Z124477	0.003 μ F	20%	350V	Variable Band 4
C109	≡ Z160009	4-18 pF	10%		
C110	Z131178	15 pF	10%	500V	
C110	Z131194	47 pF	5%	500V	Band 5
C111	Z125666	600 pF	5%	350V	Band 4
C111	Z125664	450 pF	5%	350V	Band 5
C112	A.P. 60189	12-322 pF	1/2%		Ganged Cap. Sect.
C113	≡ Z160009	4-18 pF	10%		Variable
C114	Z131169	6.8 pF	10%	500V	Band 2
C114	Z131058	10 pF	10%	500V	Band 3
C114	Z131186	27 pF	10%	500V	Band 4
C114	Z131197	56 pF	5%	500V	Band 5
C115	Z125666	600 pF	5%	350V	Band 4
C115	Z125664	450 pF	5%	350V	Band 5
C116	A.P. 60189	12-322 pF	1/2%		Ganged Cap. Sect.
C117	Z123194	100 pF	20%	350V	
C118	Z124407	0.01 μ F	20%	350V	
C119	Z115095	0.1 μ F	20%	350V	
C120	Z115095	0.1 μ F	20%	350V	
C121	Z123194	100 pF	20%	350V	
C122	≡ Z160009	4-18 pF	10%		Variable
C123	Z131169	6.8 pF	10%	500V	Band 2
C123	Z131058	10 pF	10%	500V	Band 3
C123	Z131184	22 pF	10%	500V	Band 4
C123	Z131194	47 pF	10%	500V	Band 5
C124	Z125664	450 pF	5%	350V	Band 5
C124	Z125666	600 pF	5%	350V	Band 4
C125	A.P. 60189	12-322 pF	1/2%		Ganged Cap. Sect.

≡ Replacement Component.

Ref.	A.P. or Joint-Service Cat. No.	Value	Tol.	Rating	Remarks
C126	Z115095	0.1 μ F	20%	350V	
C127	Z115095	0.1 μ F	20%	350V	
C128	Z125665	470 pF	5%	350V	
C129	Z115095	0.1 μ F	20%	350V	
C130	Z131206	100 pF	10%	500V	
C131	Z131165	2.2 pF	0.5 pF	500V	
C132	Z160009	4-18 pF	10%		Variable
C133	Z131186	27 pF	10%	500V	Band 1
C133	Z131181	18 pF	10%	500V	Band 2
C134	Z125476	470 pF	5%	350V	Band 1
C134	Z126350	1050 pF	5%	350V	Band 2
C134	Z126351	2200 pF	10%	350V	Band 3
C134	W6424	500 pF	5%	350V	Band 4
C134	Z125450	390 pF	5%	350V	Band 5
C135	60189	12-322 pF			Ganged Cap. Sect.
C136	Z131178	15 pF	10%	500V	
C137	Z130206	100 pF	10%	350V	
C138	Z123194	100 pF	20%	350V	
C139	Z123194	100 pF	20%	350V	
C140	Z124477	0.003 μ F	20%	350V	

Ref.	A.P. or Joint-Service Cat. No.	Value	Tol.	Rating	Remarks
C133	Z132244	12 pF	10%	500V	Band 3
C133	Z132276	22 pF	5%	350V	Band 4
C133	Z125608	33 pF	5%	500V	Band 5
C133A	Z132268	6.8 pF	10%	500V	Band 3
C133A	Z125704	10 pF	5%	500V	Band 4
C133A	Z132279	27 pF	5%	350V	Band 5

≠ Replacement Component.

PATTERN 57140C ONLY

Ref.	A.P. or Joint-Service Cat. No.	Value	Tol.	Rating	Remarks
C141	Z132277	22 pF	10%	500V	Band 2
C141	Z132073	15 pF	10%	500V	Band 3
C142	Z132280	27 pF	10%	500V	Bands 1/2
C142	Z132274	18 pF	10%	500V	Band 3
C143	Z132280	27 pF	10%	500V	Bands 1/2
C143	Z132274	18 pF	10%	500V	Band 3

RESISTORS

Ref.	A.P. or Joint-Service Cat. No.	Value	Tol.	Rating	Remarks
R101	Z223092	270k ohms	10%	$\frac{1}{2}$ W	Variable
RV102	51464A	100k ohms		$\frac{1}{4}$ W	
R103	Z223080	220k ohms		$\frac{1}{2}$ W	
R104	Z221110	100 ohms		$\frac{1}{2}$ W	
R105	Z221002	10 ohms		$\frac{1}{2}$ W	
R106	Z223038	100k ohms		$\frac{1}{2}$ W	Band 1 Band 2
R107	Z222123	8.2k ohms		$\frac{3}{4}$ W	
R108	Z221110	100 ohms		$\frac{1}{2}$ W	
R109	Z222026	1.5k ohms		$\frac{1}{2}$ W	
R109	Z222005	1k ohm		$\frac{1}{2}$ W	
R109	Z222038	1.8k ohms		$\frac{1}{2}$ W	Band 3 Band 4
R109	Z222080	3.9k ohms		$\frac{1}{2}$ W	
R110	Z223018	68k ohms		$\frac{3}{4}$ W	
R111	Z223038	100k ohms		$\frac{1}{2}$ W	
R112	Z223122	470k ohms		$\frac{1}{2}$ W	
R113	Z222216	4.7k ohms		$\frac{3}{4}$ W	Band 1
R114	Z222216	4.7k ohms		$\frac{3}{4}$ W	
R115	Z221152	220 ohms	$\frac{1}{2}$ W		
R116	Z223009	56k ohms	$\frac{3}{4}$ W		
R117	Z222089	4.7k ohms	$\frac{1}{2}$ W		
R118	Z221026	22 ohms	$\frac{1}{2}$ W		
R119	Z221206	560 ohms	$\frac{1}{2}$ W		
R120	Z222215	4.7k ohms	$\frac{1}{2}$ W		
R121	Z221194	470 ohms	$\frac{1}{2}$ W		
R122	Z222017	1.2k ohms	$\frac{1}{2}$ W		
R122	Z221185	390 ohms	$\frac{1}{2}$ W	Band 2	
R122	Z221143	180 ohms	$\frac{1}{2}$ W		
R122	Z221068	47 ohms	$\frac{1}{2}$ W	Band 3 Band 4	
R123	Z221143	180 ohms	$\frac{1}{2}$ W		
R124	Z222215	4.7k ohms	$\frac{1}{2}$ W		
RV125	60480A	20 ohms	2.5W	Variable	

TRANSFORMERS

Ref.	Pattern No.	Description
TR101 bands 1 - 5	Replace with 5905-A.P.184026/7/8/9/30	Transformer R.F. Aerial
TR102/3	-	Transformer 1st & 2nd R.F.
TR104	-	Transformer I.F.- I.F. Output

INDUCTORS

Ref.	Description
L101	Choke 1.5 mH - Oscillator -
L102	Coil, Tuned - Oscillator -

PLUGS AND SOCKETS

Ref.	A.P. or Joint-Service Cat. No.	Description
PL101	Z560070	Plug 4 pin - Aerial (Mk. 4)
PL103	57771	Plug 4 pin - IF Output
SK101	60156	Socket 12 way - RF/IF Unit inter-connection
SK102	60451	Socket Co-axial - R. I. S.

LAMPS

Ref.	J.S. Cat. No.	Description
LP101-107	X951225	Pilot Lamps, 6.5V., 0.3A M.E.S.

SWITCHES

Ref.	Pattern	Description
SW101	65638	Switch, Lamps
SW102		Switch, Wafer, Crystal
SW.M		Microswitch - B40C only -

CRYSTAL

Ref.	Pattern	Description
XL101	As required	Crystal, 2 pin, - Local oscillator -

FIG. 7

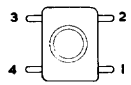
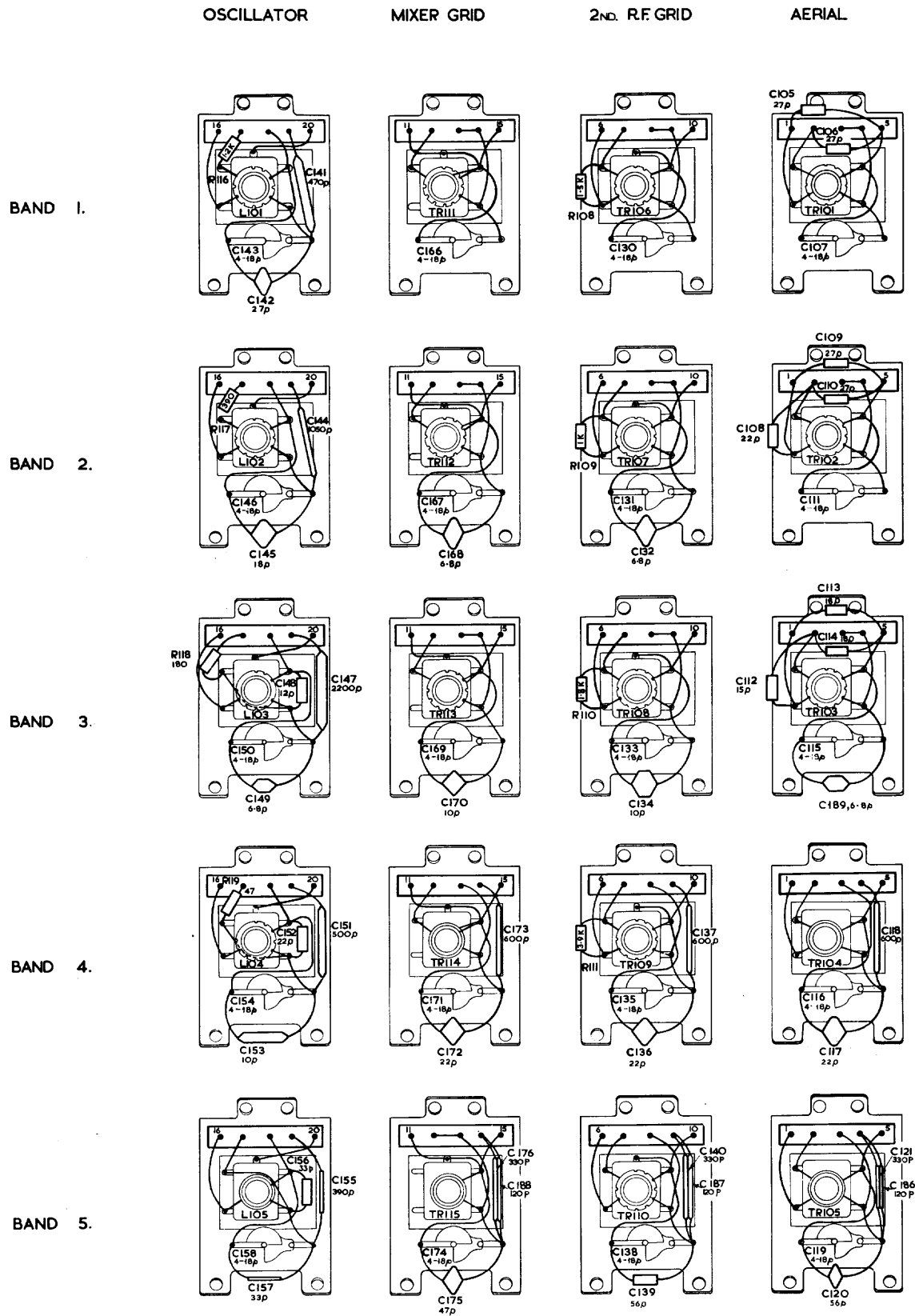

COIL TAG NUMBERS

RECEIVER B40 A.P. 57140 D.
TURRET SWITCH COMPONENTS. LAYOUT DIAGRAM.

FIG. 8

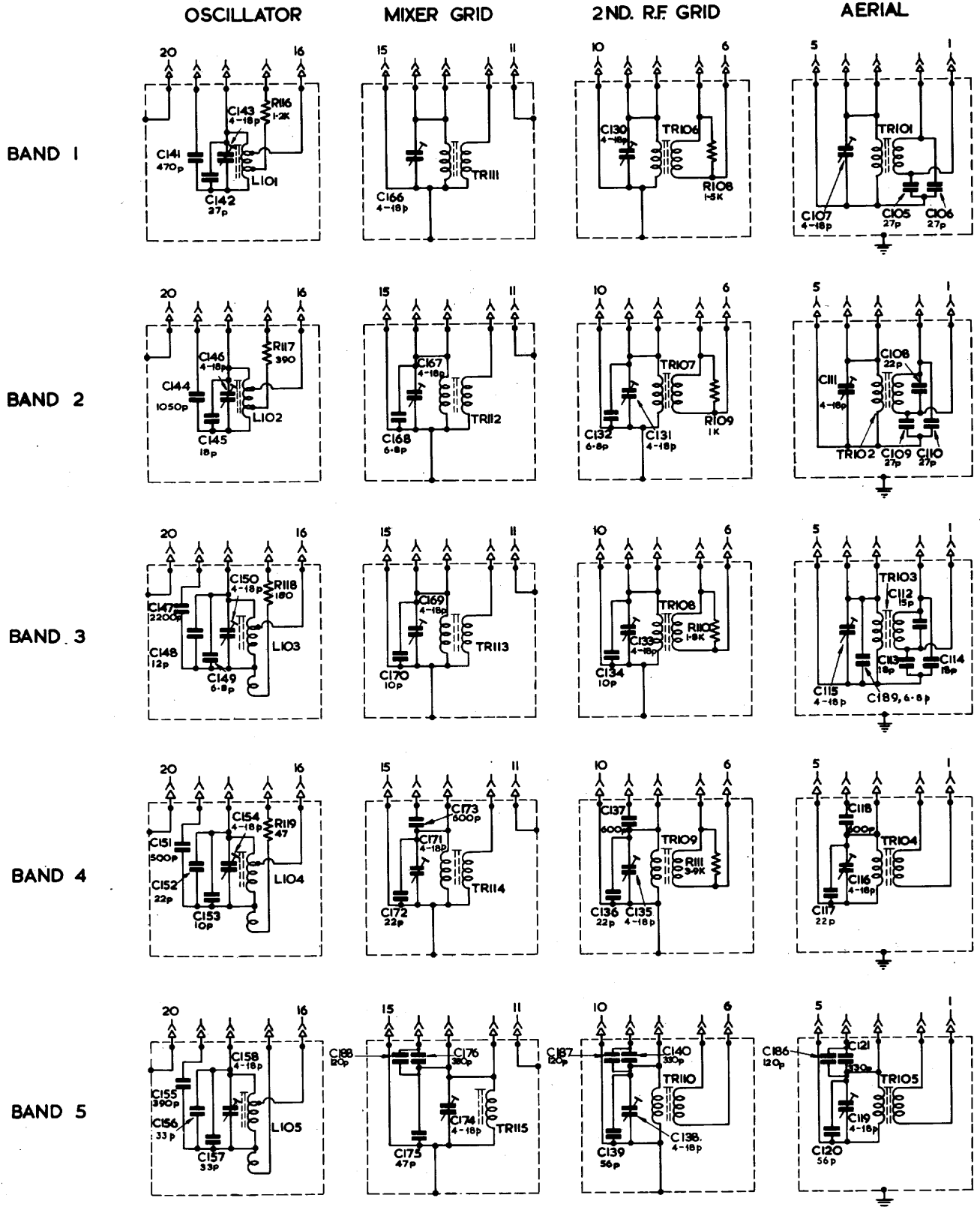

RECEIVER B40 A.P. 57140 D.
TURRET SWITCH COMPONENTS. CIRCUIT DIAGRAM.

106	105	107	104	122	102	101	103	123	124	125	127	128	129	130	160	162	161	163	164	179	165	166	177	182	184	C	
					101	102	103	105	106	130	107	108	112	113	115	122	114	120	123	126	125	127	128	183	185	R	
VIO2	LPIO1	LPIO7	RVIO1	MRI	VIO1	SKIO1	LIO1	TRIO6	SWIO3b	VIO2	XLIO1	TRIII	VIO3	TRII6	SKIO3	PLIO2	MISC										
VIO3a	TRIO1	RVIO2																									

R.F. UNIT

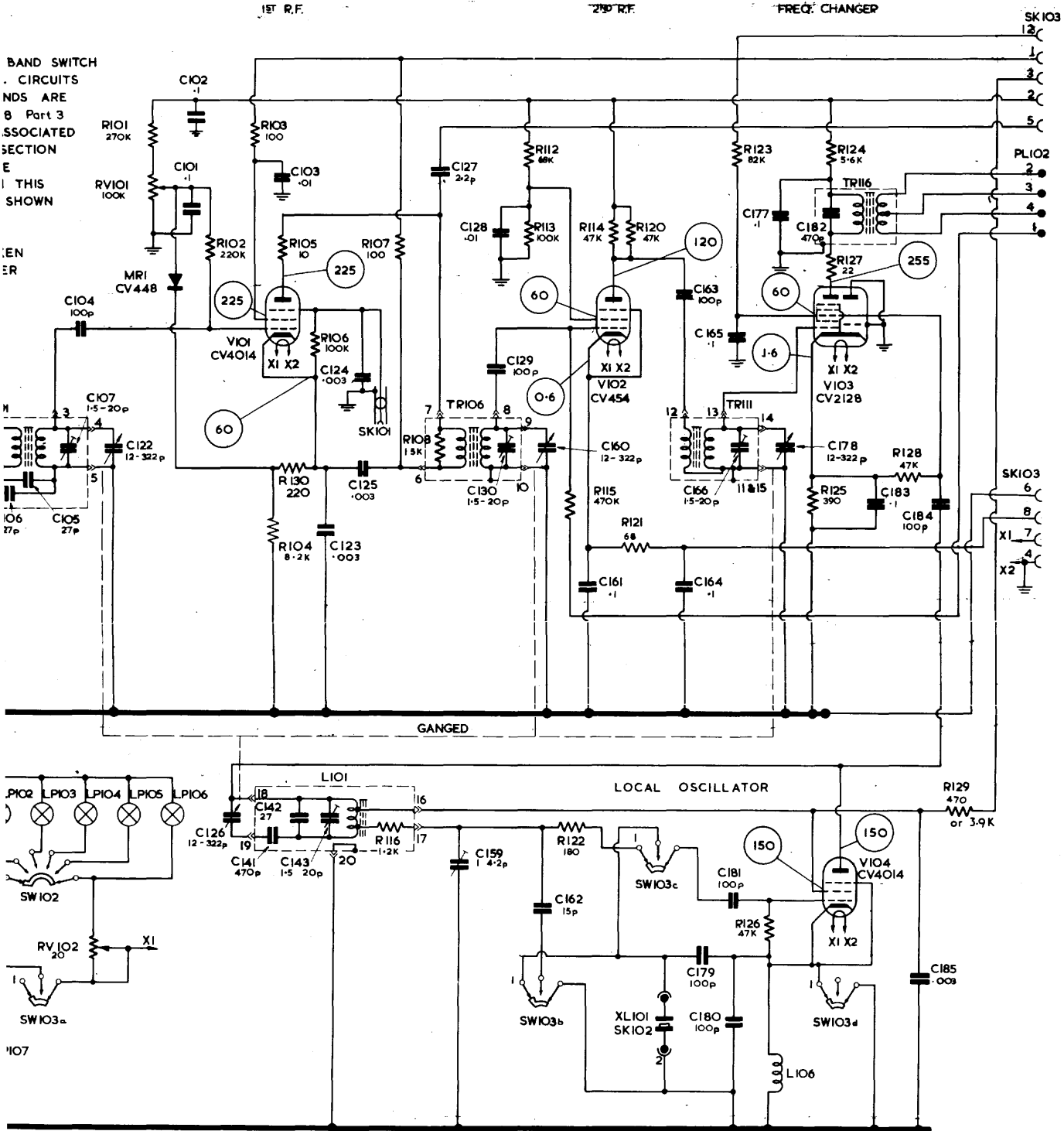

RECEIVER B40 A.P. 57140D
R.F. UNIT CIRCUIT DIAGRAM

CAPACITORS (Cont'd.)

Ref.	A.P. or Joint-Service Cat. No.	Value	Tol.	Rating	Remarks
C176	012-7105	330 pF	2%	750V	Stud mounting Ganged Cap. Sect.
C177	011-5905	0.1 μ F	20%	350V	
C178	A.P. 60189	12-322 pF	1%		
C179	012-3165	100 pF	20%	750V	
C180	012-3165	100 pF	20%	750V	
C181	012-7113	100 pF	2%	750V	Stud mounting
C182	012-3984	470 pF	5%	750V	
C183	011-5095	0.1 μ F	20%	350V	
C184	012-7113	100 pF	2%	750V	
C185	911-5674	0.003 μ F	20%	350V	
C186	012-3926	120 pF	2%	750V	
C187	012-3926	120 pF	2%	750V	
C188	012-3926	120 pF	2%	750V	
C189	012-7087	6.8 pF	0.5 pF	750V	

RESISTORS

Ref.	A.P. or Joint-Service Cat. No.	Value	Tol.	Rating	Remarks
R101	022-3091	270k ohms	10%	$\frac{1}{2}$ W	
R102	022-3079	220k ohms	10%	$\frac{1}{2}$ W	
R103	022-1109	100 ohms	10%	$\frac{1}{2}$ W	
R104	022-2123	8.2k ohms	10%	$\frac{3}{4}$ W	
R105	022-1002	10 ohms	10%	$\frac{1}{2}$ W	
R106	022-3037	100k ohms	10%	$\frac{1}{2}$ W	
R107	022-1109	100 ohms	10%	$\frac{1}{2}$ W	
R108	022-2025	1.5k ohms	10%	$\frac{1}{2}$ W	
R109	022-2004	1k ohm	10%	$\frac{1}{2}$ W	
R110	022-2037	1.8k ohms	10%	$\frac{1}{2}$ W	
R111	022-2079	3.9k ohms	10%	$\frac{1}{2}$ W	
R112	022-3018	68k ohms	10%	$\frac{3}{4}$ W	
R113	022-3037	100k ohms	10%	$\frac{1}{2}$ W	
R114	022-2216	47k ohms	10%	$\frac{3}{4}$ W	
R115	022-3121	470k ohms	10%	$\frac{1}{2}$ W	
R116	022-2016	1.2k ohms	10%	$\frac{1}{2}$ W	
R117	022-1184	390 ohms	10%	$\frac{1}{2}$ W	
R118	022-1142	180 ohms	10%	$\frac{1}{2}$ W	
R119	022-1067	47 ohms	10%	$\frac{1}{2}$ W	
R120	022-2216	47k ohms	10%	$\frac{1}{2}$ W	

RESISTORS (Cont'd.)

Ref.	A.P. or Joint-Service Cat. No.	Value	Tol.	Rating	Remarks
R121	022-1088	68 ohms		$\frac{1}{2}$ W	
R122	022-1142	180 ohms		$\frac{1}{2}$ W	
R123	022-3030	82k ohms		$\frac{1}{2}$ W	
R124	022-2100	5.6k ohms		$\frac{1}{2}$ W	
R125	022-1184	390 ohms		$\frac{1}{2}$ W	
R126	022-2214	4.7k ohms		$\frac{1}{2}$ W	
R127	022-1026	22 ohms		$\frac{1}{2}$ W	
R128	022-2214	4.7k ohms		$\frac{1}{2}$ W	
R129	022-2079	470 ohms		$\frac{1}{2}$ W	
R130	022-1151	220 ohms		$\frac{1}{2}$ W	

VARIABLE RESISTORS

Ref.	A.P. or Joint-Service Cat. No.	Value	Tol.	Rating	Remarks
RV101	900-4942	100k ohms	20%	0.1W	Anti-cross-mod. Lamps, Brilliance
RV102	580-3198	20 ohms	10%	2.5W	

TRANSFORMERS

Ref.	Pattern No.	Description
TR101	5905-A.P.184026	R.F. Transformer Band 1
TR102	5905-A.P.184027	R.F. Transformer Band 2
TR103	5905-A.P.184028	R.F. Transformer Band 3
TR104	5905-A.P.184029	R.F. Transformer Band 4
TR105	5905-A.P.184030	R.F. Transformer Band 5
TR106	5905-A.P.106099	R.F. Transformers 1st and 2nd R.F. Tuned, Bands 1 to 5
TR107	5905-A.P.106100	R.F. Transformers 1st and 2nd R.F. Tuned, Bands 1 to 5
TR108	5905-A.P.106108	R.F. Transformers 1st and 2nd R.F. Tuned, Bands 1 to 5
TR109	5905-A.P.106109	R.F. Transformers 1st and 2nd R.F. Tuned, Bands 1 to 5
TR110	5905-A.P.106110	R.F. Transformers 1st and 2nd R.F. Tuned, Bands 1 to 5
TR111	5905-A.P.106101	R.F. Transformers 1st and 2nd R.F. Tuned, Bands 1 to 5
TR112	5905-A.P.106102	R.F. Transformers 1st and 2nd R.F. Tuned, Bands 1 to 5
TR113	5905-A.P.106111	R.F. Transformers 1st and 2nd R.F. Tuned, Bands 1 to 5
TR114	5905-A.P.106112	R.F. Transformers 1st and 2nd R.F. Tuned, Bands 1 to 5
TR115	5905-A.P.106113	R.F. Transformers 1st and 2nd R.F. Tuned, Bands 1 to 5
TR116	5950-A.P.106117	I.F. Transformer

INDUCTORS

Ref.	A.P. or Joint-Service Cat. No.	Description
L101	A.P.106103	Coil, Tuned - Local Oscillator
L102	A.P.106104	Coil, Tuned - Local Oscillator
L103	A.P.106114	Coil, Tuned - Local Oscillator
L104	A.P.106115	Coil, Tuned - Local Oscillator
L105	A.P.106116	Coil, Tuned - Local Oscillator
L106	A.P.106151	Choke, 1.5 mH - Local Oscillator

PLUGS AND SOCKETS

Ref.	A.P. or Joint-Service Cat. No.	Description
PL101	999-3526	4 Pin, Mark 4 - Aerial Input
PL102	972-8183	4 Pin - Interconnecting (RF/IF Units)
SK101	580-3620	Coaxial - R.I.S.
SK102	A46852	Crystal - Local Oscillator
SK103	972-8233	12 Pin - Interconnection (RF/IF Units)

LAMPS

Ref.	A.P. or Joint-Service Cat. No.	Description
LP101 to LP107	995-1225	Pilot Lamps, 6.5V 0.3A M.E.S.

SWITCHES

Ref.	A.P. or Joint-Service Cat. No.	Description
SW101 SW102 SW103	051-0080	Micro Switch Switch Lamps Crystal Switch

CRYSTALS

Ref.	A.P. or Joint-Service Cat. No.	Description
XL101 MR1	CV7130 037-2373	Crystal - Local Oscillator Crystal - Rectifier

FIG. 10

6	115	119	120	114	113	111	112	110	101	107	103	106	105	108	104	R
129	103	121		118	117	119	131	104	107	108	105	102	101	106	C	
V103		V102		V101		MS	PL101				SW101				MISC	

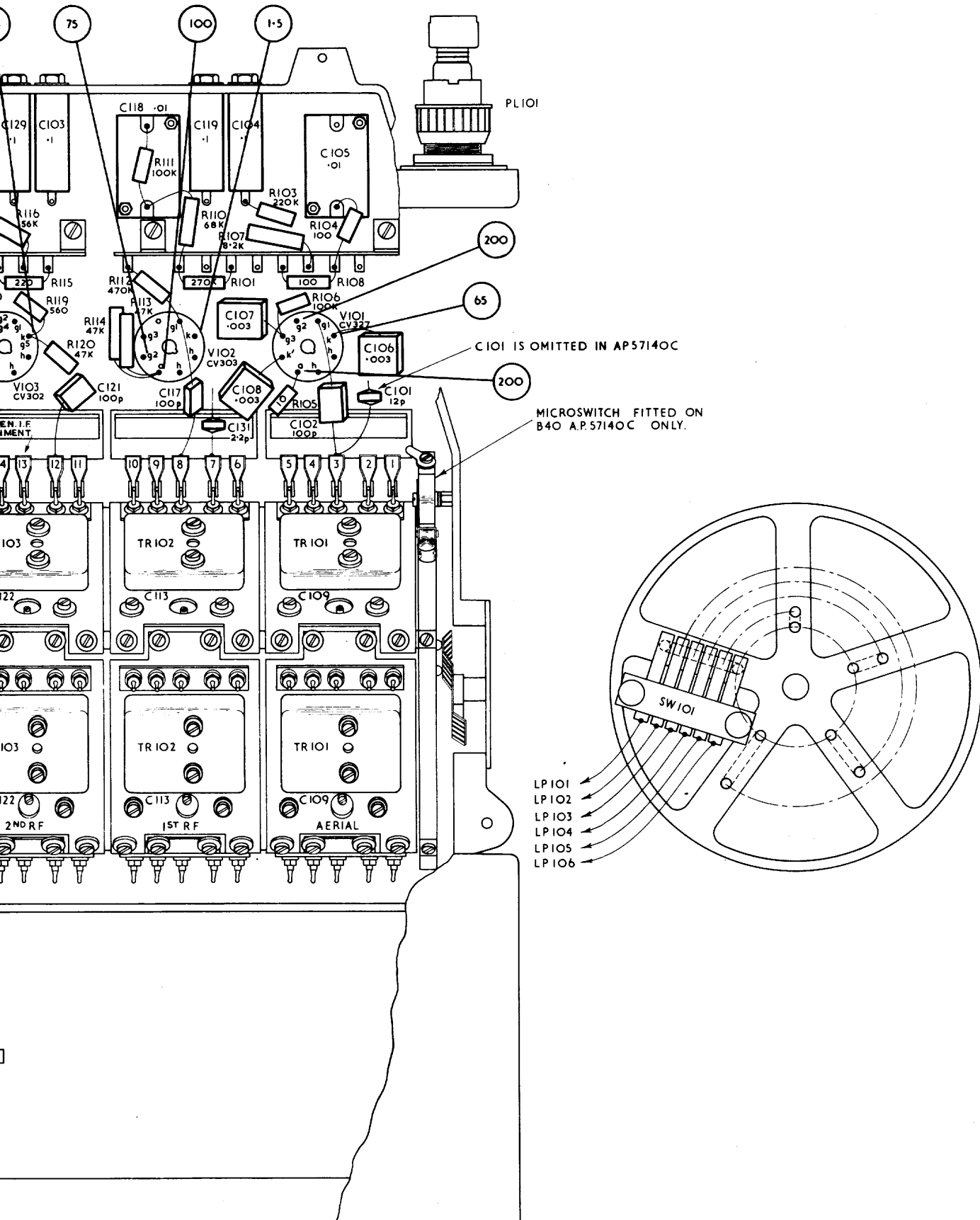

RECEIVER B40 A.P.57140/A/B/C
R.F. UNIT. RIGHT HAND LAYOUT.

R	121	123	124	117	118	116	115	119	120					
C	138			137	139	136	120	140	127	130	126	129	103	12
MISC	LPIO1-107		RV102	XL101	SW102		L101	TR104	V104		V103			

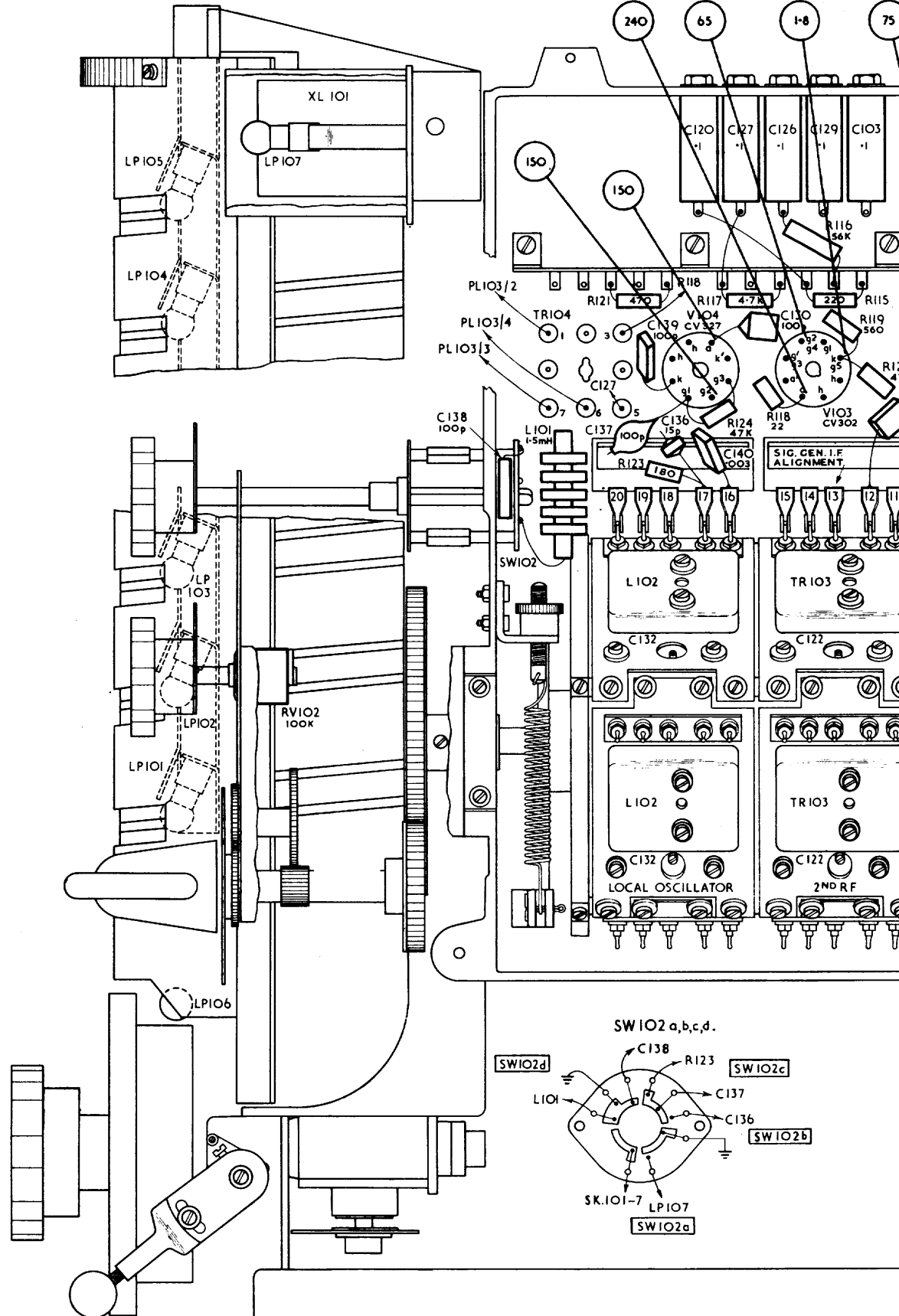

COMPONENTS LIST, RECEIVER B40A.P. 57140DR.F. UNITCAPACITORS

Ref.	A.P. or Joint-Service Cat. No.	Value	Tol.	Rating	Remarks
C101	011-5095	0.1 μ F	20%	350V	Stud mounting
C102	011-5095	0.1 μ F	20%	350V	Stud mounting
C103	012-4407	0.01 μ F	20%	350V	
C104	012-3165	100 pF	20%	750V	
C105	012-7099	27 pF	10%	750V	
C106	012-7099	27 pF	5%	750V	
C107	016-0009	4-18 pF	10%		Variable
C108	012-7097	22 pF	5%	750V	
C109	012-7099	27 pF	5%	750V	
C110	012-7099	27 pF	5%	750V	
C111	016-0009	4-18 pF	10%		Variable
C112	012-7093	15 pF	5%	750V	
C113	012-7095	18 pF	5%	750V	
C114	012-7095	18 pF	5%	750V	
C115	016-0009	4-18 pF	10%		Variable
C116	016-0009	4-18 pF	10%		Variable
C117	012-7097	22 pF	5%	750V	
C118	972-9507	600 pF	5%	350V	
C119	016-0009	4-18 pF	10%		Variable
C120	012-7107	56 pF	2%	750V	
C121	012-3941	330 pF	2%	750V	
C122	A.P.60189	12-322 pF	$\frac{1}{2}$ %		Ganged Cap. Sect.
C123	911-5674	0.003 μ F	20%	350V	
C124	911-5674	0.003 μ F	20%	350V	
C125	911-5674	0.003 μ F	20%	350V	
C126	A.P.60189	12-322 pF	$\frac{1}{2}$ %		Ganged Cap. Sect.
C127	012-7081	2.2 pF	0.5 pF	750V	
C128	012-4407	0.01 μ F	20%	350V	
C129	012-3165	100 pF	20%	750V	
C130	016-0009	4-18 pF	10%		Variable
C131	016-0009	4-18 pF	10%		Variable
C132	012-6772	6.8 pF	0.5 pF	750V	
C133	016-0009	4-18 pF	10%		Variable
C134	012-7089	10 pF	0.5 pF	750V	
C135	016-0009	4-18 pF	10%		Variable

FIG. 11

R	234	230 231	216 210	207	203	226 225	R
C	233	227	219 215 214	212 211	209 217 208 205 223	218 202	203
	213	212	234 235 224 216 226	209 211	208 204	220 221	238 230
MISC	SK203 SK202	232	228 229 221 222	207	206 203	222	SW203 SW205
	XL201	231	215 214 213 212 211 210 209 208 207	205	204 203 202 201	221	RV220 RV224
	SW204	230	228 227	218	208 204	222	SW202 a, h, i
	SW202 m, q	229	225 226	209 207	208 204	223	LS201 PL205
	SW201 e, e-9	228	224 226	209 207	208 204	223	V205
	SW201 b	227	223 224	209 207	208 204	223	TR204 PL201
	SW201 a	226	222 223	209 207	208 204	223	SK201
	SW202 a, c, e-9	225	221 222	209 207	208 204	223	SK201
	SW201 c	224	220 221	209 207	208 204	223	SK201
	SW201 d, h, i	223	219 223	209 207	208 204	223	SK201
	SW201 e	222	218 227	209 207	208 204	223	SK201
	SW201 f	221	217 218	209 207	208 204	223	SK201
	SW201 g	220	216 217	209 207	208 204	223	SK201
	SW201 h	219	215 216	209 207	208 204	223	SK201
	SW201 i	218	214 215	209 207	208 204	223	SK201
	SW201 j	217	213 214	209 207	208 204	223	SK201
	SW201 k	216	212 213	209 207	208 204	223	SK201
	SW201 l	215	211 212	209 207	208 204	223	SK201
	SW201 m	214	210 211	209 207	208 204	223	SK201
	SW201 n	213	209 210	209 207	208 204	223	SK201
	SW201 o	212	208 209	209 207	208 204	223	SK201
	SW201 p	211	207 208	209 207	208 204	223	SK201
	SW201 q	210	206 207	209 207	208 204	223	SK201
	SW201 r	209	205 206	209 207	208 204	223	SK201
	SW201 s	208	204 205	209 207	208 204	223	SK201
	SW201 t	207	203 204	209 207	208 204	223	SK201
	SW201 u	206	202 203	209 207	208 204	223	SK201
	SW201 v	205	201 202	209 207	208 204	223	SK201
	SW201 w	204	200 201	209 207	208 204	223	SK201
	SW201 x	203	199 200	209 207	208 204	223	SK201
	SW201 y	202	198 199	209 207	208 204	223	SK201
	SW201 z	201	197 198	209 207	208 204	223	SK201

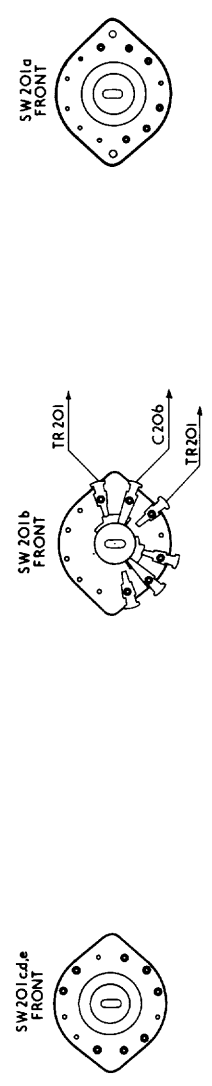
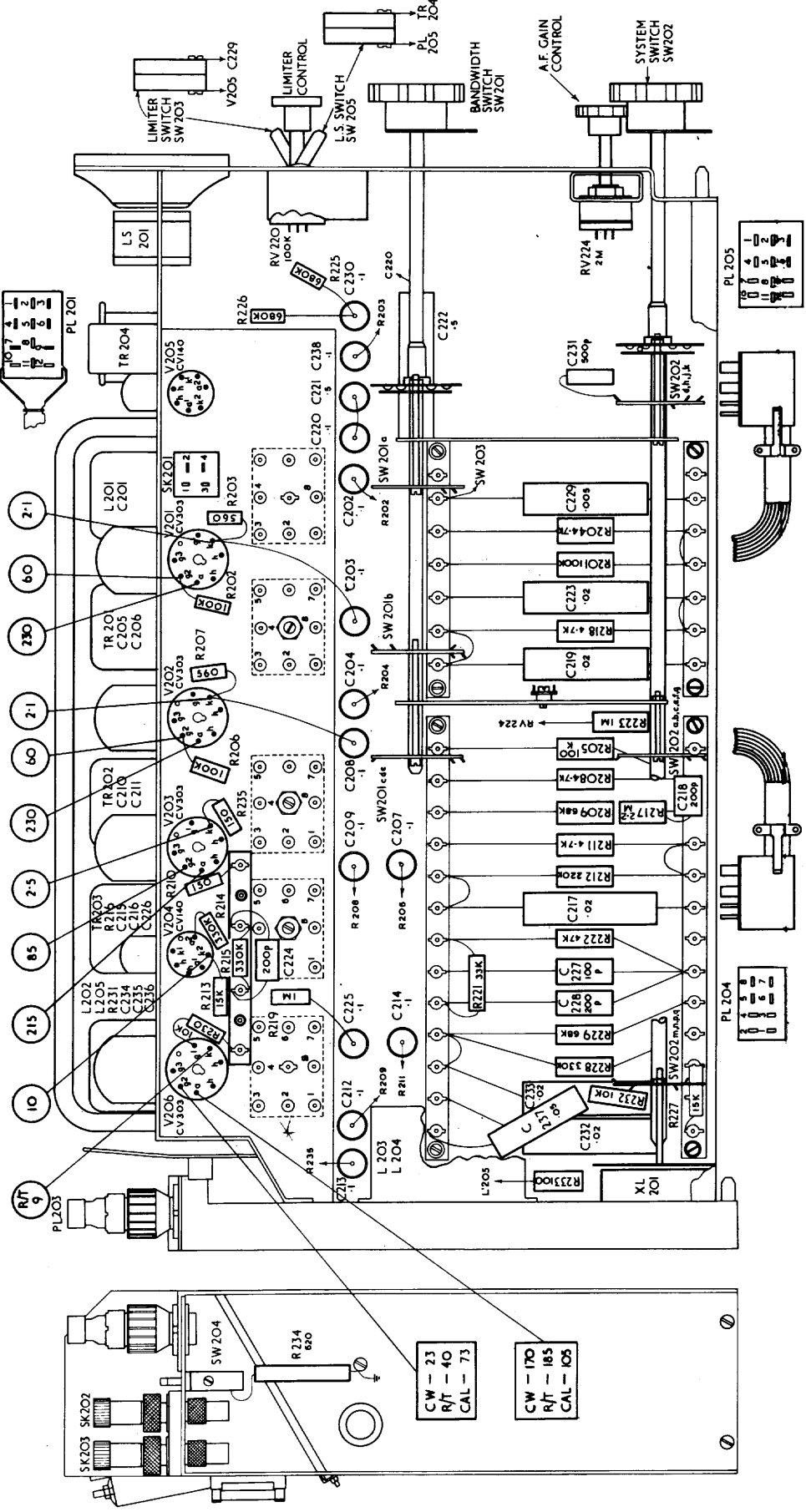

BAND WIDTH SWITCH

BAND WIDTH
SWITCH
SW 201

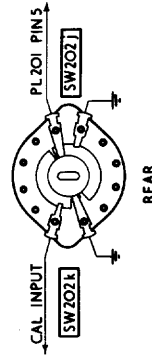
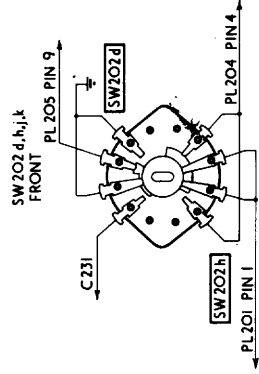
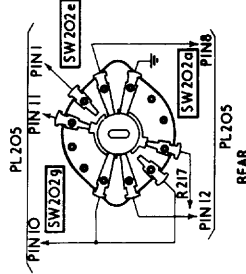
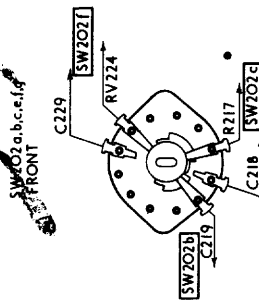
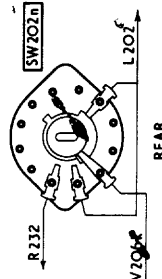
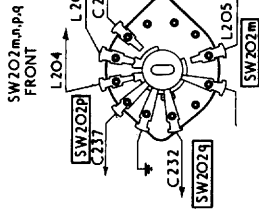
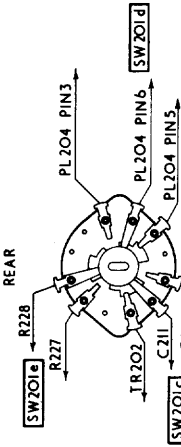
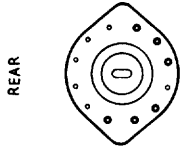
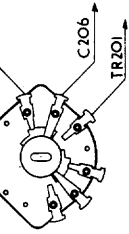
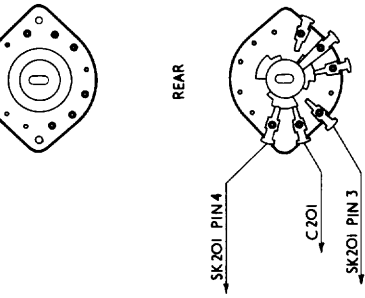

SYSTEM
SWITCH
SW 202

RECEIVER B40. A.P.57140/A.
I.F. UNIT LAYOUT AND SWITCH WIRING DIAGRAM.

R	216	202	204	206	205	208	209	210	217	212	213	216	211	221	223	226	225	R
C	201	203	204	206	207	208	209	212	213	217	216	218	215	219	227	228	230	C
MISC.	PL201	SW201a	TR201	SW201b	V202	SW202a	TR202	SW202b	SW202c	SK202	V204a	TR203	SW203	RV220	SW203f	SW203g	RV224	PL204
	SK201	SW205	TR204	SW204	SW201c	SW204a	XL201	SW204b	L203	SW201e	L202	V206	SW202n	SW202d	SW202e	SW202f	SK203	SK203
	TL	PL203	SW204	SW2029	PL205	L201	SW202k	SW202l	SW202m	L205	SW202p	SW202q	SW202r	SW202s	SW202t	SW202u	SW202v	SW202w

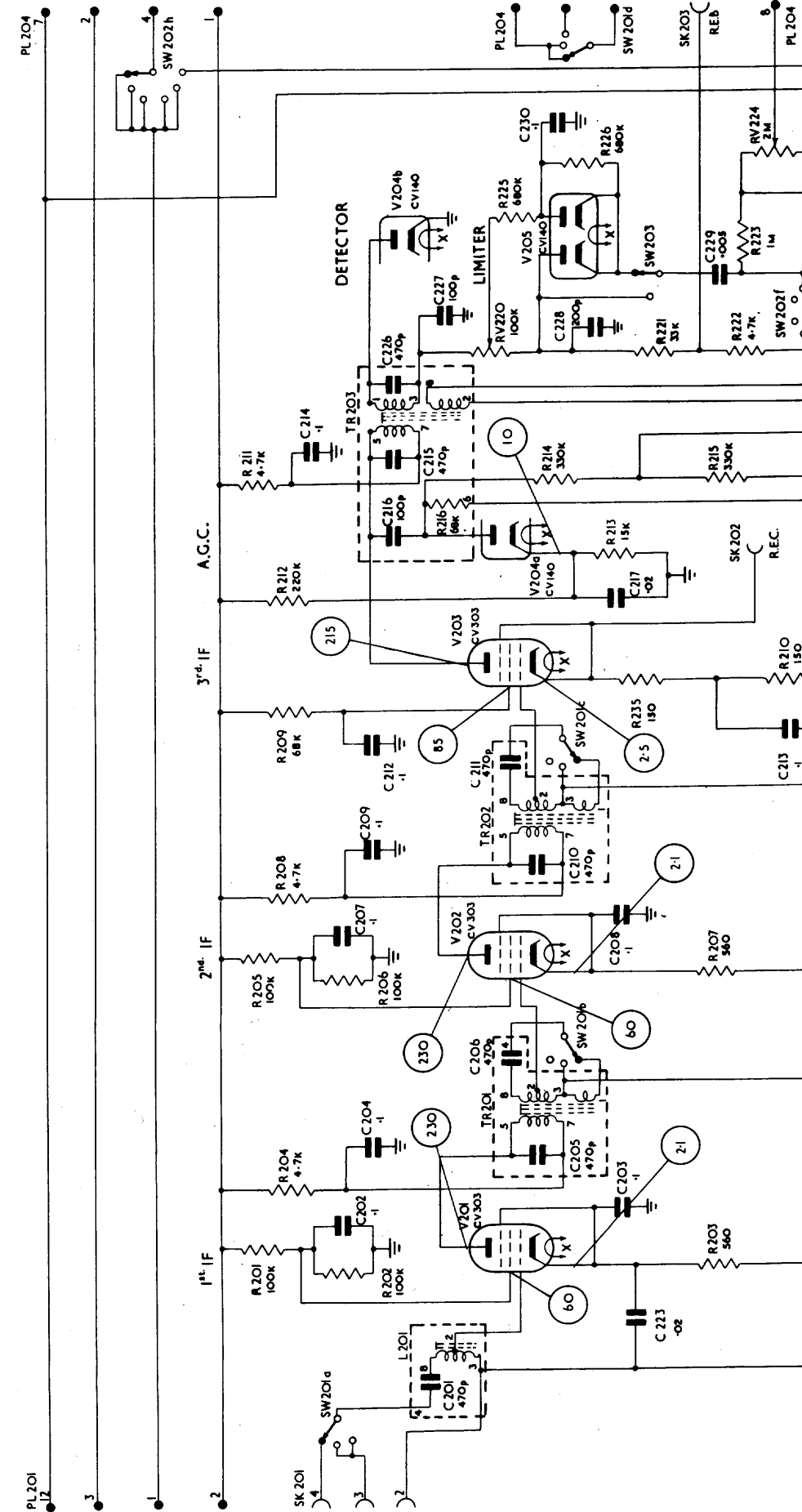

C O M P O N E N T S L I S T B 4 0 R E C E I V E R S

P A T T E R N S 5 7 1 4 0 / A

I . F . U N I T

CAPACITORS

Ref.	A.P. or Joint Service Cat. No.	Value	Tol.	Rating	Remarks
C201	Z125665	470 pF	5%	350V	
C202	Z115095	0.1 μF	20%	350V	
C203	Z115095	0.1 μF	20%	350V	
C204	Z115095	0.1 μF	20%	350V	
C205	Z125665	470 pF	5%	350V	
C206	Z125665	470 pF	5%	350V	
C207	Z115095	0.1 μF	20%	350V	
C208	Z115095	0.1 μF	20%	350V	
C209	Z115095	0.1 μF	20%	350V	
C210	Z125665	470 pF	5%	350V	
C211	Z125665	470 pF	5%	350V	
C212	Z115095	0.1 μF	20%	350V	
C213	Z115095	0.1 μF	20%	350V	
C214	Z115095	0.1 μF	20%	350V	
C215	Z125665	470 pF	5%	350V	
C216	Z123194	100 pF	20%	350V	
C217	Z115504	0.02 μF	20%	750V	
C218	Z123274	200 pF	20%	350V	
C219	Z115504	0.02 μF	20%	750V	
C220	Z115095	0.1 μF	20%	350V	
C221	Z115095	0.1 μF	20%	350V	
C222	Z115148	0.5 μF	20%	350V	
C223	Z115504	0.02 μF	20%	750V	
C224	Z123274	200 pF	20%	350V	
C225	Z115095	0.1 μF	20%	350V	
C226	Z125665	470 pF	5%	350V	
C227	Z123194	100 pF	20%	350V	
C228	Z123274	200 pF	20%	350V	
C229	Z115502	0.005 μF	20%	1000V	
C230	Z115095	0.1 μF	20%	350V	
C231	Z123456	500 pF	20%	350V	
C232	Z115504	0.02 μF	20%	750V	
C233	Z115504	0.02 μF	20%	750V	
C234	Z123194	100 pF	20%	350V	
C235	Z123456	500 pF	20%	350V	

CAPACITORS (Continued)

Ref.	A.P. or Joint Service Cat. No.	Value	Tol.	Rating	Remarks
C236	Z125665	470 pF	5%	350V	
C237	Z115505	0.05 μ F	20%	500V	
C238	Z115095	0.1 μ F	20%	350V	

RESISTORS

Ref.	A.P. or Joint-Service Cat. No.	Value	Tol.	Rating	Remarks
R201	Z223039	100k ohms	10%	$\frac{3}{4}$ W	
R202	Z223038	100k ohms		$\frac{1}{2}$ W	
R203	Z221206	560 ohms		$\frac{1}{2}$ W	
R204	Z222090	4.7k ohms		$\frac{3}{4}$ W	
R205	Z223039	100k ohms		$\frac{3}{4}$ W	
R206	Z223038	100k ohms		$\frac{1}{2}$ W	
R207	Z221206	560 ohms		$\frac{1}{2}$ W	
R208	Z222090	4.7k ohms		$\frac{3}{4}$ W	
R209	Z223018	68k ohms		$\frac{3}{4}$ W	
R210	Z221131	150 ohms		$\frac{1}{2}$ W	
R211	Z222090	4.7k ohms	$\frac{3}{4}$ W	Variable	
R212	Z223081	220k ohms	$\frac{3}{4}$ W		
R213	Z222152	15k ohms	$\frac{1}{2}$ W		
R214	Z223101	330k ohms	$\frac{1}{2}$ W		
R215	Z223101	330k ohms	$\frac{1}{2}$ W		
R216	Z223017	68k ohms	$\frac{1}{2}$ W		
R217	Z223206	2.2M ohms	$\frac{1}{2}$ W		
R218	Z222090	4.7k ohms	$\frac{3}{4}$ W		
R219	Z223164	1 Megohm	$\frac{1}{2}$ W		
RV220	52440A	100k ohms	20%		$\frac{1}{4}$ W
R221	Z222195	33k ohms	10%	$\frac{3}{4}$ W	Variable
R222	Z222090	4.7k ohms		$\frac{3}{4}$ W	
R223	Z223164	1 Megohm		$\frac{1}{2}$ W	
RV224	60254A	2.0M ohms	20%	$\frac{1}{4}$ W	Variable
R225	Z223143	680k ohms	$\frac{1}{2}$ W		
R226	Z223143	680k ohms	10%	$\frac{1}{2}$ W	
R227	Z222153	15k ohms		$\frac{3}{4}$ W	
R228	Z223102	330k ohms		$\frac{3}{4}$ W	
R229	Z223018	68k ohms		$\frac{3}{4}$ W	
R230	Z222131	10k ohms		$\frac{1}{2}$ W	

RESISTORS (Continued)

Ref.	A.P. or Joint Service Cat. No.	Value	Tol.	Rating	Remarks
R231	Z223038	100k ohms	10%	$\frac{1}{2}W$	
R232	Z222132	10k ohms	10%	$\frac{3}{4}W$	
R233	Z221111	100 ohms	10%	$\frac{3}{4}W$	
R234	Z243173	620 ohms	5%	4.5W	
R235	Z221131	150 ohms	10%	$\frac{1}{2}W$	

TRANSFORMERS

Ref.	Pattern	Description
TR201	65690	1st IF Transformer
TR202		2nd IF Transformer
TR203		3rd IF Transformer
TR204		Monitor Loudspeaker Transformer

INDUCTORS

Ref.	Description
L201	Coil, IF Input
L202	Coil Tuned, B.F.O.
L203	Coil Pitch, B.F.O. 'TUNE'
L204	Coil Pitch, B.F.O. 'LOW'
L205	Coil, B.F.O.

LOUDSPEAKER

Ref.	Pattern	Description
LS201	57160 (B40) 972-9307	Monitor Loudspeaker, 3 ohms

PLUGS AND SOCKETS

Ref.	A.P. or Joint Service Cat. No.	Description
FL201	60157	Plug 12 Pin, Inter-connection IF/RF Units
FL203	Z560080	Plug 6 Pin, Outputs (Mk. 4)
FL204	60158	Plug 8 Pin, Inter-connection IF/AF and Power Units
FL205	60157	Plug 12 Pin, Inter-connection IF/AF and Power Units

PLUGS AND SOCKETS (Continued)

Ref.	A.P. or Joint Service Cat. No.	Description
SK201	57772	Socket 4 way, IF Input
SK202	60451	Socket Coaxial, R.E.C.
SK203	60451	Socket Coaxial, R.E.B.

SWITCHES

Ref.	Pattern	Description
SW201		Switch 3 Position, Bandwidth
SW202		Switch 6 Position, System
SW203	W9836A	Switch Single Pole, Limiter
SW204	W9836A	Switch Single Pole, Dummy Load
SW205	W9836A	Switch Single Pole, Monitor Loudspeaker

CRYSTAL

Ref.	Pattern	Description
XL201	A/500	Crystal 500 kc/s, Calibrate

FIG. 14

A.P. 57140 B/C

RECEIVER B40

I.F. UNIT CIRCUIT DIAGRAM.

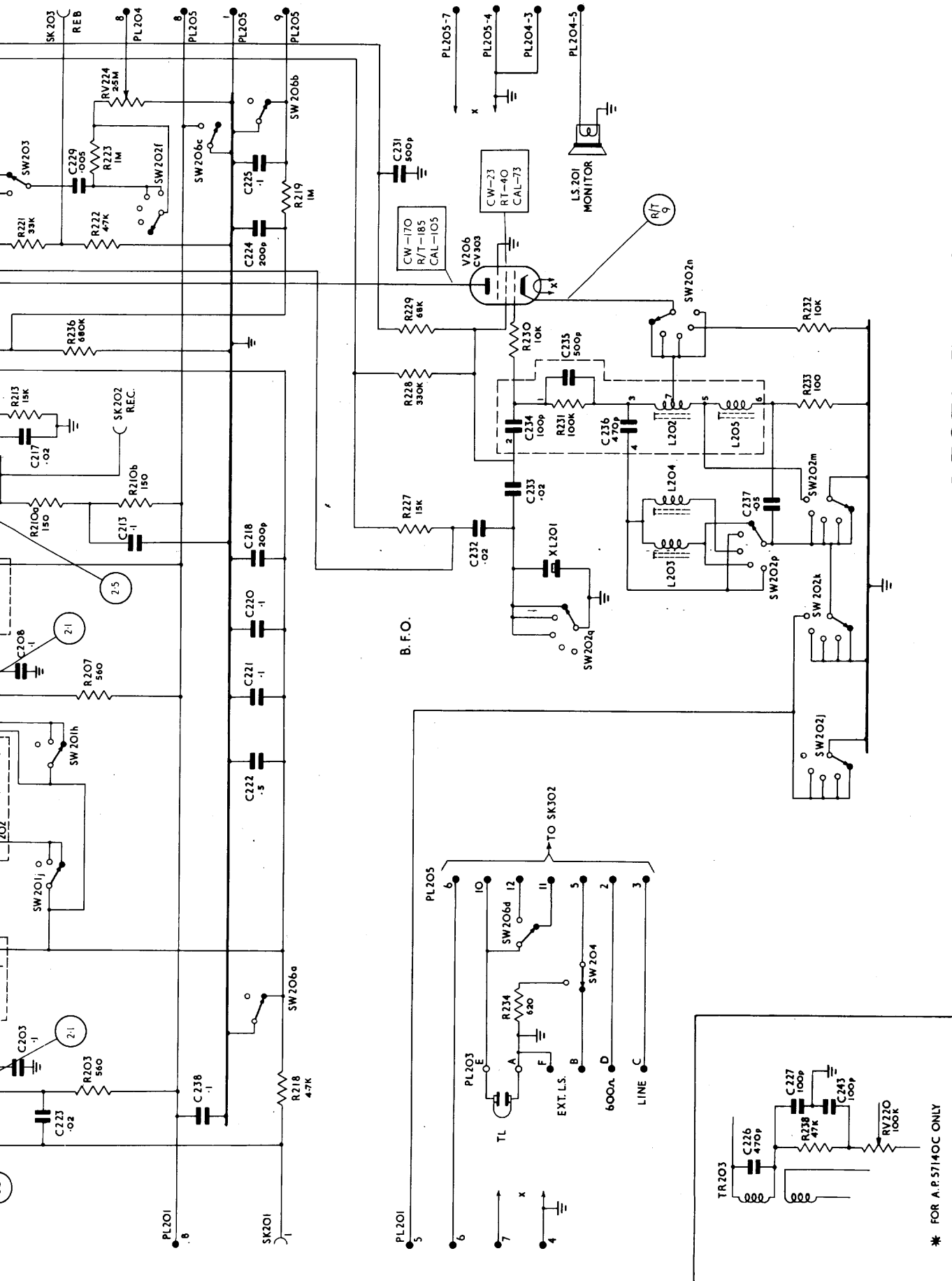

R	202 201 204	209	212 213 215 211 279 221	225 226	225	226	R
C	238 218 203 234	207	227 210a 210b 231	228 236 233 232 222	219 223	226	C
	201 243 202 204 206	207 210 209 212 213 233 217 234 216	215 214 226 227 229 225	230			
	223 238 203 205	221 208 220 211 212 212	235				
MISC	PL201 L201 V201 TR201 SW201a SW201b SW201c XL202 PL203 SW203a SW203b SW203c SW203d SW203e SW203f SW203g SW203h SW203i SW203j SW203k SW203l SW203m SW203n SW203o SW203p SW203q SW203r SW203s SW203t SW203u SW203v SW203w SW203x SW203y SW203z	SW201g SW201h L206 SW201j PL205	V202 TR202 SW202a XL201 L203 L204 L205	TR203 RV220 V205 V204b SW202h PL204 SK201 SK202 SK203 SK204 SK205 SK206 SK207 SK208 SK209 SK210 SK211 SK212 SK213 SK214 SK215 SK216 SK217 SK218 SK219 SK220 SK221 SK222 SK223 SK224 SK225 SK226 SK227 SK228 SK229 SK230 SK231 SK232 SK233 SK234 SK235 SK236 SK237 SK238 SK239 SK240 SK241 SK242 SK243 SK244 SK245 SK246 SK247 SK248 SK249 SK250 SK251 SK252 SK253 SK254 SK255 SK256 SK257 SK258 SK259 SK260 SK261 SK262 SK263 SK264 SK265 SK266 SK267 SK268 SK269 SK270 SK271 SK272 SK273 SK274 SK275 SK276 SK277 SK278 SK279 SK280 SK281 SK282 SK283 SK284 SK285 SK286 SK287 SK288 SK289 SK290 SK291 SK292 SK293 SK294 SK295 SK296 SK297 SK298 SK299 SK300			MISC

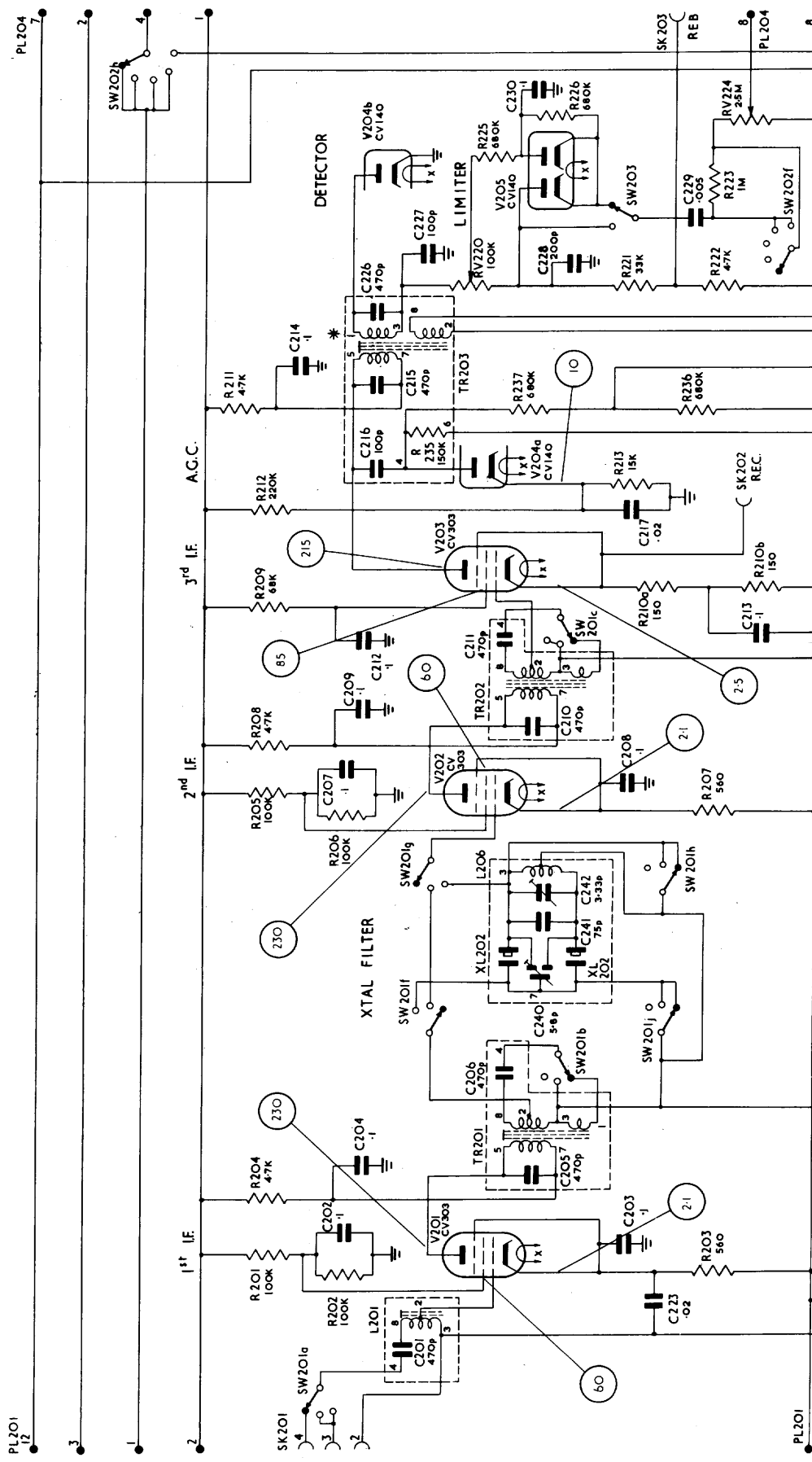

COMPONENT LIST, RECEIVER B40,

PATTERNS 57140B/C

I F UNIT

CAPACITORS

Ref.	A.P. or Joint Service Cat. No.	Value	Tol.	Rating	Remarks
C201	Z125665	470 pF	5%	350V	
C202	Z115506	0.1 μ F	20%	350V	
C203	Z115095	0.1 μ F	20%	350V	
C204	Z115095	0.1 μ F	20%	350V	
C205	Z125665	470 pF	5%	350V	
C206	Z125665	470 pF	5%	350V	
C207	Z115095	0.1 μ F	20%	350V	
C208	Z115095	0.1 μ F	20%	350V	
C209	Z115095	0.1 μ F	20%	350V	
C210	Z125665	470 pF	5%	350V	
C211	Z125665	470 pF	5%	350V	
C212	Z115095	0.1 μ F	20%	350V	
C213	Z115095	0.1 μ F	20%	350V	
C214	Z115095	0.1 μ F	20%	350V	
C215	Z125665	470 pF	5%	350V	
C216	Z123194	100 pF	20%	350V	
C217	Z115504	0.02 μ F	20%	750V	
C218	Z123274	200 pF	20%	350V	
C220	Z115095	0.1 μ F	20%	350V	
C221	Z115095	0.1 μ F	20%	350V	
C222	Z115148	0.5 μ F	20%	350V	
C223	Z115504	0.02 μ F	20%	750V	
C224	Z123274	200 pF	20%	350V	
C225	Z115095	0.1 μ F	20%	350V	
C226	Z125665	470 pF	5%	350V	
C227	Z123194	100 pF	20%	350V	
C228	Z123274	200 pF	20%	350V	
C229	Z115502	0.005 μ F	20%	1000V	
C230	Z115095	0.1 μ F	20%	350V	
C231	Z123456	500 pF	20%	350V	
C232	Z115504	0.02 μ F	20%	750V	
C233	Z115504	0.02 μ F	20%	750V	
C234	Z123194	100 pF	20%	350V	
C235	Z123456	500 pF	20%	350V	
C236	Z125665	470 pF	5%	350V	

CAPACITORS (Continued)

Ref.	A.P. or Joint Service Cat. No.	Value	Tol.	Rating	Remarks
C237	Z115505	0.05 μ F	20%	500V	Variable
C238	Z115095	0.1 μ F	20%	350V	
C240		5-8 pF			
C241	Z125199	75 pF	2%	350V	Variable B40C only
C242	972-6179	4-34 pF			
C243	Z123194	100 pF	20%	350V	

RESISTORS

Ref.	A.P. or Joint Service Cat. No.	Value	Tol.	Rating	Remarks	
R201	Z223039	100k ohms	10%	$\frac{1}{2}$ W		
R202	Z223038	100k ohms		$\frac{1}{2}$ W		
R203	Z221206	560 ohms		$\frac{1}{2}$ W		
R204	Z222090	4.7k ohms		$\frac{1}{2}$ W		
R205	Z223039	100k ohms		$\frac{1}{2}$ W		
R206	Z223038	100k ohms		1W		
R207	Z221206	560 ohms		$\frac{1}{2}$ W		
R208	Z222090	4.7k ohms		$\frac{1}{2}$ W		
R209	Z223018	68k ohms		$\frac{1}{2}$ W		
R210A/B	Z221131	150 ohms		$\frac{1}{2}$ W		
R211	Z222090	4.7k ohms		$\frac{1}{2}$ W		
R212	Z223081	220k ohms		$\frac{1}{2}$ W		
R213	Z222152	15k ohms		$\frac{1}{2}$ W		
R218	Z222090	4.7k ohms		$\frac{1}{2}$ W		
R219	Z223164	1 Megohm		$\frac{1}{2}$ W		
RV220	Z262183	100k ohms		$\frac{1}{2}$ W		Variable
R221	Z222195	33k ohms		$\frac{1}{2}$ W		Variable
R222	Z222090	4.7k ohms		$\frac{1}{2}$ W		
R223	Z223164	1 Megohm		$\frac{1}{2}$ W		
RV224	Z262948	2.5M ohms		1W		
R225	Z223143	680k ohms		$\frac{1}{2}$ W		
R226	Z223143	680k ohms		$\frac{1}{2}$ W		
R227	Z222153	15k ohms		$\frac{1}{2}$ W		
R228	Z223102	330k ohms		$\frac{1}{2}$ W		
R229	Z223018	68k ohms		$\frac{1}{2}$ W		
R230	Z222131	10k ohms	$\frac{1}{2}$ W			
R231	Z223038	100k ohms	$\frac{1}{2}$ W			
R232	Z222132	10k ohms	$\frac{1}{2}$ W			
R233	Z221111	100 ohms	$\frac{1}{2}$ W			
R234	Z243173	620 ohms	4.5W			
R235	Z223059	150k ohms	$\frac{1}{2}$ W			
R236	Z223143	680k ohms	$\frac{1}{2}$ W			
R237	Z223143	680k ohms	$\frac{1}{2}$ W			

TRANSFORMERS

Ref.	Pattern No.	Description
TR201 to TR203 TR204 TR205	65690	Transformers IF Transformer AF Transformer AF (S.R.E. Output, Receiver 62B only)

INDUCTORS

Ref.	Description
L201	Coil IF, -IF Input-
L202	Coil tuned - B.F.O.
L203	Coil Pitch - B.F.O. "TUNE"
L204	Coil Pitch - B.F.O. "LOW"
L205	Coil, - Calibration Coupling -
L206	Coil tuned - Crystal Filter -

LOUDSPEAKER

Ref.	Pattern	Description
LS201	972-9307	Loudspeaker, 3 ohms, Monitor

PLUGS AND SOCKETS

Ref.	A.P. or Joint Service Cat. No.	Description
PL201	60157	Plug 12 Pin, Inter-connecting IF/RF Units
PL203	Z560080	Plug 6 Pin, Outputs (Mk. 4)
PL204	60158	Plug 8 Pin, Inter-connecting IF/AF and Power Units
PL205	60157	Plug 12 Pin, Inter-connecting IF/AF and Power Units
SK201	57772	Socket 4 way, IF Input
SK202	60451	Socket Single, R.E.C.
SK203	60451	Socket Single, R.E.B.

SWITCHES

Ref.	A.P. or Joint Service Cat. No.	Description
SW201	5930-99-972-8826 W9836A	Switch, 3 position - Bandwidth
SW202		Switch, 5 position - System
SW203		Switch, single pole - Limiter
SW204		Switch, single pole - Dummy Load
SW206	5930-99-972-8825	Switch, two position - A.G.C.

CRYSTALS

Ref.	Pattern No.	Description
XL201 XL202 -	67864	Crystal, 500 kc/s, Calibrate Crystal, Crystal Filter Crystal, Filter Unit

SWITCH WAFERS

Ref.	Pattern No.
SW202 m, n, p, q	65636
SW202 f	65635
SW202 h, j, k	65634
SW201 c	65633
SW201 b	65632
SW201 a	65631
SW201 f, g, h, j	not patternised (A.S.W.E. Drawing 57240)

VOLTAGES TAKEN
WITH AVOMETER
MODEL 8 A.P. 12945

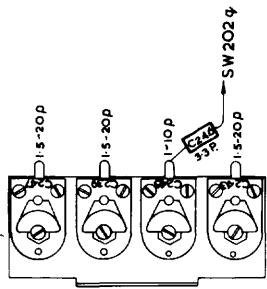

**BAND WIDTH
SWITCH
SW 201.**

WAFERS NUMBERED FROM FRONT PANEL END
FRONT AND REAR CONTACTS WIRED TOGETHER
WHERE MARKED *

**SYSTEM
SWITCH
SW 202.**

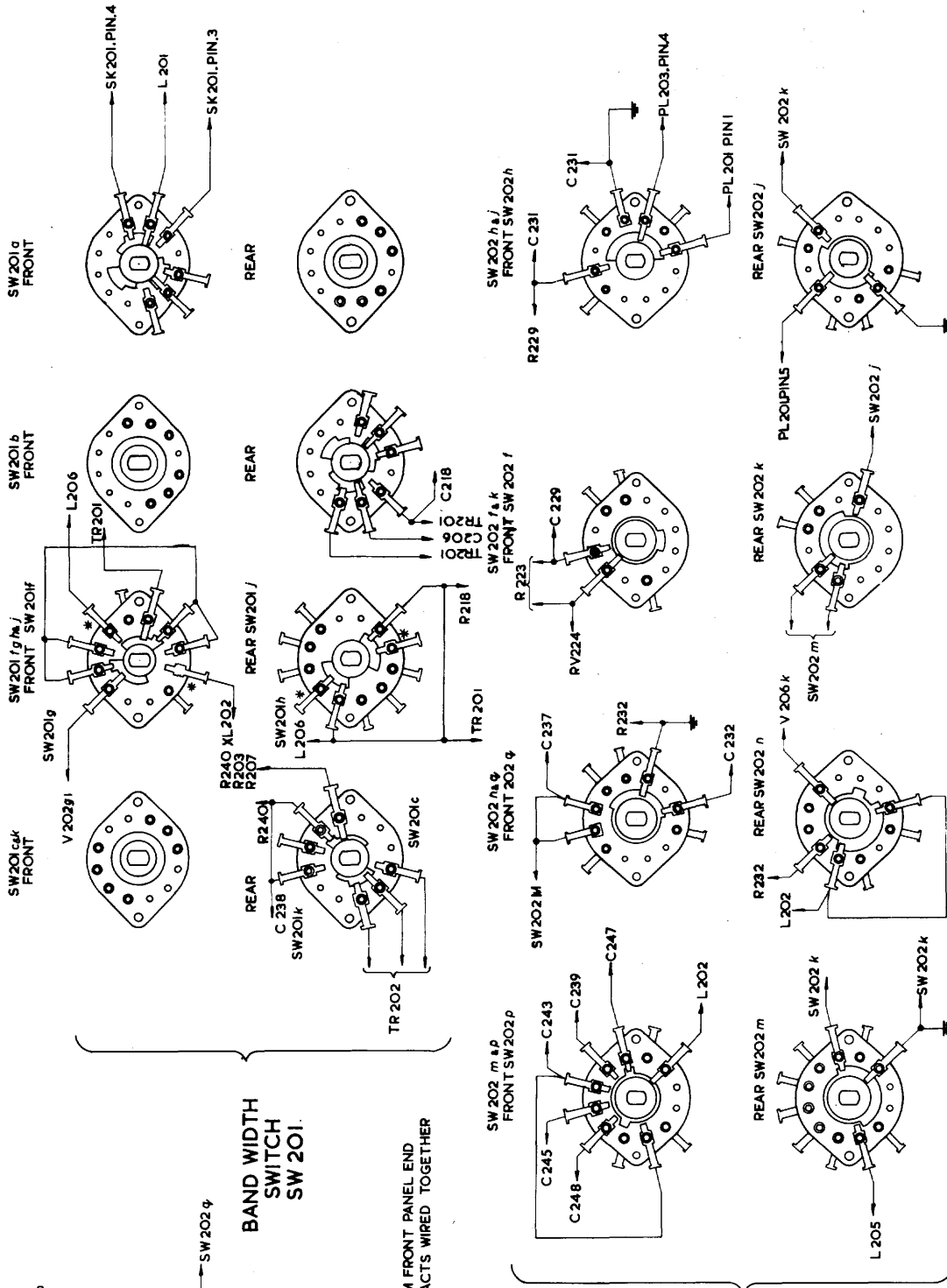

RECEIVER B40 A P 57140 D
I.F. UNIT. LAYOUT AND SWITCH WIRING DIAGRAM.

FIG. 16

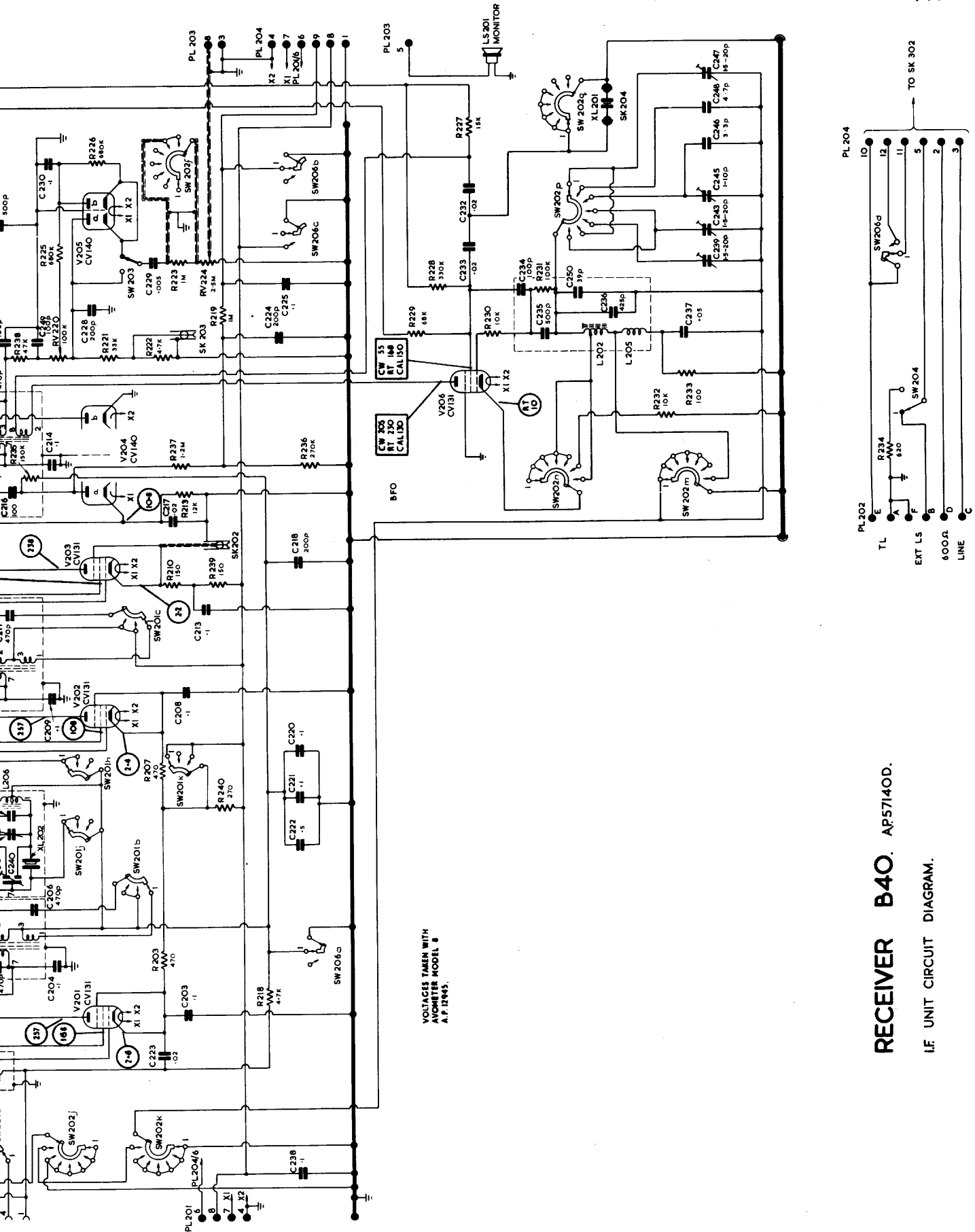

RECEIVER B40. AP:57140D.

I.F. UNIT CIRCUIT DIAGRAM.

C	238	201	202	203	205	206	240	242	241	222	221	220	207	209	210	211	218	217	216	214	215	226	227	236	225	229	231	245	230	246	247	C	
R		201	202	203	204	203	240	207	208	208	208	208	208	208	208	208	208	210	210	210	210	210	226	226	226	226	226	226	226	226	226	226	R
MISC.	PL201 SK201	SW201g SW201j SW201k	L201	V201	TR201 SW201a	SW201f SW201h SW201i SW201j SW201k	XL202 L206 SW201h SW201i SW201j	SW201g SW201h SW201i SW201j	SW201g SW201h SW201i SW201j	SW201g SW201h SW201i SW201j	SW201g SW201h SW201i SW201j	SW201g SW201h SW201i SW201j	SW201g SW201h SW201i SW201j	SW201g SW201h SW201i SW201j	SW201g SW201h SW201i SW201j	SW201g SW201h SW201i SW201j	SW201g SW201h SW201i SW201j	SW201g SW201h SW201i SW201j	SW201g SW201h SW201i SW201j	SW201g SW201h SW201i SW201j	SW201g SW201h SW201i SW201j	SW201g SW201h SW201i SW201j	SW201g SW201h SW201i SW201j	SW201g SW201h SW201i SW201j	SW201g SW201h SW201i SW201j	SW201g SW201h SW201i SW201j	SW201g SW201h SW201i SW201j	SW201g SW201h SW201i SW201j	SW201g SW201h SW201i SW201j	SW201g SW201h SW201i SW201j	SW201g SW201h SW201i SW201j	MISC.	

IF UNIT

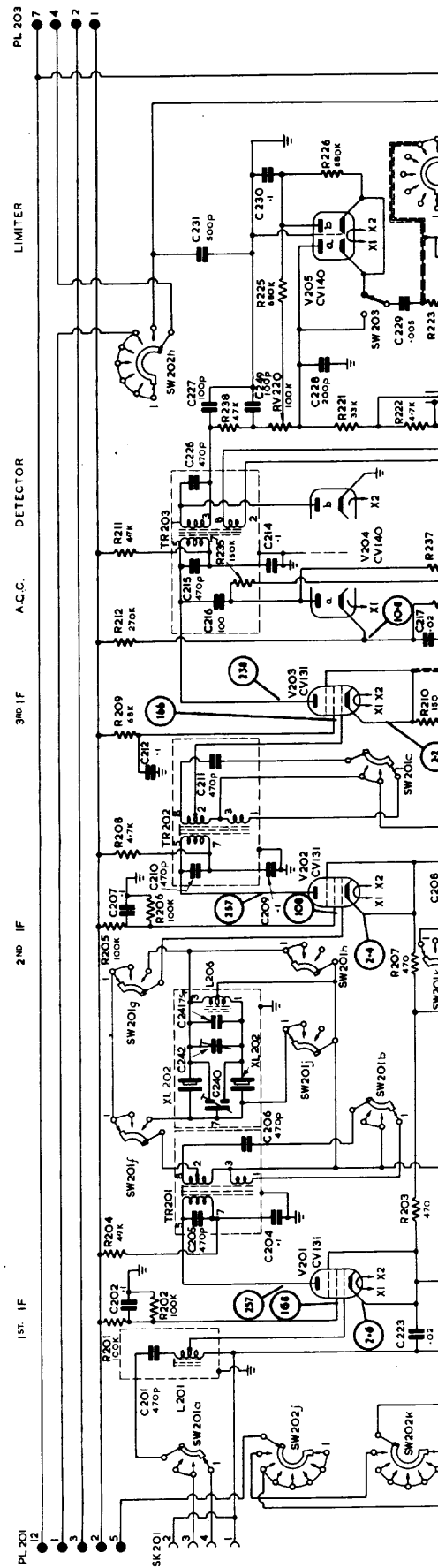

COMPONENTS LIST, RECEIVER B40

PATTERN 57140D

IF UNIT

CAPACITORS

Ref.	A. P. or Joint-Service Cat. No.	Value	Tol.	Rating	Remarks
C201	012-3984	470 pF	5%	750V	
C202	011-7818	0.1 μ F	20%	350V	
C203	011-5095	0.1 μ F	20%	350V	Stud mounting
C204	011-5095	0.1 μ F	20%	350V	Stud mounting
C205	012-3984	470 pF	5%	750V	
C206	012-3984	470 pF	5%	750V	
C207	011-5095	0.1 μ F	20%	350V	Stud mounting
C208	011-5095	0.1 μ F	20%	350V	Stud mounting
C209	011-5095	0.1 μ F	20%	350V	Stud mounting
C210	012-3984	470 pF	5%	750V	
C211	012-3984	470 pF	5%	750V	
C212	011-5095	0.1 μ F	20%	350V	Stud mounting
C213	011-5095	0.1 μ F	20%	350V	Stud mounting
C214	011-5095	0.1 μ F	20%	350V	Stud mounting
C215	012-3984	470 pF	5%	750V	
C216	012-3165	100 pF	20%	750V	
C217	011-7826	0.02 μ F	20%	750V	
C218	012-3292	200 pF	10%	750V	
C219					No Capacitor
C220	011-5095	0.1 μ F	20%	350V	
C221	011-5095	0.1 μ F	20%	350V	Stud mounting
C222	011-5148	0.5 μ F	20%	350V	
C223	011-7826	0.02 μ F	20%	750V	
C224	012-3292	200 pF	10%	750V	
C225	011-5095	0.1 μ F	20%	350V	Stud mounting
C226	012-3984	470 pF	5%	750V	
C227	012-3165	100 pF	20%	750V	
C228	012-3292	200 pF	10%	750V	
C229	011-7827	0.005 μ F	20%	1000V	
C230	011-5095	0.1 μ F	20%	350V	Stud mounting
C231	012-3412	500 pF	10%	750V	
C232	011-7826	0.02 μ F	20%	750V	
C233	011-7826	0.02 μ F	20%	750V	
C234	012-3165	100 pF	20%	750V	
C235	012-3412	500 pF	10%	750V	

CAPACITORS (Cont'd.)

Ref.	A.P. or Joint-Service Cat. No.	Value	Tol.	Rating	Remarks
C236		425 pF	5%	350V	Lemco 1510
C237	011-7822	0.05 μ F	20%	500V	
C238	011-5095	0.1 μ F	20%	350V	
C239	016-0009	4-18 pF	10%		Variable
C240	945-4604	1.5-8 pF			Variable - Oxley Diff. D.V.C. 1-5/8
C241	972-2071	75 pF	2%	350V	Lemco 1510
C242	016-0047	3-30 pF			Variable, W & R C30-01
C243	016-0009	4-18 pF	10%		Variable
C244		2-12 pF			Variable, W & R C31/11A
C245	972-6178				
C246	012-6768	3.3 pF	0.5 pF	750V	
C247	016-0009	4-18 pF	10%		Variable
C248	012-6770	4.7 pF	0.5 pF	750V	
C249	012-3165	100 pF	20%	750V	
C250	012-7103	39 pF	5%	750V	

RESISTORS

Ref.	A.P. or Joint-Service Cat. No.	Value	Tol.	Rating	Remarks
R201	022-3039	100k ohms	10%	$\frac{3}{4}$ W	
R202	022-3037	100k ohms	10%	$\frac{1}{2}$ W	
R203	022-1193	470 ohms	10%	$\frac{1}{2}$ W	
R204	022-2090	4.7k ohms	10%	$\frac{3}{4}$ W	
R205	022-3039	100k ohms	10%	$\frac{3}{4}$ W	
R206	022-3037	100k ohms	10%	$\frac{1}{2}$ W	
R207	022-1193	470 ohms	10%	$\frac{1}{2}$ W	
R208	022-2090	4.7k ohms	10%	$\frac{3}{4}$ W	
R209	022-3018	68k ohms	10%	$\frac{3}{4}$ W	
R210	022-1130	150 ohms	10%	$\frac{1}{2}$ W	
R211	022-2090	4.7k ohms	10%	$\frac{3}{4}$ W	
R212	022-3093	270k ohms	10%	$\frac{3}{4}$ W	
R213	022-2142	12k ohms	10%	$\frac{1}{2}$ W	
R218	022-2090	4.7k ohms	10%	$\frac{3}{4}$ W	
R219	022-3164	1M ohm	10%	$\frac{1}{2}$ W	
R221	022-2195	33k ohms	10%	$\frac{3}{4}$ W	
R222	022-2090	4.7k ohms	10%	$\frac{3}{4}$ W	
R223	022-3164	1M ohm	10%	$\frac{1}{2}$ W	
R225	022-3143	680k ohms	10%	$\frac{1}{2}$ W	
R226	022-3143	680k ohms	10%	$\frac{1}{2}$ W	

RESISTORS (Cont'd.)

Ref.	A.P. or Joint-Service Cat. No.	Value	Tol.	Rating	Remarks
R227	022-2153	15k ohms	10%	$\frac{3}{4}$ W	Wirewound
R228	022-3102	330k ohms	10%	$\frac{3}{4}$ W	
R229	022-3018	68k ohms	10%	$\frac{3}{4}$ W	
R230	022-2130	10k ohms	10%	$\frac{1}{2}$ W	
R231	022-3037	100k ohms	10%	$\frac{1}{2}$ W	
R232	022-2132	10k ohms	10%	$\frac{3}{4}$ W	
R233	022-1111	100 ohms	10%	$\frac{3}{4}$ W	
R234	011-3482	620 ohms	5%	$4\frac{1}{2}$ W	
R235	022-3058	150k ohms	10%	$\frac{1}{2}$ W	
R236	022-3091	270k ohms	10%	$\frac{1}{2}$ W	
R237	022-3176	1.2M ohms	10%	$\frac{1}{2}$ W	
R238	022-2214	47k ohms	10%	$\frac{1}{2}$ W	
R239	022-1130	150 ohms	10%	$\frac{1}{2}$ W	
R240	022-1163	270 ohms	10%	$\frac{1}{2}$ W	

VARIABLE RESISTORS

Ref.	A.P. or Joint-Service Cat. No.	Value	Tol.	Rating	Remarks
RV220	972-9484	100k ohms	20%	0.1W	Limiter
RV224	972-9485	2.5M ohms	20%	0.1W	A.F. Gain

TRANSFORMERS

Ref.	A.P. or Joint-Service Cat. No.	Description
TR201	A.P.106119	I.F. Transformer
TR203	A.P.106120	I.F. Transformer

INDUCTORS

Ref.	A.P. or Joint-Service Cat. No.	Description
L201	A.P.106118	Coil Tuned, I.F.
L202	A.P.106121	Coil Tuned, B.F.O.
L205	A.P.106121	Coil B.F.O.
L206	A.P.106124	Coil, Crystal Filter

LOUDSPEAKER

Ref.	A.P. or Joint-Service Cat. No.	Description
LS201	972-9307	Loudspeaker, 3 ohms - Monitor

PLUGS AND SOCKETS

Ref.	A.P. or Joint-Service Cat. No.	Description
PL201	972-8214	Plug 12 Pin, Interconnecting (RF/IF Unit)
PL202	972-9112	Plug 6 Pin, Mark 4, Audio Frequency Output
PL203	911-6428) two 972-8208) items	Plug 8 Pin, Interconnection (IF/AF and Power Unit)
PL204	972-8210) two 972-8185) items	Plug 12 Pin, Interconnecting (IF/AF and Power Unit)
SK201	972-8230	Socket, 4 Pin - Interconnecting (RF/IF Units)
SK202	580-3620	Socket, Coaxial - R.E.C.
SK203	580-3620	Socket, Coaxial - R.E.B.
SK204		Socket for B.F.O. Crystal

SWITCHES

Ref.	A.P. or Joint-Service Cat. No.	Description
SW201	A.P.206828	Switch, 3 position, Bandwidth
SW202	A.P.206830	Switch, 7 position, System
SW203	972-8826	Switch, 2 position, Limiter
SW204	A.P.43699	Switch, 2 position, Dummy Load
SW206	972-8825	Switch, 2 position, A.G.C.

CRYSTALS

Ref.	A.P. or Joint-Service Cat. No.	Description
XL201	A.P.67864	Crystal, 500 kc/s - Calibrate
XL202	A517389	Crystal, 500 kc/s - Crystal Filter Crystal Filter Unit

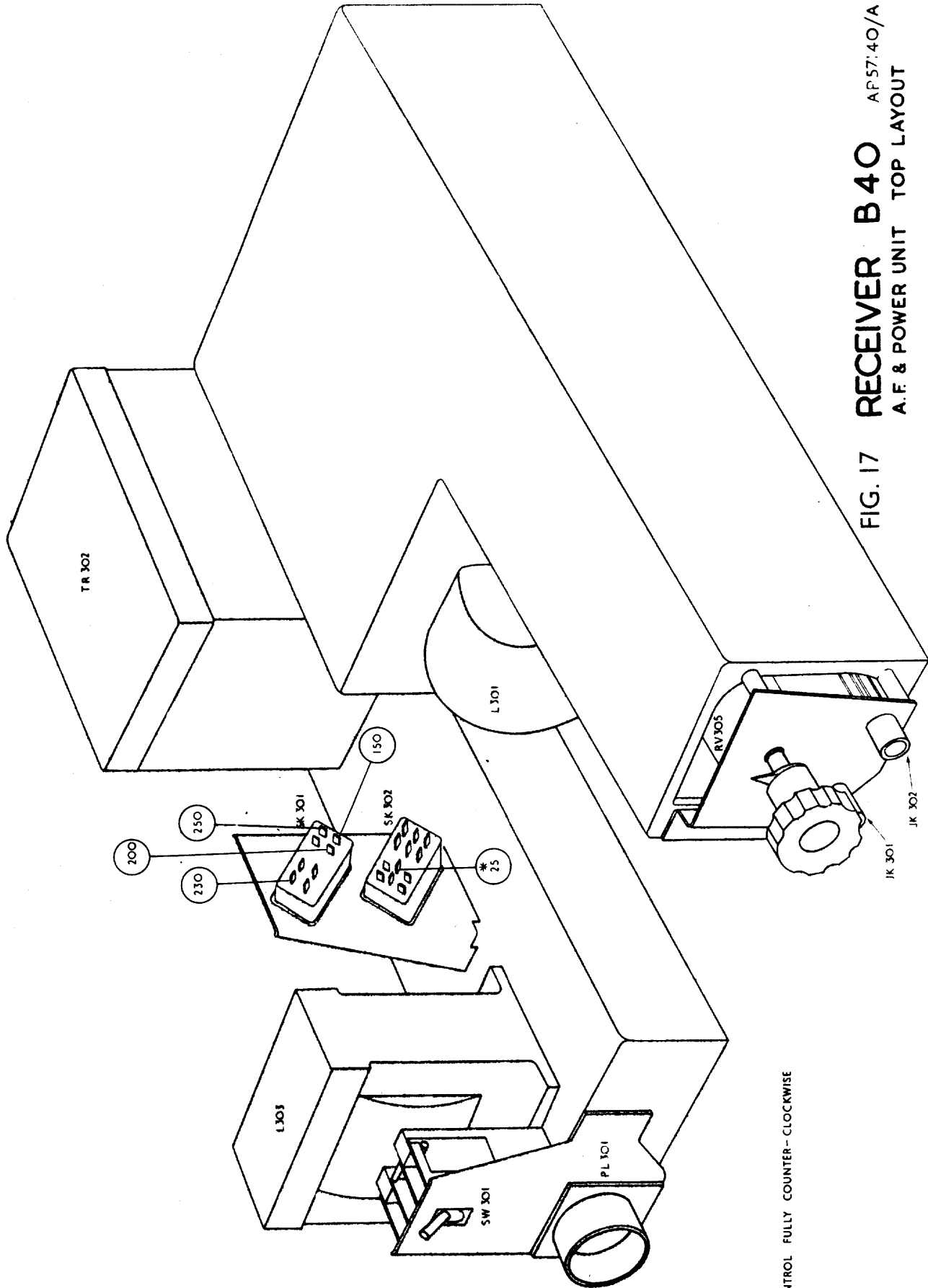

FIG. 17 RECEIVER B40 AF5740/A
A.F. & POWER UNIT TOP LAYOUT

* CONTROL FULLY COUNTER-CLOCKWISE

R	301	303	312	304	307	308	313	310	311		R				
C	309	310	301	306	302	305	303	304	315	307	312	C			
MISC	RV 309	AV 305	JK 302	JK 301	V 301	L 301	V 302	V 303	TR 301	TR 302	L 302	F 302	V 302	F 301	MISC

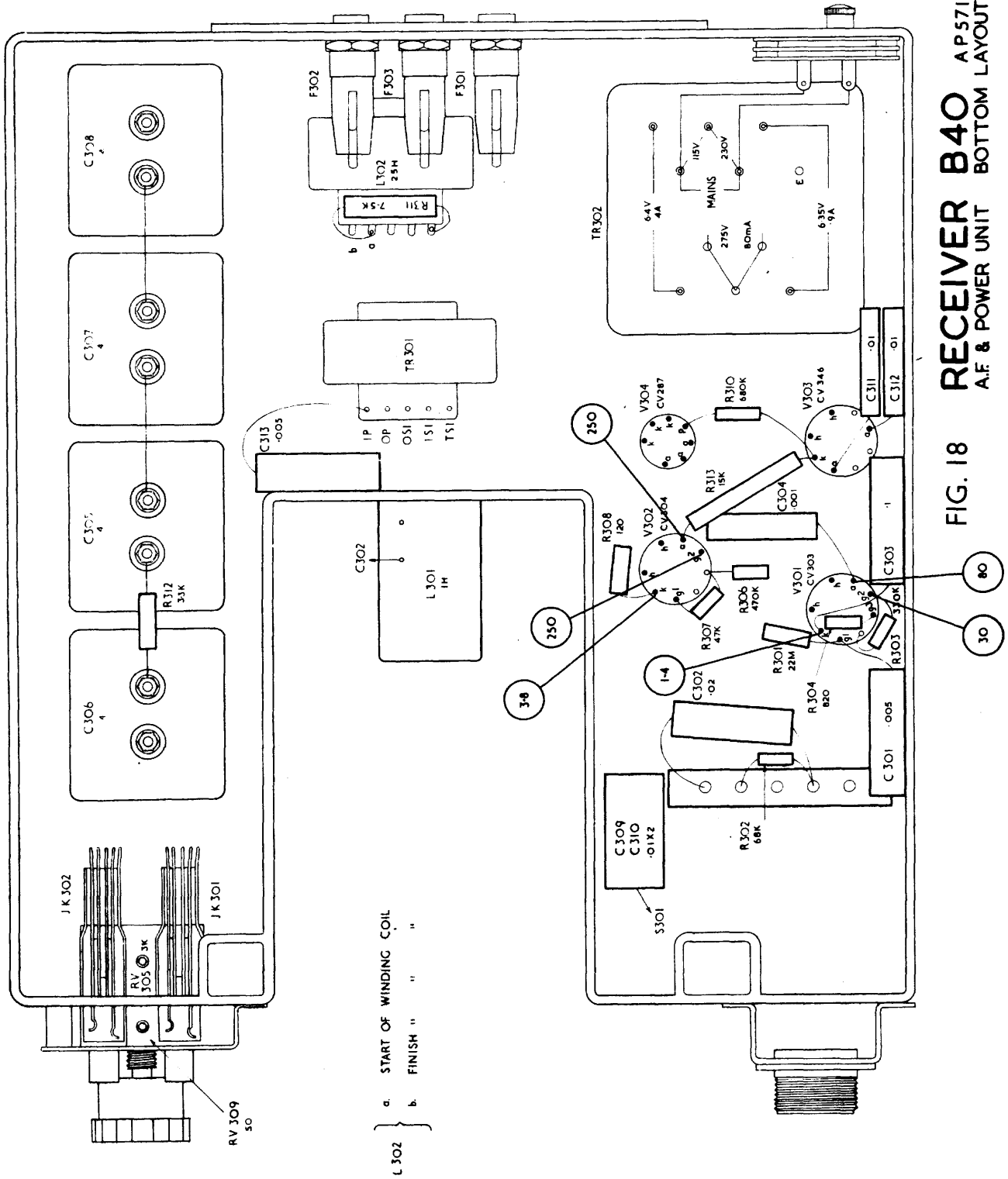
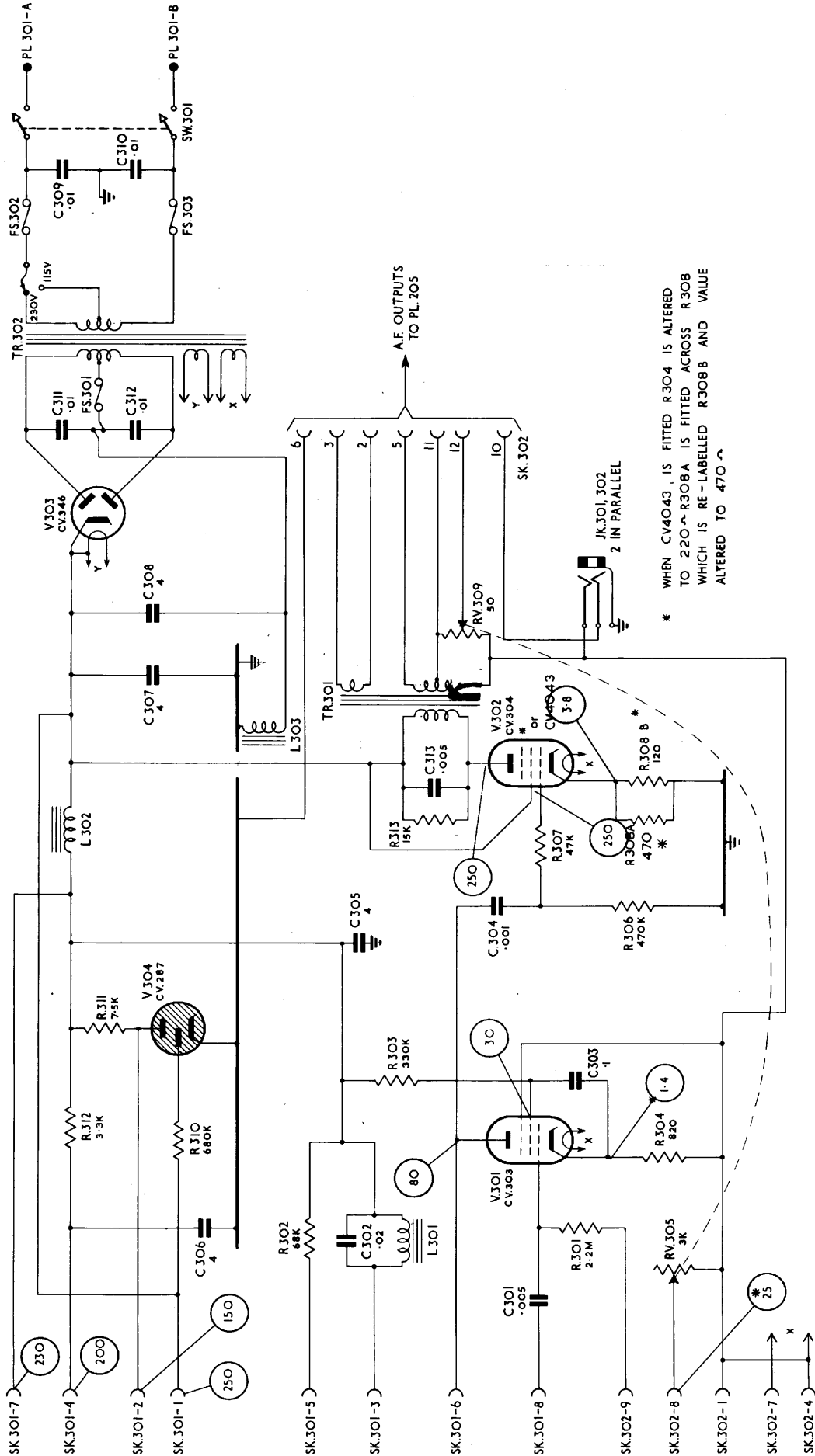

FIG. 18 RECEIVER B40 AP57140/A.
A.F. & POWER UNIT BOTTOM LAYOUT

FIG. 19

R	301.302.	304.312.310.	303.	311.	306.	307.313.	308.	311.312.	309.310.	R
C	301.306.302.	303.	303.	304.	305.304.	307.	308.	302.	303.302.	C
MISC	SK.301.	L.301.	V.301.	V.304.	L.302.	L.303.	TR.301.	SK.302.	FS.302.	SK.301.
	SK.302.	RV.305.			V.302.	V.303.	JK.301.	JK.302.	FS.303.	PL.301.
										MISC



* WHEN CV4043 IS FITTED R304 IS ALTERED TO 220Ω R308A IS FITTED ACROSS R308 WHICH IS RE-LABELLED R308B AND VALUE ALTERED TO 470Ω

RECEIVER B 40 AP 57140/A
A.F. & POWER UNIT - CIRCUIT DIAGRAM

* CONTROL FULLY COUNTER - CLOCKWISE

COMPONENTS LIST RECEIVER B40,

PATTERNS 57140/A

A. F. AND POWER UNIT

CAPACITORS

Ref.	A.P. or Joint Service Cat. No.	Value	Tol.	Rating	Remarks
C301	52162	0.005 μ F	20%	1000V	
C302	Z115516	0.02 μ F	10%	750V	
C303	Z115506	0.1 μ F	20%	350V	
C304	Z115500	0.001 μ F	20%	1000V	
C305	Z112521	4 μ F	20%	400V	
C306	Z112521	4 μ F	20%	400V	
C307	Z112521	4 μ F	20%	400V	
C308	Z112521	4 μ F	20%	400V	
C309	Z124409	0.01 μ F	20%	750V	
C310	Z124409	0.01 μ F	20%	750V	
C311	Z124409	0.01 μ F	20%	750V	
C312	Z124409	0.01 μ F	20%	750V	
C313	Z115502	0.005 μ F	20%	1000V	

RESISTORS

Ref.	A.P. or Joint Service Cat. No.	Value	Tol.	Rating	Remarks
R301	Z223207	2.2M ohms	10%	$\frac{3}{4}$ W	Variable
R302	Z223017	68k ohms		$\frac{1}{2}$ W	
R303	Z223101	330k ohms		$\frac{1}{2}$ W	
R304	Z221227	820 ohms		$\frac{1}{2}$ W	
RV305	Z273001	3k ohms			
R306	Z223122	470k ohms		$\frac{1}{2}$ W	Variable
R307	Z222215	47k ohms		$\frac{1}{2}$ W	
R308	Z221125	120 ohms		$\frac{3}{4}$ W	
RV309	Z273001	50 ohms			
R310	Z223144	680k ohms		$\frac{3}{4}$ W	
R311	Z244085	7.5k ohms	5%	4.5W	} Alternatives to R304 and R308 when CV4043 is fitted.
R312	Z222069	3.3k ohms		$\frac{3}{4}$ W	
R313	Z244114	15k ohms		6W	
R304	022-1148	220 ohms	5%	$\frac{1}{2}$ W	
R308A	022-1192	470 ohms		$\frac{1}{2}$ W	
R308B	022-1192	470 ohms		$\frac{1}{2}$ W	

TRANSFORMERS

Ref.	Pattern	Description
TR301	65689	Output Transformer
TR302	65561B	Mains Transformer

INDUCTORS

Ref.	Pattern	Description
L301		Choke 1H, Note Filter
L302	65560	Choke 18H, Smoothing
L303	65564	Choke 10H, Smoothing

FUSES

Ref.	Pattern	Description
F301	Z590108	Fuse 0.5 Amp
F302	Z590110	Fuse 2 Amp
F303	Z590110	Fuse 2 Amp

PLUGS AND SOCKETS

Ref.	A.P. or Joint Service Cat. No.	Description
PL301	Z560050	Plug 2 Pin, Mains (Mark 4)
SK301	W8369	Socket 8 Way, IE/AF and Power Unit
SK302	60156	Socket 12 Way, IE/AF and Power Unit

SWITCHES

Ref.	Pattern	Description
SW301	60448	Switch, Double Pole, Mains

JACKS

Ref.	Pattern	Description
JK301/2	676A	Jacks, 3 Pole, Telephones

FIGS. 20 & 21

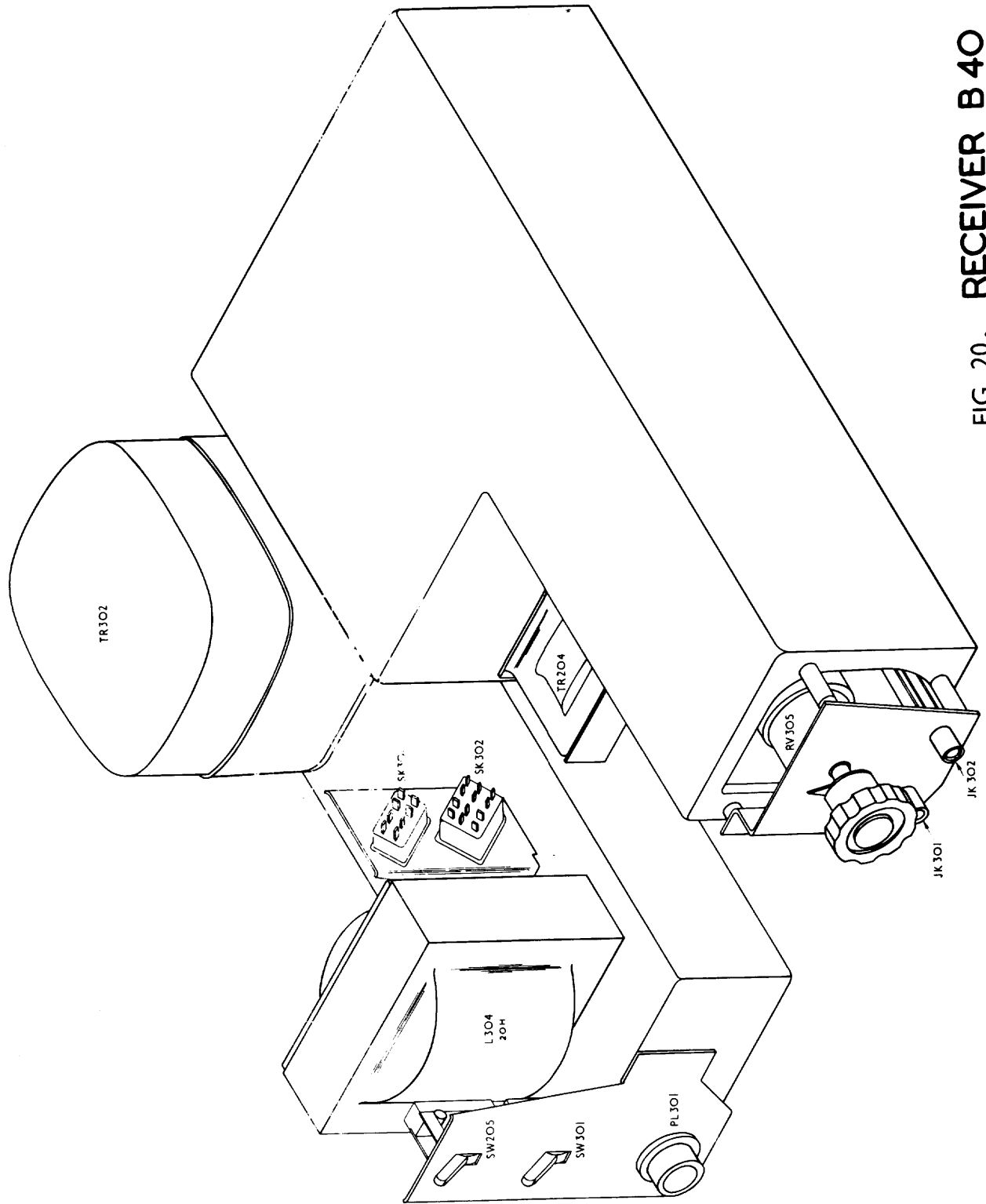

FIG. 20. RECEIVER B 40 AP.57140B/C
A.F. & POWER UNIT. TOP LAYOUT.

COMPONENTS LIST RECEIVER B40

PATTERNS 57140B/C

A. F. AND POWER UNIT

CAPACITORS

Ref.	A.P. or Joint Service Cat. No.	Value	Tol.	Rating	Remarks
C303	Z115506	0.1 μ F	20%	350V	
C304	Z115500	0.001 μ F	20%	1000V	
C305	Z112521	4 μ F	20%	400V	
C306	Z112521	4 μ F	20%	400V	
C309	Z124409	0.01 μ F	20%	750V	
C310	Z124409	0.01 μ F	20%	750V	
C311	Z124409	0.01 μ F	20%	750V	
C312	Z124409	0.01 μ F	20%	750V	
C313	Z115502	0.005 μ F	20%	1000V	
C314	Z112934	8 μ F	20%	400V	
C315	Z112934	8 μ F	20%	400V	
C316	Z115516	0.02 μ F	10%	750V	
C317	Z115574	0.1 μ F	10%	350V	
C318	Z115500	0.001 μ F	20%	1000V	
C319	Z115632	1 μ F	20%	350V	

RESISTORS

Ref.	A.P. or Joint Service Cat. No.	Value	Tol.	Rating	Remarks	
R301	Z223207	2.2M ohms	10%	$\frac{3}{4}$ W	Variable	
R302	Z223017	68k ohms		$\frac{1}{2}$ W		
R303	Z223101	330k ohms		$\frac{1}{2}$ W		
R304	Z221227	820 ohms		$\frac{1}{2}$ W		
RV305	Z273001	3k ohms				
R306	Z223122	470k ohms	10%	$\frac{1}{2}$ W	Variable	
R307	Z222215	47k ohms		$\frac{1}{2}$ W		
R308	Z221123	120 ohms		$\frac{3}{4}$ W		
RV309	Z273001	50 ohms				
R310	Z223144	680k ohms		$\frac{3}{4}$ W		
R311	Z244085	7.5k ohms	5%	4.5W) Alternatives to) R304 and R308 when) CV4043 is fitted.	
R312	Z222069	3.3k ohms		$\frac{3}{4}$ W		
R313	Z244114	15k ohms		6W		
R314	Z222090	4.7k ohms		$\frac{3}{4}$ W		
R304	022-1148	220 ohms	5%	$\frac{1}{4}$ W		
R308A	022-1192	470 ohms		$\frac{1}{2}$ W		
R308B	022-1192	470 ohms		$\frac{1}{2}$ W		

TRANSFORMERS

Ref.	Pattern No.	Description
TR301 TR302	65689 67763A	Output Transformer Mains Transformer

INDUCTORS

Ref.	Pattern No.	Description
L302 L303	65560 65564	Choke, 18H, Smoothing Choke, 10H, Smoothing

FUSES

Ref.	Pattern No.	Description
F301 F302 F303	Z590108 Z590110 Z590110	Fuse 0.5 Amp Fuse 2 Amp Fuse 2 Amp

PLUGS AND SOCKETS

Ref.	A.P. or Joint Service Cat. No.	Description
PL301 SK301 SK302	Z560050 W8369 60156	Plug, 2 Pin, Mains (Mark 4) Socket 8 way, IF/AF and Power Unit Socket 12 way, IF/AF and Power Unit

SWITCHES

Ref.	Pattern No.	Description
SW205 SW301	52805 60448	Monitor L.S. Switch Switch, Double Pole, Mains

JACKS

Ref.	Pattern No.	Description
JK301/2	676A	Jacks, 3 Pole, Telephones

FIG. 23

RESISTORS.				314		303		301	308	305	303	301	308	315	301
CAPACITORS.						318									
MISCELLANEOUS	PL 301	RV305	RV309	JK 302				TR301	V301	TR303	V302				
				JK 301											

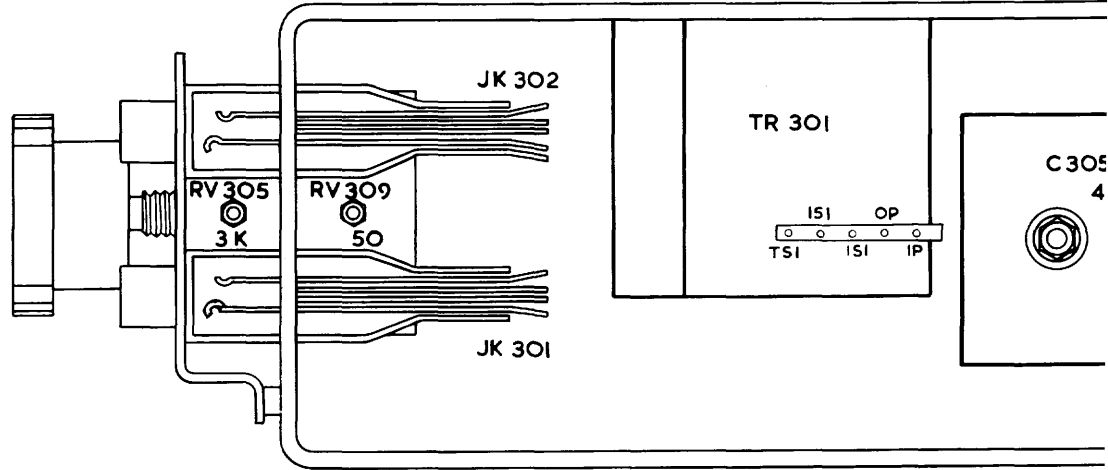

L 302 } a START OF WINDING COIL
 b FINISH OF WINDING COIL

VOLTAGES TAKEN WITH
 AVOMETER MODEL 8
 A.P. 12945.

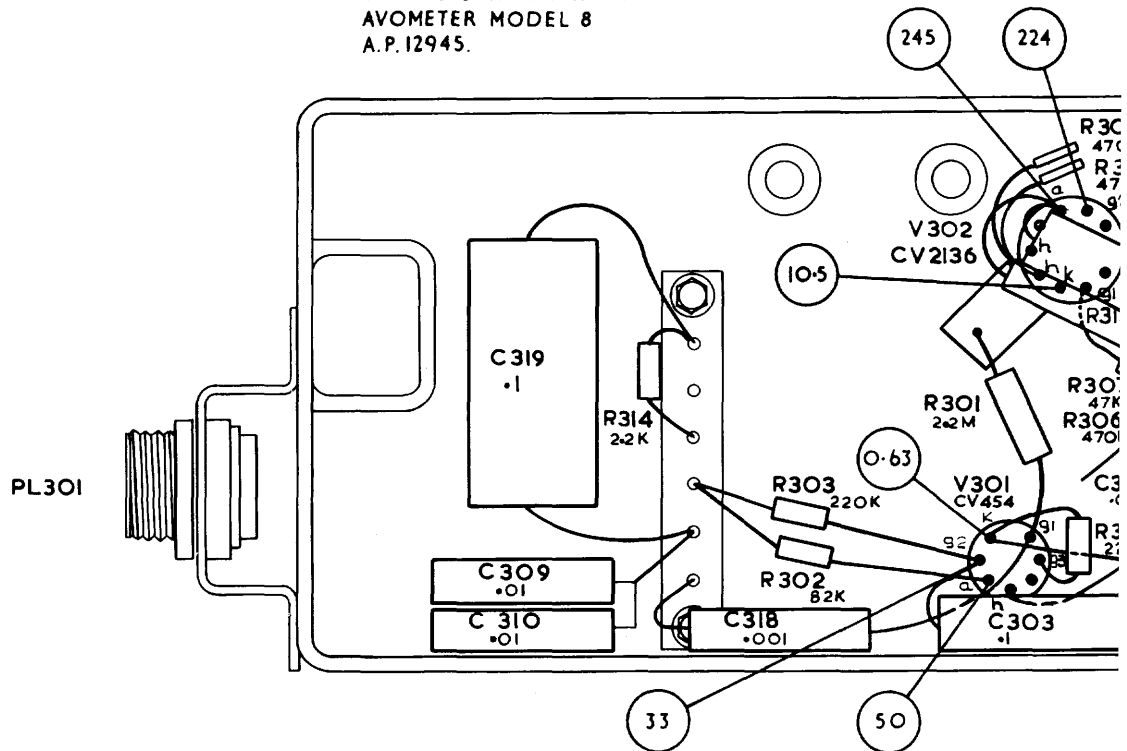

301	308 315	313 304	307 306	312	311		
	305 303	313 304		311 312	306	315 314	317 316
V301	TR303 V302		V305 V304 V303		TR302	L302	FS303 FS302 FS301

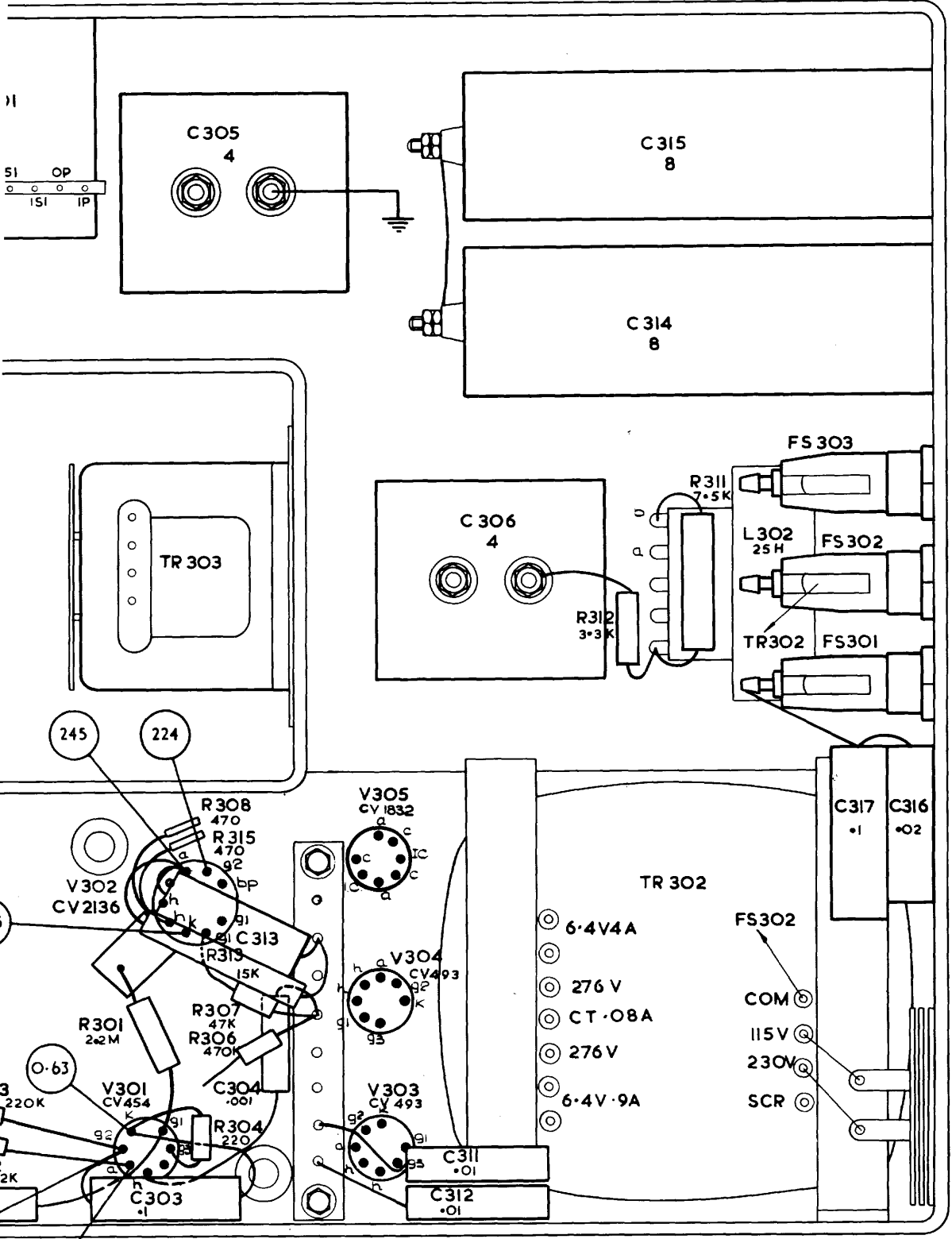

RECEIVER B40 A.P. 57140 D.
A.F. & POWER UNIT. BOTTOM LAYOUT.

TRANSFORMERS

Ref.	Pattern No.	Description
TR301 TR302	65689 67763A	Output Transformer Mains Transformer

INDUCTORS

Ref.	Pattern No.	Description
L302 L303	65560 65564	Choke, 18H, Smoothing Choke, 10H, Smoothing

FUSES

Ref.	Pattern No.	Description
F301 F302 F303	Z590108 Z590110 Z590110	Fuse 0.5 Amp Fuse 2 Amp Fuse 2 Amp

PLUGS AND SOCKETS

Ref.	A.P. or Joint Service Cat. No.	Description
PL301 SK301 SK302	Z560050 W8369 60156	Plug, 2 Pin, Mains (Mark 4) Socket 8 way, IF/AF and Power Unit Socket 12 way, IF/AF and Power Unit

SWITCHES

Ref.	Pattern No.	Description
SW205 SW301	52805 60448	Monitor L.S. Switch Switch, Double Pole, Mains

JACKS

Ref.	Pattern No.	Description
JK301/2	676A	Jacks, 3 Pole, Telephones

315	314	311	310					
RV 309	JK 301 JK 302	V303 V304	SK 302	FS 301	TR 302	FS 302 FS 303	SW 301	PL 301

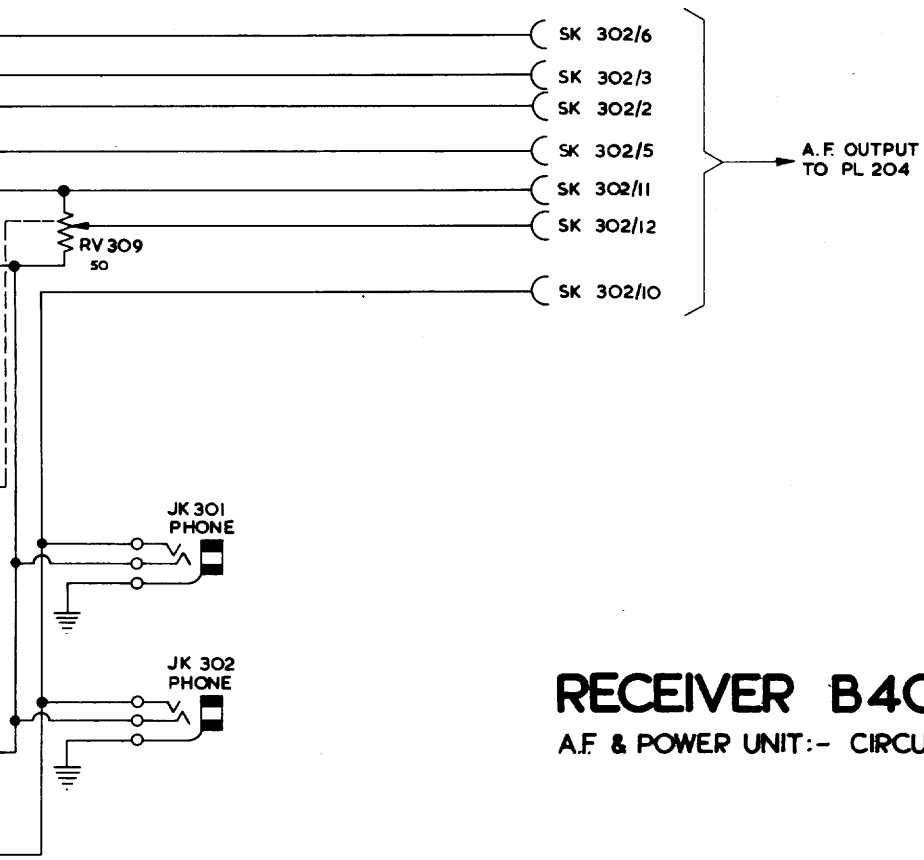
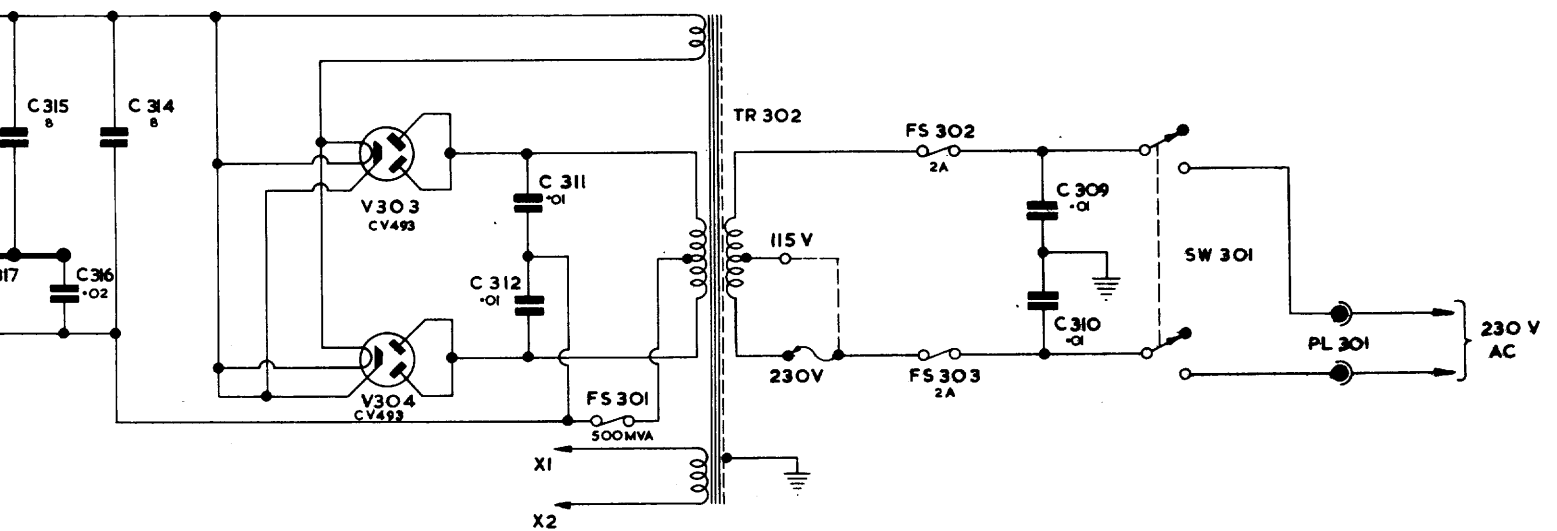

RECEIVER B40 A.P.57140 D
A.F. & POWER UNIT:- CIRCUIT DIAGRAM.

RESISTORS		301	302	303	312	311 314	306	307	313 308	315	
CAPACITORS		318	304	306 303	305	319	304	313		315 317	314 316
MISCELLANEOUS	SK301 SK302	RV 305	V301 TR303 SW302		V305			L 302 L 304	TR301 V302		RV 309

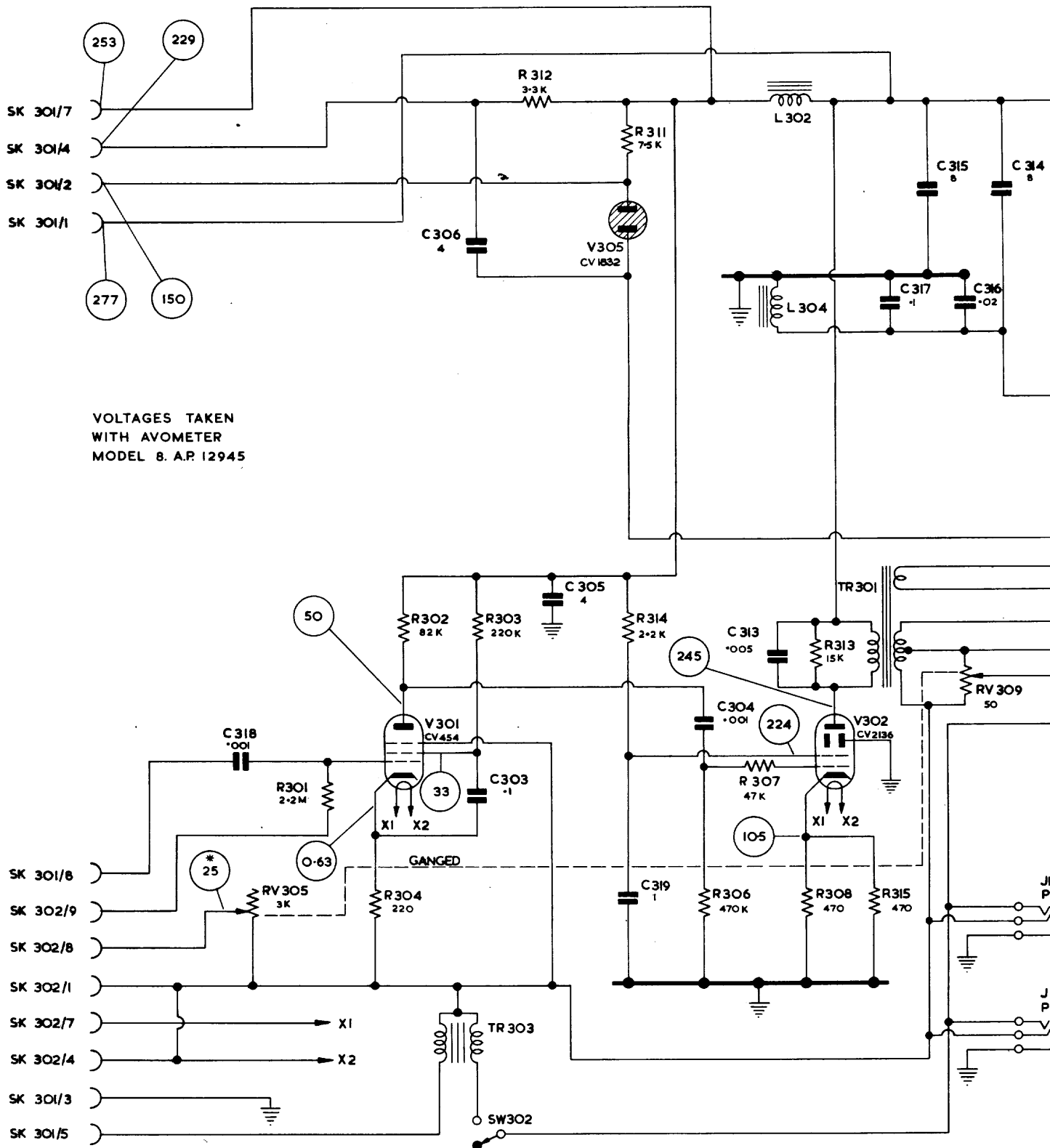

* CONTROL FULLY COUNTER - CLOCKWISE

COMPONENTS LIST, RECEIVER B40,

PATTERN 57140D

A.F. AND POWER UNIT

CAPACITORS

Ref.	A.P. or Joint-Service Cat. No.	Value	Tol.	Rating	Remarks
C303	011-7818	0.1 μ F	20%	350V	
C304	011-5500	0.001 μ F	20%	1000V	
C305	011-2926	4 μ F	20%	400V	
C306	011-2926	4 μ F	20%	400V	
C309	012-4409	0.01 μ F	20%	750V	
C310	012-4409	0.01 μ F	20%	750V	
C311	012-4409	0.01 μ F	20%	750V	
C312	012-4409	0.01 μ F	20%	750V	
C313	011-7827	0.005 μ F	20%	1000V	
C314	932-2513	8 μ F	20%	400V	TCC Type 82
C315	932-2513	8 μ F	20%	400V	TCC Type 82
C316	580-1816	0.02 μ F	10%	350V	
C317	911-6793	0.1 μ F	10%	350V	TCC Type 82 CP.45N
C318	011-5500	0.001 μ F	20%	1000V	
C319	011-7821	1 μ F	20%	350V	

RESISTORS

Ref.	A.P. or Joint-Service Cat. No.	Value	Tol.	Rating	Remarks
R301	022-3206	2.2M ohms	10%	$\frac{3}{4}$ W	
R302	022-3028	82k ohms	10%	$\frac{1}{2}$ W	
R303	022-3079	220k ohms	10%	$\frac{1}{2}$ W	
R304	022-1151	220 ohms	10%	$\frac{1}{2}$ W	
R306	022-3121	470k ohms	10%	$\frac{1}{2}$ W	
R307	022-2214	47k ohms	10%	$\frac{1}{2}$ W	
R308	022-1195	470 ohms	10%	$\frac{3}{4}$ W	
R311	011-3508	7.5k ohms	5%	4 $\frac{1}{2}$ W	Wirewound
R312	022-2069	3.3k ohms	10%	$\frac{3}{4}$ W	
R313	011-3425	15k ohms	5%	6W	Wirewound
R314	022-2048	2.2k ohms	10%	$\frac{3}{4}$ W	
R315	022-1195	470 ohms	10%	$\frac{3}{4}$ W	

VARIABLE RESISTORS

Ref.	A.P. or Joint-Service Cat. No.	Value	Tol. ±	Rating	Remarks
RV305/9	972-9485	3k/50 ohms	10%		Ganged RF/AF Gain

TRANSFORMERS

Ref.	A.P. or Joint-Service Cat. No.	Description
TR301	971-9621	Audio Output Transformer
TR302	971-9596	Mains Transformer
TR303	971-9513	Monitor Loudspeaker Transformer

INDUCTORS

Ref.	A.P. or Joint-Service Cat. No.	Description
L302	971-9618	Choke 18-25H - Smoothing
L304	971-9595	Choke 20H - Smoothing

FUSES

Ref.	A.P. or Joint-Service Cat. No.	Description
F301	059-0108	500 mA Cartridge Fuse
F302/3	059-0110	2A Cartridge Fuse

PLUGS AND SOCKETS

Ref.	A.P. or Joint-Service Cat. No.	Description
PL301	999-3528	Plug 2 Pin, Mark 4, Mains Input
SK301	972-8232	Socket 8 Pin, Interconnecting (IF/AF and Power Unit)
SK302	972-8233	Socket 12 Pin, Interconnecting (IF/AF and Power Unit)

SWITCHES

Ref.	A.P. or Joint-Service Cat. No.	Description
SW301	933-0018	Switch, 2 position - Mains
SW302	972-5014	Monitor L.S. Switch

JACKS

Ref.	A.P. or Joint-Service Cat. No.	Description
JK301/2	972-9652	Jack - 3 Pole

FIG. 25

R	101	103	104	105	107	106	108	109	110	111	112	113	114	116	117	120	R											
C	101	102	104	111	112	106	131	135	134	133	132	118	114	115	117	116	119	120	121	138	122	126	124	127	128	129	C	
MISC	PLIO1	TRIO1	RV102	SWIO1	VIO1				TRIO2				VIO2	TRIO3	VIO3	VIO4	TRIO4	SKIO1	PLIO3	MISC								
	SWIO2a	LP101-107	RV125		SKIO2				LIO2	SWIO2b	XLIO1	SWIO2c		LIO1	SWIO2d													

R.F. UNIT

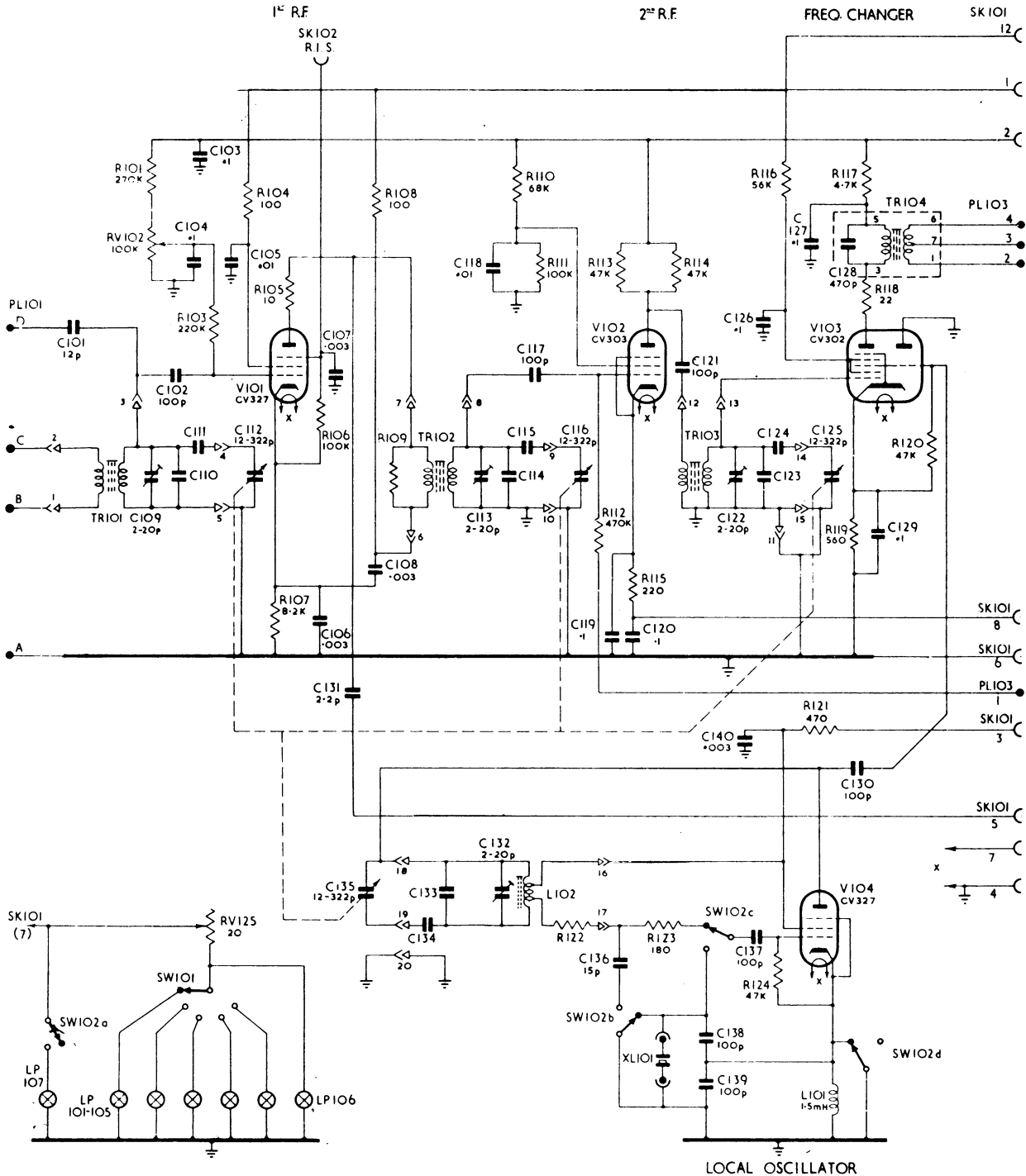

NOTE:- REFER TO FIG. 2 PT. 3 FOR VALUES OF COMPONENTS IN TURRET COMPARTMENTS.

4.211. 215 229. 228.230.232.	221. 222.219.	225. 223.226.	312. 301.310.304. 302.	311. 303.	303. 306.307.308.	R	
214. 215.	226. 228.	227. 229.	306. 301.302.	305. 303.	307. 304.	308. 313.	
235.	224. 225. 231.	230.	306. 301.302.	303.	304.	311. 312.	
TR.203.V.206. RV.220. SW.203.V.205.	V.204b. RV.224. SW.202f. SW.202e. SW.202d.	SW.202h. PL.204. SK.301. SK.203 RV.305. L.301.	V.304. V.301	L.302 L.303	V.303. TR.301	FS.301. TR.302. SW.301. PL.301. SK.302. FS.302. FS.303	MISC.
205.	SW.202n.	SW.202f. SW.202e. SW.202d.	SW.201d.		V.302 RV.309	JK 301, 302.	

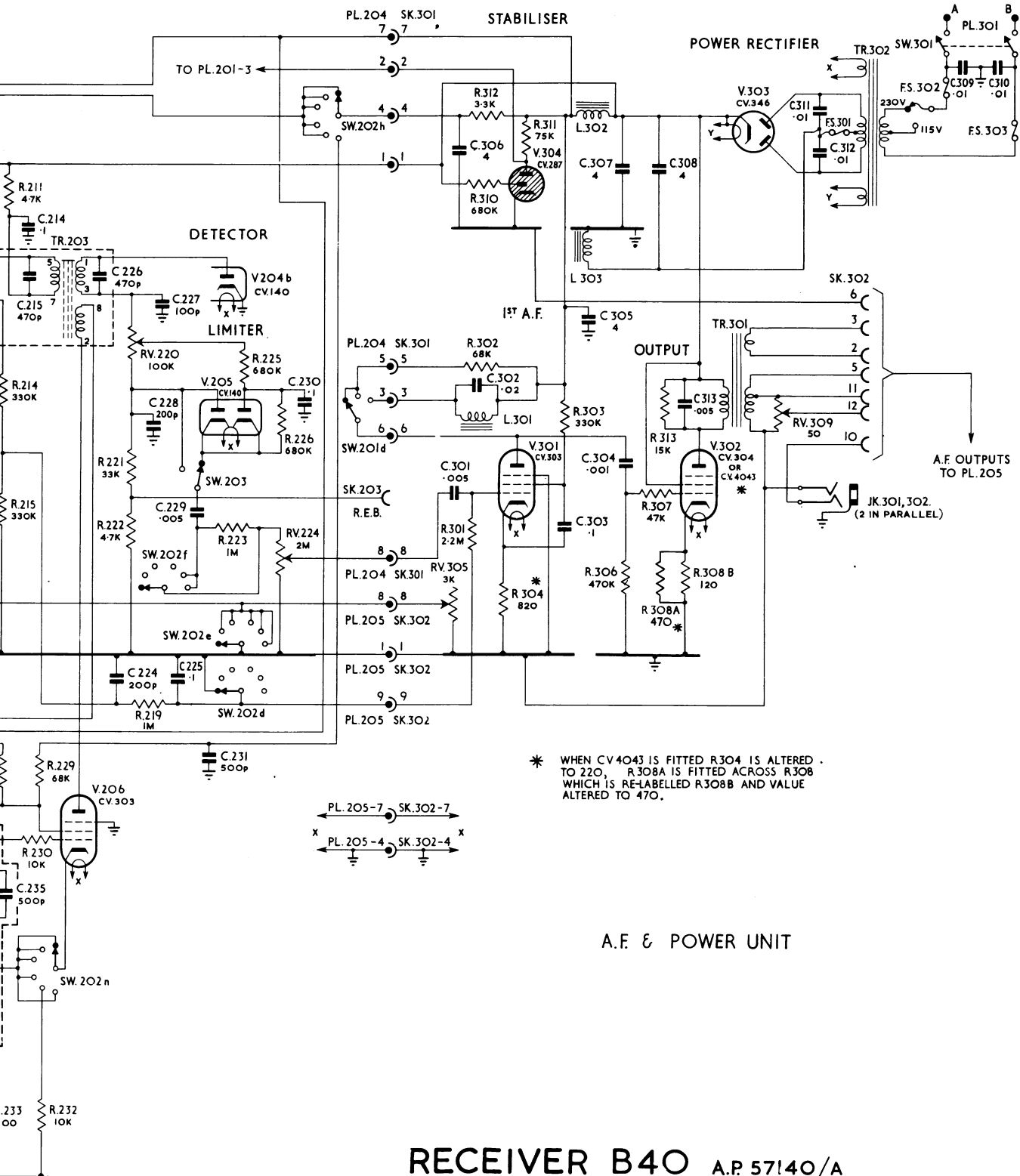

R	202.201. 218.203. 234.	204.	206.205. 207.	208.	209.235. 210. 217.	212. 227. 213.	216.214.211. 231.215. 229. 233.228.230.232.	221. 222.219.		
C	201. 223. 238.	202. 203.	204. 205.	206. 222.	207. 221.	209. 220.208. 210. 219.	211. 212. 213.	217. 216. 232. 233. 234. 237. 218. 235.	214. 215. 224.	226. 227. 228. 229. 225. 231.
MISC	PL.201. SW.201a. SK.201. PL.203. TL.	L.201. V.201. TR.204.	SW.202a. SW.205. SW.204. SW.202g. L.S.201. PL.205.	TR.201. SW.201b. V.202. SW.202j.	SW.202b.	TR.202. SW.202c. SW.202g. L.203. L.204. SK.202. SW.201e. SW.202k. SW.202p. XL.201. SW.202m. L.202. L.205.	V.203. V.204a. TR.203. V.206. RV.220. SW.203V. SW.202f. SW.202	V.206. V.203V. SW.202n. SW.202f. SW.202		

I.F. UNIT

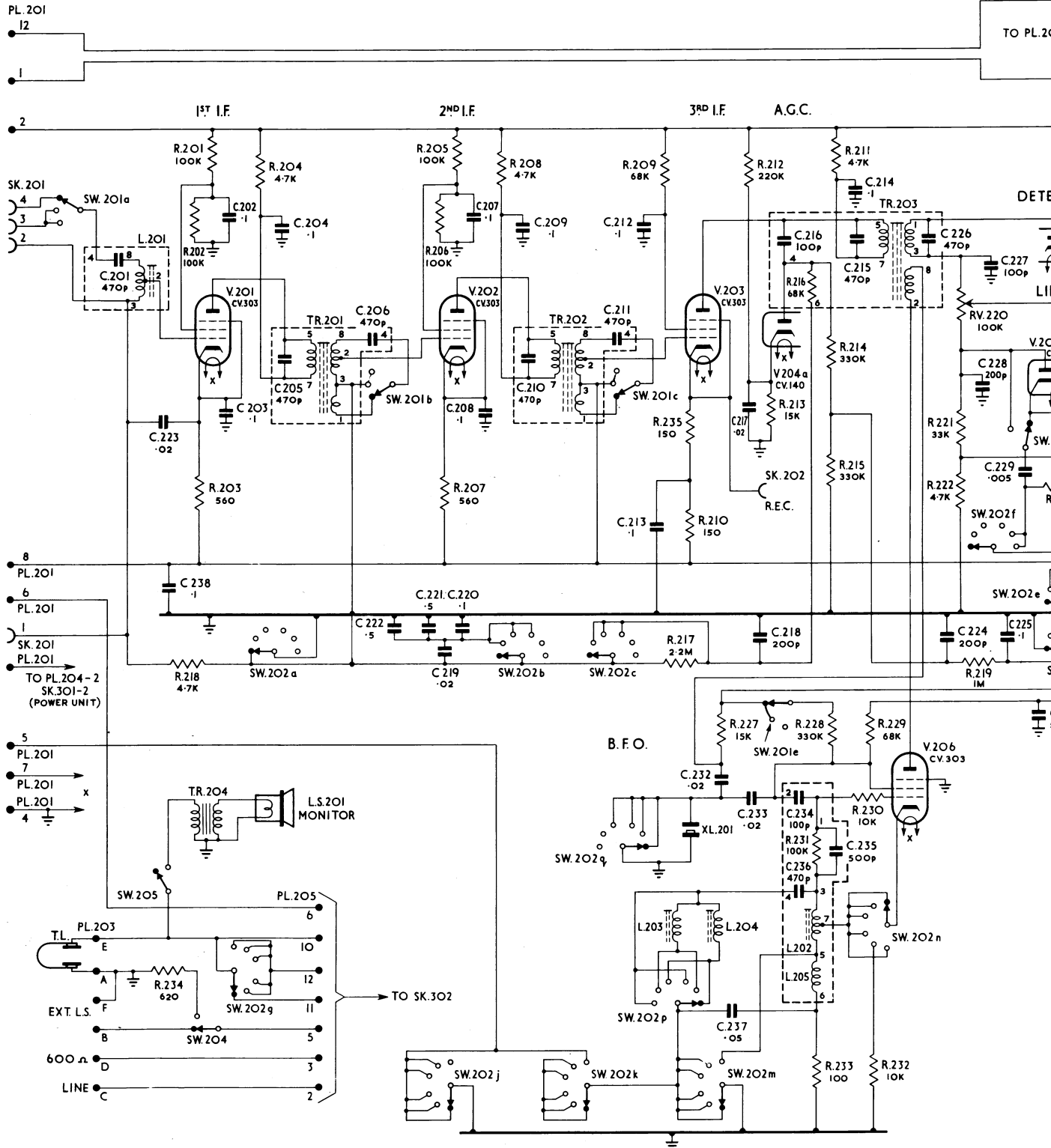
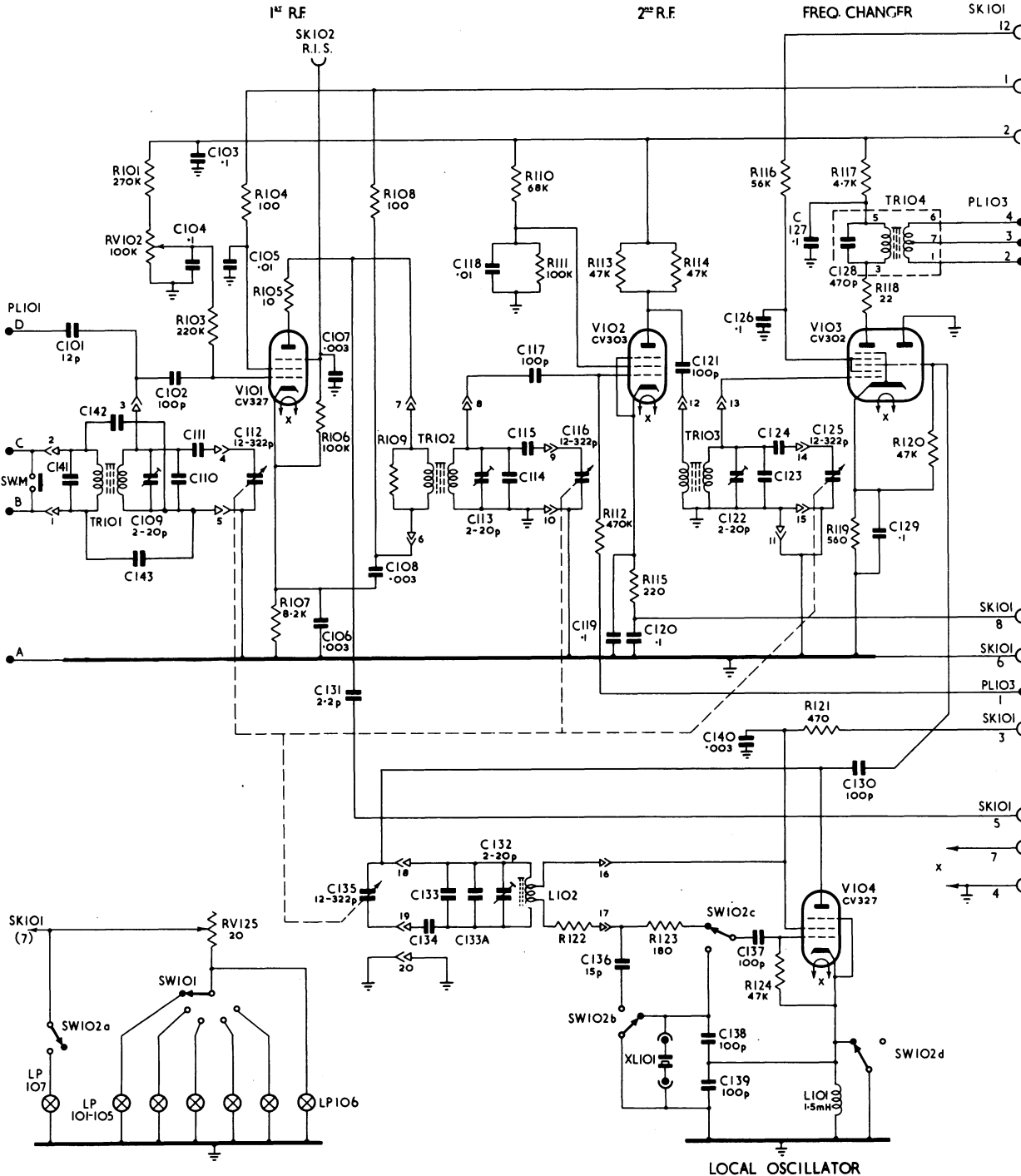

FIG. 26

R		IO1	IO3	IO4	IO5	IO6	IO8	IO9		IO10	IO11	IO12	IO13	IO14		IO16	IO17	IO18	IO20	R								
C	IO1	IO3	IO5		IO7	IO8		IO11	IO12	IO13	IO14	IO15	IO16	IO17	IO18	IO19	IO20	IO21	IO22	IO23	IO24	IO25	IO26	IO27	IO28	IO29	IO30	C
MISC	PLIO1	RVIO2			VIO1			TRIO2			VIO2	TRIO3		VIO3	VIO4		TRIO4	SKIO1	PLIO3	MISC								
	SWM	TRIO1	SWIO1																									
	SWIO2a	LP IO1-IO5	RV125		SK IO2							SWIO2b	XLIO1	SWIO2c														

R.F. UNIT



NOTES:-

1. THE FOLLOWING COMPONENTS ARE ONLY FITTED TO PATT. 57140C - C141, C142, C143 AND SWM.
2. THE HIGH IMPEDANCE AERIAL CONNECTION TO PLIO1 D, INCLUDING C101, IS OMITTED IN PATT. 57140C
3. C133A IS FITTED ONLY IN PATT. 57140B/C
4. REFER TO FIG. 2, PT. 3 FOR VALUES OF COMPONENTS IN TURRET COMPARTMENTS

FIG. 26

213	231	236	211	232		219	225		301	312	311	303	314	307	313		R
	235	229				221	223	226		302				306	308		
	228	233	237	230		222			310	304							
216		215	214			226	227	230			303		315	316		309	C
	234	235				224	224	225		306	318		319	317	313	314	310
	236					228	231						305	304			
V204a	TR203	V206				RV220	V205	V204b	SW202h	PL204	SK301	V304	L302		V303	RV309	SW301
L202							SW203	SW20bc				V301	L304		V302	FS301	SK302
L205	SW202n					SW202f	LS	SW20bb	RV224	SK203	RV305	TR204	SW205		TR301	TR302	FS302
																	FS303

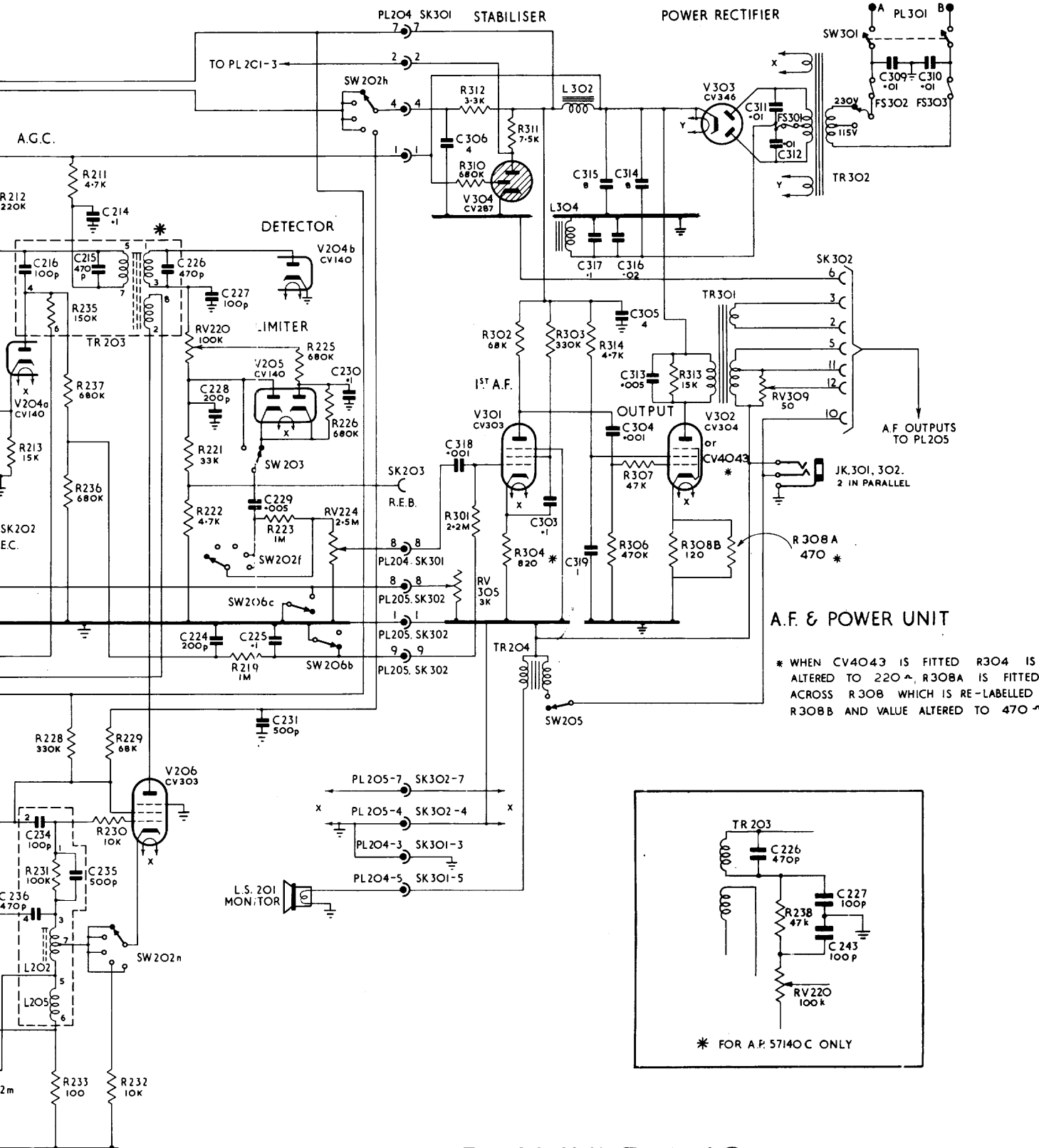

A.F. & POWER UNIT

* WHEN CV4043 IS FITTED R304 IS ALTERED TO 220Ω. R308A IS FITTED ACROSS R308 WHICH IS RE-LABELLED R308B AND VALUE ALTERED TO 470Ω

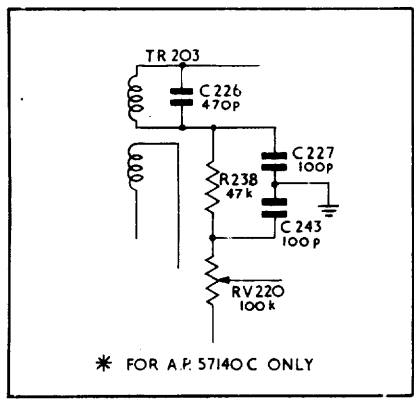

* FOR A.P. 57140C ONLY

RECEIVER B40. A.P. 57140B/C. CIRCUIT DIAGRAM.

7	215	226	235	227	231	233	230	306	303	317	316	315	314	312	309	310	C
	216	224	237	236	249	228	229	318	305	319	304	303	313	311			R
212	213	235	237	232	238	231	225	32	311	301	302	303	307	313	315		
		213	236		221	220	228	245	246	248	247	304	314	306	308		
2	SW202n	TR203	SW202h	SW203	V205	SW202f	LS201	V305	L304	L302	V304	F5301	SK302	F5303	SK301	PL301	MISC.
	SW202m	V204b	L202	RV220	SW206c	SW206b	XL201	V301	TR303	TR302	V303	TR302	JK302	F5303	SW301		
		V206	L205	SK203	SW202p	RV224	SW202q	RV305	SW302	SW302	V302	TR301	RV309	JK301	F5302	PL301	

A.F. & POWER UNIT

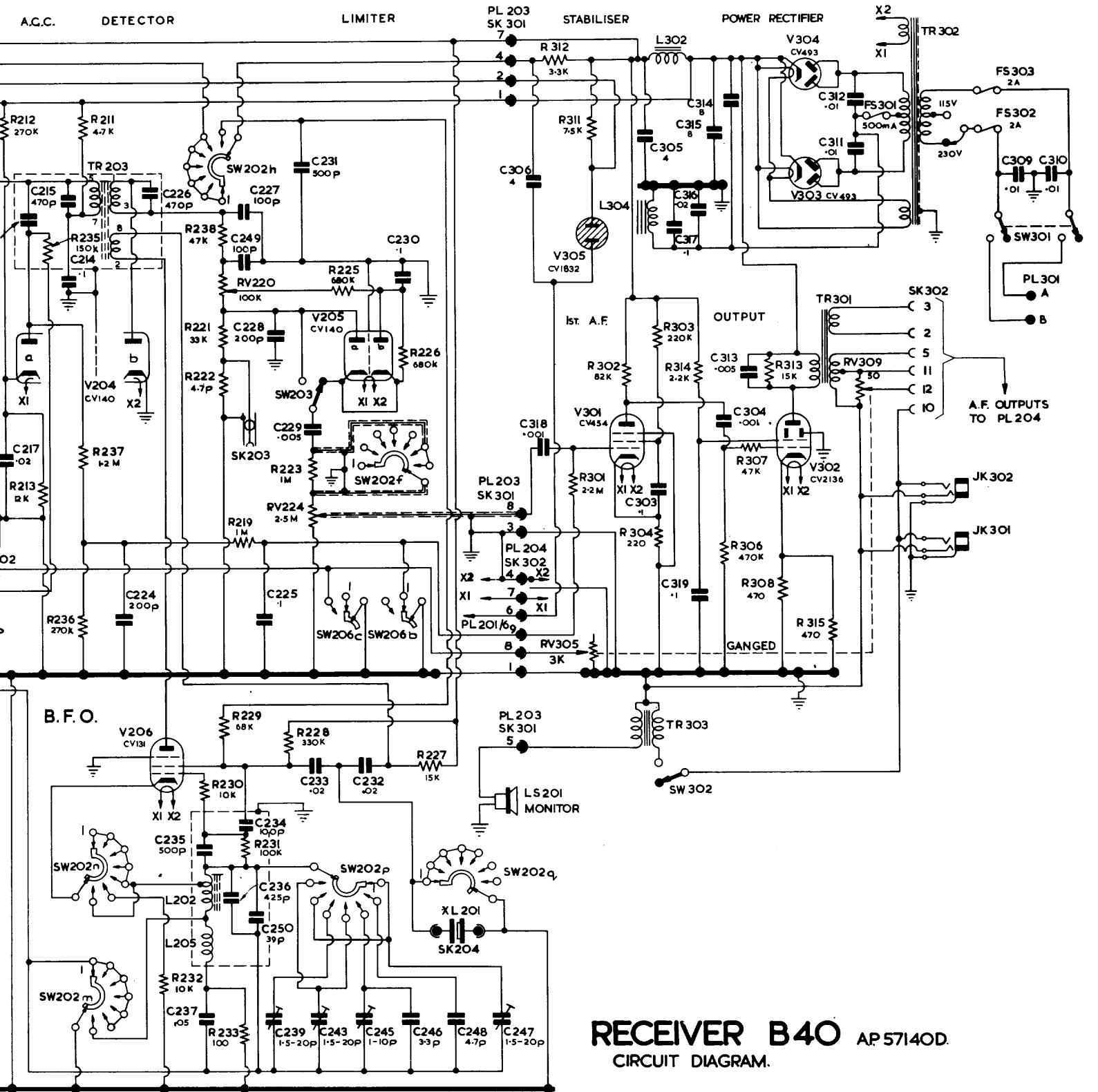

RECEIVER B40 AP57140D.
CIRCUIT DIAGRAM.

C	238	201	202	204	206	240	222	241	207	210	212	217	215	226	2		
R		223	203	205			222	221	220		211	213	218	216	214	224	23
MISC.	PL 201 SK 201	SW 201a SW 202j SW 202k	L 201 PL 202	V 201	TR 201 SW 206a SW 204	SW 201f SW 201j SW 201b XL 202		SW 201g SW 201h SW 201k SW 206d L 206	V 202 PL 204	TR 202 SW 201c	V 203 SK 202	SW 202n SW 202m	V 204b	TR 203 V 206			

I.F. UNIT

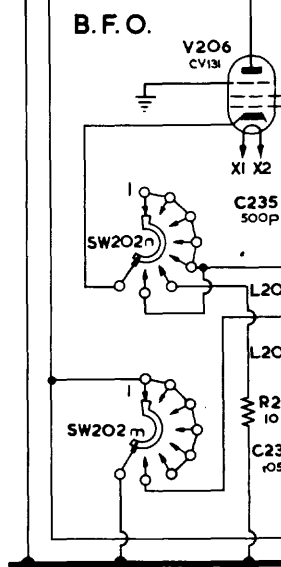
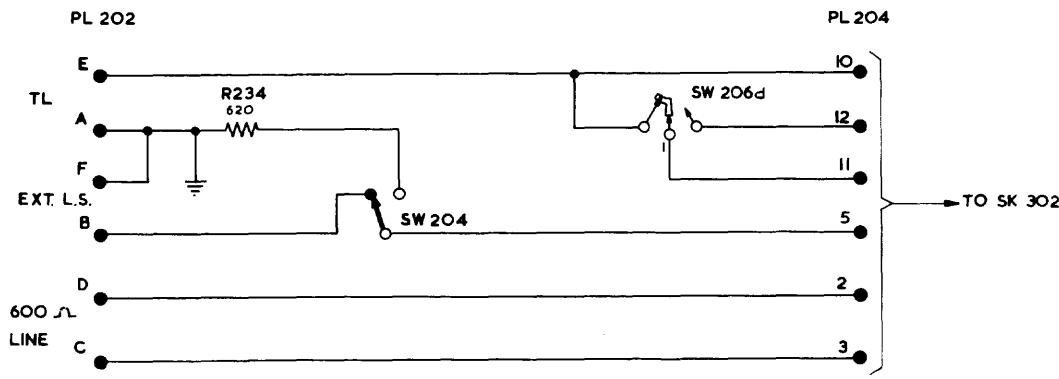
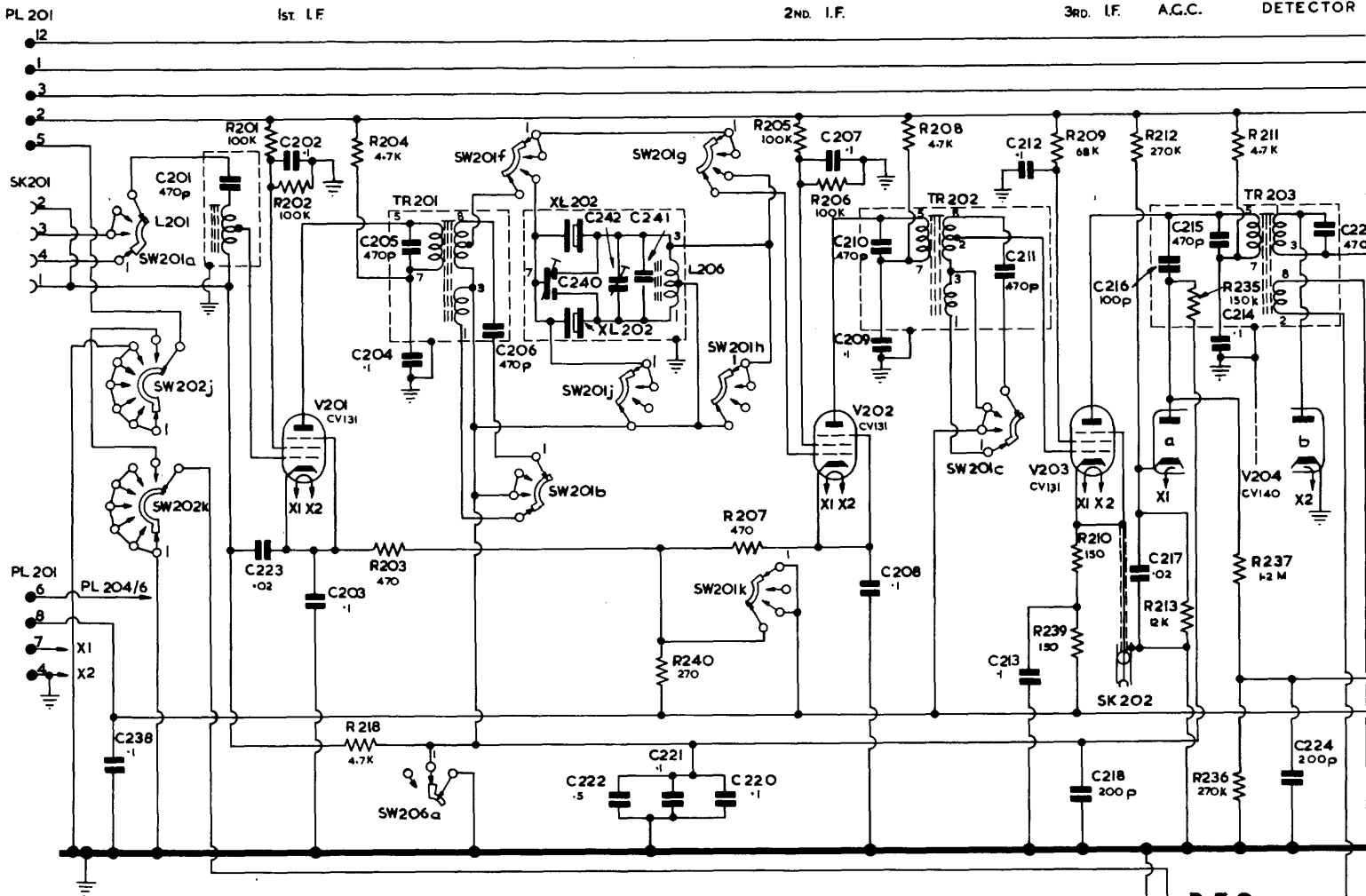

REPAIR AND WINDING DATA FOR COILS

The following pages give details concerning the coils for the various transformers, chokes and similar components through-out the receiver. All patterns are covered by this information. Winding data is not given for the later types of iron cored transformers and chokes, as these items are not repairable, it is important therefore, that spares of these items should be available. Details are given concerning the rating and general characteristics of these components so that in the case of a real emergency where no direct spare is available, a suitable substitute could be fitted.

When re-winding a coil, it should be noted that when a solenoid winding is to be started a given distance from the base of the former, the starting washer should be located along the former by wrapping two turns of 0.005" x 1/8" Lassothy! Tape on the former so that the top edge of the tape is 1/32" nearer the base of the former than the required starting point of the winding.

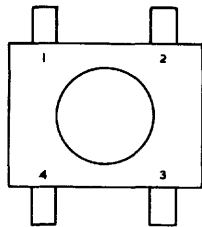

All references to direction of winding refer to this position.

Coil from the base showing the tag positions
(Refers to all turret coils)

Note. The circuit references quoted on the following diagrams relate to B40/A/B/C receivers. The corresponding B40D references can be obtained from the circuit diagram Fig. 27.

AERIAL COIL BAND 1 (TRIOI)

WINDING DATA

PRIMARY WINDING

Start Tag 4. Finish Tag 3.
 9½ turns anti-clockwise of 40 S.W.G. enamel wire.
 Winding Type - solenoid, close wound, anchored by means of a washer put on to the former before the main winding.
 Finish - start and finish held by one washer, after the main winding.

SECONDARY WINDING

Start Tag 2. Finish Tag 1.
 87½ turns clockwise, 3/42 enamel and S.F.C. wire.
 Length of winding - 1/8".
 Winding Type - single wave 51/54.
 Wound on Douglas Gears - A.50, B.36, C.34, D.50, E.60, F.60.
 Finish - Two washers at the start and finish.
 Distrene Lacquered.

Vacuum impregnated and wax dipped.

Colour coding on Plate:- Red, Red, Blue.

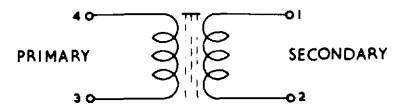
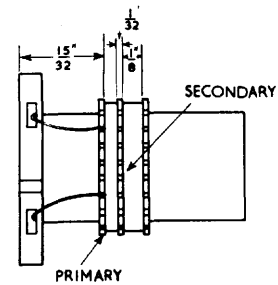

AERIAL COIL BAND 1 (TR101) Patterns 57140C/D Only

WINDING DATA

PRIMARY WINDING (wound after Secondary)

Winding to progress along former to base.

Start Tag 3. Finish Tag 4 (Start directly under secondary winding).

4½ turns anti-clockwise, (direction of rotation of former, looking along the former towards the base) of 28 S.W.G. enamel S.S.C. wire.

Winding Type - Close wound solenoid anchored by a washer put on former before secondary winding.

Finish - Finish held with one washer.

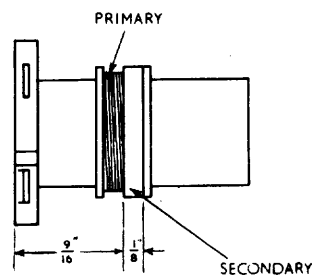

SECONDARY WINDING

Start Tag 2. Finish Tag 1.

87½ turns clockwise (direction of rotation of former looking along the former towards the base), 3/42 S.W.G. enamel and S.F.C. wire.

Length of Winding - 1/8".

Winding Type - Single Wave 51:54.

Wound on Douglas Gears A.50, B.36, C.34, D.50, E.60, F.60.

Finish - Finish held with 1/8" x 0.005" Lassothyl Tape 5, No. 3711/9.

First few turns to be secured to the former by a smear of thin Polystyrene varnish.

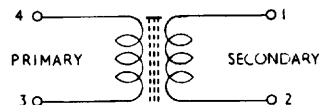

Vacuum impregnated and wax dipped.

Colour Code - Red, Red, Green.

FIG. 31

AERIAL COIL BAND 2 (TRIOI)

WINDING DATA

PRIMARY WINDING

Start Tag 3. Finish Tag 4.
 $4\frac{1}{2}$ turns anti-clockwise, 38 S.W.G. wire, D.F.C.
Winding Type - solenoid, wound after Secondary winding.

SECONDARY WINDING

Start Tag 2. Finish Tag 1.
 $38\frac{1}{2}$ turns anti-clockwise, 38 S.W.G. enamel and
D.F.C. wire. Note that both windings start $\frac{1}{2}$ "
from the former base; the primary winding over-
lapping the secondary. Finish at the end washer.
Seal both start and finish with Distrene Lacquer.

The coil should then be vacuum impregnated and
wax dipped.

Colour Code on Plate:- Red, Yellow, Blue.

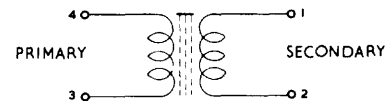
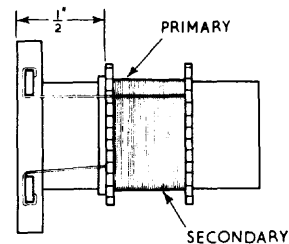

AERIAL COIL BAND 2 (TR101)

Patterns 57140C/D Only

WINDING DATA

PRIMARY WINDING (wound before Secondary)

Start Tag 4. Finish Tag 3.
 32 turns anti-clockwise (direction of rotation of the former, looking along the former towards the base) of 28 S.W.G. enamelled S.S.C. wire.
 Winding Type - Solenoid.
 Start and Finish - on washers holding winding.
 Start 1/32" below secondary winding, i.e. there should only be the width of the spacing washer between windings.

SECONDARY WINDING

Start Tag 2. Finish Tag 1. (Start 1/2" from the base of the former.)
 38 turns anti-clockwise (direction of rotation of the former, looking along the former towards the base) of 38 S.W.G. enamelled and S.F.C. wire.
 Finish - Tag 1, Anchor at washer.
 Winding Type - Close wound solenoid.

Start and Finish - Distrene Lacquer.

Vacuum impregnated and wax dipped.

Colour Code - Red, Yellow, Green.

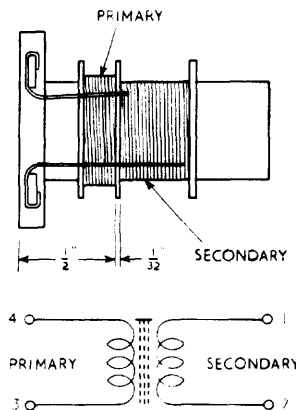

FIG. 33

AERIAL COIL BAND 3 (TR101)

WINDING DATA

PRIMARY WINDING

Start Tag 3. Finish Tag 4.
2½ turns anti-clockwise.
Start 9/16" from the former base, using
38 S.W.G. wire, D.F.C.
Winding Type - solenoid.
Finish - Two washers.
Distrene Lacquer.

SECONDARY WINDING

Start Tag 2. Finish Tag 1.
13½ turns anti-clockwise of 32 S.W.G. wire, D.F.C.
Start 9/16" from the former base.
Winding Type - Close wound solenoid.
Finish - Two washers - Distrene Lacquer.

The coil should then be vacuum impregnated and
wax dipped.

Colour Code on Plate:- Blue, Green, Red.

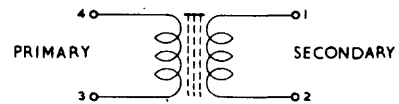
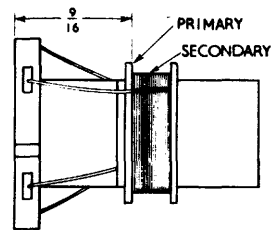

FIG. 34

AERIAL COIL BAND 3 (TR101)

PATTERNS 57140C/D ONLY

WINDING DATA

PRIMARY WINDING (wound after Secondary)

Start Tag 3. Finish Tag 4.
22 turns clockwise (direction of rotation of the former looking along the former towards the base) of 28 S.W.G. enamelled S.S.C. wire.
Type of winding - Solenoid.
Start and Finish - on washers holding the winding.

SECONDARY WINDING

Start Tag.2. Finish Tag 1.
13½ turns anti-clockwise (direction of rotation of the former looking along the former towards the base) of 32 S.W.G., D.F.C. wire, start 9/16" from base.
Type of winding - Close wound solenoid.
Finish at the washers - Distrene Lacquer.

Vacuum impregnated and wax dipped.

Colour Code - Red, Green, Green.

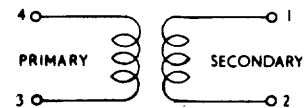
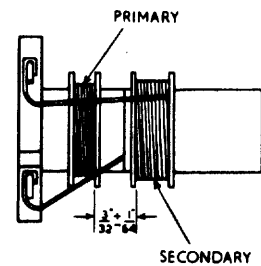

FIG. 35

AERIAL COIL BAND 4 (TRIOI)

WINDING DATA

PRIMARY WINDING

Start Tag 4. Finish Tag 3.
Start $9/16$ " from the former base.
 $1\frac{1}{2}$ turns clockwise of 38 S.W.G. wire, D.F.C.
 $\frac{3}{4}$ turn interwound with the secondary winding
at the end nearest to the base of the former.
Winding Type - Solenoid.
Finish - Ends held with $.005$ " x $\frac{1}{4}$ " Lassothy Tape.

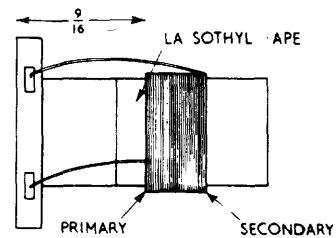

SECONDARY WINDING

Start Tag 2. Finish Tag 1.
 $7\frac{1}{2}$ turns clockwise of 24 S.W.G. enamel wire,
starting $9/16$ " from the former base.
Winding Type - Solenoid.
Finish - Self supporting on tags.
Distrene Lacquer.

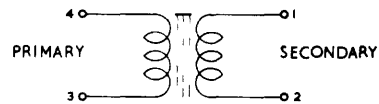

Colour Code on Plate:- Red, Blue, Blue.

FIG. 36

AERIAL COIL BAND 5 (TR101)

WINDING DATA

PRIMARY WINDING (Wound after the Secondary)

Start Tag 4. Finish Tag 3.
 Start $19/32$ " from the former base.
 $2\frac{1}{2}$ turn anti-clockwise of 38 S.W.G. wire, D.F.C.
 $\frac{1}{4}$ turn inter-wound with the secondary winding
 at the end nearer to the base of the former.
 Winding Type - Solenoid.
 Finish - Ends held with $.005$ " x $\frac{3}{4}$ " Lassothyl Tape.

SECONDARY WINDING

Start Tag 2. Finish Tag 1.
 Start $5/8$ " from the former base.
 $3\frac{1}{2}$ turns anti-clockwise of 20 S.W.G. wire, enamel.
 Length of winding - 0.290 "
 Finish - Self supporting on tags.

Vacuum impregnated and wax dipped.

Colour Code on Plate:- Red, White, Blue.

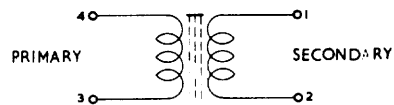
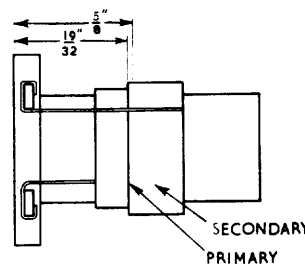

FIRST R.F. COIL BAND 1 (TR102)

WINDING DATA

PRIMARY WINDING (Wound before Secondary)

Start Tag 3. Finish Tag 4.
 Start $\frac{1}{4}$ " from the former base.
 600 $\frac{1}{2}$ turns clockwise of 39 S.W.G. wire, D.F.C.
 Winding Type - Half wave 31:63.
 Wound on Douglas Gears A.31, B.48, C.32, D.42,
 E.60, F.60.
 Finish - Held with Lassothyl Tape.

SECONDARY WINDING

Start Tag 2. Finish Tag.1.
 Start $\frac{13}{32}$ " from the Primary Coil
 87 $\frac{1}{2}$ turns clockwise of 39 S.W.G. wire, D.F.C.
 Winding Type - Single wave 51:54.
 Wound on Douglas Gears A.50, B.36 C.34 D 50,
 E.60 F.60.
 Finish - One washer and Distrene Lacquer.
 Both ends of the winding sleeved with art
 silk sleeving 2 m/m.

Vacuum impregnated and wax dipped.

Colour Code on Plate:- White, Red, Blue.

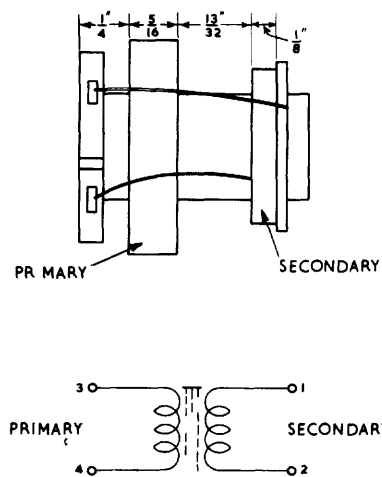

FIRST R.F. COIL BAND 2 (TR102)

WINDING DATA

PRIMARY WINDING

Start Tag 4. Finish Tag 3.
 300½ turns clockwise of 39 S.W.G. wire, D.F.C.
 Start ¼" from the former base.
 Winding Type - Half wave 31:63.
 Douglas Gears A.31, B.48, C.32, D.42, E.60, F.60.
 Finish - Ends held with .005" x ¼" Lassothy] Tape.

SECONDARY WINDING

Start Tag 2. Finish Tag 1.
 38½ turns anti-clockwise of 38 S.W.G. wire enamel
 and D.F.C.
 Start 7/32" from the Primary coil.
 Winding Type - Close wound solenoid.
 Finish - Two washers, one at the start and one at
 the finish.
 Distrene Lacquer.

Vacuum impregnated and wax dipped.

Colour Code on Plate:- Red, Yellow, Blue.

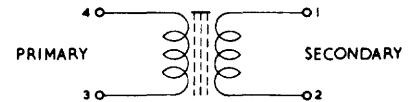
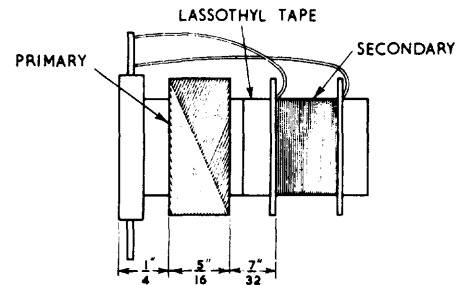

FIRST R.F. COIL BAND 3 (TR102)

WINDING DATA

PRIMARY WINDING

Start Tag 4. Finish Tag 3.
 120½ turns clockwise of 36 S.W.G. wire D.F.C.
 Start ¼" from the former base.
 Winding Type - Single wave 51:54.
 Length of winding - 1/8"
 Douglas Gears - A.50, B.36, C.34, D.50, E.60, F.60.
 Finish - One washer.

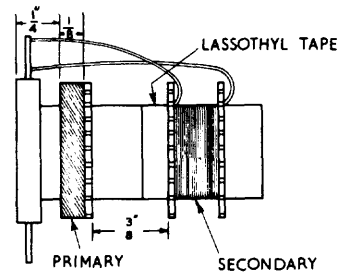

SECONDARY WINDING

Start Tag 2, Finish Tag 1.
 13½ turns anti-clockwise of 32 S.W.G. wire, D.F.C.
 Start 3/8" from the Primary Winding.
 Winding Type - Close wound solenoid.
 Finish - Two washers one at the start and one at the finish.
 Distrene Lacquer.
 Both ends of this winding to be sleeved with 2 m/m art silk sleeving to insulate them from the Primary Winding.

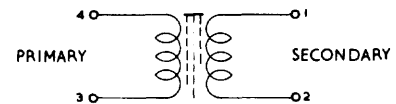

Colour Code on Plate:- White, Green, Blue.

FIG. 40

FIRST R.F. COIL BAND 4 (TR102)

WINDING DATA

PRIMARY WINDING

Start Tag 3. Finish Tag 4.
 Start $\frac{1}{4}$ " from the former base.
 $50\frac{1}{2}$ turns clockwise of 36 S.W.G. wire, D.F.C.
 Winding Type - Single Wave - 51:54.
 Wound on Douglas Gears - A.50, B.36, C.34,
 D.50, E.60, F.60.
 Finish - Held with one washer.

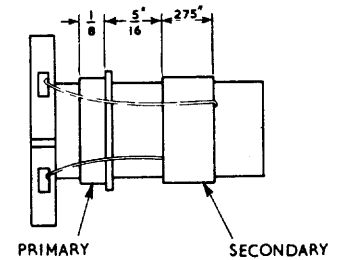

SECONDARY WINDING

Start Tag 2. Finish Tag 1.
 Start $\frac{5}{16}$ " from the Secondary Coil.
 $7\frac{1}{2}$ turns clockwise of 24 S.W.G. enamel wire.
 Winding Type - Solenoid, turns spaced evenly.
 Length of winding - 0.275".
 Finish - Self supporting on tags.
 Distrene Lacquer.

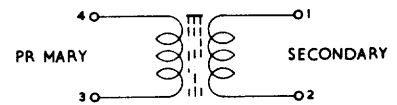

Vacuum impregnated and wax dipped.

Colour Code on Plate:- White, Blue, Blue.

FIG. 41

FIRST R.F. COIL BAND 5 (TR102)

WINDING DATA

PRIMARY WINDING

Start Tag 3. Finish Tag 4.
Start $5/32$ " from the former base.
 $28\frac{1}{2}$ turns anti-clockwise of 41 S.W.G. wire, D.F.C.
Winding Type - Close wound solenoid.
Length of winding - $3/16$ ".
Finish - Held with one washer.

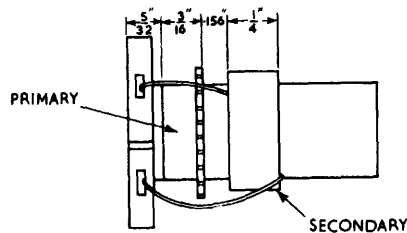

SECONDARY WINDING

Start Tag 2. Finish Tag 1.
Start 0.156 " from the Primary Coil.
 $3\frac{1}{2}$ turns anti-clockwise. Turns spaced evenly,
of 20 S.W.G. enamel wire.
Winding Type - solenoid.
Length of winding - 0.25 ".
Finish - Self supporting on tags.
Distrene Lacquer.

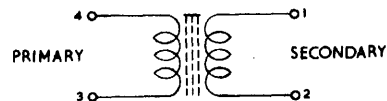

Vacuum impregnated and wax dipped.

Colour code on Plate:- White, white, Blue.

FIG. 42

SECOND R.F. COIL BAND 1 (TR103)

WINDING DATA

PRIMARY WINDING (Wound after Secondary)

Start Tag 2. Finish Tag 3.
 Start $2\frac{3}{32}$ " from the former base.
 $2\frac{1}{4}$ turns anti-clockwise of 38 S.W.G. wire, D.F.C.
 Winding Type - Solenoid.
 Wound just above the finishing washer of the
 Secondary Winding.
 Finish - At washer holding the finish of the
 Secondary Winding.

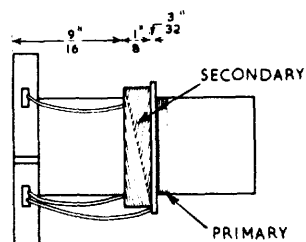

SECONDARY WINDING

Start Tag 2. Finish Tag 1.
 $87\frac{1}{4}$ turns clockwise of $\frac{3}{42}$ S.W.G. wire, D.F.C.
 Winding Type - Single Wave 51:54.
 Wound on Douglas Gears - A.50, B.36, C.34,
 D.50, E.60, F.60.
 Length of Winding - $\frac{1}{8}$ ".
 Finish - Washer.
 Distrene Lacquer.

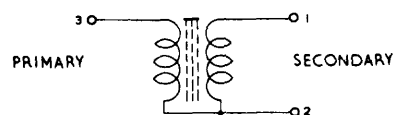

Vacuum impregnated and wax dipped.

Colour Code on Plate:- Blue, Red, Blue.

SECOND R.F. COIL BAND 2 (TR103)

WINDING DATA

PRIMARY WINDING (Wound after Secondary)

Start Tag 2. Finish Tag 3.
 2½ turns anti-clockwise of 38 S.W.G. wire, D.F.C.
 Winding Type - Solenoid.
 Wound on top of the Secondary Winding, at the
 end nearest to the base of the former.
 Finish - Washer holding the start of the
 Secondary Winding.

SECONDARY WINDING

Start Tag 2. Finish Tag 1.
 Start ½" from the former base.
 38½ turns anti-clockwise of 38 S.W.G. wire,
 enamel D.F.C.
 Winding Type - Close wound solenoid.

Vacuum impregnated and wax dipped.

Colour Code on Plate:- Blue, Yellow, Blue.

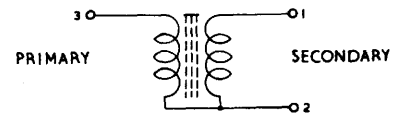
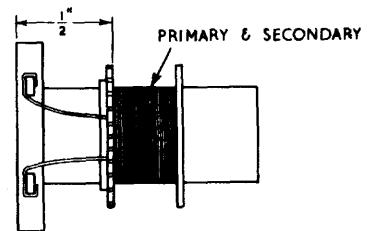

FIG. 44

SECOND R.F. COIL BAND 3 (TR103)

WINDING DATA

PRIMARY WINDING (Wound after Secondary)

Start Tag 2. Finish Tag 3.
 Start 9/16" from the former base.
 2½ turns anti-clockwise of 38 S.W.G.
 wire, D.F.C.
 Winding Type - solenoid, wound on top of the
 Secondary winding at the end nearest to the
 former base.
 Finish - Washer holding the start of the
 Secondary winding.

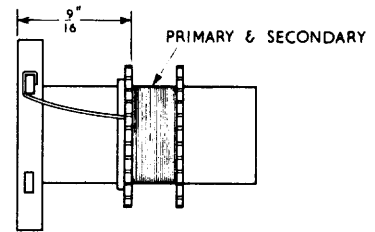

SECONDARY WINDING

Start Tag 2. Finish Tag 1.
 Start 9/16" from the former base.
 13½ turns anti-clockwise of 32 S.W.G.
 wire, D.F.C.
 Winding Type - Close wound solenoid.
 Finish - start and finish at the washers.
 Distrene Lacquer.

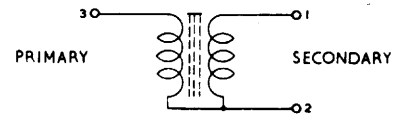

Vacuum impregnated and wax dipped.

Colour Code on Plate:- Blue, Green, Blue.

SECOND R.F. COIL BAND 4 (TR103)

WINDING DATA

PRIMARY WINDING (Wound after Secondary)

Start Tag 2. Finish Tag 3.
 Start $19/32$ " from the former base.
 $2\frac{1}{2}$ turns clockwise of 38 S.W.G. wire D.F.C.
 Winding Type - Solenoid, interwound with the
 Secondary Winding at the end nearest to the
 base of the former.
 Finish - Ends held with 0.005 " x $\frac{1}{4}$ " Lassothy Tape.

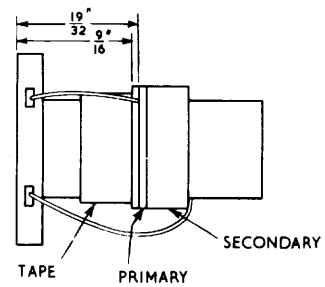

SECONDARY WINDING

Start Tag 2. Finish Tag 1.
 Start $9/16$ " from the former base.
 $7\frac{1}{2}$ turns clockwise of 24 S.W.G. enamel wire.
 Winding Type - solenoid with the turns
 spaced evenly.
 Length of Winding 0.275 ".
 Finish - Self supporting on tags.

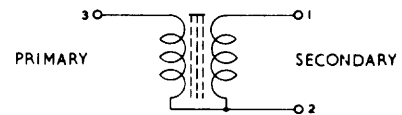

Vacuum impregnated and waxed dipped.

Colour Code on Plate:- Blue, Blue, Blue.

FIG. 46

SECOND R.F. COIL BAND 5 (TR103)

WINDING DATA

WINDING

Start Tag 2. Finish Tag 1.
Start 5/8" from the former base.
32 turns of 20 S.W.G. enamel wire.
Winding Type - Solenoid with evenly spaced turns.
Length of Winding - 0.29"
Finish - Self supporting on tags.

Vacuum impregnated and wax dipped.

Colour Code on Plate:- Blue, White, Blue.

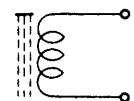
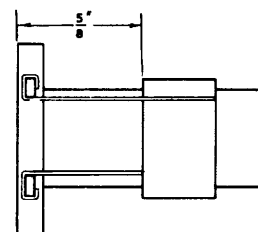

FIG. 47

OSCILLATOR COIL BAND 1 (L102)

WINDING DATA

WINDING

Start Tag 1. Finish Tag 2.

All turns wound anti-clockwise of

40 S.W.G. enamel wire

Start $\frac{3}{8}$ " from the base of the former.

$30\frac{1}{2}$ turns to Tap 1, Tag 3.

$52\frac{1}{2}$ turns to Tap 2, Tag 4.

$74\frac{1}{2}$ turns, finish at Tag 2.

Winding Type - Close wound solenoid.

Finish - Four washers, on each at the start and finish and one at each tap.

Distrene Lacquer.

Vacuum impregnated and wax dipped.

Colour Code on Plate:- Green, Red, Blue.

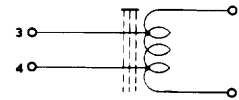
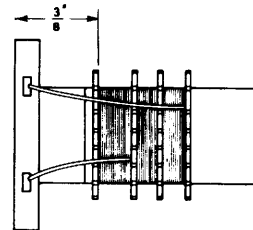

FIG. 48

OSCILLATOR COIL BAND 2 (L102)

WINDING DATA

WINDING

Start Tag 1. Finish Tag 2.

All turns are wound anti-clockwise
of 38 S.W.G. wire.

Start $\frac{1}{2}$ " from the base of the former.

$6\frac{1}{2}$ turns to Tap 1, Tag 3.

$18\frac{1}{2}$ turns to Tap 2, Tag 4.

$31\frac{1}{2}$ turns, Finish Tag 2.

Winding Type - Close wound solenoid.

Finish - Four washers, one each at the
start and finish and one at each of the taps.

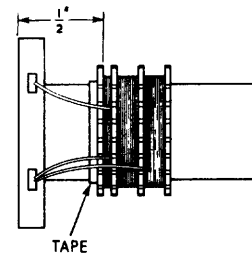

Vacuum impregnated and wax dipped.

Colour Code on Plate:- Green, Yellow, Blue.

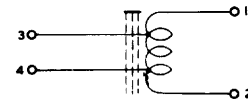

OSCILLATOR COIL BAND 3 (L102)

WINDING DATA

AUXILIARY WINDING

Start Tag 3. Finish Tag 1.
 $\frac{1}{2}$ turn anti-clockwise of 23 S.W.G. wire T/C.
 Winding Type - Link.
 Finish - wire taut, solder to the tags.

MAIN WINDING

Start Tag 1. Finish Tag 2.
 Start $\frac{9}{16}$ " from the base of the former.
 All turns anti-clockwise of 34 S.W.G. wire
 enamel and S.F.C.
 $5\frac{1}{2}$ turns Tap 1, Tag 4.
 $13\frac{1}{2}$ turns, finish Tag 2.
 Winding Type - Close wound solenoid.
 Finish - Three washers, one at start,
 one at tap and one at finish.
 Distrene Lacquer.

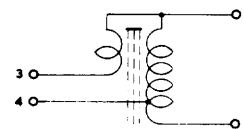
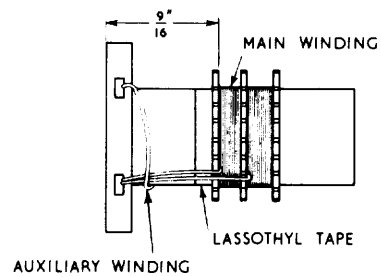

Vacuum impregnated and wax dipped.

Colour Code on Plate:- Green, Green, Blue.

FIG. 50

OSCILLATOR COIL BAND 4 (L102)

WINDING DATA

AUXILLIARY WINDING (Wound First)

Start Tag 3. Finish Tag 1.
Start $\frac{5}{32}$ " from the former base.
 $\frac{1}{2}$ turn anti-clockwise, of 23 S.W.G. wire T/C.
Winding Type - Link.
Finish - Taut wire, solder tags.

MAIN WINDING

Start Tag 1. Finish Tag 2.
Start $\frac{5}{8}$ " from the former base.
All turns anti-clockwise of 26 S.W.G. wire
enamel, S.F.C.
 $2\frac{1}{2}$ turns Tap 1, Tag 4.
 $7\frac{1}{2}$ turns, finish Tag 2.
Winding Type - Close wound solenoid.
Finish - Three washers, one at the start,
one at the tap and one at the finish.

Vacuum impregnated and wax dipped.

Colour Code on Plate:- Green, Green, Blue.

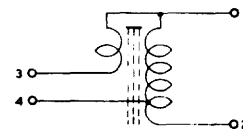
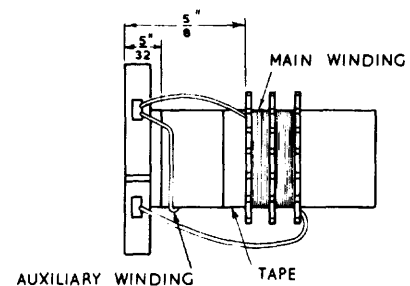

OSCILLATOR COIL BAND 5 (L102)

WINDING DATA

AUXILLIARY WINDING (Wound First)

Start Tag 1. Finish Tag 3.
 Start $\frac{5}{32}$ " from the former base.
 $\frac{1}{2}$ turn anti-clockwise of 23 S.W.G. T/C wire.
 Winding Type - Link.
 Finish - wire taut, and solder to tags.

MAIN WINDING

Start Tag 1. Finish Tag 2.
 Start $\frac{5}{8}$ " from the former base.
 4.95 turns clockwise of 20 S.W.G. enamel wire.
 1.20 turns to Tap 1, Tag 4. The tap is brought out by soldering on 23 S.W.G. T/C wire to the Main winding.
 $3\frac{1}{2}$ turns to the finish at Tag 2.
 Winding Type - Solenoid, with evenly spaced turns.
 Length of winding - 0.290"
 Finish - Self supporting on tags.

Vacuum impregnated and wax dipped.

Colour Code on Plate:- Green, white, Blue.

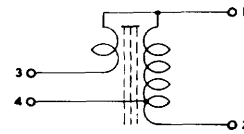
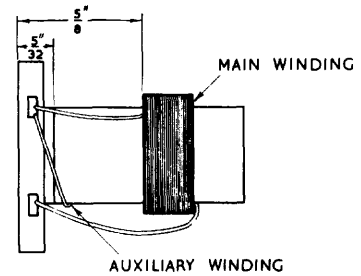

FIGS. 52 & 53

I. F. COILS

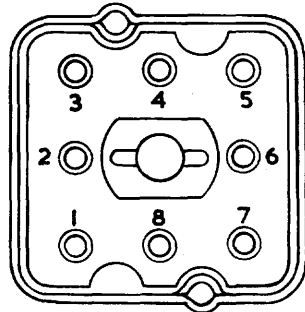

Fig. 52

View of the I.F. Coil Assembly from the base, showing tag positions. Refers to all I.F. Assemblies.

All windings are anchored to washers and securely soldered to the stated spills and tags.

I. F. TRANSFORMER TR104

WINDING DATA

PRIMARY WINDING

Start Tag 3. Finish Tag 5.
 11 1/2 turns of 30/48 S.W.G. enamel and double fused wire C/A, 0.005 lb weight.
 Two turns of Lassothyl Tape.
 Wound on Douglas Gears, A.50, B.32, C.31, D.50, E.40, F.80.

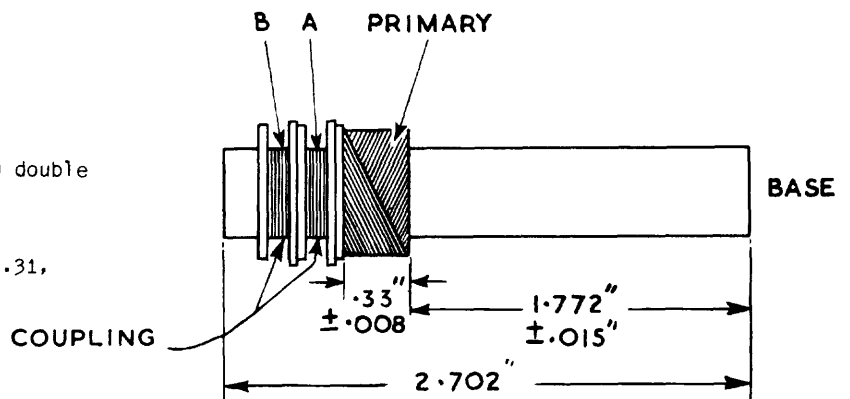

COUPLING COILS

Coil "A" Start Tag 7. Finish Tag 6.
 1 1/2 turns of 40 S.W.G. Eureka enamel wire (0.0001 lb).

Coil "B" Start Tag 1. Finish Tag 4.
 1 1/2 turns of 36 S.W.G. wire, D.F.C. (0.0001 lb).

Finish - wax impregnate and dip

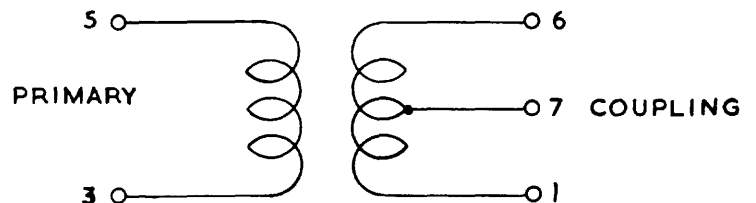

FIG. 54

I.F. INPUT COIL (L201)

WINDING DATA

Start Tag 3. Finish Tag 8.
76½ turns to the tap (Tag 2)
Total Turns - 114½ of 30/48 S.W.G. enamel
and double fused wire (0.005 lb).
Two turns of Lassoethyl Tape.
Wound on Douglas Gears - A.50, B.32, C.31,
D.50, E.40, F.80.

Finish - wax impregnate and dip.

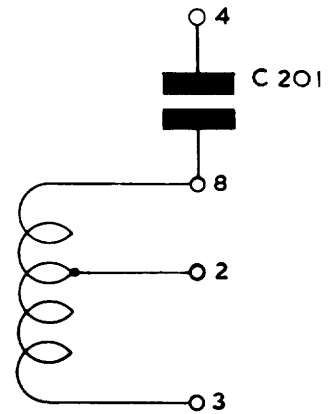
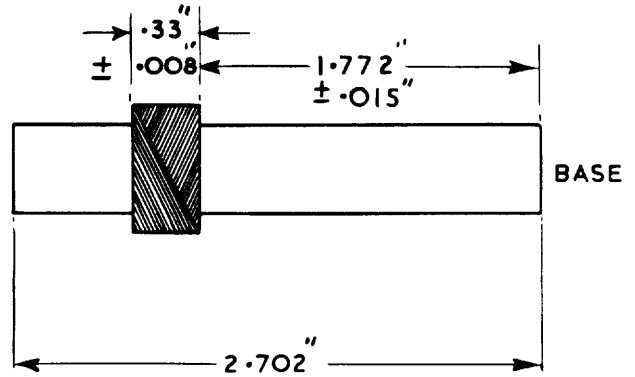

FIG. 55

I. F. TRANSFORMERS (TR201 AND TR202) PATTERNS 57140/A

WINDING DATA

PRIMARY WINDING

Start Tag 5. Finish Tag 7.
 114½ turns of 30/48 S.W.G. enamel and double fused C/A wire (0.005 lb).
 Two turns of Lassothyl Tape.
 Wound on Douglas Gears A.50, B.32, C.31, D.50, E.40, F.80.

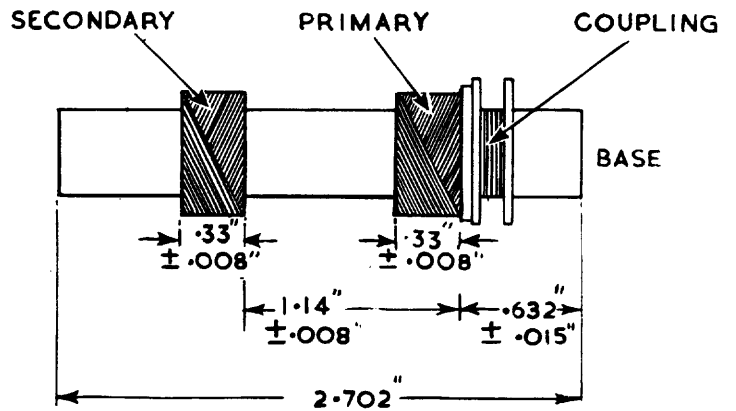

SECONDARY WINDING

Start Tag 8. Finish Tag 3.
 82½ turns to tap (Tag 2).
 Total turns - 114½ of 30/48 S.W.G. and double fused C/A wire.
 Two turns of Lassothyl Tape.
 Wound on Douglas Gears - A.50, B.31, C.31, D.50, E.40, F.80.

COUPLING WINDING

Start Tag 3. Finish Tag 1.
 1½ turns of 40 S.W.G. Eureka enamel wire (0.0001 lb).

Finish wax impregnation and Dip.

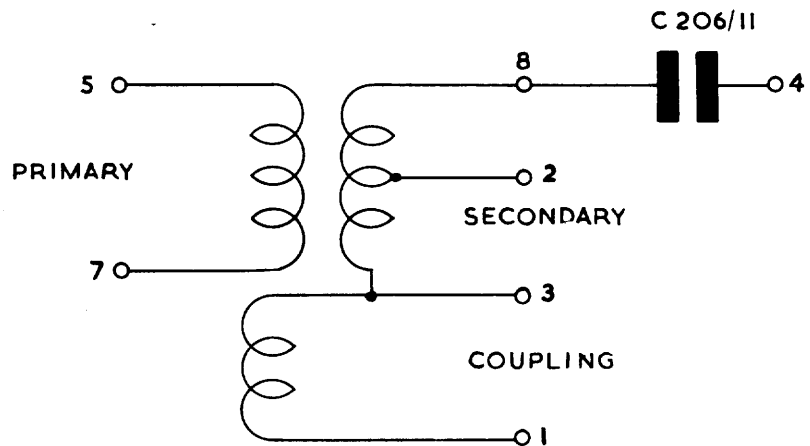

FIG. 56

I. F. TRANSFORMERS (TR201 AND TR202)

PATTERNS 57140B/C/D

WINDING DATA

PRIMARY WINDING

Start Tag 5. Finish Tag 7.
 114½ turns of 30/48 S.W.G. enamel and
 double fused C/A wire (0.005 lb).
 Two turns of Lassothyl Tape.
 Wound on Douglas Gears - A.50, B.32, C.31,
 D.50, E.40, F.80.

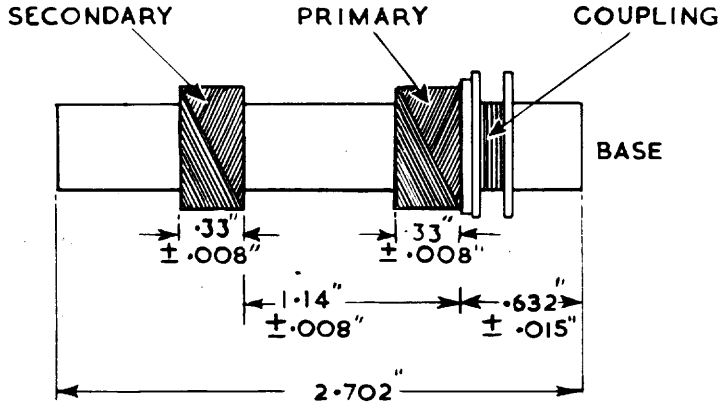

SECONDARY WINDING

Start Tag 8. Finish Tag 3.
 82½ turns to tap (Tag 2).
 Total turns - 114½ of 30/48 S.W.G. enamel
 and double fused C/A wire (0.005 lb).
 Wound on Douglas Gears - A.50, B.32, C.31,
 D.50, E.40, F.80.
 Two turns of Lassothyl Tape.

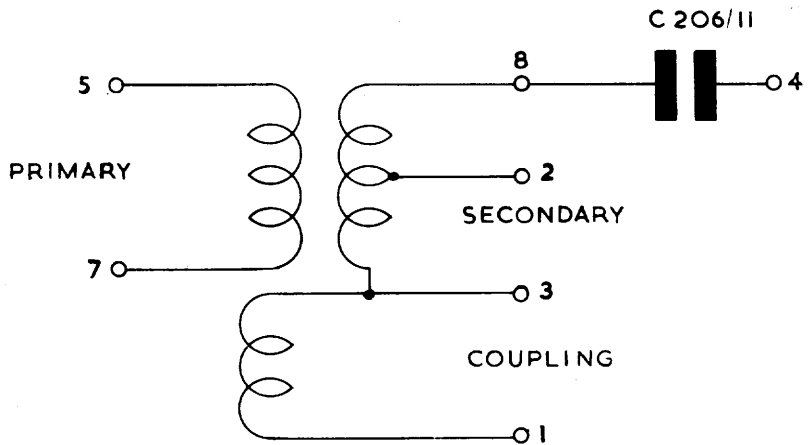

COUPLING WINDING

Start Tag 3. Finish Tag 1.
 3½ turns of 40 S.W.G. Eureka enamel
 wire (0.0001 lb).

Finish - Wax impregnate and dip

FIG. 57

I. F. TRANSFORMER (TR203)

WINDING DATA

PRIMARY WINDING

Start Tag 5. Finish Tag 7.
 117½ turns of 30/48 S.W.G. enamel and
 double fused C/A wire (0.005 lb)
 Two turns of Lassoethyl Tape.
 Wound on Douglas Gears - A.50, B.32,
 C.31, D.50, E.40, F.80.

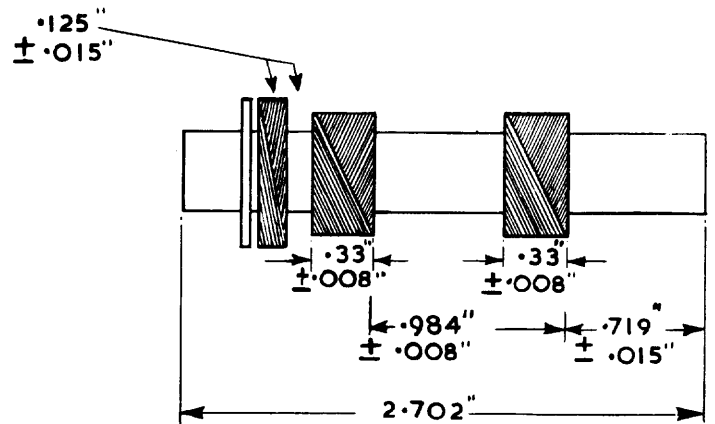

SECONDARY WINDING

Start Tag 1. Finish Tag 3.
 117½ turns of 30/48 S.W.G. enamel and
 double fused C/A wire (0.005 lb)
 Two turns of Lassoethyl Tape.
 Wound on Douglas Gears A.50, B.32, C.31,
 D.50, E.40, F.80.

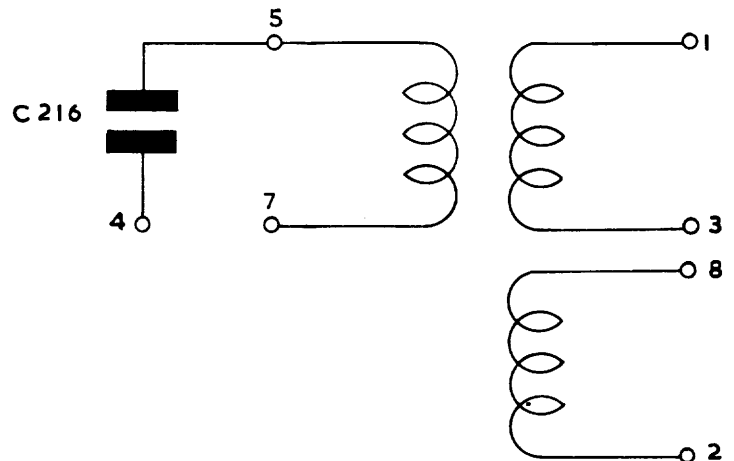

B.F.O. COUPLING WINDING

Start Tag 2. Finish Tag 8.
 99½ turns of 36 S.W.G. wire D.F.C. (0.003 lb).
 Two turns of Lassoethyl Tape.
 Wound on Douglas Gears - A.50, B.36, C.34,
 D.50, E.60, F.60.

Finish - wax impregnate and dip.

FIG. 58

BEAT FREQUENCY OSCILLATOR COILS (L202 AND L205)

WINDING DATA

L202

Start Tag 3. Finish Tag 5.
 49½ turns to tap (Tag 7).
 Total turns 99½ of 30/48 S.W.G. enamel and
 D.F.C.A. wire (0.004 lb).
 Two turns of Lassothyl Tape.
 Wound on Douglas Gears - A.50, B.32, C.31,
 D.50, E.40, F.80.

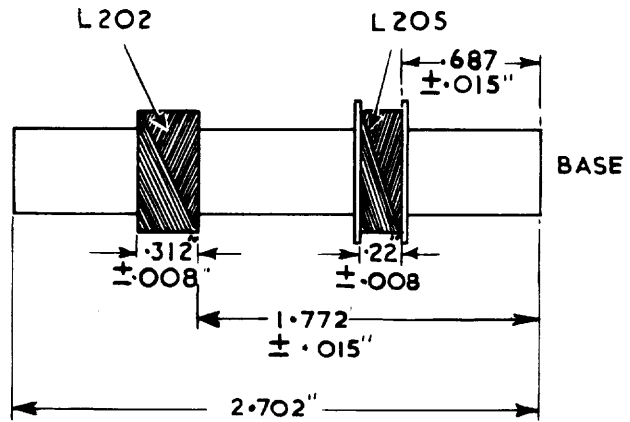

L205

Start Tag 5. Finish Tag 6.
 12½ turns of 26 S.W.G. enamel and S.F.C.
 wire (0.002 lb).
 Two turns of Lassothyl Tape.
 Single layer winding.

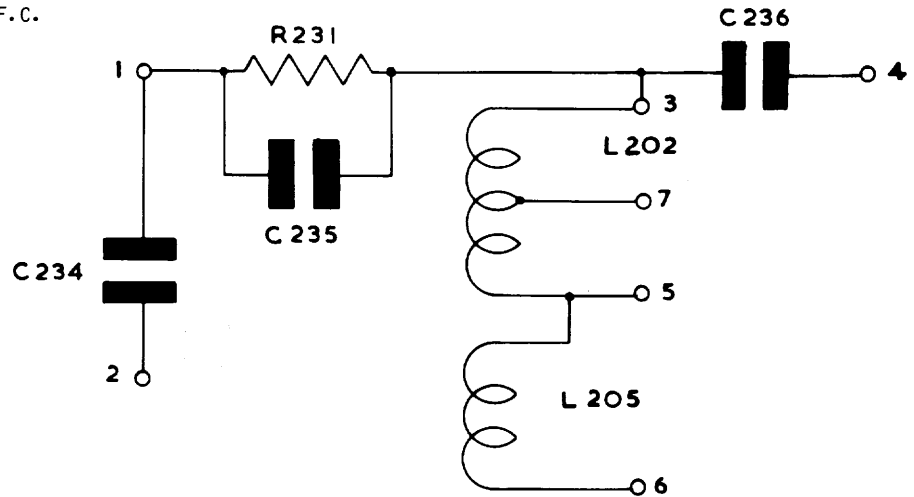

Finish - wax impregnate and dip.

FIG. 59

PITCH COILS (L203 AND L204)

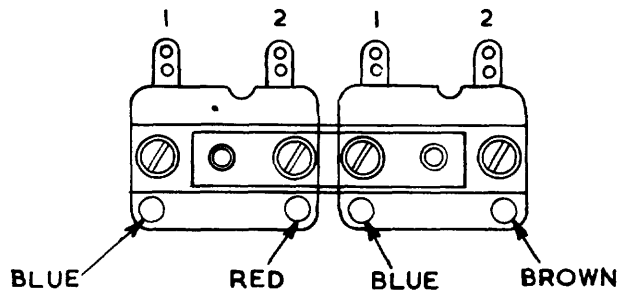
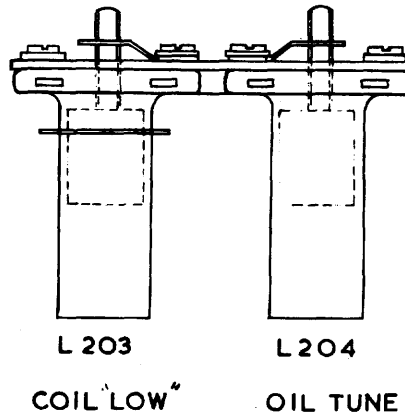

WINDING DATA

COIL LOW (L203)

10½ turns of 26 S.W.G. enamel C.U. wire.
Start Tag 2 (Near shoulder of the former)
Finish Tag 1.

COIL TUNE (L204)

7½ turns of 24 S.W.G. enamel C.U. wire.
Start Tag 2 (Near shoulder of the former)
Finish Tag 1.

NOTE

When winding the rotation of both formers is clockwise looking from the top.

Vacuum impregnate and wax dip

FIG. 60

CHOKE R.F. (L101)

1.5 mH

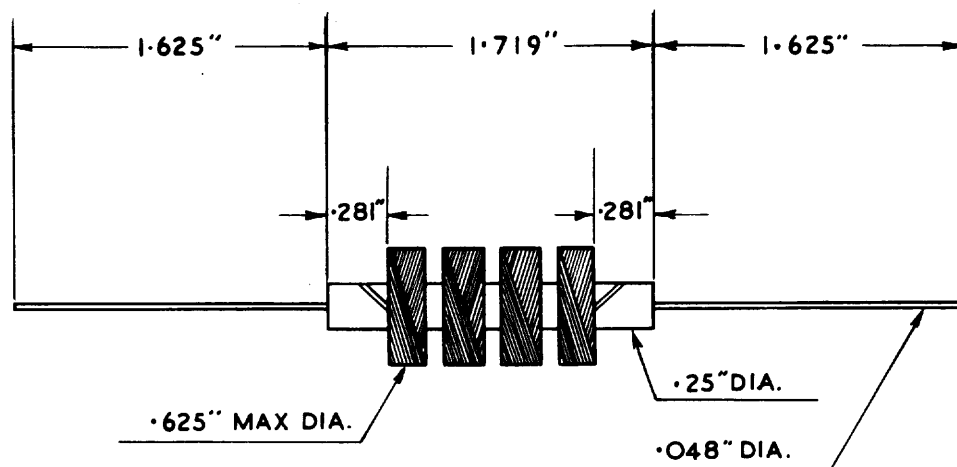

WINDING This may be split into four or five sections.

INDUCTANCE 1.5 millihenries \pm 10%.

D.C. RESISTANCE 10% ohms \pm 25%.

FIG. 61

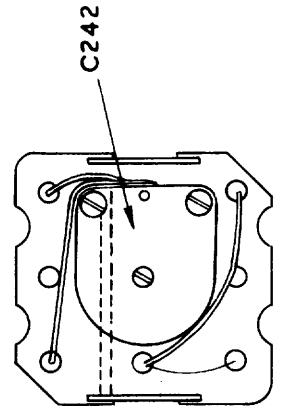
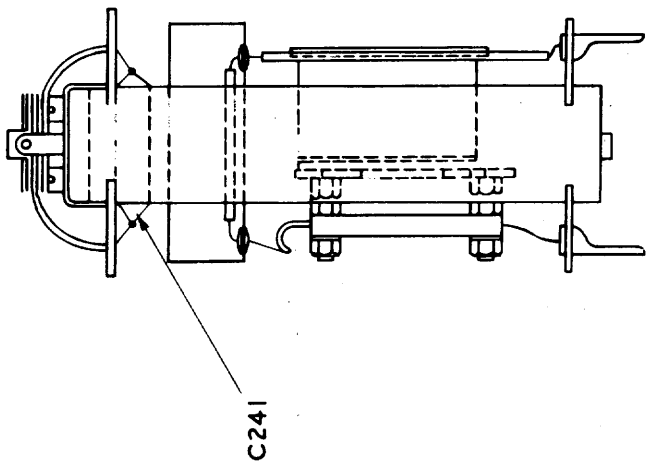
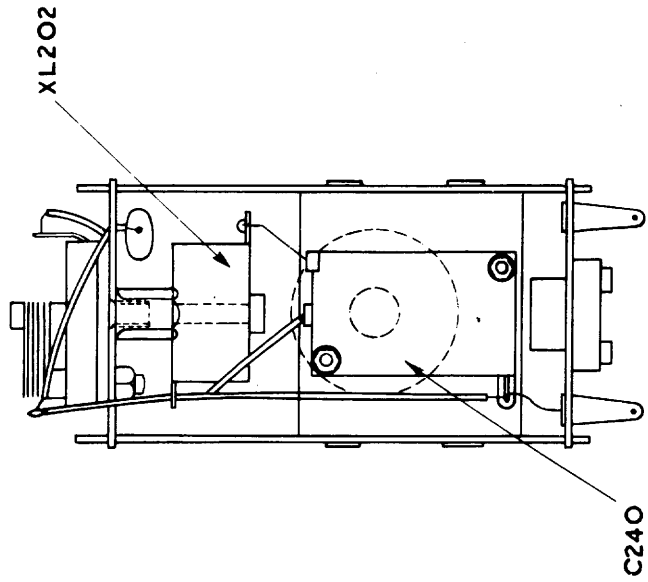
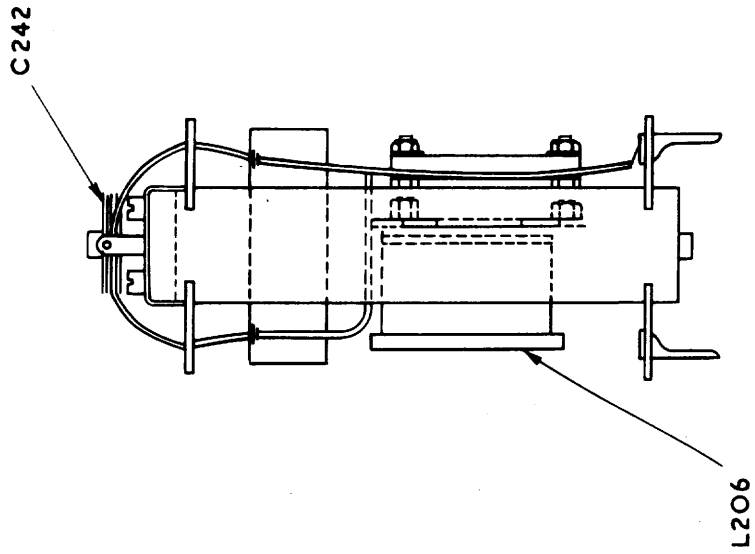

Crystal Filter Assembly Details
Patterns 57140B/C/D

FIG. 62

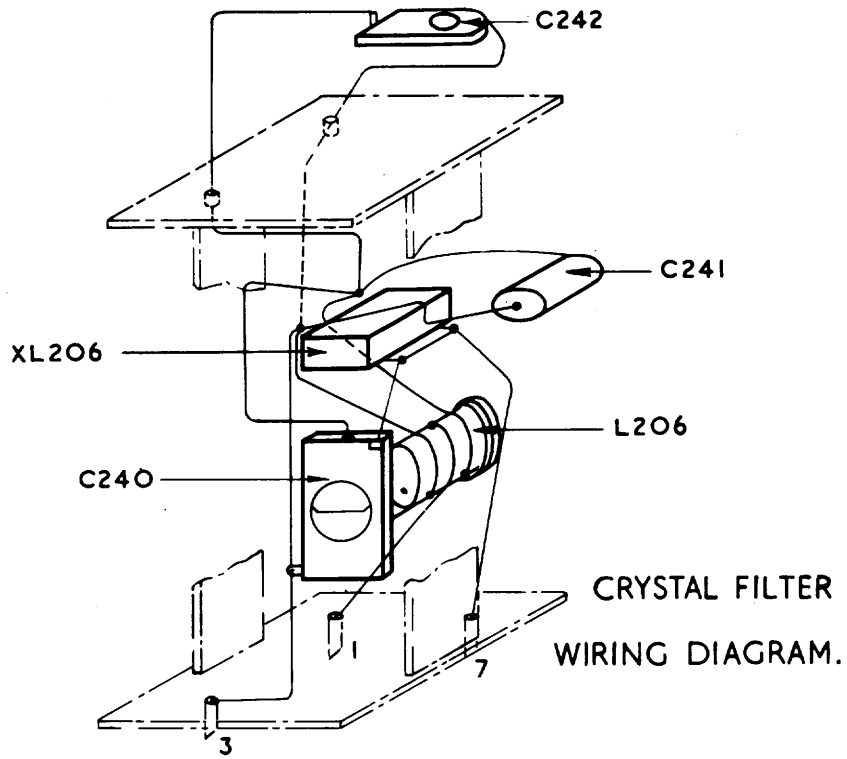
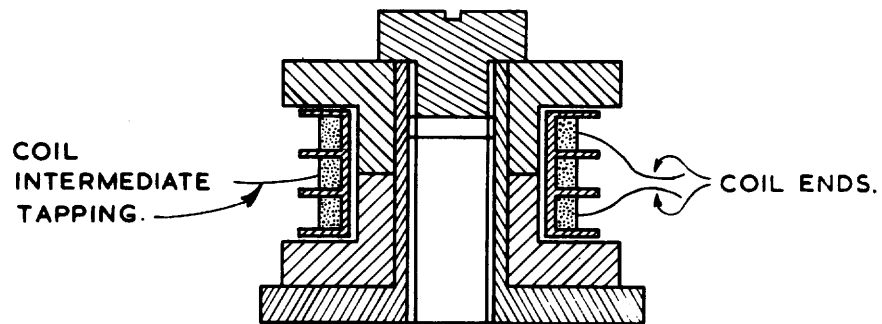

FIG. 63



CRYSTAL FILTER COIL (L206)

Patterns 57140B/C/D

WINDING DATA

183 turns 30/48 Litz wire; sectionalised thus:—

1st Section	61 turns.
	30½ turns to tap lead.
2nd Section	Tap lead to be 2" long.
	30½ turns to finish.
3rd Section	61 turns.

Secured with Chattertons Compound.

Leave the ends two inches long, tinned for about 1½" of their length.

Start lead has Red 2 m/m art silk sleeving.

Finish lead has white 2 m/m art silk sleeving.

Wind the bobbin and dip in Messrs Campbells LPRM.3 wax.

When reassembled to be tested electrically and then dipped in Messrs Campbells LPRM.3 wax, and Messrs Berry Wiggins Compound 1202.

FIG. 64

NOTE FILTER (L301)
PATTERNS 57140/A

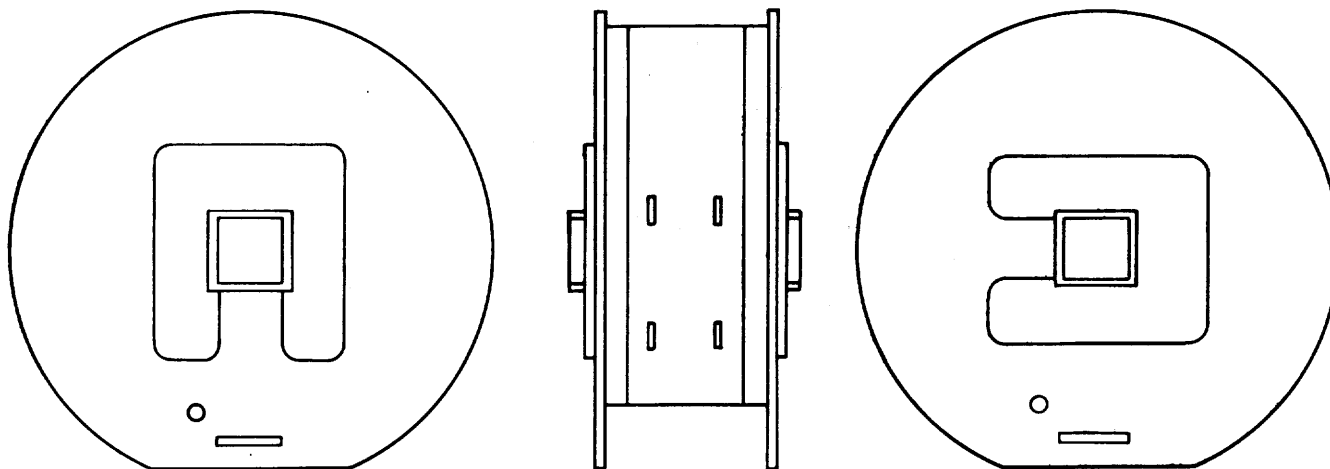

WINDING DATA

6,800 turns of enamel copper wire, 36 S.W.G. (0.0076"), the ends looped and twisted into three way cable for the lead outs and sleeved with 1 m/m silk sleeving.

The two tag panel and becking piece is fixed by means of two turns of white tape 7/8" wide, secured by Chattertons compound where the tape is cut off. The tags are pushed through holes in the tape. Alternatively 1/2" wide tape can be used, half lapped and secured in the same manner employing one layer.

The lead outs are soldered to the tags above the tape, they are anchored by 1/4" adhesive tape and insulated from the windings by 0.002" x 0.75" paper.

The inductance is adjusted to 10% of standard by moving the core. This is fixed with adhesive and the coil impregnated.

D.C. Resistance - 390 ohms.

Q - 18.5.

Inductance - 1 Henry.

IRON CORED TRANSFORMERS AND CHOKESDATA

As these components are not considered repairable, the information given is limited to that necessary to provide a suitable substitute for emergency use.

1. Choke A.P. 65560

Circuit Reference - L302
Fitted to all patterns of the receiver.

Inductance - 25 Henrys at 7 mA d.c.
- 18 Henrys at 20 mA d.c.

D.C. Resistance - 690 ohms

Distance between fixing centres - $1\frac{25}{32}$ in.

Tags (a and b) - See Figs. 18, 21 and 23.

2. Choke A.P. 65564

Circuit Reference - L303.
Fitted on Patterns 57140/A only.

Inductance - 10 Henrys at 100 mA D.C.

D.C. Resistance - 260 ohms $\pm 10\%$

Distance between fixing centres - $\frac{21}{8}$ in. x $1\frac{3}{4}$ in. $\pm \frac{3}{16}$ in.

3. Choke A.P. 67762

Circuit Reference - L304.
Fitted on Patterns 57140B/C/D only.

Inductance - 20 Henrys at 100 mA d.c.

Distance between fixing centres - 2 in. x $\frac{31}{8}$ in.

D.C. Resistance 325 ohms.

4. Output Transformer A.P. 65689

Circuit Reference - TR301
Fitted to all patterns of the receiver.

Primary Inductance - 5.6 Henrys at 10V 50 c/s and 40 mA d.c.

D.C. Resistance - Primary	- 240 ohms	2,200 Turns
Secondary 1.	IS/TS - 61 ohms	650 "
	OS/TS) - 1.67 ohms	62 "
Secondary 2.	(On side) - 4.9 ohms	69 "

7. Mains Transformer A.P.67763A (C Core)

Circuit Reference TR302.
Fitted to Patterns 57140B/C/D only.

Primary Winding

Voltage - Common	115	230	Volts	40/60 c/s a.c.
D.C. Resistance	20		Ohms	over-all.

Secondary Winding

Voltage	276-0-276	Volts	
Current	80	Milliamps	
D.C. Resistance	320	Ohms	overall.

Heater Winding

Voltage	6.4	Volts
Current	4	Amps.
D.C. Resistance	less than 0.5	Ohms

Rectifier Heater Winding

Voltage	6.4	Volts
Current	0.9	Amps.
D.C. Resistance	less than 0.75	Ohms.

Tags - See Figs. 21 and 23.

FIG. 65

R	101	103	104	105	106	108	109	110	111	112	113	114	116	117	118	120	R	
C	101	102	103	104	105	106	107	108	109	110	111	112	113	114	115	116	117	C
MISC	PL101	RV102	SW101	V101	TR102	L102	SW102b	XL101	SW102c	L101	SW102d	SK101	PL103	MISC				MISC

R.F. UNIT

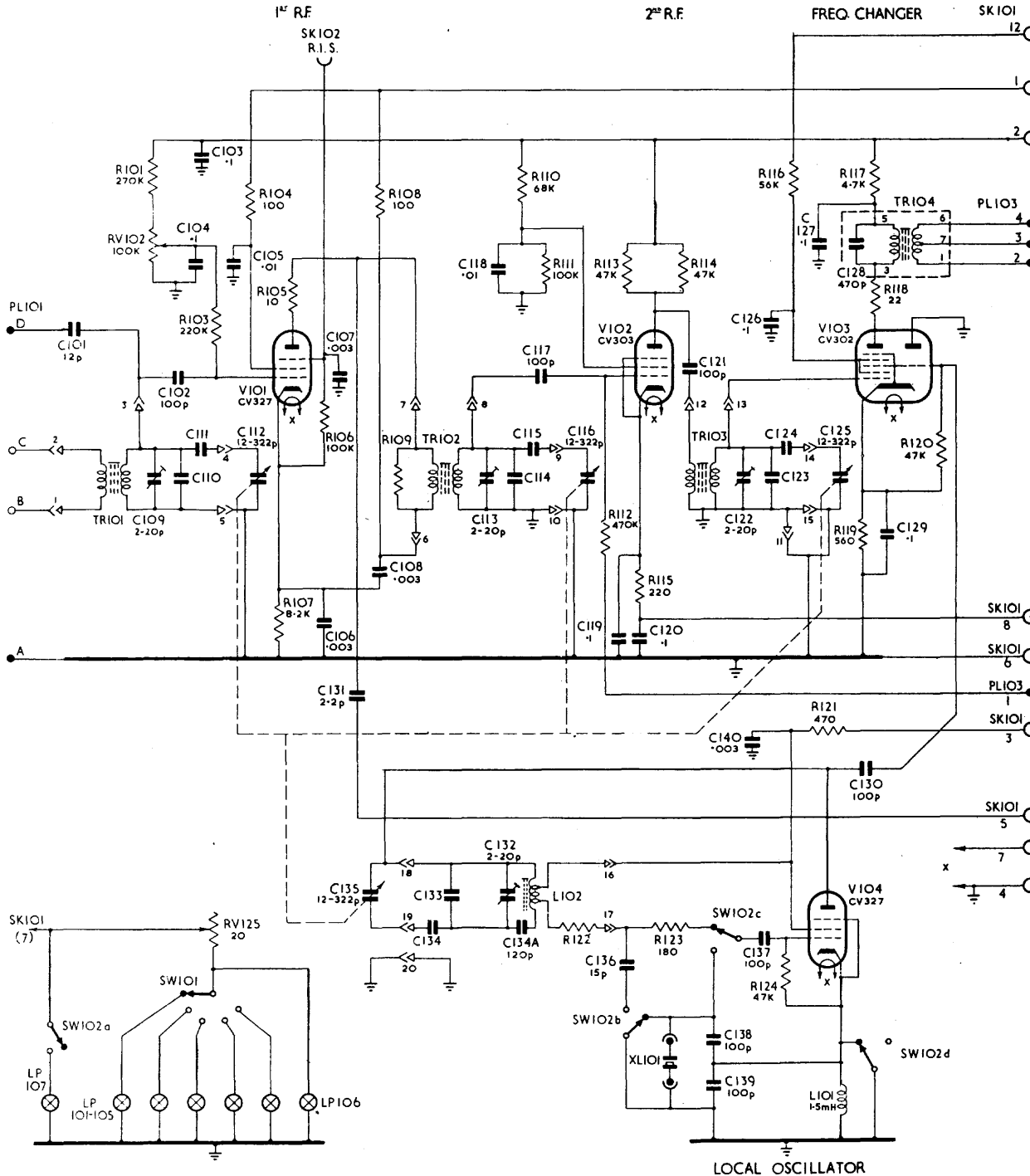

NOTE:- REFER TO COMPONENTS LIST FOR VALUES OF COMPONENTS IN TURRET COMPARTMENTS.

209 210a 210b	212 213	231 235	236 229	211 237	232 230	221 222	219 223	225 226	301 310	312 302 304	311 303	314 306	307 308	313 308	R
232 237	217 233	216 234 235	215 214 235	214 236	230	226 224 228	227 229 231	225	230	306 318	303	315 319	316 317 313 314	309 310	C
V203 XL201 L203	V204a SK202 L202 L204 L205	TR203 V206 L202 SW202n	V205 SW203 SW202f	V204b SW206c SW206b	RV220 LS	RV224 SK203	PL204 SK301 RV305	V304 V301 TR204	L302 L304 SW205	V303 V302 TR301	RV309 FS301 TR302	SK302 FS302	SW301 PL301 FS303	MISC	

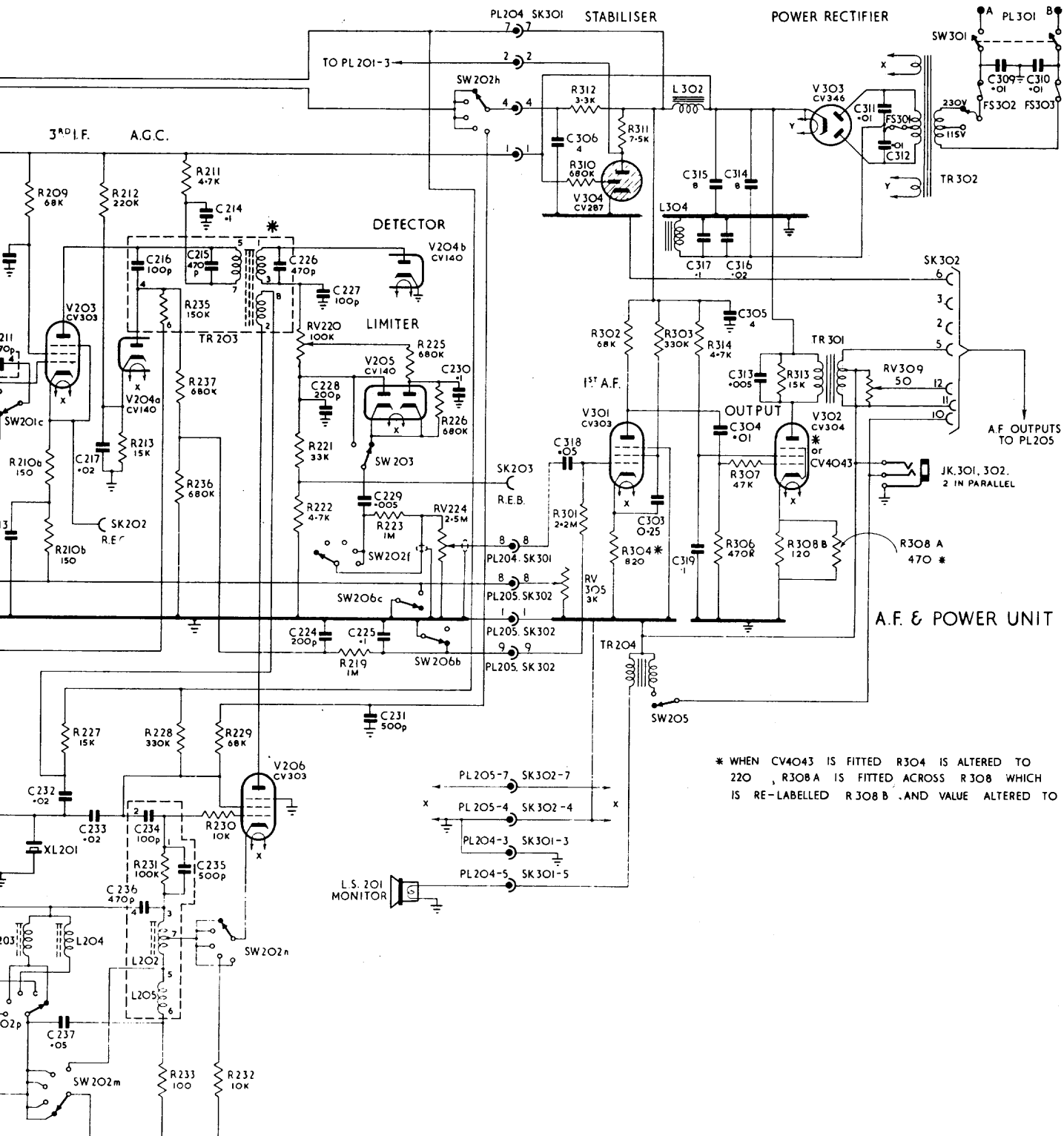

* WHEN CV403 IS FITTED R304 IS ALTERED TO 220, R308A IS FITTED ACROSS R308 WHICH IS RE-LABELLED R308B AND VALUE ALTERED TO 470

RECEIVER 62B. A.P. 67757
CIRCUIT DIAGRAM.

R	201 202 203 234 218				204		206 205 207				208		209 210a 210b		212 213		231 236 211 232 235 229		237 230		
C	229	201 239	223 238	202 203	205 204	206	240	241	242	222	221	207 208	209 210	218 211	212 213	232 237	217 233	216 234 236	215 214		
MISC	SW201a PL201 SK201	L201 TL	V201 TR205 PL203	TR201 SW206a	SW201b SW206d PL205	SW201f SW201j	XL202	SW201g SW201h SW202j L206	V202	TR202	SW201c SW202k,m,p,q	V203 XL201 L203 L204	SK202	V204a L202 L205	TR203	V206 SW202n					

I.F. UNIT

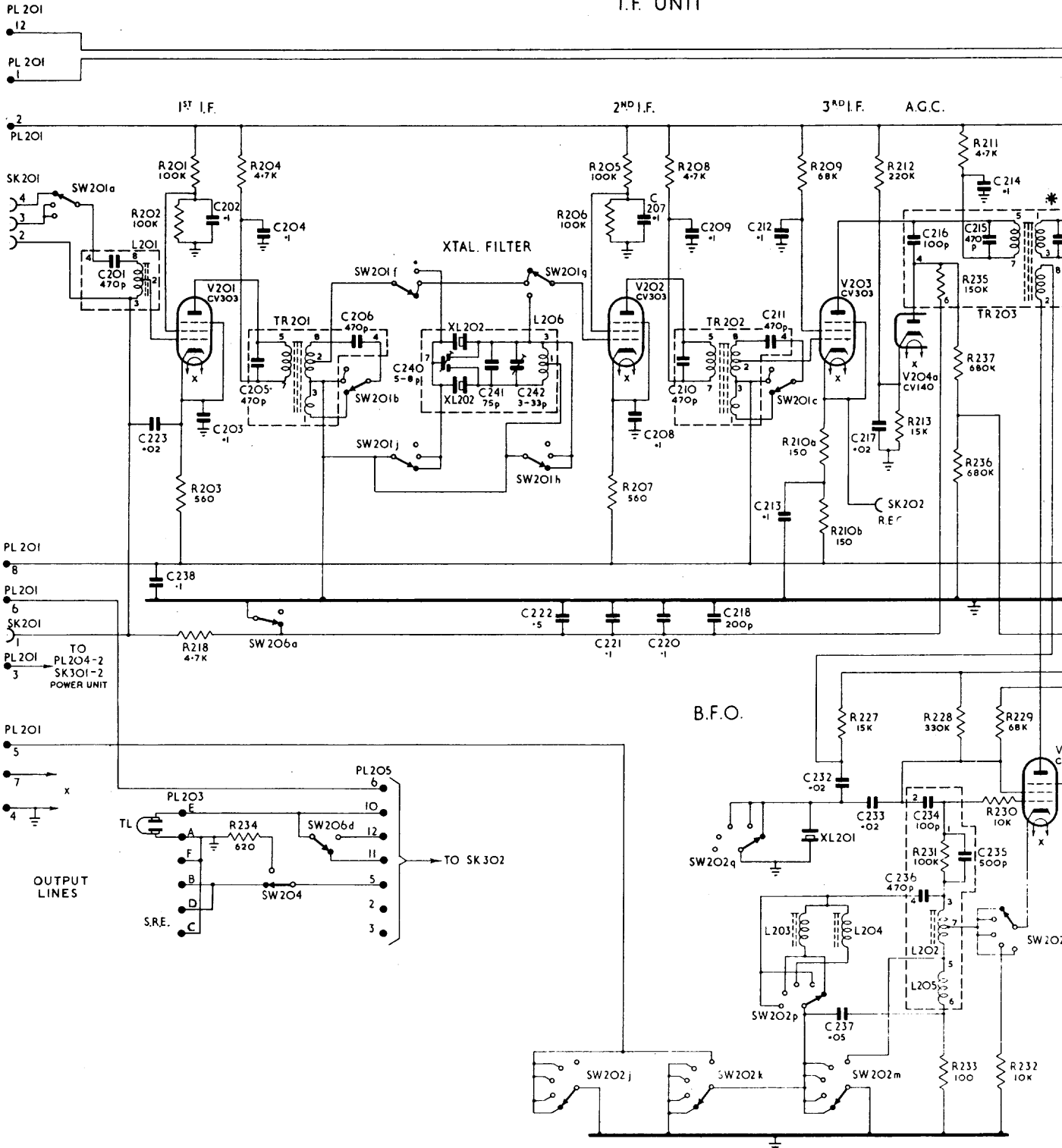

COMPONENTS LIST RECEIVER 62B PATTERNS 67757

CAPACITORS

Ref.	A.P. or Joint Service Cat. No.	Value	Tol.	Rating	Remarks
C101	Z131175	12 pF	10%	500V	
C102	Z123194	100 pF	20%	350V	
C103	Z115095	0.1 μF	20%	350V	
C104	Z115095	0.1 μF	20%	350V	
C105	Z124407	0.01 μF	20%	350V	
C106	Z124477	0.003 μF	20%	350V	
C107	Z124477	0.003 μF	20%	350V	
C108	Z124477	0.003 μF	20%	350V	
C109	≠ AP. 52437	2-20 pF	10%		Variable
C110	Z131191	39 pF	5%	500V	Band 1
C110	Z131178	15 pF	10%	500V	Band 4
C110	Z131194	47 pF	5%	500V	Band 5
C111	Z125666	600 pF	5%	350V	Band 4
C111	Z125664	450 pF	5%	350V	Band 5
C112	AP. 60189	12-322 pF			Ganged Capacitor Section
C113	≠ AP. 52437	2-20 pF	10%		Variable
C114	Z131191	39 pF	5%	500V	Band 1
C114	Z131169	6.8 pF	10%	500V	Band 2
C114	Z131058	10 pF	10%	500V	Band 3
C114	Z131186	27 pF	10%	500V	Band 4
C114	Z131197	56 pF	5%	500V	Band 5
C115	Z125666	600 pF	5%	350V	Band 4
C115	Z125664	450 pF	5%	350V	Band 5
C116	AP. 60189	12-322 pF			Ganged Capacitor Section
C117	Z123194	100 pF	20%	350V	
C118	Z124407	0.01 μF	20%	350V	
C119	Z115095	0.1 μF	20%	350V	
C120	Z115095	0.1 μF	20%	350V	
C121	Z123194	100 pF	20%	350V	
C122	≠ AP. 52437	2-20 pF	10%		Variable
C123	Z131191	39 pF	5%	500V	Band 1
C123	Z131169	6.8 pF	10%	500V	Band 2
C123	Z131058	10 pF	10%	500V	Band 3
C123	Z131184	22 pF	10%	500V	Band 4
C123	Z131194	47 pF	10%	500V	Band 5
C124	Z125664	450 pF	5%	350V	Band 5
C124	Z125666	600 pF	5%	350V	Band 4
C125	AP. 60189	12-322 pF			Ganged Capacitor Section
C126	Z115095	0.1 μF	20%	350V	
C127	Z115095	0.1 μF	20%	350V	

≠ Replacement component to be Z160009

CAPACITORS (Continued)

Ref.	A.P. or Joint Service Cat. No.	Value	Tol.	Rating	Remarks
C128	Z125665	470 pF	5%	350V	Cal. Input Variable
C129	Z115095	0.1 μ F	20%	350V	
C130	Z131206	100 pF	10%	500V	
C131	Z131165	2.2 pF	0.5 pF	500V	
C132	≡ AP.52437	2-20 pF	10%	500V	
C133	Z131140	68 pF	5%	500V	
C133	Z131184	22 pF	10%	500V	Band 2
C133	Z132244	12 pF	10%	500V	Band 3
C133	Z132276	22 pF	5%	350V	Band 4
C133	Z125608	33 pF	5%	500V	Band 5
C133A		Not fitted			Band 1
C133A		Not fitted			Band 2
C133A	Z132268	6.8 pF	10%	500V	Band 3
C133A	Z125704	10 pF	5%	500V	Band 4
C133A	Z132279	27 pF	5%	350V	Band 5
C134	Z125476	470 pF	5%	350V	Band 1
C134A	Z125270	120 pF	5%	350V	Band 1
C134	Z125448	390 pF	2%	350V	Band 2
C134	Z126351	2200 pF	10%	350V	Band 3
C134	W6424	500 pF	5%	350V	Band 4
C134	Z125450	390 pF	5%	350V	Band 5
C135	60189	12-322 pF			Ganged Cap. Sect.
C136	Z131178	15 pF	10%	500V	
C137	Z131206	100 pF	10%	350V	
C138	Z123194	100 pF	20%	350V	
C139	Z123194	100 pF	20%	350V	
C140	Z124477	0.003 μ F	20%	350V	
C201	Z125665	470 pF	5%	350V	
C202	Z115506	0.1 μ F	20%	350V	
C203	Z115095	0.1 μ F	20%	350V	
C204	Z115095	0.1 μ F	20%	350V	
C205	Z125665	470 pF	5%	350V	
C206	Z125665	470 pF	5%	350V	
C207	Z115095	0.1 μ F	20%	350V	
C208	Z115095	0.1 μ F	20%	350V	
C209	Z115095	0.1 μ F	20%	350V	
C210	Z125665	470 pF	5%	350V	
C211	Z125665	470 pF	5%	350V	
C212	Z115095	0.1 μ F	20%	350V	
C213	Z115095	0.1 μ F	20%	350V	

≡ Replacement component Z160009

CAPACITORS (Continued)

Ref.	A.P. or Joint Service Cat. No.	Value	Tol.	Rating	Remarks
C214	Z115095	0.1 μ F	20%	350V	
C215	Z125665	470 pF	5%	350V	
C216	Z123194	100 pF	20%	350V	
C217	Z115504	0.02 μ F	20%	750V	
C218	Z123274	200 pF	20%	350V	
C220	Z115095	0.1 μ F	20%	350V	
C221	Z115095	0.1 μ F	20%	350V	
C222	Z115148	0.5 μ F	20%	350V	
C223	Z115504	0.02 μ F	20%	750V	
C224	Z123274	200 pF	20%	350V	
C225	Z115095	0.1 μ F	20%	350V	
C226	Z125665	470 pF	5%	350V	
C227	Z123194	100 pF	20%	350V	
C228	Z123274	200 pF	20%	350V	
C229	Z115502	0.005 μ F	20%	1000V	
C230	Z115095	0.1 μ F	20%	350V	
C231	Z123456	500 pF	20%	350V	
C232	Z115504	0.02 μ F	20%	750V	
C233	Z115504	0.02 μ F	20%	750V	
C234	Z123194	100 pF	20%	350V	
C235	Z123456	500 pF	20%	350V	
C236	Z125665	470 pF	5%	350V	
C237	Z115505	0.05 μ F	20%	500V	
C238	Z115095	0.1 μ F	20%	350V	
C240		5-8 pF			Variable
C241	Z125199	75 pF	2%		Variable
C242		3-33 pF			Variable
C303	Z115565	0.25 μ F	25%	350V	
C304	Z115546	0.01 μ F	20%	500V	
C305	Z112521	4 μ F	20%	400V	
C306	Z112521	4 μ F	20%	400V	
C309	Z124409	0.01 μ F	20%	750V	
C310	Z124409	0.01 μ F	20%	750V	
C311	Z124409	0.01 μ F	20%	750V	
C312	Z124409	0.01 μ F	20%	750V	
C313	Z115502	0.005 μ F	20%	1000V	
C314	Z112934	8 μ F	20%	400V	
C315	Z112934	8 μ F	20%	400V	
C316	Z115516	0.02 μ F	10%	750V	
C317	Z115574	0.1 μ F	10%	350V	
C318	Z115596	0.05 μ F	20%	500V	
C319	Z115632	1 μ F	20%	350V	

RESISTORS

Ref.	A.P. or Joint Service Cat. No.	Value	Tol.	Rating	Remarks	
R101	Z223092	270k ohms	10%	$\frac{1}{2}W$	Variable	
RV102	AP. 51464A	100k ohms		$\frac{1}{4}W$		
R103	Z223080	220k ohms		$\frac{1}{2}W$		
R104	Z221110	100 ohms		$\frac{1}{2}W$		
R105	Z221002	10 ohms		$\frac{1}{2}W$		
R106	Z223038	100k ohms		$\frac{1}{2}W$	Band 1 Band 2	
R107	Z222123	8.2k ohms		$\frac{3}{4}W$		
R108	Z221110	100 ohms		$\frac{1}{2}W$		
R109	Z222005	1k ohm		$\frac{1}{2}W$		
R109	Z222026	1.5k ohms		$\frac{1}{2}W$		
R109	Z222038	1.8k ohms		$\frac{1}{2}W$		Band 3
R109	Z222080	3.9k ohms		$\frac{1}{2}W$		
R110	Z223018	68k ohms		$\frac{3}{4}W$		
R111	Z223038	100k ohms		$\frac{1}{2}W$		
R112	Z223122	470k ohms		$\frac{1}{2}W$		
R113	Z222216	47k ohms		$\frac{3}{4}W$	Band 1 Band 2 Band 3 Band 4	
R114	Z222216	47k ohms		$\frac{3}{4}W$		
R115	Z221152	220 ohms		$\frac{1}{2}W$		
R116	Z223009	56k ohms		$\frac{3}{4}W$		
R117	Z222089	4.7k ohms		$\frac{1}{2}W$		
R118	Z221026	22 ohms		$\frac{1}{2}W$		
R119	Z221206	560 ohms		$\frac{1}{2}W$		
R120	Z222215	47k ohms		$\frac{1}{2}W$	Band 1 Band 2 Band 3 Band 4	
R121	Z221194	470 ohms		$\frac{1}{2}W$		
R122	Z222069	3.3k ohms		$\frac{3}{4}W$		
R122	Z222005	1k ohm		$\frac{3}{4}W$		
R122	Z221143	180 ohms		$\frac{1}{2}W$		
R122	Z221068	47 ohms		$\frac{1}{2}W$		
R123	Z221143	180 ohms	$\frac{1}{2}W$			
R124	Z222215	47k ohms	$\frac{1}{2}W$			
RV125	AP. 60480A	20 ohms	2.5W	Variable		
R201	Z223039	100k ohms	$\frac{3}{4}W$			
R202	Z223038	100k ohms	$\frac{1}{2}W$	Band 1 Band 2		
R203	Z221206	560 ohms	$\frac{1}{2}W$			
R204	Z222090	4.7k ohms	$\frac{3}{4}W$			
R205	Z223039	100k ohms	$\frac{3}{4}W$	Band 1 Band 2		
R206	Z223038	100k ohms	$\frac{1}{2}W$			
R207	Z221206	560 ohms	$\frac{1}{2}W$	Band 1 Band 2		
R208	Z222090	4.7k ohms	$\frac{3}{4}W$			
R209	Z223018	68k ohms	$\frac{3}{4}W$			
R210A/B	Z221131	150 ohms	$\frac{1}{2}W$	Band 1 Band 2		
R211	Z222090	4.7k ohms	$\frac{3}{4}W$			
R212	Z223081	220k ohms	$\frac{3}{4}W$			
R213	Z222152	15k ohms	$\frac{3}{4}W$			
R218	Z222090	4.7k ohms	$\frac{3}{4}W$	Band 1 Band 2		
			$\frac{3}{4}W$			

RESISTORS (Continued)

Ref.	A.P. or Joint Service Cat. No.	Value	Tol.	Rating	Remarks
R219	Z223164	1 Megohm	10%	$\frac{1}{2}W$	Variable
R220	Z262183	100k ohms	10%	$\frac{1}{2}W$	
RV221	Z222195	33k ohms	10%	$\frac{1}{2}W$	
R222	Z222090	4.7k ohms	10%	$\frac{1}{2}W$	
R223	Z223164	1 Megohm	10%	$\frac{1}{2}W$	
RV224	Z262948	2.5 Megohms	10%	1W	Variable
R225	Z223143	680k ohms	10%	$\frac{1}{2}W$	
R226	Z223143	680k ohms	10%	$\frac{1}{2}W$	
R227	Z222153	15k ohms	10%	$\frac{1}{2}W$	
R228	Z223102	330k ohms	10%	$\frac{1}{2}W$	
R229	Z223018	68k ohms	10%	$\frac{3}{4}W$	
R230	Z222131	10k ohms	10%	$\frac{1}{2}W$	
R231	Z223038	100k ohms	10%	$\frac{1}{2}W$	
R232	Z222132	10k ohms	10%	$\frac{3}{4}W$	
R233	Z221111	100 ohms	10%	$\frac{3}{4}W$	
R234	Z243173	620 ohms	5%	4.5W	
R235	Z223059	150k ohms	10%	$\frac{1}{2}W$	
R236	Z223143	680k ohms	10%	$\frac{1}{2}W$	
R237	Z223143	680k ohms	10%	$\frac{1}{2}W$	
R301	Z223207	2.2 Megohm	10%	$\frac{3}{4}W$	
R302	Z223017	68k ohms	10%	$\frac{1}{2}W$	Variable
R303	Z223101	330k ohms	10%	$\frac{1}{2}W$	
R304	Z221227	820 ohms	10%	$\frac{1}{2}W$	
RV305	Z273001	3k ohms	10%		
R306	Z223122	470k ohms	10%	$\frac{1}{2}W$	
R307	Z222215	47k ohms	10%	$\frac{1}{2}W$	Variable
R308	Z221123	120 ohms	10%	$\frac{3}{4}W$	
RV309	Z273001	50 ohms	10%		
R310	Z223144	680k ohms	10%	$\frac{3}{4}W$	
R311	Z244085	7.5k ohms	5%	4.5W	
R312	Z222069	3.3k ohms	10%	$\frac{3}{4}W$	
R313	Z244114	15k ohms	10%	6W	
R314	Z222090	4.7k ohms	10%	$\frac{3}{4}W$	

TRANSFORMERS

Ref.	Pattern No.	Description
TR101 to TR103 } TR104	65690 64686 67763A	Transformers RF
TR201 to TR203 } TR204		Transformers IF
TR301		Transformer AF
TR302		Transformer AF - Output
		Transformer Power - Mains -

INDUCTORS

Ref.	Pattern No.	Description
L101		Choke 1.5 mH, Oscillator
L102		Coil tuned, Oscillator
L201		Coil IF., IF Input
L202		Coil tuned, B.F.O.
L203		Coil Pitch, B.F.O. "Tune"
L204		Coil Pitch, B.F.O. "Law"
L205		Coil, Calibration coupling
L206		Coil tuned, Crystal filter
L302	65560	Choke, 18H, Smoothing
L304	67762	Choke, 20H, Smoothing

FUSES

Ref.	J.S. Cat. No.	Description
F301	Z590108	Fuse 0.5 Amp
F302	Z590110	Fuse 2 Amp
R303	Z590110	Fuse 2 Amp

LOUDSPEAKERS

Ref.	Pattern No.	Description
LS201	66922	Loudspeaker 3 ohms, Monitor

PLUGS AND SOCKETS

Ref.	A.P. or Joint Service Cat. No.	Description
PL101	Z560070	Plug 4 Pin, Aerial (Mk. 4)
PL103	AP.57771	Plug 4 Pin, IF Output
PL201	AP.60157	Plug 12 Pin, IF Unit/RF Unit
PL203	Z560080	Plug 6 Pin, Outputs (Mk. 4)
PL204	AP.60158	Plug 8 Pin, IF/Power Unit
PL205	AP.60157	Plug 12 Pin, IF/Power Unit
PL301	Z560050	Plug 2 Pin, Mains (Mk. 4)
SK101	AP.60156	Socket 12 Way, RF/IF Unit
SK102	AP.60451	Socket Coaxial, R.I.S.
SK201	AP.57772	Socket 4 Way, IF Input
SK202	AP.60451	Socket Single, REC
SK203	AP.60451	Socket Single, REB
SK301	AP.W3369	Socket 8 Pin, IF/AF and Power Unit
SK302	AP.60156	Socket 12 Pin, IF/AF and Power Unit

LAMPS

Ref.	J.S. Cat. No.	Description
LP101- 107	16130 X951225	Lamp Pilot 6.5V 0.3A

SWITCHES

Ref.	A.P. or Joint Service Cat. No.	Description
SW101	-	Switch Lamps, Band Indication
SW102	65638	Wafer Crystal, Crystal Switch
SW201	-	Switch 3 Position, Bandwidth
SW202	-	Switch 5 Position, System
SW203	-	Switch Single Pole, Limiter
SW204	W9836A	Switch Single Pole, Dummy Load
SW205	-	Switch Single Pole, Monitor L.S.
SW206	-	Switch 2 Position, A.G.C.
S.301	60448 or 50068	Switch Double Pole, Mains

MISCELLANEOUS

Ref.	Pattern No.	Description
XL201	67864	Crystal 500 kc/s, Calibrate
XL101	-	Crystal 2 Pin, Local Oscillator
XL202	-	Crystal, Crystal Filter
JK301	676A	Jack 3 Pole, Phones
JK302	676A	Jack 3 Pole, Phones

FIG.66

R	IO1	IO2	IO3 IO3 IO4	IO5	IO6	IO7		I12 I13 I15	I14 I21 I22	I20		I29 I26	I23	I28 I25	I24		R
C	IO2	IO1,IO3 IO9 IO4	I22		I25 I23	I24 I27		I28	I29 I60	I61	I64	I63	I85 I81,I79 I80	I78	I77 I82 I84	I83	C
MISC	SK IO1 PL IO1 RV IO1, LP IO7	MR IO1 LP IO6	LP IO5	LP IO4	LP IO3	LP IO2	LP IO1		V IO2 SW IO3b	SK IO2, SW IO3c XL IO1		V IO3 V IO4 LI O6	SW IO3d	TR I16 SK IO3 PL IO2		MISC	

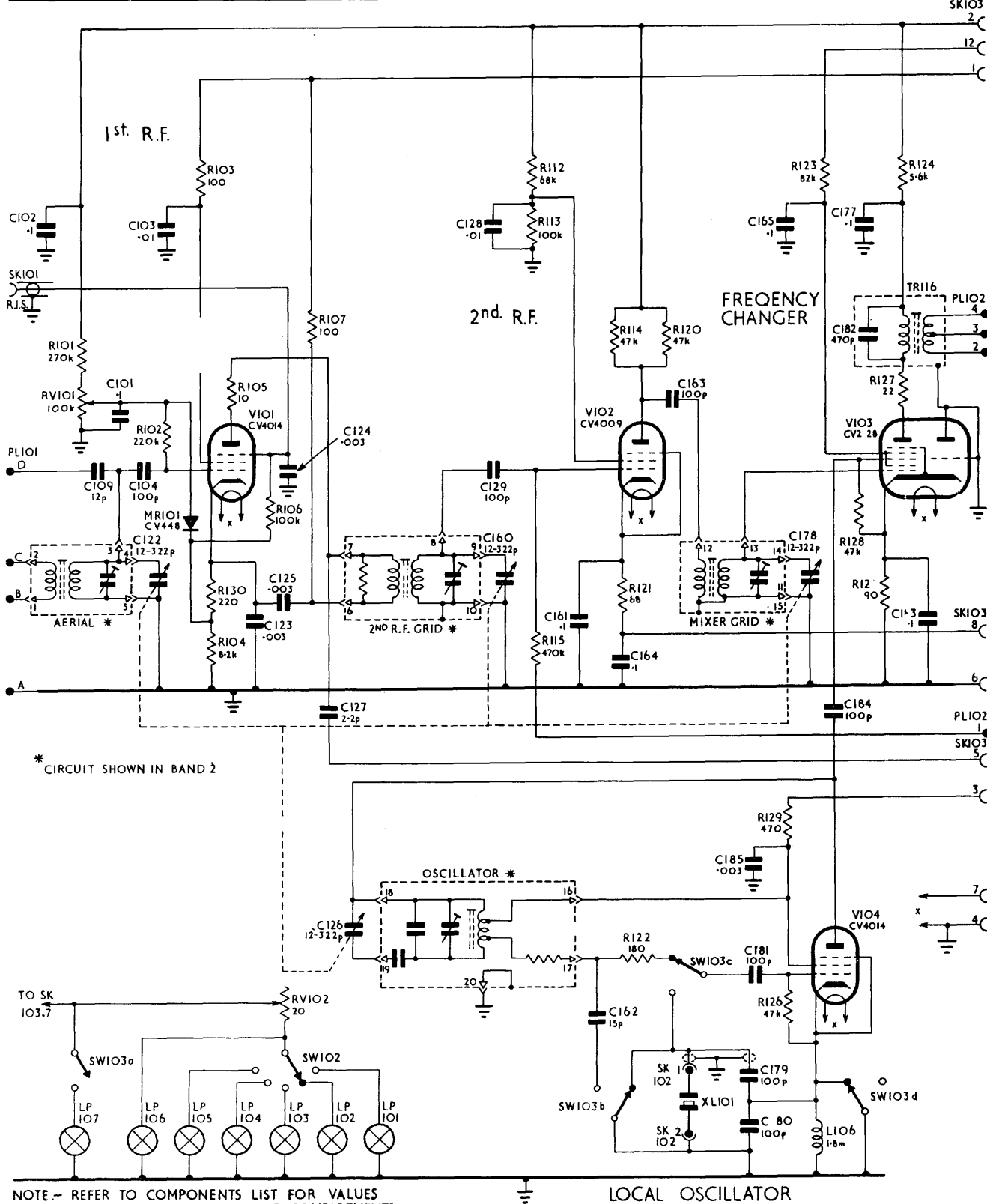

* CIRCUIT SHOWN IN BAND 2

NOTE.- REFER TO COMPONENTS LIST FOR VALUES OF COMPONENTS IN TURRET COMPARTMENTS

R.F. UNIT

R	201 202 234	203 218	204 240	205 207	206 210	208 212	209 239	210 227	211 229	212 229	213 233	214 231	215 233	216 231	217 233	218 233	219 233	220 233	221 233	222 233	223 233	224 233	225 233	226 233	227 233	228 233	229 233	230 233	231 233	232 233	233 233	234 233	235 233	236 233	237 233			
C	202 201	223	205 203	204 206,240	242 241	238 222	221	220	207 210 218	208	209,212,211	217	215 216	214	222	223	237	235	236,234																			
MISC	PL201, SW201a, L201 SK201 PL202	V201 SW204	TR201 SW206d	SW201f SW201b	XL202 SW201j SW206ac	SW201k, SW201h, L206 SW202j	SW201g SW202q SW202k	V202 SW202q SW202k	TR202 K204 XL20	SW201c SW202p SW202m	V203 SK202 L204 L203	V204A L202 L206	TR203																									

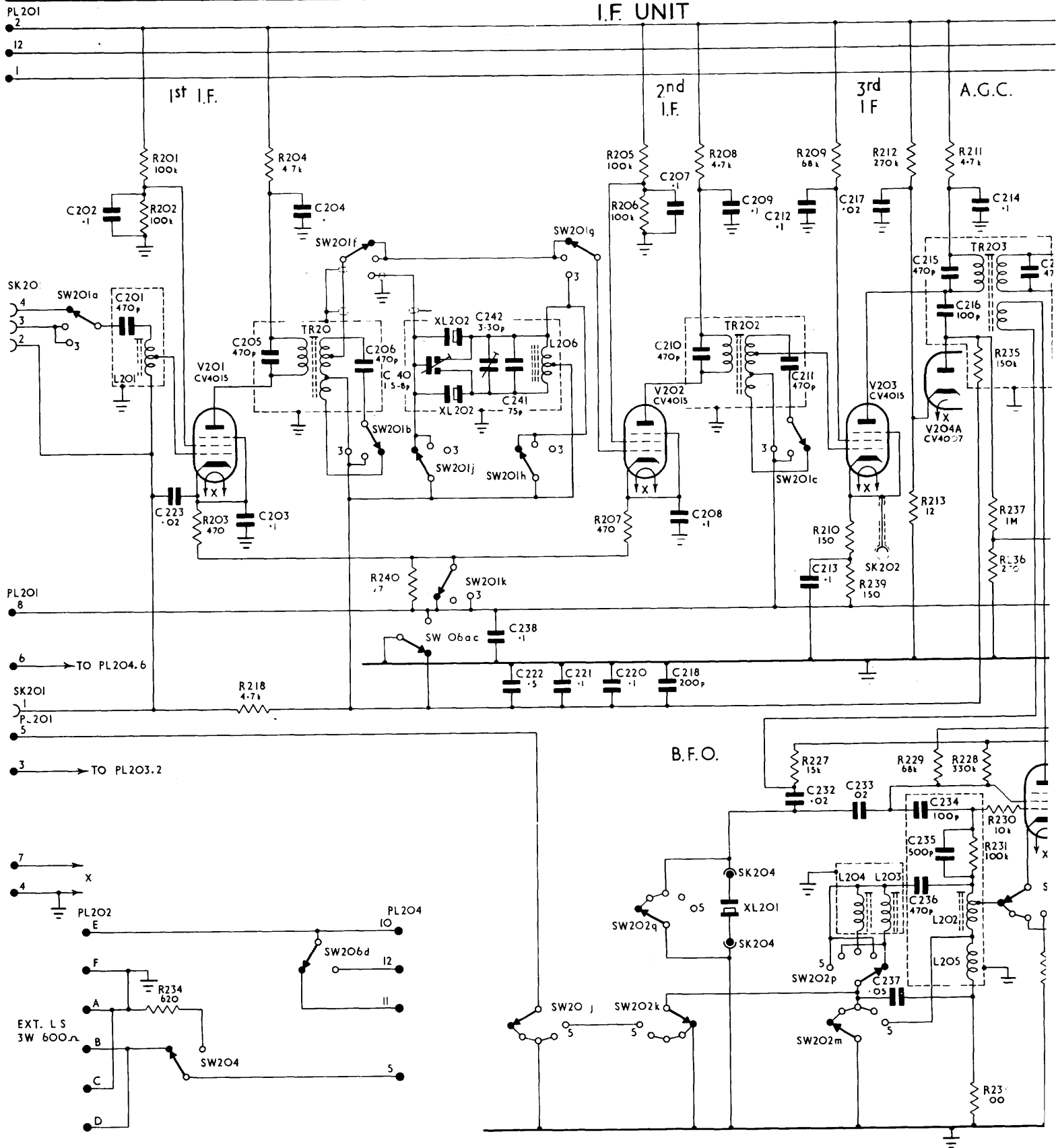

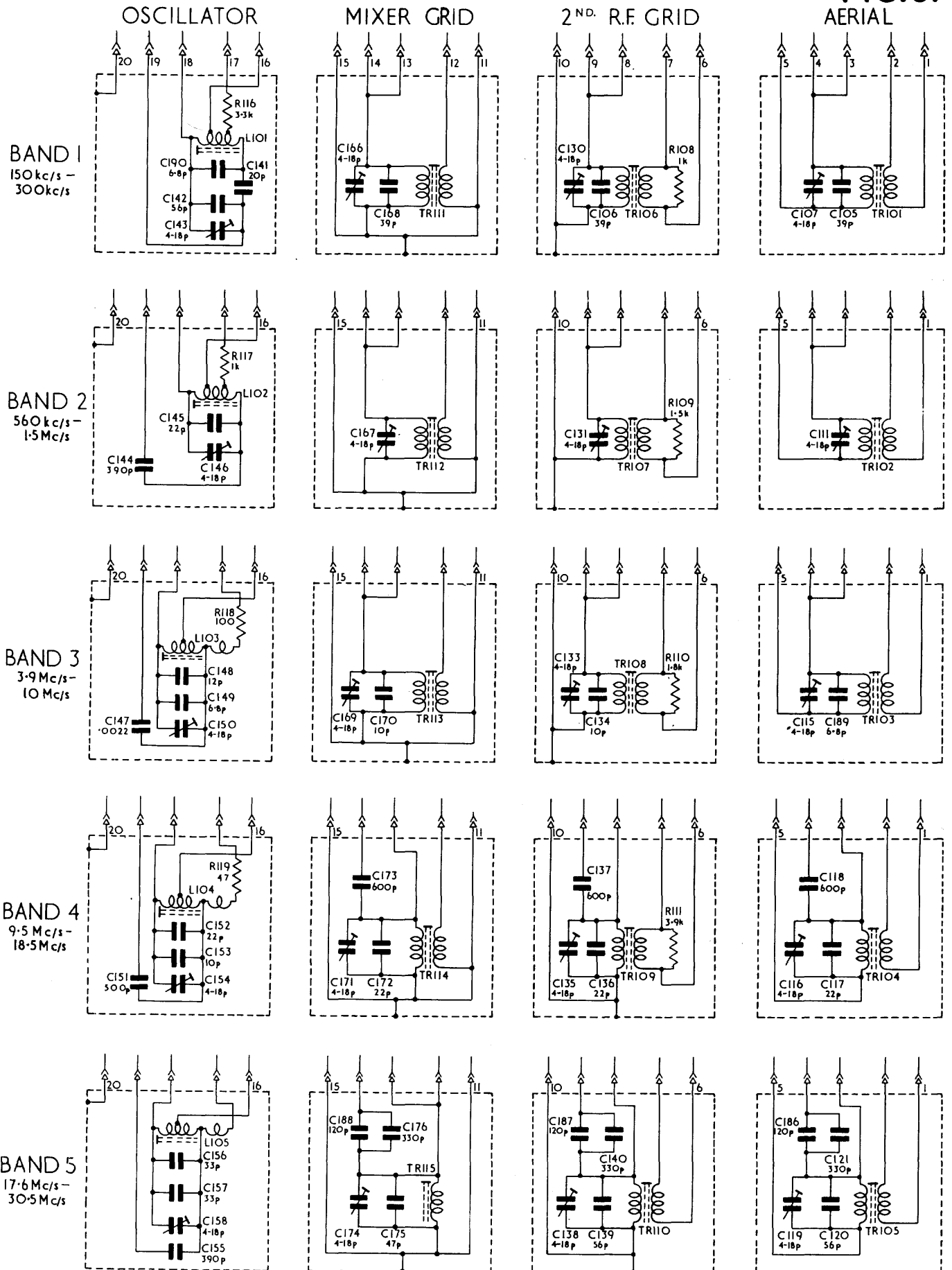

RECEIVER 62B AP. 67757 A.
 TURRET SWITCH COMPONENTS. CIRCUIT DIAGRAM

COMPONENTS LIST - RECEIVER 62B A.P.67757ACAPACITORS

Ref.	A.P. or Joint-Service Cat. No.	Value	Tol. ±	Rating	Remarks
C101	011-5095	0.1 μ F	20%	350V	
C102	011-5095	0.1 μ F	20%	350V	
C103	012-4407	0.01 μ F	20%	350V	
C104	012-3165	100 pF	20%	350V	
C105	012-7103	39 pF	5%	750V	
C106	012-7103	39 pF	5%	750V	
C107	016-0009	4-18 pF			Trimmer
C108					
C109	012-7091	12 pF	5%	750V	
C110					
C111	016-0009	4-18 pF			Trimmer
C112					
C113					
C114					
C115	016-0009	4-18 pF			Trimmer
C116	016-0009	4-18 pF			Trimmer
C117	012-7097	22 pF	5%	750V	
C118	972-9507	600 pF	5%	350V	
C119	016-0009	4-18 pF			Trimmer
C120	012-7107	56 pF	2%	750V	
C121	012-3941	330 pF	2%	750V	
C122	A.P. 60189	12-32 pF	$\frac{1}{2}$ %		Trimmer
C123	911-5674	0.003 μ F	20%	350V	
C124	911-5674	0.003 μ F	20%	350V	
C125	911-5674	0.003 μ F	20%	350V	
C126	A.P. 60189	12-322 pF	$\frac{1}{2}$ %		
C127	012-7081	2.2 pF	0.5 pF	500V	
C128	012-4407	0.01 μ F	20%	350V	
C129	012-3165	100 pF	20%	350V	
C130	016-0009	4-18 pF	10%		
C131	016-0009	4-18 pF	10%		Trimmer
C132					
C133	016-0009	4-18 pF	10%		Trimmer
C134	012-7089	10 pF	0.5 pF	750V	
C135	016-0009	4-18 pF	10%		Trimmer

CAPACITORS (Cont'd.)

Ref.	A.P. or Joint-Service Cat. No.	Value	Tol. ±	Rating	Remarks
C136	012-7097	22 pF	5%	750V	
C137	972-9507	600 pF	5%	350V	
C138	016-0009	4-18 pF	10%		Trimmer
C139	012-7107	56 pF	2%	750V	
C140	012-3941	330 pF	2%	750V	
C141	012-3927	120 pF	5%	350V	
C142	012-7107	56 pF	2%	750V	
C143	016-0009	4-18 pF	10%		Trimmer
C144	012-3944	390 pF	2%	350V	
C145	012-7097	22 pF	5%	750V	
C146	016-0009	4-18 pF	10%		Trimmer
C147	972-2143	2200 pF	5%	350V	
C148	012-7091	12 pF	5%	750V	
C149	011-8276	6.8 pF	20%	500V	
C150	016-0009	4-18 pF	10%		Trimmer
C151	911-4646	500 pF	5%	350V	
C152	012-7097	22 pF	2%	750V	
C153	911-4958	10 pF	5%	350V	
C154	016-0009	4-18 pF	10%		Trimmer
C155	012-3945	390 pF	5%	350V	
C156	012-7101	33 pF	5%	750V	
C157	012-3908	33 pF	5%	350V	
C158	016-0009	4-18 pF	10%		Trimmer
C159					
C160	A.P. 60189	12-322 pF	±2%		Trimmer
C161	011-5095	0.1 μF	20%	350V	
C162	012-7093	15 pF	5%	750V	
C163	012-3165	100 pF	20%	350V	
C164	011-5095	0.1 μF	20%	350V	
C165	011-5095	0.1 μF	20%	350V	
C166	016-0009	4-18 pF	20%		Trimmer
C167	016-0009	4-18 pF	20%		Trimmer
C168	012-7103	39 pF	5%	750V	
C169	016-0009	4-18 pF	20%		Trimmer
C170	012-7089	10 pF	0.5 pF	750V	
C171	016-0009	4-18 pF	20%		Trimmer
C172	012-7097	22 pF	5%	750V	
C173	972-9507	600 pF	5%	350V	
C174	016-0009	4-18 pF	20%		Trimmer
C175	012-7105	47 pF	2%	750V	

CAPACITORS (Cont'd.)

Ref.	A.P. or Joint-Service Cat. No.	Value	Tol. ±	Rating	Remarks
C176	012-3941	330 pF	2%	750V	Ganged Capacitor
C177	011-5095	0.1 μ F	20%	350V	
C178	A.P.60189	12-322 pF	1%		
C179	012-3165	100 pF	20%	350V	
C180	012-3165	100 pF	20%	350V	
C181	012-7113	100 pF	2%	750V	
C182	012-3948	470 pF	5%	350V	
C183	011-5095	0.1 μ F	20%	350V	
C184	012-7113	100 pF	2%	750V	
C185	911-5674	0.003 μ F	20%	350V	
C186	012-3926	120 pF	2%	750V	
C187	012-3926	120 pF	2%	750V	
C188	012-3926	120 pF	2%	750V	
C189	012-7087	6.8 pF	0.5 pF	750V	
C190	012-6772	6.8 pF	0.5 pF	750V	
C201	012-3948	470 pF	5%	350V	
C202	011-7818	0.1 μ F	20%	350V	
C203	011-5095	0.1 μ F	20%	350V	
C204	011-5095	0.1 μ F	20%	350V	
C205	012-3948	470 pF	5%	350V	
C206	012-3948	470 pF	5%	350V	
C207	011-5095	0.1 μ F	20%	350V	
C208	011-5095	0.1 μ F	20%	350V	
C209	011-5095	0.1 μ F	20%	350V	
C210	012-3948	470 pF	5%	350V	
C211	012-3948	470 pF	5%	350V	
C212	011-5095	0.1 μ F	20%	350V	
C213	011-5095	0.1 μ F	20%	350V	
C214	011-5095	0.1 μ F	20%	350V	
C215	012-3948	470 pF	5%	350V	
C216	012-3165	100 pF	20%	350V	
C217	011-7826	0.02 μ F	20%	750V	
C218	012-3292	220 pF	20%	350V	
C219					
C220	011-5095	0.1 μ F	20%	350V	
C221	011-5095	0.1 μ F	20%	350V	
C222	011-5148	0.5 μ F	20%	350V	
C223	011-7826	0.02 μ F	20%	750V	
C224	012-3292	220 pF	20%	350V	
C225	011-5095	0.1 μ F	20%	350V	

CAPACITORS (Cont'd.)

Ref.	A.P. or Joint-Service Cat. No.	Value	Tol. ±	Rating	Remarks
C226	012-3948	470 pF	5%	350V	
C227	012-3165	100 pF	20%	350V	
C228	012-3292	220 pF	10%	750V	
C229	011-7827	0.005 μ F	20%	1000V	
C230	011-5095	0.1 μ F	20%	350V	
C231	012-3412	470 pF	10%	750V	
C232	011-7826	0.02 μ F	20%	750V	
C233	011-7826	0.02 μ F	20%	750V	
C234	012-3165	100 pF	20%	350V	
C235	012-3412	470 pF	10%	350V	
C236	012-3948	470 pF	5%	350V	
C237	011-7822	0.05 μ F	20%	500V	
C238	011-5095	0.1 μ F	20%	350V	
C239					
C240	945-4604	1.5/8 pF	1.5-8p		Trimmer (OXLEY differential)
C241	972-2071	75 pF	2%	350V	I.F.M. Co. 1510
C242	016-0047	3-30 pF	5%		Trimmer W & R C30/01
C243					
C244					
C245					
C246					
C247					
C248					
C249	012-3165	100 pF	20%	750V	
C302					
C303	011-9832	0.25 μ F	20%	350V	
C304	011-5525	0.01 μ F	20%	500V	
C305	011-2926	4 μ F	20%	400V	
C306	011-2926	4 μ F	20%	400V	
C307					
C308					
C309	012-4409	0.01 μ F	20%	750V	
C310	012-4409	0.01 μ F	20%	750V	
C311	012-4409	0.01 μ F	20%	750V	
C312	012-4409	0.01 μ F	20%	750V	
C313	011-7827	0.004 μ F	20%	1000V	
C314	932-2513	8 μ F	20%	400V	Type 82
C315	932-2513	8 μ F	20%	400V	Type 82

CAPACITORS (Cont'd.)

Ref.	A.P. or Joint-Service Cat. No.	Value	Tol. ±	Rating	Remarks
C316	580-1816	0.02 μ F	10%	350V	
C317	911-6793	0.1 μ F	10%	350V	
C318	011-5554	0.05 μ F	20%	350V	
C319	011-7821	1 μ F	20%	350V	

RESISTORS

Ref.	A.P. or Joint-Service Cat. No.	Value	Tol. ±	Rating	Remarks
R101	022-3091	270k ohms	10%	$\frac{1}{2}$ W	
R102	022-3079	220k ohms	10%	$\frac{1}{2}$ W	
R103	022-1109	100 ohms	10%	$\frac{1}{2}$ W	
R104	022-2123	8.2k ohms	10%	$\frac{3}{4}$ W	
R105	022-1002	10 ohms	10%	$\frac{1}{2}$ W	
R106	022-3037	100k ohms	10%	$\frac{1}{2}$ W	
R107	022-1109	100 ohms	10%	$\frac{1}{2}$ W	
R108	022-2004	1k ohm	10%	$\frac{1}{2}$ W	
R109	022-2025	1.5k ohms	10%	$\frac{1}{2}$ W	
R110	022-2037	1.8k ohms	10%	$\frac{1}{2}$ W	
R111	022-2079	3.9k ohms	10%	$\frac{1}{2}$ W	
R112	022-3018	68k ohms	10%	$\frac{3}{4}$ W	
R113	022-3037	100k ohms	10%	$\frac{1}{2}$ W	
R114	022-2216	4.7k ohms	10%	$\frac{3}{4}$ W	
R115	022-3121	470k ohms	10%	$\frac{1}{2}$ W	
R116	022-2067	3.3k ohms	10%	$\frac{1}{2}$ W	
R117	022-2004	1k ohm	10%	$\frac{1}{2}$ W	
R118	022-1142	180 ohms	10%	$\frac{1}{2}$ W	
R119	022-1067	47 ohms	10%	$\frac{1}{2}$ W	
R120	022-2216	4.7k ohms	10%	$\frac{3}{4}$ W	
R121	022-1088	68 ohms	10%	$\frac{1}{2}$ W	
R122	022-1142	180 ohms	10%	$\frac{1}{2}$ W	
R123	022-3030	82k ohms	10%	$\frac{3}{4}$ W	
R124	022-2100	5.6k ohms	10%	$\frac{1}{2}$ W	
R125	022-1184	390 ohms	10%	$\frac{1}{2}$ W	
R126	022-2214	4.7k ohms	10%	$\frac{1}{2}$ W	
R127	022-1026	22 ohms	10%	$\frac{1}{2}$ W	
R128	022-2214	4.7k ohms	10%	$\frac{1}{2}$ W	
R129	022-2079	3.9k ohms	10%	$\frac{1}{2}$ W	
R130	022-1151	220 ohms	10%	$\frac{1}{2}$ W	

RESISTORS (Cont'd.)

Ref.	A.P. or Joint-Service Cat. No.	Value	Tol. ±	Rating	Remarks
R201	C22-3039	100k ohms	10%	$\frac{3}{4}$ W	
R202	022-3037	100k ohms	10%	$\frac{1}{2}$ W	
R203	022-1193	470 ohms	10%	$\frac{1}{2}$ W	
R204	022-2090	4.7k ohms	10%	$\frac{3}{4}$ W	
R205	022-3039	100k ohms	10%	$\frac{3}{4}$ W	
R206	022-3037	100k ohms	10%	$\frac{1}{2}$ W	
R207	022-1193	470 ohms	10%	$\frac{1}{2}$ W	
R208	022-2090	4.7k ohms	10%	$\frac{3}{4}$ W	
R209	022-3018	68k ohms	10%	$\frac{3}{4}$ W	
R210	C22-1130	150 ohms	10%	$\frac{1}{2}$ W	
R211	022-2090	4.7k ohms	10%	$\frac{3}{4}$ W	
R212	022-3093	270k ohms	10%	$\frac{3}{4}$ W	
R213	022-2142	12k ohms	10%	$\frac{1}{2}$ W	
R214					
R215					
R218	022-2090	4.7k ohms	10%	$\frac{3}{4}$ W	
R219	C22-3164	1M ohm	10%	$\frac{1}{2}$ W	
R221	022-2195	33k ohms	10%	$\frac{3}{4}$ W	
R222	022-2090	4.7k ohms	10%	$\frac{3}{4}$ W	
R223	022-3164	1M ohm	10%	$\frac{1}{2}$ W	
R225	022-3143	680k ohms	10%	$\frac{1}{2}$ W	
R226	022-3143	680k ohms	10%	$\frac{1}{2}$ W	
R227	022-2153	15k ohms	10%	$\frac{3}{4}$ W	
R228	022-3102	330k ohms	10%	$\frac{3}{4}$ W	
R229	022-3018	68k ohms	10%	$\frac{3}{4}$ W	
R230	022-2130	10k ohms	10%	$\frac{1}{2}$ W	
R231	022-3037	100k ohms	10%	$\frac{1}{2}$ W	
R232	022-2132	10k ohms	10%	$\frac{3}{4}$ W	
R233	022-1111	100 ohms	10%	$\frac{3}{4}$ W	
R234	011-3482	620 ohms	5%	4.5W	Wirewound
R235	022-3058	150k ohms	10%	$\frac{1}{2}$ W	
R236	022-3091	270k ohms	10%	$\frac{1}{2}$ W	
R237	022-3176	1.2M ohms	10%	$\frac{1}{2}$ W	
R238	022-2214	47k ohms	10%	$\frac{1}{2}$ W	
R239	022-1130	150 ohms	10%	$\frac{1}{2}$ W	
R240	022-1163	270 ohms	10%	$\frac{1}{2}$ W	
R301	022-3206	2.2M ohms	10%	$\frac{3}{4}$ W	
R302	022-3028	82k ohms	10%	$\frac{1}{2}$ W	
R303	022-3079	220k ohms	10%	$\frac{1}{2}$ W	
R304	022-1151	220 ohms	10%	$\frac{1}{2}$ W	
R305					

RESISTORS (Cont'd.)

Ref.	A.P. or Joint-Service Cat. No.	Value	Tol. ±	Rating	Remarks
R306	022-3121	4.70k ohms	10%	$\frac{1}{2}W$	
R307	022-2214	4.7k ohms	10%	$\frac{1}{2}W$	
R308	022-1195	4.70 ohms	10%	$\frac{3}{4}W$	
R309					
R310					
R311	011-3508	7.5k ohms	5%	4.5W	Wirewound
R312	022-2069	3.3k ohms	10%	$\frac{3}{4}W$	
R313	011-3425	15k ohms	5%	6W	Wirewound
R314	022-2048	2.2k ohms	10%	$\frac{3}{4}W$	
R315	022-1195	4.70 ohms	10%	$\frac{3}{4}W$	

VARIABLE RESISTORS

Ref.	A.P. or Joint-Service Cat. No.	Value	Tol. ±	Rating	Remarks
RV101	900-4942	100k ohms	20%	$\frac{1}{4}W$	
RV102	580-3198	20 ohms	10%	2.5W	
RV220	972-9484	100k ohms	20%	0.1W	
RV224	972-9482	2.5M ohms	20%	0.1W	
RV305	580-0482	3k ohms	10%		
RV309		50 ohms	10%		

VALVES

Ref.	A.P. or Joint-Service Cat. No.	Description
V101	000-4014	
V102	000-4009	
V103	000-2128	
V104	000-4014	
V201	000-4015	
V202	000-4015	
V203	000-4015	
V204	000-4007	
V205	000-4007	
V206	000-4015	

VALVES (Cont'd.)

Ref.	A.P. or Joint-Service Cat. No.	Description
V301	000-4009	
V302	000-4043	
V303	000-4005	
V304	000-4005	
V305	000-4100	

INDUCTORS

Ref.	A.P. or Joint-Service Cat. No.	Description
L101	A.P.106096	Coil Tuned Osc. Band 1
L102	A.P.106097	Coil Tuned Osc. Band 2
L103	A.P.106114	Coil Tuned Osc. Band 3
L104	A.P.106115	Coil Tuned Osc. Band 4
L105	A.P.106116	Coil Tuned Osc. Band 5
L106	A.P.106151	Choke 1.5 mH
L201	A.P.106118	Coil I.F.
L202	A.P.106121	Coil Tuned
L203	A.P.106123	Coil Pitch (Low)
L204	A.P.106124	Coil Pitch (Tune)
L205	A.P.106098	Coil B.F.O.
L206	A.P.106124	Coil Wound
L302	971-9618	Choke 18H
L303		
L304	971-9595	Choke 20H

LOUDSPEAKER

Ref.	A.P. or Joint-Service Cat. No.	Description
LS201	972-9307	Loudspeaker

TRANSFORMERS

Ref.	A.P. or Joint-Service Cat. No.	Description
TR101	A.P.106090	Transformer R.F. Aerial Band 1
TR102	A.P.106091	Transformer R.F. Aerial Band 2
TR103	A.P.184028	Transformer R.F. Aerial Band 3
TR104	A.P.184029	Transformer R.F. Aerial Band 4
TR105	A.P.184030	Transformer R.F. Aerial Band 5
TR106	A.P.106092	Transformer R.F. 1st R.F. Aerial Band 1
TR107	A.P.106093	Transformer R.F. 1st R.F. Aerial Band 2
TR108	A.P.106108	Transformer R.F. 1st R.F. Aerial Band 3
TR109	A.P.106109	Transformer R.F. 1st R.F. Aerial Band 4
TR110	A.P.106110	Transformer R.F. 1st R.F. Aerial Band 5
TR111	A.P.106094	Transformer R.F. 2nd R.F. Aerial Band 1
TR112	A.P.106095	Transformer R.F. 2nd R.F. Aerial Band 2
TR113	A.P.106111	Transformer R.F. 2nd R.F. Aerial Band 3
TR114	A.P.106112	Transformer R.F. 2nd R.F. Aerial Band 4
TR115	A.P.106113	Transformer R.F. 2nd R.F. Aerial Band 5
TR116	A.P.106117	Transformer I.F.
TR201	A.P.106119	Transformer I.F.
TR202	A.P.106119	Transformer I.F.
TR203	A.P.106120	Transformer I.F.
TR301	972-0053	Transformer Output
TR302	971-9596	Transformer Mains
TR303	971-9513	Transformer Output Monitor Loudspeaker

SWITCHES

Ref.	A.P. or Joint-Service Cat. No.	Description
SW102	48976	Switch Band Indicator
SW103	A808202	Switch Crystal
SW201	A.P.206828	Switch Bandwidth (wafer as for B40)
SW202	A.P.206830	Switch System (wafer as for B40)
SW203	972-8826	Switch Limiter
SW204	A.P.43669	Switch Single Pole
SW206	972-8825	Switch A.G.C.
SW301	933-0018	Switch Two Pole
SW302	972-5014	Switch Single Pole

PLUGS AND SOCKETS

Ref.	A.P. or Joint-Service Cat. No.	Description
PL101	999-3526	Plug 4 Pin Fixed
PL102	972-8183) 972-8214)	Plug Painton 4 way
PL201	972-8185) 972-8210)	Plug Painton 12 way
PL202	972-9112	Plug 6 Pin Fixed
PL203	911-6428) 972-8208)	Plug Painton 8 way
PL204	972-8185) 972-8210)	Plug Painton 12 way
PL301	999-3528	Plug 2 Pin Fixed
SK101	580-3620	Socket Coaxial
SK102		Socket (Crystal)
SK103	972-8233	Socket Painton 12 way
SK201	972-8230	Socket Painton 4 way
SK202	580-3620	Socket Coaxial
SK203	580-3620	Socket Coaxial
SK204		Socket (Crystal)
SK301	972-8232	Socket Painton 8 way
SK302	972-8233	Socket Painton 12 way

FUSES

Ref.	A.P. or Joint-Service Cat. No.	Value	Description
FS301	059-0108	0.5A	Fuse Cartridge
FS302	059-0110	2A	Fuse Cartridge
FS303	059-0110	2A	Fuse Cartridge

LAMPS

Ref.	A.P. or Joint-Service Cat. No.	Value	Description
LP101	995-1225	6.5V 3A	Lamp Pilot
LP102	995-1225	6.5V 3A	Lamp Pilot
LP103	995-1225	6.5V 3A	Lamp Pilot
LP104	995-1225	6.5V 3A	Lamp Pilot
LP105	995-1225	6.5V 3A	Lamp Pilot
LP106	995-1225	6.5V 3A	Lamp Pilot
LP107	995-1225	6.5V 3A	Lamp Pilot

MISCELLANEOUS

Ref.	A.P. or Joint-Service Cat. No.	Description
MR101	037-2373	CV7130 Germanium Rectifier
XL201	A.P.67684	Crystal 500 kc/s - b.f.o.
XL202	-	Crystal 50 kc/s - Filter
JK301	972-9652	Jack 3 Pole
JK302	972-9652	Jack 3 Pole

The following sheets contain details of the Pattern numbers of Transformers, Coils and Switches for units of A.P.57140/A/B/C/D and A.P.67757/A Receivers. The relevant items in the component lists in B.R.1617 should be annotated to the effect that further information is available at the rear of the book.

Receiver A.P. No.	Circuit Ref.	Description	A.P.No.	NSN
57140/A/B/C	TR101	Aerial Transformer, Band 1	184026	
		Band 2	184027	
		Band 3	184028	
		Band 4	184029	
		Band 5	184030	
57140/A/B/C	TR102	R.F. Grid Coil (1st r.f.) Band 1	106099	
		Band 2	106100	
		Band 3	106108	
		Band 4	106109	
		Band 5	106110	
57140/A/B/C	TR103	Mixer Grid Coil (2nd r.f.) Band 1	106101	
		Band 2	106102	
		Band 3	106111	
		Band 4	106112	
		Band 5	106113	
57140/A/B/C	L102	Oscillator Coil Band 1	106103	
		Band 2	106104	
		Band 3	106114	
		Band 4	106115	
		Band 5	106116	
57140/A/B/C	TR104	I.F. Assembly	106117	
		L201 I.F. Assembly	106118	
57140/A/B/C	L202/5	B.F.O. Assembly	106121	
		L203 Pitch Coil (Low)	106123	
		L204 Pitch Coil (Tune)	106122	
57140/A	TR201/2	I.F. Assembly	106105	
		TR203 I.F. Assembly	106106	
		L301 Choke 1H (Filter)	106152	
57140B/C	TR201/2	Crystal Filter	106107	
		I.F. Assembly	106119	
		TR203 I.F. Assembly	106120	
		L206 Coil Tuned (500 kc/s)	106124	
		L101 Choke 1.5 mH	106151	
57140D	TR101	Aerial Transformer, Band 1	184026	
		TR102 Band 2	184027	
		TR103 Band 3	184028	
		TR104 Band 4	184029	
		TR105 Band 5	184030	

Receiver A.P. No.	Circuit Ref.	Description	A.P.No.	NSN
57140D	TR106	R.F. Grid Coil (1st r.f.) Band 1	106099	
	TR107	Band 2	106100	
	TR108	Band 3	106108	
	TR109	Band 4	106109	
	TR110	Band 5	106110	
57140D	TR111	Mixer Grid Coil (2nd r.f.) Band 1	106101	
	TR112	Band 2	106102	
	TR113	Band 3	106111	
	TR114	Band 4	106112	
	TR115	Band 5	106113	
57140D	L101	Oscillator Coil Band 1	106103	
	L102	Band 2	106104	
	L103	Band 3	106114	
	L104	Band 4	106115	
	L105	Band 5	106116	
57140D	TR116	I.F. Assembly	106117	
	L201		106118	
	TR201/2		106119	
	TR203		106120	
57140D	L202/5	B.F.O. Assembly	106121	
	L206	Coil Tuned (500 kc/s)	106124	
	L106	Choke 1.5 mH	106151	
		Crystal Filter	106107	

Receiver A.P. No.	Circuit Ref.	Description	A.P. No.	NSN
57140/A	SW201	<u>SWITCHES</u> Switch 3 Position, Bandwidth 4 Items (i) Wafer (ii) Wafer (iii) Wafer (iv) Mechanism	65631 65632 65633 65639	
57140B/C	SW201	Switch 3 Position, Bandwidth 5 Items (i) Wafer (ii) Wafer (iii) Wafer (iv) Wafer (v) Mechanism	65631 65632 65633 5930-A.P. 206820 5930-A.P. 206828	
57140D	SW201	Switch 3 Position, Bandwidth 5 Items (i) Wafer (ii) Wafer (iii) Wafer (iv) Wafer (v) Mechanism	65631 65632 5930-A.P. 206820 5930-A.P. 206821 5930-A.P. 206828	
57140/A	SW202	Switch 6 Position, System 4 Items (i) Wafer (ii) Wafer (iii) Wafer (iv) Mechanism	65634 65635 65636 65640	
57140B/C	SW202	Switch 5 Position, System 4 Items (i) Wafer (ii) Wafer (iii) Wafer (iv) Mechanism	65634 65635 65636 5930-A.P. 206829	
57140D	SW202	Switch 7 Position, System 5 Items (i) Wafer (ii) Wafer (iii) Wafer (iv) Wafer (v) Mechanism	5930-A.P. 206824 5930-A.P. 206825 5930-A.P. 206822 5930-A.P. 206823 5930-A.P. 206830	

Circ. Ref. A.P.67757	Circ. Ref. A.P.67757A	Description	A.P. No.	NSN
TR101	TR101 TR102 TR103 TR104 TR105	Aerial Transformer Band 1 Band 2 Band 3 Band 4 Band 5	184028 184029 184030	
TR102	TR106 TR107 TR108 TR109 TR110	R.F. Grid Coil (1st r.f.) Band 1 Band 2 Band 3 Band 4 Band 5	106108 106109 106110	
TR103	TR111 TR112 TR113 TR114 TR115	Mixer Grid Coil (2nd r.f.) Band 1 Band 2 Band 3 Band 4 Band 5	106111 106112 106113	
L102	L101 L102 L103 L104 L105	Oscillator Coil Band 1 Band 2 Band 3 Band 4 Band 5	106114 106115 106116	
TR104 L201 TR201/2 TR203	TR116 L201 TR201/2 TR203	I.F. Assembly	106117 106118 106119 106120	
L202/5		B.F.O. Assembly	106121	
L204 L203 L206 L101	L204 L203 L206 L106	Pitch Coil (Tune) Pitch Coil (Low) Coil Tuned (500 kc/s) Choke 1.5 mH	106122 106123 106124 106151	