

CONTENTS

SECTION 1

OPERATING AND DESCRIPTION TECHNICAL SPECIFICATION

		Page
Chapter 1	INTRODUCTION	1 - 1
	General Description	1 - 1
	Mechanical Description	1 - 2
Chapter 2	OPERATING INSTRUCTIONS	2 - 1
	INSTALLATION	2 - 1
	Determination of Channel Crystal Frequencies	2 - 1
	SETTING-UP	2 - 1
	Switching On	2 - 1
	Crystal Fine Tuning - Channel Crystal Control	2 - 2
	Calibration of 1.6 Mc/s	2 - 3
	Calibration of KC/S Scale	2 - 4
	Setting-Up Audio Input Level	2 - 5
	Setting-Up Carrier Levels	2 - 5
	Setting-Up Frequency Deviation	2 - 5
	Additional Facilities	2 - 6
	OPERATING INSTRUCTIONS	2 - 7
	Tuning Procedure for A1 Emission	2 - 7
	Tuning Procedure for A2, A3, A3A, A3H and A3J Modes of Emission	2 - 8
	Tuning Procedure for F1 Emission	2 - 9
Chapter 3	PRINCIPLES OF OPERATION	3 - 1
	Introduction	3 - 1
	FREQUENCY GENERATING STAGES	3 - 1
	Preliminary	3 - 1
	Wadley System	3 - 1
	Electronic Bandswitching	3 - 2
	CALIBRATION STAGES	3 - 3

	Page
Chapter 3 (cont'd).	
Preliminary	3 - 3
Regenerative Dividing	3 - 3
Chapter 4	
CIRCUIT DESCRIPTION	4 - 1
Introduction	4 - 1
SIGNAL FLOW	4 - 1
General	4 - 1
S.S.B./D.S.B. - Internal Modulation	4 - 1
I.S.B./S.S.B. External Modulator (MA. 79G only)	4 - 3
A.M. Compatible	4 - 3
C.W. Keying	4 - 3
F.S.K. Operation	4 - 3
STAGE DESCRIPTIONS	4 - 3
A.F. Stages	4 - 3
I.F. Stages	4 - 4
Frequency Selection Stages	4 - 5
Tuned Output Stages	4 - 6
ANCILLARY STAGES	4 - 8
Calibration Stages	4 - 8
Power Supplies	4 - 8
SECTION 2	
MAINTENANCE	
Chapter 1	
ROUTINE MAINTENANCE	1 - 1
General	1 - 1
Kilocycles Scale	1 - 1
Chapter 2	
DISMANTLING AND REASSEMBLY	2 - 1
Introduction	2 - 1
Dismantling	2 - 3
Re-assembly	2 - 5
Chapter 3	
ALIGNMENT PROCEDURES	3 - 1
Introduction	3 - 1
Test Equipment	3 - 1

	<u>Page</u>
Initial Procedure	3 - 3
Kc/s V.F.O. Output	3 - 4
2 to 3 Mc/s Filter Output	3 - 4
F.S.K. and Fine Frequency Calibration	3 - 5
Mc/s V.F.O. Calibration	3 - 8
Kc/s V.F.O. Calibration	3 - 9
Pilot Carrier Check	3 - 10
Input Level Checks	3 - 10
F.S.K. and Keying Checks	3 - 11
Output Level Check	3 - 12
Crystal Frequency Stability	3 - 12
V.F.O. Frequency Stability	3 - 13
Harmonic Distortion Check	3 - 14
Two Tone Distortion	3 - 14
A.L.C. Check	3 - 15
1.4 Mc/s Output Check	3 - 16
1.4 Mc/s Input Check	3 - 17
R.F. Levels - Modulator Chassis	3 - 17
C.W. Conditions	3 - 17
R.F. Levels - Main Chassis	3 - 20
Chapter 4	
FAULT LOCATION AND REPRESENTATIVE TEST DATA	4 - 1
Introduction	4 - 1
Test Equipment	4 - 1
Static Voltages	4 - 2
Modulator Chassis	4 - 6
Calibration Chassis	4 - 8
MAIN CHASSIS	4 - 10
Harmonic Generating Stages (V1, V3 and V11)	4 - 10
37.5 Mc/s Stages (V11, V15, V18 and V14)	4 - 11

Chapter 4 (cont'd).		Page
	40 Mc/s Filter and Amplifier (V17)	4 - 12
	Mc/s V. F. O. Stages	4 - 12
	OVERALL CHECK	4 - 14
Chapter 5	PARTS LIST	
Chapter 6	LIST OF N. A. T. O. STOCK NUMBERS	

ILLUSTRATIONS

		<u>Fig.</u>
	Block Diagram MA. 79G	1
	Circuit 1: Modulation and I. F. Stages	2
	Circuit 2: Calibration and Output Stages	3
	Ancillary Circuits	4
	Circuit: Filters	5
	Switch Details	6
	Layout: Plan View	7
	Layout 1: Main Chassis	8
	Layout 2: Main Chassis	9
	Layout: Modulation Chassis	10
	Rear View: Main Chassis	11
	Layout: Mc/s V. F. O. Chassis	12
	Layout: Kc/s V. F. O. Chassis	13
	Kc/s V. F. O. Drive Mechanism	14
	1 Mc/s Adaptor (PL16)	15

APPENDIX 1	UNIVERSAL DRIVE UNIT TYPE MA. 79H	<u>Page</u>
	Introduction	A-1
	Operation	A-1
	Detailed Technical Description	A-1
	MA. 79 Circuit Alterations	A-1
	Component Layout Diagrams	A-2
	Components List	A-3 & 4

ILLUSTRATIONS

		<u>Fig.</u>
	Block Diagram MA. 79H	A-1
	Circuit: Mixer Stage MA. 284	A-2
	Component Layout MA. 284	A-3
	MA. 79H Circuit: Modulation and I. F. Stages	A-4
	MA. 79H Circuit: Calibration and Output Stages	A-5

TECHNICAL SPECIFICATION

FREQUENCY RANGE: 1.5 Mc/s to 30 Mc/s

FREQUENCY DETERMINATION: (a) Six crystal controlled channels
(b) Continuous tuning calibrated at each kc/s with vernier adjustment 500-0-500 c/s
(c) External high-stability source, range, 3.6-4.6 Mc/s, level 2V

FREQUENCY STABILITY: VFO: 1.5-30 Mc/s:- better than ± 250 c/s.
Crystal: 1.5-5 Mc/s:- better than 5 parts in 10^6 , above 5 Mc/s:- better than 2 parts in 10^6

OUTPUT LEVEL: R.F.: 100 mW in to 75 ohms

INPUT FREQUENCY: Audio: 300-3,500 c/s, ± 2 dB
Keyed: 1,000 c/s

INPUT LEVEL: A.F.: $+10$ dBm to -20 dBm

INPUT IMPEDANCE: A.F.: 600 ohms balanced

F.S.K. or C.W. KEYING: Polar: 20-0-20V minimum
Neutral: -20 V minimum
Contact Closure: Maximum loop resistance 1500 ohms

CARRIER SHIFT (FSK): Adjustable 100-1,000 c/s

CARRIER REINSERTION: Continuously variable from -26 dB to -6 dB

Tech. Spec.

CARRIER SUPPRESSION:

S.S.B. : -50 dB
D.S.B. : -30 dB

DISTORTION:

Total Harmonic Content: -40 dB
Two Tone Test: -40 dB referred to the level of either tone
Unwanted Sideband Suppression: -48 dB
Noise and Hum: -45 dB
Other Spurious Output: -50 dB

METERING:

(a): R.F. Output
(b): F.S.K. - V.F.O. Calibration

TYPES OF EMISSION:

Telephony: Suppressed, reduce or full carrier with selection of upper, lower or double sideband
Telegraphy: F.S.K. or C.W. On/Off keying speeds up to 200 bauds

CALIBRATION:

Crystal checkpoints every 10 kc/s

FREQUENCY SETTING
ACCURACY:

V.F.O.: ± 250 c/s ± 1 part in 10^6 .

SUPPLY VOLTAGE:

100 - 125V and 200 - 250V and 45 - 60 c/s single phase a.c. 150VA approx.

DIMENSIONS AND WEIGHT:

Height	Width	Depth	Weight
10.5 in.	19 in.	21.3 in.	60 lb.
26.7 cm.	48.3 cm.	54 cm.	27.2 kg.

CHAPTER 1

INTRODUCTION

General Description

1. The MA. 79 Universal Drive Unit is a low level high-stability exciter source to drive a TA. 99 Linear Amplifier or similar power amplifier stages of other transmitter systems.
2. Two forms of the Drive Unit will be described viz. MA. 79A and MA. 79G. Throughout the following chapters, the MA. 79G will be emphasised, since the MA. 79A differs only in the exclusion of the facility for employing an external audio frequency modulator instead of the internal modulator. Hence, physically, the MA. 79A is not fitted with the two plugs and an extra switch position needed for this facility. Appropriately placed references to this difference will appear on illustrations and in the text.
3. The Drive Unit is continuously tuneable over the range 1.5 to 30 Mc/s and has the additional facility of six switched crystal-controlled frequency channels; to provide improved frequency stability, the unit can be operated in conjunction with an external synthesizer. The frequency generating circuit follows the principle of the Wadley system using 1 Mc/s temperature-controlled crystal oscillator.
4. Facilities are provided in the unit for generation of s. s. b. (upper or lower) signals with suppressed, reduced, or full carrier levels, i. s. b. telephony with an external modulator, f. s. k. transmission with a wide range of shifts, and for c. w. and m. c. w. keying. Where modulated i. s. b., s. s. b. or d. s. b. signals are concerned, the associated transmitter power amplification must be linear; for f. s. k. and c. w., Class B and Class C stages are acceptable.
5. Modulation facilities also allow the generation of compatible a. m. signals by selection of a sideband with full carrier re-insertion.
6. Frequency shift keying is provided at speeds up to 200 bauds, which ensures that all modern teleprinter outputs can be accepted, including the majority of the multiplex systems. The degree of shift is continuously variable to correspond with any narrow or wideband system. Keying may be either polar as with c. w., or by contact closure. Additionally, hand-speed c. w. operation may be used.

Mechanical Description

7. The MA. 79 is constructed on a cast aluminium chassis to ensure maximum mechanical stability. The chassis also provides means of electrically screening the separate r. f. circuits, in this unit, from each other. The bottom cover plate, left-hand sideplate and front panel are all removable to provide access to components and sub-chassis.

8. Three sub-chassis are mounted on the main chassis viz:

Mc/s Variable Frequency Oscillator

Kc/s Variable Frequency Oscillator

Modulation

The heater and h. t. supplies for all stages are derived from the main chassis. The relative positions of these sub-chassis are illustrated in figure 7.

9. A tool kit is provided on a clip board mounted on the right-hand side plate. The tools contained in the kit are detailed in Section 2, Chapter 5. These tools should be sufficient to carry out most servicing procedures required on this unit.

CHAPTER 2

OPERATING INSTRUCTIONS

NOTE: The MA.79 Drive Unit is a component unit of Transmitter TA.127, and Transmitting Terminals TTA.339 and TTA.371. This Chapter contains instructions for the Drive Unit only, and for complete instructions for the relevant transmitter reference should be made to Part 1, Section 1, Chapter 4 of the TA.127 handbook, Chapter 4 of the TTA.339 handbook and Chapter 4 of the TTA.371 handbook (A.P.116E-0257-1).

INSTALLATION

1. If channel crystal control is required, instal the crystals for the 6 channels as follows:-
 - (1) Remove the two knurled securing screws and the oven cover (fig. 7 - Oven 1).
 - (2) Fit the selected crystals inside the oven (fig. 13). It is recommended that the crystal frequencies are recorded against the appropriate channel (1 to 6) of the XTAL - V.F.O. switch (see paras. 2 and 3).

Determination of Channel Crystal Frequencies

2. The following formula ascertains the channel crystal frequencies corresponding to the 'kilocycles' content of the required r.f. output from the unit. If the 'kilocycles' part of the r.f. output is to be synthesised from an external source (XTAL - V.F.O. switch to EXT.), the range of the source must be 3.6 to 4.6 Mc/s; the formula can again be used for the same purpose
3. Channel crystal frequency (or external source frequency) = 4600 kc/s minus 'kilocycles' part of r.f. output (or carrier frequency); e.g. for a radiated frequency of 6.408 Mc/s, crystal frequency equals 4600 kc/s minus 408 kc/s viz. 4192 kc/s.

SETTING-UP

Switching On

4. (1) Set the voltage-selector plugs, on the rear of the unit, to suit the available power supply.
- (2) Join pin 3 to 4 and pin 5 to 6 on PL15.

- (3) Connect a 75 ohm, $\frac{1}{4}$ W resistor to PL2 (R. F. OUTPUT) on the rear.
- (4) Set the POWER switch to ON.
- (5) Assuming an ambient temperature in the range 21°C to 25°C, the approximate warming-up periods are as follows:
 - (a) For channel crystal control, fifteen (15) minutes, or
 - (b) For internal v. f. o. control, sixty (60) minutes.

Crystal Fine Tuning - Channel Crystal Control

6. Having determined the frequencies of the crystals to be used (para. 3), the frequency of each channel can be 'pulled' to the precise value required by making an adjustment to the associated crystal trimming capacitor (C1 to C6 of Table 1).

7. A Frequency Counter which can measure up to 3 Mc/s is required. Whatever the final r. f. output frequencies required from the unit, this procedure can be carried out at one setting only of the MEGACYCLES control.

- (1) Connect the Frequency Counter across the 75 - ohm resistor at PL2.
- (2) Calibrate the unit in accordance with para. 8.
- (3) Check that the METER switch is set to R. F. LEVEL, and the CALIBRATE switch to OFF.
- (4) Set the TRANSMISSION SELECTOR switch to C. W.
- (5) Set the SIDEBAND switch to DOUBLE.
- (6) Set the INPUT switch to SPACE.
- (7) Set the GAIN switch to MANUAL.
- (8) Set the OUTPUT RANGE MC/S switch to 1.5 - 3.
- (9) Set the MC/S scale to 2.
- (10) Set the XTAL - V. F. O. switch to Channel 1.
- (11) Advance the R. F. GAIN control until a small deflection is observed on the meter.
- (12) Adjust the OUTPUT TUNING and MEGACYCLES controls for a maximum meter indication, and at the same time, reset the R. F.

GAIN control for a final meter indication of 0 dB.

- (13) Adjust trimmer C6 (Table 1) until the counter displays the 'kilocycles' content of the required r. f. output.
- (14) Repeat operations (10) to (13) for each of the remaining channels 2 to 6; refer to Table 1.
- (15) The second v. f. o. is now accurately set for crystal operation. Set the INPUT switch to MARK and disconnect the counter and 75 ohm resistor.

CAUTION: The INPUT switch must not be set to any position other than MARK until PL2 has been correctly loaded.

TABLE 1

Channel No.	Crystal Ref.	Trimmer Ref.
1	XL1	C6
2	XL2	C5
3	XL6	C4
4	XL5	C3
5	XL4	C2
6	XL3	C1

Calibration of 1.6 Mc/s

8. (1) Set the CALIBRATE switch on the Drive Unit to 1.6 MC/S.
- (2) Set the METER switch on the Drive Unit to CALIBRATE.
- (3) Set the XTAL V. F. O. switch to any one of positions 1 to 6 on the Drive Unit.
- (4) Plug high-resistance headphones into the PHONES jack socket on the Drive Unit.
- (5) Remove the cap from the FINE FREQUENCY control of the Drive Unit.
- (6) Carefully adjust the preset FINE FREQUENCY control until a zero beat note is heard in the headphones; this will coincide with a zero beat indication on the meter. The zero (0) scale division should be approximately central with respect to the scale aperture.

Setting-Up Audio Input Level

NOTE: An r. f. Level indication on the meter of 0dB represents an r. f. output of 100 mW when the R.F. OUTPUT plug PL2 is terminated with 75 ohms.

10. (1) Connect the audio input to pin 9 and 10 of PL15.
- (2) Tune the Drive Unit to the required frequency and for c. w. operation (see para. 18).
- (3) Adjust the R.F. GAIN control for an r. f. level indication of 0dB.
- (4) Set the TRANSMISSION SELECTOR switch to SUPP.
- (5) Unscrew the cover and adjust the preset A.F. GAIN control to again give an r. f. level indication of 0dB. Replace the cover.

NOTE: When setting the audio levels for i. s. b. operation, reference must be made to the appendix covering Multi-Channel Operation of I.S.B. Transmitters, incorporated in the relevant transmitter system handbook.

Setting-Up Carrier Levels

11. (1) Tune the Drive Unit to any frequency and for c. w. operation (para. 18).
- (2) Adjust the R.F. GAIN control for an r. f. level indication of 0dB on the meter.
- (3) For A2, A3, or A3H emission, set the TRANSMISSION SELECTOR switch to PILOT and adjust the preset carrier re-insertion control C - on the front panel - until the meter indication is -6dB.
- (4) For A3A emission, set the TRANSMISSION SELECTOR switch to PILOT and adjust the preset carrier re-insertion control C for a meter indication in the range of -6dB to -26dB as required; for levels below -14dB, the +14dB push-button must be operated and the reading taken from the lower meter scale.

Setting-Up Frequency Deviation

12. (1) Tune the Drive Unit to the required frequency and for c. w. operation (para. 18).
- (2) Adjust the R.F. GAIN control for an r. f. level indication of 0dB on the meter.
- (3) Calibrate in accordance with paragraph 8.

NOTE: It is not necessary to re-calibrate if the procedure of para. 8 has already been carried out.

- (4) Set the TRANSMISSION SELECTOR switch to F.S.K.
- (5) Set the CALIBRATE switch to 1.6 Mc/s.
- (6) Set the METER switch to CALIBRATE.
- (7) Set the INPUT switch to MARK.
- (8) Remove the cap and turn the preset FINE FREQUENCY control in the counter-clockwise direction until the desired 'mark' shift frequency on the dial coincides with the cursor.
- (9) Adjust the preset 'mark' control M - on the front panel - until a zero-beat indication is shown on the meter.
- (10) Set the INPUT switch to SPACE.
- (11) Turn the FINE FREQUENCY control in a clockwise direction until the desired 'space' shift frequency on the dial coincides with the cursor.
- (12) Adjust the preset 'space' control S until a zero-beat indication is shown on the meter.
- (13) Since the effects of the M and S controls are interdependent, operations (8) to (12) should be repeated until the required result is obtained.
- (14) Return METER switch to R.F. LEVEL, the CALIBRATE switch to OFF, the FINE FREQUENCY control to zero on the scale and fit the cap.

Additional Facilities

13. The Distortion Test Input connections (pins 11 and 12 of PL15) are used in conjunction with the Racal Distortion Measuring Unit Type MA.141.
14. When the SIDEBAND switch on the MA.79G or H is set to EXT, an external audio modulator (S.S.B. or I.S.B.) is required. The modulator used must be designed to accept a 1.4 Mc/s source for modulation purposes, and this source is available, on the rear of the Drive Unit, at plug PL20 (1.4 Mc/s OUTPUT); the modulated 1.4 Mc/s from the external modulator is applied to plug PL17 (1.4 Mc/s INPUT). The Racal I.S.B. Modulators Type MA.175 and MA.202 are available for this purpose. The MA.79D has no internal audio modulation facilities and hence no SIDEBAND switch, but the above plugs are provided for the same purpose.

15. If the 'kilocycles' content of the r.f. output from the unit is to be synthesised from an external source, this is applied to plug PL14 and the XTAL V.F.O. switch is set to EXT. In this case, the instructions of para.9 are not applicable.

OPERATING INSTRUCTIONS

16. Ensure that the appropriate warming-up periods (see para.5) are observed. Paragraphs 17 to 24 assume that the procedures in paragraphs 1 to 15 have where applicable, been carried out.

Tuning Procedure for A1 Emission.

17. Make connections to the keying input line as follows:

- (a) For teleprinter input, connect pin 3 to 4 and pin 5 to 6 on PL15; connect the 80 - 0 - 80 keying lines between pins 1 and 5 of PL15.
- (b) For contact-off c.w. keying, connect pin 3 to 4 and pin 5 to 6 on PL15; connect the key between pins 1 and 3 of PL15.
- (c) For contact-on c.w. keying, connect pin 3 to 4 and pin 5 to 6 on PL25; connect a 6.8k, $\frac{1}{4}$ W resistor between pins 1 and 3 of PL15; connect the key between pins 1 and 5 of PL15.

18. (1) Set the XTAL-V.F.O. switch to:-

- (a) Any of positions 1 to 6 for channel crystal control, or
- (b) EXT when an external source such as a crystal-controlled oscillator or synthesiser is used, or
- (c) V.F.O. for internal v.f.o. control.

(2) Set the GAIN switch to MANUAL.

(3) Set the INPUT switch to SPACE and the SIDEBAND switch to DOUBLE.

(4) Set the TRANSMISSION SELECTOR switch to C.W.

(5) Set the R.F. GAIN control fully clockwise.

(6) Set the MC/S scale to the required setting using the MEGACYCLES control.

- (8) Set the OUTPUT RANGE MC/S switch to the appropriate position.
- (9) Carefully adjust the OUTPUT TUNING control to produce a maximum r. f. level indication on the meter; while doing this, reduce the setting of the R. F. GAIN control to avoid damage to the meter. Finally, adjust the MEGACYCLES control for a maximum meter indication.
- (10) Adjust the R. F. GAIN control for a meter indication of 0 dB.
- (11) Set the TRANSMISSION SELECTOR switch as follows:-
 - (a) to PILOT for A2, A3, A3A or A3H emission, or
 - (b) to SUPP for A3J emission.
- (12) Set the SIDEBAND switch as follows:-
 - (a) to DOUBLE for A2 or A3 emission, or
 - (b) to U.S.B. or L.S.B. for A2, A3A, A3H or A3J emission, or
 - (c) to EXT (MA. 79G & H only) for using an external s. s. b. or i. s. b. modulator (refer to para. 14).

NOTE: Operation (12) is not applicable in the case of the MA. 79D (see para. 14).

- (13) Check that the preset carrier re-insertion control has been adjusted in accordance with para. 11.
 - (14) Set the INPUT switch to OPERATE.
22. Final adjustments to the gain of the Drive Unit, and the manner in which it is performed, depend on the type of Linear Amplifier being driven by this unit.

Tuning Procedure for F1 Emission

23. Making connections to the keying input line as follows:-
- (a) For teleprinter input, connect pin 3 to 4 and pin 5 to 6 on PL15; connect the 80 - 0 - 80 keying lines between pins 1 and 5 of PL15.
 - (b) For contact-off c. w. keying, connect pin 3 to 4 and pin 5 to 6 on PL15; connect the key between pins 1 and 3 of PL15.

CHAPTER 3

PRINCIPLES OF OPERATION

Introduction

1. To simplify the description of the operating principles of the MA. 79 Universal Drive Unit, the circuit is considered in the simplified form shown below.

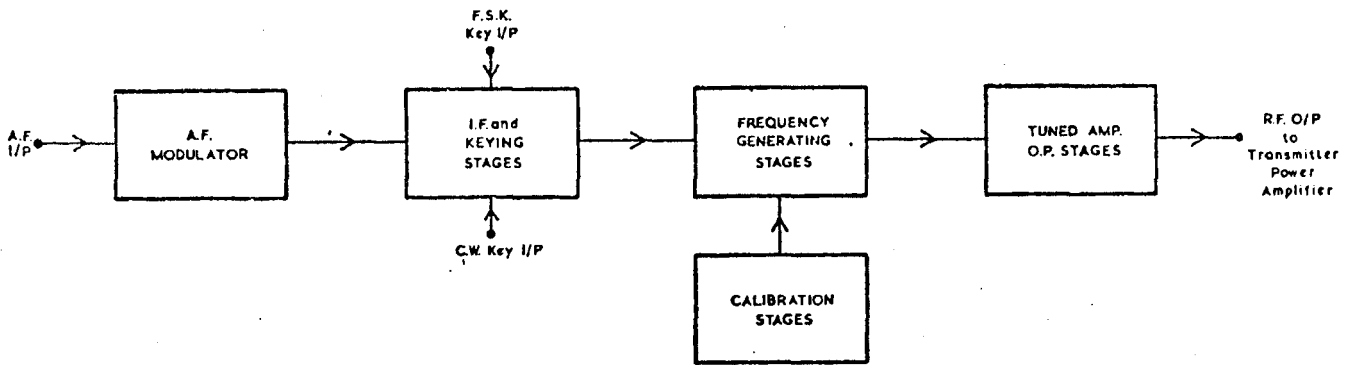

MA.79-SIMPLIFIED BLOCK DIAGRAM

2. The principles on which the a. f. modulator and tuned output stages operate are conventional (Chap. 4). The i. f. and keying stages operate on a triple conversion system which simplifies f. s. k. operation of the Drive Unit. The remaining stages i. e. frequency generating and calibration are those which are described in the following text.

FREQUENCY GENERATING STAGES

Preliminary

3. The high degree of accuracy and range of frequencies required to operate an s. s. b. transmitter are difficult to obtain by conventional means. If an inductance / capacitance oscillator is used, complex compensating circuitry would be required to provide the necessary accuracy and stability. Alternatively, if crystal oscillator(s) were utilized either the number required would be prodigious on the frequency changing system complex. This problem has been overcome in the MA. 79 Universal Drive Unit by means of the Wadley system of tuning.

Wadley System

4. The system is named after the author of a paper published in Trans. S. A.

1. E. E. Feb. 1954. It operates by heterodyning a series of harmonics generated from a fundamental crystal oscillator with the output of a variable frequency oscillator; selection of the required frequency being made by means of a narrow band-pass filter.

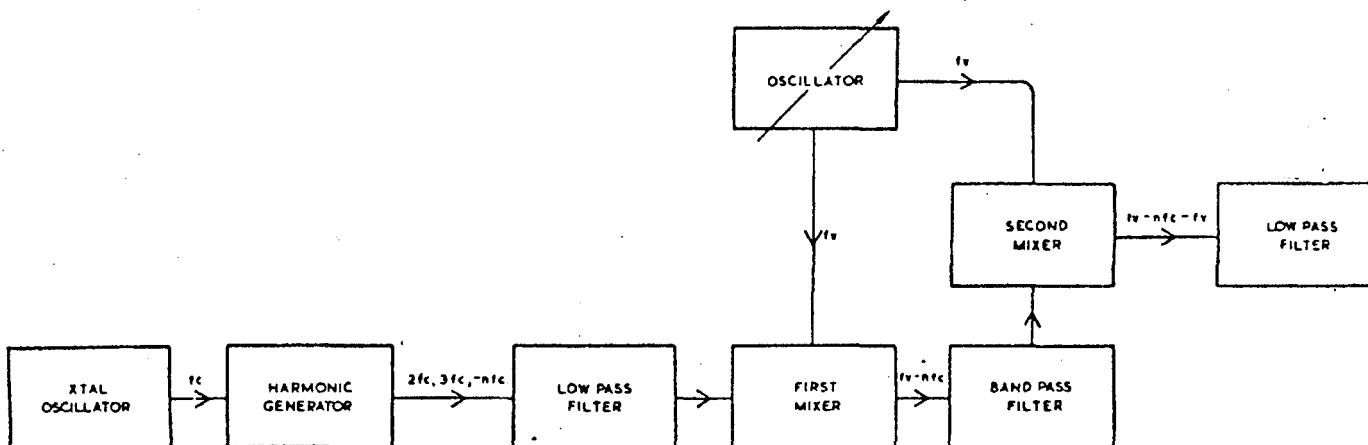

WADLEY TUNING SYSTEM-SIMPLIFIED BLOCK DIAGRAM

5. The diagram of the Wadley system shows that the output of the crystal oscillator, f_c , is fed to a harmonic generator which produces the harmonics $f_c, 2f_c, 3f_c, \dots, nf_c$. This output is then passed through a low-pass filter, which determines the maximum output frequency of the system, and then to the first mixer stage. The generated harmonics are mixed with the output of variable oscillator, f_v , thus producing the sum and difference frequencies of $f_c + f_v$ and $f_c - f_v$ etc.

6. The output of the 1st mixer stage is then fed through a band-pass filter the bandwidth of which is such that only one of the mixer output frequencies is passed. The selected frequency, $f_v - nf_c$ is again mixed with f_v , thus reducing the signal to the original harmonic nf_c . To ensure that only the harmonic frequency appears in the output, another low-pass filter determines the maximum output frequency.

7. If the system is now considered as a whole it will be apparent that the frequency of output may be varied, in steps equal to f_c , by altering the frequency of the variable oscillator. It will also be apparent that the accuracy of this frequency will be almost as high as that of the original crystal oscillator and, provided suitable frequencies are selected, drift of the variable frequency oscillator will not affect the output.

Electronic Bandswitching

8. Since the basic Wadley system produces only multiples of f_c , it is modified to produce the required continuous range of frequencies.

9. The major modification to the system is the introduction of mixer and filter stages to facilitate the insertion of the modulated 2-3 Mc/s signal from the kilocycles variable frequency oscillator. The fact that the modulated signal is in the range 2-3 Mc/s also necessitates raising of the first low-pass filter pass frequency 2 Mc/s above the maximum output frequency. The addition of the tuned amplifier after the first mixing stage is only a refinement of the circuit and does not basically alter the operation of the system.

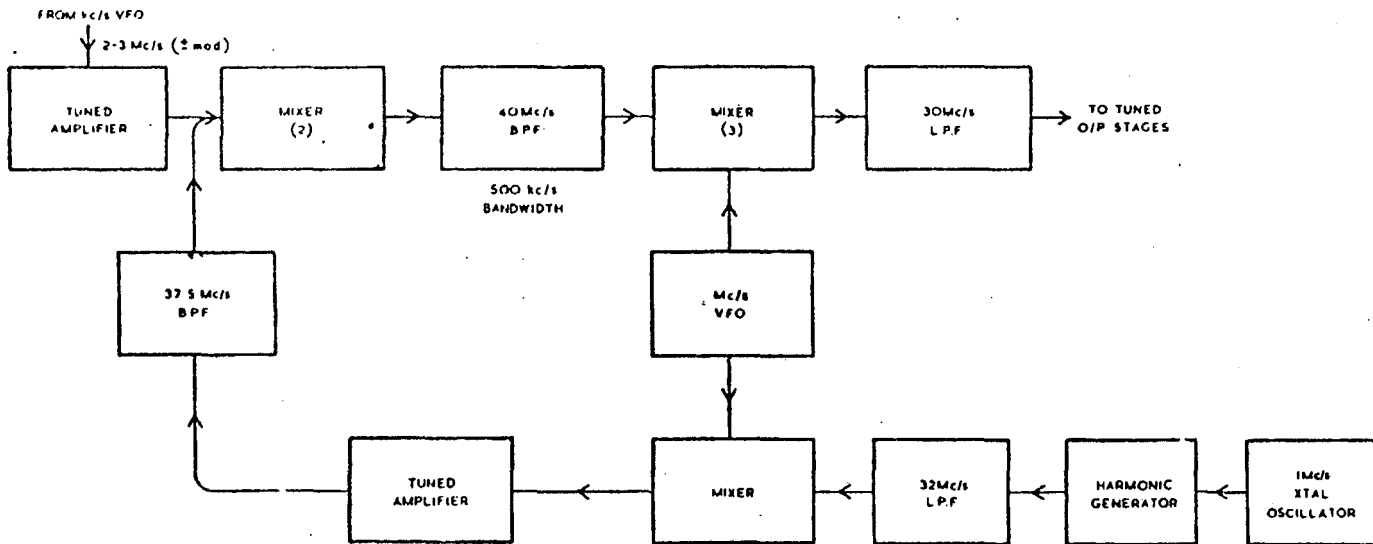

MA.79 ELECTRONIC BANDSWITCHING-BLOCK DIAGRAM

CALIBRATION STAGES

Preliminary

10. The function of the calibration stages is to provide a means of checking the frequency accuracy of the Drive Unit. This is achieved by producing check signals from the 1 Mc/s crystal oscillator used in the electronic bandswitching system, and beating it with the output signals in the conventional manner.

11. The system consists of two similar stages which produce 100 kc/s and 10 kc/s outputs by means of regenerative division of the basic 1 Mc/s signal. When selected the appropriate signal beats with the output frequency and the resultant output may be monitored aurally by 'phones or visually on the signal meter.

Regenerative Dividing

12. This method of frequency dividing provides a high degree of accuracy.

CHAPTER 4

CIRCUIT DESCRIPTION

Introduction

1. The following text describes the Drive Unit circuit under two main headings - viz:-

SIGNAL FLOW - Outlining the relationship between stages

and

STAGE DESCRIPTIONS - Describing stage operation.

Continuity between these sub-divisions is established by describing the stages in signal flow sequence. Stages which are not directly concerned with signal flow are described separately as ancillary stages.

2. For simplicity in the descriptions, it has been assumed that the user is familiar with the conventional circuitry used in s.s.b. transmitters. Alternatively, the user should have access to suitable reference books. The preceding Chapter, Principles of Operation, provides details of the less conventional stages and systems used in the MA.79 Universal Drive Unit.

SIGNAL FLOW

General

3. Signal flow in the MA.79 Universal Drive Unit may readily be traced on the Block Diagram of the unit, Fig. 1. The following description is, therefore, directly referenced to this illustration.

S.S.B./D.S.B. - Internal Modulation

4. Selection of the internal modulator for s.s.b./d.s.b. mode of emission is made by setting the appropriate switches as follows:-

(SUPP. for suppressed carrier level,
(i.e. more than -50dB down on signal.
TRANSMISSION selector, SB, to (
(PILOT for carrier level between -6dB
(and -26dB down on signal.

	(UPPER for upper sideband emission.
	(
SIDEBAND selector, SE, to	(DOUBLE for double sideband emission.
	(
	(LOWER for lower sideband emission.
INPUT selector, SC, to	(AUDIO for distortion test audio input (channel.
	(OPERATE for normal a.f. input channel.
CALIBRATE switch, SJ, to	OFF for any mode of operation.
METER switch, SH, to	R.F. LEVEL for any mode of operation.

NOTE: The operation of switches SH and SJ is fully described in Chapter 2.

5. When the circuit has been set up for the required mode of s.s.b. emission, a.f. signals are fed into the circuit via the A.F. INPUT or the DISTORTION TEST INPUT. These input signals are then applied, via switch SC, to the cathode follower and thence to the balanced modulator. The audio signals modulate the 1.4 Mc/s i.f. to produce both the upper and lower sidebands with the carrier suppressed. The required sideband (s) is then obtained via the sideband selection circuit which consists of the switch, SE, and the three sideband filters.

6. The selected sideband signal is applied to the automatic level control stage and passed to the 11.6 Mc/s mixer, mixer 5. In addition to the selected sideband, the signal applied to mixer 5 will embody the 1.4 Mc/s i.f. at the required level for carrier re-insertion. This composite signal is mixed with the 10.2 Mc/s output of the 5.1 Mc/s Oscillator and Doubler to produce the second i.f. of 11.6 Mc/s sideband (s). This second i.f. is applied to the 1.6 Mc/s mixer, mixer 4, where it is heterodyned with the 10 Mc/s output of the 5 Mc/s oscillator and doubler, producing the final i.f. of 1.6 Mc/s sideband(s).

7. The 1.6 Mc/s signal then passes, via the c.w. keyer, to mixer 1 where it is mixed with the 3.6 - 4.6 Mc/s output of the kc/s v.f.o. to produce the 2-3 Mc/s signal for injection into the electronic bandswitching stages, only two of which are concerned with the main signal flow. These stages, mixers 2 and 3, convert the 2-3 Mc/s output of mixer 1 into the selected transmission frequency. This signal is then fed through the tuned amplifiers to provide the excitation for a power amplifier unit.

NOTE: The relationship between the electronic band-switching stages is explained in the preceding Chapter, Principles of Operation.

CHAPTER 2

DISMANTLING AND RE-ASSEMBLY

Introduction

1. The Universal Drive Unit type MA. 79 is comprised of the following sub-units:-
 - (1) Front Panel, containing:
 - (a) Tuning Escutcheon
 - (b) Fine Frequency Control
 - (c) R. F. Level/Calibrate Meter
 - (2) Kc/s V.F.O. Sub-chassis, containing:
 - (a) 3.6 - 4.6 Mc/s V.F.O. (V4, V7)
 - (b) Oven/Control Relay (RLA)
 - (3) Mc/s V.F.O. Sub-chassis, containing:
 - (a) 40.5 - 69.5 Mc/s V.F.O. (V23)
 - (b) Mixer 3 (V20)
 - (c) 30 Mc/s Low Pass Filter
 - (d) Tuned Amplifiers (V26, V30)
 - (4) Modulation Sub-chassis, containing:
 - (a) 5 Mc/s Crystal Oven (Oven 3)
 - (b) Variable Reactance Valve (V2)
 - (c) 5 Mc/s Crystal Oscillator (V5)
 - (d) 5.1 Mc/s Crystal Oscillator (V19)
 - (e) Automatic Level Control Stage (V22)
 - (f) Mixer 5 (V25)

- (g) Mixer 4 (V8)
 - (h) C.W. Keyer (V12)
 - (j) Mixer 1 (V10)
 - (k) Keying Test Source (V16)
 - (l) 1.4 Mc/s Amplifier (V9)
 - (m) Cathode Follower (V6)
 - (n) Balanced Modulator (V13)
 - (o) 2 - 3 Mc/s Band Pass Filter
- (5) Main Chassis, containing:
- (a) Mixer 2 (V14)
 - (b) Amplifier (V17)
 - (c) 1 Mc/s Crystal Oscillator (V1)
 - (d) Harmonic Generator (V3)
 - (e) Harmonic Filter
 - (f) Harmonic Mixer (V11)
 - (g) Harmonic Amplifier (V15, V18)
 - (h) 37.5 Mc/s Band Pass Filter
 - (j) 40 Mc/s Band Pass Filter
 - (k) 100 Kc/s Divider (V27, V28)
 - (l) 100 Kc/s Multiplier (V31)
 - (m) 10 Kc/s Divider (V21, V24)
 - (n) Harmonic Amplifier (V29)
 - (o) Calibration Mixer (V33)
 - (p) Audio Amplifier (V32)

Dismantling

2. Before any of the operations detailed in the following paragraphs the Drive Unit should be removed from the transmitter cabinet as detailed Part 1, Section 2, Chapter 2.

3. Front Panel

- (a) Remove all control knobs.
- (b) Disconnect the meter leads noting colour code/position.
- (c) Remove securing nuts from R.F. LEVEL/CALIBRATE and 14dB switches.
- (d) Extract the panel retaining screws.
- (e) Remove front panel.

4. Kc/s V.F.O. Sub-Chassis:

- (a) Remove all bottom cover plate from unit.
- (b) Disconnect the soldered connections from the 4-way connector block near R161.(Fig.9) noting colour codes/positions.
- (c) Disconnect relay and heater leads from terminals adjacent to RLA (Fig. 7) noting colour code/positions.
- (d) Remove cable cleats securing dial lamp leads and unclip lamp-holders.
- (e) Disconnect the coaxial plugs/sockets from SKT3, SKT4, SKT5 and PL13 (Fig. 7)
- (f) Remove front panel as detailed in para. 3.
- (g) Remove MEGACYCLES dial from its boss.

CAUTION: Do not remove the boss from its shaft.

- (h) Extract the two retaining screws adjacent to C6 and L8 (Fig. 7)
- (j) Lift out kc/s v.f.o. sub-chassis.

5. Mc/s V.F.O. Sub-chassis: It is desirable, but not essential, that the kc/s v.f.o. sub-chassis is removed (para.4) before the Mc/s v.f.o. sub-

chassis. The procedure detailed below describes removal with kc/s v.f.o. sub-chassis still in position,

- (a) Remove bottom cover plate from unit.
- (b) Disconnect soldered connections from 4-way terminal block near R182 (Fig. 8) noting colour codes/positions.
- (c) Disconnect screened lead from C298 which is adjacent to C296 (Fig. 8).
- (d) Disconnect orange lead from the junction of R112/C124 (Fig. 8).
- (e) Disconnect coaxial plugs/sockets from SK5, SK12 and PL13 (Fig. 7).
- (f) Remove valves V24, V32 and V33 from their sockets.
- (g) Remove tool clip-board from right-hand-side panel above chassis.
- (h) Remove front panel as detailed in para. 3.
- (j) Extract the three retaining screws from the top of the sub-chassis.
- (k) Lift out Mc/s v.f.o. sub-chassis.

6. Modulation Sub-chassis: All components on this sub-chassis are accessible when left-hand side panel of drive unit is removed. Should it be necessary to remove sub-chassis proceed as follows:-

- (a) Remove left-hand side panel from drive unit.
- (b) Disconnect coaxial sockets from PL9, PL10, PL13, and PL18 (Fig. 7).
- (c) Disconnect soldered leads from multi-way connector strip near L4 (Fig. 8) noting colour codes/positions.
- (d) Remove knob and retaining nut from the INPUT SELECTOR switch.
- (e) Remove sub-chassis retaining screws.
- (f) Withdraw modulation sub-chassis.

Re-assembly

7. Modulation Sub-Chassis:

- (a) Insert sub-chassis into position (Fig. 7) and secure in position with retaining screws.
- (b) Solder leads to multi-way connector block in positions noted during dismantling.
- (c) Connect appropriate coaxial sockets to PL9, PL10, PL13 and PL18.
- (d) Secure INPUT SELECTOR switch with retaining nut and fit knob.
- (e) Replace and secure the drive units left-hand side panel.

8. Mc/s V.F.O. Sub-chassis:

- (a) Place sub-chassis in position (Fig. 7) and secure with the three retaining screws.
- (b) Replace front panel as detailed in para. 10.
- (c) Replace tool clip board to right-hand side panel above chassis.
- (d) Replace valves V24, V32, and V33 (Fig. 7).
- (e) Connect appropriate coaxial plugs/socket to SKT5, SKT12 and PL13 (Fig. 7).
- (f) Solder orange lead to junction of R112/C124 (Fig. 8).
- (g) Solder screened lead to C298 (Fig. 8).
- (h) Solder three leads to 4-way terminal block near R182 (Fig. 8), in positions noted during dismantling.
- (j) Replace and secure the drive units bottom cover plate.

9. Kc/s V.F.O. Sub-chassis:

- (a) Place sub-chassis in position (Fig. 7) and secure with two retaining screws.
- (b) Turn boss on MEGACYCLES control shaft fully counter-

clockwise.

- (c) Set engraved alignment mark on MEGACYCLES dial to '12 o'clock' position and fit dial to boss.
- (d) Replace front panel as detailed in para. 10.
- (e) Connect appropriate coaxial plugs/socket to SKT3, SKT4, SKT5 and PL13. (Fig. 7).
- (f) Replace dial lampholders and secure leads with cable cleats.
- (g) Solder relay and heater leads to terminals adjacent to RLA in positions noted during dismantling.
- (h) Solder three leads to 4-way connector block near R161 (Fig. 9) in positions noted during dismantling.
- (j) Replace drive units bottom cover plate.

10. Front Panel:

- (a) Place panel in position and secure with retaining screws.
- (b) Replace securing nuts on R. F. LEVEL/CALIBRATE and 14dB switches.
- (c) Reconnect meter leads in positions noted during dismantling.
- (d) Replace control knobs.

11. Replacement of Film Scale:

- (a) Rotate KILOCYCLES control until end stop beyond 1,000 kc/s is reached.
- (b) Remove front panel as detailed in para. 3.
- (c) Remove top plate and idler gear from drive gears ensuring that gears are not displaced during removal.
- (d) Allow drive gears to unwind slowly.
- (e) Remove the scale film.
- (f) Fit 1,000 kc/s end of new scale film to drive sprocket and wrap the end around the split pin on the left-hand bobbin.

11. Replacement of Film Scale: (cont'd)

- (g) Rotate left-hand bobbin clockwise until approximately $1\frac{1}{2}$ ft. of the film is left free.
- (h) Fit free end of film to the second and turn bobbin counter-clockwise until film is taut.
- (j) Turn drive gears in opposite directions approximately one revolution and fit idler gear while under tension.
- (k) Replace top plate and secure with retaining screws.
- (l) Set KC/S scale to mechanical end stop at 1,000 kc/s end and check that capacitor vanes are fully meshed on right of spindle as viewed from the front of the unit.
- (m) Check that distance between cursor and 1,000 kc/s end of scale is approximately $\frac{1}{2}$ in. If necessary correct distance by lifting film from drive sprocket and moving as required.
- (n) Replace front panel as detailed in para. 10.

12. Re-alignment of kc/s V.F.O.

- (a) Connect supplies to drive unit.
- (b) Set METER switch to CALIBRATE.
- (c) Set CALIBRATE switch to 100 KC/S.
- (d) Set KC/S cursor to mid position.
- (e) Set KC/S control to zero (0) and adjust C46 (Fig. 13) for zero beat.
- (f) Set KC/S control to 1,000 and adjust L14 (Fig. 13) for zero beat.
- (g) Repeat (e) and (f) until zero beat is obtained at both ends of scale.

13. Replacement of Tuning Capacitor: If the tuning capacitor, C47, is replaced re-align v. f. o. as detailed in para. 11 (l) and (m) and para. 12.

CHAPTER 3

ALIGNMENT PROCEDURES

Introduction

1. The information given in this chapter is intended to serve three purposes.
 - (a) To enable a check and, if necessary, adjustments to be made so that the performance conforms with the Technical Specification given in Section 1.
 - (b) Assist in detailed fault location.
 - (c) Provide information for adjustment of the FINE FREQUENCY preset control.

Test Equipment

2. The following items of test equipment are needed to carry out the alignment procedures. Throughout this chapter, test equipment will be called up by the item 'Letter' reference given in the following list, e.g. Item (e).

- (a) Audio signal generator, to following specification:

Frequency Range:	300 c/s to 10 kc/s $\pm 2\%$.
Output Level:	0.1mW to 1W (0.25V to 25V) continuously variable -2dB.
Output Impedance:	600-ohms.
Example Instrument:	Advance Components. Audio Signal Generator Type J1 or J2. (J.S. Cat. No. J1: 6625-99-943-4059).

- (b) R.F. Signal generator, to the following specification:

Frequency Range:	1.5 Mc/s to 25 Mc/s.
Calibration Accuracy:	$\pm 1\%$.
Output Level:	2.75 volts min.
Output Impedance:	75-ohms.
Example Instrument:	Marconi Instruments Signal Generator T.F. 867.

(c) Digital frequency meter to following specification:

Frequency Range: 20 c/s to 30 Mc/s.
Accuracy: ± 1 count ± 1 part in 10^6 .
Input Sensitivity: 10 mV r.m.s.
Input Impedance: 1 Megohm shunted by 15 pF.
Example Instruments: Racal Instruments Digital Frequency Meter 806R, SA. 540/550 fitted with Probe SA. 544 or SA. 505 and Oscilloscope Item (g).

(d) Valve voltmeter to the following specification:

A.C. Voltage Range: 0 to 1V, 3V, 10V and 300V $\pm 300 \pm 3\%$ f.s.d.
Input Impedance: 0-10 kc/s - 5 Megohms) Shunted
(approx.) 10 kc/s - 1 Mc/s - 2.7 Megohms) by
10 Mc/s - 100 Mc/s - 50 Kilohms) 4 pF
Example Instrument: Marconi Instruments Vacuum Tube Voltmeter T.F. 1300 with A.C. Multiplier T.M. 6067.

(e) Valve millivoltmeter to following specification:

A.C. Voltage Range: 0 to 1mV, 3mV, 10mV, 30mV, 100mV, 300mV, 1V and 3V.
Input Impedance: 1 kc/s - 1 Megohm, 30 Mc/s - 50 kilohms shunted by 7pF.
Example Instrument: Phillips Valve Millivoltmeter GM 6014.

(f) Two-tone oscillator to following specification:

Frequency Range: 20 c/s - 20 kc/s continuously variable independently.
Output Levels: 0.1 mW to 1W (0.25V to 25V) continuously variable.
Output Impedance: 600-ohms.
Example Instruments: Marconi Instruments Oscillator TF2005R.

(g) A good quality oscilloscope: Input Impedance of $1M\Omega + 20$ pF and 'Vertical Signal Out' facility.
Example Instrument: Tektronix Type 545.

(h) H.F. Spectrum Analyser to following specification:

Frequency Range: 1.5 Mc/s to 30 Mc/s.
Input Level: 100 mW min.
Input Impedance: 75Ω.
Amplitude Measurement Range: 0 to -60dB.
Example Instrument: Furzehill Laboratories H.F. Spectrum Analyser S510 with frequency changer S520.

(j) High impedance headphones.

(k) Wire Probe - Made by stripping back 3/8 in. of the insulation from each end of a 3½ in. length of 7/0076 wire.

(l) Resistor - 75 ohms, 10%, ¼W.

(m) Resistor - 1 kilohm, 10%, ¼W.

(n) Crystals, Type D.

Frequency Range: 3.6 - 4.6 Mc/s
as XL1 to XL6 Part 2, Section 2,
Chapter 5 (Parts List).

(o) Resistor - 100 ohms,
10%, ¼W.

Initial Procedure

3. (1) Withdraw the Drive Unit from the cabinet removing all rear connections before lifting out the unit.
- (2) Check that the primary taps on the mains transformer are adjusted to suit the available mains voltage.
- (3) Connect the 75-ohm resistor Item (l) between the R.F. OUTPUT plug PL2 and chassis.

NOTE: This resistor must be removed when connecting the Spectrum Analyser Set for 75Ω input impedance.

- (4) Connect together pin 3 and 4 of the 12-pin unitor PL15 (on rear of chassis).

- (5) Remove the dust cover from the unit.
- (6) Connect the mains supply voltage and switch on. Allow approximately one hour for the unit to warm up.
- (7) After the one hour warming up, disconnect SK6 (Fig. 7) and connect the Frequency Meter Item (c) between PL6 and earth.
- (8) Set the Frequency Meter to a minimum 1 second 'gate' time and check that the reading is 1 Mc/s ± 1 count.
- (9) Disconnect the Frequency Meter and reconnect SK6.

Kc/s V.F.O. Output

4. (1) Set the XTAL, V.F.O. switch to V.F.O.
- (2) Connect the Valve Voltmeter Item (d) between pin 2 of V10 valveholder and chassis.
- (3) Rotate the KILOCYCLES control from 0 to 1000 on the KC/S scale and check that the meter indication is within the limits 2.5 and 3.5 volts.
- (4) Remove the two knurled screws from the top of crystal oven 1, and take off the cover.
- (5) Fit six crystals, in the positions provided, in the frequency range of 3.6 to 4.6 Mc/s; refit the oven cover.
- (6) Set the XTAL, V.F.O. switch to each of the positions 1 to 6 in turn, and check that the meter indication is within the limits of 2.5 and 3.5 volts r.m.s.

2 to 3 Mc/s Filter Output

5. (1) Disconnect PL8 from SKT8.
- (2) Connect the 1 kilohm, $\frac{1}{4}$ W resistor Item (m) between SKT8 and chassis.
- (3) Connect the Valve Voltmeter Item (e) with input padded to a total of 12 pF, across the 1 kilohm resistor.
- (4) Set the XTAL, V.F.O. switch to V.F.O.

- (5) Set the TRANSMISSION SELECTOR switch to C.W. and the R.F. GAIN control fully clockwise.
- (6) Rotate the KILOCYCLES control from 0 to 1000 on the KC/S scale, and check that the meter indication is never less than 160 mV and that the maximum to minimum output does not exceed 3dB.
- (7) Remove the voltmeter and 1 kilohm resistor and reconnect PL8 to SKT8.

F.S.K. and Fine Frequency Calibration

6. (1) Set the XTAL/VFO switch to EXT. and on the MA.79H only set the IN/OUT switch on the MA.284 to OUT.
- (2) Fit a suitable crystal item (n) into any spare crystal position in oven 1 (Fig. 13).
- (3) With the FINE FREQUENCY cursor centred, check that when the calibration dot, which is 3/8 inch to the left of the extreme minus calibration marking on the scale, is lined up on the dial, capacitor C113 is at maximum capacity.
- (4) Set the TRANSMISSION SELECTOR to FSK and the INPUT switch to SPACE.
- (5) Set preset capacitor S (C12) to maximum capacity and preset capacitor M (C19) to minimum capacity.

NOTE: If the bottom cover of the equipment is removed these capacitors can be seen beneath the side cover without the need to remove this cover.

- (6) Remove V8 and fit one end of the wire probe Item (k) into Pin 1 position on the valveholder. Replace V8 and its screening can, and feeding the wire probe between the valve and the screening can at the same time so that the free end of the probe protrudes out of the top of the screening can.
- (7) Connect the Frequency Meter Item (c) between the free end of the wire probe Item (k) and the chassis. Tune L6 until a reading 9 996 000 c/s \pm 5 c/s is indicated on the Frequency Meter.

- (8) By progressive adjustments of capacitors S and M, when switching the INPUT switch alternatively between SPACE and MARK ensure the conditions given below can be met.

<u>INPUT SWITCH</u>	<u>FREQUENCY METER</u>
SPACE	9 996 450 c/s ± 2 c/s
MARK	9 996 550 c/s ± 2 c/s

NOTE: A slight re-adjustment of L6 may be required to obtain the above figures.

- (9) By progressive adjustments of capacitors S and M, when switching the INPUT switch alternatively between SPACE and MARK until the conditions given below can be met.

<u>INPUT SWITCH</u>	<u>FREQUENCY METER</u>
SPACE	9 996 000 c/s ± 2 c/s
MARK	9 997 000 c/s ± 2 c/s

NOTE: A slight re-adjustment of L6 may be required to obtain the above figures.

- (10) Set the TRANSMISSION SELECTOR to C.W. the INPUT switch to SPACE and adjust capacitor C15 for a Frequency Meter indication of 9 996 500 c/s ± 1 c/s.
- (11) Disconnect the Frequency Meter and wire probe from valve V8 and fit the wire probe to pin 2 of valveholder for V10 in the same manner as described in operation (6).
- (12) Connect the Frequency Meter between the free end of the wire probe and chassis.
- (13) Set the R.F. GAIN control fully clockwise and centre the FINE FREQUENCY cursor.
- (14) Set the FINE FREQUENCY dial to -500 c/s and adjust the core of L24 (see fig. 7) to obtain a reading of 1 599 500 c/s ± 10 c/s on the Frequency Meter.
- (15) Set the FINE FREQUENCY dial to +500 c/s and adjust preset capacitor C112 (see Fig. 7) to obtain a reading of 1 600 500 c/s ± 10 c/s on the Frequency Meter.

- (16) Continue to adjust L24 and C112 until the dial settings and Frequency Meter readings given below are obtained.

<u>DIAL SETTING</u>	<u>FREQUENCY METER</u>
+500	1 600 500 c/s ± 10 c/s
+400	1 600 400 c/s ± 10 c/s
+300	1 600 300 c/s ± 10 c/s
+200	1 600 200 c/s ± 10 c/s
+100	1 600 100 c/s ± 10 c/s
0	1 600 000 c/s ± 2 c/s
-100	1 599 900 c/s ± 10 c/s
-200	1 599 800 c/s ± 10 c/s
-300	1 599 700 c/s ± 10 c/s
-400	1 599 600 c/s ± 10 c/s
-500	1 599 500 c/s ± 10 c/s

- (17) Disconnect the wire probe and Frequency Meter.

NOTE: The wire probe and an oscilloscope pre-amplifier are not required for remaining operations in this paragraph.

- (18) Set the FINE TUNING dial to 0 and check that the INPUT switch is in the SPACE position.
- (19) Select the 1.6 Mc/s position on the CALIBRATE switch and CALIBRATE on the METER switch. The meter should indicate zero beat. A slight re-adjustment of C15 may be necessary to obtain zero beat.
- (20) Set the R.F. GAIN control to its mid-rotation position and connect the Frequency Meter across the 75 ohm resistor on PL2.
- (21) Select the appropriate position on the XTAL/VFO switch for the position of the crystal inserted in operation (2) and tune the MA.79 for C.W. operation as given in the Operating Instructions.
- (22) Adjust the trimmer capacitor associated with the crystal to obtain the output signal calculated, see Section 1, Chapter 2, Paragraph 2 and 3.
- (23) Adjust the FINE FREQUENCY control from 0 to -500 c/s and 0 to +500 c/s in 100 c/s steps and check that Frequency Meter indicates shifts of 100 c/s ± 10 c/s.

- (24) Reset the FINE FREQUENCY control to 0 and check that the Frequency Meter indication is within ± 2 c/s of the reading obtained in operation (22).
- (25) Set the MA.79 up for FSK operation as given in the Operating Instructions and check that shifts of ± 50 c/s and ± 500 c/s can be set up by the use of capacitors S and M.

Mc/s V.F.O. Calibration

7. (1) Set the R.F. GAIN control fully clockwise (maximum).
- (2) Set the XTAL - V.F.O. switch to V.F.O.
- (3) Set the TRANSMISSION SELECTOR to C.W.
- (4) Set the INPUT switch to SPACE.
- (5) Set the SIDEBAND switch to DOUBLE.
- (6) Set the METER switch to R.F. LEVEL.
- (7) Set the CALIBRATE switch to OFF.
- (8) Set the KC/S dial to 0.
- (9) Set the MC/S dial to the centre of the 2 Mc/s dial mark.
- (10) Adjust the core of L29 (see Fig. 12) to obtain maximum output on the meter, reducing the R.F. GAIN control as necessary.
- (11) Set the KC/S dial to 1000 kc/s and the MC/S dial to the centre of the 29 Mc/s dial mark.
- (12) Adjust capacitor C128 for maximum output on the meter.
- (13) Repeat operations (9) to (12) until the calibration is correct.
- (14) Rotate the MC/S dial from 29 Mc/s to 2 Mc/s and check that all Mc/s scale divisions are within their relevant dial marks as indicated by maximum readings on the meter.
- (15) Set the KC/S dial to 0, rotate the MC/S dial from 2 Mc/s to 29 Mc/s and check that all Mc/s scale divisions are within their relevant dial marks as indicated by maximum readings on the meter.

Kc/s V.F.O. Calibration

8. (1) Set the XTAL - V.F.O. switch to V.F.O.
- (2) Set the TRANSMISSION SELECTOR to C.W.
- (3) Set the INPUT switch to SPACE.
- (4) Set the SIDEBAND switch to DOUBLE.
- (5) Set the METER switch to CALIBRATE.
- (6) Set the CALIBRATE switch to 100 KC/S.
- (7) Connect the Headphones Item (j) to unit (PHONE jack socket).
- (8) Centralize the KC/S cursor.
- (9) Set the KC/S scale to 0.
- (10) A 'zero beat' should be obtained: If not adjust C46 (oven 1) until 'zero beat' is obtained with nearest 100 kc/s check frequency.
- (11) Set the KC/S scale to 1000 kc/s.
- (12) A 'zero beat' should be obtained: If not adjust core of L14 (oven 1) until 'zero beat' is obtained with nearest 100 kc/s check frequency.
- (13) Repeat operations (9) to (12) until optimum result is obtained.
- (14) Check for 'zero beat' at all 100 KC/S calibration marks (eleven) on KC/S scale are within ± 3 kc/s of the relevant KC/S scale position.
- (15) Set the CALIBRATE switch to 10 KC/S and check that nine calibration marks are audible between each 100 kc/s mark.
- (16) Set the METER switch to R.F. LEVEL and the CALIBRATE switch to OFF.

Pilot Carrier Check

9. (1) Remove the 75 Ω resistor and connect the Spectrum Analyser Item (h) input between PL2 and earth.
- (2) Set the TRANSMISSION SELECTOR to C.W. and the INPUT switch to SPACE.
- (3) Tune the Drive Unit to 3.5 Mc/s for a C.W. output of 0dB on the meter.
- (4) Set the Spectrum Analyser to display 3.5 Mc/s at 0dB.
- (5) Set TRANSMISSION SELECTOR to PILOT.
- (6) Check that adjustment of pre-set capacitor C145, marked 'C' on front panel, varies the carrier level between -6dB and -26dB.
- (7) Remove the Spectrum Analyser and reconnect the 75 Ω resistor between PL2 and earth.

Input Level Checks

10. (1) Connect the Oscilloscope, Item (g), across the 75-ohm resistor between PL2 and earth.
- (2) Set the TRANSMISSION SELECTOR to C.W. the SIDEBAND switch to DOUBLE, the INPUT switch to SPACE and the OUTPUT RANGE switch to 3 - 6.
- (3) Tune the Drive Unit to 3.5 Mc/s, for a C.W. output 0dB on meter using the R.F. GAIN control and the OUTPUT TUNING control.
- (4) Set the TRANSMISSION SELECTOR to PILOT.
- (5) Set capacitor 'C' for -6dB on the meter
- (6) Set the INPUT switch to OPERATE.
- (7) Connect the balanced output of the Audio Signal Generator, Item (a) to PL15 pins 9 and 10 and set the frequency 1500 c/s.
- (8) Set the signal generator output level to 0dBm (0.775 volts) and from the oscilloscope display check that 95% modulation can be obtained within the range of the A.F. GAIN control.

- (9) Repeat operation (8) with generator output level at -20dBm (.078 volts) and +10dBm (2.45 volts).
- (10) Set the INPUT selector switch to AUDIO.
- (11) Transfer the signal generator from pins 9 and 10 to pins 11 and 12 of PL15.
- (12) Repeat operation (8) and (9).
- (13) Disconnect the Oscilloscope and Audio Signal Generator.

F.S.K. and Keying Checks

11. (1) Remove the 75Ω resistor and connect the Spectrum Analyser Item (h) input between PL2 and earth.
- (2) Set the TRANSMISSION SELECTOR to C.W. and the INPUT switch to SPACE.
- (3) Tune the Drive Unit to 3 Mc/s, for a C.W. output of 0dB on the meter.
- (4) Set the Spectrum Analyser to display 3 Mc/s at 0dB.
- (5) Set the INPUT switch to MARK and check that the output decreases by more than 60dB on the Spectrum Analyser.
- (6) Set the INPUT switch to SPACE and check that the 0dB output is restored.
- (7) Remove the link between pins 3 and 4 on PL15 and check that the output displayed on the Spectrum Analyser decreases by more than 60dB. Reconnect the link to restore to 0dB output.
- (8) Set the INPUT switch to MARK, disconnect the Spectrum Analyser, reconnect the 75Ω resistor and connect the Frequency Meter Item (c) across this resistor.
- (9) Set the TRANSMISSION SELECTOR to F.S.K., the INPUT switch to SPACE and check that the output frequency is 3 Mc/s plus that set by preset capacitor 'S' i.e. between 100 c/s and 1000 c/s.
- (10) Set INPUT switch to MARK and check that output frequency is 3 Mc/s minus that set by preset capacitor 'M'.
- (11) Disconnect the Frequency Meter.

Output Level Check

12. (1) Connect the Valve Voltmeter Item (d) across the 75-ohm resistor between PL2 and earth.
- (2) Set the XTAL - V.F.O. switch to V.F.O.
- (3) Set the TRANSMISSION SELECTOR to C.W.
- (4) Set the INPUT switch to SPACE.
- (5) Set the SIDEBAND switch to DOUBLE.
- (6) Set the METER switch to R.F. LEVEL.
- (7) Set the CALIBRATE switch to OFF.
- (8) Tune the Drive Unit to 1.5 Mc/s, for a C.W. output of 0dB on meter, and then set the R.F. GAIN control fully clockwise.
- (9) The Valve Voltmeter reading should be not less than 3.87 volts.
- (10) Repeat operations (8) and (9) with the MC/S dial set to each megacycle between 2 and 29, and also the KC/S scale set to 0 to 1000.

Crystal Frequency Stability

13. NOTE: This procedure assumes that the Drive Unit has had a warming-up time of an hour since the channel crystals were inserted.
- (1) Connect the Frequency Meter Item (c) across the 75-ohm resistor between PL2 and earth.
- (2) Set the MC/S scale to 2 and the XTAL - V.F.O. switch to Channel 1.
- (3) Tune the Drive Unit for a C.W. output, of 0dB on the meter.
- (4) Check that the Frequency Meter displays the required 'kilo-cycles' content of the r.f. output. If necessary adjust the appropriate trimmer capacitor (see Section 1, Chapter 2, Table 1) to obtain the correct Frequency Meter indication and note this frequency.

- (5) Repeat operation (4) for each of the remaining channel positions on the XTAL - V.F.O. switch.
- (6) Set the MC/S scale to 25, repeat operation (3) and note the Frequency Meter indications for positions 1 to 6 of the XTAL - V.F.O. switch.
- (7) Retune the Drive Unit to 2 Mc/s and after a period of four hours, check that the frequency drift does not exceed ± 5 parts in 10^6 for positions 1 to 6 on the XTAL - V.F.O. switch.
- (8) Retune the Drive Unit to 25 Mc/s and check that the frequency drift does not exceed ± 2 parts in 10^6 for positions 1 to 6 on the XTAL - V.F.O. switch after four hours.

V.F.O. Frequency Stability

14. NOTE: This procedure assumes that the unit has been switched on for at least an hour.

- (1) Connect the Frequency Meter Item (c) across the 75-ohm resistor between PL2 and earth.
- (2) Set the FINE FREQUENCY dial to zero and XTAL - V.F.O. switch to V.F.O.
- (3) Set the TRANSMISSION SELECTOR to C.W.
- (4) Set the INPUT switch to SPACE.
- (5) Tune the Drive Unit to 3 Mc/s for a C.W. output of 0dB on meter.
- (6) Set the CALIBRATE switch to 100 KC/S.
- (7) Set the METER switch to CALIBRATE and plug headphones Item (j) into the PHONE socket.
- (8) Set the KC/S scale to the 100 kc/s mark and tune for 'zero beat' indication on meter and headphones.
- (9) Set the CALIBRATE switch to 1.6 Mc/s.
- (10) Adjust the FINE FREQUENCY control for 'zero beat' indication on meter and headphones.

- (11) Set the METER switch to R.F. LEVEL.
- (12) Set the CALIBRATE switch to OFF and the FREE-LOCK control to LOCK.
- (13) The reading on Frequency Meter should be 3.100 Mc/s; the error and drift on this reading after four hours should not exceed ± 200 c/s or 50 c/s in any one hour.

Harmonic Distortion Check

15. (1) Remove the 75Ω resistor and connect the Spectrum Analyser Item (h) input between PL2 and earth.
- (2) Set the TRANSMISSION SELECTOR to C.W. and the INPUT switch to SPACE.
- (3) Tune the Drive Unit to 7 Mc/s for a C.W. output of 0dB on the meter.
- (4) Set the Spectrum Analyser to display the frequency at 0dB level.
- (5) Tune the Drive Unit to 3.5 Mc/s for a C.W. output, of 0dB on the meter.
- (6) Increase the Spectrum Analyser gain by 30dB using the +30dB filter switch.
- (7) Measure the level of the 2nd harmonic (7 Mc/s), which must be more negative than -40dB.
- (8) Using operations (3) to (7) as a basis, repeat at frequencies 1.5 Mc/s, 2 Mc/s etc. to 15 Mc/s in 1 Mc/s steps if a full check is required. The 2nd Harmonic level must be more negative than -40dB relative to the fundamental level in all cases.

Two Tone Distortion

16. (1) The Spectrum Analyser Item (h) is connected as in paragraph 15.
- (2) Tune the Drive Unit to 3.5 Mc/s for a C.W. output of 0dB on the meter.

- (3) Adjust the Spectrum Analyser to display this frequency at 0dB level.
- (4) Connect the balanced output of the Two-Tone Oscillator, Item (f), between pins 9 and 10 of PL15 with outputs set to minimum.
- (5) Set the TRANSMISSION SELECTOR to SUPPRESSED, the INPUT switch to OPERATE, the SIDEBAND switch to UPPER and the A.F. GAIN control to maximum.
- (6) Set the Two-Tone Oscillator for two tone operation at frequencies of 1100 c/s and 1775 c/s and set the level of each tone for -6dB on the Drive Unit meter.
- (7) Adjust the Spectrum Analyser to display the two tones at 0dB level.
- (8) Increase the Spectrum Analyser gain by 30dB and check that the intermodulation products are more negative than -40dB.
- (9) Set the SIDEBAND switch to LOWER and repeat operations (7) and (8).

A.L.C. Check

17. (1) The Spectrum Analyser Item (h) is connected as in paragraph 15.
- (2) Set the TRANSMISSION SELECTOR to C.W. and the INPUT switch to SPACE.
- (3) Tune the Drive Unit to 3 Mc/s for a C.W. output of 0dB on the meter.
- (4) Set the Spectrum Analyser to display this frequency at a level of 0dB.
- (5) Connect -0.5 volts d. c. between pin 2 PL15, and earth with positive to earth.
- (6) Set the MANUAL/AUTO switch to AUTO.
- (7) Check the output level on the Spectrum Analyser is between -6dB and -8dB relative to the 0dB level.

- (8) Set the TRANSMISSION SELECTOR to PILOT and the MANUAL/AUTO switch to MANUAL.
- (9) Connect the Audio Signal Generator Item (a) output, set to 1,550 c/s, between pins 9 and 10 of PL15.
- (10) Set the output from the Signal Generator to 0dBm (0.775 volts).
- (11) Set the INPUT switch to OPERATE and the A.F. GAIN control to give 0dB on the Drive Unit meter.
- (12) Set the MANUAL/AUTO switch to AUTO.
- (13) Increase the bias volts applied to pin 2 of PL15 until the output indicated on the Drive Unit meter is -3dB and note this bias voltage. This voltage should be within the limits of -1.1 volts to -1.7 volts.
- (14) Set the MANUAL/AUTO switch to MANUAL and the TRANSMISSION SELECTOR to SUPPRESSED.
- (15) Adjust the A.F. GAIN control to give 0dB on the meter.
- (16) Reduce the bias volts applied to pin 2 of PL15 to -0.5 volts and set the MANUAL/AUTO switch to AUTO.
- (17) Check that the Spectrum Analyser output level is between -6dB and -8dB relative to the 0dB level.
- (18) Disconnect the bias voltage from pin 2 of PL15, the Spectrum Analyser from PL2 and reconnect the 75-ohm resistor to PL2.

1.4 Mc/s Output Check

18. (1) Connect the Valve Voltmeter Item (d) between PL20 (1.4 Mc/s OUTPUT socket) and earth.
- (2) Check that the output voltage is not less than 2.5 volts for the MA.79D or between 1 volt and 2 volts for the MA.79 G and H.
- (3) If the output voltage is low; a very slight re-adjustment of the cores for L53 should be made.
- (4) Disconnect the Valve Voltmeter.

1.4 Mc/s Input Check

19. (1) Set the TRANSMISSION SELECTOR to C.W. and the INPUT switch to SPACE.
- (2) Tune the Drive Unit to 3 Mc/s at maximum C.W. output, i.e. 0dB on the meter.
- (3) Set the TRANSMISSION SELECTOR to PILOT and the SIDE-BAND switch to EXT. The meter reading should fall to -6dB, if not adjust preset C to obtain -6dB.
- (4) Connect the Signal Generator Item (b), set the 1.4 Mc/s, between PL17 and earth.
- (5) Connect the Valve Millivoltmeter Item (e) across the Signal Generator output.
- (6) Increase the Signal Generator output until 0dB is obtained on the Drive Unit meter and check that the Valve Millivoltmeter reads between 10 and 15 mV.
- (7) Select SUPP. on the TRANSMISSION SELECTOR, increase the Signal Generator output to obtain 0dB on the Drive Unit meter and check that the Valve Millivoltmeter reads between 20 and 25 mV.
- (8) Remove the Signal Generator and the Valve Millivoltmeter.

NOTE: The signal levels given below in paragraphs 20 and 21 are typical levels to be expected from an accurately aligned Drive Unit.

R.F. Levels - Modulator Chassis

C.W. Conditions

20. (1) Disconnect PL8 from SK8 and terminate SK8 with a 1 kilohm resistor Item (m).
- (2) Set the R.F. GAIN control to the fully clockwise position.
- (3) Connect the Valve Millivoltmeter Item (e), set to the 300 mV range, across the terminating resistor. The voltmeter should indicate 160 mV.

- (4) Rotate the KC/S control through its complete range and check that the voltmeter reading does not vary by more than $\pm 3\text{dB}$.
- (5) Disconnect the Valve Millivoltmeter from the terminating resistor and set it to the 100 mV range.
- (6) Set the XTAL/V.F.O. switch to EXT.
- (7) Using the Valve Millivoltmeter, measure the r.f. level on grid 1 (pin 2) of V10. A level of 70 mV ± 10 mV should be indicated.
- (8) Using the Valve Millivoltmeter, measure the r.f. level on grid 1 (pin 1) of V12. A level of 30 mV $\pm 5\text{mV}$ should be indicated.
- (9) Remove V5 and measure the r.f. level on grid 3 (pin 9) of V8. The Valve Millivoltmeter should indicate 20 mV $\pm 5\text{mV}$.

NOTE: On latest equipments an 8.2 kilohm resistor is fitted across L13A. In these equipments the reading should be 90 mV ± 20 mV.

- (10) Remove V19 and measure the r.f. level on grid 3 (pin 9) of V25. The Valve Millivoltmeter should indicate 9mV $\pm 2\text{mV}$.

NOTE: On the latest equipments an 8.2 kilohm resistor is fitted across L25A. In these equipments the reading should be 50 mV ± 10 mV.

- (11) Set the TRANSMISSION selector to SUPP., the INPUT selector to AUDIO and the SIDEBAND selector to UPPER.
- (12) Connect the Audio Signal Generator Item (a) to PL15, pins 11 and 12; to 1500 c/s at 1mW.
- (13) With the Valve Millivoltmeter set to the 300 mV range, monitor the a.f. level on the grid (pin 7) of V6b and adjust the A.F. GAIN control until a reading of 150 mV is obtained.
- (14) Remove PL10 and monitor the a.f. signal applied to the centre-tap of L18b (Test Point). This should be 130 mV ± 10 mV.

- (15) Replace PL10 and using the Valve Voltmeter Item (d), set to the 3V range, monitor the r.f. level on grid 1 (pin 1) of V9. This should be 1V \pm 0.2V.
 - (16) Set the Valve Voltmeter to the 30V range and monitor the r.f. level at the anode (pin 5) of V9. This should be 30V \pm 200 mV.
 - (17) Set the Valve Voltmeter to the 3V range and monitor the r.f. level between either end of L18B and earth. This should be 1.3V \pm 0.3V.
 - (18) Using the Valve Millivoltmeter, set to the 30 mV range, monitor the r.f. level on grid 1 (pin 1) of V22. This should be between 6 and 20 mV. Note the level obtained.
 - (19) Vary the Audio Signal Generator output frequency through the range 300 - 3000 c/s maintaining the output level constant. Continuously observe the r.f. level on grid 1 (pin 1) of V22 during this variation of frequency. The total variation in this level should not be greater than 3dB.
 - (20) Repeat operations (18) and (19) with the SIDEBAND selector set to LOWER. Disconnect signal generator.
 - (21) Using the Valve Millivoltmeter, set to the 1V range, monitor the r.f. level across R50. With the TRANSMISSION selector set to C.W. this level should be 450 mV.
- NOTE: Early models of the equipment have a 560 ohm resistor for R50. In such models the level should be 300 mV.
- (22) Replace V5 and V19.
 - (23) Using the Valve Voltmeter, set to the 10V range, monitor the r.f. level on grid 1 (pin 1) of V25. A level between 2.5 and 4V should be indicated.
 - (24) Repeat the procedure detailed in (23) for V8 grid 1 (pin 1). The level should be in the same range.
 - (25) Set the XTAL/V.F.O. switch to V.F.O. and using the Valve Voltmeter, 10V range, monitor the r.f. level on grid 1 (pin 2) of V10. This level should remain within the range 2.5V - 3.5V at all settings of the KC/S control.

- (26) Set the R.F. GAIN control fully anti-clockwise. Disconnect the 1 kilohm terminating resistor from SK8 and re-connect PL8.
- (27) Set the appropriate controls for c.w. emission at 3.5 Mc/s. Adjust the R.F. GAIN control for 0dB indication on the meter.
- (28) Vary the MC/S control throughout its range. The meter indication shall not vary be more than ± 4 dB.
- (29) Reset the controls for 3.5 Mc/s, 0dB on the meter.
- (30) Remove V17 and V18. Using the Valve Millivoltmeter, 300 mV range and input padded to 12 pF, monitor the r.f. level across R87. This level shall be within the range 70 mV - 200 mV for all settings of the KC/S control.
- (31) Replace V18 and repeat the procedure detailed in (30), with the Valve Voltmeter set to the 10V range and padded to a total of 12 pF. The level should be between 2V and 10V throughout the MC/S range.
- (32) Replace V17 and set R.F. GAIN control fully clockwise. Using the Valve Millivoltmeter monitor the r.f. level on grid 1 (pin 2) of V26. This level shall be 200 mV \pm 100 mV at all settings of the MC/S control.
- (33) Remove V30 and connect a 100 ohm resistor Item (o) between the cathode (pin 3) of V30 and earth. Using the Valve Voltmeter, 3V range, monitor the r.f. level across the 100 ohm resistor at all settings of the MC/S control. This level shall be 1V \pm 0.6V.
- (34) Disconnect the 100 ohm resistor and replace V30.

R.F. Levels - Main Chassis

21. (1) Using the Valve Millivoltmeter, 3V range, monitor the r.f. level across C29. This level shall be 2.5V \pm 0.5V.
- (2) Using the Valve Millivoltmeter monitor the r.f. level on the TP1, adjacent to V11. This level shall be 220 mV \pm 50 mV.

(3) Monitor the r.f. levels in the calibration sub-chassis, using either the Valve Voltmeter or the Valve Millivoltmeter as appropriate, at the following positions:-

- (i) Across R151 4V \pm 1V.
- (ii) Across L36B 7V \pm 2V.
- (iii) Across R159 3V \pm 0.5V.
- (iv) Across R177 100 mV \pm 20 mV (10 kc/s and 100 kc/s calibration markers).
- (v) Across R177 90 mV \pm 10 mV (1.6 Mc/s calibration markers).
- (vi) Across R175 1V \pm 0.1V.
- (vii) Across R174 350 mV \pm 50 mV (1.6 Mc/s Calibration markers). (Fine Tune set to \pm 500 kc/s).

CHAPTER 4

FAULT LOCATION

AND

REPRESENTATIVE TEST DATA

Introduction

1. The purpose of Table 1 is to locate a fault to a particular area of the Drive Unit. If this is achieved, Table 2 - 5 provide the stage-by-stage test data required for locating the faulty stage.

IMPORTANT

It should be borne in mind by the user that the signal levels given in Tables 2 to 5 are not to be taken as factory specification figures. This data is representative only and hence suitable for the purposes of fault finding.

Test Equipment

2. (a) Signal Generator, 10 kc/s to 72 Mc/s, 50-ohm output, 1 μ V to 1V e.m.f. e.g. Marconi TF144H/4.
- (b) Valve Voltmeter, 1 kc/s to 30 Mc/s, 1mV to 300mV direct;
10 kc/s to 30 Mc/s, 100mV to 30V via X100 attenuator;
input capacitance 2pF with and 7pF without attenuator;
e.g. Phillips GM6014.
- (c) Valve Voltmeter, 20 c/s to 1500 Mc/s, 300mV to 300V a. c.
Input capacitance 1.5pF.
e.g. Marconi TF1041C.
- (d) Audio Signal Generator, 300 c/s to 10 kc/s, 600-ohm output;
e.g. Advance J2.

Static Voltages

3. The following table provides the necessary information for checking static voltages throughout the Unit.

TABLE 1

<u>Test Point</u>	<u>Voltage \pm 10%</u>	<u>Multimeter Range</u>
V1 Pin 5	185	250 volts d. c.
Pin 7	185	250 volts d. c.
Pin 2	85	100 volts d. c.
V2 Pin 5	18	25 volts d. c.
Pin 7	100	250 volts d. c.
Pin 2	-	
V3 Pin 5	230	250 volts d. c.
Pin 7	90	100 volts d. c.
S1 set (V4 Pin 5	125	250 volts d. c.
to EXT (Pin 6	50	100 volts d. c.
V5 Pin 5	20	25 volts d. c.
Pin 7	105	250 volts d. c.
V6 Pin 6	200	250 volts d. c.
Pin 8	50	100 volts d. c.
Pin 7	6	10 volts d. c.
S1 set (V7 Pin 5	190	250 volts d. c.
(Pin 7	125	250 volts d. c.
VFO (Pin 1	-0.4	2.5 volts d. c.
V8 Pin 5	165	250 volts d. c.
Pin 6	80	100 volts d. c.
Pin 2	3	10 volts d. c.
V9 Pin 5	165	250 volts d. c.
Pin 7	105	250 volts d. c.

<u>Test Point</u>	<u>Voltage \pm 10%</u>	<u>Multimeter Range</u>
V10 Pin 7	170	250 volts d. c.
Pin 9	130	250 volts d. c.
Pins 1 & 3	1.0	2.5 volts d. c.
V11 Pin 5	240	250 volts d. c.
Pin 7	190	250 volts d. c.
Pin 2	2.7	10 volts d. c.
V12 Pin 5	200	250 volts d. c.
Pin 6	130	250 volts d. c.
V13 Pin 1	0.05	2.5 volts d. c.
Pin 2	0.05	2.5 volts d. c.
V14 Pin 5	225	250 volts d. c.
Pin 7	240	250 volts d. c.
Pin 2	2.2	2.5 volts d. c.
V15 Pin 5	250	500 volts d. c.
Pin 7	190	250 volts d. c.
Pin 2	1.5	2.5 volts d. c.
S3 set (V16 Pins 5 & 7 to RE- VERSALS(17	25 volts d. c.
Pin 1	3.7 a. c.	10 volts a. c.
V17 Pin 7	230	250 volts d. c.
Pin 9	185	250 volts d. c.
Pins 1 & 3	1.0	2.5 volts d. c.
V18 Pin 5	250	500 volts d. c.
Pin 7	230	250 volts d. c.
Pin 2	2.0	2.5 volts d. c.
V19 Pin 5	20	25 volts d. c.
Pin 7	105	250 volts d. c.
V20 Pin 7	180	250 volts d. c.
Pin 9	140	250 volts d. c.
Pins 1 & 3	1.2	2.5 volts d. c.

NOTE:1: In all tests, input levels quoted for the TF144H/4 are indicated e.m.f. The generator lead must be terminated with a 47-ohm resistor.

NOTE:2: The valve voltmeter must be padded to the required capacitance where stated. E.g. When padding to the 12pF, connect a 5pF capacitor across the GM6014.

TABLE 1

General Fault Finding

Ref.	TEST	FUNCTION	CAUSE OF FAILURE
1	Panel illumination	Indicates availability of a.c. supply	(i) No a.c. supply applied (ii) Power switch in OFF position. (iii) Fuse(s) open circuit.
2.	100 kc/s calibration tone	Indicates that: (i) The 1 Mc/s oscillator is functioning. (ii) The 100 kc/s divider is functioning. (iii) The kc/s v.f.o. is providing an output	(i) The divider stage not functioning. (ii) 1 Mc/s Oscillator not functioning. (iii) No output available from kc/s v.f.o.
3.	10 kc/s calibration tone	Indicates that: (i) As (i) in 2. above (ii) As (ii) in 2. above. (iii) As (iii) in 2. above. (iv) 10 kc/s divider is functioning.	(i) The divider stage is not functioning. (ii) As (ii) in 2. above. (iii) As (iii) in 2. above.

Ref.	TEST	FUNCTION	CAUSE OF FAILURE
4.	1.6 Mc/s Calibration tone	<p>With no a. f. input indicates that:</p> <p>(i) The 1.4 Mc/s signal is available.</p> <p>(ii) The i. f. stages up to the 1.6 Mc/s are functioning.</p> <p>(iii) The 100 kc/s divider is functioning.</p> <p>With an a. f. input the i. f. stages can be checked for distortion.</p>	<p>(i) The 100 kc/s divider faulty (see 2. above).</p> <p>(ii) V31 not functioning</p> <p>(iii). Fault in i. f. stages.</p> <p>Distortion may occur in any i. f. stage. Failure to produce any a. f. output indicates that balanced modulator has failed.</p>
5.	R. F. Level reading on meter.	Indicates that the drive unit is functioning correctly.	<p>After checks 1 - 4 have been made successfully the fault will be located in either:</p> <p>(i) R. F. level control - set low.</p> <p>(ii) Switches - incorrectly set</p> <p>(iii) Failure in the electronic bandswitching stages.</p> <p>(iv) Failure in output stage.</p>

Modulator Chassis

4. Before carrying out the tests of Table 2 only, connect audio modulation as indicated below.
- (1) Connect the output from the Advance J2 signal generator to pins 9 and 10 of PL15 on the rear.
 - (2) Set up the audio generator for a frequency of 1 kc/s; adjust the input level at pins 9 and 10 to be approximately 1mW into 600-ohms balanced.
 - (3) Set the INPUT SELECTOR switch to OPERATE.
 - (4) Set the R. F. and A. F. GAIN controls to maximum clockwise position.

- (5) Check with GM6014 valve voltmeter that approximately 150mV exists at pin 7 of V6B.
- (6) Proceed with the checks given in Table 2 below, referring to figure 10 as an aid to locating the test points.
- (7) Connect pin 5 to 6 and pin 3 to 4 of PL15 on the rear.

TABLE 2

Modulator Checks

TEST	TEST POINT	FREQ.	OUTPUT LEVEL	TEST EQUIP.	CONDITIONS
(a)	Pin 1, V9(G1)	1.4 Mc/s	1V	TF1041C	-
(b)	Pin 5, V9(A)	1.4 Mc/s	40V	TF1041C	-
(c)	Junction C67, R50	1.4 Mc/s	500 mV	TF1041C	-
(d)	L18B (each side)	1.4 Mc/s	2V	TF1041C	INPUT SELECTOR to AUDIO
(e)	(wiper) RV3	1.4 Mc/s	100 mV	GM6014	No change
(f)	L18B (centre tap)	1 kc/s	130 mV	GM6014	PL10 removed, TRANSMISSION SELECTOR to SUPP., INPUT SELECTOR to OPERATE.
(g)	Pin 1, V22(G1)	1.4 Mc/s	5 mV	GM6014	PL10 reconnected.
(h)	Pin 7, V25(G3)	1.4 Mc/s	30 mV	GM6014	Either sideband; oven 3 removed.
(j)	Pin 7, V25(G3)	1.4 Mc/s	45 mV	GM6014	Either sideband; oven 3 removed. TRANSMISSION SELECTOR to CW.
(k)	Pin 1, V25(G1)	10.2 Mc/s	2 to 10V	GM6014	Oven 3 reinserted.
(m)	Pin 1, V8(G1)	10 Mc/s	2 to 4V	GM6014	No change.
(n)	Pin 7, V8(G3)	11.6 Mc/s	60 mV	GM6014	TRANSMISSION SELECTOR to CW.

(p)	PL13	1.6 Mc/s	100 mV	GM6014	No change.
(q)	Pin 1, V12(G1)	1.6 Mc/s	25 mV	GM6014	No change.
(r)	Pin 5, V16(A)	50 c/s	10V	TF1041C	INPUT SELEC- TOR to REV- ERSALS.
(s)	Junction C70, R60	1.6 Mc/s	70 mV	GM6014	INPUT SELEC- TOR to AUDIO, XTAL. V.F.O. to EXT.
(t)	Junction C70, R60	3.6 to 4.6 Mc/s	2 to 4V	GM6014	XTAL. V.F.O. to V.F.O.
(u)	SKT8 into 1k to chassis	2 to 3 Mc/s	170 to 230 mV	GM6014	No change.

Calibration Chassis

5. Ensure that no external connections are made to the EXT. XTAL. plug (PL14) on the rear of the Drive Unit. Refer to figure 9 as an aid to locating test points.

TABLE 3

Calibrator Checks

TEST	TEST POINT	FREQ.	OUTPUT LEVEL	TEST EQUIP.	CONDITIONS
(a)	Either end R120	100 kc/s	8V	GM6014	CALIBRATE switch to OFF
(b)	Pin 1, V29(G1)	100 kc/s	3V	GM6014	No change.
(c)	Pin 5, V21(A)	10 kc/s	45V	TF1041C	CALIBRATE switch to 10 kc/s
(d)	Pin 5, V29(A)	(Harmonics of 100 kc/s and 10 kc/s, and 3.6 to 4.6 Mc/s	25V	TF1041C	No change.
(e)	Pin 5, V29(A)	(Harmonics of 100 kc/s, 3.6 to 4.6 Mc/s.	8V	TF1041C	CALIBRATE switch to 100 KC/S.

(f)	Pin 1, V33(G1)	1.6 Mc/s	20 mV	GM6014	CALIBRATE switch to 1.6 Mc/s and XTAL V.F.O. to XTAL. EXT.
(g)	Pin 1, V33(G1)	(Harmonics of 100 kc/s, (and 3.6 to 4.6 Mc/s	60 mV	GM6014	No change.
(h)	Pin 1, V33(G1)	(Harmonics of 10 kc/s (and 100 kc/s, (and 3.6 to 4.6 Mc/s	35 mV	GM6014	CALIBRATE switch to 10 KC/S and XTAL. V.F.O. to XTAL. EXT.
(j)	Pin 7, V33(G3)	1.6 Mc/s	500 mV	GM6014	CALIBRATE switch to 1.6 MC/S.
(k)	Pin 7, V33(G3)	3.6 to 4.6 Mc/s	1V	GM6014	CALIBRATE switch to 100 kc/s and XTAL. V.F.O. to V.F.O.
(m)	Pin 1, V32(G1)	Varying audio beat-note	200 mV (min)	TF1041C	CALIBRATE switch to 1.6 MC/S and TRANSMISSION SELECTOR to C.W. Adjust FINE FREQ. control.
(n)	Pin 1, V32(G1)	Varying audio beat-note	50 mV (min.)	TF1041C	CALIBRATE switch to 10 KC/S. Adjust KC/S control to multiples of 10 kc/s.
(p)	Pin 1, V32(G1)	Varying audio beat-note	200 mV (min.)	TF1041C	CALIBRATE switch to 100 KC/S. Adjust KC/S control to multiples of 100 kc/s.

(q)	Pin 5, V32(A)	Varying audio beat-note	10V (min)	TF1041C	CALIBRATE switch to 1.6 MC/S. Adjust FINE FREQ. control.
(r)	Pin 5, V32(A)	Varying audio beat-note	3V (min.)	TF1041C	CALIBRATE switch to 100 KC/S. Adjust KC/S control to multiples of 100 kc/s.
(s)	Pin 5, V32(A)	Varying audio beat-note	3V (min.)	TF1041C	CALIBRATE switch to 10 KC/S. Adjust KC/S control to multiples of 10 kc/s.
(t)	Pin 1, V31(G1)	100 kc/s	2.5 V	TF1041C	CALIBRATE switch to OFF.
(u)	L54B	1.6 Mc/s	500 mV	TF1041C	CALIBRATE switch to 1.6 MC/S.

MAIN CHASSIS

6. Tests on the main chassis are broken down into a number of areas viz. harmonic generating stages, 37.5 Mc/s stages, 40 Mc/s filter and amplifier, Mc/s V.F.O. and overall check.

harmonic Generating Stages (V1, V3 and V11)

7. Proceed with the checks listed in Table 4. Refer to figure 8 as an aid to locating test points.

TABLE 4

Harmonic Generator Checks

TEST	TEST POINT	FREQ.	OUTPUT LEVEL	TEST EQUIP.	CONDITIONS
(a)	Pin 5, V1(A)	1 Mc/s	125 V	TF1041C	-
(b)	Pin 1, V3(G1)	1 Mc/s	30V	TF1041C	-

(c)	Pin 5, V3(A)	Harmonics of 1 Mc/s	3.5V	TF1041C	-
(d)	SKT6	1 Mc/s	2.5V	TF1041C	-
(e)	Pin 6, V11(G3)	Harmonics of 1 Mc/s	350 mV	TF1041C	CALIBRATE switch to 100 KC/S.
(f)	Pin 1, V11(G1)	41.5 to 69.5 Mc/s	1.5 to 3V	TF1041C	-

37.5 Mc/s Stages (V11, V15, V18 and V14)

8. Refer to figure 8 as an aid to locating test points.
- (1) Connect the TF1041C valve voltmeter to TP2 (adjacent to V17); pad the voltmeter to a total of 12 pF.
 - (2) Remove V17.
 - (3) Rotate the MEGACYCLES control from position 1 to 29 and check that the level of the 37.5 Mc/s signal at TP2 is in the range of 2 to 10 volts.
 - (4) Set the CALIBRATE switch to 100 KC/S.
 - (5) Referring to Table 5, connect the TF144H/4 signal generator (terminated with 47 Ω), in turn, to each of the test points listed. Tune the generator to 37.5 Mc/s and set the output level (indicated generator e. m. f.) as indicated in Table 5.
 - (6) Check that the valve voltmeter indicates approximately 1 volt for tests (a) to (e) of Table 5.

TABLE 5

37.5 Mc/s Amplifier Checks

37.5 Mc/s Input Point	E. M. F. For 1V Out at TP2
(a) Pin 1, V14(G1)	110 mV
(b) Pin 1, V18(G1)	52 mV
(c) Pin 1, V15	7.5 mV
(d) Pin 6, V11(G3)	6.4 mV
(e) Pin 1, V11(G1)	1.5 mV

40 Mc/s Filter and Amplifier (V17)

9. (1) Connect the TF144H/4 signal generator (terminated with 47Ω) to TP2 (adjacent to V17).
- (2) Tune generator to 40 Mc/s.
- (3) Set CALIBRATE switch to 100 KC/S.
- (4) Remove V20 (fig. 7).
- (5) Connect the TF1041C valve voltmeter, padded to a total of 12pF, to TP3 (between V20 and V23, Mc/s module).
- (6) Set the output level of the generator to 65 mV and check that the voltmeter indicates approximately 100 mV at the peak of the filter passband.
- (7) Refit V20 and remove test equipment.

Mc/s V.F.O. Stages

10. Refer to figure 12 as an aid to locating the test points. Access to the test points quoted in Table 6 is from the top of the chassis and via the valvholder with the valve removed. Connection to the valvholder can be eased by making up two adaptors using a B9A and a B7G plug. When connecting the TF144H/4 generator in test (c) of Table 6, remove V26, insert a suitable length of wire into pin 3 and replace the valve; terminate the generator output with 47 ohms.

TABLE 6

Mc/s V.F.O. Checks

TEST	TEST POINT	FREQ.	OUTPUT LEVEL	TEST EQUIP.	CONDITIONS
(a)	Pin 2, V26(G1)	1.5 to 30 Mc/s	50 to 250 mV	(TF1041C (TF144H/4	V26 removed. XTAL. V.F.O. to EXT. Valve voltmeter padded to a total of 12 pF 200 mV e. m. f. input to grid 1 of V20. After test, replace V26.

(b)	Pin 1, V20(K)	41.5 to 69.5 Mc/s	0.8 to 1.3V	TF1041C	V20 removed. 68 ohm resistor connected between pin 1 of V20 and chassis. Mc/s control rotated from 1 to 29. After test re- place V20.
(c)	Pin 3, V30(K)	1.5 to 30 Mc/s	0.3 to 0.6V	(TF1041C (TF144H/4	V30 removed. CALIBRATE switch to 100 kc/s. 100mV e. m. f. input (TF144H) to pin 2 of V26. 100 ohm re- sistor connected between pin 3 of V30 and chassis. Re- move 100 ohm resistor and valve voltmeter after test. Re- place V30. (refer to para. 10 below).

11. With the signal generator still connected to pin 2 of V26, and the controls still set as for test (c) of Table 6, proceed as follows:
- (1) Set the METER switch to R. F. LEVEL.
 - (2) Terminate the R. F. OUT plug (PL2) with 75 ohms.
 - (3) Tune the generator over the range of 1.5 to 30 Mc/s and continuously adjust the generator output e. m. f. for a constant indication of 0 dB on the Drive Unit meter.
 - (4) Check that the generator output level remains in the range of 50 to 200 mV under the conditions of operation (3) above.
 - (5) Remove all test equipment.

OVERALL CHECK

12. (1) Disconnect PL8.
- (2) Connect the TF144H/4 generator terminated in 47 ohms, to PL8
- (3) Set the XTAL V.F.O. switch to EXT.
- (4) Set the CALIBRATE switch to OFF.
- (5) Tune the generator over the range of 2 to 3 Mc/s and check that for a Drive Unit meter indication of 0 dB, the generator e. m. f. remains in the range of 80 to 250 mV.

CHAPTER 5

PARTS LIST

Cct. Ref.	Value	Description	Rat.	Tol. ± %	Racal Part No.	Manufacturer.
	<u>Ohms</u>	<u>RESISTORS</u>				
R1	4.7k	Carbon	$\frac{1}{2}W$	10	902370	Erie 8
R2	100k	Carbon	$\frac{1}{4}W$	10	902459	Erie 16
R3	33k	Carbon	$\frac{1}{4}W$	10	902453	Erie 16
R4	100k	Carbon	$\frac{1}{4}W$	10	902459	Erie 16
R5	560	Carbon	$\frac{1}{4}W$	10	902432	Erie 16
R6	22k	Carbon	$\frac{1}{4}W$	10	902451	Erie 16
R8	56k	High Stability	$\frac{1}{2}W$	5	902456	Painton 73
R9	22k	Carbon	$\frac{1}{4}W$	10	902451	Erie 16
R11	330	Carbon	$\frac{1}{4}W$	10	902429	Erie 16
R12	470k	Carbon	$\frac{1}{4}W$	10	902467	Erie 16
R13	47k	Carbon	$\frac{1}{4}W$	10	902455	Erie 16
R14	1k	Metal Oxide		5	906031	Electrosil TR5
R15	1k	Metal Oxide		5	906031	Electrosil TR5
R16A	33k	Carbon	$\frac{1}{4}W$	10	902453	Erie 16
R16B	33k	Carbon	$\frac{1}{4}W$	10	902453	Erie 16
R17	10k	Carbon	$\frac{1}{4}W$	10	902447	Erie 16
R18	10k	Carbon	$\frac{1}{4}W$	10	902447	Erie 16
R19	27k	Carbon	$\frac{1}{2}W$	10	902379	Erie 8
R21	100k	Carbon	$\frac{1}{4}W$	10	902459	Erie 16
R22	22k	Carbon	$\frac{1}{4}W$	10	902451	Erie 16
R23	4.7k	Carbon	$\frac{1}{4}W$	10	902443	Erie 16
R24	1k	Carbon	$\frac{1}{2}W$	10	902362	Erie 8
R25	33k	Metal Oxide		5	911825	Electrosil TR6
R26A	68k	Carbon	$\frac{1}{2}W$	10	902384	Erie 8
R27	33k	Carbon	$\frac{1}{2}W$	10	902308	Erie 8
R28	33k	Carbon	$\frac{1}{4}W$	10	902453	Erie 16
R29	47k	Carbon	$\frac{1}{4}W$	10	902455	Erie 16
R30	8.2k	Carbon	$\frac{1}{4}W$	10	902446	Erie 16
R31	22k	Carbon	$\frac{1}{4}W$	10	902451	Erie 16
R32	220	Carbon	$\frac{1}{4}W$	10	902427	Erie 16
R33	220k	Carbon	$\frac{1}{4}W$	10	902463	Erie 16
R34	4.7k	Carbon	$\frac{1}{2}W$	10	902370	Erie 8

Cct. Ref.	Value	Description	Rat.	Tol. ± %	Racal Part No.	Manufacturer.
	<u>Ohms</u>	<u>Resistors - Cont'd.</u>				
R35	47k	Carbon	$\frac{1}{4}W$	10	902455	Erie 16
R36	1M	Carbon	$\frac{1}{4}W$	10	902471	Erie 16
R37	10k	Carbon	$\frac{1}{4}W$	10	902447	Erie 16
R38	220	Carbon	$\frac{1}{4}W$	10	902427	Erie 16
R40	33	Carbon	$\frac{1}{2}W$	10	902344	Erie 8
R42	1M	Carbon	$\frac{1}{4}W$	10	902471	Erie 16
R44	1k	Carbon	$\frac{1}{4}W$	10	902435	Erie 16
R45	470	Carbon	$\frac{1}{4}W$	10	902431	Erie 16
R46	470k	Carbon	$\frac{1}{4}W$	10	902467	Erie 16
R47	10k	Carbon	$\frac{1}{4}W$	10	902447	Erie 16
R48	10	Carbon	$\frac{1}{4}W$	10	902411	Erie 16
R49	2.2k	Carbon	$\frac{1}{4}W$	10	902439	Erie 16
R50	680	Carbon	$\frac{1}{4}W$	10	902433	Erie 16
R51	220	Carbon	$\frac{1}{4}W$	10	902427	Erie 16
R52	10k	High Stability	$\frac{1}{4}W$	5	902985	Painton 72
R53A	33k	Carbon	$\frac{1}{2}W$	10	902380	Erie 8
R53B	33k	Carbon	$\frac{1}{2}W$	10	902380	Erie 8
R54A	3.9k	Carbon	$\frac{1}{4}W$	10	902442	Erie 16
R54B	1.8k	Carbon	$\frac{1}{4}W$	10	902438	Erie 16
R55	470k	Carbon	$\frac{1}{4}W$	10	902467	Erie 16
R56	47k	Carbon	$\frac{1}{4}W$	10	902455	Erie 16
R56A	33k	Carbon	$\frac{1}{2}W$	10	902380	Erie 8
R57	1k	Carbon	$\frac{1}{4}W$	10	902435	Erie 16
R58	22k	Carbon	$\frac{1}{4}W$	10	902451	Erie 16
R59	1k	High Stability	$\frac{1}{2}W$	5	903098	Painton 73
R60	10	Carbon	$\frac{1}{4}W$	10	902411	Erie 16
R61	470k	Carbon	$\frac{1}{4}W$	10	902467	Erie 16
R62	68	Carbon	$\frac{1}{4}W$	10	902421	Erie 16
R63	1k	Carbon	$\frac{1}{4}W$	10	902435	Erie 16
R64	1k	Carbon	$\frac{1}{4}W$	10	902435	Erie 16
R65	10	Carbon	$\frac{1}{4}W$	10	902411	Erie 16
R66	10	Carbon	$\frac{1}{4}W$	10	902411	Erie 16
R67	10k	Carbon	$\frac{1}{4}W$	10	902447	Erie 16
R68	2.2k	Carbon	$\frac{1}{4}W$	10	902439	Erie 16
R69	220	Carbon	$\frac{1}{4}W$	10	902427	Erie 16
R70	8.2k	Carbon	$\frac{1}{4}W$	10	902446	Erie 16

Cct. Ref.	Value	Description	Rat.	Tol. ± %	Racal Part No.	Manufacturer.
	<u>Ohms</u>	<u>Resistors - Cont'd.</u>				
R71	2.2k	Carbon	$\frac{1}{4}W$	10	902439	Erie 16
R72	22k	Carbon	$\frac{1}{4}W$	10	902451	Erie 16
R73	220k	Carbon	$\frac{1}{4}W$	10	902463	Erie 16
R74	15k	High Stability	$\frac{1}{4}W$	5	902989	Painton 72
R75	2.7k	Carbon	$\frac{1}{4}W$	10	902440	Erie 16
R76	1k	Carbon	$\frac{1}{4}W$	10	902435	Erie 16
R77	8.2k	Carbon	$\frac{1}{4}W$	10	902373	Erie 8
R78	100	High Stability	$\frac{1}{4}W$	5	902702	Painton 72
R81	100	High Stability	$\frac{1}{4}W$	5	902702	Painton 72
R82	10k	Carbon	$\frac{1}{4}W$	10	902447	Erie 16
R83	15k	Carbon	$\frac{1}{4}W$	10	902449	Erie 16
R84	33	Carbon	$\frac{1}{4}W$	10	902417	Erie 16
R85	10	Carbon	$\frac{1}{4}W$	10	902411	Erie 16
R86	150	Carbon	$\frac{1}{4}W$	10	902425	Erie 16
R87	470k	Carbon	$\frac{1}{4}W$	10	902467	Erie 16
R88	56	Carbon	$\frac{1}{4}W$	10	902420	Erie 16
R89	470	Carbon	$\frac{1}{4}W$	10	902431	Erie 16
R90	1k	High Stability	$\frac{1}{4}W$	5	902961	Painton 72
R91	10k	Carbon	$\frac{1}{4}W$	10	902447	Erie 16
R93	47k	Carbon	$\frac{1}{4}W$	10	902455	Erie 16
R94	10	Carbon	$\frac{1}{4}W$	10	902411	Erie 16
R95	150	Carbon	$\frac{1}{4}W$	10	902425	Erie 16
R96	33k	Carbon	$\frac{1}{4}W$	10	902453	Erie 16
R97	33k	Metal Oxide	$\frac{1}{2}W$	5	911825	Electrosil TR6
R98	220k	Carbon	$\frac{1}{4}W$	10	902463	Erie 16
R99	220	Carbon	$\frac{1}{4}W$	10	902427	Erie 16
R100	47k	Carbon	$\frac{1}{4}W$	10	902455	Erie 16
R101	100k	Carbon	$\frac{1}{4}W$	10	902459	Erie 16
R102	470k	Carbon	$\frac{1}{4}W$	10	902467	Erie 16
R103	47k	Carbon	$\frac{1}{4}W$	10	902455	Erie 16
R104	2.5k	Wirewound	3W	5	906101	Welwyn AW3115
R105	680	Carbon	$\frac{1}{4}W$	10	902433	Erie 16
R106	15k	Carbon	$\frac{1}{4}W$	10	902449	Erie 16

Cct. Ref.	Value	Description	Rat.	Tol. ± %	Racal Part No.	Manufacturer.
	Ohms	<u>Resistors - Cont'd.</u>				
R107	10	Carbon	$\frac{1}{4}W$	10	902411	Erie 16
R108	100k	Carbon	$\frac{1}{4}W$	10	902459	Erie 16
R109	68	Carbon	$\frac{1}{4}W$	10	902421	Erie 16
R110	1k	Carbon	$\frac{1}{4}W$	10	902435	Erie 16
R110A	1k	Carbon	$\frac{1}{4}W$	10	902435	Erie 16
R111	1k	Carbon	$\frac{1}{4}W$	10	902435	Erie 16
R112	470	Carbon	$\frac{1}{4}W$	10	902431	Erie 16
R113	1k	Carbon	$\frac{1}{4}W$	10	902435	Erie 16
R115	47k	Carbon	$\frac{1}{4}W$	10	902455	Erie 16
R116	10	Carbon	$\frac{1}{4}W$	10	902411	Erie 16
R117	2.2k	Carbon	$\frac{1}{4}W$	10	902439	Erie 16
R118	22k	Carbon	$\frac{1}{4}W$	10	902451	Erie 16
R119	22k	Carbon	$\frac{1}{2}W$	10	902378	Erie 8
R120	33k	Carbon	$\frac{1}{4}W$	10	902453	Erie 16
R121	68k	Carbon	$\frac{1}{4}W$	10	902457	Erie 16
R122	4.7k	Carbon	$\frac{1}{4}W$	10	902443	Erie 16
R123	82	Carbon	$\frac{1}{4}W$	10	902422	Erie 16
R124	180	Carbon	$\frac{1}{4}W$	10	902426	Erie 16
R125	22k	Carbon	$\frac{1}{4}W$	10	902451	Erie 16
R126	1M	Carbon	$\frac{1}{4}W$	10	902471	Erie 16
R128	22k	Carbon	$\frac{1}{4}W$	10	902451	Erie 16
R129	68k	Carbon	$\frac{1}{4}W$	10	902457	Erie 16
R129A	68k	Carbon	$\frac{1}{4}W$	10	902457	Erie 16
R131	33k	Carbon	$\frac{1}{2}W$	10	902380	Erie 8
R132	5.6	High Stability	$\frac{1}{2}W$	5	903116	Painton 73
R133	680	Carbon	$\frac{1}{4}W$	10	902433	Erie 16
R134	220k	Carbon	$\frac{1}{4}W$	10	902463	Erie 16
R135	220	Carbon	$\frac{1}{4}W$	10	902427	Erie 16
R136	22k	Carbon	$\frac{1}{4}W$	10	902451	Erie 16
R137	8.2k	Carbon	$\frac{1}{2}W$	10	902373	Erie 8
R138	8.2k	Carbon	$\frac{1}{2}W$	10	902373	Erie 8
R139	22k	Carbon	$\frac{1}{2}W$	10	902378	Erie 8
R141	68	Carbon	$\frac{1}{4}W$	10	902421	Erie 16
R143	2.2k	Carbon	$\frac{1}{4}W$	10	902439	Erie 8
R144	2.2k	Carbon	$\frac{1}{2}W$	10	902366	Erie 8
R145	22k	Carbon	$\frac{1}{2}W$	10	902378	Erie 8

Cct. Ref.	Value	Description	Rat.	Tol. ± %	Racal Part No.	Manufacturer.
	<u>Ohms</u>	<u>Resistors - Cont'd.</u>				
R146	68k	Carbon	$\frac{1}{2}W$	10	902384	Erie 8
R147	4.7k	Carbon	$\frac{1}{4}W$	10	902443	Erie 16
R148	220	Carbon	$\frac{1}{4}W$	10	902427	Erie 16
R149	22k	Carbon	$\frac{1}{4}W$	10	902451	Erie 16
R151	1M	Carbon	$\frac{1}{4}W$	10	902471	Erie 16
R152	1M	Carbon	$\frac{1}{4}W$	10	902471	Erie 16
R153	1k	Carbon	$\frac{1}{4}W$	10	902435	Erie 16
R154	10k	Carbon	$\frac{1}{2}W$	10	902374	Erie 8
R155	10k	Carbon	$\frac{1}{4}W$	10	902447	Erie 16
R156	10k	Carbon	$\frac{1}{4}W$	10	902447	Erie 16
R157	100k	Carbon	$\frac{1}{4}W$	10	902459	Erie 16
R158	47k	Carbon	$\frac{1}{2}W$	10	902382	Erie 8
R159	68k	Carbon	$\frac{1}{4}W$	10	902457	Erie 16
R161	1k	Wirewound	4.5W	5	903856	Painton 301A
R163	120	Carbon	$\frac{1}{2}W$	10	902351	Erie 8
R164	47	Carbon	$\frac{1}{4}W$	10	902419	Erie 16
R165	100	Carbon	$\frac{1}{4}W$	10	902423	Erie 16
R166	2.2k	Carbon	$\frac{1}{4}W$	10	902439	Erie 16
R167	150k	Carbon	$\frac{1}{2}W$	10	902388	Erie 8
R168	22k	Carbon	$\frac{1}{4}W$	10	902451	Erie 16
R169	27k	Carbon	$\frac{1}{2}W$	10	902379	Erie 8
R171	100k	Carbon	$\frac{1}{2}W$	10	902386	Erie 8
R172	100k	Carbon	$\frac{1}{2}W$	10	902386	Erie 8
R174	1M	Carbon	$\frac{1}{4}W$	10	902471	Erie 16
R175	220k	Carbon	$\frac{1}{4}W$	10	902463	Erie 16
R177	68k	Carbon	$\frac{1}{4}W$	10	902457	Erie 16
R178	22	Wirewound	4.5W	5	903816	Painton 301A
R179	68k	High Stability	$\frac{1}{4}W$	5	902770	Painton 72
R180	22k	Carbon	$\frac{1}{2}W$	10	902378	Erie 8
R181	8.2k	High Stability	$\frac{1}{4}W$	5	902748	Painton 72
R182	470	Wirewound	4.5W	5	903848	Painton 301A
R183	1k	Carbon	$\frac{1}{2}W$	10	902362	Erie 8
R184	100	Carbon	$\frac{1}{2}W$	10	902350	Erie 8
R185	68	Carbon	$\frac{1}{4}W$	10	902421	Erie 16
R186	2.2k	High Stability	$\frac{1}{2}W$	5	902969	Painton 72

Cct. Ref.	Value	Description	Rat. ± %	Tol.	Racal Part No.	Manufacturer.
	<u>Ohms</u>	<u>Resistors - Cont'd.</u>				
R187	680	Carbon	$\frac{1}{4}W$	10	902433	Erie 16
R188	330	Carbon	$\frac{1}{4}W$	10	902429	Erie 16
R189	180	Carbon	$\frac{1}{4}W$	10	902426	Erie 16
R190	1k	Carbon	$\frac{1}{4}W$	10	902435	Erie 16
R191	56k	Carbon	$\frac{1}{4}W$	10	902456	Erie 16
R192	470k	Carbon	$\frac{1}{4}W$	10	902467	Erie 16
R193	2.2k	Carbon	$\frac{1}{4}W$	10	902439	Erie 16
R194	680k	Carbon	$\frac{1}{4}W$	10	902469	Erie 16
R195	150k	Carbon	$\frac{1}{4}W$	10	902461	Erie 16
R196	150	Wirewound	6W	5	903941	Welwyn V3
R197	1k	Carbon	$\frac{1}{4}W$	10	902435	Erie 16
R198	470	Carbon	$\frac{1}{4}W$	10	902431	Erie 16
1R1	100k	Carbon	$\frac{1}{4}W$	10	902459	Erie 16
1R2	220k	Carbon	$\frac{1}{4}W$	10	902463	Erie 16
2R1	100k	Carbon	$\frac{1}{4}W$	10	902459	Erie 16
2R2	220k	Carbon	$\frac{1}{4}W$	10	902463	Erie 16
RV1	1k	Wirewound			906118	Colvern CLR3211/22
RV2	25k	Wirewound				Racal ASW16371
RV3	100	Wirewound				Racal ASW14520/1

	<u>μF</u>	<u>CAPACITORS</u>				
C1	3-30p	Variable			900134	Mullard E7876
C2	3-30p	Variable			900134	Mullard E7876
C3	3-30p	Variable			900134	Mullard E7876
C4	3-30p	Variable			900134	Mullard E7876
C5	3-30p	Variable			900134	Mullard E7876
C6	3-30p	Variable			900134	Mullard E7876
C7	68.5p	Variable			17274	Wingrove Rogers C28-241
C8	100p	Mica	350V	2	902161	Johnson Mathey C22F
C9	.01	Paper	500V	20	902333	Hunts W97/BM 21k
C10	1000p	Ceramic	350V	20	902122	Erie K350081AD

Cct. Ref.	Value	Description	Rat.	Tol. ± %	Racal Part No.	Manufacturer.
	<u>μF</u>	<u>Capacitors - Cont'd.</u>				
C11	10,000p	Ceramic	350V	20	902134	Erie K7500-12ED/PL107
C12	50p	Variable			906088	Wingrove Rogers C802/12/01
C13	220p	Mica	350V	2	902169	Johnson Mathey C22F
C14	8.2p	Ceramic	750V	½pF	902076	L.E.M.310N750
C15	3-30p	Variable			900134	Mullard E7876
C16	1000p	Ceramic	350V	20	902122	Erie K350081AD
C17	1000p	Ceramic	350V	20	902122	Erie K350081AD
C18	470p	Mica	350V	2	902171	Johnson Mathey C22F
C19	27.5p	Variable			906087	Wingrove Rogers C804/191
C20	1000p	Ceramic	350V	20	902122	Erie K350081AD
C21	0.01	Paper	500V	20	902333	Hunts W97/BM21k
C22	22p	Mica	350V	2	902145	Johnson Mathey C22F
C23	15p	Mica	350V	±1pF	902141	Johnson Mathey C22F
C24	220p	Mica	350V	2	902169	Johnson Mathey C22F
C25	0.01	Paper	500V	20	902333	Hunts W97/BM21k
C26	0.01	Paper	500V	20	902333	Hunts W97/BM21K
C27	10p	Ceramic	750V	5	900368	Erie P100K
C28	100p	Mica	350V	2	902161	Johnson Mathey C22F
C29	0.005	Paper	500V	20	902332	Hunts W97/BM20K
C30	2200p	Ceramic	350V	20	902126	L.E.M.310K
C31	1000p	Ceramic	350V	20	902122	Erie K350081AD
C32	47p	Mica	350V	2	902153	Johnson Mathey C22F
C33	47p	Mica	350V	2	902153	Johnson Mathey C22F
C34	1000p	Ceramic	350V	20	902122	Erie K350081AD
C35	12p	Mica	350V	±1pF	902139	Johnson Mathey C22F
C36	0.01	Paper	500V	20	902333	Hunts W97/BM21K
C37	0.05	Paper	250V	20	902328	Hunts W97/BM49K
C38	12	Electrolytic	250V		906112	Dubilier BR5140
C39	0.01	Paper	500V	20	902333	Hunts W97/BM21K
C40	0.01	Paper	500V	20	902333	Hunts W97/BM21K
C41	0.25		1000V	20	901452	Dubilier B1146
C42	10p	Mica	350V	2	902137	Johnson Mathey C22F
C43	0.01	Paper	500V	20	902333	Hunts W97/BM21K
C44	8.2p	Ceramic	750V	½pF	902010	L.E.M.310N750
C45	68p	Mica	350V	2	902157	S.T.C. 454/LWA/52

Cct. Ref.	Value	Description	Rat.	Tol. ± %	Racal Part No.	Manufacturer
	<u>μF</u>	<u>Capacitors - Cont'd.</u>				
C46	2-8p	Variable			901489	Mullard E7875
C47	68.5p	Variable			17274	Wingrove Rogers C28-241
C48	1000p	Ceramic	350V	20	902122	Erie K350081AD
C49	1000p	Ceramic	350V	20	902122	Erie K350081AD
C50	0.01	Paper	250V	20	902324	Hunts W97/BM13K
C51	1000p	Paper	350V	20	902122	Erie K350081AD
C52	0.01	Paper	500V	20	902333	Hunts W97/BM21K
C53	0.01	Paper	500V	20	902333	Hunts W97/BM21K
C54	150p	Mica	350V	2	902165	Johnson Mathey C22F
C55	22p	Mica	350V	2	902145	Johnson Mathey C22F
C56	120p	Mica	350V	2	902163	Johnson Mathey C22F
C57	1000p	Ceramic	350V	20	902122	Erie K350081AD
C58	0.01	Paper	500V	20	902333	Hunts W97/BM21K
C59	0.01	Paper	500V	20	902333	Hunts W97/BM21K
C60	100	Electrolytic	15V	-10% +50%	915675	Hunts AW 1421/A00
C61	470p	Mica	350V	2	902171	Johnson Mathey C22F
C62	0.01	Paper	500V	20	902333	Hunts W97/BM21K
C63	1000p	Ceramic	350V	20	902122	Erie K350081AD
C64	3900p	Mica	200V	2	902207	Johnson Mathey C22F
C65	0.01	Paper	500V	20	902333	Hunts W97/BM21K
C66	150p	Mica	350V	2	906241	Johnson Mathey C22F
C67	2-8p	Variable			901489	Mullard E7875
C68	1000p	Ceramic	350V	20	902122	L.E.M.310K
C70	220p	Mica	350V	2	902169	Johnson Mathey C22F
C71	10p	Mica	350V	2	902137	Johnson Mathey C22F
C72	0.01	Paper	500V	20	902333	Hunts W97/BM21K
C73	0.01	Paper	500V	20	902333	Hunts W97/BM21K
C74	15p	Mica	350V	2	902141	Johnson Mathey C22F
C75	0.01	Paper	500V	20	902333	Hunts W97/BM21K
C76	0.01	Paper	250V	20	902324	Hunts W97/BM13K
C77	82p	Mica	350V	2	902159	Johnson Mathey C22F
C78	8.2p	Mica	350V	2	905689	Johnson Mathey C22F
C79	0.01	Paper	250V	20	902324	Hunts W97/BM13K
C80	0.01	Paper	500V	20	902333	Hunts W97/BM21K
C81	2-8p	Variable			901489	Mullard E7875

Cct. Ref.	Value	Description	Rat.	Tol. ± %	Racal Part No.	Manufacturer.
	<u>μF</u>	<u>Capacitors - Cont'd.</u>				
C82	4.7p	Ceramic	750V	± $\frac{1}{2}$	902007	L.E.M.310P100
C83	0.01	Paper	250V	20	902324	Hunts W97/BM13K
C84	0.01	Paper	500V	20	902333	Hunts W97/BM21K
C85	220p	Mica	350V	2	902169	Johnson Mathey C22F
C86	27p	Mica	350V	2	902147	Johnson Mathey C22F
C87	3-30p	Variable			900492	Wingrove Rogers C31-01/1
C88	220p	Mica	350V	2	902169	Johnson Mathey C22F
C89	1000p	Mica	350V	2	902185	Johnson Mathey C22F
C90	220p	Mica	350V	2	902169	Johnson Mathey C22F
C91	1000p	Mica	350V	2	902185	Johnson Mathey C22F
C92	1000p	Ceramic	350V	20	902122	L.E.M. 310K
C93	82p	Mica	350V	2	902159	Johnson Mathey C22F
C94	220p	Mica	350V	2	902169	Johnson Mathey C22F
C95	1000p	Mica	350V	2	902185	Johnson Mathey C22F
C96	1000p	Ceramic	350V	20	902122	Erie K350081AD
C97	1000p	Ceramic	350V	20	902122	Erie K350081AD
C98	0.01	Paper	500V	20	902333	Hunts W97/BM21K
C99	12	Electrolytic	250V		906112	Dubilier BR5140
C100	1000p	Ceramic	350V	5	902122	Erie K350081AD
C101	1000p	Ceramic	350V	5	902122	Erie K350081AD
C102	0.01	Paper	500V	20	902333	Hunts W97/BM21K
C103	1000p	Ceramic	350V	5	902122	Erie K350081AD
C104	1000p	Mica	350V	2	902185	Johnson Mathey C22F
C105	1000p	Mica	350V	2	902185	Johnson Mathey C22F
C106	0.01	Paper	500V	20	902333	Hunts W97/BM21K
C107	1000p	Ceramic	350V		902122	Erie K350081AD
C108	47p	Mica	350V	2	902153	Johnson Mathey C22F
C109	47p	Mica	350V	2	902153	Johnson Mathey C22F
C110	1000p	Ceramic	350V	5	902122	Erie K350081AD
C111	12p	Mica	350V	±1p	902139	Johnson Mathey C22F
C112	1-10p	Variable			901490	Wingrove Rogers S55-13/1
C113	18.7p	Variable			906109	Wingrove Rogers C28-141
C114	5.6p	Ceramic	750V	± $\frac{1}{2}$ p	902074	L.E.M.310N750
C115	220p	Mica	350V	2	902169	Johnson Mathey C22F
C116	0.01	Paper	250V	20	902324	Hunts W97/BM13K

Cct. Ref.	Value	Description	Rat.	Tol. ± %	Racal Part No.	Manufacturer.
	<u>μF</u>	<u>Capacitors - Cont'd.</u>				
C117	0.01	Paper	250V		902324	Hunts W97/BM13K
C118	8.2p	Ceramic	750V	± $\frac{1}{2}$ P	902010	L.E.M.310N750
C119	1000p	Ceramic	350V	20	902122	Erie K350081AD
C120	0.01	Paper	500V	20	902333	Hunts W97/BM21K
C121	1000p	Ceramic	350V	20	902122	Erie K350081AD
C122	1000p	Mica	350V	2	902185	Johnson Mathey C22F
C123	1000p	Ceramic	350V	20	902122	Erie K350081AD
C124	220p	Mica	350V	2	902169	Johnson Mathey C22F
C125	1000p	Ceramic	350V	20	902122	Erie K350081AD
C126	47p	Ceramic	750V	2	900394	L.E.M.310N750
C127	100p	Variable			900493	Wingrove Rogers C1601-10/ 012/SLF
C128	30p	Variable			905553	Oxley A7/30
C129	1000p	Ceramic	350V	20	902122	Erie K350081AD
C130	1000p	Ceramic	350V	20	902122	Erie K350081AD
C132	0.01	Paper	250V	20	902324	Hunts W97/BM13K
C133	2	Electrolytic	500V		916015	Dubilier BR3505
C134	0.05	Paper	350V	25	902316	Hunts W49/B511K
C135	560p	Mica	350V	2	902179	Johnson Mathey C22F
C137	100p	Mica	350V	2	902161	Johnson Mathey C22F
C138	100p	Mica	350V	2	902161	Johnson Mathey C22F
C139	0.01	Paper	500V	20	902333	Hunts W97/BM21K
C141	.47	Polyester	160V	10	906937	Wima Tropyfol M..
C142	0.1	Paper	150V	25	902305	Hunts W49/B500K
C143	0.01	Paper	250V	25	902324	Hunts W97/BM13K
C144	0.01	Paper	250V	20	902324	Hunts W97/BM13K
C145	150p	Variable			906089	Wingrove Rogers C802-37/015
C146	100p	Mica	350V	2	902161	Johnson Mathey C22F
C147	1000p	Ceramic	350V	20	902122	Erie K350081AD
C148	33p	Mica	350V	2	902149	Johnson Mathey C22F
C149	47p	Mica	350V	2	902153	Johnson Mathey C22F
C151	180p	Mica	350V	2	902167	Johnson Mathey C22F
C152	1000p	Ceramic	350V	20	902122	Erie K350081AD
C153	4.7p	Ceramic	750V	± $\frac{1}{2}$ P	902007	L.E.M.310P100
C154	1000p	Mica	350V	2	902185	Johnson Mathey C22F
C155	0.01	Paper	250V	20	902324	Hunts W97/BM13K

Cct. Ref.	Value	Description	Rat.	Tol. ± %	Racal Part No.	Manufacturer.
	<u>μF</u>	<u>Capacitors - Cont'd.</u>				
C156	.01	Paper	250V	20	902324	Hunts W97/BM13K
C157	1000p	Ceramic	350V	20	902122	Erie K350081AD
C158	.01	Paper	250V	20	902324	Hunts W97/BM13K
C159	.01	Paper	250V	20	902324	Hunts W97/BM13K
C161	.01	Paper	500V	20	902333	Hunts W97/BM21K
C162	680p	Mica	350V	2	902181	Johnson Mathey C22F
C163	1000p	Ceramic	350V	20	902122	Erie K350081AD
C164	.01	Paper	500V	20	902333	Hunts W97/BM21K
C165	.01	Paper	500V	20	902333	Hunts W97/BM21K
C166	212px2	Ganged Variable				Racal AD15451
C168	6p	Trimmer			901987	Mullard MC004-EA/6E
C169	33p	Mica	350V	2	902149	Johnson Mathey C22F
C171	470p	Mica	350V	2	902171	Johnson Mathey C22F
C172	.01	Paper	500V	20	902333	Hunts W97/BM21K
C173	100p	Mica	350V	2	902161	Johnson Mathey C22F
C174	10p	Ceramic	750V	± $\frac{1}{2}$ p	902043	L.E.M.310P100
C175	10p	Ceramic	750V	± $\frac{1}{2}$ p	902043	L.E.M.310P100
C176	1000p	Ceramic	350V	20	902122	Erie K350081AD
C177	1000p	Ceramic	350V	20	902122	Erie K350081AD
C179	.01	Paper	500V	20	902333	Hunts W97/BM21K
C181	.01	Paper	500V	20	902333	Hunts W97/BM21K
C182	0.1	Paper	150V	25	902305	Hunts W49/B500K
C183	.01	Paper	500V	20	902333	Hunts W97/BM21K
C184	.01	Paper	500V	20	902333	Hunts W97/BM21K
C186	22p	Mica	350V	2	902145	Johnson Mathey C22F
C187	22p	Mica	350V	2	902145	Johnson Mathey C22F
C188	1000p	Ceramic	350V	20	902122	Erie K350081AD
C189	15p	Mica	350V	± $\frac{1}{2}$ p	902141	Johnson Mathey C22F
C190	32	Electrolytic	350V		900084	Plessey CE818/1
C192	1	Paper	350V	20	902320	Hunts W49/B515K
C193	.01	Paper	500V	20	902333	Hunts W97/BM21K
C194	.25	Paper	150V	25	902306	Hunts W49/B501K
C195	2	Electrolytic	500V		916015	Dubilier BR3505
C196	32	Electrolytic (Part of C190)				
C197	32	Electrolytic	50/230V		915671	Dubilier SCT3544

Cct. Ref.	Value	Description	Rat.	Tol. ± %	Racal Part No.	Manufacturer.
	<u>μF</u>	<u>Capacitors - Cont'd.</u>				
C198	100	Electrolytic	50V		900506	Hunts L37/1-ME-FC43T
C199	.01	Paper	500V	20	902333	Hunts W97/BM21K
C201	1000p	Ceramic	350V	20	902122	Erie K350081AD
C202	.05	Paper	350V	25	902316	Hunts W49/B511K
C203	1000p	Ceramic	350V	20	902122	Erie K350081AD
C204	.01	Paper	500V	20	902333	Hunts W97/BM21K
C205	.01	Paper	500V	20	902333	Hunts W97/BM21K
C206	82p	Mica	350V	2	902159	Johnson Mathey C22F
C207	.1	Paper	150V	25	902305	Hunts W49/B500K
C208	.01	Paper	500V	20	902333	Hunts W97/BM21K
C209	.01	Paper	500V	20	902333	Hunts W97/BM21K
C211	100	Electrolytic			900506	Hunts L37/1-MEFC43T
C212	680p	Mica	350V	2	902181	Johnson Mathey C22F
C213	1	Paper	150V	20	902308	Hunts W49/B503K
C214	212p	Part of C166				
C215	.01	Paper	500V	20	902333	Hunts W97/BM21K
C216	1000p	Ceramic	350V	20	902122	Erie K350081AD
C217	100p	Mica	350V	2	902161	Johnson Mathey C22F
C218	150p	Mica	350V	2	902165	Johnson Mathey C22F
C219	150p	Mica	350V	2	902165	Johnson Mathey C22F
C221	120p	Mica	350V	2	902163	Johnson Mathey C22F
C222	100p	Mica	350V	2	902161	Johnson Mathey C22F
C223	.01	Paper	500V	20	902333	Hunts W97/BM21K
C224	47p	Ceramic	350V	2	902153	Johnson Mathey C22F
C225	220p	Ceramic	350V	2	902169	Johnson Mathey C22F
C227	2	Electrolytic	500V		916015	Dubilier BR3505
C229	.01	Paper	500V	20	902333	Hunts W97/BM21K
C231	.01	Ceramic	350V	20	902134	Erie 750012BD
C232	.01	Ceramic	350V	20	902134	Erie 750012BD
C233	10p	Trimmer			900491	Wingrove Rogers C32-01
C234	10p	Ceramic	750V	5	900368	Erie P100K
C235	10p	Ceramic	750V	5	900368	Erie P100K
C236	.01	Paper	250V	20	902324	Hunts W97/BM13K
C237	47p	Mica	350V	±1pF	908202	Johnson Mathey C22F
C238	100p	Mica	350V	±2pF	908156	Johnson Mathey C22F

Cct. Ref.	Value	Description	Rat.	Tol. ±%	Racal Part No.	Manufacturer.
	<u>μF</u>	<u>Capacitors - Cont'd.</u>				
C239	175p	Mica	350V	±3pF	907845	Johnson Mathey C22F
C241	300p	Mica	350V	±1%	910804	Johnson Mathey C22F
C242	33p	Mica	350V	2	902149	Johnson Mathey C22F
C243	1.5-18p	Trimmer	1000V		900424	Oxley A15/13-2
C244	1000p	Mica	350V	2	902185	Johnson Mathey C22F
C245	1.5-18p	Trimmer	1000V		900424	Oxley A15/13-2
C246	39p	Mica	350V	2	902151	Johnson Mathey C22F
C247	1.5-18p	Trimmer	1000V		900424	Oxley A15/13-2
C248	39p	Mica	350V	2	902151	Johnson Mathey C22F
C249	1000p	Mica	350V	2	902185	Johnson Mathey C22F
C251	1.5-18p	Trimmer	1000V		900424	Oxley A15/13-2
C252	22p	Mica	350V	2	902145	Johnson Mathey C22F
C253	1.5-18p	Trimmer	1000V		900424	Oxley A15/13-2
C254	33p	Mica	350V	2	902149	Johnson Mathey C22F
C255	1.5-18p	Trimmer	1000V		900424	Oxley A15/13-2
C256	33p	Mica	350V	2	902149	Johnson Mathey C22F
C257	1000p	Ceramic	350V	20	902122	Erie K350081AD
C258	2.7p	Ceramic	750V	± $\frac{1}{2}$ pF	900366	L.E.M.310P750
C259	14.7p	Ceramic		10	901052	Erie N750K
C261	14.7p	Ceramic		10	901052	Erie N750K
C262	14.7p	Ceramic		10	901052	Erie N750K
C263	0.01	Paper	500V	20	902333	Hunts W97/BM21K
C264	1000p	Ceramic	350V	20	902122	Erie K350081AD
C265	1000p	Ceramic	350V	20	902122	Erie K350081AD
C266	1000p	Ceramic	350V	20	902122	Erie K350081AD
C267	1000p	Ceramic	350V	20	902122	Erie K350081AD
C268	1000p	Ceramic	350V	20	902122	Erie K350081AD
C269	1000p	Ceramic	350V	20	902122	Erie K350081AD
C271	0.01	Paper	500V	20	902333	Hunts W97/BM21K
C272	0.25	Paper	150V	20	902306	Hunts W49/B501K
C273	1000p	Ceramic	350V	20	902122	Erie K350081AD
C274	10p	Ceramic	750V	5	900368	Erie P100K
C275	10p	Ceramic	750V	5	900368	Erie P100K
C276	10p	Ceramic	750V	5	900368	Erie P100K
C277	12p	Mica	350V	±1pF	913431	Johnson Mathey C22F

Cct. Ref.	Value	Description	Rat.	Tol. ± %	Racal Part No.	Manufacturer.
<u>µF</u> <u>Capacitors - Cont'd.</u>						
C278	53p	Mica	350V	±2pF	905198	Johnson Mathey C22F
C279	168p	Mica	350V	±3pF	906142	Johnson Mathey C22F
C281	1.5-18p	Trimmer	1000V		900424	Oxley A15/13-2
C282	39p	Mica	350V	2	902151	Johnson Mathey C22F
C283	1.5-18p	Trimmer	1000V		900424	Oxley A15/13-2
C284	39p	Mica	350V	2	902151	Johnson Mathey C22F
C285	1.5-18p	Trimmer	1000V		900424	Oxley A15/13-2
C286	33p	Mica	350V	2	902149	Johnson Mathey C22F
C287	1.5-18p	Trimmer	1000V		900424	Oxley A15/13-2
C288	14.7p	Ceramic		10	901052	Erie N750K
C289	14.7p	Ceramic		10	901052	Erie N750K
C291	1000p	Ceramic	350V	20	902122	Erie K350081AD
C292	1.5-18p	Trimmer	1000V		900424	Oxley A15/13-2
C293	39p	Mica	350V	2	902151	Johnson Mathey C22F
C294	1.5-18p	Trimmer	1000V		900424	Oxley A15/13-2
C295	39p	Mica	350V	2	902151	Johnson Mathey C22F
C296	1.5-18p	Trimmer	1000V		900424	Oxley A15/13-2
C297	33p	Mica	350V	2	902149	Johnson Mathey C22F
C298	220p	Mica	350V	2	902169	Johnson Mathey C22F
C299	33p	Mica	350V	2	902149	Johnson Mathey C22F
C301	1.5-18p	Trimmer	1000V		900424	Oxley A15/13-2
C302	33p	Mica	350V	2	902149	Johnson Mathey C22F
C303	1.5-18p	Trimmer	1000V		900424	Oxley A15/13-2
C304	33p	Mica	350V	2	902149	Johnson Mathey C22F
C305	1.5-18p	Trimmer	1000V		900424	Oxley A15/13-2
C306	15p	Mica	350V	±1pF	902141	Johnson Mathey C22F
C307	14.7p	Ceramic		10	901052	Erie N750K
C308	0.1	Paper	500V	20	902294	Hunts L45/B407K
C309	0.1	Paper	500V	20	902294	Hunts L45/B407K
C310	470p	Mica	350V	2	902171	Johnson Mathey C22F
C312	0.01	Paper	250V	20	902324	Hunts W97/BM13K
C313	5000p	Ceramic	350V	10	900752	Erie K350081AD
C314	1000p	Ceramic	350V	10	902122	Erie K350081AD
C315	1000p	Ceramic	350V	20	902122	Erie K350081AD
C316	0.1	Paper	150V	25	902305	Hunts W49/B500K
C319	0.01	Paper	250V	20	902324	Hunts W97/BM13K

Cct. Ref.	Value	Description	Rat.	Tol. ± %	Racal Part No.	Manufacturer.
	μF	<u>Capacitors - Cont'd.</u>				
C320	2200p	Ceramic	350V	20	902126	Erie K350081AD
1C1	1.5-11p	Trimmer			906274	Erie 3116Z
1C2	1.5-11p	Trimmer			906274	Erie 3116Z
1C3	5.6p	Mica	750V	± $\frac{1}{2}$ pF	902074	L.E.M.310NPO
1C4	4.7p	Mica	750V	± $\frac{1}{2}$ pF	902007	L.E.M.310NPO
1C5	1.5-11p	Trimmer			906274	Erie 3116Z
1C6	1.5-11p	Trimmer			906274	Erie 3116Z
1C7	1000p	Mica	350V	2	902185	Johnson Mathey C22F
1C8	1000p	Mica	350V	2	902185	Johnson Mathey C22F
1C9	22p	Ceramic	750V	5	902085	L.E.M.310N750
1C10	1000p	Mica	350V	2	902185	Johnson Mathey C22F
		Superseded by L.S.B. Filter				
1C11	1000p	Mica	350V	2	902185	Johnson Mathey C22F
1C12	82p	Mica	350V	2	902159	Johnson Mathey C22F
1C13	82p	Mica	350V	2	902159	Johnson Mathey C22F
1C14	18p	Ceramic	750V	5	902083	L.E.M.310N750
1C15	18p	Ceramic	750V	5	902083	L.E.M.310N750
1C16	22p	Ceramic	750V	5	902085	L.E.M.310N750
1C17	5.6p	Mica	750V	± $\frac{1}{2}$ pF	902074	L.E.M.310NPO
1C18	180p	Mica	350V	2	902167	Johnson Mathey C22F
1C19	180p	Mica	350V	2	902167	Johnson Mathey C22F
2C1	1.5-11p	Trimmer			906274	Erie 3116Z
2C2	1.5-11p	Trimmer			906274	Erie 3116Z
2C3	5.6p	Mica	750V	± $\frac{1}{2}$ pF	902074	L.E.M.310NPO
2C4	4.7p	Mica	750V	± $\frac{1}{2}$ pF	902007	L.E.M.310NPO
2C5	1.5-11p	Trimmer			906274	Erie 3116Z
		Superseded by U.S.B. Filter				

Cct. Ref.	Value	Description	Rat.	Tol. ±%	Racal Part No.	Manufacturer.
	μF	<u>Capacitors - Cont'd.</u>				
2C6	1.5-11p	Trimmer			906274	Erie 3116Z
2C7	1000p	Mica	350V	5	902185	Johnson Mathey C22F
2C8	1000p	Mica	350V	5	902185	Johnson Mathey C22F
2C9	22p	Ceramic	750V	5	902085	L.E.M.310N750
2C10	1000p	Mica	350V	5	902185	Johnson Mathey C22F
2C11	1000p	Mica	350V	5	902185	Johnson Mathey C22F
2C12	82p	Mica	350V	5	902159	Johnson Mathey C22F
2C13	82p	Mica	350V	5	902159	Johnson Mathey C22F
2C14	18p	Ceramic	750V	5	902083	L.E.M.310N750
2C15	18p	Ceramic	750V	5	902083	L.E.M.310N750
2C16	22p	Ceramic	750V	5	902085	L.E.M.310N750
2C17	180p	Ceramic	350V	5	902167	Johnson Mathey C22F
2C18	180p	Ceramic	350V	5	902167	Johnson Mathey C22F

INDUCTORS

L1	Coil XTal Anode (1Mc/s)	Racal AA4768
L2	Coil Assembly	Racal AA14671
L3	Reactance Valve Grid	Racal AA14670
L6	Coil Assembly	Racal AA16033
L7	Transformer Assembly	Racal BT14839
L8	Coil Assembly	Racal BA15161
L10	Choke	Racal AD16987
L13	Doubler Coil Assembly (10Mc/s)	Racal BA14674
L14	Coil Assembly	Racal AA14959
L15	Mixer Coil Assembly (1.6 Mc/s)	Racal BA14676
L17	Mixer Anode (37.5 Mc/s)	Racal AA4763
L18	Balanced Modulator Coil (MA.79G)	Racal BA22409
L18	Balanced Modulator Coil (MA.79A)	Racal BA14673

Cct. Value Ref.	Description	Rat.	Tol. ± %	Racal Part No.	Manufacturer.
-----------------	-------------	------	----------	----------------	---------------

Inductors - Cont'd.

L19	Key Valve Anode Coil Assembly (1.6Mc/s)			Racal BA14672	
L20	Coil Assembly			Racal AA14671	
L21	Amplifier Anode (37.5 Mc/s)			Racal AA4763	
L23	Tapped Anode Coil (37.5 Mc/s)			Racal AA4772	
L24	Coil Assembly			Racal AA16033	
L25	Doubler Coil Assembly (10.2 Mc/s)			Racal BA14675	
L28	Coil Assembly			Racal AA4759	
L29	Coil Assembly			Racal AA16819	
L31	Coil Assembly (10 kc/s)			Racal BA16537	
L32	V.F.O. Anode Coil Assembly			Racal AA4780	
L33	Coil Assembly			Racal AA15370	
L34	Mixer Coil Assembly (11.6 Mc/s)			Racal BA14677	
L35	Choke			Racal AD16987	
L36	Coil - Calibrator (100 Kc/s)			Racal AA4777	
L37	Coil Assembly			Racal BA17098	
L38	Choke D.C. Res. 100ohms			Parmeko P.486	
L39	R.F. Coil Assembly (1.5-3 Mc/s)			Racal AA14295	
L41	R.F. Coil Assembly (3-6 Mc/s)			Racal AA14296	
L42	R.F. Coil Assembly (6-12 Mc/s)			Racal AA14297	
L43	R.F. Coil Assembly (12-20 Mc/s)			Racal AA14298	
L44	R.F. Coil Assembly (20-30 Mc/s)			Racal AA14299	
L45	Coil - Calibrator (900 kc/s)			Racal AA 4779	
L46	Choke			Racal AD16987	
L47	R.F. Coil Assembly (1.5-3 Mc/s)			Racal AA14295	
L48	R.F. Coil Assembly (3-6 Mc/s)			Racal AA14296	
L49	R.F. Coil Assembly (6-12 Mc/s)			Racal AA14297	
L51	R.F. Coil Assembly (12-20 Mc/s)			Racal AA14298	
L52	R.F. Coil Assembly (20-30 Mc/s)			Racal AA14299	
L53	Coil Assembly (1.6 Mc/s)			Racal BA15392	
L54	Coil Assembly (1.4 Mc/s)			Racal BA15379	
L55	Coil Assembly			Racal BT4 1088	
L56	Coil Assembly			Racal BT4 1089	
L57	Coil Assembly			Racal BT4 1093	
L58	Coil Assembly			Racal AA4761	
L59	Coil Assembly			Racal AA4761	

Oct. Ref.	Value	Description	Rat.	Tol. ± %	Racal Part No.	Manufacturer.
--------------	-------	-------------	------	-------------	-------------------	---------------

Inductors - Cont'd.

L60		Coil Assembly			Racal AA4632	
L61		Coil Assembly			Racal AA4632	
L62		Filter (0-30 Mc/s)			Racal BD4586	
L63		Common with L62				
L64		Choke			Racal AD16987	
L65		Filter Coil Assembly			Racal AA4655	
L66		Filter			Racal AA4760	
L67		Filter			Racal AA4760	
L68		Choke			Racal AD16987	
L69		Filter Coil Assembly			Racal AA4655	
L71		Harmonic Filter			Racal AD4589	
L72		Common with L71				
L73		Common with L71				
L74		Common with L71				
L75		Common with L71				
L76		Common with L71				
L77		Coil Assembly			Racal BT41094	
L78		Coil Assembly			Racal BT41090	
L79		Coil Assembly			Racal BT41091	
L81		Coil Assembly			Racal AA4761	
L82		Coil Assembly			Racal AA4761	
L83		Coil Assembly			Racal AA4632	
L84		Common with L62				
L85		Common with L62				
L86		Common with L71				
L87		Coil Assembly			Racal BT41092	
L88		Coil Assembly			Racal AA4761	
L89		Coil Assembly			Racal AA4761	
L91		Coil Assembly			Racal AA4632	
L92		Coil Assembly			Racal AA4632	
L93		Common with L62				
L94		Common with L62				
L95		Common with L62				
L96		Coil Assembly			Racal AA4761	
L97		Coil Assembly			Racal AA4761	

Cct. Ref.	Description	Rat.	Tol. ± %	Racal Part No.	Manufacturer.
-----------	-------------	------	-------------	----------------	---------------

Inductors - Cont'd.

L98	Coil Assembly			Racal AA4632	
L99	Coil Assembly			Racal AA4632	
L100	Coil Assembly			Racal AA4632	
L101	Filter Coil Assembly			Racal AA4655	
L102	Filter Coil Assembly			Racal AA4655	
L103	Choke			Racal AD16987	
L104	Choke			Bulgin C502	
L11	Coil Assembly	} Superseded by	} L.S.B. Filter	Racal AA15133	
L12	Coil Assembly			Racal AA15133	
2L1	Coil Assembly	} Superseded by	} U.S.B. Filter	Racal AA15133	
2L2	Coil Assembly			Racal AA15133	

TRANSFORMERS

T1	Mains Transformer			Racal BT14138	
1T1	Coil Assembly	} Superseded by	} L.S.B. Filter	Racal AA15058	
1T2	Coil Assembly			Racal AA15139	
2T1	Coil Assembly	} Superseded by	} U.S.B. Filter	Racal AA15058	
2T2	Coil Assembly			Racal AA15139	

CRYSTALS

XL1	Crystal, style D			Racal AD17303	
XL2	Crystal, style D			Racal AD17303	
XL3	Crystal, style D			Racal AD17303	
XL4	Crystal, style D			Racal AD17303	
XL5	Crystal, style D			Racal AD17303	
XL6	Crystal, style D			Racal AD17303	
XL7	Crystal (1Mc/s) style D			Racal BD16531	
XL8	Crystal (5Mc/s) style D			Racal BD16052/A	
XL9	Crystal (5.1 Mc/s) style D			Racal BD16052	
1XL1	Crystal (1396.5 kc/s)	} Superseded by	} L.S.B. Filter	Racal CT37364/12	
1XL2	Crystal (1399.6 kc/s)			Racal CT37364/3	
1XL3	Crystal (1396.5 kc/s)			Racal CT37364/12	
1XL4	Crystal (1399.6 kc/s)			Racal CT37364/3	

Cct. Value Ref.	Description	Rat.	Tol. ± %	Racal Part No.	Manufacturer.
-----------------	-------------	------	----------	----------------	---------------

Valves - Cont'd.

V26	Pentode, E180F				CV3998
V27	Pentode, 6BE6				CV453
V28	Pentode, 6BA6				CV454
V29	Pentode, EF91				CV138
V30	Pentode, EL821				CV2127
V31	Pentode, EF91				CV138
V32	Pentode, EF91				CV138
V33	Pentode, 6AS6				CV2522
D1	Diode, OA90			905396	
D2	Diode, SJ.403F			901533	CV8532
D3	Diode, Z2A150F			906096	CV7098
D4	Diode, SJ.403F			901533	CV8532
D5	Diode, SJ.403F			901533	CV8532
D6	Diode, SJ.403F			901533	CV8532
D7	Diode, SJ.403F			901533	CV8532
D8	Diode, SJ.403F			901533	CV8532

SWITCHES

SA	XTAL-V.F.O.				Racal BSW14868
SB1	TRANSMISSION SELECTOR				Racal BSW14592
SE2+3	TRANSMISSION SELECTOR				Racal BSW14593
SC4	TRANSMISSION SELECTOR				Racal BSW15480
SC	INPUT				Racal BSW14399
SD	MAN.AUTO. (D.P.C.O.)				Z510554
SE1	SIDEBAND - MA.79G				Racal BSW22421
SE1	SIDEBAND - MA.79A				Racal BSW14406
SE2	SIDEBAND - MA.79G				Racal BSW22422
SE2	SIDEBAND - MA.79A				Racal BSW14407
SF	OUTPUT RANGE MC/S				Racal BSW15003
SG	METER +14DB				Painton 501404
SH	METER (D.P.C.O.)				Z510554
SJ	CALIBRATE				Racal BSW14610
SK	POWER ON/OFF (D.P.C.O.)				Z510554

Cct. Ref.	Value	Description	Rat.	Tol. ± %	Racal Part No.	Manufacturer.
<u>PLUGS</u>						
PL1		Mains, fixed			900507	Plessey Mk IV CZ48993
PL2		Coaxial, R.F. OUTPUT			900351	
PL3		Coaxial			900510	Magnetic Devices 732564
PL4		Coaxial			900510	Magnetic Devices 732564
PL5		Coaxial			900510	Magnetic Devices 732564
PL6		Coaxial			900351	
PL7		Coaxial			900510	Magnetic Devices 732564
PL8		Coaxial			900351	
PL9		Coaxial			900510	Magnetic Devices 732564
PL10		Coaxial			900510	Magnetic Devices 732564
PL11		Coaxial			900510	Magnetic Devices 732564
PL12		Coaxial			900510	Magnetic Devices 732564
PL13		Coaxial			900510	Magnetic Devices 732564
PL14		Coaxial EXT. XTAL			900509	
PL15		12-way, Unitor, fixed			906084	Belling Lee L655P
PL16*		Coaxial, 1MC/S IN			900509	
PL17		Coaxial, 1.4 MC/S IN (MA.79G)			900509	
PL18		Coaxial, (MA.79G)			900510	Magnetic Devices 732564
PL19		Coaxial, (MA.79G)			900510	Magnetic Devices 732564
PL20		Coaxial, 1.4 MC/S OUT (MA.79G)			900510	Magnetic Devices 732564

SOCKETS

SKT1		Mains, free				Plessey Mk.IV Z560100
		Outlet accessory set for SKT1				Plessey Mk.IV 2CZ108111
SKT2		Coaxial, R.F. OUTPUT? free			900350	
		Inner sleeve for SKT2			900490	
		Outer sleeve for SKT2			900355	
SKT3		Coaxial, free, including sleeves			905465	Magnetic Devices 736023
SKT4		Coaxial, free, including sleeves			901362	Magnetic Devices 9580020

* If fitted.

Cct. Ref.	Value	Description	Rat.	Tol. ± %	Racal Part No.	Manufacturer.
<u>Sockets - Cont'd.</u>						
SKT5		Coaxial				Refer to SKT3
SKT6		Coaxial				Refer to SKT4
SKT7		Coaxial				Refer to SKT4
SKT8		Coaxial				Refer to SKT3
SKT9		Coaxial				Refer to SKT3
SKT10		Coaxial				Refer to SKT4
SKT11		Coaxial				Refer to SKT3
SKT12 & 13		Coaxial				Refer to SKT3
SKT15		12-way Unitor, free			905697	Belling Lee L655S.
SKT18		Coaxial (MA.79G)				Refer to SKT3
SKT19		Coaxial				Refer to SKT4

MISCELLANEOUS

Six-Channel Crystal Oven Assembly (Oven 1)						Racal CA14960
Thermometer for the above oven assembly						Racal AA20078
Kc/s V.F.O. Assembly						Racal CA15280
Modulator assembly						Racal DA15020
Upper Sideband Crystal Filter Assembly						Racal BD43683/4
Lower Sideband Crystal Filter Assembly						Racal BD43683/3
Mc/s V.F.O. Assembly						Racal CA15002
Lamp (8V, 1.6W)				900355		Luxram 983 (M.E.S.)
Tool rack Assembly comprising :						Racal BA17852
Trimming tool						Racal AD7955
Trimming tool				901315		Millard T.C.T.01
Wrench				900358		Unbrako W6
Wrench				901287		Unbrako W3
Wrench				900357		Unbrako W1
Screwdriver				901320		
Crystal Oven 3 Assembly						Cathodeon Crystals Type D4
Calibrator Assembly						Racal CA15411
Voltage Selector (plug)						Racal AD11999/A
Voltage Selector (socket)						Racal AB11999/B
Crystal Oven 2 Assembly						James Knight 905-7531, 8W, 75°C, 115V.

Cct. Ref.	Value	Description	Rat.	Tol. ± %	Racal Part No.	Manufacturer.
--------------	-------	-------------	------	-------------	-------------------	---------------

Miscellaneous - Cont'd.

		Jack Socket				Bulgin J2
RLA/1		Relay (48-volt)			906076	S.T.C.4190HE
RLB/2		Relay (24-volt)			901992	S.T.C.4190GD
FS1		Fuse (500mA)			901317	Belling Lee L1055
FS2		Fuse (3A)			901108	Belling Lee L1055
		Film Scale				Racal CD14971

CHAPTER 6

LIST OF N.A.T.O. STOCK NUMBERS.

Cct. Ref.	N.A.T.O. Stock No.	Cct. Ref.	N.A.T.O. Stock No.	Cct. Ref.	N.A.T.O. Stock No.	Cct. Ref.	N.A.T.O. Stock No.
<u>RESISTORS</u>							
5905-99-							
R1	022-2090	R34	022-2090	R65	022-1001	R96	022-2193
R2	022-3037	R35	022-2214	R66	022-1001	R97	
R3	022-2193	R36	022-3163	R67	022-2130	R98	022-3079
R4	022-3037	R37	022-2130	R68	022-2046	R99	022-1151
R5	022-1205	R38	022-1151	R69	022-1151	R100	022-2214
R6	022-2172	R40	022-1048	R70	022-2121	R101	022-3037
R8	021-6092	R42	022-3163	R71	022-2046	R102	022-3121
R9	022-2172	R44	022-2004	R72	022-2172	R103	022-2214
R11	022-1172	R45	022-1193	R73	022-3079	R104	011-3329
R12	022-3121	R46	022-3121	R74	021-6021	R105	022-1214
R13	022-2214	R47	022-2130	R75	022-2058	R106	022-2151
R16A	022-2193	R48	022-1001	R76	022-2004	R107	022-1001
R16B	022-2193	R49	022-2046	R77	022-2123	R108	022-3037
R17	022-2130	R50	022-1214	R78	021-5121	R109	022-1088
R18	022-2130	R51	022-1151			R110	022-2004
R19	022-2186	R52	021-6001			R110A	022-2004
R21	022-3037	R53A	022-2195	R81	021-5121	R111	022-2004
R22	022-2172	R53B	022-2195	R82	022-2130	R112	022-1193
R23	022-2088	R54A	022-2079	R83	022-2151	R113	022-2004
R24	022-2006	R54B	022-2037	R84	022-1046	R115	022-2214
R25		R55	022-3121	R85	022-1001	R116	022-1001
R26	022-3018	R56	022-2214	R86	022-1130	R117	022-2046
R26A	022-3018	R56A	022-2195	R87	022-3121	R118	022-2172
R27	022-2195	R57	022-2004	R88	022-1079	R119	022-2174
R28	022-2193	R58	022-2172	R89	022-1193	R120	022-2193
R29	022-2214	R59	021-5242	R90	021-5241	R121	022-3016
R30	022-2121	R60	022-1001	R91	022-2130	R122	022-2088
R31	022-2172	R62	022-1088	R93	022-2214	R123	022-1100
R32	022-1151	R63	022-2004	R94	022-1001	R124	022-1142
R33	022-3079	R64	022-2004	R95	022-1130	R125	022-2172
						R126	022-3163

Cct. Ref.	N.A.T.O. Stock No.	Cct. Ref.	N.A.T.O. Stock No.	Cct. Ref.	N.A.T.O. Stock No.	Cct. Ref.	N.A.T.O. Stock No.
-----------	--------------------	-----------	--------------------	-----------	--------------------	-----------	--------------------

Resistors, cont'd

5905-99-

R128	022-2172	R147	022-2088	R167	022-3060	R187	022-1214
R129	022-3016	R148	022-1151	R168	022-2172	R188	022-1172
R129A	022-2195	R149	022-2172	R169	022-2186	R189	022-1142
R131	022-2195	R151	022-3163	R171	022-3039	R190	022-2004
R132	021-5332	R152	022-3163	R172	022-3039	R191	022-3007
R133	022-1214	R153	022-2004	R174	022-3163	R193	022-2046
R134	022-3079	R154	022-2132	R175	022-3079	R194	022-3142
R135	022-1151	R155	022-2130	R177	022-3016	R195	022-3058
R136	022-2172	R156	022-2130	R178	011-3447	R196	011-3377
R137	022-2123	R157	022-3037	R179	021-9245	R197	022-2004
R138	022-2123	R158	022-2216	R180	022-2174	R198	022-1193
R139	022-2174	R159	022-3016	R181	021-9179	1R1	022-3037
R141	022-1088	R161	011-3487	R182	011-3479	1R2	022-3079
R143	022-2046	R163	022-1123	R183	022-2006	2R1	022-3037
R144	022-2048	R164	022-1067	R184	022-1111	2R2	022-3079
R145	022-2174	R165	022-1109	R185	022-1088	RV1	
R146	022-3018	R166	022-2046	R186	021-5281	RV2	
						RV3	

CAPACITORS

5910-99-

C1	016-7006	C16	954-0635	C31	954-0635	C46	016-7002
C2	016-7006	C17	954-0635	C32	970-6633	C47	103-5728
C3	016-7006	C18	519-1072	C33	970-6633	C48	954-0635
C4	016-7006	C19		C34	954-0635	C49	954-0635
C5	016-7006	C20	954-0635	C35	103-6828	C50	012-0113
C6	016-7006	C21	012-0123	C36	012-0123	C51	954-0635
C7	103-5728	C22	103-3628	C37	012-0600	C52	012-0123
C8	972-7386	C23	911-6975	C38		C53	012-0123
C9	012-0123	C24	972-7874	C39	012-0123	C54	972-9056
C10	954-0635	C25	012-0123	C40	012-0123	C55	103-3628
C11	954-0635	C26	012-0123	C41	580-7211	C56	972-7765
C12	016-0018	C27	911-5390	C42	103-6827	C57	954-0635
C13	972-7874	C28	972-7386	C43	012-0123	C58	012-0123
C14	Z0118601	C29	012-0122	C44	011-8347	C59	012-0123
C15	016-7006	C30	103-3676	C45	104-0900	C60	

Cct. Ref.	N.A.T.O. Stock No.	Cct. Ref.	N.A.T.O. Stock No.	Cct. Ref.	N.A.T.O. Stock No.	Cct. Ref.	N.A.T.O. Stock No.
<u>Capacitors, cont'd</u>							
5910-99-							
C61	519-1072	C97	954-0635	C133		C174	011-9974
C62	012-0123	C98	012-0123	C134	011-5559	C175	011-9974
C63	954-0635	C99	580-5558	C135		C176	954-0635
C64	953-2394	C100	954-0635	C137	972-7386	C177	954-0635
C65	012-0123	C101	954-0635	C138	972-7386	C179	012-0123
C66	972-9056	C102	012-0123	C139	012-0123	C181	012-0123
C67		C103	954-0635			C182	011-5560
C69	954-0635	C104	972-2489	C142	011-5560	C183	012-0123
C70	972-7874	C105	972-2489	C143	012-0113	C184	012-0123
C71	103-6827	C106	012-0123	C144	012-0113	C186	103-3628
C72	012-0123	C107	954-0635	C145	016-0011	C187	103-3628
C73	012-0123	C108	970-6633	C146	972-7386	C188	954-0635
C74	911-6975	C109	970-6633	C147	954-0635	C189	103-6829
C75	012-0123	C110	954-0635	C148	972-1113	C190	103-5730
C76	012-0123	C111	103-6828	C149	970-6633	C192	011-5571
C77	580-0139	C112	580-5177	C151	519-1069	C193	012-0123
C78		C113		C152	954-0635	C194	011-5563
C79	012-0113	C114	011-8599	C153	011-8344	C195	
C80	012-0123	C115	972-7874	C154	972-2489	C196	Part of C19
C81	016-7002	C116	012-0113	C155	012-0113	C197	
C82	011-8344	C117	012-0113	C156	012-0113	C198	972-2497
C83	012-0113	C118	011-8347	C157	954-0635	C199	012-0123
C84	012-0123	C119	954-0635	C158	012-0113	C201	954-0635
C85	972-7874	C120	012-0123	C159	012-0113	C202	011-5559
C86	970-6634	C121	954-0635	C161	012-0123	C203	954-0635
C87	016-0047	C122	972-2489	C162	972-1379	C204	012-0123
C88	972-7874	C123	954-0635	C163	954-0635	C205	012-0123
C89	972-2489	C124	972-7874	C164	012-0123	C206	580-0139
C90	972-7874	C125	954-0635	C165	012-0123	C207	011-5560
C91	972-2489	C126	970-6633	C166	914-3576	C208	012-0123
C92	954-0635	C127	972-8324	C168	580-2484	C209	012-0123
C93	580-0139	C128	016-0047	C169	972-1113	C211	972-2497
C94	972-7874	C129	954-0635	C171	519-1072	C212	972-1379
C95	972-2489	C130	954-0635	C172	012-0123	C213	011-5569
C96	954-0635	C132	012-0113	C173	972-7386	C214	See C166

Cct. Ref.	N.A.T.O. Stock No.	Cct. Ref.	N.A.T.O. Stock No.	Cct. Ref.	N.A.T.O. Stock No.	Cct. Ref.	N.A.T.O. Stock No.
<u>Capacitors, cont'd</u>							
5910-99-							
C215	012-0123	C256	972-1113	C295		1C11	972-2489
C216	954-0635	C257	954-0635	C296	972-8322	1C12	580-0139
C217	972-7386	C258		C297	972-1113	1C13	580-0139
C218	911-9056	C259	972-2563	C298	972-7874	1C14	011-8608
C219	911-9056	C261	972-2563	C299	972-1113	1C15	011-8608
C221	972-7765	C262	972-2563	C301	972-8322	1C16	011-8610
C222	972-7386	C263	012-0123	C302	972-1113	1C17	011-8599
C223	012-0123	C264	954-0635	C303	972-8322	1C18	519-1069
C224	970-6633	C265	954-0635	C304	972-1113	1C19	519-1069
C225	972-7874	C266	954-0635	C305	972-8322		
C227		C267	954-0635	C306	911-6975		
C229	012-0123	C268	954-0635	C307	972-2563		
C231		C269	954-0635	C308	011-5507		
C232		C271	012-0123	C309	011-5507		
C233	911-4011	C272	011-5563	C310	519-1072		
C234	911-5390	C273	954-0635	C312	012-0113		
C235	911-5390	C274	911-5390	C313			
C236	012-0113	C275	911-5390	C314	954-0635	2C1	972-7772
C237		C276	911-5390	C315	954-0635	2C2	972-7772
C238		C277	972-1844	C316	011-5560	2C3	011-8599
C239		C278		C319	012-0113	2C4	011-8344
C241		C279		C320	954-0635	2C5	972-7772
C242	972-1113	C281	972-8322			2C6	972-7772
C243	972-8322	C282				2C7	972-2489
C244	972-2489	C283	972-8322			2C8	972-2489
C245	972-8322	C284		1C1	972-7772	2C9	011-8610
C246		C285	972-8322	1C2	972-7772	2C10	972-2489
C247	972-8322	C286	972-1113	1C3	011-8599	2C11	972-2489
C248		C287	972-8322	1C4	011-8344	2C12	580-0139
C249	972-2489	C288	972-2563	1C5	972-7772	2C13	580-0139
C251	972-8322	C289	972-2563	1C6	972-7772	2C14	011-8608
C252	103-3628	C291	954-0635	1C7	972-2489	2C15	011-8608
C253	972-8322	C292	972-8322	1C8	972-2489	2C16	011-8610
C254	972-1113	C293		1C9	011-8610	2C17	519-1069
C255	972-8322	C294	972-8322	1C10	972-2489	2C18	519-1069

Cct. N.A.T.O.
Ref. Stock No.

Cct. N.A.T.O.
Ref. Stock No.

Cct. N.A.T.O.
Ref. Stock No.

Cct. N.A.T.O.
Ref. Stock No.

INDUCTORS

5950-99-

L1	972-9565	L35	580-2740	L62	972-9552	L89	972-9560
L2	580-2205	L36	972-9574	L63	Part of L62	L91	972-9554
L3	580-2204	L37	580-2200	L64	580-2740	L92	972-9554
L6	580-2234	L38	932-3319	L65	972-9555	L93	Part of L62
L7	580-2222	L39	580-1946	L66	972-9559	L94	Part of L62
L8	580-2207	L41	580-1947	L67	972-9559	L95	Part of L62
L10	972-8084	L42	580-1948	L68	580-2740	L96	972-9560
L13	580-2218	L43	580-1949	L69	972-9555	L97	972-9560
L14	580-2206	L44	580-1950	L71	972-9553	L98	972-9554
L15	580-2220	L45	972-9576	L72	Part of L71	L99	972-9554
L17	972-9562	L46	580-2740	L73	Part of L71	L100	972-9554
L18	955-7047	L47	580-1946	L74	Part of L71	L101	972-9555
L18	(MA.79A) 580-2217	L48	580-1947	L75	Part of L71	L102	972-9555
L19	580-2216	L49	580-1948	L76	Part of L71	L103	580-2740
L20	580-2205	L51	580-1949	L77	580-2229		
L21	972-9562	L52	580-1950	L78	580-2228		
L23	972-9569	L53	580-2196	L79	580-2332		
L24	580-2234	L54	580-2195	L81	972-9560		
L25	580-2219	L55	580-2231	L82	972-9560		
L28	972-9558	L56	580-2230	L83	972-9554		
L29	580-9020	L57	580-2227	L84	Part of L62		
L31	580-2199	L58	972-9560	L85	Part of L62	L11	580-2481
L32	972-9577	L59	972-9560	L86	Part of L62	L12	580-2481
L33	580-2235	L60	972-9554	L87	580-2226	2L1	580-2481
L34	580-2221	L61	972-9554	L88	972-9560	2L2	580-2481

TRANSFORMERS

5950-99-

T1	580-2509	1T2	580-2194	2T1	580-2192	2T2	580-2194
1T1	580-2192						

Cct. N.A.T.O.
Ref. Stock No.

Cct. N.A.T.O.
Ref. Stock No.

Cct. N.A.T.O.
Ref. Stock No.

Cct. N.A.T.O.
Ref. Stock No.

VALVES

5960-99-

V1 000-0138
V2 000-0138
V3 000-0138
V4 000-2522
V5 000-4014

V6 000-0455
V7 000-0138
V8 000-0453
V9 000-0138
V10 000-3998
V11 000-2209

V12 000-2522
V13 000-0140
V14 000-0138
V15 000-0138
V16 000-0138

V17 000-3998
V18 000-0138
V19 000-0138
V20 000-0138
V21 000-4012

V22 000-0454
V23 000-0138
V24 000-0454
V25 000-0453
V26 000-3998

V27 000-0453
V28 000-0454
V29 000-0138
V30 000-2127
V31 000-4014

V32 000-4014
V33 000-2522
D1
D2
D3 037-2198

D4
D5
D6
D7
D8

SWITCHES

5930-99-

SA 580-5169
SB 580-5170
SB2/3 580-2866
SB4 580-5172

SC 580-5173
SD 051-0554
SE1 955-7051
SE1(MA.79A)580-5175

SE2(MA.79A)580-5174
SE2 955-7050
SF 580-2211
SG 940-3406

SH 051-0554
SJ 580-5171
SK 051-0554

PLUGS

5935-99-

PL1
PL2 054-0101
PL3 054-0151
PL4 054-0151
PL5 054-0151

PL6 054-0101
PL7 054-0151
PL8 054-0101
PL9 054-0151
PL10 054-0151

PL11 054-0151
PL12 054-0151
PL13 054-0151
PL14 054-0152
PL15 056-2503

PL16 054-0152
PL17 054-0152
PL18 054-0151
PL19 054-0152
PL20 054-0151

SOCKETS

5935-99-

SKT1 056-0100
010-8111
SKT2 054-9082
054-9017
054-9018

SKT3 012-2830
012-2833
012-2835
SKT4 012-2827
012-2831
012-2835

SKT5 012-2830
SKT6 012-2827
SKT7 012-2827
SKT8 012-2830
SKT9 012-2830
SKT10 012-2827

SKT11 012-2830
SKT12 012-2830
SKT13 012-2830
SKT15 056-2508
SKT18 012-2830
SKT19 012-2827

Cct. Ref.	N.A.T.O. Stock No.	Cct. Ref.	N.A.T.O. Stock No.	Cct. Ref.	N.A.T.O. Stock No.	Cct. Ref.	N.A.T.O. Stock No.
-----------	--------------------	-----------	--------------------	-----------	--------------------	-----------	--------------------

CRYSTALS

5955-99-

XL1		XL7	580-8435	1XL3		2XL2	
XL2		XL8	580-8436	1XL4		2XL3	
XL3		XL9	580-8437	1XL5		2XL3	
XL4		1XL1		1XL6		2XL4	
XL5		1XL2		2XL1		2XL5	
XL6							

MISCELLANEOUS

5945-99-

RLA 053-0474
 RLB 011-9811

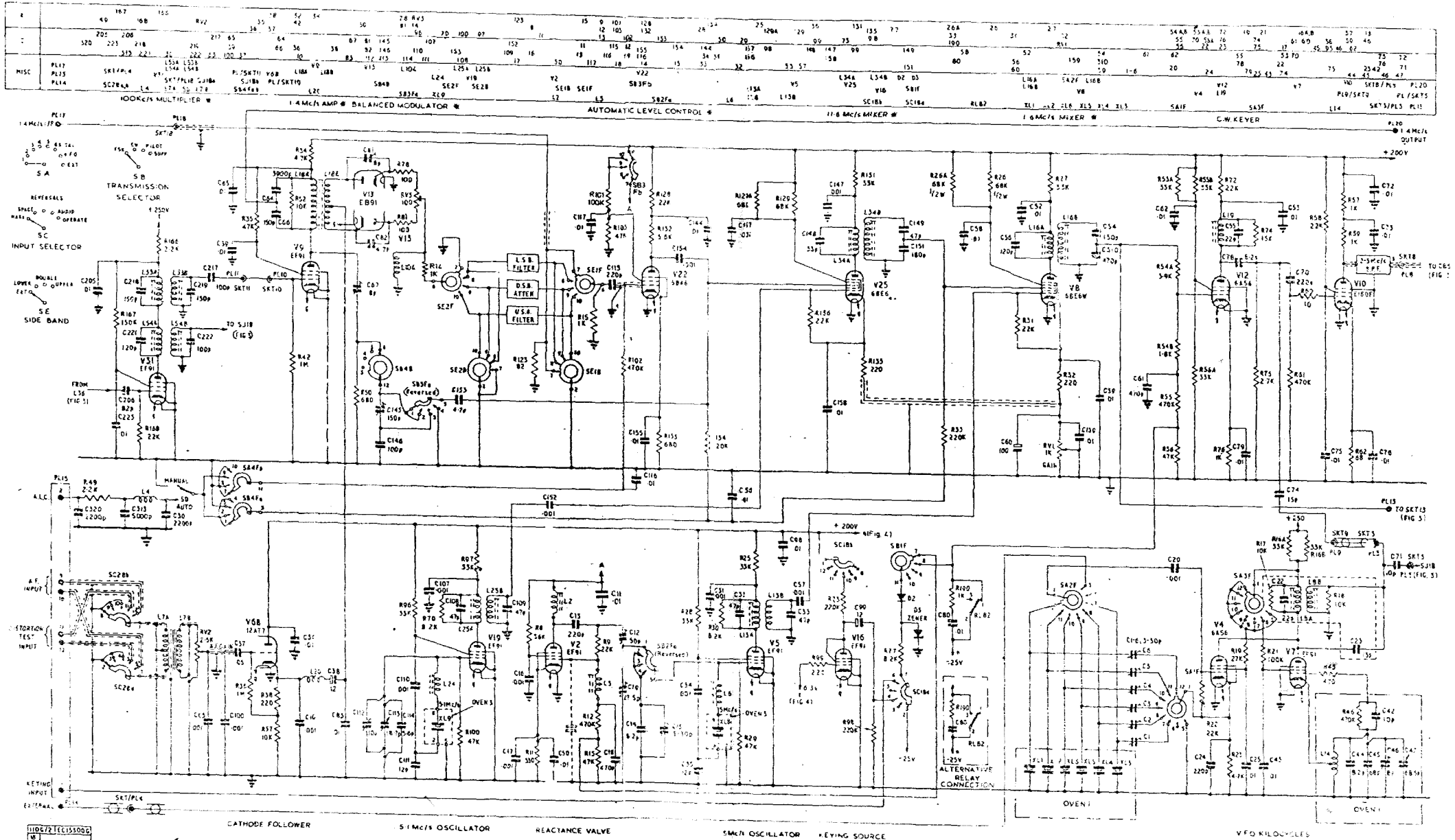

MA.79C CIRCUIT DIAGRAM-1-MODULATION AND I.F. STAGES

3	4	5	6	7	8	9	10	11	12	13	14	15	16	17	18	19	20	21	22	23	24	25	26	27	28	29	30	31	32	33	34	35	36	37	38	39	40	41	42	43	44	45	46	47	48	49	50	51	52	53	54	55	56	57	58	59	60	61	62	63	64	65	66	67	68	69	70	71	72	73	74	75	76	77	78	79	80	81	82	83	84	85	86	87	88	89	90	91	92	93	94	95	96	97	98	99	100	101	102	103	104	105	106	107	108	109	110	111	112	113	114	115	116	117	118	119	120	121	122	123	124	125	126	127	128	129	130	131	132	133	134	135	136	137	138	139	140	141	142	143	144	145	146	147	148	149	150	151	152	153	154	155	156	157	158	159	160	161	162	163	164	165	166	167	168	169	170	171	172	173	174	175	176	177	178	179	180	181	182	183	184	185	186	187	188	189	190	191	192	193	194	195	196	197	198	199	200	201	202	203	204	205	206	207	208	209	210	211	212	213	214	215	216	217	218	219	220	221	222	223	224	225	226	227	228	229	230	231	232	233	234	235	236	237	238	239	240	241	242	243	244	245	246	247	248	249	250	251	252	253	254	255	256	257	258	259	260	261	262	263	264	265	266	267	268	269	270	271	272	273	274	275	276	277	278	279	280	281	282	283	284	285	286	287	288	289	290	291	292	293	294	295	296	297	298	299	300	301	302	303	304	305	306	307	308	309	310	311	312	313	314	315	316	317	318	319	320	321	322	323	324	325	326	327	328	329	330	331	332	333	334	335	336	337	338	339	340	341	342	343	344	345	346	347	348	349	350	351	352	353	354	355	356	357	358	359	360	361	362	363	364	365	366	367	368	369	370	371	372	373	374	375	376	377	378	379	380	381	382	383	384	385	386	387	388	389	390	391	392	393	394	395	396	397	398	399	400	401	402	403	404	405	406	407	408	409	410	411	412	413	414	415	416	417	418	419	420	421	422	423	424	425	426	427	428	429	430	431	432	433	434	435	436	437	438	439	440	441	442	443	444	445	446	447	448	449	450	451	452	453	454	455	456	457	458	459	460	461	462	463	464	465	466	467	468	469	470	471	472	473	474	475	476	477	478	479	480	481	482	483	484	485	486	487	488	489	490	491	492	493	494	495	496	497	498	499	500	501	502	503	504	505	506	507	508	509	510	511	512	513	514	515	516	517	518	519	520	521	522	523	524	525	526	527	528	529	530	531	532	533	534	535	536	537	538	539	540	541	542	543	544	545	546	547	548	549	550	551	552	553	554	555	556	557	558	559	560	561	562	563	564	565	566	567	568	569	570	571	572	573	574	575	576	577	578	579	580	581	582	583	584	585	586	587	588	589	590	591	592	593	594	595	596	597	598	599	600	601	602	603	604	605	606	607	608	609	610	611	612	613	614	615	616	617	618	619	620	621	622	623	624	625	626	627	628	629	630	631	632	633	634	635	636	637	638	639	640	641	642	643	644	645	646	647	648	649	650	651	652	653	654	655	656	657	658	659	660	661	662	663	664	665	666	667	668	669	670	671	672	673	674	675	676	677	678	679	680	681	682	683	684	685	686	687	688	689	690	691	692	693	694	695	696	697	698	699	700	701	702	703	704	705	706	707	708	709	710	711	712	713	714	715	716	717	718	719	720	721	722	723	724	725	726	727	728	729	730	731	732	733	734	735	736	737	738	739	740	741	742	743	744	745	746	747	748	749	750	751	752	753	754	755	756	757	758	759	760	761	762	763	764	765	766	767	768	769	770	771	772	773	774	775	776	777	778	779	780	781	782	783	784	785	786	787	788	789	790	791	792	793	794	795	796	797	798	799	800	801	802	803	804	805	806	807	808	809	810	811	812	813	814	815	816	817	818	819	820	821	822	823	824	825	826	827	828	829	830	831	832	833	834	835	836	837	838	839	840	841	842	843	844	845	846	847	848	849	850	851	852	853	854	855	856	857	858	859	860	861	862	863	864	865	866	867	868	869	870	871	872	873	874	875	876	877	878	879	880	881	882	883	884	885	886	887	888	889	890	891	892	893	894	895	896	897	898	899	900	901	902	903	904	905	906	907	908	909	910	911	912	913	914	915	916	917	918	919	920	921	922	923	924	925	926	927	928	929	930	931	932	933	934	935	936	937	938	939	940	941	942	943	944	945	946	947	948	949	950	951	952	953	954	955	956	957	958	959	960	961	962	963	964	965	966	967	968	969	970	971	972	973	974	975	976	977	978	979	980	981	982	983	984	985	986	987	988	989	990	991	992	993	994	995	996	997	998	999	1000
---	---	---	---	---	---	---	----	----	----	----	----	----	----	----	----	----	----	----	----	----	----	----	----	----	----	----	----	----	----	----	----	----	----	----	----	----	----	----	----	----	----	----	----	----	----	----	----	----	----	----	----	----	----	----	----	----	----	----	----	----	----	----	----	----	----	----	----	----	----	----	----	----	----	----	----	----	----	----	----	----	----	----	----	----	----	----	----	----	----	----	----	----	----	----	----	----	-----	-----	-----	-----	-----	-----	-----	-----	-----	-----	-----	-----	-----	-----	-----	-----	-----	-----	-----	-----	-----	-----	-----	-----	-----	-----	-----	-----	-----	-----	-----	-----	-----	-----	-----	-----	-----	-----	-----	-----	-----	-----	-----	-----	-----	-----	-----	-----	-----	-----	-----	-----	-----	-----	-----	-----	-----	-----	-----	-----	-----	-----	-----	-----	-----	-----	-----	-----	-----	-----	-----	-----	-----	-----	-----	-----	-----	-----	-----	-----	-----	-----	-----	-----	-----	-----	-----	-----	-----	-----	-----	-----	-----	-----	-----	-----	-----	-----	-----	-----	-----	-----	-----	-----	-----	-----	-----	-----	-----	-----	-----	-----	-----	-----	-----	-----	-----	-----	-----	-----	-----	-----	-----	-----	-----	-----	-----	-----	-----	-----	-----	-----	-----	-----	-----	-----	-----	-----	-----	-----	-----	-----	-----	-----	-----	-----	-----	-----	-----	-----	-----	-----	-----	-----	-----	-----	-----	-----	-----	-----	-----	-----	-----	-----	-----	-----	-----	-----	-----	-----	-----	-----	-----	-----	-----	-----	-----	-----	-----	-----	-----	-----	-----	-----	-----	-----	-----	-----	-----	-----	-----	-----	-----	-----	-----	-----	-----	-----	-----	-----	-----	-----	-----	-----	-----	-----	-----	-----	-----	-----	-----	-----	-----	-----	-----	-----	-----	-----	-----	-----	-----	-----	-----	-----	-----	-----	-----	-----	-----	-----	-----	-----	-----	-----	-----	-----	-----	-----	-----	-----	-----	-----	-----	-----	-----	-----	-----	-----	-----	-----	-----	-----	-----	-----	-----	-----	-----	-----	-----	-----	-----	-----	-----	-----	-----	-----	-----	-----	-----	-----	-----	-----	-----	-----	-----	-----	-----	-----	-----	-----	-----	-----	-----	-----	-----	-----	-----	-----	-----	-----	-----	-----	-----	-----	-----	-----	-----	-----	-----	-----	-----	-----	-----	-----	-----	-----	-----	-----	-----	-----	-----	-----	-----	-----	-----	-----	-----	-----	-----	-----	-----	-----	-----	-----	-----	-----	-----	-----	-----	-----	-----	-----	-----	-----	-----	-----	-----	-----	-----	-----	-----	-----	-----	-----	-----	-----	-----	-----	-----	-----	-----	-----	-----	-----	-----	-----	-----	-----	-----	-----	-----	-----	-----	-----	-----	-----	-----	-----	-----	-----	-----	-----	-----	-----	-----	-----	-----	-----	-----	-----	-----	-----	-----	-----	-----	-----	-----	-----	-----	-----	-----	-----	-----	-----	-----	-----	-----	-----	-----	-----	-----	-----	-----	-----	-----	-----	-----	-----	-----	-----	-----	-----	-----	-----	-----	-----	-----	-----	-----	-----	-----	-----	-----	-----	-----	-----	-----	-----	-----	-----	-----	-----	-----	-----	-----	-----	-----	-----	-----	-----	-----	-----	-----	-----	-----	-----	-----	-----	-----	-----	-----	-----	-----	-----	-----	-----	-----	-----	-----	-----	-----	-----	-----	-----	-----	-----	-----	-----	-----	-----	-----	-----	-----	-----	-----	-----	-----	-----	-----	-----	-----	-----	-----	-----	-----	-----	-----	-----	-----	-----	-----	-----	-----	-----	-----	-----	-----	-----	-----	-----	-----	-----	-----	-----	-----	-----	-----	-----	-----	-----	-----	-----	-----	-----	-----	-----	-----	-----	-----	-----	-----	-----	-----	-----	-----	-----	-----	-----	-----	-----	-----	-----	-----	-----	-----	-----	-----	-----	-----	-----	-----	-----	-----	-----	-----	-----	-----	-----	-----	-----	-----	-----	-----	-----	-----	-----	-----	-----	-----	-----	-----	-----	-----	-----	-----	-----	-----	-----	-----	-----	-----	-----	-----	-----	-----	-----	-----	-----	-----	-----	-----	-----	-----	-----	-----	-----	-----	-----	-----	-----	-----	-----	-----	-----	-----	-----	-----	-----	-----	-----	-----	-----	-----	-----	-----	-----	-----	-----	-----	-----	-----	-----	-----	-----	-----	-----	-----	-----	-----	-----	-----	-----	-----	-----	-----	-----	-----	-----	-----	-----	-----	-----	-----	-----	-----	-----	-----	-----	-----	-----	-----	-----	-----	-----	-----	-----	-----	-----	-----	-----	-----	-----	-----	-----	-----	-----	-----	-----	-----	-----	-----	-----	-----	-----	-----	-----	-----	-----	-----	-----	-----	-----	-----	-----	-----	-----	-----	-----	-----	-----	-----	-----	-----	-----	-----	-----	-----	-----	-----	-----	-----	-----	-----	-----	-----	-----	-----	-----	-----	-----	-----	-----	-----	-----	-----	-----	-----	-----	-----	-----	-----	-----	-----	-----	-----	-----	-----	-----	-----	-----	-----	-----	-----	-----	-----	-----	-----	-----	-----	-----	-----	-----	-----	-----	-----	-----	-----	-----	-----	-----	-----	-----	-----	-----	-----	-----	-----	-----	-----	-----	-----	-----	-----	-----	-----	-----	-----	-----	-----	-----	-----	-----	-----	-----	-----	-----	-----	-----	-----	-----	-----	-----	-----	-----	-----	-----	-----	-----	-----	-----	-----	-----	-----	-----	-----	-----	-----	-----	-----	-----	-----	-----	-----	-----	-----	-----	-----	-----	-----	-----	-----	-----	-----	-----	-----	-----	-----	-----	-----	-----	-----	-----	-----	-----	-----	-----	-----	-----	-----	-----	-----	-----	-----	-----	-----	-----	-----	-----	-----	-----	-----	-----	-----	-----	-----	-----	-----	-----	-----	-----	-----	-----	-----	-----	-----	-----	-----	-----	-----	-----	-----	-----	-----	-----	-----	-----	-----	-----	-----	-----	-----	-----	-----	-----	-----	-----	-----	-----	-----	-----	-----	-----	-----	-----	-----	-----	-----	-----	-----	-----	-----	-----	-----	-----	-----	-----	-----	-----	-----	-----	-----	-----	-----	-----	-----	-----	-----	-----	-----	-----	------

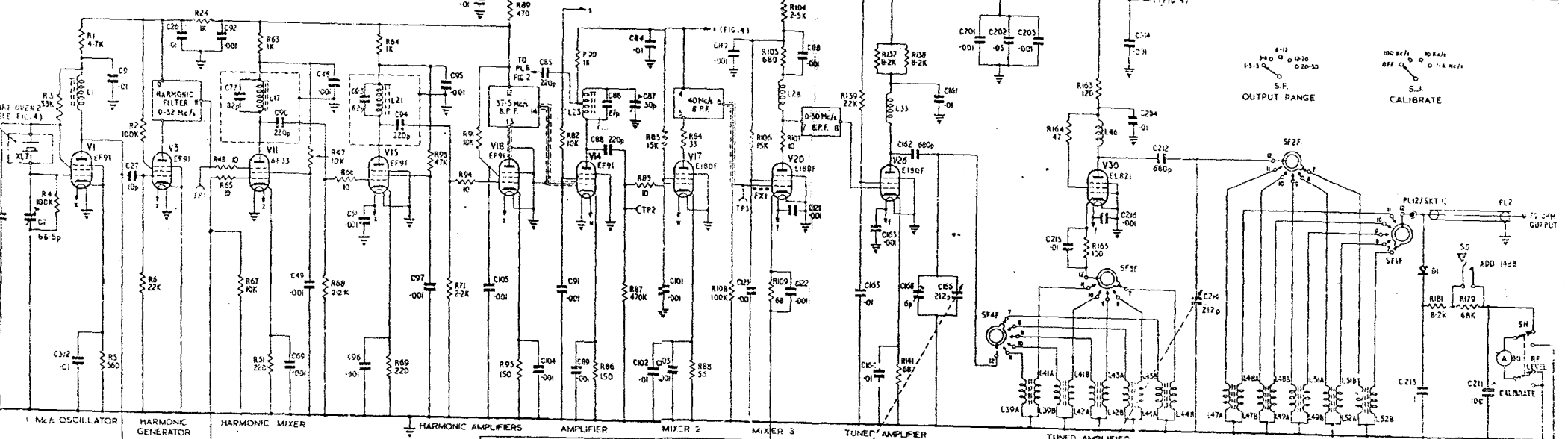

R	44	40	178	196	161	164	182	183	R																		
C	309	40	231	308	232	41	34	35	199	198	196	194	190	197	265	266	269	271	273	268	264	267	263	272	315	316	C
MISC.	PL1	L101	L102	SK	FS2	RLA1	XL8	TI	RLA	DD	ILP1	D5	D7	D4	D6	ILP2	L38	L64, L69	L65, L66	L66, L67	PL15	RLB	PL15	MISC.			

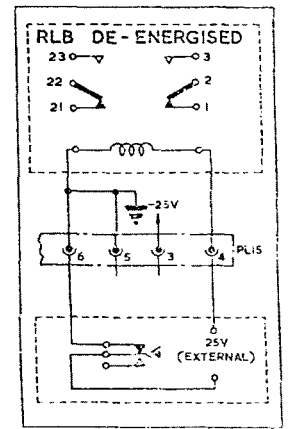
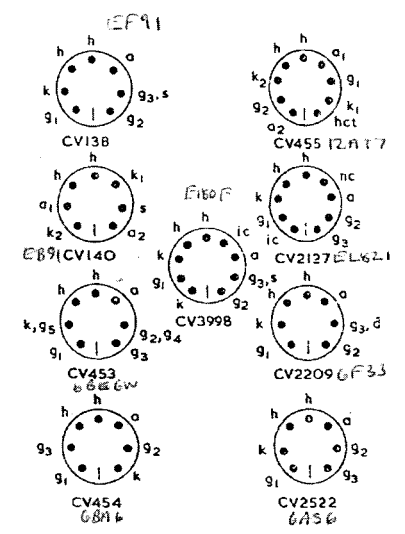
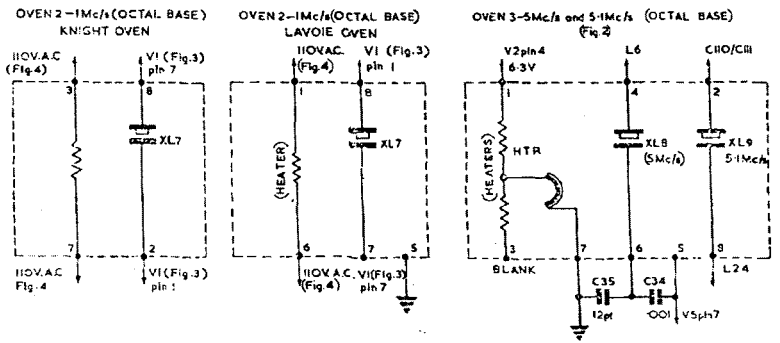
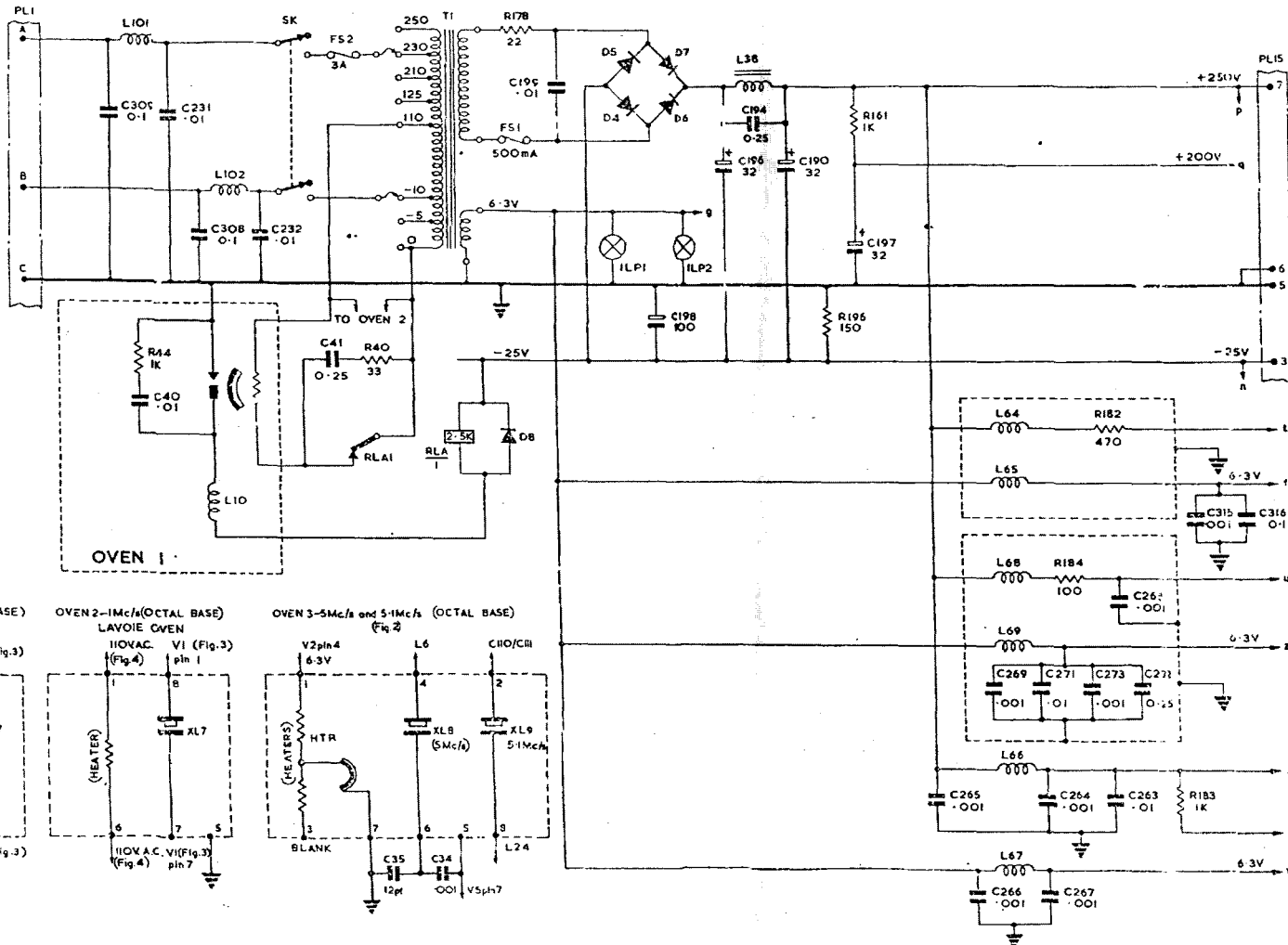

8/110/4 EC16300/G
12/16

MA.79 - ANCILLARY CIRCUITS.

FIG. 4

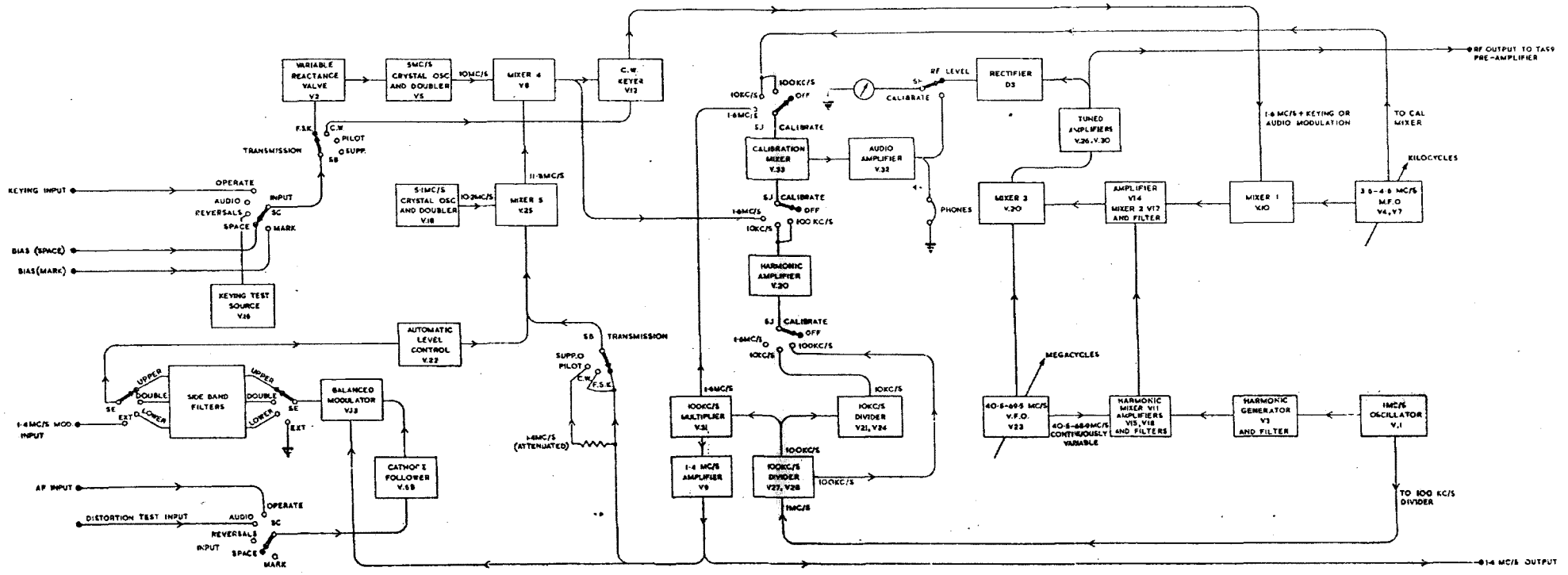

BLOCK DIAGRAM MA79G

FIG. 1

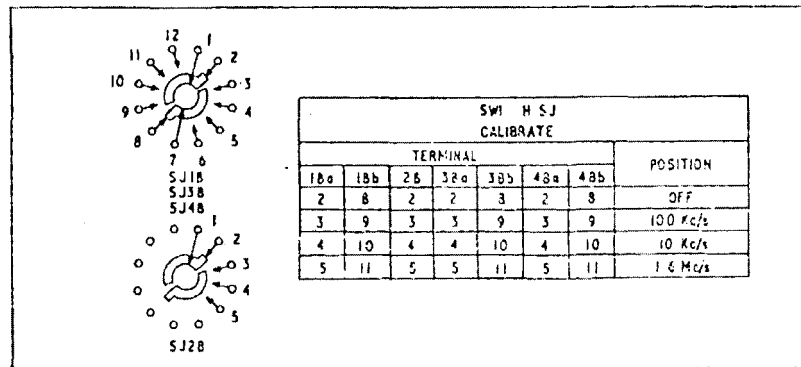
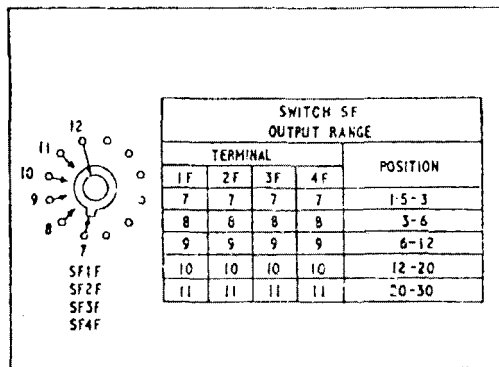
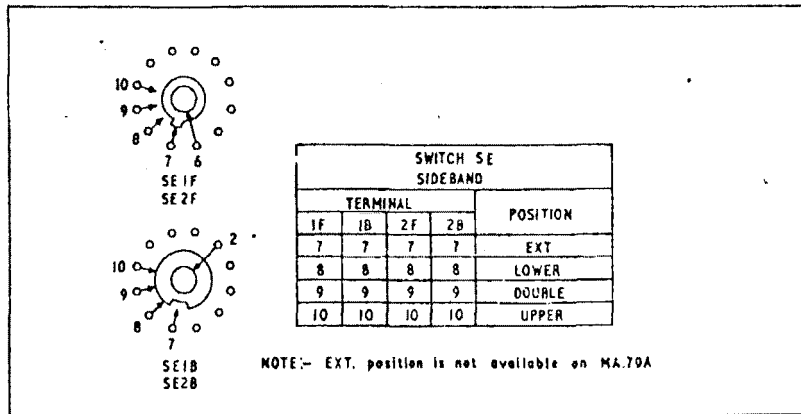
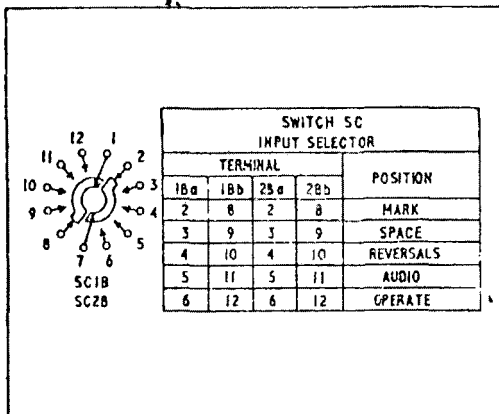
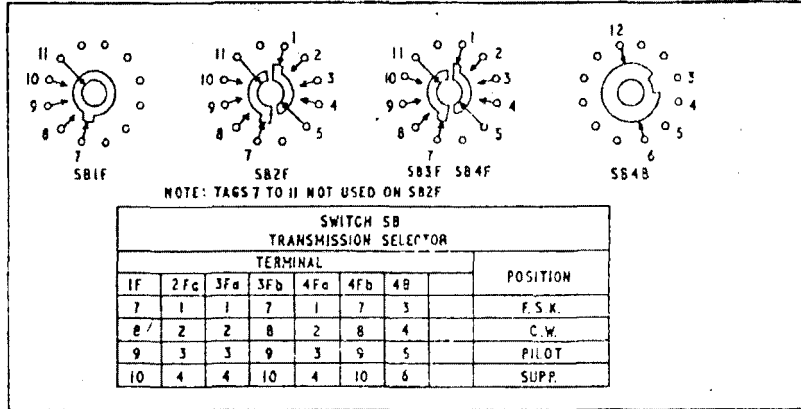
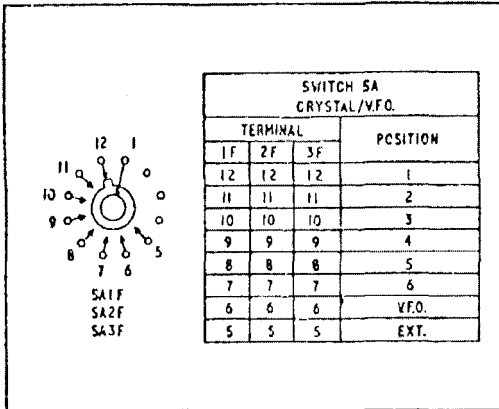

1106/6 EC153004
12

MA.79G SWITCH DETAILS

FIG.6

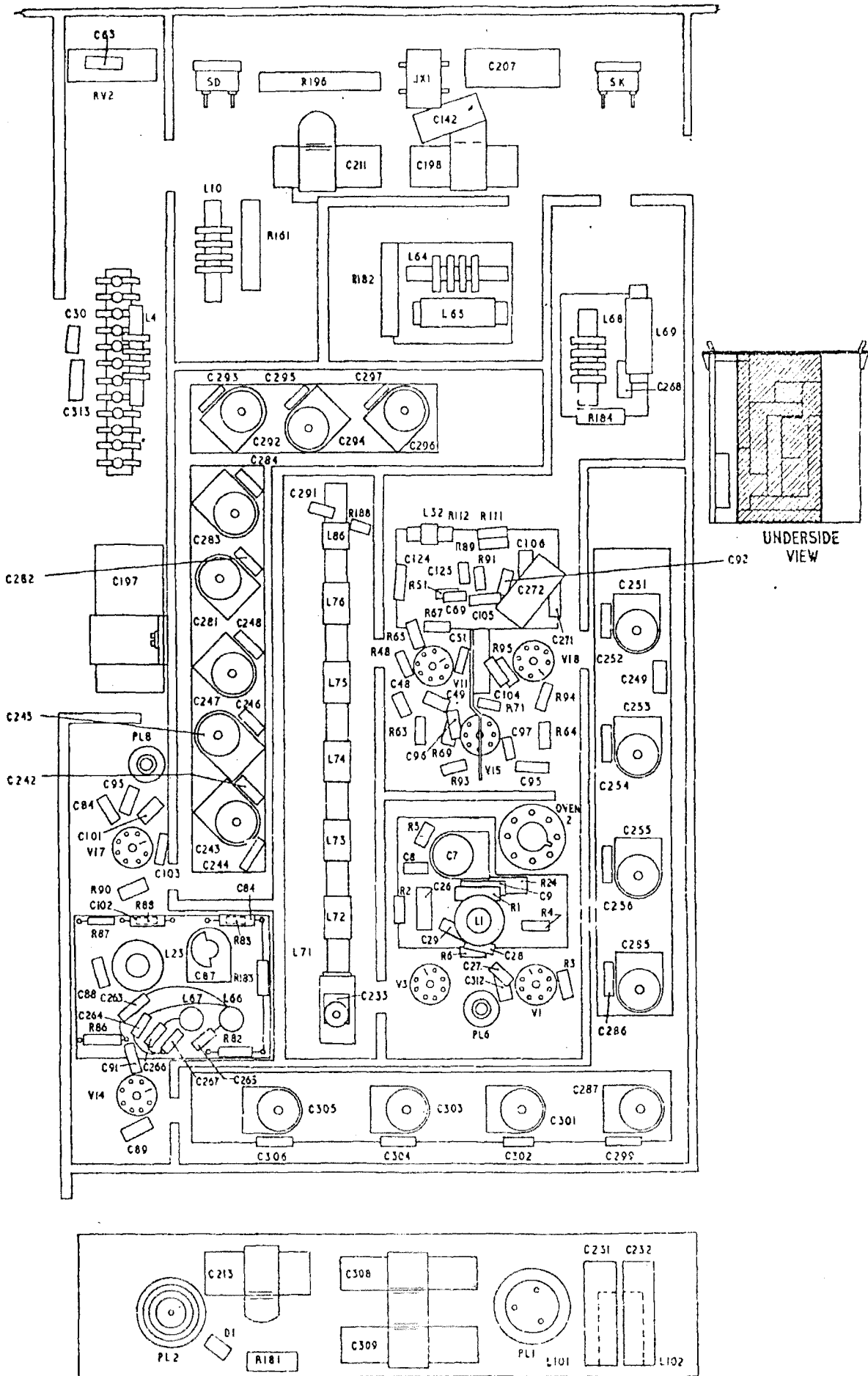

MA.79G MAIN CHASSIS COMPONENT LAYOUT-I

FIG. 8

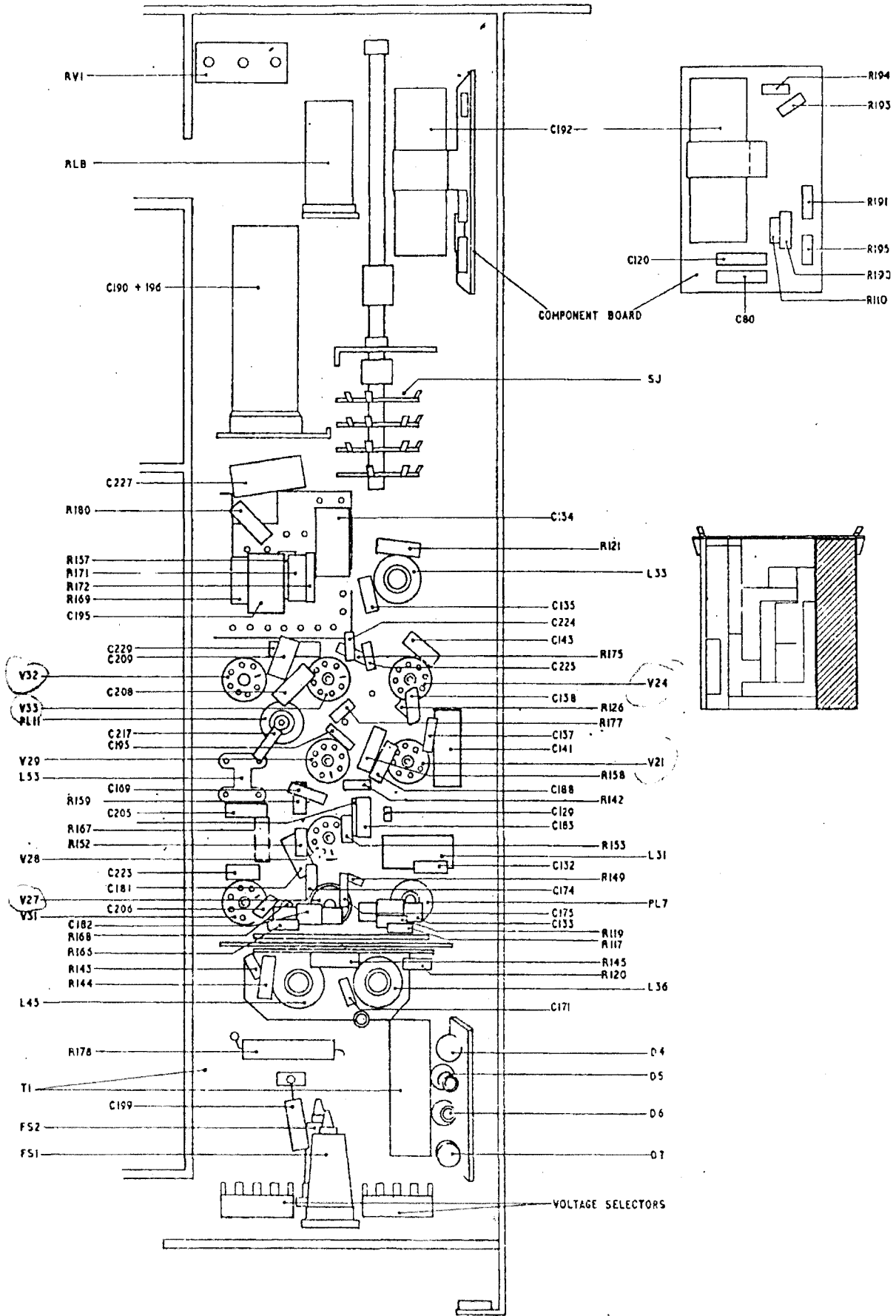

MA79G MAIN CHASSIS COMPONENT LAYOUT-2

FIG.9

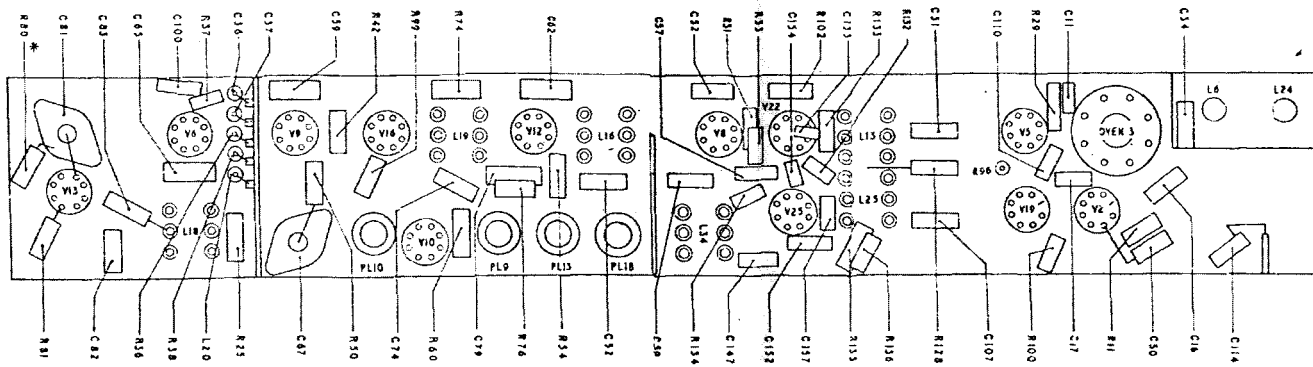

VIEW IN DIRECTION OF ARROW A

FRONT PANEL

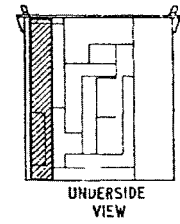

UNDERSIDE VIEW

- NOTES.
1. L.S.B AND U.S.B FILTERS SHOWN WERE FITTED TO EARLY PRODUCTION UNITS: NOW SUPERSEDED BY ENCAPSULATED FILTER
 2. * DENOTES COMPONENT DELETED LATEST PRODUCTION UNITS.

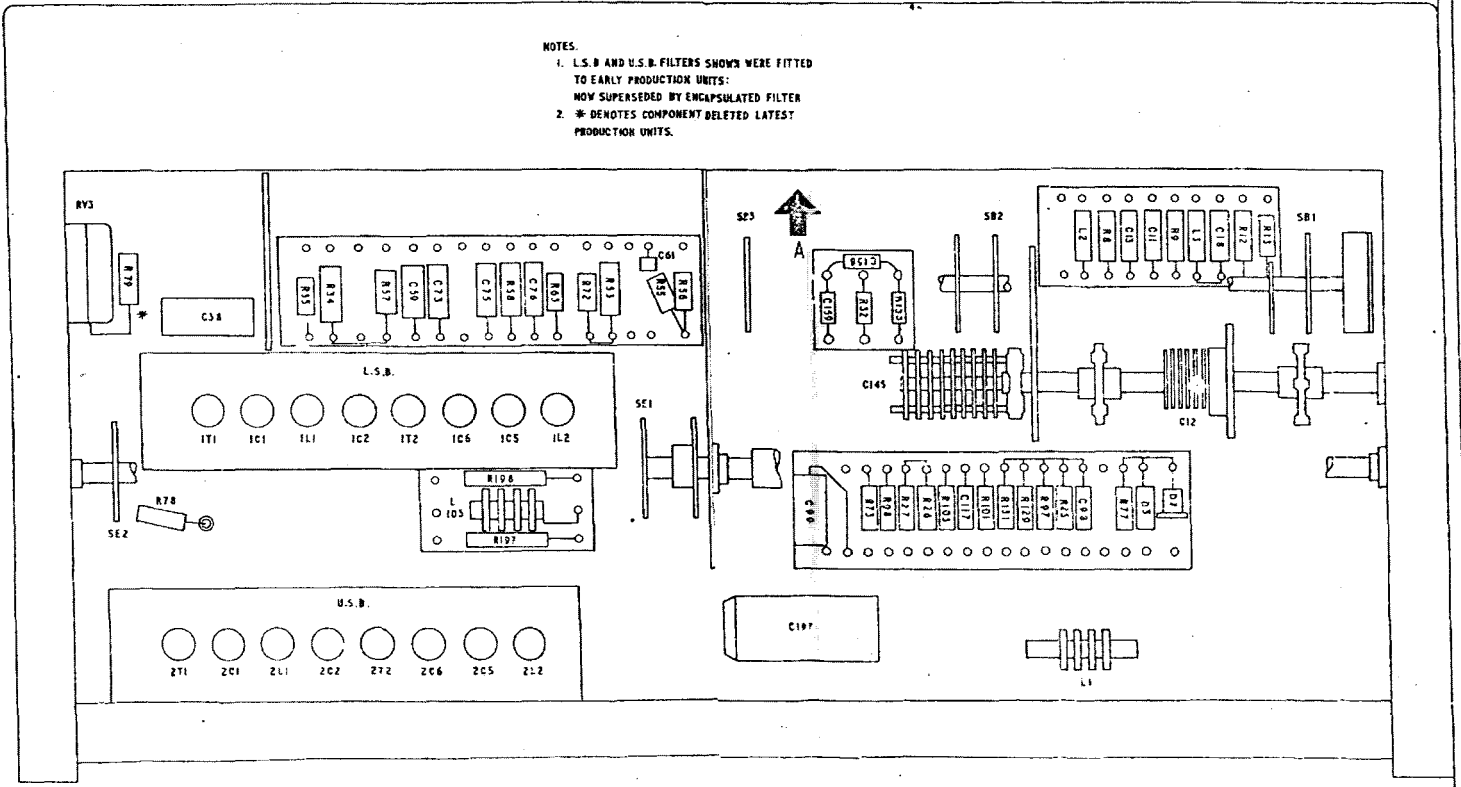

MA.79G MODULATION CHASSIS COMPONENT LAYOUT

FIG.10

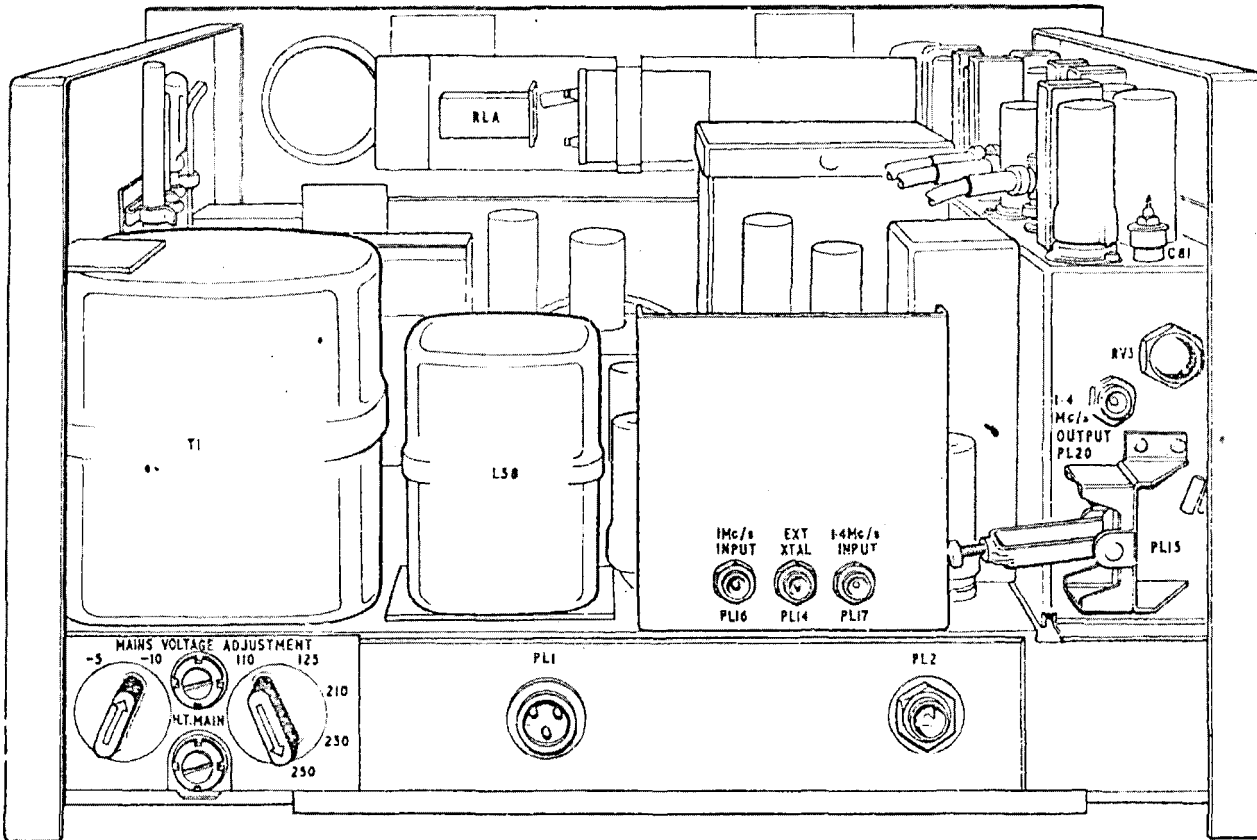

NOTE:- PLS.17 & 20 are not fitted on MA.79A

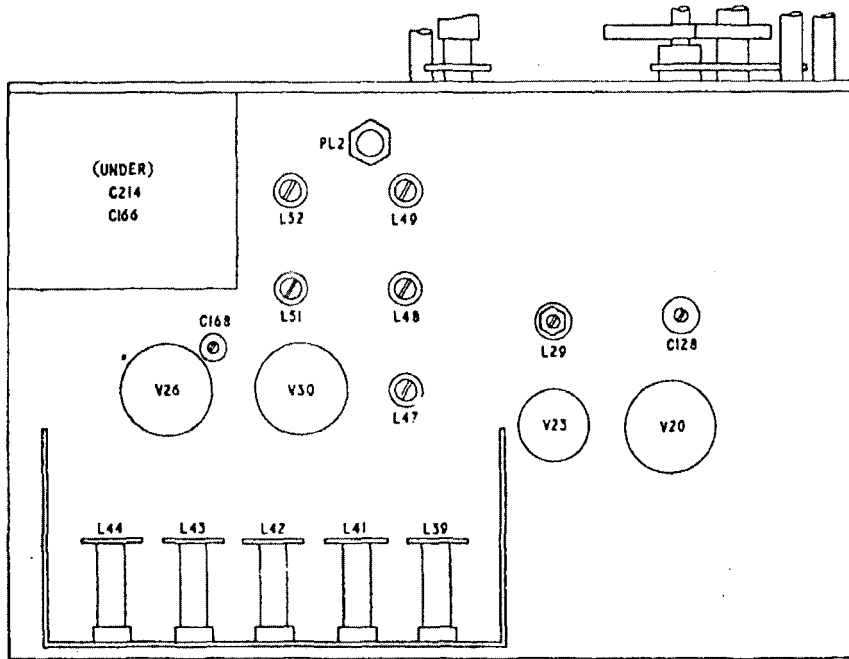

PLAN VIEW

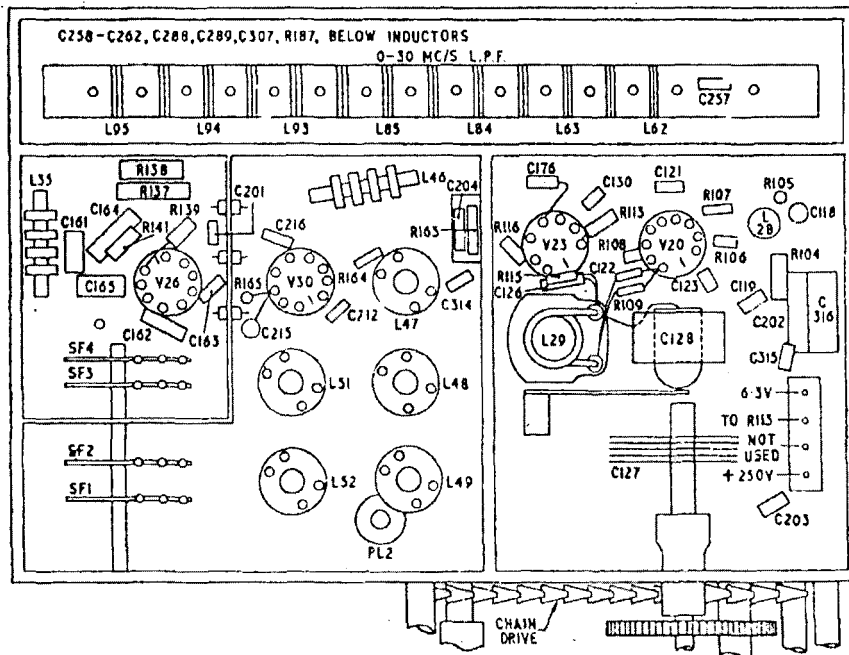

UNDERSIDE

MA.79 Mc/s V.F.O. CHASSIS COMPONENT LAYOUT

FIG.12

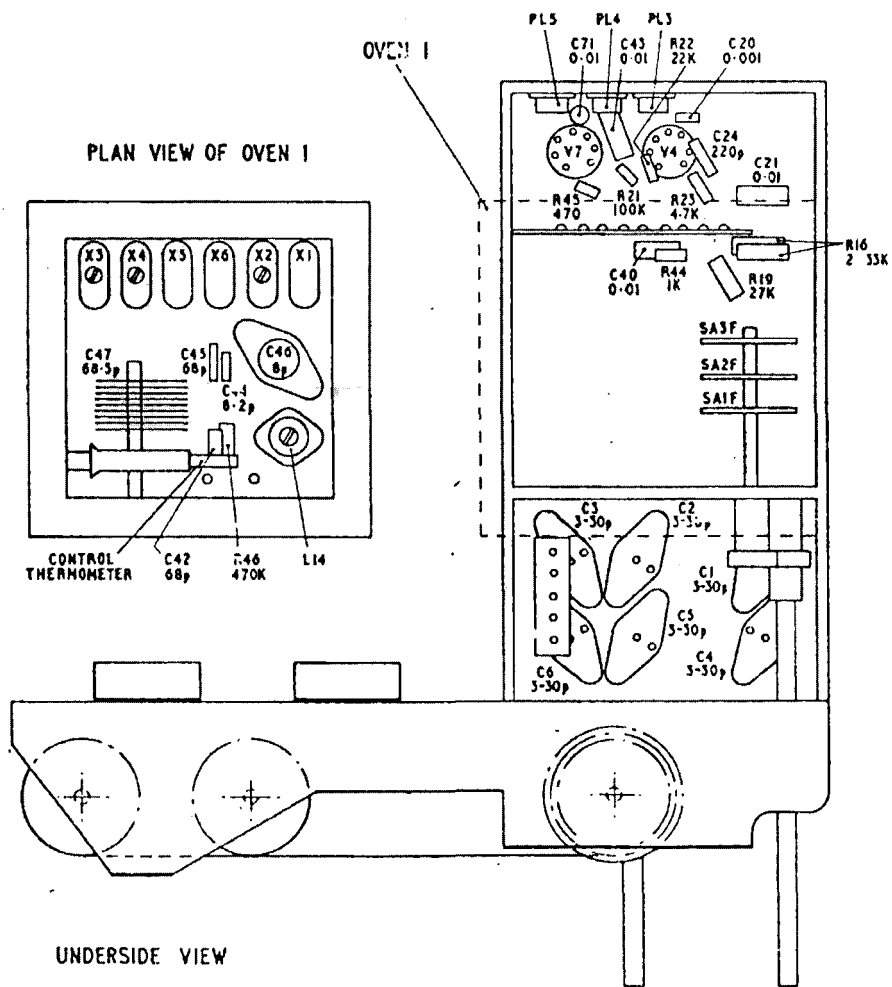

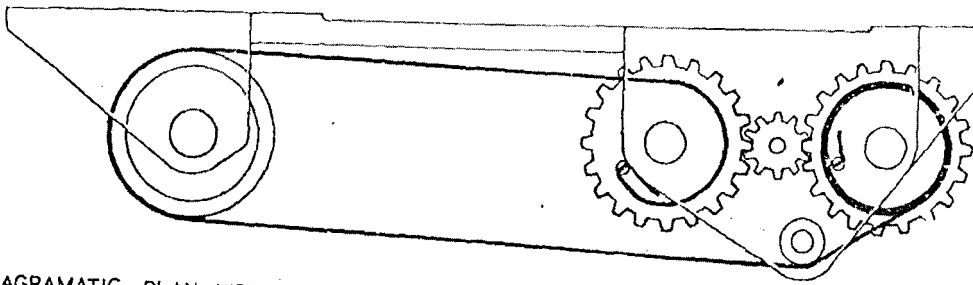

DIAGRAMATIC PLAN VIEW
SHOWING ASSEMBLY OF SCALE FILM

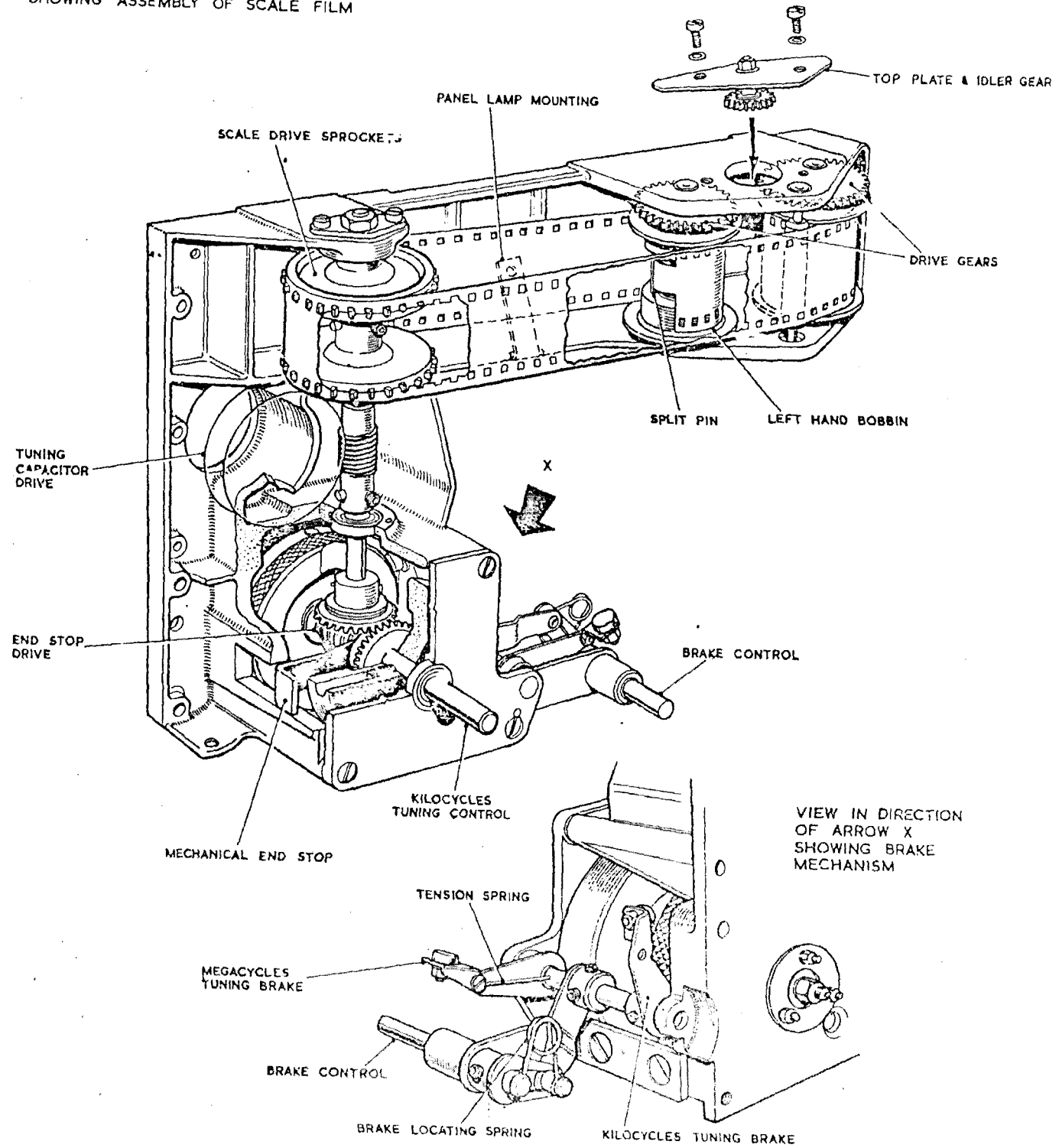

MA.79 KILOCYCLES V.F.O. DRIVE MECHANISM

FIG.14

110/15

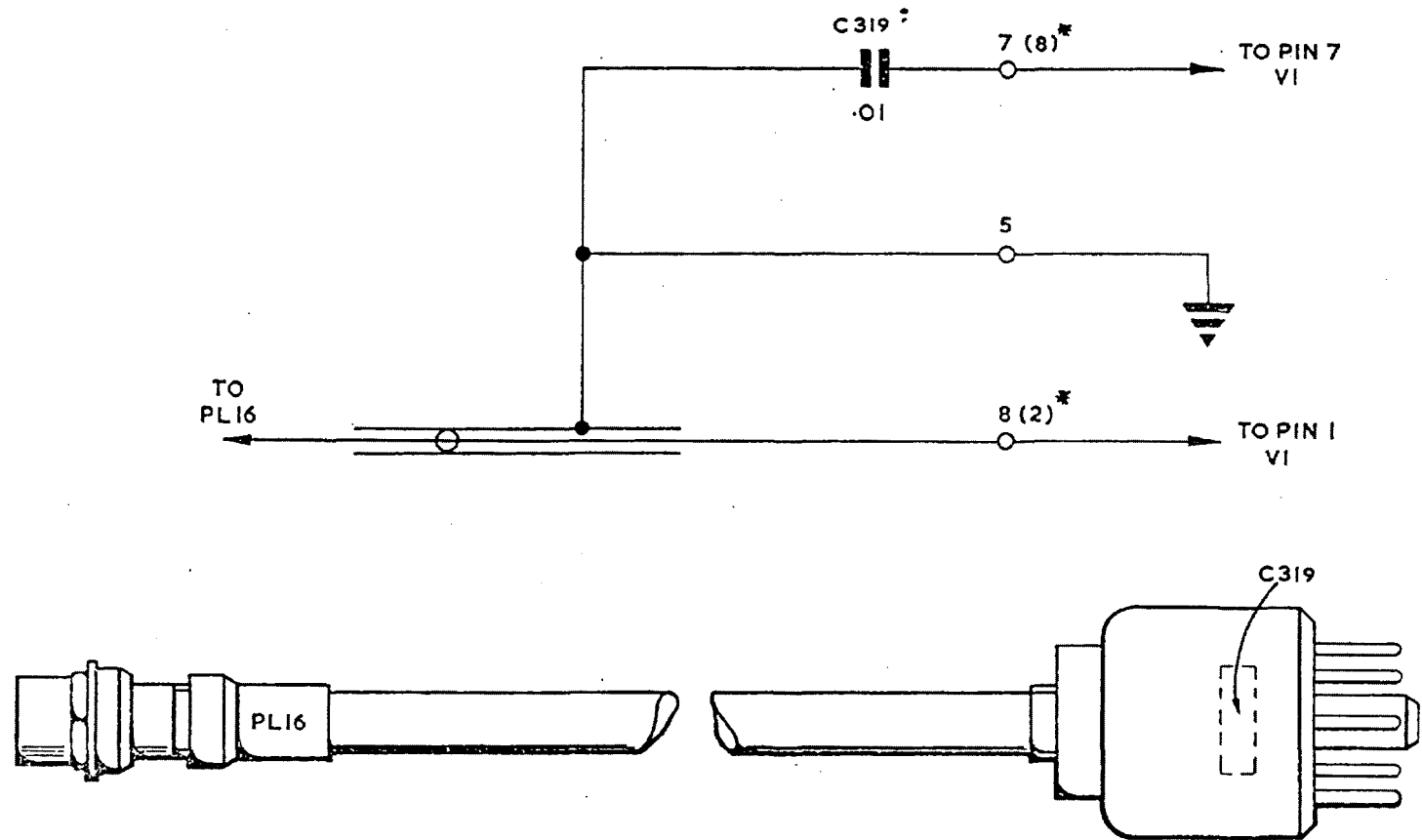

* WHEN THE DRIVE UNIT IS FITTED WITH A KNIGHT OVEN.

Adaptor for externally applied IMc/s to MA.79

Fig. 15