

General Description and Specifications

The SSTR-1 is a small complete short-wave radio transmitter and receiver. The unit is transportable and can be carried in a back pack or suitcase. It will weigh from 20 to 44 pounds, depending on the type of carrier and power supply. A parts kit is normally included and contains various spares.

Transmitter

The transmitter is in a metal box with removable cover, and is 4" wide, 3½" deep, 9½" long. It weighs 4 pounds. The circuit is a single 6L6 tube crystal controlled. The tuning range is in 3 bands -- 3 to 5 mc, 5 to 8 mc, and 8 to 14 mc. The front panel contains all the necessary controls for power input, frequency change, keying, antenna matching, and antenna resonance. There are several different models of this unit, which are described in detail in separate sheets. The maximum power required is 400 v. DC at 75 ma, and 6.3 v. AC or DC at 1 a.

Receiver

The receiver is in a metal box with removable cover. It measures 4" wide, 3" deep, 9½" long. It weighs 5 pounds. The circuit is a 5 tube superheterodyne for telegraph and telephone reception. There are 2 frequency ranges -- 2.7 mc to 6.6 mc, and 6.5 mc to 17 mc. The front panel contains all the necessary controls for frequency change, volume control, power input, and headphones. There are several models of the receiver, which will be described in separate sheets. The power required is 400 v. DC, 30 ma, and 6.3 v. AC or DC at 1.5 a.

Power Supply

The following power supplies are available. They all produce 400 v. 75 ma and 6.3 v. AC or DC at 2.5 a.

- (1) P-1. Dual supply. Input 110/220 v. AC and 6 v. DC. 6" x 3½" x 9½". Weight 10 pounds.
- (2) P-2. Vibrator supply. Input 6 v. DC. 4" x 3½" x 9½". Weight 7 pounds.
- (3) P-4. Input 110/220 v. AC, 25 to 60 cycles. 4" x 3½" x 9½". Weight 11 pounds.
- (4) Hand generator. Revamped Signal Corps GN-35 and GN-44. Weight 25 pounds.

The P-3 is a battery charger with 1 to 2 a. output at 6 v., made of a pile of thermo-couples, and will burn wood, charcoal, gas, or kerosene. Weight 23 pounds. The low voltage side of the Signal Corps hand generators may also be used to charge 6 v. storage batteries.

Various sizes of storage batteries are supplied, the smallest of which is a 25 ampere hour type, weighing 12 pounds. This battery will operate the set for about 1½ hours.

Spare Parts Kit

This kit will contain antenna wire, spare tubes, condensers, fuses, crystals, headphones, and other equipment, depending on the exact use of the set.

TRANSMITTER MODEL SST-1-D
SERIAL NO. 2227 to 2781
AND 2973 to 3417

This transmitter is a crystal controlled oscillator, employing one tube, a 6L6 or 6L6G, with a power output of 8 to 15 watts. A 6F6 or 6V6GT/G will operate at reduced output. It is designated for straight through operation, with the crystal cut for the frequency on which the transmitter is to operate. A multiple type crystal socket on the transmitter will take almost any type of crystal holder. The tank circuit in this transmitter has a tapped rotary coil with a friction roller antenna coupler, which provides an efficient method of antenna coupling over a wide range of frequencies.

Description and Operation of Controls

1. "Power plug and cord". Must be plugged into appropriate power supply socket for operation. The power supply should be off.
2. "Crystal socket". The crystal holder containing the crystal for desired frequency is inserted here with prongs parallel to the length of the transmitter.
3. "Antenna post". Connect antenna of proper length for crystal frequency used, if possible. (See antenna notes).
4. "Ground post". A good ground should be connected to this post, such as a water pipe, radiator pipe, or fire escape. If near the earth, a metal rod can be driven into the ground several feet. If no suitable ground can be obtained, a counterpoise should be connected to the ground post. A counterpoise is a wire about the same length as the antenna, and if possible, placed under the antenna, either on the floor or near the ground.
5. "Frequency change switch". Marked "megacycles". This switch should be placed in the position covering crystal frequency. If crystal frequency is near end of one band try both frequency ranges, that is, if frequency is about 5 mc try both 3 to 5 mc and 5 to 8 mc position for best output. A crystal marked 8125 kc is the same as 8.125 mc.
6. "Receiver power socket". This socket makes power available for the operation of the receiver and also connects the antenna through from the transmitter post.
7. "Dim point" switch. This should be set in extreme right position marked ".1" to begin tuning adjustments.
8. "Antenna resonance" lamp. This is the RF antenna resonance indicator.
9. "Transmit-receive" switch. This switch is turned to "Transmit" position for transmitter operation, to "receive" position for receiver operation.
10. "Antenna coupling". This knob enables proper coupling to antenna.
11. "Tank tuning" control. This will tune the plate tank to proper operating frequency.
12. "Telegraph key". This key completes the cathode circuit for telegraph characters.

13. "Key adjustment" screw. Adjustment of this screw varies the spring tension on the key. The space adjustment screw is located underneath the key knob.
14. "External key jack". This jack is wired in parallel with the "telegraph key" (12). It provides means of plugging in any external keying device.
15. "Antenna loading indicator". This indicates the position of the antenna coupling on the plate tank coil. Set indicator to mid-point of colored line that corresponds with color of numerals the "Frequency change switch" is set on.

With key pressed down, tune "tank tuning" control slowly back and forth and watch "antenna resonance" lamp. Tune for maximum brilliance of lamp. With "tank tuning" control set at this point tune "antenna loading" control for maximum brilliance of lamp. It will be necessary to retune the "tank tuning" control slightly for maximum output. If lamp glows too brightly, turn "dim point" switch to next position. When "antenna resonance" lamp glows with a dull orange color, the "dim point" switch pointer shows approximate RF amperes into antenna. Next try other "antenna coupling" points, each time retuning "tank tuning" and "antenna loading" controls to maximum "antenna resonance" lamp brilliance. Use "antenna coupling" point which shows greatest lamp brilliance and output.

Do not keep key down any longer than is necessary. THIS IS IMPORTANT.
Since when tuning controls are near proper setting some power will be in the antenna, this detection by a DF station may be possible if long dashes are made.

Next test for good keying by sending a short, slow series of dots. If "antenna resonance" lamp does not follow keying, de-tune "tank tuning" slightly on the side of resonance that gives best keying. Also, try a lower "antenna coupling" point.

It is recommended that the new operator practice the tuning of his equipment at his home location before starting out to use it in the field, and that these adjustments be made where another receiver of the communications type is available so that he can listen to his transmitter as he tunes it. This will enable him to see the effect of the various changes he makes by noting how good the transmitter signal sounds in the receiver.

If the transmitter unit does not function properly, try another crystal unit. Also, replace the 6L6 tube with one known to be good. All connections should be checked thoroughly for possible wire breaks.

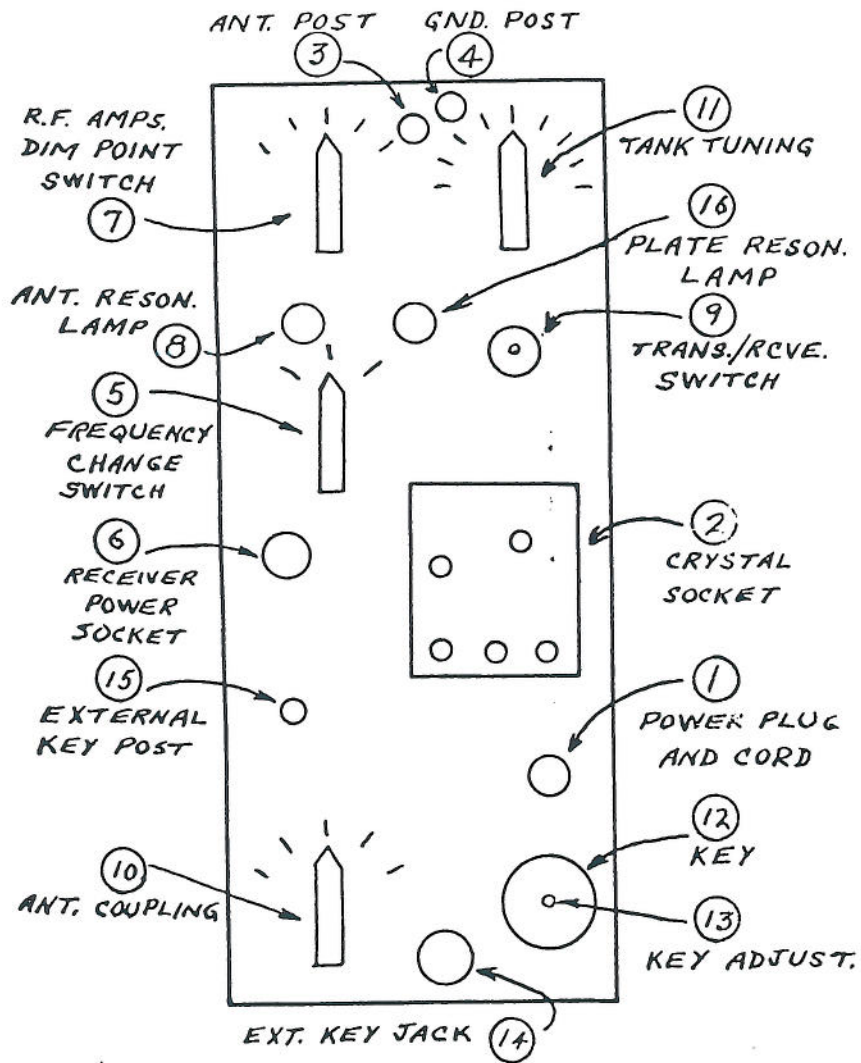

SST-1-C

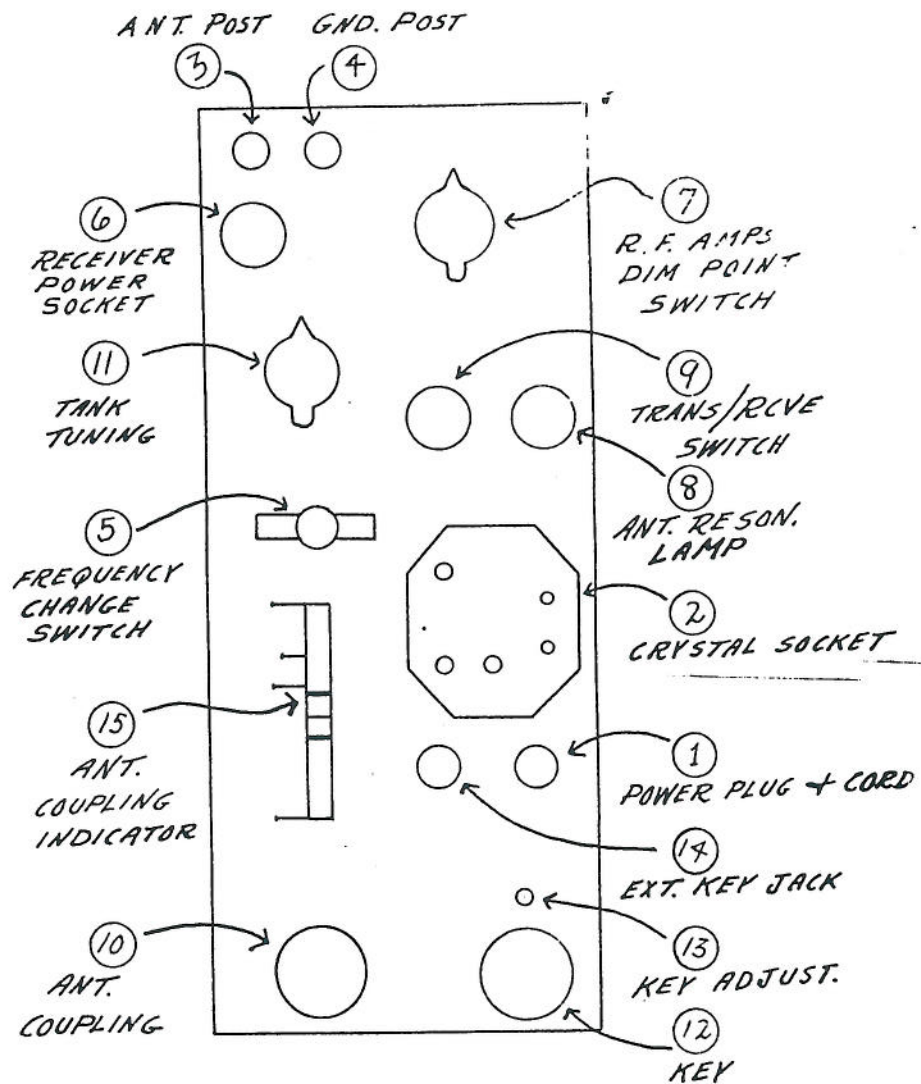

SST-1-D

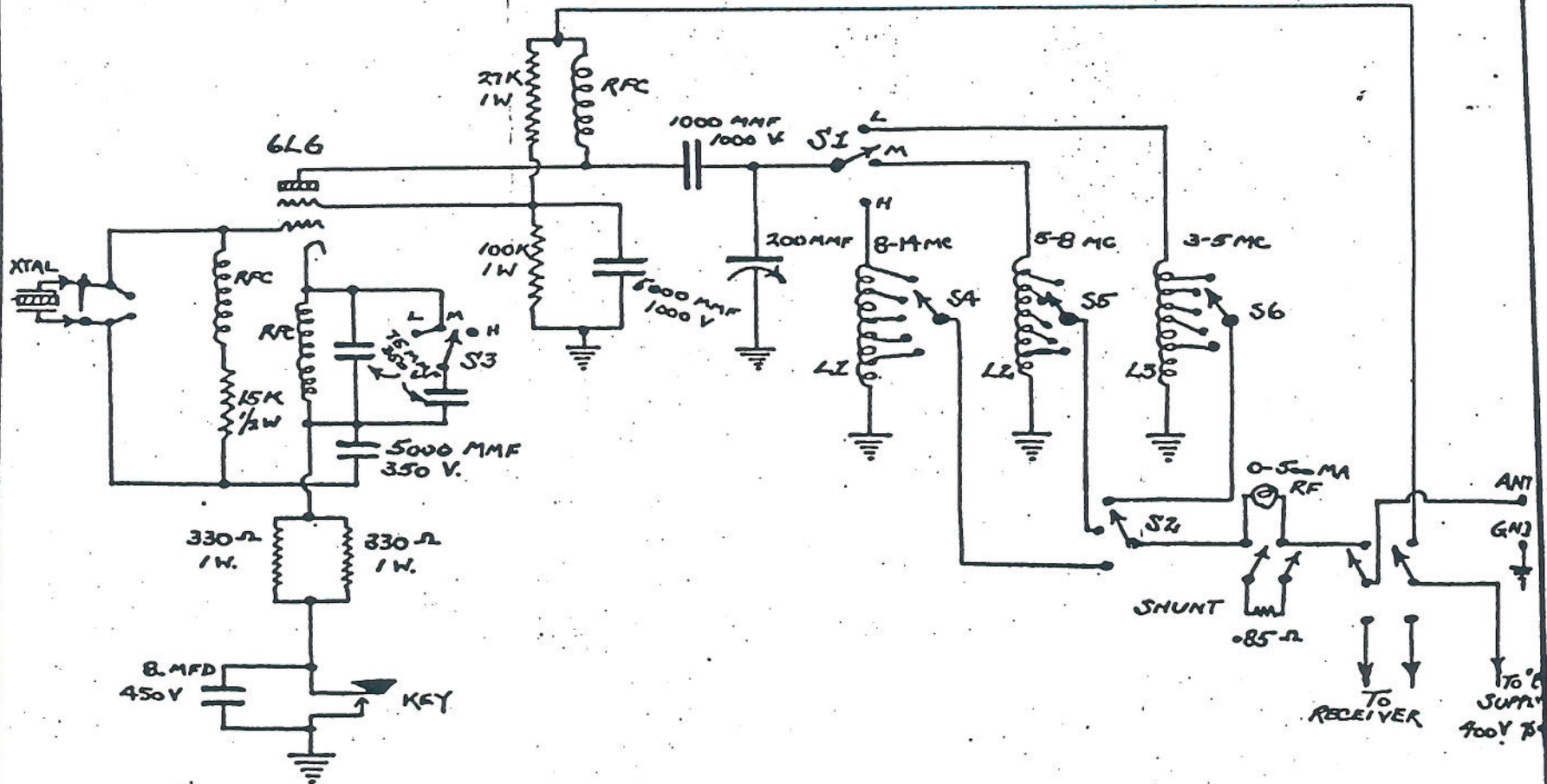

L1 3/4" DIA. 13 T * 20 ENAM 20 T.P.I.
 L2 3/4" DIA. 24 T * 20 ENAM. CLOSE WOUND
 L3 3/4" DIA. 40 T * 24 ENAM. CLOSE WOUND
 S, S2, S3 WAFERS ON SAME SHAFT
 S4, S5, S6 6 POS. ON SAME SHAFT

TYPE 55TR-1
 TRANSMITTER

Calder
 2/4/42

This receiver is a 5 tube superheterodyne, with a 6SG7 tube RF amplifier, a 6SA7 oscillator/converter, a 6SG7 IF amplifier, a 6SQ7 second detector, and a 6SN7 beat frequency oscillator/audio amplifier. The intermediate frequency is 2000 kc.

Description and Operation of Controls

1. "Power plug and cord". Should be plugged into "receiver power socket" on transmitter unit or directly to power supply. The power supply should be turned off.
2. "Phone jack". Headphones should be plugged into this jack.
3. "BFO switch". For reception of telegraph signals this switch should be placed in "ON" position. For reception of broadcast or radio telephone signals, set switch in "OFF" position.
4. "Frequency change switch". It is marked with frequencies in megacycles and should be set to proper frequency range to include desired signals. A frequency of 8125 kc is the same as 8.125 mc.
5. "Volume control". Advance this control in clockwise position to give readable signal in the headphones.
6. "Tuning knob and dial". The tuning knob should be turned slowly while searching for a signal. The dial is calibrated directly in megacycles. The blue band tunes from 2.7 mc to 6 mc. The red band tunes from 6 mc to 16 mc.
7. "Antenna post". This post is not used if the receiver is used with the transmitter unit. If receiver is used separately the antenna is connected here.
8. "Ground post". This post is not used if receiver is used with transmitter unit, but should normally be fastened to a good ground connection if receiver is used alone.

Turn power supply on and allow at least one minute for tubes and power supply to heat up. With controls set as outlined above, background noise and signals should be heard. If receiver is getting power through transmitter unit, be sure that "transmit-receive" switch on transmitter is set to "receive" position. This connects power and antenna to receiver.

When tuning, it is essential that the operator tune very slowly and carefully several points on either side of the dial frequency setting, since the calibration may be off. After the signal is located, it may be necessary to readjust the tuning dial slightly from time to time as the receiver will continue to heat up and change frequency. It is well to know the frequency of standard military and commercial stations and their location on the tuning dial.

If the receiver does not work properly, new tubes may be inserted one at a time until all have been replaced. In most instances glass tubes of the same type number as the metal tubes should work satisfactorily. All connections should be checked thoroughly for possible wire breaks. A further check should be made by plugging the receiver directly into the power supply.

03385 TUBE LAYOUT AND ALIGNMENT LABEL FOR SSR-1-G

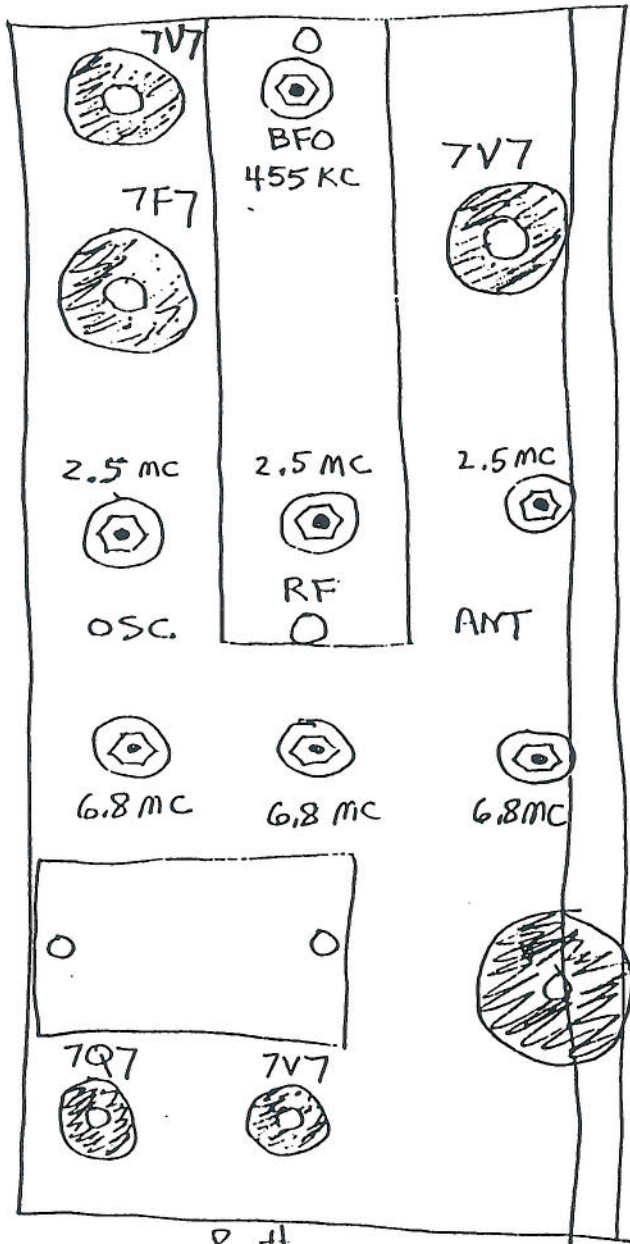

Bottom

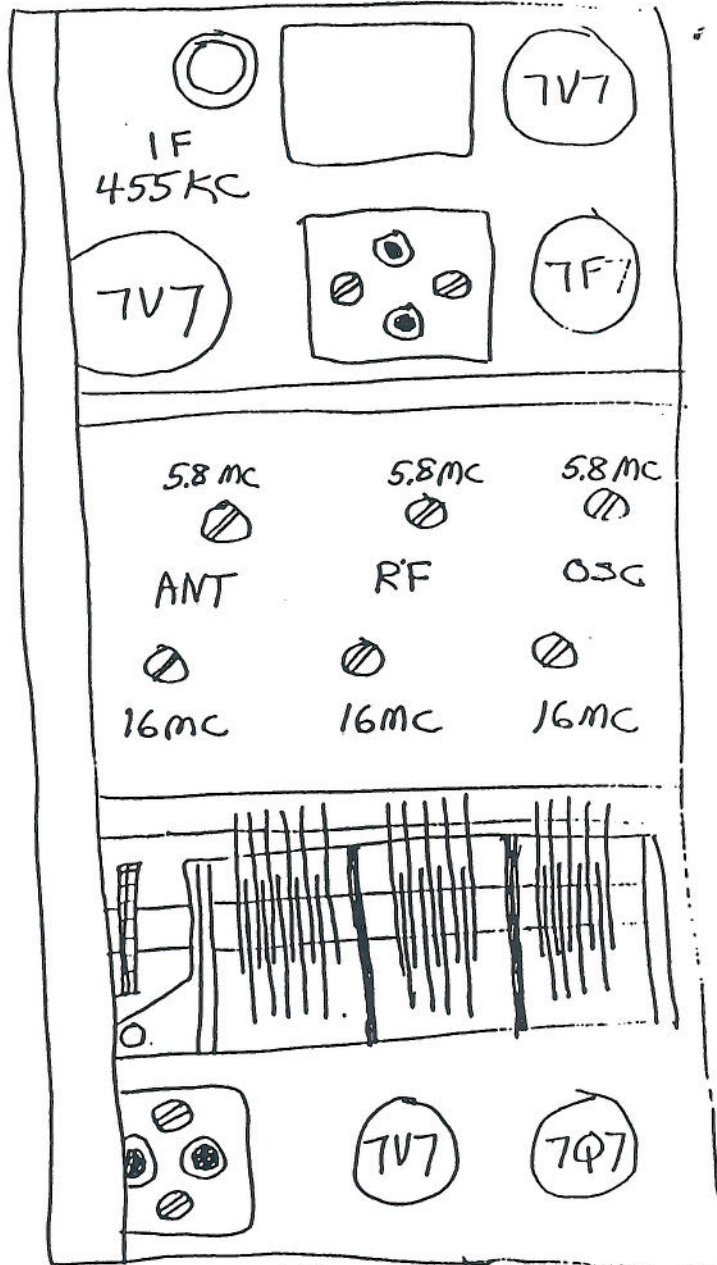

IF 455 KC
TOP

SCHEMATIC WIRING DIAGRAM FOR SSR-1-G

U3332-A

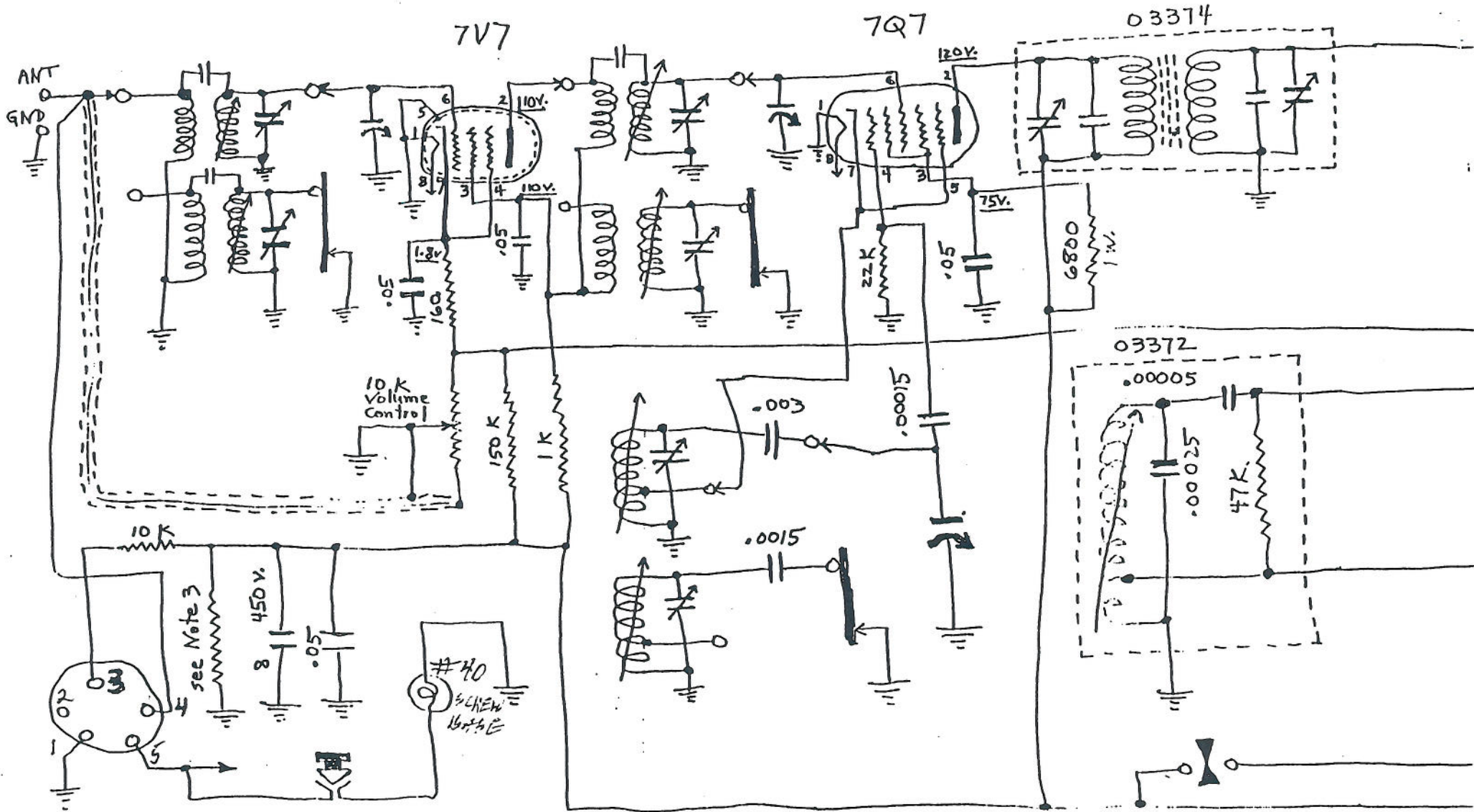

- 1 - GND
- 2 - NC
- 3 - B+
- 4 - ANT
- 5 - FIL

NEON LAMP AS TUNING INDICATOR

COM-014.

A small neon lamp which can be carried in the spare parts kit may be used to tune up the transmitter in lieu of any other means. The neon lamp should be touched against or fastened to the "antenna post". In tuning up the transmitter the lamp will glow brightest when the plate circuit is in resonance with the crystal frequency. It is NOT a good antenna load indicator since the neon lamp will glow at resonance without an antenna attached.

If the neon lamp can be attached to the far end of the antenna wire, then an indication of antenna loading will be possible. Adjust the "antenna coupling" taps until the lamp glows brightest. This method is poor security at night as the neon lamp will glow brightly in the dark.

1. 110/230 V. power cord.
2. 6 V. power cord.
3. Toggle selector switch
4. Rotary " "
5. Charge-operate. "
6. Power socket.
7. 2 A fuse.
8. 20 A fuse.
9. 0-250 V AC meter.

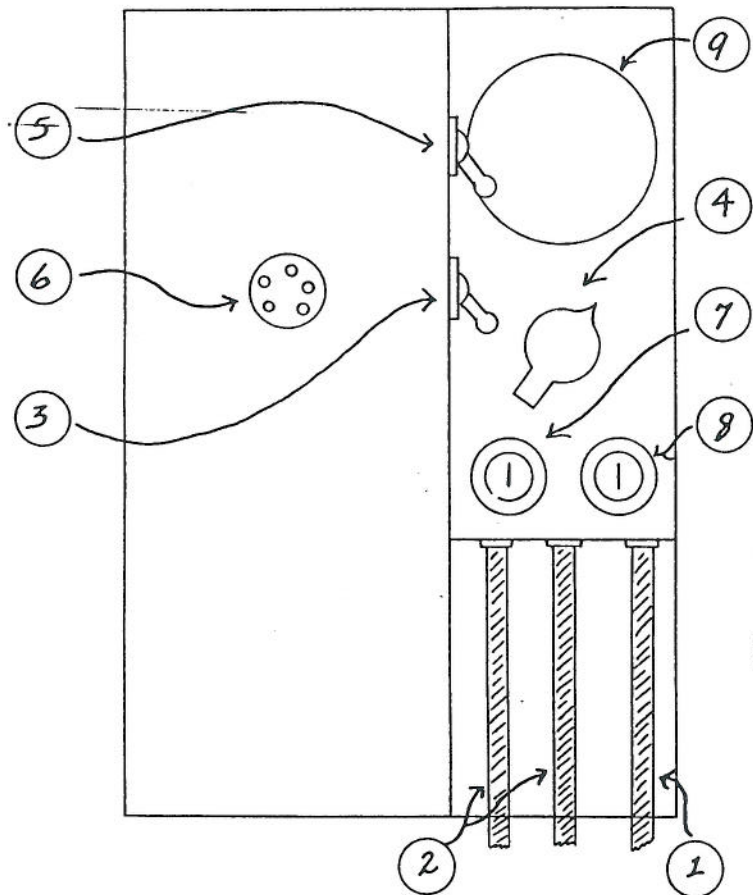

SSP-1

1. 6 v. power cord.
2. Power socket.
3. 15 A. fuse holder.

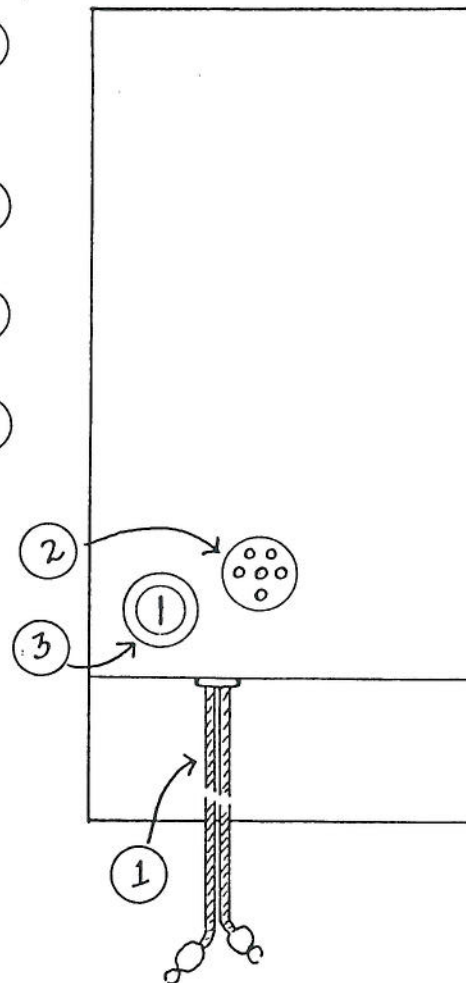

SSP - 2

1. 110/220 v. power cord.
2. Power socket.
3. 110/220 v. switch.
4. ON/OFF switch.
5. 2 A. or 3 A. fuse holder
6. 7Z4 rectifier tube.

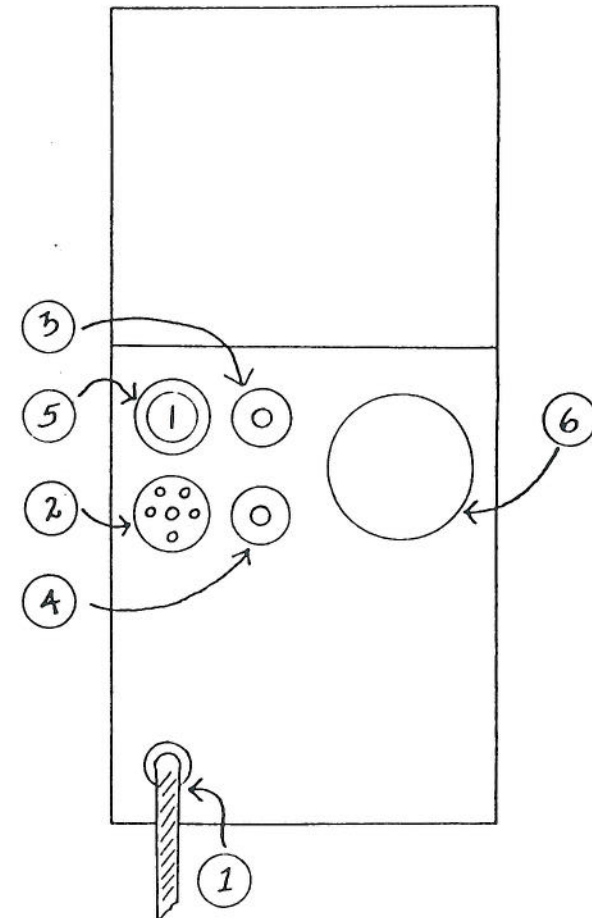

SSP - 4

POWER SUPPLY MODEL SSP-1-D
SERIAL NO. 2350 TO 5349

This power supply will operate from 90 v. AC, 110 v. AC, 150 v. AC, 200 v. AC and 230 v. AC, 40 to 60 cycles, or 6 v. DC. A type 7Z4 rectifier tube is used. For 6 v. DC operation a vibrator is used (usually a Mallory Type 642-C). A selenium rectifier is included for 6 v. storage battery charging from 110/220 v. AC. Both the DC and AC input circuits are fused for protection. Three switches are provided, two for selecting the proper input voltages and one to control battery charging circuit. A 0-250 v. AC meter is connected across the 110/230 v. AC power cord to determine the AC input voltage.

Description and Operation of Controls

1. "110/230 v. power cord". This cord should not be plugged in until either a transmitter or receiver is attached to power supply. This cord has a standard American attachment plug. Adapters are supplied to fit other types of power outlets.
2. "6 v. power cord". These cords have clips for fastening to 6 v. storage battery and should not be attached until either a transmitter or receiver unit is plugged into the power supply outlet socket. Cords are polarized but will operate either way on an independent battery. However, if battery is in a car or other equipment, the black cord (or negative) should be attached to grounded battery terminal.
3. "Toggle selector switch". This switch is to select the proper AC input voltage. It should be placed in the left hand position for 150 v. AC, 200 v. AC or 230 v. AC, and in the right hand position for 90 v. AC, 110 v. AC or 125 v. AC. If the exact line voltage can not be determined by examining light bulbs or other electrical devices, place the switch in the left hand position for 230 v. AC operation. Then place switch to correspond with reading on AC volt meter.
4. "Rotary selector switch". This switch is to select the proper input voltage. There are five positions on this switch. The extreme left hand position is for 6 v. DC operation. The next position is "OFF". The third position is for 125 or 230 v. AC operation. (If line voltage is not known set switch at this position for AC operation). The fourth position is for 110 or 200 v. AC operation. The fifth position is for 90 or 150 v. AC operation. For AC operation the setting of this switch should correspond with the setting of the "Toggle Selector Switch."
5. "Charge - Operate". This switch should be placed in the "Charge" position for charging a 6 v. storage battery, AFTER the proper AC input voltage has been selected. (Disconnect transmitter and receiver while charging battery.) When the power supply is used with AC voltage to furnish power for the receiver and transmitter place this switch in "Charge" position to allow unit to warm up, then place switch in "Operate" position.

6. "Power socket". Plug the transmitter or receiver unit into this 5 prong socket for power. No. 1 prong is the ground connection, No. 3, 400 v. DC, and No. 5, 6.3 v. AC or DC.
7. "Fuse holder". This holder should contain a 2 a. or 3 a. fuse. It is in series with one side of the AC power cord.
8. "Fuse holder". This holder should contain a 15 a. or 20 a. fuse and is in series with the positive side of the DC power cord.

With the controls set for AC operation, plug in cord and allow several minutes for warm-up. The receiver and transmitter unit will operate when the AC input voltage is ten percent lower or five percent higher than the voltage marking the selector switches are set on. If possible, set the voltage selector switches to correspond with the AC input voltage.

If the power supply does not work, the fuses should be checked. Spare fuses are normally carried in the clips mounted on the top cover. Also, the bottom pack cover should be removed and a new vibrator or 7Z4 tube inserted. All connections should be checked thoroughly for possible wire breaks or poor switch contacts.

Unless a very quick change-over from DC to AC operation is needed, the AC power cord should not be plugged in when the unit is run from a storage battery. This will do no damage but may cause vibrator noise to be introduced into the receiver.

FIELD SET ANTENNA DATA

It is strongly recommended that most careful attention be paid to the choice of antennas for use with our field sets at the time the field set user obtains the equipment. It is essential that careful attention be paid that the antennas selected be the most suitable for the type of operation to which the field equipment is to be put.

CLOSE RANGE UP TO 15 MILES: For close range work up to 15 miles, it has been found that operating the field equipment into the antenna stick now provided with the MAB paraset equipped with a loading coil tuned to the general frequency on which the field equipment is to be operated is very satisfactory. It has the added advantage of complete mobility, since it is possible to mount this antenna on the pack board along with the field equipment.

FROM 10 TO 300 MILES: It has been found after extensive field tests that the best possible type of antenna for use over these ranges is a half wave antenna erected from 7 to 15 feet off the ground. This antenna should be either end fed, or if more convenient, fed with a single wire transmission line tapped 13% off center. If the end fed type of antenna is erected, the total length of the wire, including the down lead to the transmitter, should be a half wave length long at the operating frequency, when calculated using the formula $468/F$ mc. In this case, the down lead should be a very small part of the total length of the antenna, namely 5 or 6 feet. In the event that such an installation is inconvenient, it is then recommended that the single wire feeder mentioned above should be employed. The single wire fed type of antenna has the additional advantage that the impedance presented at the end of the feeder more closely matches the output impedance of the field equipment. Maximum radiation from this antenna takes place at right angles to the direction in which the wire points. It is, therefore, important that the antenna be erected in a direction which is at right angles to the direction of the station which is to be worked.

An alternate type of antenna, which shows slightly less efficiency but offers the advantage of low noise level and extreme ease of installation, is a half wave antenna calculated by the formula $300/F$ mc attached directly to the transmitter and laid out directly on the ground. This antenna should be made of wire having a good water resistant insulation, such as vinylite. In this case, the antenna is "end fire" and should be laid so the free end points in the direction of the station to be worked.

These 2 antennas are particularly recommended for use in dense jungle or from valley locations where it is desired to transmit over the top of a high mountain into some adjacent valley.

IMPORTANT: In employing both of the above antennas, to realize the maximum possible gain, it is important that the receiving antenna at the base station be of the same type as the transmitting field antennas, properly oriented, and also it is advantageous that the transmitting antenna at the base station be of the same type as the field receiving antenna. If one antenna is employed in the field, both the transmitting and receiving antennas at the base should be of a similar type. These

next page missing

ANTENNAS

General - Try to get antenna as high and as straight as possible. The antenna may be bent up to a right angle if sufficient length cannot be obtained in a straight line. **DO NOT DOUBLE WIRE BACK ON ITSELF.**

The antenna can be partly vertical and partly horizontal. If the antenna is sloping it will be directional to some degree in the plane of the wire at the lower end. A half wave antenna is directional at right angles to the plane of the wire.

The transmitter should be connected to "GROUND" by either a water pipe or a metal stake driven into the ground. If results are not satisfactory place a wire the same length as the antenna directly underneath the antenna on the ground and connect to the "GROUND" post.

Connect 1/2 wave (Marconi) antenna to "Antenna" post and ground to the "Ground" post. The half wave antenna with a feeder is superior to the 1/4 wave. A half wave antenna connected directly to the "Antenna" will also operate.

ANTENNA INFORMATION

Length for 1/2 wave. For 1/4 wave antenna divide "L" by two.

Operating Freq. mags.	L(ft.)	D(ft.)	L(meters)	D(meters)
3.0 - 3.5	140	48	42.75	14.63
3.5 - 4.0	125	44	38.35	13.53
4.0 - 4.5	110	38	33.55	11.29
4.5 - 5.0	100	35	30.48	10.67
5.0 - 6.0	80	30	24.40	9.15
6 - 7	70	25	21.35	7.65
7 - 9	53	20.5	17.57	6.25
9 - 12	45	15.5	13.72	4.73
12 - 14	36	12.5	10.98	3.81
14 - 15	30	10.5	9.15	3.21

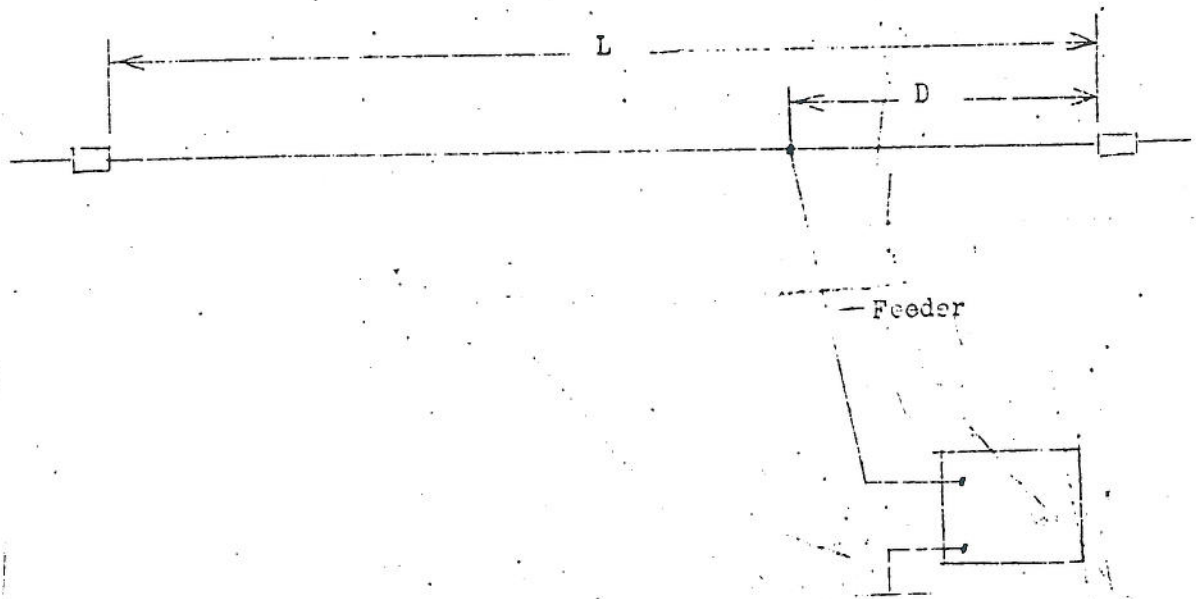

1 EA HEADSET X
1 EA VIBRATOR X

205
CONTENTS

1 EA XTAL HOLDER
3 EA FUSE X

1 ea Receiver, SSR-1-G, Serial Number, 5643 Checked: 3/12/47 RAS
1 ea Transmitter, SST-1-E, Serial Number 5304 Checked: 3/12/47 RAS
1 ea Power Supply, SSP1B Serial Number 3372 Checked: 3/12/47 RAS

Spare Parts

1 ea Tube, 6L6 (G) X
3 ea Lamp, Mazda A4 6.5v 150MA X
100-ft Wire, Antenna #22 Neoprene X
6 ea Insulator, 6" Lucite spreaders X
1 ea Clamp (battery clamp #21A) X
1 ea Knife, TL-29 NO
1 ea Condenser, .01MFD, 500v X
1 ea Band, elastic, large, NO
1 ea Lamp, neon 1/4 watt X
1 ea Instructions X

2 ea Tube, 6SN7 (or 7U7) X
1 ea Tube, 6SB7 (or 707) X
1 ea Tube, 6SC7 (or 7E7) X
1 ea Tube, 6SN7 (or 7Z4) X
1 ea Condenser, Elec. 25 MFD 55v X
1 ea Condenser, Elec. 25MFD 450v X
1 ea Condenser, .01 MFD, 500v X
1 ea Screwdriver, miniature 1/8" X
1 ea Bag, Vinylite, (pistol size) X

1 EA ADAPTOR F X

1 EA ADAPTOR M X

