

80045 PRC 31/570

INSTRUCTION MANUAL

FOR

RADIO SET TAR-224

MANUFACTURED BY



1 JULY 1970

INSTRUCTION MANUAL

FOR

RADIO SET TAR-224

15 September 1971

Manufactured
by

AVCO CORPORATION
ELECTRONICS DIVISION
2630 GLENDALE-MILFORD ROAD
CINCINNATI, OHIO 45241

RADIO SET TAR-224
INSTRUCTION MANUAL
REVISIONS

SEPTEMBER 15, 1971

INSTRUCTION: This package consists of changed Pages and Errata Sheet. Insert the Changed Pages in the manual and destroy superseded pages. Incorporate the changes indicated on the Errata Sheets in the manual by making pen and ink corrections.

ERRATA SHEET

NOTE

Make the following pen and ink changes in Instruction Manual for Radio Set TAR-224 dated 1 July 1970. Retain the information contained on this Errata Sheet by inserting it into the manual. When all indicated changes have been entered in the manual, a note on the front cover "ERRATA, SHEET NO. 1 INFORMATION HAS BEEN POSTED."

Page ii, opposite paragraph 5.3: Change "(1A2)" to "(1A5)."

Page 1-1, paragraph 1.2, subparagraph a: Opposite Power requirement, delete "5.4 amperes" and substitute "5.9 amperes."

Page 1-3, next to last line: Delete "not less than 20 db between" and substitute "not less than 17.5 db between."

Page 3-3, paragraph 3.4.1: In the second line change "1A1S5" to "1A1S3."

Page 3-3, paragraph 3.4.2: In the seventh line of the first subparagraph change "1A3A2R4" to "1A3A2R5."

Page 3-4, upper left (Local oscillator 1A3A4): Change "C51" to "C15."

Page 3-13, second line from top: Change "S1" to "1A4S2" and "R28" to "R18."

Page 3-13, subparagraph e: In first sentence delete "The output of the ALC - - - -" and substitute "The RF output of the ALC - - - -."

Page 3-13, subparagraph e: Add "1A4A7Q8" to the end of the second sentence, making it read " - - - - and the input to the class A amplifier stage 1A4A7Q8."

Page 3-13, paragraph 3.6.2: In heading, delete "(Part of 1A4)" and substitute "(Part of 1A4A8)."

Page 3-13, paragraph 3.6.2, third line of first subparagraph: Delete "R1 and L1" and substitute "circuit assembly 340716."

Page 3-13, paragraph 3.6.2, fifth line of first subparagraph: Delete "C7, C8, L2, L3, R2 and R11" and substitute "circuit assemblies 340999."

Page 3-13, paragraph 3.6.2, second subparagraph: Delete fourth and fifth sentences "Degenerative feedback - - - - and C2. Degenerative feedback - - - - and C3." Substitute "Degenerative feedback from the collector to base of Q3 and Q4 is achieved by networks 340094-1 and 340094-2."

Page 3-13, paragraph 3.6.2, second subparagraph: Add at the end "Resistor R10 provides wideband loading of T3."

Page 4-9, subparagraph 4.4.1.2 a: Add to test equipment list (after VTVM):

“Dummy Load Bird Model 43”

Page 4-9, subparagraph 4.4.1.2 b: Add at end of step (1) and prior to “Note”, the following: “This is a coarse adjustment of forward-power loop-gain. Final adjustment is performed in the Radio Set as outlined in subparagraph 4.4.1.2i.”

Page 4-9, subparagraph 4.4.1.2 b: In the note change “point B” to “pin 5.”

Page 4-9, subparagraph 4.4.1.2 c: Delete title “Reflected Power Detector Adjustment” and substitute “Reflected Power Detector Null Adjustment.”

Page 4-9, subparagraph 4.4.1.2 d: Delete title “Forward Power Detector Adjustment” and substitute “Forward Power Detector Null Adjustment.”

Page 4-12: Add new subparagraph at end of page:

“i. Forward Power Loop Gain Adjustment.

This adjustment can be made only with the RF Sampler Module installed in the Radio Set and a 6.0 MHz crystal installed in the Front Panel. Tune the transmitter of the TAR-224, as described in paragraph 2.5.3, to a frequency of 12 MHz. Use a 50-ohm dummy load as an antenna. With the transmitter keyed, adjust potentiometer 1A4A2R19 for 20 watts output from the transmitter.”

Page 5-1, paragraph 5.3: In paragraph heading, deleted “1A2” from end of heading and substitute “(1A5)”.

Page 5-14, subparagraph 5.8 c: Delete in its entirety step “(1) Line up the mark on the gear - - - -” and substitute “(1) Place wheel in band one position, making sure wheel is detented. Using a marking pen or other non-conductive marking instrument, place a mark on gear tooth and, in line with that mark, place a mark on the edge of the board (figure 5-10)”.

Page 5-18, subparagraph 5.11 a: Add a new step between present steps (6) and (7) as follows: “(7) Remove the three tuner boards.”

Page 5-18, subparagraph 5.11 a: Renumber present steps (7) and (8), respectively, to (8) and (9).

Page 5-18, subparagraph 5.11 a: Add a new step after the newly numbered step (9) as follows: “(10) Unsolder the ground straps from the tuner parent board.”

Page 5-18, subparagraph 5.11 a: Renumber present steps (9), (10), (11) and (12), respectively, to (11), (12), (13) and (14).

Page 5-19, subparagraph 5.11 b: Add a new step between the present steps (9) and (10) as follows: “(10) Resolder the ground strap to the tuner parent board.”

Page 5-19, subparagraph 5.11 b: Renumber present steps (10), (11), (12), (13), and (14), respectively, to (11), (12), (13), (14), and (15).

Page 5-19, subparagraph 5.11 b: Add a new step after the newly numbered step (15) as follows: “(16) Replace the three tuner boards and tuner cover.”

Page 5-19, subparagraph 5.11 b: Renumber present step (15) to step (17).

Page 5-19, subparagraph 5.11 b: Add new step (18) after the newly numbered step (17) as follows: "(18) Check and align bushings on the front panel with tuning capacitor shafts on receiver so that excessive side pressure is not placed on shafts. Tighten bushings and replace receiver on front panel."

Page 5-19, subparagraph 5.11 b: Renumber present step (16) to step (19).

Page 5-20, subparagraph 5.12 a: Between present steps (4) and (5) add a new step as follows: "(5) Disconnect RF connector 1A1A4J6."

Page 5-20, subparagraph 5.12 a: Renumber present steps (5) and (6), respectively, to steps (6) and (7).

Page 5-20, subparagraph 5.12 b: Add new step between present steps (4) and (5) as follows: "(5) Replace RF connector 1A1A4J6."

Page 5-20, subparagraph 5.12 b: Renumber present steps (5), (6), (7), and (8), respectively, to steps (6), (7), (8), and (9).

Page 5-20, subparagraph 5.13 a, step (5): In first sentence delete last word "line" and substitute "lines".

Page 5-22, change call out on right side from "Motor Relay 1A4K2" to "Tune Relay 1A4K3".

Page 5-26, subparagraph 5.13 b: Change step (3) to read: "(3) Connect the key lines, the receiver coax, the coax to 1A4J6, and the forward and reflected ALC coaxes."

Page 5-26, subparagraph 5.16 a: Change step (4) to read: "(4) Unsolder the d-c input wire and the ALC injection coax leads."

Page 5-28, subparagraph 5.16 b: Change step (3) to read: "(3) Resolder the RF input and output wires and the ALC injection coax."

Page 5-29, subparagraph 5.17 b., step (2) (b): Delete the second sentence "The screw that is connected to the rotor tab is a nylon screw and has a solder lug under it."

LIST OF EFFECTIVE PAGES

Date of Issue

Original — 1 July 1970
 Change — 15 Sept. 1971

TOTAL NUMBER OF PAGES IN THIS PUBLICATION IS 133 CONSISTING OF THE FOLLOWING

Page	Issue	Page	Issue
Title	15 Sept. 71	6-1 thru 6-8	1 July 70
A	15 Sept. 71	7-1	1 July 70
i	15 Sept. 71	7-2	15 Sept. 71
ii	1 July 70	7-3 thru 7-6	1 July 70
iii	15 Sept. 71	8-1 thru 8-35	15 Sept. 71
iv	1 July 70		
1-1	1 July 70		
1-2	15 Sept. 71		
1-3 thru 1-4	1 July 70		
2-1	1 July 70		
2-2 thru 2-5	15 Sept. 71		
2-6 thru 2-8	1 July 70		
2-9 thru 2-10	15 Sept. 71		
3-1 thru 3-4	1 July 70		
3-5	15 Sept. 71		
3-6 thru 3-8	1 July 70		
3-9 thru 3-12	15 Sept. 71		
3-13	1 July 70		
3-14	15 Sept. 71		
3-15 thru 3-17	1 July 70		
4-1	1 July 70		
4-2	15 Sept. 71		
4-3	1 July 70		
4-4	15 Sept. 71		
4-5 thru 4-7	1 July 70		
4-8	15 Sept. 71		
4-9	1 July 70		
4-10	15 Sept. 71		
4-11 thru 4-12	1 July 70		
5-1	1 July 70		
5-2 thru 5-6	15 Sept. 71		
5-7 thru 5-10	1 July 70		
5-11 thru 5-12	15 Sept. 71		
5-13 thru 5-14	1 July 70		
5-15 thru 5-16	15 Sept. 71		
5-17 thru 5-20	1 July 70		
5-21	15 Sept. 71		
5-22 thru 5-24	1 July 70		
5-25	15 Sept. 71		
5-26 thru 5-30	1 July 70		
5-31 thru 5-33	15 Sept. 71		

TABLE OF CONTENTS (Cont)

		Page
CHAPTER 3	RADIO SET TAR-224 CIRCUIT DESCRIPTION (Cont)	
3.4.8	Internal Calibration Circuit Detailed Description (1A3A6A1)	3-8
3.5	RT-224 Transmitter Functional Block Diagram Description	3-9
3.6	RT-224 Transmitter Circuit Description	3-9
3.6.1	Low Level Module Detailed Description (1A4A7)	3-9
3.6.2	Driver-Final Amplifier Assembly Detailed Description (Part of 1A4)	3-13
3.6.3	Keyer Module Detailed Description (1A4A5)	3-14
3.6.4	Modulator Module Detailed Description (1A4A5)	3-14
3.6.5	RF Sampler Detailed Description (1A4A2)	3-14
3.6.6	Antenna Matching Network Detailed Description (1A4A8)	3-15
3.6.7	Antenna Tuning Module Detailed Description (1A4A1)	3-15
3.6.8	Motor Control Circuitry Detailed Description	3-15
3.7	Power Supply Circuitry (Part of 1A1)	3-16
3.7.1	Battery Protection Circuit	3-16
3.7.2	Battery Charging Circuit Description (Part of 1A1A3)	3-17
CHAPTER 4	ALIGNMENT AND ADJUSTMENT	
4.1	Scope	4-1
4.2	TAR-224 Radio Set Electrical Alignment.	4-1
4.3	TAR-224 Radio Receiver Electrical Alignment Procedure	4-1
4.3.1	Test Equipment	4-1
4.3.2	Local Oscillator Alignment	4-1
4.3.3	RF Amplifier Alignment	4-3
4.3.4	BFO Alignment	4-5
4.3.5	IF Amplifier Alignment	4-5
4.4	RT-224 Radio Transmitter Electrical Adjustment	4-5
4.4.1	Transmitter Adjustments	4-8
4.4.1.1	Low Level Module Adjustments (1A4A7)	4-8
4.4.1.2	RF Sampler Module Adjustments	4-9
CHAPTER 5	RADIO SET TAR-224 DISASSEMBLY	
5.1	Scope	5-1
5.2	Battery Removal and Replacement	5-1
5.3	Case Removal and Replacement (1A2)	5-1
5.4	RR-224 Receiver Removal and Replacement	5-4
5.5	IF Amplifier Removal and Replacement (1A3A7)	5-6
5.6	BFO and Internal Calibration Module Removal and Replacement (1A3A6)	5-6
5.7	Audio Amplifier and AGC Module Removal and Replacement (1A3A8)	5-9
5.8	Antenna Matching Module (1A3A2), RF Amplifier Module (1A3A3), and Local Oscillator Module Removal and Replacement (1A3A4)	5-9
5.9	Interwiring Board Removal and Replacement (1A3A1)	5-14
5.10	Removal and Replacement of Receiver Tape Readout	5-17
5.11	Receiver Tuning Capacitor Removal and Replacement	5-18
5.12	RT-224 Transmitter Removal and Replacement (1A4)	5-19
5.13	Low Level Module Removal and Replacement (1A4A7)	5-20
5.14	Keyer Module Removal and Replacement (1A4A6)	5-26

TABLE OF CONTENTS (Cont)

		Page
CHAPTER 5	RADIO SET TAR-224 DISASSEMBLY (Cont)	
5.15	RF Sampler Module (1A4A2), Motor Control Module (1A4A3), Motor Control Module (1A4A4), and Modulator Module Removal and Replacement (1A4A5)	5-26
5.16	Antenna Tuning Module Removal and Replacement (1A4A1)	5-26
5.17	Antenna Matching Network Removal and Replacement	5-28
5.18	Parent Board Removal and Replacement (1A4A9)	5-29
5.19	Driver-Final Section Shield Removal and Replacement	5-30
5.20	Battery Protection Circuit Parts Removal and Replacement (1A1A1)	5-30
5.21	VFO Coupler (Part of Crystal Switch Assembly) Removal and Replacement (1A1A2)	5-30
5.22	Relay Mounting Bracket Parts Removal and Replacement (1A1A3)	5-32
5.23	Dessicant Removal and Replacement	5-33
CHAPTER 6	TAR-224 RADIO SET MAINTENANCE	
6.1	Scope	6-1
6.2	Receiver Maintenance	6-1
6.3	IF Amplifier Section	6-1
6.4	BFO and Calibrator Section	6-3
6.5	Audio and AGC Section	6-3
6.6	Transmitter Maintenance	6-5
CHAPTER 7	CS-224 CIRCUIT DESCRIPTION AND MAINTENANCE	
7.1	General	7-1
7.2	Circuit Description	7-1
7.3	Crystal Replacement	7-1
7.4	Oscillator Alignment	7-1
7.5	Maintenance	7-4
7.6	CS-224 Disassembly and Assembly	7-4
CHAPTER 8	PARTS LIST AND LIST OF MANUFACTURERS	
8.1	Parts List	8-1
8.2	List of Manufacturers	8-1

LIST OF ILLUSTRATIONS

Figure	Title	Page
1-1	Radio Set TAR-224	1-2
2-1	Radio Set TAR-224, Section Location	2-2
3-1	RR-224 Block Diagram	3-2
3-2	RR-224 Schematic Diagram	3-4
3-3	TAR-224 Front Panel Schematic Diagram	3-5
3-4	RR-224 Wiring Diagram	3-6
3-5	RT-224 Block Diagram	3-10

LIST OF ILLUSTRATIONS (Cont)

Figure	Title	Page
3-6	RT-224 Schematic Diagram	3-11
3-7	RT-224 Wiring Diagram	3-12
4-1	RF Amplifier and Local Oscillator	4-2
4-2	Antenna Matching Network and Parent Board	4-4
4-3	Calibrator and BFO	4-6
4-4	Circuit Board Assembly	4-7
4-5	Modulator, RF Sampler and Motor Control Boards No. 1 and No. 2	4-10
4-6	RF Sampler Test Equipment Set-up	4-11
5-1	Transceiver TAR-224	5-2
5-2	TAR-224 Exploded View	5-3
5-3	TAR-224 Module Location (bottom view)	5-5
5-4	RR-224 Receiver Assembly	5-7
5-5	RR-224 Module Location (bottom view)	5-8
5-6	RR-224 Module Location (right side view)	5-10
5-7	RR-224 Module Location (bottom side view)	5-11
5-8	RR-224 Module Location (left side view)	5-12
5-9	TAR-224 Module Location (top side view)	5-13
5-10	RR-224 Tuner	5-15
5-11	RR-224 Receiver Assembly, Exploded View	5-16
5-12	TAR-224 Front Panel (bottom view)	5-21
5-13	TAR-224 Module Location (right side view)	5-22
5-14	Transmitter Assembly	5-23
5-15	RT-224 Low Level Module and Keyer Module (shield installed)	5-24
5-16	RT-224 Low Level Module and Keyer Module (shield removed)	5-25
5-17	RT-224 Module Location (bottom side view)	5-27
5-18	Back Panel Assembly	5-31
6-1	IF Amplifier Module	6-2
6-2	AGC Board and Audio Board	6-4
6-3	Antenna Matching Module Location	6-6
7-1	CS-224 Schematic Diagram	7-2
7-2	CS-224 Assembly	7-5

LIST OF TABLES

Table	Title	Page
2-1	TAR-224 Controls and Functions	2-1
4-1	Local Oscillator Adjustment	4-3
4-2	RF Amplifier Adjustment	4-5
6-1	IF Amplifier 1A3A7 DC Voltage	6-1
6-2	Calibrator Board (1A3A6A1) DC Voltages	6-3
6-3	BFO Board (1A3A6A2) DC Voltages	6-3
6-4	Audio Amplifier Board (1A3A8A1) DC Voltages	6-3
6-5	AGC Board (1A3A8A2) DC Voltages	6-3
7-1	CS-224 Transistor Terminal Voltages	7-4
8-1	List of Units in Radio Set TAR-224	8-5
8-2	Front Panel 1A1 (Dwg. No. 340603) and Subassemblies 1A1A1 thru 1A1A3	8-5

LIST OF TABLES (Cont)

Table	Title	Page
8-3	Crystal Oscillator 1A2 (Dwg. No. 340569)	8-9
8-4	Receiver 1A3 (Dwg. No. 340601) and Subassemblies 1A3A1 thru 1A3A8	8-10
8-5	Transmitter 1A4 (Dwg. No. 340602) and Subassemblies 1A4A1 thru 1A4A8	8-23

INTRODUCTION

This instruction manual contains all the information necessary to operate and maintain Radio Set TAR-224. Chapter 1 gives the description and leading particulars of Radio Set TAR-224. Operation instructions are given in Chapter 2. The description and theory of operation are in Chapter 3. Chapter 4 contains alignment and adjustment procedures. Assembly and disassembly instructions are given in Chapter 5. Radio set maintenance instructions are contained in Chapter 6. Chapter 7 describes the crystal selector CS-224. Parts listings and procurement data are contained in Chapter 8.

CHAPTER 1

DESCRIPTION AND LEADING PARTICULARS

1.1 Description of Radio Set TAR-224

Radio Set TAR-224 (figure 1-1) is a miniature, all solid-state transmitter-receiver capable of operating in the 2 MHz to 24 MHz frequency range. The TAR-224 consists of a transmitter (RT-224), receiver (RR-224), and a battery (TYPE-224) all housed in one case. The radio is designed to accommodate external frequency sources such as a crystal selector (CS-224), a frequency synthesizer, or an external crystal (CR-18/U). Provisions are also made for operating from an external power source.

The RT-224 transmitter is in the right hand portion of the front panel, with the crystal selector above and the RR-224 receiver to the left. The battery compartment is directly below the receiver mounted against the side of the case. The battery and crystal selector can be removed from the case without removing the front panel.

The radio set is waterproof when all the compartment covers are in place. A dust cover is supplied to cover the entire front panel.

1.2 Characteristics of Radio Set TAR-224

a. RT-224 Transmitter Characteristics

Type	Transistorized; crystal controlled with provision for VFO excitation; CW, AM, or Medium Speed Key operation.
Frequency range	2 to 24 MHz in two bands (2 to 12 MHz and 12 to 24 MHz)
Power output	20 watts, nominal
AM peak power output	20 watts, nominal
Power requirement	12 vdc, nominal, at 5.4 amperes, maximum
Antenna impedance	40 ohms $\pm 45^\circ$ to 250 ohms $\pm 45^\circ$
Keying	Built-in hand key or external key. External keying at rates up to 300 words per minute.
AM Source	Dynamic microphone
Antenna type	Long wire
Input sources	1. Front panel crystal Type CR-18/U Frequency 2 to 12 MHz

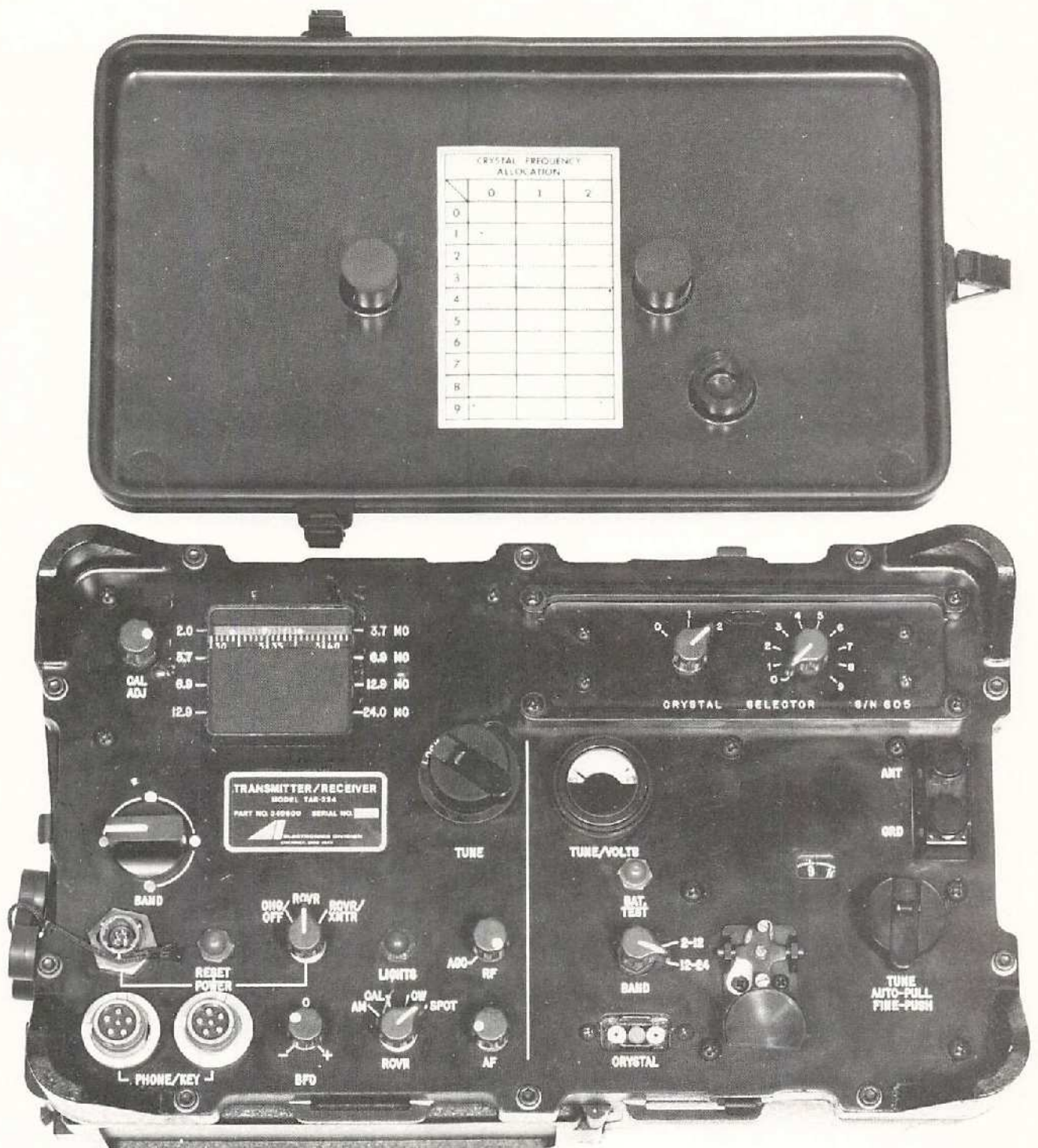

Figure 1-1. Radio Set TAR-224

b. RR-224 Receiver Characteristics (Cont)

Detector	AM: CW/SSB:	Diode envelope detector Product detector
Audio output	Headphones:	Nominal, 1 mw into 500 ohms Maximum, 2 mw into 500 ohms
Calibration	Internal: Transmitter spot:	500 kHz \pm 0.01% Transmitter frequency source
Beat frequency oscillator (BFO) range	\pm 3 kHz minimum	
Size	7-1/4 inches by 12-1/4 inches by 4-3/4 inches overall including the upper protrud- ing corners.	

c. Power Characteristics

Input power	External: +12 vdc Receive: Transmit:	50 ma 4.3 amp, nominal
	Internal: +12 vdc battery Receive: Transmit:	50 ma, nominal 4.3 amp, nominal

d. Physical Characteristics

Weight	TAR-224 - including CS-224 and battery TYPE-224: 13.2 pounds	
--------	--	--

CHAPTER 2

OPERATION

2.1 Scope

This section describes the operating procedures for TAR-224.

2.2 Operation Procedure

To place the TAR-224 in operation proceed as follows:

- a. Select a suitable site. The site preferably should be in an open area with no physical obstructions nearby.
- b. Deploy the antenna.
- c. Choose a power source as detailed in this section, paragraph 2.6.
- d. Perform the tuning and adjustment procedures as detailed in this section, paragraphs 2.4 and/or 2.5.

WARNING

High voltage exists at the antenna terminals while transmitting. To prevent injury to personnel or damage to equipment, do not come in contact with these terminals.

2.3 Front Panel Control Functions

The functions of the external controls, switches, plugs, and meter are given in table 2-1 and the front panel is shown in figure 2-1.

TABLE 2-1. TAR-224 CONTROLS AND FUNCTIONS

Control	Function
POWER connector (1A1J5)	Connector for d-c input power from an external source. Battery can be charged through this power connector.
BATTERY TEST switch (push to operate) (1A1S5)	Test switch to check the d-c power source voltage level as indicated on the TUNE/VOLTS meter.
POWER mode switch (rotary switch) (1A1S2)	Position: CHG/OFF Function: Dc-energizes all power to the radio set but permits the battery to be charged from an external source.

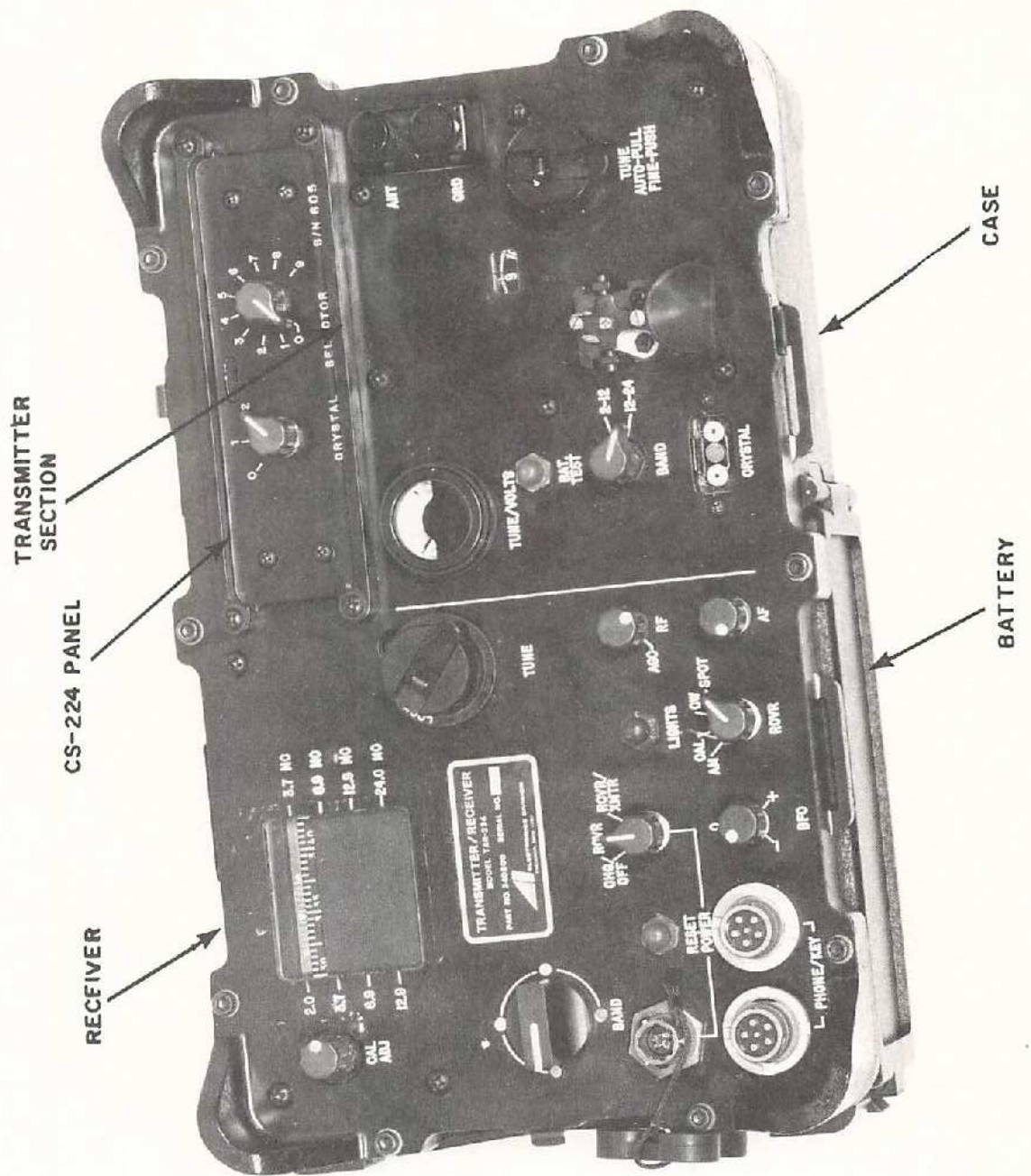

Figure 2-1. Radio Set TAR-224, Section Location

TABLE 2-1. TAR-224 CONTROLS AND FUNCTIONS (Cont)

Control	Function	
POWER mode switch (rotary switch) (1A1S2) (cont)	Position	Function:
	RCVR	Permits continuous operation of the receiver only.
	RCVR/XMTR	Permits operation of the transmitter with the receiver. The receiver is normally on, but the transmitter is permitted to break in.
PHONE/KEY connector (1A1J1)	Connector permits the use of an external keying device, microphone, earphones or handset.	
PHONE/KEY connector (1A1J2)	Connector permits the use of an external keying device, microphone, earphones, or a hand set.	
BFO (potentiometer) (1A1R10)	Varies the frequency of the beat frequency oscillator (BFO) ± 3.0 kHz from the center frequency indicated on dial readout.	
RCVR (rotary switch) (1A1S3)	Position:	Function:
	AM	Sets the receiver for AM reception.
	CAL	Energizes the internal calibrator oscillator with check frequencies every 500 kHz.
	CW	Sets receiver for CW reception.
	SPOT	Energizes the selected transmitter frequency drive source as a calibration signal.
LIGHTS (push to operate switch) (1A1S6)	When depressed, the receiver frequency readout dial and the TUNE/VOLTS meter are illuminated.	
TUNE knob	Tunes the receiver over the selected frequency band.	

TABLE 2-1. TAR-224 CONTROLS AND FUNCTIONS (Cont)

Control	Function										
CAL ADJ (mechanical control)	Adjusts the frequency readout dial reference pointer to a crystal reference.										
RF - AGC (potentiometer and switch) (1A1R5/1A1S7)	In fully counterclockwise position, activates the automatic gain control (AGC); in other positions, adjusts the level of RF gain.										
AF (potentiometer) (1A1R8)	Adjusts audio output power level to the headset.										
BAND switch, receiver mechanical rotary control and switch.	Moves the frequency dial readout mask opening and selects correlated receiver band.										
	<table border="0" style="width: 100%;"> <tr> <td style="width: 50%;">Position Color:</td> <td style="width: 50%;">Band:</td> </tr> <tr> <td>Orange (Band 1)</td> <td>2.0 to 3.7 MHz frequency band</td> </tr> <tr> <td>Blue (Band 2)</td> <td>3.7 to 6.9 MHz frequency band</td> </tr> <tr> <td>Yellow (Band 3)</td> <td>6.9 to 12.9 MHz frequency band</td> </tr> <tr> <td>Green (Band 4)</td> <td>12.9 to 24.0 MHz frequency band</td> </tr> </table>	Position Color:	Band:	Orange (Band 1)	2.0 to 3.7 MHz frequency band	Blue (Band 2)	3.7 to 6.9 MHz frequency band	Yellow (Band 3)	6.9 to 12.9 MHz frequency band	Green (Band 4)	12.9 to 24.0 MHz frequency band
Position Color:	Band:										
Orange (Band 1)	2.0 to 3.7 MHz frequency band										
Blue (Band 2)	3.7 to 6.9 MHz frequency band										
Yellow (Band 3)	6.9 to 12.9 MHz frequency band										
Green (Band 4)	12.9 to 24.0 MHz frequency band										
CRYSTAL (socket) (1A1A2)	Provides connection for an external crystal (Type CR-18/U or equivalent)										
BAND switch, (transmitter) (rotary switch)	<table border="0" style="width: 100%;"> <tr> <td style="width: 50%;">Position:</td> <td style="width: 50%;">Function:</td> </tr> <tr> <td>2-12</td> <td>Permits the transmitter doubler-amplifier to perform as an amplifier in the 2 to 12 MHz band.</td> </tr> <tr> <td>2-24</td> <td>Permits the transmitter doubler-amplifier to operate as a doubler in the 12 to 24 MHz band.</td> </tr> </table>	Position:	Function:	2-12	Permits the transmitter doubler-amplifier to perform as an amplifier in the 2 to 12 MHz band.	2-24	Permits the transmitter doubler-amplifier to operate as a doubler in the 12 to 24 MHz band.				
Position:	Function:										
2-12	Permits the transmitter doubler-amplifier to perform as an amplifier in the 2 to 12 MHz band.										
2-24	Permits the transmitter doubler-amplifier to operate as a doubler in the 12 to 24 MHz band.										
TUNE/VOLTS (meter) (1A1M1)	Normally indicates the transmitter tuning condition; when the POWER TEST switch is depressed the meter indicates d-c level of power source.										

TABLE 2-1. TAR-224 CONTROLS AND FUNCTIONS (Cont)

Control	Function
Hand Key (1A1S4)	Permits the transmitter to be keyed without the use of any external devices.
TUNE/AUTO-PULL/ FINE-PUSH (mechanical control and switch) (1A4A8S2)	Initiates automatic tune cycle when pulled out. Adjusts the fine tuning of the transmitter when the knob is pushed in.
ANT - GRD (terminals) (1A1J8/1A1J9)	Provides electrical connection of the antenna to the radio set.
RESET (1A1S1)	Overrides battery protection circuit. Connects internal battery as power source.

2.4 Receiver Operation

Before energizing the receiver, connect the antenna to the terminals. Connect the antenna wire to the ANT. terminals and the antenna ground wire to the GRD terminal.

a. POWER Mode Switch. If only the receiver is to be operated, set the power switch to the RCVR position. If the transmitter is to be used with the receiver, place the power switch in the RCVR/XMTR position.

b. Bandswitching. Perform the following steps when switching from one band to another.

- (1) Rotate the receiver bandswitch to the band desired. It will be necessary to overshoot the mark slightly to allow the electrical components to reach their detent position.
- (2) After electrical detent is accomplished turn the receiver bandswitch toward the band mark until the mechanical lock takes place.
- (3) Perform receiver calibration in accordance with paragraph 2.4.1.a.

2.4.1 Readout Dial Calibration

The receiver readout may be calibrated with the aid of the internal calibration oscillator or with the transmitter frequency drive source as a reference.

a. Internal Calibration. The following steps are to be used when calibrating the readout dial using the internal calibration oscillator.

- (1) Set the RCVR switch to the CAL position. The POWER switch to RCVR or RCVR/XMTR.
- (2) Set the RF gain potentiometer to AGC; be sure that the switch clicks into the internal detent.

- (3) Adjust the AF gain potentiometer until background noise is heard in the handset.
- (4) Set the BAND control switch to the band position that covers the desired receive frequency.

NOTE

Internal calibration frequencies indicated in orange occur every 500 kHz.

- (5) Tune the receiver in the vicinity of the calibration frequency until the zero beat is obtained. Do not move the receiver tuning knob after acquiring the zero beat.
- (6) Adjust the CAL ADJ control until the triangle-shaped center point on the vernier dial coincides with the orange calibration indication point on the dial.

b. Transmitter Frequency Source Calibration. The following steps are to be used when calibrating the readout dial using the transmitter frequency drive source.

- (1) Set the RCVR switch to the SPOT position.
- (2) Set the POWER switch to the RCVR position.
- (3) Set the transmitter frequency source to the desired frequency.
- (4) Set the RF gain potentiometer to AGC position; be sure the control clicks into the internal detent.
- (5) Adjust the AF gain potentiometer until background noise is heard in the handset.
- (6) Set the receiver BAND control switch to the band position that covers the desired receive-frequency.
- (7) Tune the receiver to approximately the transmitter source frequency and then tune carefully until the zero beat is obtained. Do not move the receiver TUNE control after acquiring the zero beat.
- (8) Adjust the CAL ADJ control, if necessary, until the triangle-shaped center point on the vernier dial coincides with the transmitter source frequency.

2.4.2 Amplitude Modulation Reception

The following procedure should be used to receive an amplitude modulated signal.

- a. Turn on the receiver as detailed in paragraph 2.4.
- b. Set the BAND select control to the band position that covers the desired receive-frequency.
- c. Be sure that the frequency readout is calibrated as detailed in paragraph 2.4.1.
- d. Set the RCVR switch to the AM position.
- e. Set the RF gain potentiometer to AGC.
- f. Tuning for AM and SSB Reception.

- (1) AM Reception. Tune the receiver until the desired signal is obtained. Adjust the RF and AF gain potentiometer for the desired audio output level.
- (2) SSB Reception. Tune the receiver for most intelligible signal. Place the receiver function switch in CW position and adjust BFO for best signal. Adjust the RF and AF gain potentiometer for the desired audio output level.

2.4.3. Continuous Wave Reception

The following procedure should be used to receive a continuous wave signal.

- a. Turn on the receiver as detailed in paragraph 2.4.
- b. Be sure the frequency readout is calibrated as detailed in paragraph 2.4.1.
- c. Set the RCVR switch to the CW position.
- d. Set the RF gain potentiometer to the fully clockwise position.
- e. Set the BAND select control to the band position that covers the desired receive frequency.
- f. Set the BFO control to 0.
- g. Tune the receiver until the desired signal is obtained. Adjust the BFO control for the desired pitch and the AF gain and RF gain potentiometers for the desired audio output level.

2.5 Transmitter Operation

This section describes the operating procedures for the RT-224 transmitter.

2.5.1 Antenna and Counterpoise Deployment

Successful communication with the RT-224 transmitter depends greatly on the deployment of the antenna and counterpoise and on the selection of the correct antenna and counterpoise lengths for the particular frequency band in use.

2.5.2 Transmitter Frequency Source Operation

Three frequency sources may be used with the RT-224 transmitter; frequency synthesizer, CS-224 switched crystal oscillator, and front panel crystal.

2.5.2.1 Frequency Synthesizer

The frequency synthesizer provides the most flexible operating mode. This unit is plugged in the upper right compartment of the TAR-224 Radio Set. The desired operating frequency is set by four knobs on the synthesizer front panel. The transmitter doubles the source frequency from 12 to 24 MHz; therefore, in the 12 to 24 MHz band, the frequency source should be set to one-half of the desired output frequency.

2.5.2.2 CS-224

One of 30 crystals may be selected with the two XTAL SELECTOR switches (see figure 2-1, upper left). The CS-224 plugs in the upper right compartment of the TAR-224. The crystal frequency allocation for a particular switch position may be marked on a chart printed on the top side of the CS-224 and inside the dust cover. The numbering system runs from 00 to 29. The operating frequency range of the CR-78/U crystals in the CS-224 is 3 MHz to 12 MHz (use CR-89/U crystals from 2 MHz to 12 MHz). As the transmitter doubles the source frequency from 12 to 24 MHz, one-half the desired output frequency should be selected in the 12 to 24 MHz frequency range. These crystals are not supplied with the CS-224.

2.5.2.3 Front Panel Crystal

A crystal socket is provided on the TAR-224 front panel for CR-18/U crystals. Parallel resonant crystals with 32 picofarad capacitances are selected for the 2 to 12 MHz frequency range. As the transmitter doubles the source frequency from 12 to 24 MHz, a crystal frequency corresponding to one-half the desired output frequency should be selected in the 12 to 24 MHz frequency range.

2.5.3 Transmitter Tuning

The following is the procedure used in tuning the transmitter. (Refer to table 2-1 for a description of the controls).

- a. Determine transmitting frequency and select the proper antenna.
- b. Deploy antenna.
- c. Select d-c power source (internal battery or external source) as outlined in paragraph 2.6.
- d. Set transmitter frequency source to proper frequency as outlined in paragraph 2.5.2 (one-half of the desired output frequency from 12 to 24 MHz).
- e. Turn the BAND switch to proper position.
- f. Set MODE switch to RCVR/XMTR.
- g. Pull out the TUNE knob to coarse tune the transmitter. When coarse tuning is accomplished, the motor stops.

NOTE

If the transmitter cannot match the load, the antenna matching network will continue to cycle. Do not push transmitter tune knob in while motor is still running. To stop motor when it continues to cycle turn the mode switch to RCVR.

CAUTION

Never operate transmitter without connecting antenna and counterpoise to proper terminals.

WARNING

High voltages exist at antenna while transmitting. Personnel should not come in contact with the radiating antenna.

- h. Depress hand key, push and adjust TUNE/AUTO-PULL/FINE-PUSH control for peak reading on TUNE/VOLTS meter. This adjustment tunes the transmitter power amplifier.

2.5.4 Transmitter Keying

The transmitter may be keyed one of three ways: front panel key, external hand key, or medium speed keyer. The transmission may be monitored by using the handset and listening to the sidetone.

2.5.4.1 Front Panel Key

The front panel key has two adjustments: key knob travel and tension. Travel may be adjusted by rotating the screw on the end of the hand key. Clockwise rotation reduces travel. Tension in the key is adjustable by rotating the screw in the middle of the key. Clockwise rotation increases the spring tension. A lock also is provided. The screw with the large knurled nut will lock the key for continuous transmission.

2.5.4.2 External Key

An external hand key may be used and plugged into one of the PHONE/KEY jacks, or the wire lead of the external key may be terminated with spring sleeve key connectors which are then connected to the hand key located on the TAR-224 front panel. The transmitter is keyed by grounding the key line. The line to the external hand key should be shielded to prevent excessive RF pick-up. The shield may be used as the key line ground return. This key is not supplied with the set.

2.5.4.3 Medium Speed Keyer

The transmitter is initially tuned to the desired frequency using the hand key (as described in paragraph 2.5.3). The keyer is connected to the transmitter through PHONE/KEY jack 1A1J1 or PHONE/KEY jack 1A1J2 using an interconnecting cable and plug. A pre-recorded cartridge is connected to the keyer. Holding the toggle switch in the IDY position transmits a series of pulses for identification purposes. Holding this switch in the OPR position transmits the recorded message. The transmission may be monitored by listening to the sidetone output in the headset.

2.5.5 Amplitude Modulation Operation

For amplitude modulation operation of the transmitter, a microphone or a handset is connected to the transmitter through PHONE/KEY jack 1A1J1 or PHONE/KEY jack 1A1J2 on the front panel. The transmitter is then tuned as outlined in paragraph 2.5.3. To amplitude modulate the transmitter, the key on the mike or the handset is depressed. If the microphone is of the noise cancelling type, the operator must speak with the mike close to his lips.

2.6 Power Sources

The TAR-224 may be powered by either an internal battery or an external +12-volt high current source (such as a battery power supply or handcrank generator).

2.6.1 Internal Battery (TYPE-224)

The internal battery is located under a waterproof cover in the lower left hand corner of the radio set (see figure 2-1). The battery voltage may be monitored by pushing the TEST POWER switch on the receiver front panel and reading the terminal voltage on the TUNE/VOLTS meter. The meter reading must be out of the red area. If the battery voltage drops below 10 volts, the battery is automatically disconnected from the set. Depress the RESET button to reconnect. Holding the RESET button down will keep a low battery in the system.

CAUTION

Allowing the battery to completely discharge can damage the battery.

2.6.1.1 Internal Battery Charging

To charge the internal battery use a current limited supply, adjustable from 0 (approximately) to 5.0 amperes. Initially, with the power off, adjust current control for low output current and connect supply to

pin C of power input connector 1A1J5 (see figures 2-1 and 3-3). Turn power supply on and adjust current control on supply to allow charging at the rate indicated on the battery.

CAUTION

To prevent severe damage to the internal battery, DO NOT charge a DISCHARGED battery (terminal voltage 10 volts or less under load) for more than 14 hours. If the battery is only partially discharged, charge for a proportionate period of time.

2.6.2 External Source

When an external source is connected to the external POWER receptacle on the front panel, it will energize relay 1A1A3K2 taking the internal battery out of the circuit.

The external source should be capable of supplying 10.8 to 13.2 volts at 5.9 amperes.

CAUTION

When using an external source, the input leads should be as short as possible and well shielded to prevent the high RF fields from the transmitter from upsetting the performance of the external source.

CHAPTER 3

RADIO SET TAR-224 CIRCUIT DESCRIPTION

3.1 Scope

This chapter discusses the circuitry in the TAR-224. The circuitry is broken down into three major groups: the receiver, the transmitter, and the power sources. Each group is broken down further with the discussion of its various circuits.

3.2 TAR-224 Radio Receiver-Transmitter Circuit Description

For purposes of discussion the receiver and transmitter are described first in functional block diagram form followed by a detailed description of each individual circuit. The power sources are described in detail.

a. Receiver RR-224

- (1) Figure 3-1 Block Diagram
- (2) Figure 3-2 Schematic Diagram
- (3) Figure 3-3 Schematic Diagram Front Panel Radio Set TAR-224
- (4) Figure 3-4 Wiring Diagram

b. Transmitter RT-224

- (1) Figure 3-5 Block Diagram
- (2) Figure 3-6 Schematic Diagram
- (3) Figure 3-3 Schematic Diagram Front Panel Radio Set TAR-224
- (4) Figure 3-7 Wiring Diagram

3.3 RR-224 Receiver Functional Block Diagram Description

As shown in figure 3-1, the antenna matching network consists of a bandswitched, single-tuned circuit to match a 50-ohm source to the RF amplifier input. The RF amplifier provides gain stability and high output impedance. The output is fed to the mixer. The mixer heterodynes the RF amplifier output with the output of the capacitor-tuned common-base local oscillator. The RF output of the mixer is coupled directly to a narrow-band ceramic ladder filter. The center frequency of the IF filter is 455 kHz with a -6db bandwidth of 6 kHz \pm 0.6 kHz. The output signal of the IF filter is fed to the IF amplifier where it is amplified to a detectable level. In the AM mode, the IF output signal is applied to a conventional diode envelope detector which has two outputs. One output controls the AM-AGC amplifier and the other controls the audio amplifier. In the CW mode, the IF output of the IF amplifier is fed to a product detector where it is mixed with the BFO output and then fed to the audio amplifier and the CW-AGC amplifier. The BFO is adjustable over \pm 3 kHz for the signal conversion in the product detector in CW mode. A front panel switch applies either the AGC amplifier output or the RF gain control output to the AGC bias to adjust the gain of the RF amplifier and the first and second stages of the IF amplifier. The audio amplifier is capable of a minimum one milliwatt output across a 500-ohm load.

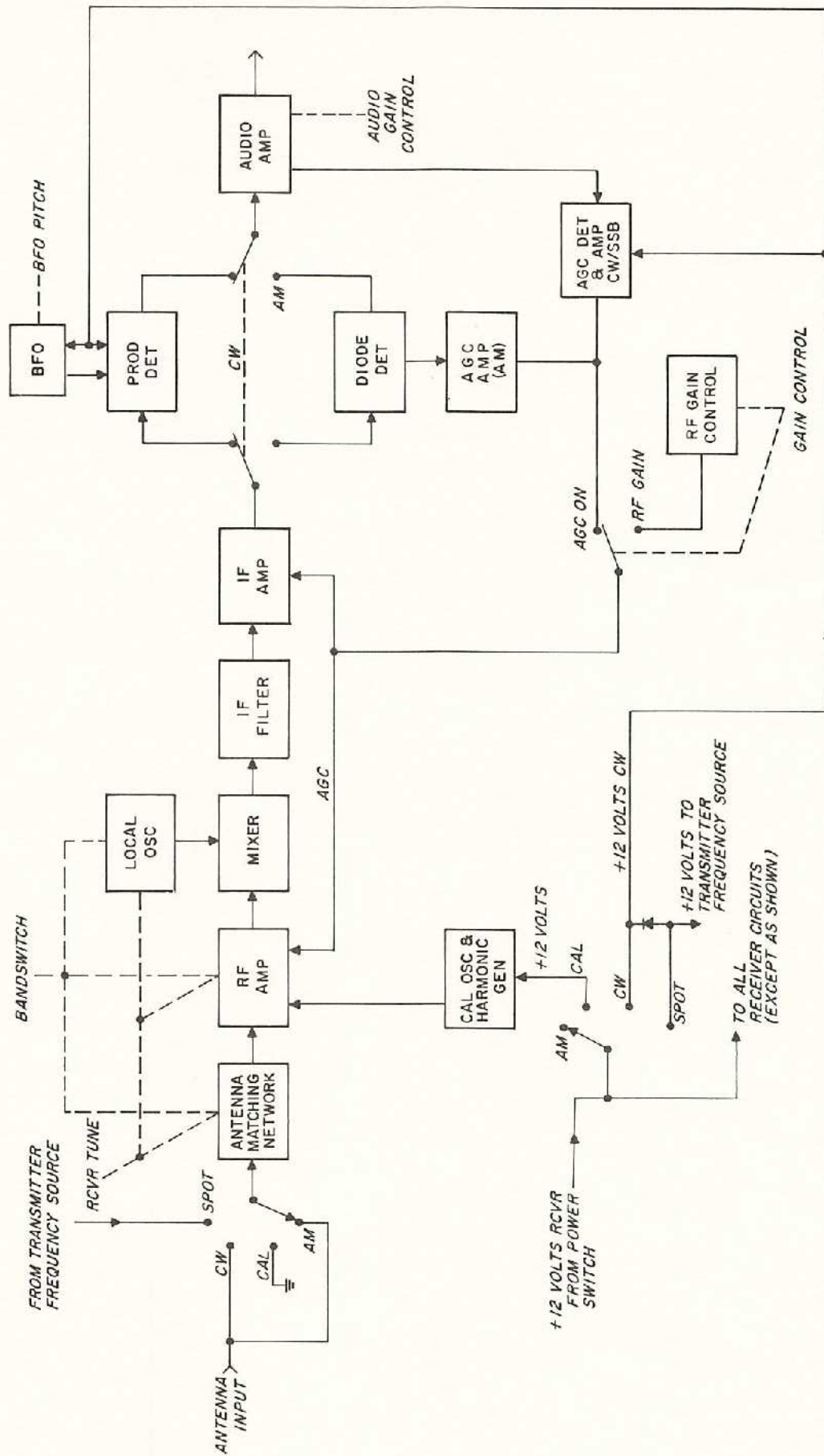

Figure 3-1. RR-224 Block Diagram

3.4 RR-224 Receiver Individual Circuit Description

The following circuit descriptions are supported by figures 3-2, the RR-224 schematic diagram, 3-3, TAR-224 front panel, and 3-4, RR-224 wiring diagram.

3.4.1 Antenna Matching Network Detailed Description (1A3A2)

The RF signal input from the antenna change-over relay 1A4K4 is coupled to one pole of the RCVR mode switch 1A1S5. In the AM or CW positions the RF input signal is fed to the RF amplifier 1A3A3Q1. In the CAL or SPOT positions, the calibration signal is fed to the RF amplifier 1A3A3Q1 input. The antenna matching network circuitry is on one circuit card in the tuner section of the receiver. Tunable transformers for each of four bands are tapped to provide the required impedance transformation between the antenna and the RF amplifier. These transformers are operated at as high a Q as is practical consistent with good receiver sensitivity. This is to achieve the required image rejection. Section 1A3C1-A of the precision-ganged variable capacitor tunes the antenna matching transformers. It varies from approximately 8 to 86 picofarads, and has a straight line frequency versus capacitor rotation characteristic. Capacitors C2, C6, C9, and C13 are trimmers that adjust the minimum capacity across each of the tuned transformers.

3.4.2 RF Amplifier Detailed Description (1A3A3)

The first stage of the RF amplifier is physically located on the antenna matching network circuit board. The RF signal from the antenna tuned circuit is coupled to the RF amplifier through capacitor voltage dividers. The RF amplifier consists of 1A3A2Q1 and 1A3A3Q1 coupled as a cascade amplifier, with 1A3A2Q2 providing AGC action. 1A3A2Q1 is a common emitter stage coupled directly to the emitter of 1A3A3Q1 common base stage, through the diode CR1. This amplifier provides good stability and a high output impedance at the collector of 1A3A3Q1. The gain of the amplifier is partially controlled by varying the impedance in the emitter of 1A3A2Q1 with transistor 1A3A2Q2. Resistor 1A3A2R4 provides a fixed amount of emitter degeneration. For maximum gain, 1A3A2Q2 is saturated, resulting in a low impedance from the emitter of 1A3A2Q1 to ground. As 1A3A2Q2 is brought toward cutoff, its collector impedance increases, causing increased emitter degeneration in transistor 1A3A2Q1. The maximum emitter impedance of 1A3A2Q1 is controlled by the series combination of 1A3A2R5 and 1A3A2L1. These values provide the required degeneration, while maintaining a necessary minimum current flow through 1A3A2Q1. Additional gain control is obtained by the combination of CR1, C1, and R2 in series with 1A3A2Q1 and 1A3A3Q1. For maximum gain, CR1 is forward biased, resulting in a low impedance between the two stages. Reducing the current through 1A3A2Q1 with the AGC transistor 1A3A2Q2, and lowering the base bias on 1A3A3Q1, results in CR1 being back-biased. The impedance between 1A3A2Q1 and 1A3A3Q1 increases to a value determined by R2 resulting in additional signal attenuation. Both modes of gain control are controlled by the AGC input.

Since the output impedance of 1A3A3Q1 is high, it is coupled through the bandswitch to the top of RF tuned transformers 1A3A3A2T1, T2, T3 and T4. These transformers are tuned by a second section of the variable capacitor 1A1C1-B, which is identical to 1A1C1-A. Trimmer capacitors 1A3A3A2C2, C6, C10 and C14 are also used across these tuned transformers. The tuned transformers are tapped so the input impedance of the buffer amplifier 1A3A7Q1, located in the mixer, is transformed to the desired load impedance at the collector of 1A3A3Q1.

3.4.3 Local Oscillator Detailed Description (1A3A4)

Transistor Q2 is a common base oscillator. The collector of Q2 is connected through the bandswitch to the tuned transformer T1, T2, T3 or T4 depending on the BAND selected. The network of CR2 and R4 suppresses parasitic oscillations. The location of the taps on the tuned transformers are at a relatively low impedance point to minimize transformer detuning caused by a change in the output reactance of the transistor, and to maintain a high loaded Q. The resonant frequency of the tuned circuit is adjusted by the local oscillator section of variable capacitor 1A1C1-C. This section of the capacitor varies from approximately 8 to 24 picofarads and is cut for straight line frequency versus capacitor rotation of band 4, the highest frequency band. On the lower three frequency bands, the ratio of the maximum to minimum

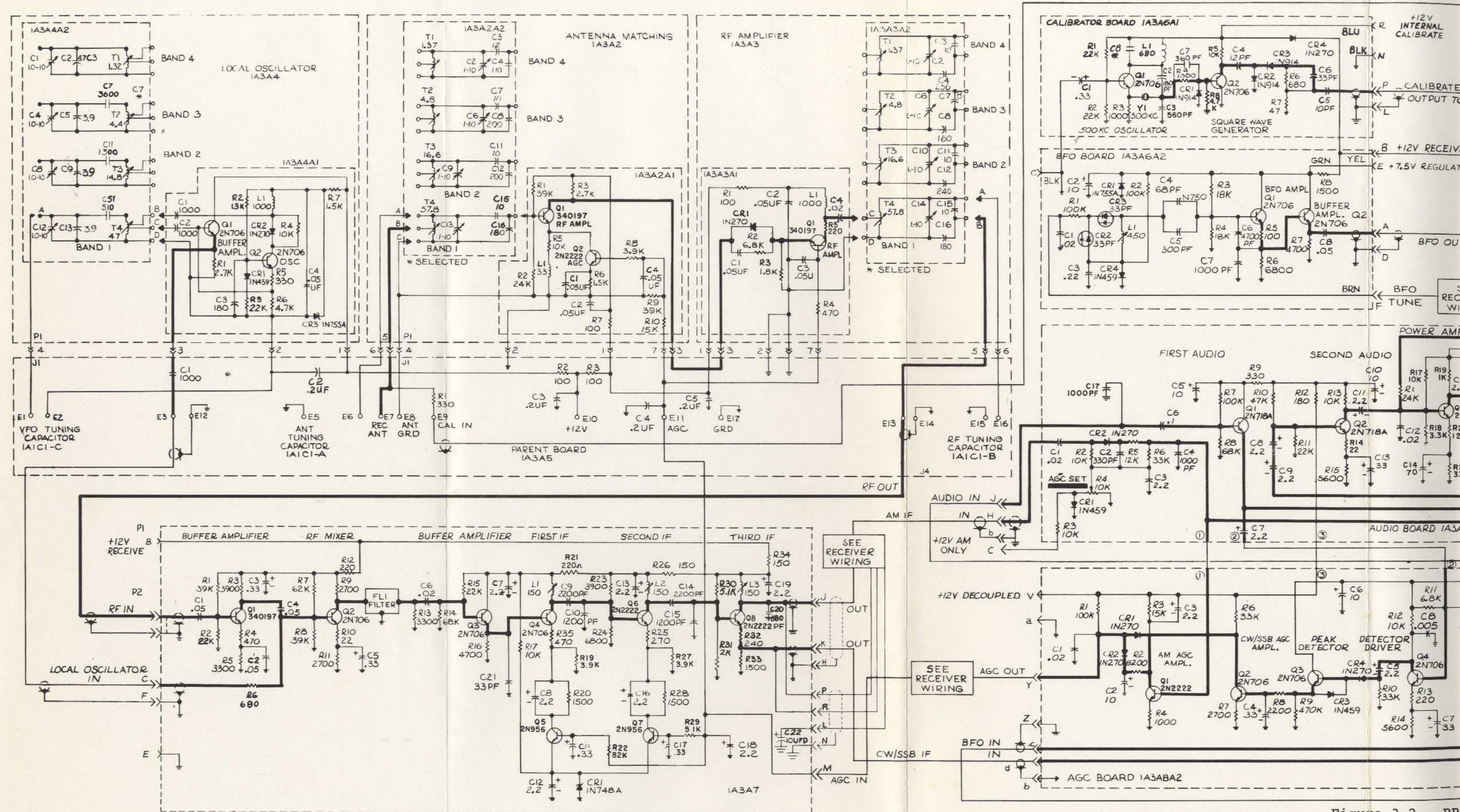

Figure 3-2. RR

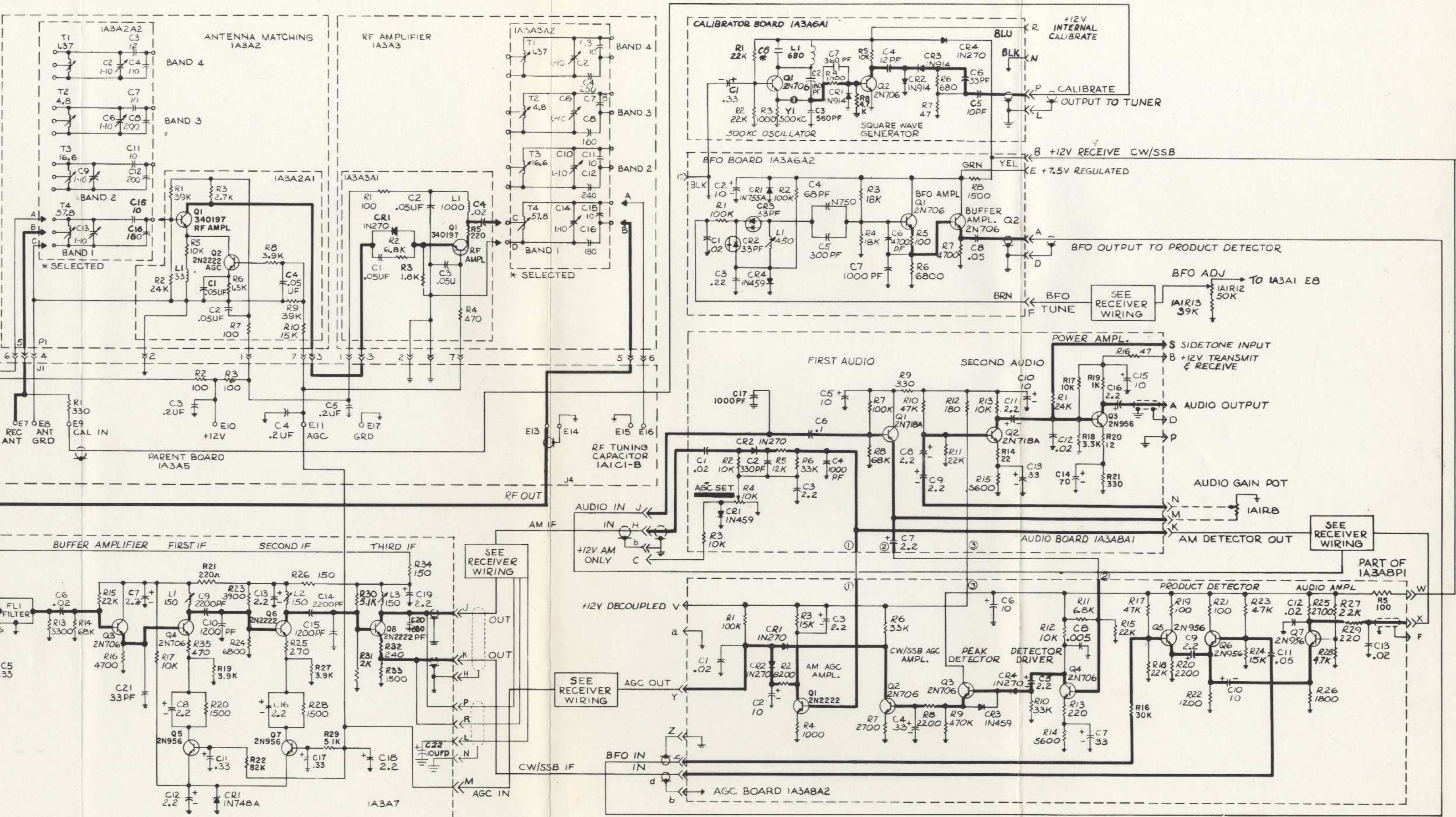
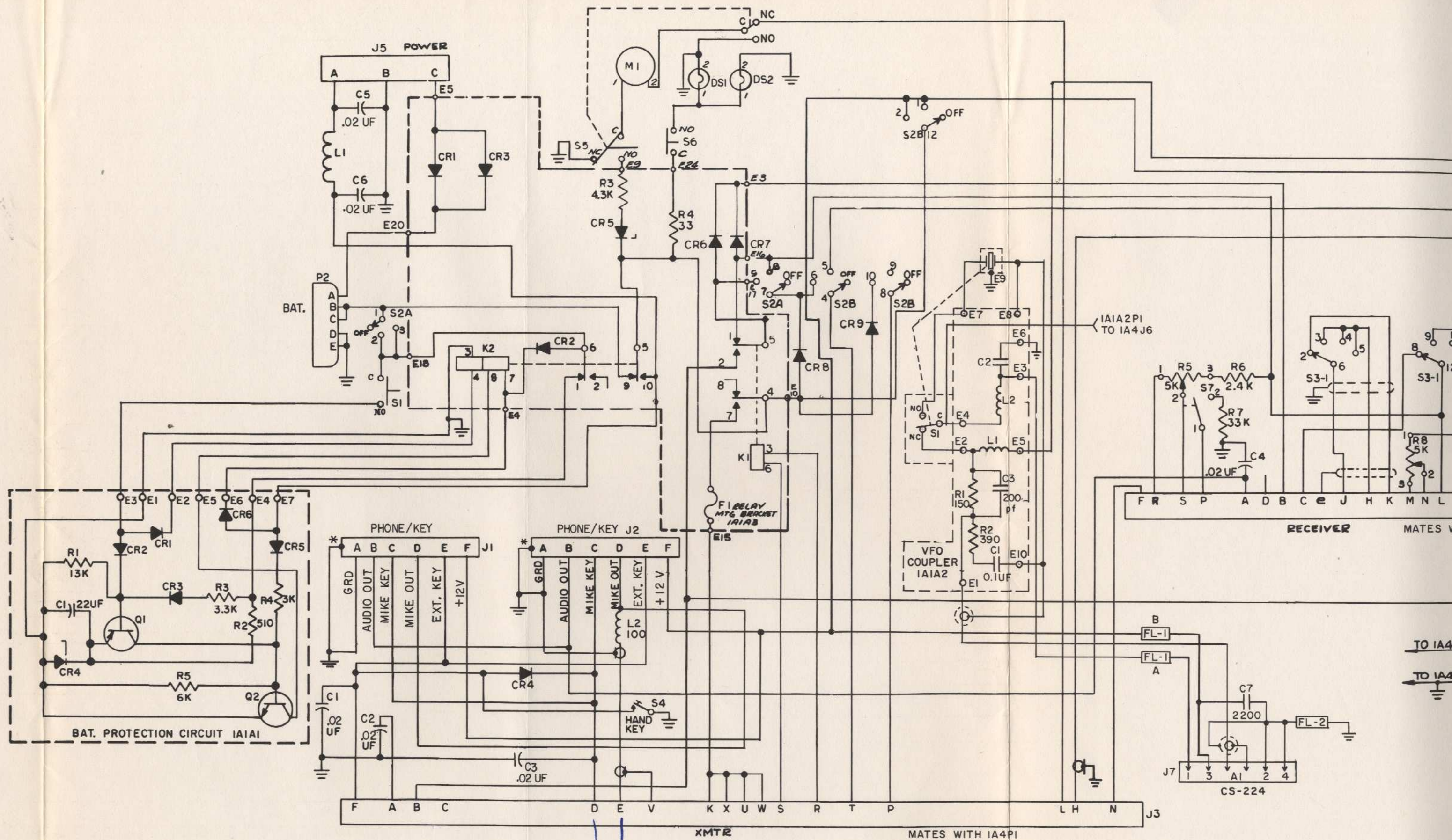
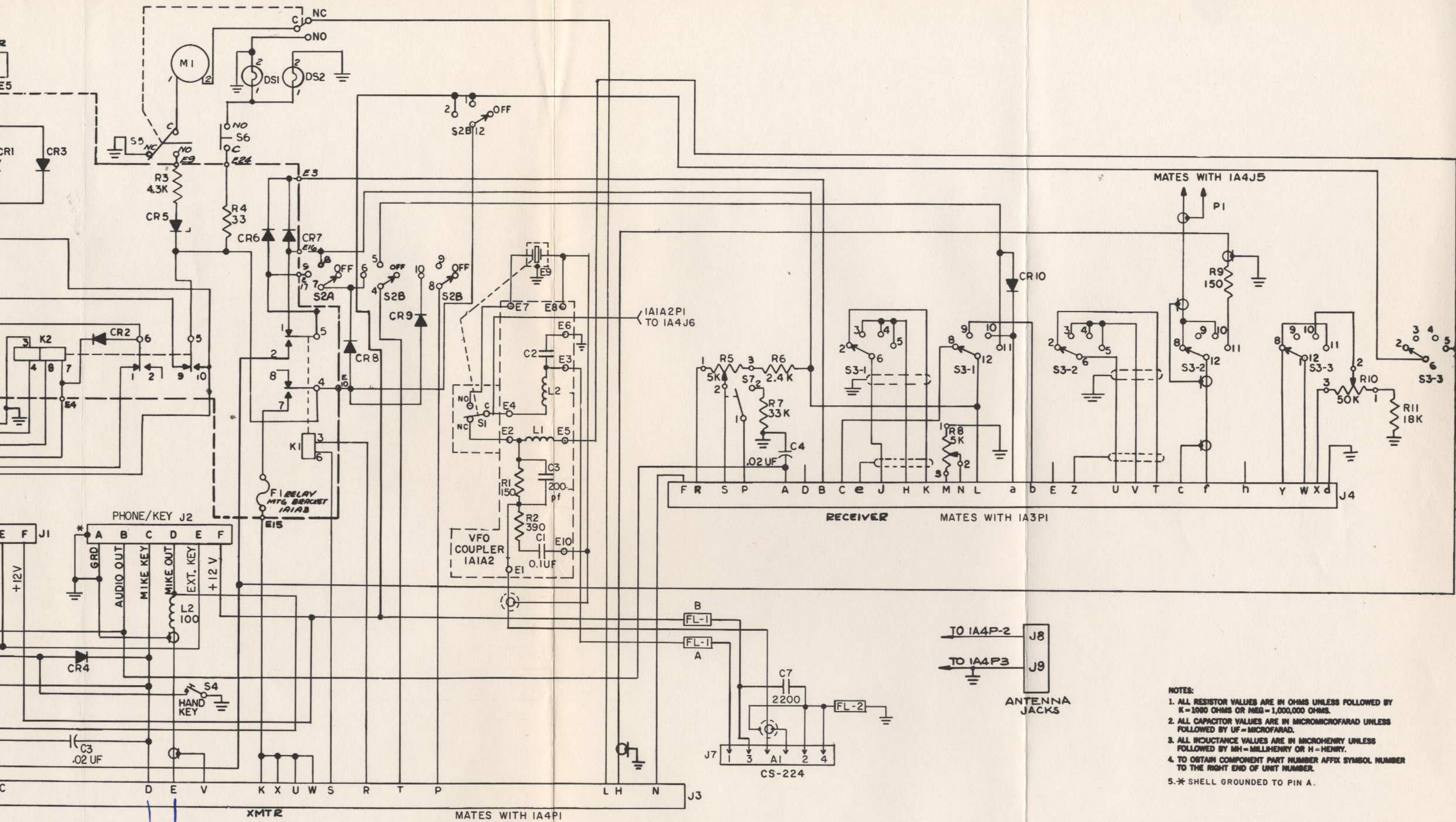

Figure 3-2. RR-224 Schematic Diagram



Figure



- NOTES:
1. ALL RESISTOR VALUES ARE IN OHMS UNLESS FOLLOWED BY K=1000 OHMS OR MEG=1,000,000 OHMS.
 2. ALL CAPACITOR VALUES ARE IN MICROMICROFARAD UNLESS FOLLOWED BY UF= MICROFARAD.
 3. ALL INDUCTANCE VALUES ARE IN MICROHENRY UNLESS FOLLOWED BY MH= MILLHENRY OR H= HENRY.
 4. TO OBTAIN COMPONENT PART NUMBER AFFIX SYMBOL NUMBER TO THE RIGHT END OF UNIT NUMBER.
 5. * SHELL GROUNDED TO PIN A.

Figure 3-3. TAR-224 Front Panel Schematic Diagram

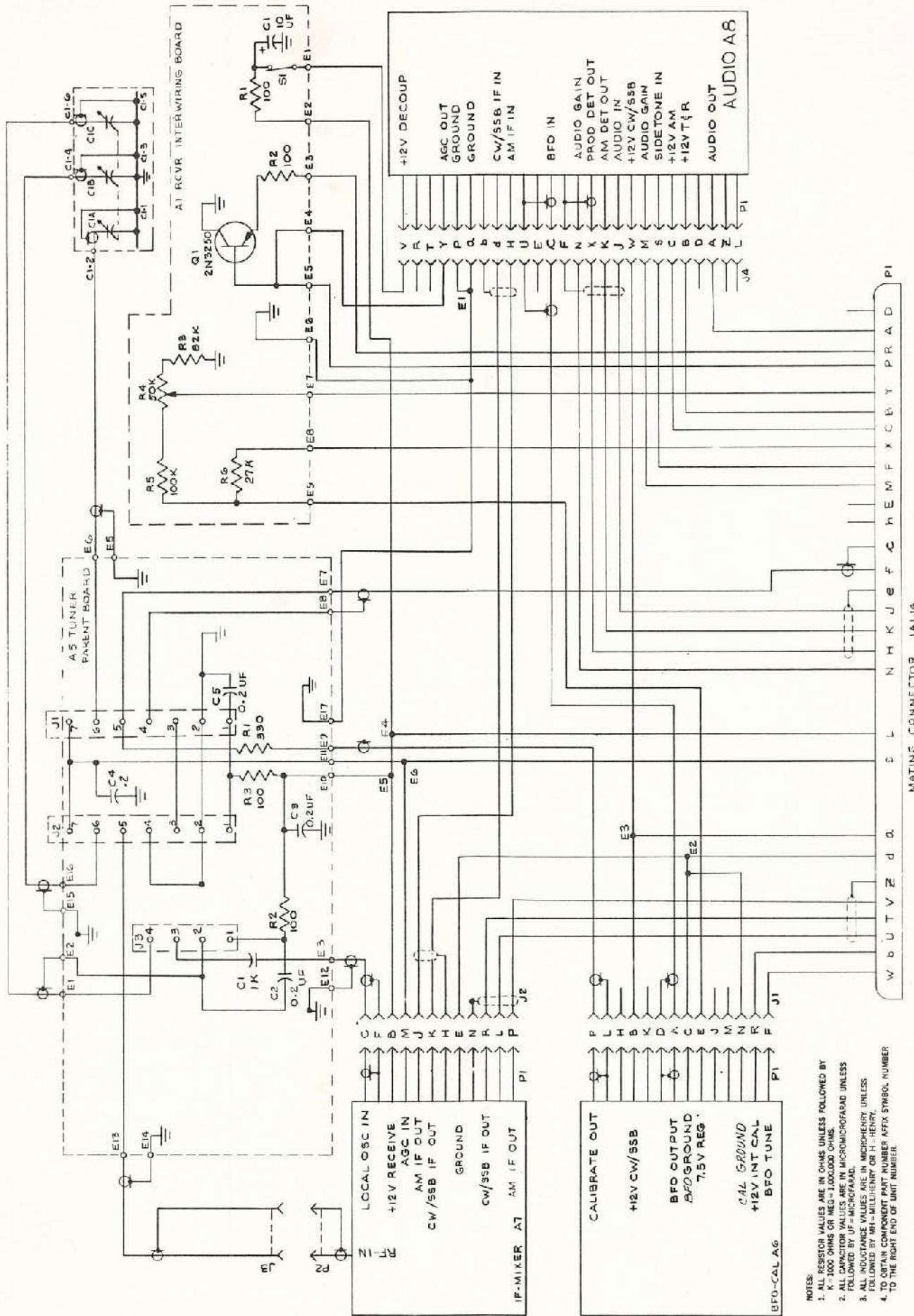

Figure 3-4. RR-224 Wiring Diagram

- NOTES:
1. ALL RESISTOR VALUES ARE IN OHMS UNLESS FOLLOWED BY K=1000 OHMS OR M=1,000,000 OHMS.
 2. ALL CAPACITOR VALUES ARE IN MICROFARAD UNLESS FOLLOWED BY UF=MICROFARAD.
 3. ALL INDUCTANCE VALUES ARE IN MICROHENRY UNLESS FOLLOWED BY MH=MILLI-HENRY OR H=HENRY.
 4. TO OBTAIN COMPONENT PART NUMBER AFX SYMBOL NUMBER TO THE RIGHT END OF UNIT NUMBER.

capacity required across the tuned transformers is less than that of band 4. To permit using the variable capacitor on these bands, the maximum to minimum capacity ratio is reduced by placing it in parallel with a capacitive pi network. Capacitors 1A3A4A2C2, C5, C9, and C13 are used for temperature compensation and trimmer capacitors 1A3A4A2C1, C4, C8, and C12 to set the minimum capacity across each of the tuned transformers.

The secondary winding on the tuned transformers (for oscillator positive feedback) are coupled to the emitter of Q2 through R5. The output signal from the secondary winding is also coupled to the base of the common collector buffer amplifier Q1. The local oscillator output at the emitter of Q1 is capacitively coupled to the mixer input through 1A3A5C1.

3.4.4 IF Mixer, IF Filter, IF Amplifier Detailed Description (1A3A7)

The RF signal input to the mixer is fed to a low gain common emitter amplifier Q1 that acts as a buffer amplifier between the RF amplifier and the mixer. This also provides additional reverse attenuation of the local oscillator signal. The buffer amplifier output is capacitively coupled to the base of the RF mixer transistor Q2. The local oscillator output also is fed to the base of the RF mixer transistor. Q2 is a common emitter amplifier with the RF signal and the local oscillator signal summed at the base. The local oscillator level is maintained much higher than the RF signal to ensure a linear conversion. The collector of Q2 is coupled directly to IF filter FL1 whose bandpass determines the IF bandwidth. The IF filter is a narrow band ceramic filter with a center frequency of 455 kHz. The -6 db bandwidth is $6.0 \text{ kHz} \pm 0.6 \text{ kHz}$ and the -60 db bandwidth is less than 11.0 kHz. The output of the filter is coupled to an emitter follower, Q3, that maintains a constant load impedance for the filter and provides a low impedance drive for the first stage in the IF amplifier. The first stage of the IF amplifier consists of common emitter Q4, with a low Q single-tuned circuit as the collector load. The input to the second IF amplifier stage is transformed to the desired load impedance value by capacitive divider C9 and C10. L1 is a variable inductor which provides the center frequency adjustment of the tuned circuit. Transistor Q5 provides a variable impedance in the emitter circuit of Q4 to control the gain of the stage. The emitter of Q5 is biased at approximately +4 volts by Zener diode CR1. The base of Q5 is coupled to the AGC bus through R22. Resistor R35 provides a fixed amount of degeneration for the stage. The maximum emitter impedance and the minimum collector current of Q4 is determined by R19.

The operation of the second IF amplifier stage is identical to that of the first IF amplifier stage. When the receiver is operated in the CW, CAL, or SPOT mode, the third IF amplifier stage is operated as an emitter follower. Capacitor 1A1C2 bypasses the collector of Q8 through one wafer of switch 1A1S5. The IF signal is coupled from the emitter of Q8 to the product detector. In the AM mode, 1A3A1C2 bypasses the emitter of Q8. The collector circuit is a low Q single-tuned circuit consisting of L3 and C20. The collector is capacitively coupled to the AM detector to accommodate the large difference in drive levels required by the AM and product detectors.

3.4.5 AM Detector (1A3A8A1), AM Automatic Gain Control (1A3A8A2) Detailed Description

When using AM operation, a conventional envelope detector is used for both audio and AGC detection. The AM IF signal is detected by 1A3A8A1CR2 and the output is filtered by 1A3A8A1C2, R5, R6 and C4.

The AM detector output is fed through the RCVR mode switch to the audio amplifier 1A3A8A1. The AM detector output is also fed to the AGC board 1A3A8A2. The AM detected signal is directly coupled to the base of Q1 on the AGC board 1A3A8A2. The AGC circuitry of 1A3A8A1R3, R4, and CR1 sets the zero signal bias on the base of 1A3A8A2Q1. 1A3A8A1CR1 also functions as a temperature compensator for d-c bias on the base of 1A3A8A2Q1, a common emitter d-c amplifier. The amplifier audio signal at the output of 1A3A8A2Q1 is filtered by 1A3A8A2C3, R2, and R3. The amplifier AGC signal is then fed through 1A3A8A2CR2 of a diode OR gate to the base of emitter follower 1A3A1Q1. With the RF gain control 1A1R4 in the AGC position (fully ccw), the AGC switch is open and the emitter of 1A3A1Q1 follows the output of the AGC amplifier. When the RF gain control is adjusted over its range, the AGC switch is closed. The base of 1A3A1Q1 is fixed biased by 1A1R6. The AGC bus is connected to the wiper arm of RF gain potentiometer 1A1R4. The RF amplifier and the IF amplifier gains are decreased as the AGC voltage varies from 8 volts to 3.5 volts.

3.4.6. Beat Frequency Oscillator (1A3A6A2) and Product Detector (1A3A8A2) Detailed Description

The beat frequency oscillator (BFO) is a modified Clapp oscillator circuit with back-to-back varactors 1A3A6A2CR2 and CR3 that provides tuning across 1A3A6A2L1. In the CW mode the varactors receive their bias from the wiper arm of 1A1R12, the VFO frequency control potentiometer. The potentiometer adjusts the frequency of the BFO approximately ± 3.0 kHz from the 455 kHz center frequency. In the CAL mode, the voltage varactors are biased by the divider consisting of 1A3A1R3, R4 and R5. Resistor 1A3A1R4 is adjusted for a BFO frequency of 455 kHz. The network, 1A3A6A2R2, CR4 and C1 provides temperature compensation for the varactors. Capacitors 1A3A6A2C4 and C5 compensate for temperature variations in inductor 1A3A6A2L1. The effect of load variations is minimized by emitter follower 1A3A8A2Q5 capacitively coupled to the BFO output.

The product detector, 1A3A8A2Q5, Q6 and Q7, heterodynes the IF signal down to an audio signal in the CW and calibrate modes. The BFO output signal is coupled to the base of 1A3A8A2Q5. The CW IF output signal is coupled to the base of 1A3A8A2Q6. Mixing action takes place in the nonlinear base-emitter junctions of these transistors that are a-c coupled by 1A3A8A2C9. The resulting audio output is amplified by the common base stage 1A3A8A2Q7.

The CW AGC circuitry is located with the product detector circuitry. The AGC signal for CW operation is obtained by coupling the audio output of the first audio amplifier 1A3A8A1Q1 to 1A3A8A2Q4. Transistors 1A3A8A2Q4, Q3 and Q2 form a fast-attack, slow-decay, peak detector. High gain audio amplifier 1A3A8A2Q4 drives the rectifier diode 1A3A8A2CR4. The low output impedance of emitter follower 1A3A8A2Q3 permits the attack time constant, which is about 70 milliseconds, to be determined by 1A3A8A2C4 and R8. When the input level drops, 1A3A8A2Q3 is cut off and 1A3A8A2C4 discharges through the high impedance path of 1A3A8A2Q3 in parallel with the input impedance of 1A3A8A2Q2. The discharge time of 1A3A8A2C4 is approximately 3 seconds. The amplified AGC signal at the output of 1A3A8A2Q1 is coupled to the base of 1A3A1Q1 through 1A3A8A2CR1 of the AGC OR gate.

3.4.7 Audio Amplifier Detailed Description (1A3A8A1)

The audio signal from either the AM envelope detector or the CW product detector is coupled to the input of the audio amplifier through the RCVR mode switch 1A1S5. The first audio stage Q1 is an emitter follower that provides a high load impedance for the AM detector. The audio gain potentiometer 1A1R8 is the emitter resistor for this stage. The audio output of Q1 also is coupled to the CW AGC circuitry. The audio signal from the wiper arm of the audio gain control is a-c coupled to the second audio amplifier Q2, an RC-coupled, common-emitter stage. Resistor R14 provides fixed degeneration for this state of amplification. The output of Q2 is a-c coupled to the base of power amplifier Q3. This amplifier stage is designed to provide a minimum output of 1 milliwatt across a 500-ohm load. The output of Q3 is capacitively coupled to the earphones. The supply voltage for the last stage is independent of the supply voltage for the rest of the receiver. The last stage remains energized both in the receive and transmit modes. In the transmit mode the stage amplifies the sidetone signal that is coupled to its base through R1.

3.4.8 Internal Calibration Oscillator Detailed Description (1A3A6A1)

The internal calibration oscillator consists of a 500 kHz crystal oscillator, a diode-transistor shaping circuit, and a differentiator. The crystal oscillator, Q1, is a common base Colpitts type circuit. Crystal Y1 is placed in the feedback path and is operated in the series resonant mode. Inductor L1 and the series combination of C2 and C3 form a parallel resonant circuit at the resonant frequency of the crystal. Capacitors C2 and C3 are so selected that the impedance transformation from the collector to the emitter is the correct value to sustain oscillation. The output of the oscillator is coupled to the base of Q2, a square wave generator. The combination of C4, CR2 and CR3 differentiates the output of Q2. The positive output peaks are clipped by CR2 leaving a series of negative spikes. These spikes, which have a high harmonic content, are coupled to the input of the receiver antenna matching network through C5 and 1A3A5R1.

3.5 RT-224 Transmitter Functional Block Diagram Description

As shown in figure 3-5, input signals in the 2 MHz to 12 MHz frequency range are supplied by the frequency source in use, CS-224, frequency synthesizer, or external crystal CR-18/U. The frequency source signal is fed to the low level module and is shaped and amplified to a sufficient level to drive the push-pull operated driver-final amplifier. The output of the driver-final amplifier is fed to the RF sampler where the forward and reflected power is sensed and its output used to control the output level of the low-level module. The RF signal, through the RF sampler, is coupled to the antenna matching network and then through the antenna tuning module to the antenna. The antenna matching network is coarse-tuned automatically by a motor, however, fine tuning is achieved through a front panel control. Proper tuning is indicated on the front panel TUNE meter.

3.6 RT-224 Transmitter Circuit Description

The following circuit descriptions are supported by figures 3-6 RT-224 schematic diagram, 3-3 TAR-224 front panel, and 3-7 RT-224 wiring diagram.

3.6.1 Low Level Module Detailed Description (1A4A7)

The low level module is composed of seven stages: crystal oscillator-amplifier, buffer amplifier, doubler amplifier, automatic level control, second buffer amplifier, class A amplifier, and the pre-driver amplifier. Each of these seven circuits are detailed below.

a. **Crystal Oscillator-Amplifier.** The first stage Q1, is designed to operate either as an amplifier or as an oscillator. A crystal inserted into the external crystal socket on the front panel mechanically activates switch 1A1S7-C. This places the crystal across the amplifier input terminals. The high reactive impedance presented by the crystal, plus the capacitive voltage divider (C1, C2, and C3) that provides feedback to the base, causes the transistor to operate as a modified Pierce oscillator. When the crystal is removed the amplifier input is connected to the CS-224 crystal matrix or the frequency synthesizer depending on which is plugged into the compartment on the front panel. Stage Q1 then functions as an emitter-follower because the impedance across the input terminals will not cause oscillation. The output of Q1 is taken from the emitter in series with R4 and is capacitively coupled through C6 and R8 to the base of buffer amplifier Q2. Zener diode CR1, with resistor assembly 340424 stabilizes the collector voltage of Q1 for any variation in battery voltage. The emitter load for Q1 is comprised of R3 and L2. Capacitor C2 trims the load capacitance to the required 32 pf for CR-18/U crystals. The combination of CR9, C31, R42, R43, and Q11 compose a negative feedback circuit for the oscillator which keeps the output of the emitter of Q2 at a constant level across the frequency range. The combination of CR9 and C31 form a detector circuit that rectifies the voltage at the junction of R10 and L3. This voltage determines the current into the base of Q11. The d-c current into the base of Q1 is set by the current in the collector of Q11, and the value of resistor R2. Since the oscillator output is determined by the bias current of Q1, the current in the collector of Q11 and the value of R2 determine the output voltage.

b. **Buffer Amplifier.** The buffer amplifier Q2 is an emitter follower operating as a class A amplifier. The gain of Q2 is such that only 1 milliwatt of power is required from the oscillator to produce a 6-milliwatt output. This gain removes any tendency for oscillator "pulling". Inductor L3 permits the buffer to drive highly capacitive loads without distortion caused by transistor cutoff.

c. **Doubler-Amplifier.** The doubler-amplifier stage is composed of transistors Q3 and Q4 performing dual functions, as a broadband doubler or as an amplifier, depending on the position of transmitter band switch S1. When operating in the 2 to 12 MHz frequency range, the stage will operate as an amplifier. When BAND switch S1 on the front panel is in the 2 to 12 MHz position, the transistors are switched to operate push-pull into broadband coupling transformer T1. When operating in the 12 to 24 MHz frequency range, the transistor Q4 output is switched to operate in parallel with Q3 at the broadband transformer T1. The output of buffer amplifier Q2 is capacitively coupled through C7, CR2, and CR3 to Q3 and Q4 respectively. The combination of R11, R12, CR2, and CR3 is used to bias Q3 and Q4 when a signal is on the key line. Resistors R15 and R13 provide emitter degeneration for Q3 and Q4 while R14,

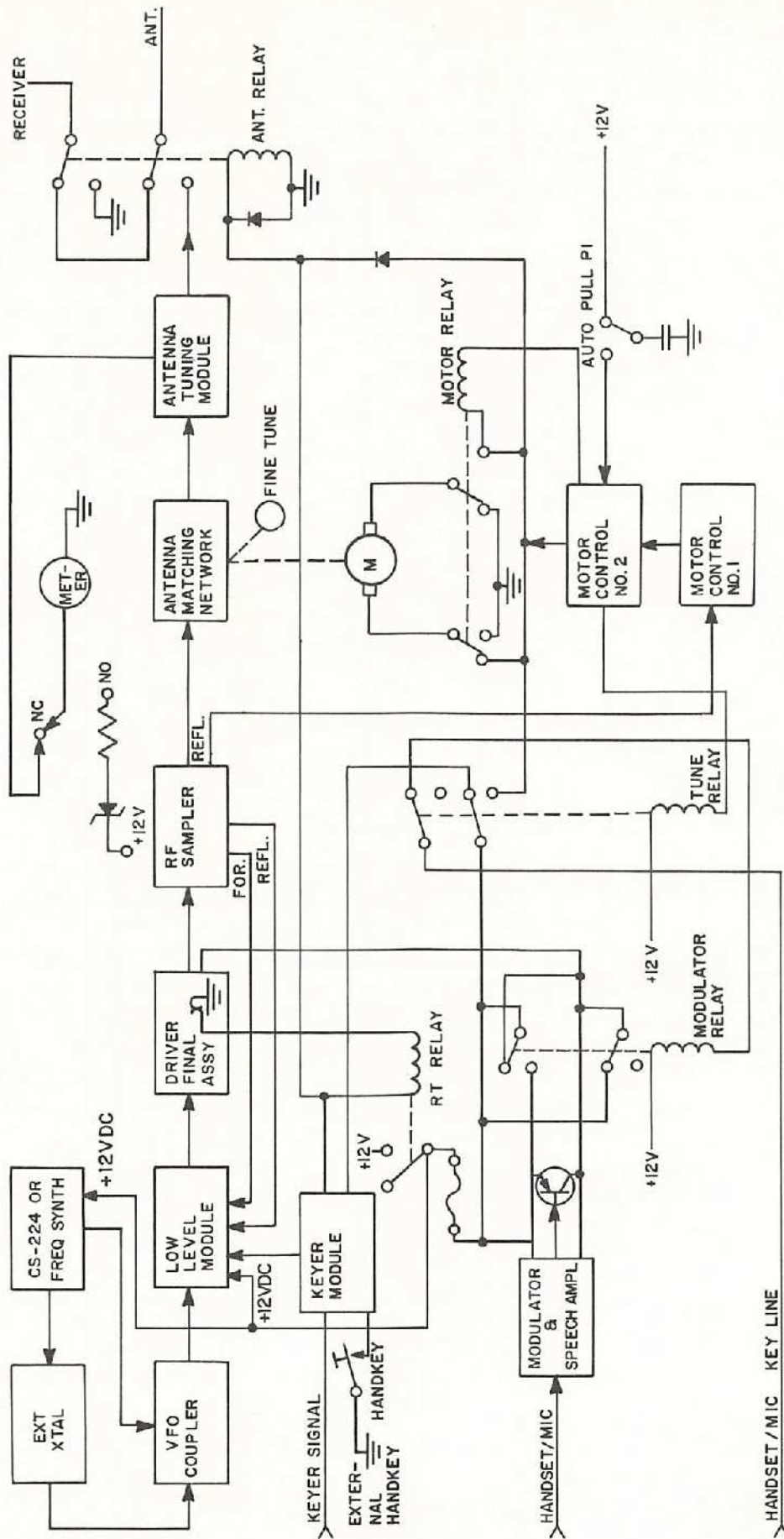
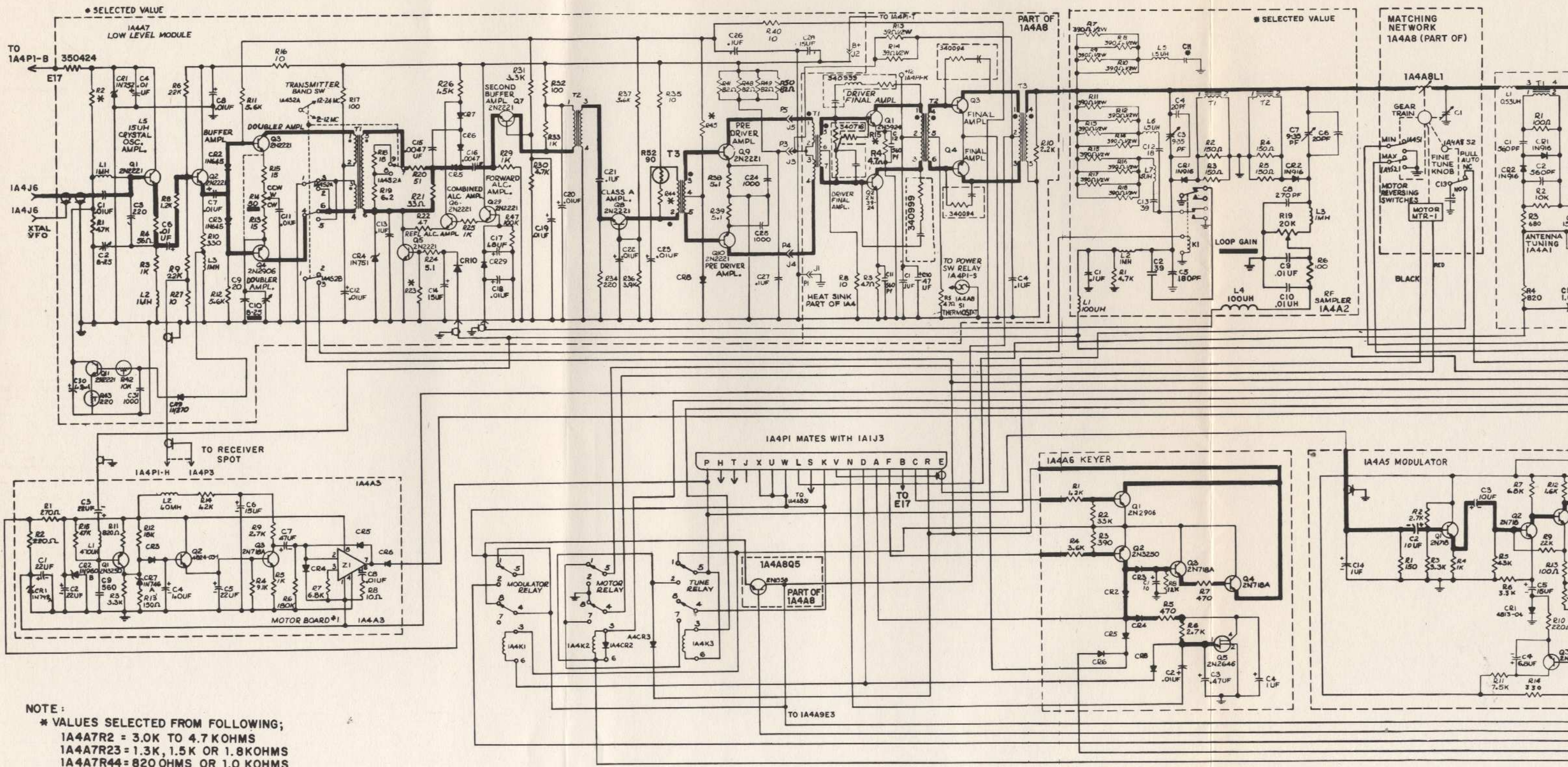

Figure 3-5. RT-224 Block Diagram



NOTE:
 * VALUES SELECTED FROM FOLLOWING;
 IA4A7R2 = 3.0K TO 4.7 KOHMS
 IA4A7R23 = 1.3K, 1.5K OR 1.8KOHMS
 IA4A7R44 = 820 OHMS OR 1.0 KOHMS
 IA4A7R45 = 910 OHMS OR 1.8 KOHMS
 IA4A8R15 = 0 OR 180 OHMS

REPLACE WITH VALUES IN SPECIFIC MODULE

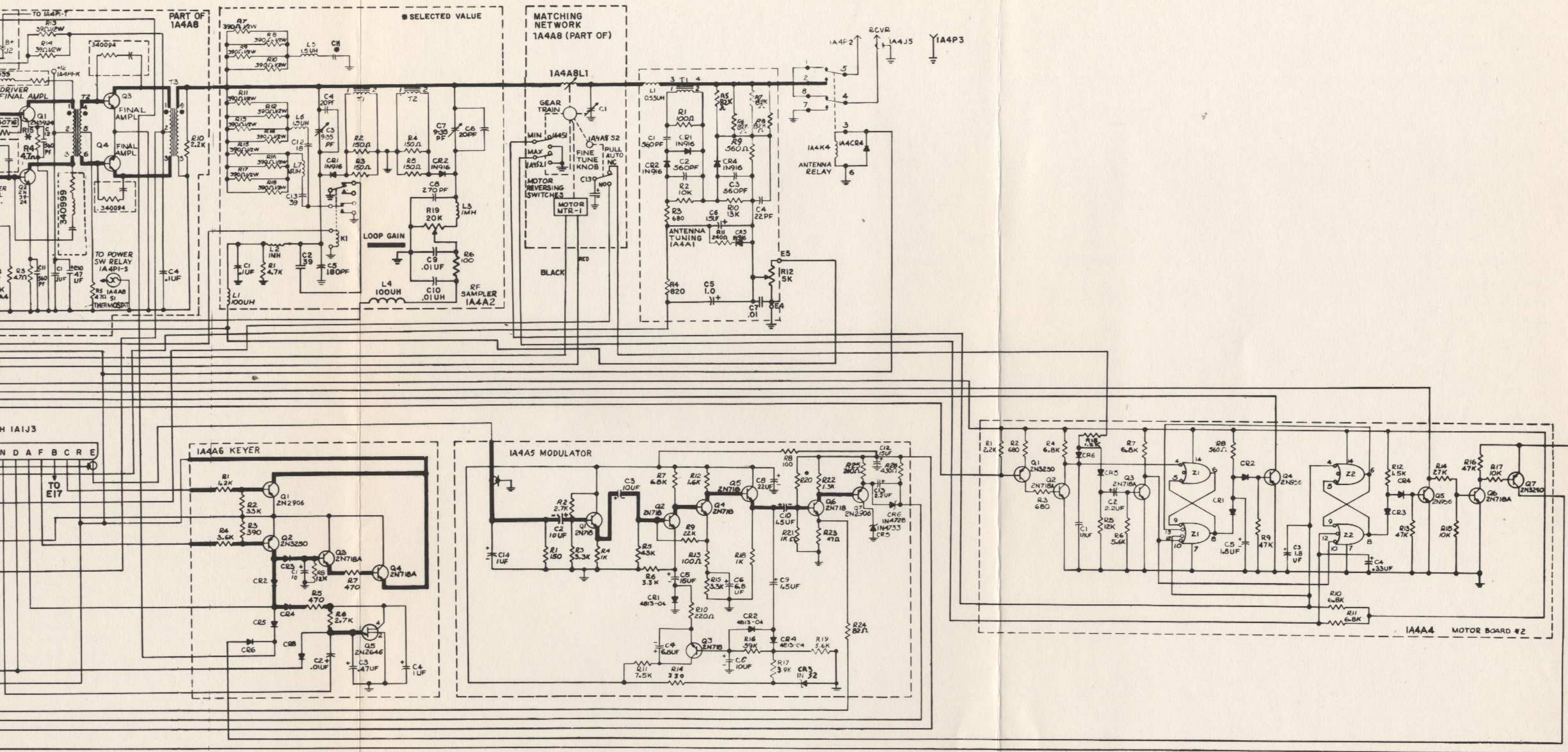
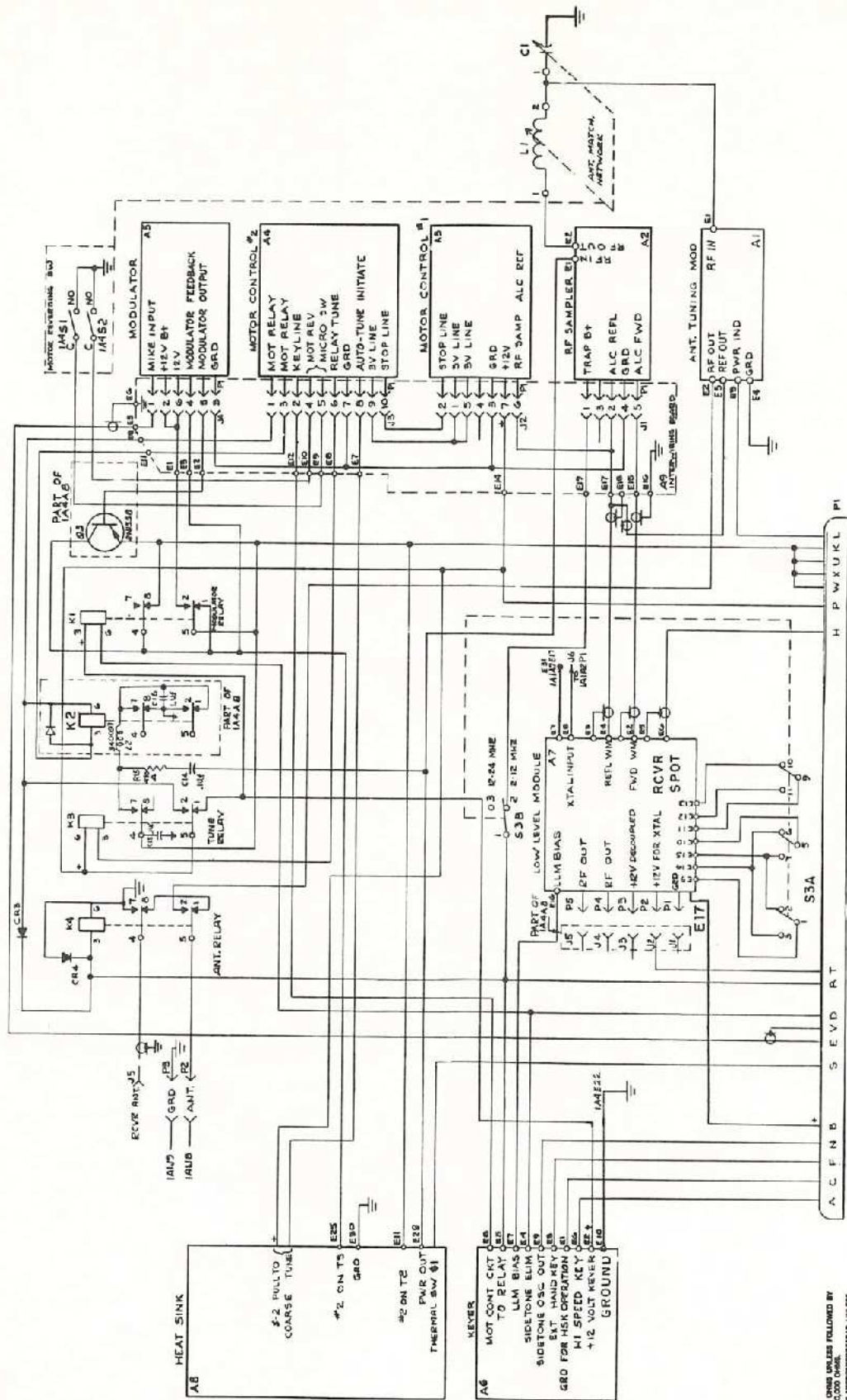

Figure 3-6. RT-224 Schematic Diagram



NOTE:
 1. CAPACITOR VALUES ARE IN OHMS UNLESS FOLLOWED BY
 2. -1000 OHMS OR MS-1,000,000 OHMS.
 3. ALL CAPACITOR VALUES ARE IN MICROGRAMS UNLESS
 FOLLOWED BY UP-MICROGRAMS.
 4. RESISTOR VALUES ARE IN OHMS UNLESS
 FOLLOWED BY K-1000 OHMS, M-1,000,000 OHMS,
 OR R-100 OHMS.
 5. TO OBTAIN COMPONENT PART NUMBER AFTER SYMBOL NUMBER
 TO THE RIGHT END OF UNIT NUMBER.

Figure 3-7. RT-224 Wiring Diagram

C9, and C10 balance the differences in gain between Q3 and Q4. The variable, R14 and C10, are adjusted to give the best doubled waveshape. Depending on the position of transmitter band switch S1, R28 and R19 supply the proper load for transformer T1.

d. Automatic Level Control. The automatic level control (ALC) protects the final amplifier transistors. A d-c voltage, proportional to the forward power, and a d-c voltage, proportional to the reflected power, as determined by the RF sampler circuitry, is coupled to the ALC circuit to limit the power output to protect the final amplifier transistors. The ALC also protects the transistors from shorts or opens in the antenna line. The d-c voltage proportional to the forward power is fed to the base of Q29 through CR29, while C18 performs as an RF bypass. The ALC forward power circuitry is designed (using C17 and CR29) to have a fast attack time and a slow decay time. The output from the emitter of Q29 is fed to the base of Q6 through R25. Q6 does not conduct unless Q5 is conducting or if the emitter potential exceeds the breakdown voltage of Zener diode CR4. Should the emitter potential of Q6 exceed this breakdown voltage, the transistor conducts. When Q6 is conducting the d-c bias current through CR5, CR6, and CR7 is reduced. This causes the a-c impedance presented by CR5 and CR6 to increase, thus attenuating to the RF signal. When the RF sampler module detects any reflected power, it feeds a d-c voltage proportional to that reflected power to the base of Q5 causing Q5 to conduct. This permits conduction of Q6, or increases conduction if Q6 is already conducting. Since the RF signal senses an increased impedance in series with the input of Q7, the RF signal power is again lowered, in effect adding attenuation to the RF signal.

e. Second Buffer Amplifier. The output of the ALC is fed to the emitter of second buffer amplifier Q7. The second buffer amplifier operates as a class A, common-base amplifier and isolates the loading effect of the attenuator circuit and the input to the class A amplifier stage. The collector is connected to transformer T2. The base is biased from the keyline by voltage divider R30 and R31. Capacitor C19 is the base bypass capacitor. R32 and C20 form a B+ decoupling network.

f. Class A Amplifier. The class A amplifier is used to amplify the RF signal output from the buffer stage to the 20-milliwatt level needed to drive the pre-driver stage. The output of the secondary winding of isolation transformer T2 is coupled through C21 to the emitter of Q8. The output of Q8 is fed to broadband push-pull transformer T3. The base is biased from the keyline by R36 and R37. Capacitor C22 is the base bypass capacitor.

g. Pre-Driver Amplifier. Transistors Q9 and Q10 connected in push-pull operation provide the 200-milliwatt level necessary to drive the driver amplifier. Transistors Q9 and Q10 are common-emitter amplifiers prebiased by R45. Diode CR8 reduces crossover distortion. Resistors R38 and R39 are used for d-c stability and also supply some emitter degeneration. The input to the bases of Q9 and Q10 is fed directly from the broadband push-pull transformer T3. The output from the collectors of Q9 and Q10 is fed directly to the push-pull transformer T1 in the driver amplifier stage.

3.6.2 Driver-Final Amplifier Assembly Detailed Description (Part of 1A4)

The driver-final amplifier consists of two stages operating push-pull to decrease harmonic output. The driver is a common-emitter, push-pull amplifier composed of transistors Q1 and Q2. The input to this stage is from broadband transformer T1. To reduce load variations with frequency, R1 and L1 act as a load for T1. To improve efficiency, R8 permits the stage to operate as class C amplifier. Degenerating feedback for Q1 and Q2 is provided by C7, C8, L2, L3, R2, and R11. The RF output is approximately 1 to 2 watts and is fed to broadband push-pull transformer T2.

The final amplifier stage is operated as a common-emitter push-pull amplifier consisting of transistors Q3 and Q4. The RF signal is fed to the bases of the two transistors from push-pull transformer T2. The secondary winding is center-tapped with R5 to ground permitting the final amplifier to operate class C increasing collector efficiency. Degenerative feedback across the base and collector of Q3 is achieved by a network consisting of R6, R9, and C2. Degenerative feedback across the base and collector of Q4 is achieved by a network of R7, R12, and C3. This reduces distortion and gain variations with frequency. The push-pull output of the final amplifier is fed directly to the primary winding of broadband transformer T3 which couples the balanced output of Q3 and Q4 through an unbalanced single-ended output to the RF sampler module.

3.6.3 Keyer Module Detailed Description (1A4A6)

The keyer module consists of the circuits necessary to operate the RT relay and includes side tone generator Q5. Generator Q5 is a unijunction transistor functioning as a relaxation oscillator and is excited in the hand key mode through CR2 and CR4. The output from the emitter of Q5 is coupled to the receiver audio amplifier through C2.

When the hand key on the front panel or on the handset is depressed or when the medium speed keyer is transmitting a character, a ground is applied to R4. Then R3 and R4 act as a voltage divider that decreases the positive bias on the base of Q2. Q2 conducts and in turn, causes Q3 and Q4 to conduct. Q4 supplies current to the RT relay and through external diode 1A4CR3 to the antenna relay. Capacitor C1 functions as a holding circuit to delay the RT relay from de-energizing when the hand key is operated. Through CR5, Q2 also supplies B+ to the low-level module.

When a microphone is used as the keying device, the keying circuit is energized by the push-to-talk switch on the microphone. This grounds R4 through a diode on the front panel. When a microphone is used, the base of Q5 is grounded through diode CR8 disabling the sidetone generator.

3.6.4 Modulator Module Detailed Description (1A4A5)

The modulator module with 1A4A8Q5 forms an audio amplifier that modulates the B+ voltage supplied to the driver-final amplifier. The output of the microphone is fed into emitter follower amplifier Q1. Transistors Q2, Q4 and Q5 form a direct coupled amplifier with d-c feedback from Q5 to Q2. A portion of the audio output of Q5 is rectified and fed to Q3. The output of Q3 is used to control the gain of Q2. The output of Q5 is capacitively coupled to the base of Q6. Transistor Q7 and the modulator transistor 1A4A8Q5 are direct-coupled amplifiers with d-c feedback to Q6.

Transistor Q1 is a conventional emitter follower amplifier. Q2 is a common-emitter amplifier with variable emitter degeneration. This degeneration is achieved by varying the current through CR1 to vary its dynamic or a-c impedance. Emitter bypass capacitor C5 is in series with CR1. As the impedance of CR1 varies, it changes the gain of Q2. The output of Q2 is directly coupled to Q4, a common-emitter amplifier, with some emitter degeneration obtained through R13. The output of Q4 is directly coupled to emitter follower Q5. A portion of the output of Q5 is coupled through C9 to CR4 to rectify it and change the bias on Q3. Transistor Q3 has a fixed bias supplied to its base through R17 from the Zener stabilized voltage divider composed of R14, CR3, R17, and R19. With no audio, maximum d-c current flows through Q3 and CR4 to minimize the dynamic impedance of CR1. As the audio signal increases, CR4 conducts and reduces the base voltage of Q3 which reduces the current through CR1, thus increasing its dynamic impedance. Transistors Q6, Q7, and 1A4A8Q5 form a d-c amplifier with negative feedback. The resistor divider R24 and R23 comprises the negative a-c feedback which in conjunction with R20 and R21 sets the d-c level at the collector of 1A4A8Q5. This level is adjusted in the modulator module test to 6 volts by adjusting the value of resistor R20. The audio signal from 1A4A5Q5 modulates the base of Q6 to change the base current of Q7, causing the collector voltage on 1A4A8Q5 to change. The collector voltage of 1A4A8Q5 is supplied to the driver-final amplifiers. This voltage change produces the AM modulation.

3.6.5 RF Sampler (1A4A2) Detailed Description

The RF sampler performs two functions. It provides the ALC circuitry with two d-c voltages proportional to the forward and the reflected power. It also provides a signal to the motor control to allow it to coarse tune the transmitter. The RF power input to the RF sampler is from final amplifier broadband transformer T3. The unaffected RF power is fed directly to the antenna matching network. Separate sensing devices are used for the forward and the reflected powers.

a. Reflected Power Circuitry. The reflected power sensor compares the out-of-phase voltage and current. Current transformer T1 samples the signal current and capacitive voltage divider (C2, C3, C4, and C5) samples the signal voltage. Diode CR1 sums the out-of-phase components and generates a d-c voltage proportional to the reflected forward power. Filter network L2, R1, C1, and L1 removes all RF voltage from the detected d-c voltage. The resultant d-c voltage is coupled directly to the ALC circuitry in the low-level module.

b. Forward Power Circuitry. The forward sensor is similar to the reflected sensor except that the forward sensor compares the in-phase voltage and current. Current transformer T2 samples the current, and capacitive voltage divider C6, C7, and C8 samples the RF signal voltage. CR2 sums the in-phase components and develops a d-c voltage proportional to the forward power. Filter network L3, C9, R6, C10, and L4 filters this d-c voltage to remove all the RF voltage. The resulting d-c voltage is coupled to the ALC circuitry in the low-level module. Variable resistor R10 adjusts the loop gain and consequently sets the output signal, which is normally 20 watts.

c. Harmonic Filter Network. Three harmonic filters are incorporated in the RF sampler module to remove harmonics that might otherwise generate erroneous signals in the reflected ALC line to the motor control circuits. The highest harmonic filter, attenuation above 24 MHz, made up of L5, C11, R7, R8, R9 and R10, is permanently connected across the RF input line. When operating in 2 to 12 MHz range, relay K1 connects the low harmonic filters (L6, C12, R11, R12, R13, R14) and (L7, C13, R15, R16, R17, R18) across the RF input line K1 is energized by the transmitter bandswitch.

3.6.6 Antenna Matching Network Detailed Description (1A4A8)

The antenna matching network matches the impedance of the antenna to the proper load line impedance for the transmitter. The output of the RF sampler is fed directly to the matching network at variable inductor L1. The matching network is a T-network. Variable inductor L1 is used in the input arm with variable capacitor C1 as the shunt element. A small inductor 1A4A1L1 is in the output series arm. The variable inductor and capacitor are geared together and are driven by a motor during the coarse tune cycle of normal operation. The fine tuning or peaking is accomplished with the FINE TUNE control on the front panel. If necessary this control can be used for the entire tuning procedure, but it requires approximately six turns of the control to obtain one turn of the variable inductor. The RF power output of the matching network is fed to the antenna through the tuning indicator module and antenna relay.

3.6.7 Antenna Tuning Module (1A4A1) Detailed Description

The antenna tuning module drives the TUNE/VOLTS meter located on the front panel. In the fine tune mode, the fine tune control is adjusted to obtain a peak deflection on the meter. Transformer T1 senses the RF current output of the antenna matching network, and voltage divider R5, R6, R7, R8, and R9 senses the RF voltage. The RF current sample is rectified by voltage doubler CR1 and CR2. The rectified voltage is filtered by C2 and is fed to R2. The RF voltage sample from the voltage divider is rectified by CR4. The resultant d-c voltage is filtered by C3 and fed to R10. The voltage across the series combination of R2 and R10 is the sum of the rectified current sample from T1 and the rectified voltage sample from voltage divider R5, R6, R7, R8, and R9. This voltage drives the TUNE/VOLTS meter. The RF power through the antenna tuning module is fed to the antenna relay which is energized when the transmitter is keyed and the RF power is fed to the antenna.

3.6.8 Motor Control Circuitry Detailed Description

The motor control circuitry coarse tunes the antenna matching network module 1A4A8 to eliminate most of the hand tuning. The motor control circuitry is on two printed circuit boards, 1A4A3 and 1A4A4. It will be necessary to describe parts of the circuitry on both boards simultaneously.

a. Motor Control Module No. 2, 1A4A4. When the transmitter power is turned on and the transmitter tune knob, AUTO-PULL, is actuated, a positive 12 volts is applied to R18. A positive d-c spike is sensed at the base of Q3, causing it to conduct. The collector voltage of Q3 is coupled to pin 10 of

flip-flops Z1 and Z2 to cause the output pin 8 to latch in the high state. Since the cathodes of CR1 and CR3 are in a high state, current is shunted through CR2 and CR4 causing Q4 and Q5 to conduct. The collector of Q4 is connected to the coil of the tune relay and the collector of Q5 is connected to the coil of the motor relay. When Q4 and Q5 are saturated, they appear as a ground and the relays energize. Resistors R9 and R13 tend to stabilize the circuits. When Q5 is saturated, Q6 is held at cutoff, as is Q7. While the motor relay is energized, the antenna matching network module is being driven toward maximum inductance and the transmitter circuits do not operate. When maximum inductance is reached a microswitch in the antenna matching network energizes causing Z2 to latch up, so that pin 8 is in a low state. Thus, Q5 is cut off, de-energizing the motor relay and reversing the direction of the motor to drive the antenna matching network toward minimum inductance. When Q5 is cut off, Q6 will conduct, causing Q7 to saturate. The output at the collector of Q7 is approximately 12 volts and is fed to the keyer module 1A4A6 which keys the low-level module 1A4A7. D-c voltage for the driver-final assembly is applied through the RT relay which is keyed by the tune relay. When both the low-level module and the driver final assembly have B+ applied, the RF power output is sampled in the RF sampler module 1A4A2. The voltage proportional to the reflected power is coupled to the motor control circuit board module 1A4A3.

While the motor is driving the inductor toward minimum inductance, the system is searching for a tuning point. If this point is not found, the inductor eventually will reach minimum inductance. The minimum inductance switch is depressed causing pin 12 on Z2 to go low. This sets pin 8 high and pin 6 low. The motor is turned around and RF is removed from the driver final section. The low voltage on pin 6 is fed to pin 13 on Z1. This low voltage keeps pin 8 high and the tune relay remains actuated. The motor continues to cycle giving the operator a non-tune indication.

b. Motor Control Module No. 1, 1A4A3. The voltage representing reflected power is coupled through C3 and RF choke L1 to the base of Q1. The base of Q1 is biased at 0.5 volt below the B+. When Q1 conducts, the inverted output is fed to the base of emitter follower Q2. Diode CR3 and capacitor C4 filter the pulsating voltage caused by the lack of a discharge path for C4. The voltage at the base of Q2 is then a voltage representing the peaks of the pulsating voltage. The output of Q3 is capacitively coupled from the collector through C7 to pin 2 of operational amplifier Z1. R7 functions as a swamping resistor. The operational amplifier does not respond to a negative-going voltage, but when the antenna matching network is driven through the correct tune point, the voltage, representing reflected power at the input to the operational amplifier, goes in a positive direction. With the positive-going voltage present at the input, the output of the operational amplifier drops, causing Q1 on circuit board 1A4A4, to saturate. The output at the collector of 1A4A4Q1 is supplied to the base of 1A4A4Q2 causing it to saturate. When 1A4A4Q2 is saturated, the collector voltage coupled to pin 4 of flip-flop 1A4A2Z1 is low, causing the voltage at pin 8 of 1A4A4Z1 to be low, causing 1A4A4Q4 to cut off. Thus the tune relay is de-energized and the drive motor is stopped.

3.7 Power Supply Circuitry (Part of 1A1)

The normal power supply for the radio set is a sealed, rechargeable, nickel-cadmium battery, capable of delivering approximately 12 volts at 6 amperes maximum. An external power supply with the same capabilities as the battery can be connected to the external power connector on the front panel at 1A1J5. The battery is connected to the radio set through connector 1A1P2. The battery voltage is fed to metering circuitry, to the front panel light switch, to pin 4 of the RT relay 1A1A3K1, and to POWER switch 1A1S2A where it is distributed according to the switch position. When an external power supply is connected to POWER connector 1A1J5, power source relay 1A1A3K2 is energized, disconnecting the battery. Diodes 1A1CR8 and 1A1CR9 are used for reverse polarity protection when using an external power supply. When the power source relay is energized, the external power supply voltage is distributed in the same manner as the battery voltage.

3.7.1 Battery Protection Circuit

The principle function of the battery protection circuit is to disconnect the internal battery from the radio when the battery voltage drops below 10 volts. Its secondary function is to connect an external supply to the radio electrically when the supply is connected to the front panel. When 1A1S2 is in the RCVR or the

RCVR/XMTR position the battery voltage is present at pin 6 of the latching relay 1A1A3K2. When the RESET button 1A1S1 is pushed, the coil between pins 3 and 4 of 1A1A3K2 is energized, placing the relay in the internal battery position. Thus 1A1A3K2-5 and 1A1A3K2-10 are connected, and 1A1A3K2-1 and 1A1A3K2-6 are connected. The battery voltage is then present at the junction of 1A1A1R3 and 1A1A1R2. Zener diode CR4 establishes the reference voltage for the emitter of Q1. The base voltage of Q1 is a voltage proportional to the battery voltage. As long as the battery voltage is high enough, Q1 is cut off. If the battery voltage drops below a certain value, the base voltage of Q1 drops low, turning Q1 on. This raises the base voltage of Q2, thus turning Q2 on. When Q2 is saturated, pin 8 of 1A1A3K2 is held low. Pin 8 is tied to one end of a coil. At the other end of the coil, pin 7 is tied to B+ through diode 1A1A3CR2. This energizes the relay to the external supply position. The battery is disconnected not only from the radio set but also from the battery protection circuit itself, since pins 6 and 1 of 1A1A3K2 are no longer connected. When an external supply is connected to the front panel connector, it supplies current to the base of Q2 through R4 and CR5. This has the same effect as a low battery because Q2 is saturated. The relay is thrown to the external power position.

3.7.2 Battery Charging Circuit Description (Part of 1A1A3)

The battery charging circuit consists of two diodes connected between the battery and the external charging source. A d-c voltage of 17 volts from an external source is applied to pin C of POWER connector 1A1J5 when the POWER switch is in any position. This causes current to flow through 1A1CR1 and 1A1CR3. The battery is fully charged after charging for approximately 14 hours. The diodes prevent the battery from discharging when the charging circuit is cut off or disconnected.

CHAPTER 4

ALIGNMENT AND ADJUSTMENT

4.1 Scope

This section is divided into two primary groups: the receiver and the transmitter. Each primary group is broken down further to provide adjustment procedures of circuits within the primary group. Figures 3-1 through 3-7 should be referenced for electrical location of the test points and adjustments.

4.2 TAR-224 Radio Set Electrical Alignment

Align Radio Receiver RR-224 as described in paragraphs 4.3.1 through 4.3.5. Adjust Radio Transmitter RT-224 as described in paragraph 4.4.

4.3 RR-224 Radio Receiver Electrical Alignment Procedure

4.3.1 Test Equipment:

Oscilloscope	Tektronix 545A or equivalent
Frequency Counter	HP 524D with HP 525A converter, or equivalent
Signal Generator	HP 606A or equivalent
AC VTVM	HP 400C or equivalent
DC VTVM	HP 410B or equivalent
Power Supply	Power Design 4005 or equivalent
3db, 50 ohms pad	Microlab B/FXR-AD-03N or equivalent

4.3.2 Local Oscillator Alignment (Figure 4-1)

a. Set the receiver controls as follows:

MODE	RCVR
RCVR MODE	AM
BAND	4
RCVR CAL	Center of range

b. Connect a signal generator (HP 606A or equivalent), modulated 30 percent at 1 KHz through the 3 db pad to the antenna posts on the front panel of the radio set. Observe ground and antenna correlation. Terminate the PHONE jack (pins A and B) with a 500 ohm load, an audio VTVM (HP 400C, or equivalent), and an oscilloscope (Tektronix 545A, or equivalent). Use the frequency counter (HP 524D with HP 525A plug in, or equivalent), to set the signal generator to the desired dial setting on the receiver.

c. Tune to 16.0 MHz, the low end of band 4. Adjust 1A3A4T1 (figure 5-3) for maximum audio output.

d. Tune to 22 MHz at the high end of band 4. Adjust trimmer capacitor 1A3A4C1 (figure 5-9) for maximum audio output.

e. Alternately repeat steps c and d until no further adjustment is necessary.

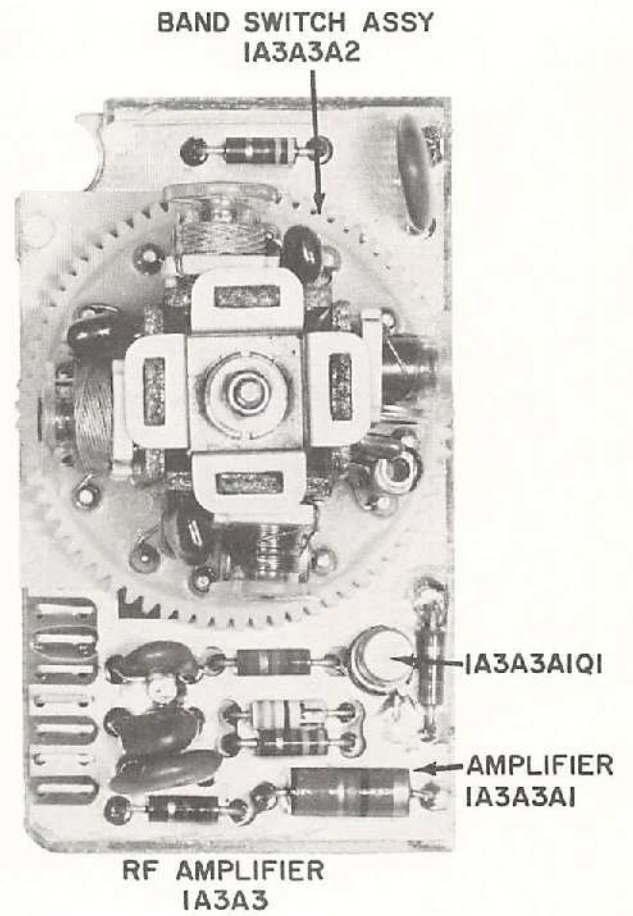
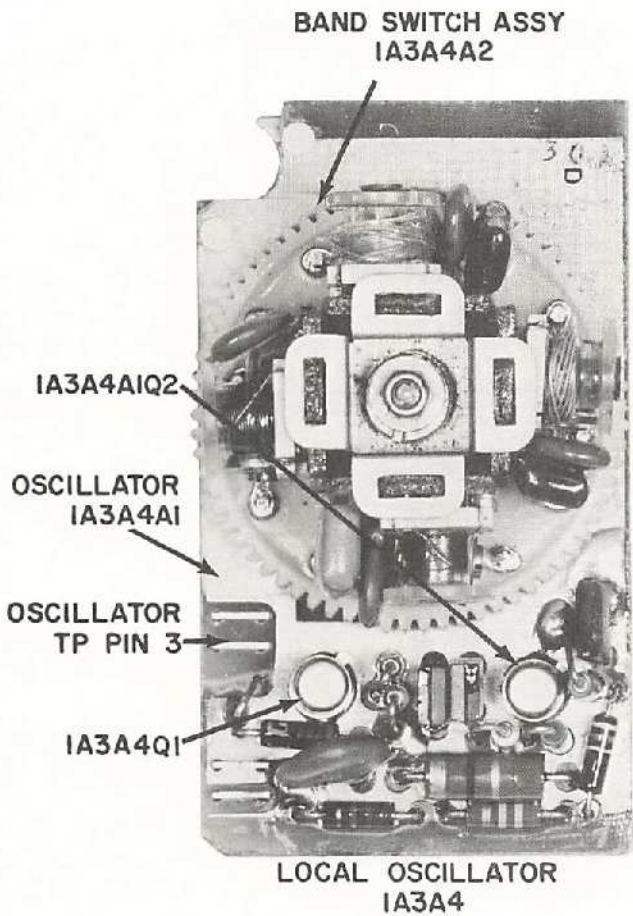

Figure 4-1. RF Amplifier and Local Oscillator

f. Repeat steps c, d and e on bands 3, 2, and 1. The tunable capacitors and inductors as well as the adjustment frequencies, are listed in table 4-1. Adjust the capacitors and inductors at the high and low ends of each band respectively.

TABLE 4-1. LOCAL OSCILLATOR ADJUSTMENT

Band	Trimmer Capacitor	Inductor	Frequencies - - MHz			
			High End		Low End	
			Dial	LO	Dial	LO
1	C12	T4	3.500	3.955	2.200	2.655
2	C9	T3	6.900	7.355	3.700	4.155
3	C4	T2	12.893	13.348	6.893	7.348
4	C1	T1	22.000	22.455	16.000	16.455

NOTE: Figures 5-3 and 5-9 show table 4-1 components location.

4.3.3 RF Amplifier Alignment (Figure 4-1, 4-2)

a. Set the receiver controls as follows:

MODE	RCVR
RCVR MODE	AM
RF GAIN	Maximum clockwise

b. Connect a signal generator (HP 606A or equivalent), modulated 30 percent at 1 kHz, through the 3 db pad to the antenna posts on the front panel of the radio set. Observe ground and antenna correlation. Terminate the PHONE jack (pins A and B) with a 500 ohm load, an audio VTVM (HP 400C, or equivalent), and an oscilloscope (Tektronix 545A, or equivalent).

c. Retune the receiver and signal generator to the low end of the band. Adjust the applicable inductors in the antenna section and RF section until maximum output is obtained, reducing the signal generator output to maintain an undistorted audio output (figures 5-3 and 5-9).

d. Set the BAND selector to the desired band and tune the receiver to the high end of the band. Tune the signal generator to the receiver frequency and adjust the signal generator output until an audio output of nominally 1-milliwatt is obtained. Reduce the AF GAIN as necessary to obtain an undistorted audio output. Adjust the applicable trimmer capacitors in the antenna section and RF section until maximum audio output is obtained (figures 5-3 and 5-9).

e. Alternately repeat steps c and d until no further increase in the output is obtainable at either end of the band by tuning. Do not reduce the signal generator output below 3 microvolts on the 10 microvolt scale. The tunable capacitors and inductors, as well as the adjustment frequencies, are listed in table 4-2. Adjust the trimmer capacitors and inductors at the high and low ends, respectively, of the bands (figures 5-3 and 5-9).

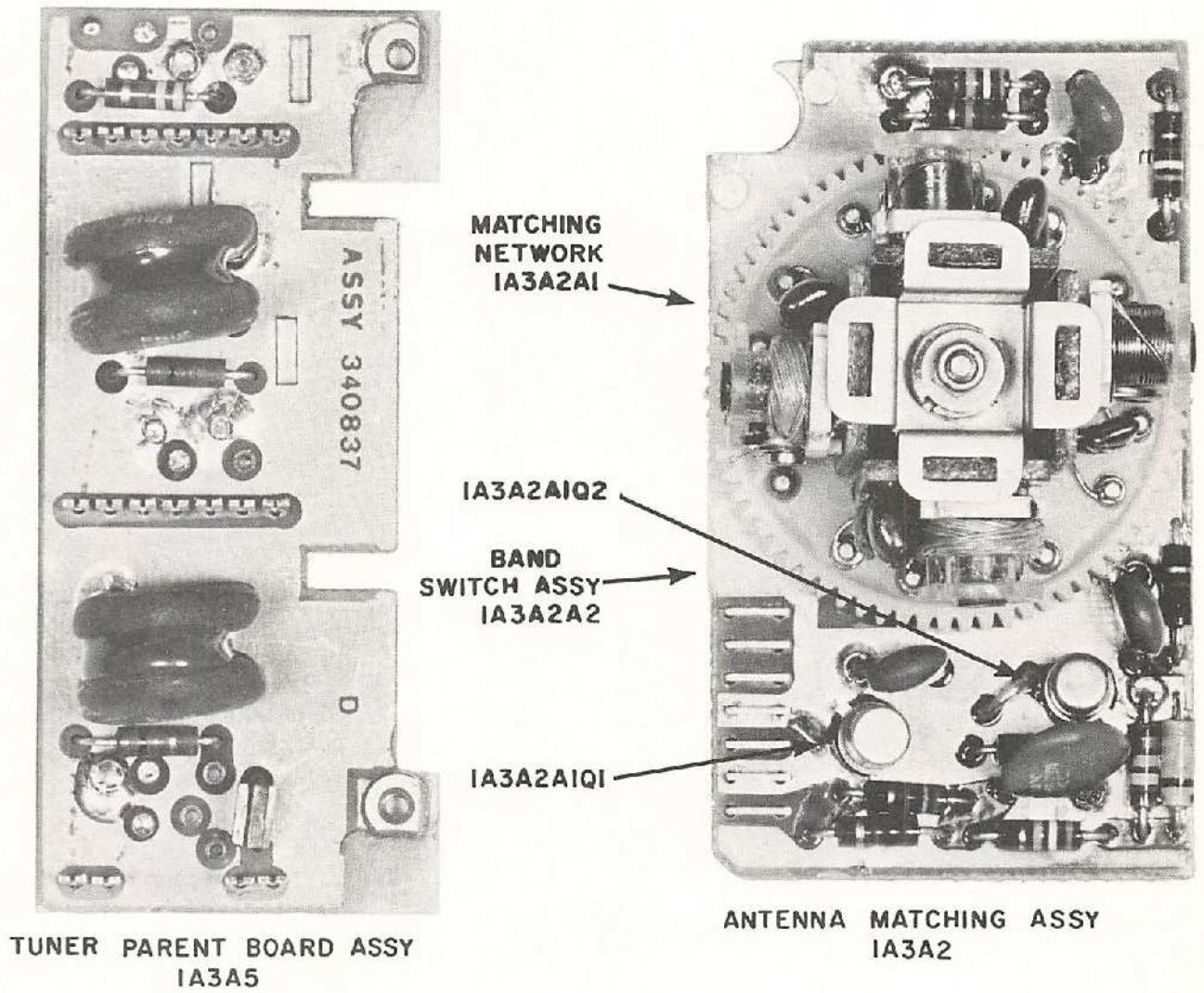

Figure 4-2. Antenna Matching Network and Parent Board

TABLE 4-2. RF AMPLIFIER ADJUSTMENT

Band	Trimmer Capacitors		Inductors		Frequency -- MHz	
	Ant.	RF	Ant.	RF	High End	Low End
1	C13	C14	T4	T4	3.5	2.2
2	C9	C10	T3	T3	6.0	3.7
3	C6	C6	T2	T2	12.893	6.893
4	C2	C2	T1	T1	22.0	16.0

NOTE: Figures 5-3 and 5-9 shows table 4-2 component locations.

4.3.4 BFO Alignment

- a. Set the receiver controls as follows:

MODE	RCVR
RCVR MODE	CW
BFO	0

b. Connect an oscilloscope (Tektronix 545 or equivalent) to E1 (figure 4-3) on the BFO board 1A3A6A2. Connect a frequency counter (HP 524D or equivalent) to the vertical output of the oscilloscope.

c. Adjust 1A3A6A2L1 (figure 4-3) until the BFO frequency range controlled by the front panel BFO potentiometer, is symmetrically located with respect to 455 kHz.

d. Set the RCVR MODE switch to CAL position with the dial to a noncalibration frequency that is not a 0.5 MHz harmonic. Adjust 1A3A1R4 (figure 4-4) for a BFO frequency of 455 kHz.

4.3.5 IF Amplifier Alignment

a. To adjust the IF amplifier, inductors 1A3A7L1, L2, and L3 are adjusted for maximum output from the IF amplifier. This adjustment normally is made prior to installation of the IF amplifier in the receiver.

b. To adjust the IF amplifier while it is mounted in the receiver, tune the receiver in the AM mode to a 2 MHz signal from a signal generator, 30 percent modulated at 1 kHz.

c. Turn the RF GAIN control 1A1R5 (figure 2-1) on the front panel maximum clockwise. Decrease the signal generator output until a 1 mw audio output is obtained.

d. Adjust inductors 1A3A7L1, L2, and L3 for maximum output (figure 6-1). Reduce the signal generator output, if necessary, to maintain an undistorted audio output of 1 mw.

4.4 RT-224 Radio Transmitter Electrical Adjustment

Radio transmitter RT-224 adjustments are made as described in paragraph 4.4.1.

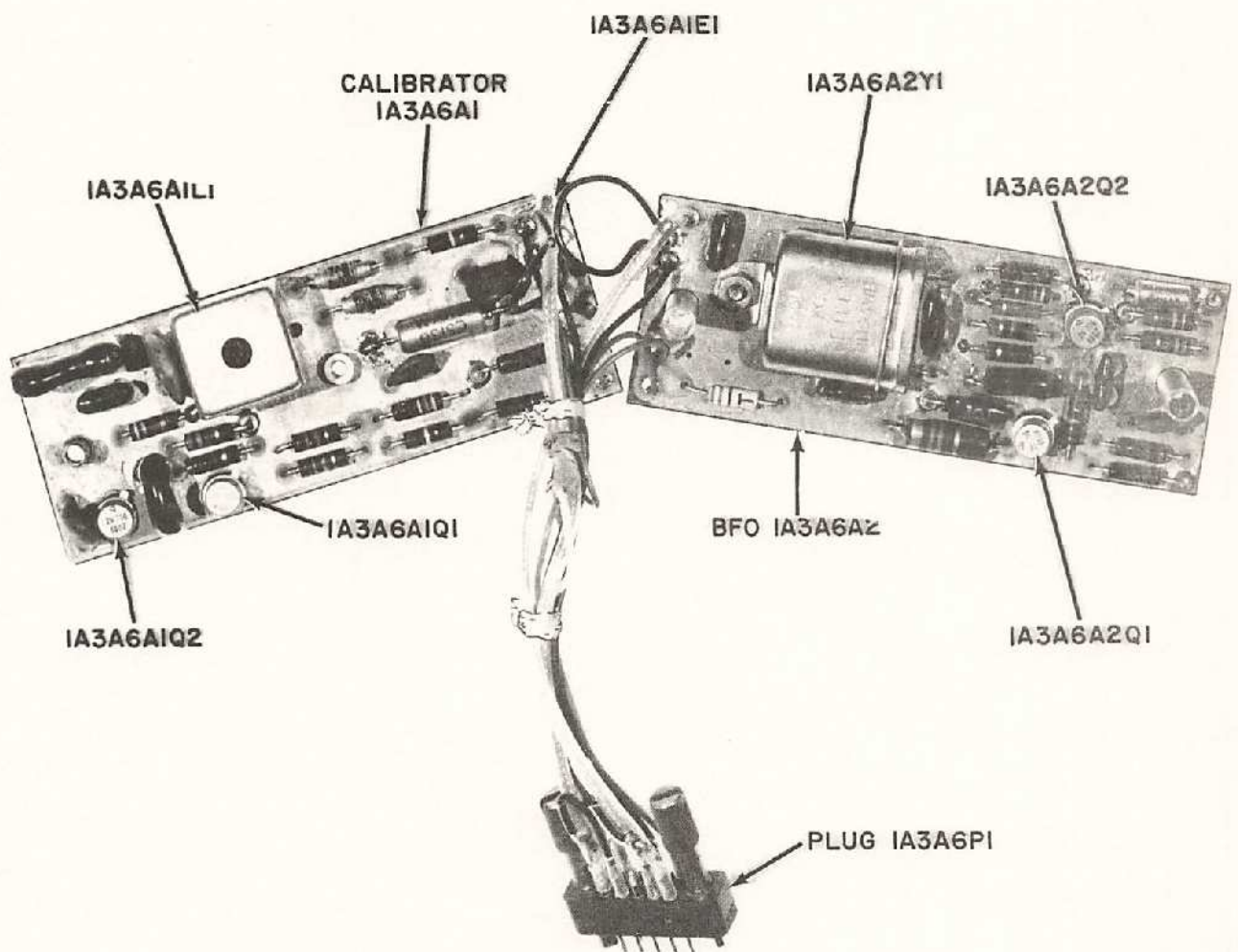

Figure 4-3. Calibrator and BFO

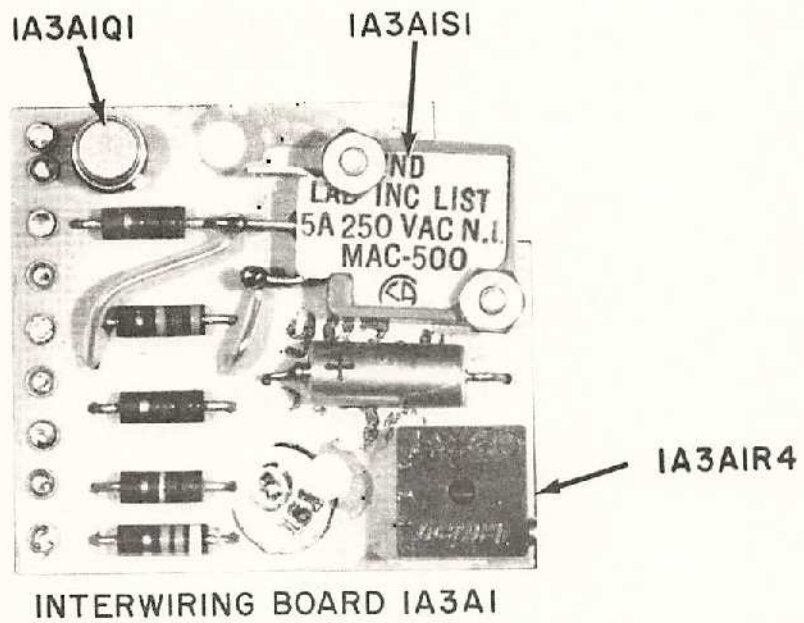

Figure 4-4. Circuit Board Assembly

4.4.1 Transmitter Adjustments

4.4.1.1 Low Level Module Adjustments (1A4A7)

a. Test Equipment

Power Supply	Hewlett-Packard, Model 721
Power Supply	Harrison Lab, Model 810B
Oscilloscope	Tektronix, Model 561
Dual-Trace Pre-Amplifier	Tektronix, Type 3576

b. Initial Instructions

- (1) Remove transmitter from front panel (paragraph 5.13). Solder a crystal socket to the low level module input coaxial cable.
- (2) Connect plug 1A4P1 to jack 1A1J3 (figure 5-15).
- (3) Connect a ground strap from front panel to the transmitter chassis.
- (4) Connect +8 vdc from power supply, Hewlett-Packard model 721, to the Forward Line (figure 5-16).
- (5) Connect 12 vdc power supply, Harrison Lab model 810B, to the external POWER input plug on front panel.
- (6) Connect oscilloscope, A or B input, to cathode of 1A4A7CR3 (figure 5-16).
- (7) Insert a 2-MHz crystal in the low level module test crystal socket. Check for prompt oscillation with the transmitter keyed. If prompt oscillation is not observed on the scope, adjust capacitor 1A4A7C2 until a clean trace is seen on the scope.
- (8) With the front panel key depressed, check for oscillation between 2.5 and 3.2 volts peak-to-peak presentation on the scope.

NOTE

If the amplitude is out of this range, the value of resistor 1A4A7R2 must be changed between 3.3K and 4.7K to obtain the waveform within limits.

- (9) Connect the oscilloscope, A or B input, to the collector of 1A4A7Q4 (figure 5-16).
- (10) Connect a 6-MHz crystal to the low-level input (figure 5-16).
- (11) Set transmitter BAND switch to 12-24 MHz position.
- (12) Adjust 1A4A7R14 (figure 5-16) for equal double peaks with the key on front panel depressed.

4.4.1.2 RF Sampler Module Adjustments

a. Test Equipment

Differential Voltmeter	John Fluke Model 801
Signal Generator	Hewlett-Packard Model 606A
Transmitter	Johnson Viking II-CDC
VTVM	Hewlett-Packard Model 410B

b. Initial Instructions

- (1) Adjust 1A4A2R19 for 20K ohms as measured from pin 5 on the board to ground (figure 4-5).

NOTE

The positive lead on the meter must be connected to point B for this adjustment.

c. Reflected Power Detector Adjustment

- (1) Connect the test equipment to the RF sampler module (figure 4-6).
- (2) Tune transmitter to 24 MHz.
- (3) Increase power out of transmitter until 20 watts is measured across the 35 ohm load.

NOTE

20 watts corresponds to 26.4 volts RMS as measured with the VTVM.

- (4) Adjust variable capacitor 1A4A2C3 for a minimum d-c voltage as measured from pin 2 to ground (figure 4-5).

d. Forward Power Detector Adjustment

- (1) Connect the test equipment as in step c(1) except switch the RF input and the RF output on RF Sampler module and change Fluke meter from pin 2 to pin 5.
- (2) Tune transmitter to 24 MHz.
- (3) Increase power out of transmitter until 20 watts is measured across the 35 ohm load.

NOTE

20 watts corresponds to 26.4 volts RMS as measured with the VTVM.

- (4) Adjust variable capacitor 1A4A2C7 for minimum d-c voltage as measured from pin 5 and ground (figure 4-5).

e. Repeat step c.

Measure and record minimum d-c voltage.

- (1) Pin 2 to ground, 700 mv or less.
- (2) Pin 5 to ground, 6 volts minimum.

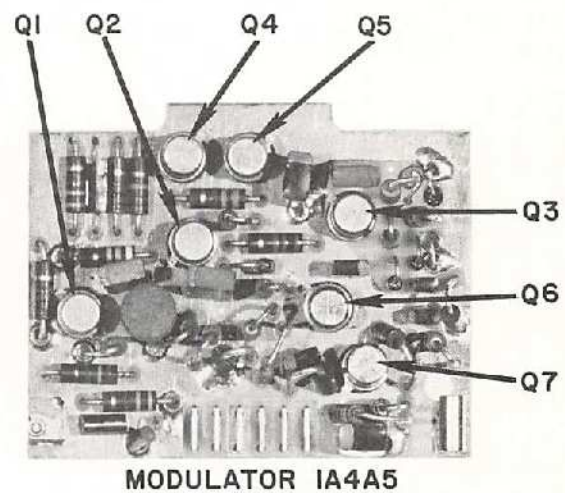
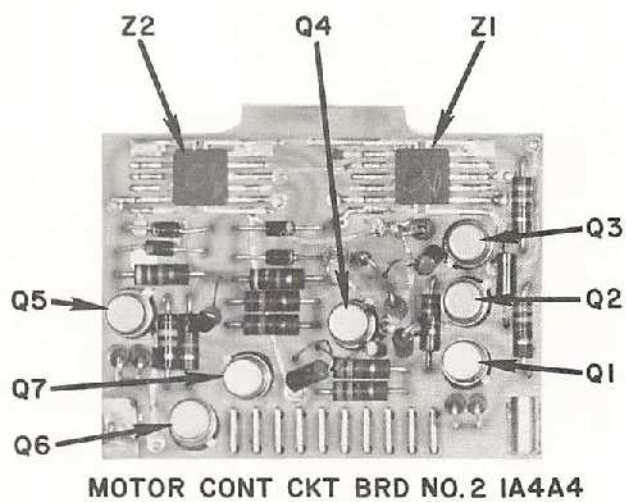
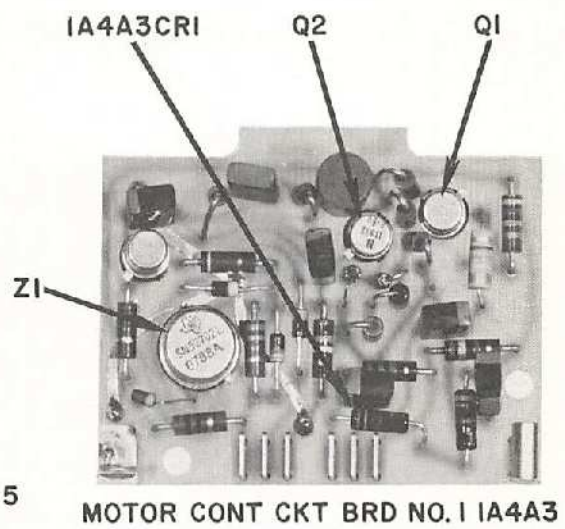
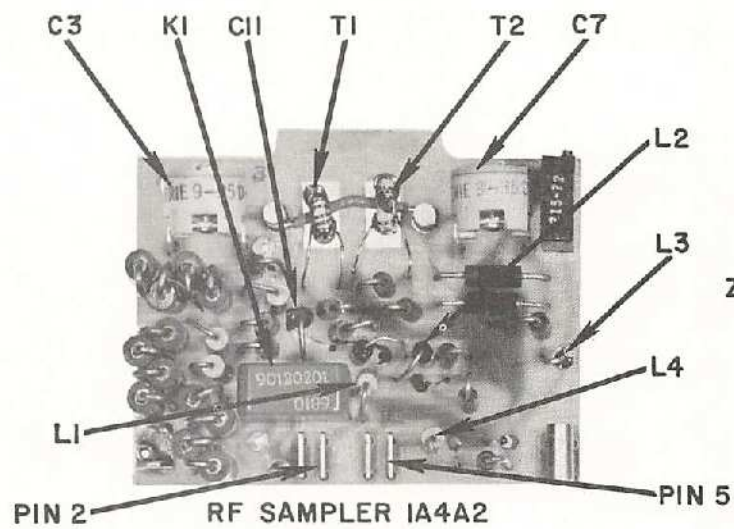

Figure 4-5. Modulator, RF Sampler and Motor Control Boards No. 1 and No. 2

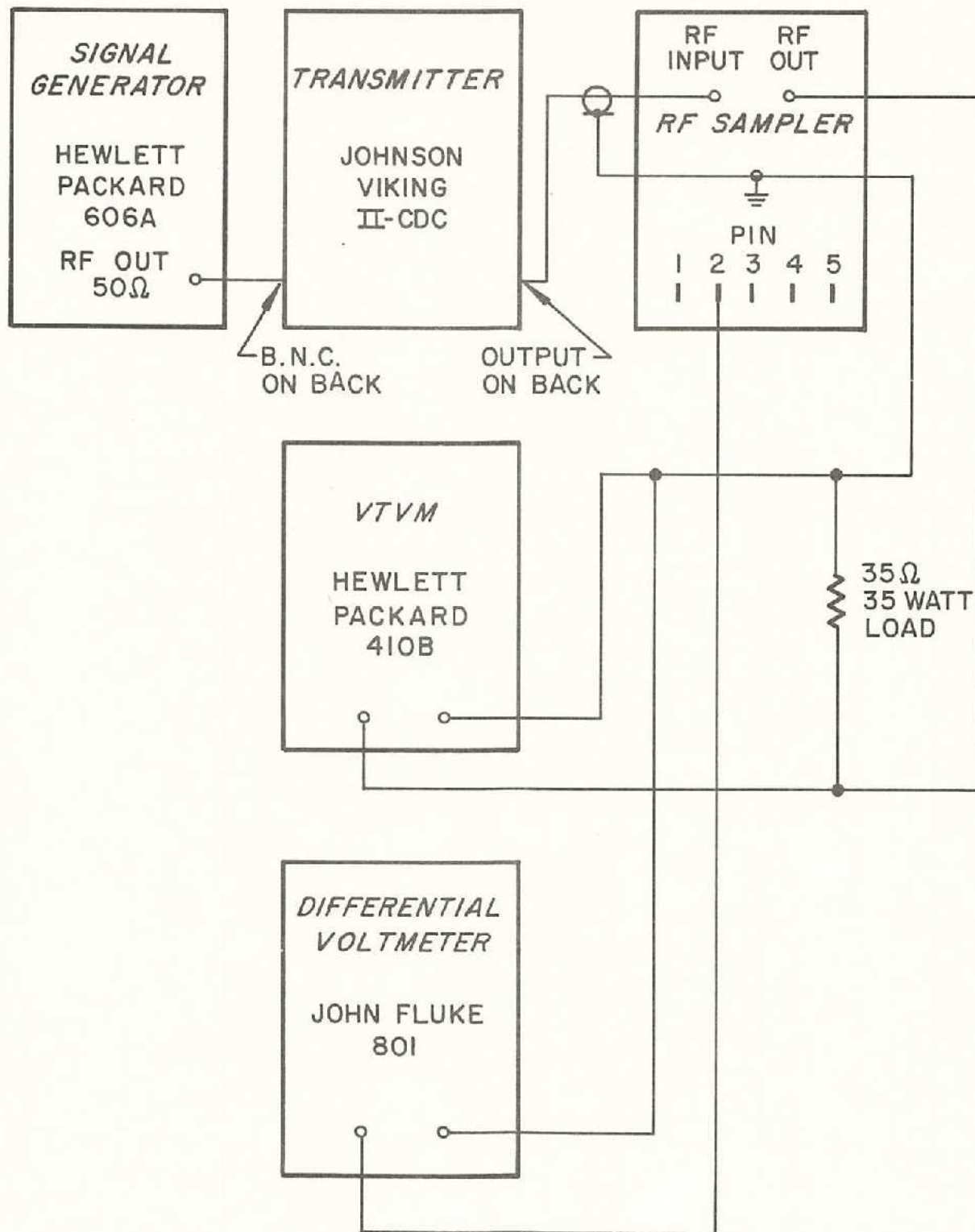

Figure 4-6. RF Sampler Test Equipment Set-Up

f. Repeat step d.

Measure and record minimum d-c voltage.

(1) Pin 5 to ground, 1000 mv or less.

(2) Pin 2 to ground, 5.4 volts minimum.

g. Repeat step c.

Tune transmitter to 2 MHz. Measure and record minimum d-c voltage.

(1) Pin 2 to ground, 700 mv or less.

(2) Pin 5 to ground, 6 volts minimum.

h. Repeat step d.

Tune transmitter to 2 MHz. Measure and record minimum d-c voltage.

(1) Pin 5 to ground, 700 mv.

(2) Pin 2 to ground, 5.7 volts minimum.

CHAPTER 5

RADIO SET TAR-224 DISASSEMBLY

5.1 Scope

This chapter provides procedures for the location, removal, and replacement of TAR-224 major units, subassemblies, and components. The removal and replacement of component parts that do not require any special procedures will not be detailed.

5.2 Battery Removal and Replacement (figures 5-1 and 5-2).

a. Battery Removal

- (1) Position the radio set with the battery access cover facing upward and with the front panel toward you.
- (2) Open the hinged access cover by lifting latch.
- (3) Raise the battery lifting handles and lift the battery out of its case.

CAUTION

The battery must be lifted evenly from the case. If the battery is tilted upon removal, damage to the battery connector could result.

b. Battery Replacement

- (1) Grasp the battery by the handles and lower it evenly into the case and mate the battery connectors.

NOTE

A slight push on the connector end of the battery may be required to completely mate the connector.

- (2) Depress the POWER TEST switch. A correct reading on the TUNE/VOLTS meter will indicate the battery is installed properly.
- (3) Ensure the O-ring on the cover is in place and close the battery access cover.

5.3. Case Removal and Replacement 1A2

a. Case Removal

- (1) Position the radio set with the front panel up and battery compartment toward you (figures 5-1 and 5-2).
- (2) Remove 10 captive allen-head screws around the outside of the front panel.

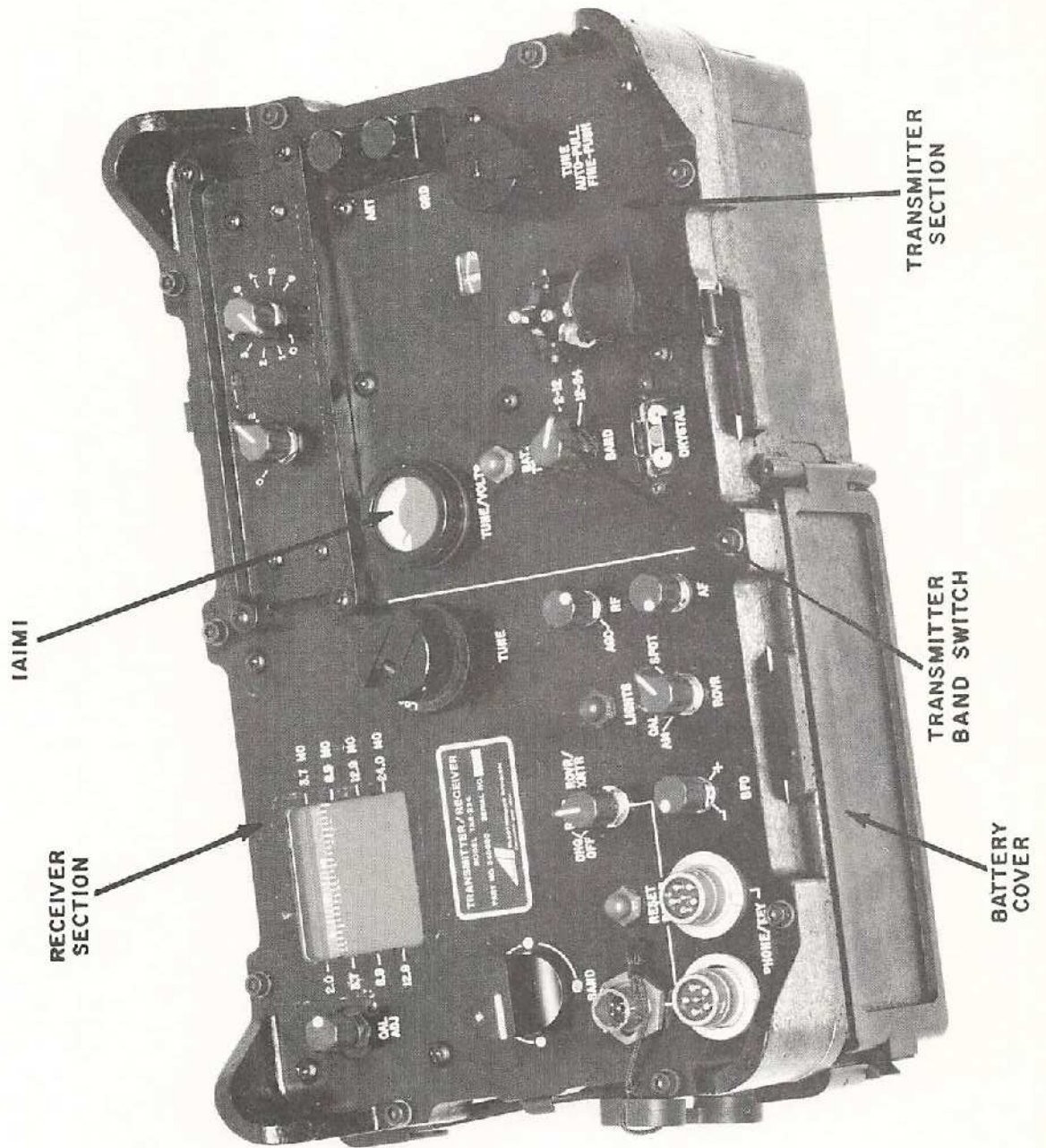
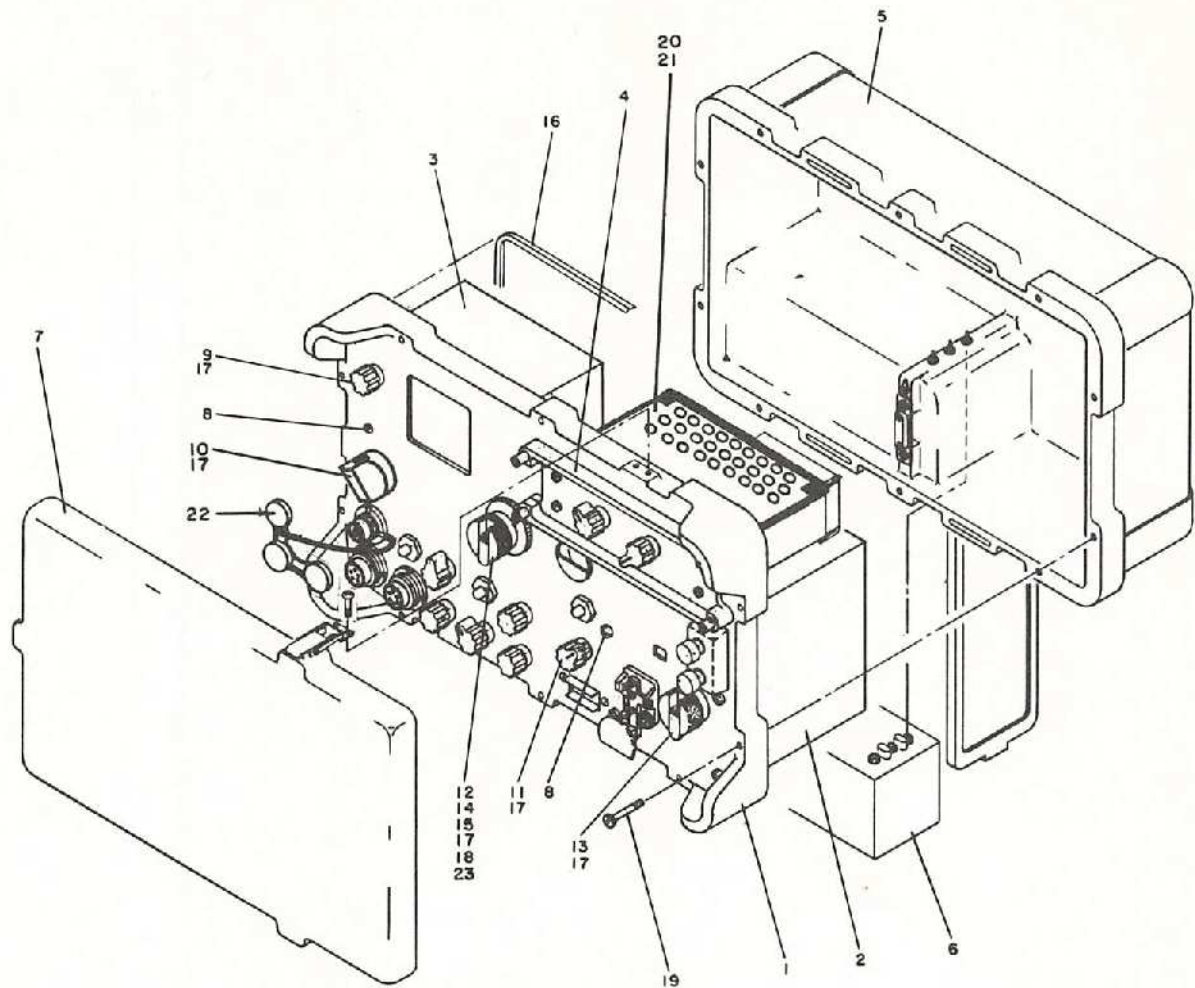

Figure 5-1. Transceiver TAR-224



ITEM NO.	PART NO.	DESCRIPTION
1	340603-1	FRONT PANEL ASSEMBLY
2	340602	TRANSMITTER ASSEMBLY
3	340601	RECEIVER ASSEMBLY
4	340561	XTAL SEL. ASSEMBLY
5	340947	CASE ASSEMBLY
6	340583	BATTERY
7	340881	COVER ASSEMBLY
8	340772-3	SCREW, SEALING
9	340594	KNOB
10	340612	KNOB
11	340593	KNOB, POINTER
12	377000	KNOB ASSY
13	340576-2	KNOB
14	377002	LOCKWHEEL
15	340743	BUSHING
16	J57-1LVF2HS100E	GASKET
17	MS51963-9	SET SCREW
18	5-102-PS1-30-5	"O" RING
19	J02-M0625E375HC	CAPTIVE SCREW
20	340423	DESSICANT
21	340761	HOLDER
22	340191	COVER, PROTECTIVE
23	377003	LOCKSCREW

Figure 5-2. TAR-224 Exploded View

- (3) While holding the case to the front panel, turn the radio set over (end over end) with the CS-224 section of the front panel away from you and to your left (figure 5-3).
- (4) Lift case up and away from front panel.

b. Case Replacement

- (1) Position the front panel as it was in the case removal procedure, paragraph 5.3a. Be sure that the O-ring is properly installed in the front panel.
- (2) Lift the case up and position it over the rear of the front panel; carefully push the two together. Be sure that the battery connectors are engaged (figure 5-3).
- (3) While holding the case and front panel together, turn the radio set over and rest it on its case.
- (4) Tighten the 10 captive screws evenly, securing the case to the front panel (figures 5-1 and 5-2).

5.4 RR-224 Receiver Removal and Replacement

a. RR-224 Removal

- (1) Remove the CAL ADJ, receiver BAND, and receiver TUNE knobs from the front panel (figures 5-1 and 5-2).
- (2) Remove the receiver TUNE knob locking wheel by turning it counterclockwise; tilt the radio set up on edge and tap it lightly so that the brass bushing around the TUNE knob shaft falls out.
- (3) Remove the radio set case as detailed in paragraph 5.3a.
- (4) Remove four screws holding the receiver to the front panel.
- (5) Remove the receiver chassis by lifting it straight up and away from the front panel (figure 5-1).

b. RR-224 Replacement

- (1) Replace the receiver chassis by putting it straight down on the front panel (figure 5-2).
- (2) Replace four screws that hold the receiver to the front panel.
- (3) Replace the radio set case as detailed in paragraph 5.3b.
- (4) Replace the brass bushing with the slotted ends going into the hole first, then insert the TUNE knob locking wheel.
- (5) Replace the CAL ADJ TUNE and BAND knobs on the front panel. Do not install tune knob too low on the shaft or lock the knob when too low on the shaft. These conditions will cause damage to the bearings of the capacitor.

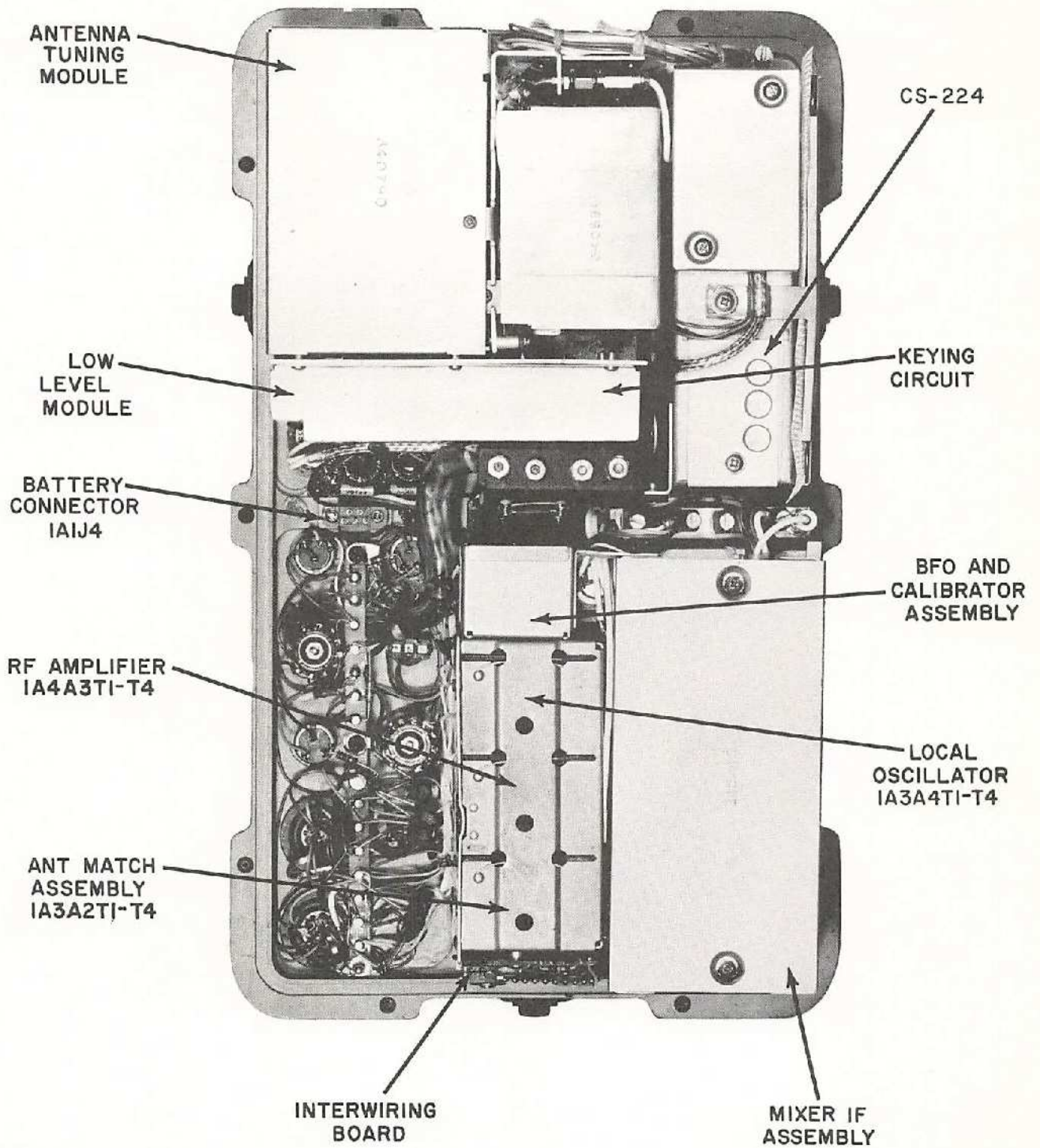

Figure 5-3. TAR-224 Module Location (bottom view)

5.5 IF Amplifier Removal and Replacement 1A3A7

a. 1A3A7 Module Removal

- (1) Remove two common screws securing the cover to the module can and remove the cover (figures 5-3 and 5-4).
- (2) Remove four mounting screws securing the printed circuit board to its can (figures 5-4 and 5-5).
- (3) Disconnect the coaxial cable 1A3A7P2 alongside the module plug (figure 5-5).
- (4) Disconnect the module plug 1A3A7P1 by loosening the two connector screws (figure 5-5).

CAUTION

The screws must be loosened evenly to prevent damage to the connector.

- (5) Lift the module straight up and away from the can with as little strain as possible to the cable and plug.

b. 1A3A7 Module Replacement

- (1) Place the module in the can while guiding the rubber grommet which is around the cable into the slot. Be careful not to put too much strain on the cable and plug (figure 5-5).
- (2) Tighten the screws securing the connector and reconnect the coaxial cable (figure 5-5).
- (3) Replace the four mounting screws securing the printed circuit to its can (figure 5-5).
- (4) Replace the module cover and screws (figures 5-3 and 5-4).

5.6 1A3A6 BFO and Internal Calibration Module Removal and Replacement

a. 1A3A6 Module Removal

- (1) Remove the module cover (figures 5-3 and 5-4).
- (2) Remove two screws securing the two sandwich-constructed modules to the module can (figures 5-4 and 5-6).
- (3) Disconnect the module plug 1A3A6P1 by loosening the two screws securing it.

CAUTION

The screws must be loosened evenly to prevent damage to the connector.

- (4) Lift the two modules out of the can.

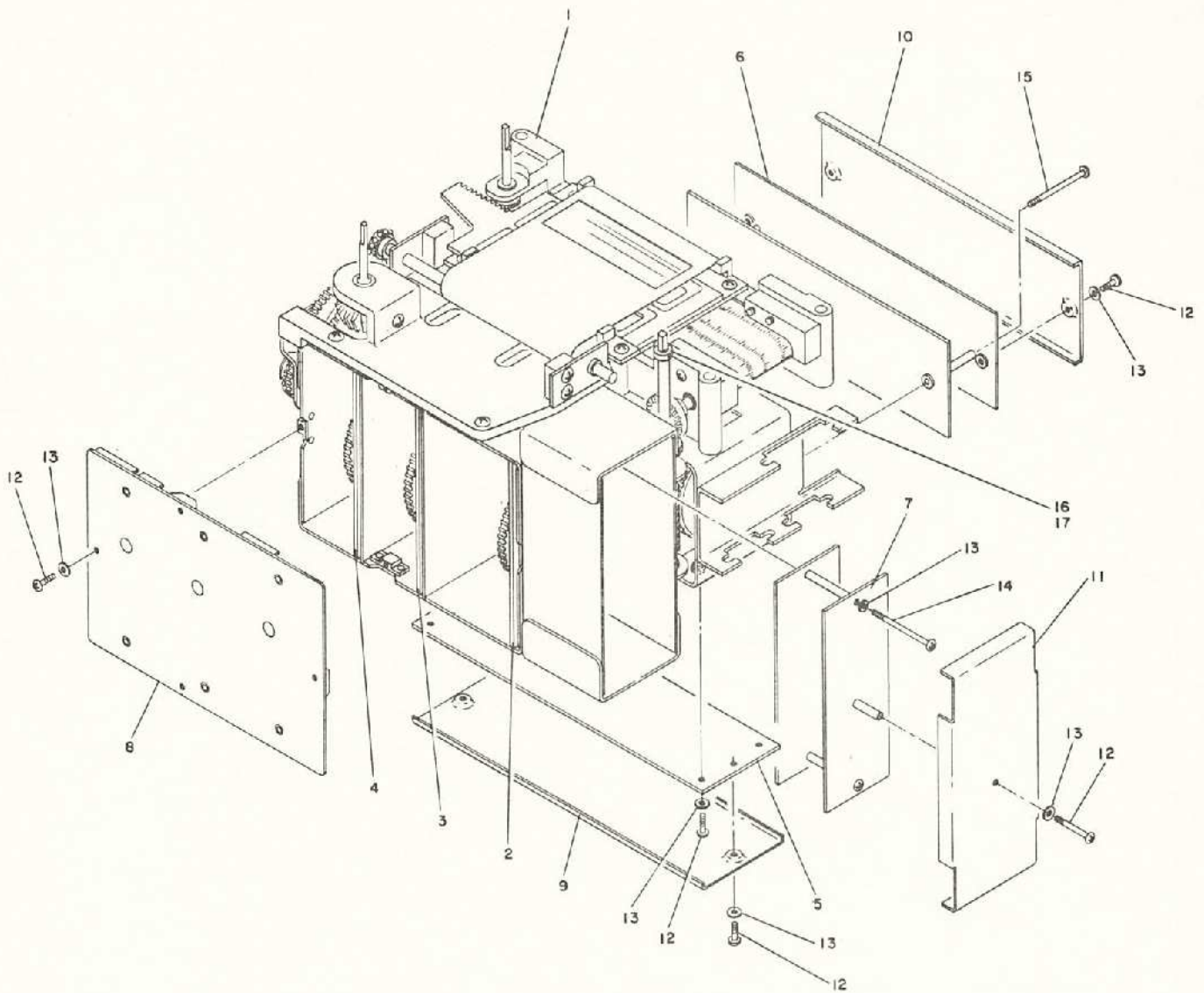

ITEM NO.	PART NO.	DESCRIPTION
1	340843	RECEIVER CHASSIS ASSEMBLY
2	340834	LOCAL OSCILLATOR ASSEMBLY
3	340835	RF AMPLIFIER ASSEMBLY
4	340836	ANTENNA MATCHING ASSEMBLY
5	340845	MIXER, IF ASSEMBLY
6	340846	AUDIO ASSEMBLY
7	340847	BFO & CALIBRATOR ASSEMBLY
8	340848	COVER ASSEMBLY
9	340740	COVER,IF
10	340732	COVER,AUDIO
11	340682	COVER,BFO & CAL.
12	MS51957-3	SCREW
13	MS35338-77	WASHER
14	J03-B1125B500HF	SCREW
15	MS51957-9	SCREW
16	AN565D2H2	SET SCREW
17	J20-1125GBBAA	COLLAR
18	MS51957-5	SCREW

Figure 5-4. RR-224 Receiver Assembly

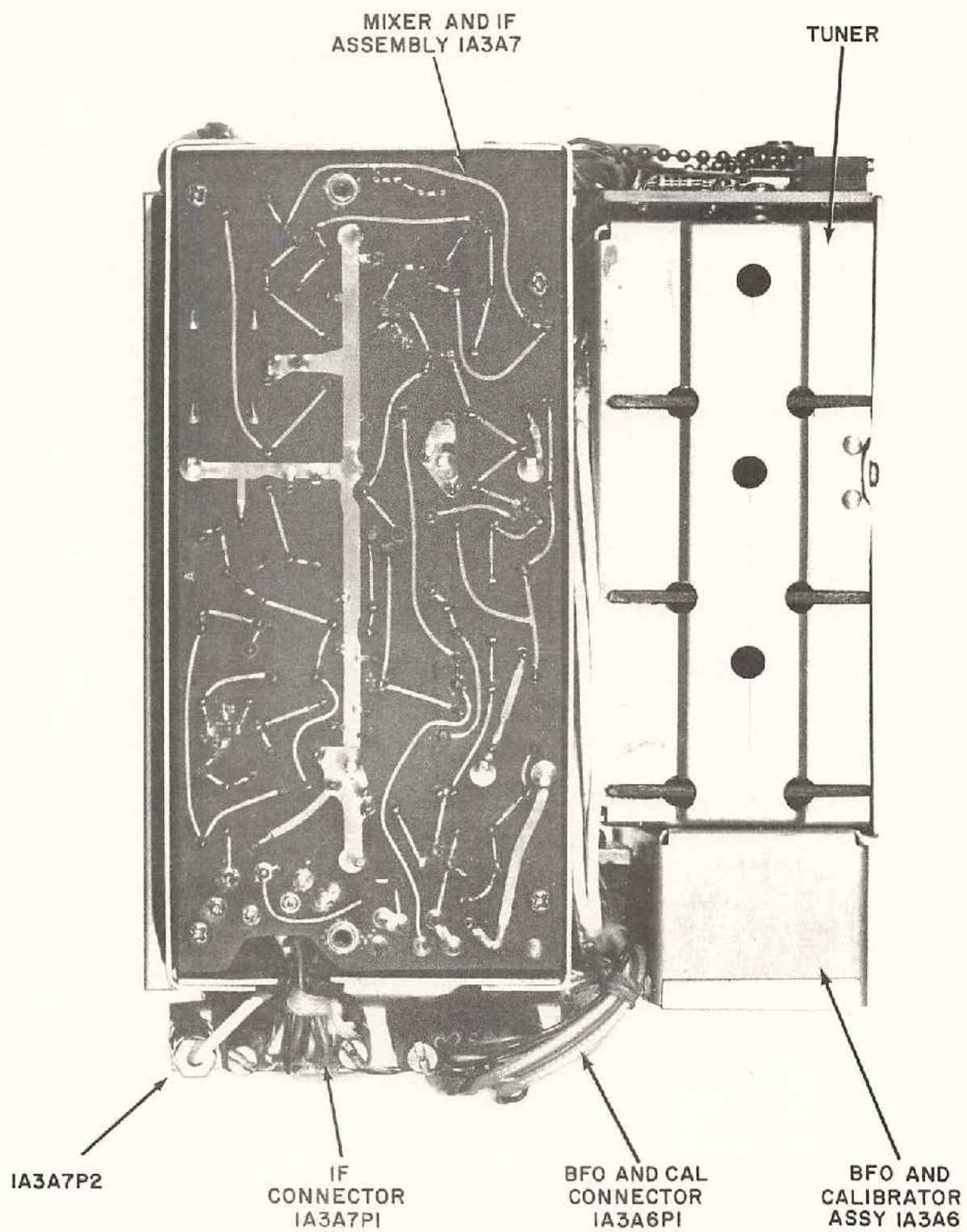

Figure 5-5. RR-224 Module Location (bottom view)

b. 1A3A6 Module Replacement

- (1) Place the module in its can and guide the rubber grommet, which is around the cable, in the slot (figure 5-6).
- (2) Connect the module plug 1A3A6P1 and secure it.
- (3) Replace the screws securing the module in the can (figures 5-4 and 5-6).
- (4) Replace the module cover and the screws (figure 5-4).

5.7 1A3A8 Audio Amplifier and AGC Module Removal and Replacement

a. 1A3A8 Module Removal

- (1) Remove the module cover (figure 5-7).
- (2) Remove two screws securing the module to the can (figures 5-4 and 5-8).
- (3) Disconnect the module plug by loosening the two securing screws (figure 5-7).

CAUTION

The screws must be loosened evenly to prevent damage to the connector.

- (4) Lift the module out of the can.

b. 1A3A8 Module Replacement

- (1) Place the module in the can and guide the rubber grommet, which is around the cable, into the slot (figures 5-4 and 5-8).
- (2) Position the module plug and secure it to the jack (figures 5-4 and 5-8).
- (3) Replace the screws securing the module to the can (figures 5-4 and 5-8).
- (4) Replace the module cover (figure 5-7).

5.8 1A3A2 Antenna Matching Module, 1A3A3 RF Amplifier Module, and 1A3A4 Local Oscillator Module Removal and Replacement

Since removal of modules 1A3A2, 1A3A3, and 1A3A4 is identical, only one will be discussed.

a. Module 1A3A2, 1A3A3, or 1A3A4 Removal

- (1) Position the receiver readout dial in BAND 1.
- (2) Remove the tuner cover (figures 5-4 and 5-9).
- (3) With a common screwdriver carefully pry up the lower edge of the module (from the slots on the side of the can) until it is free of its mating connector and the gear train.

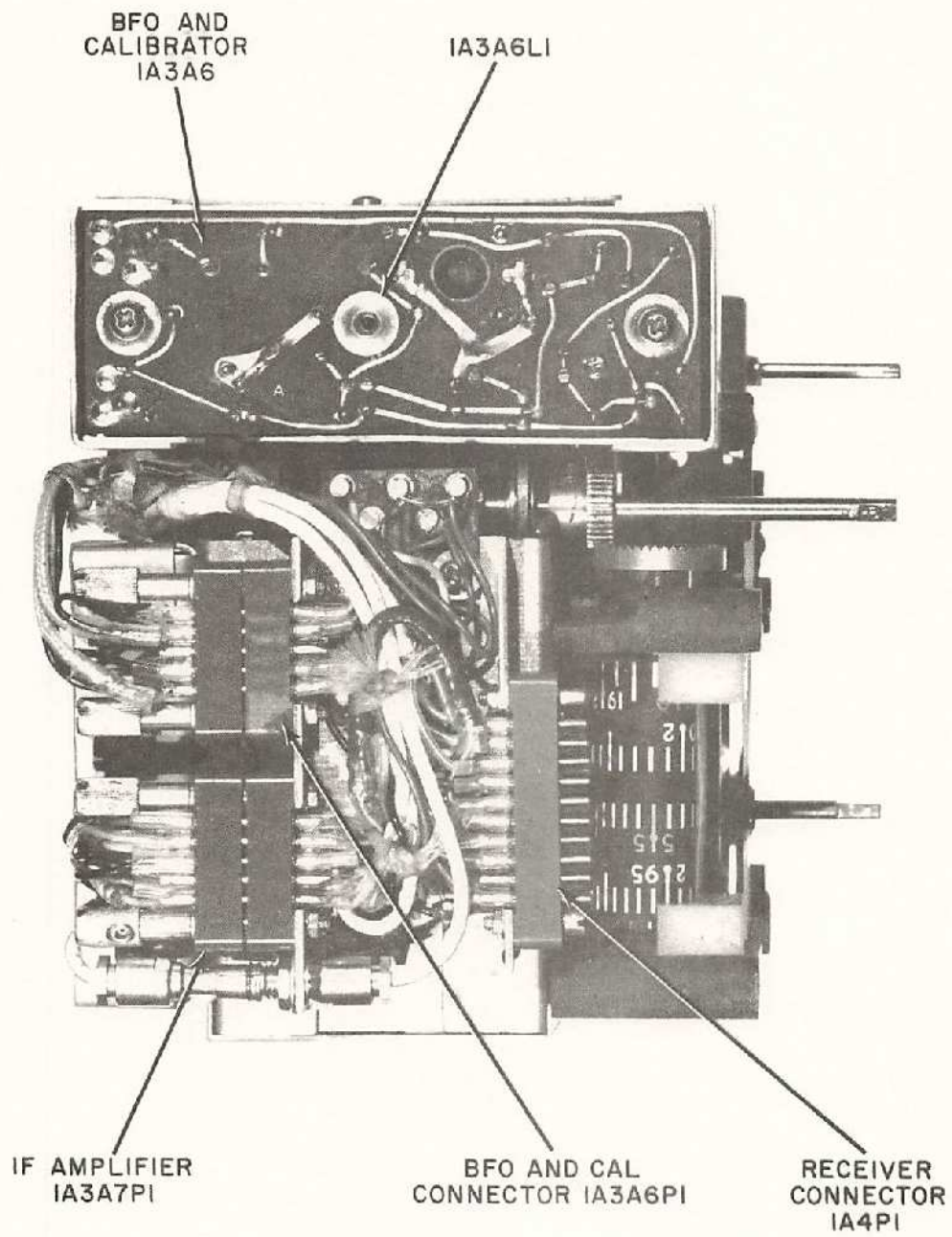

Figure 5-6. RR-224 Module Location (right side view)

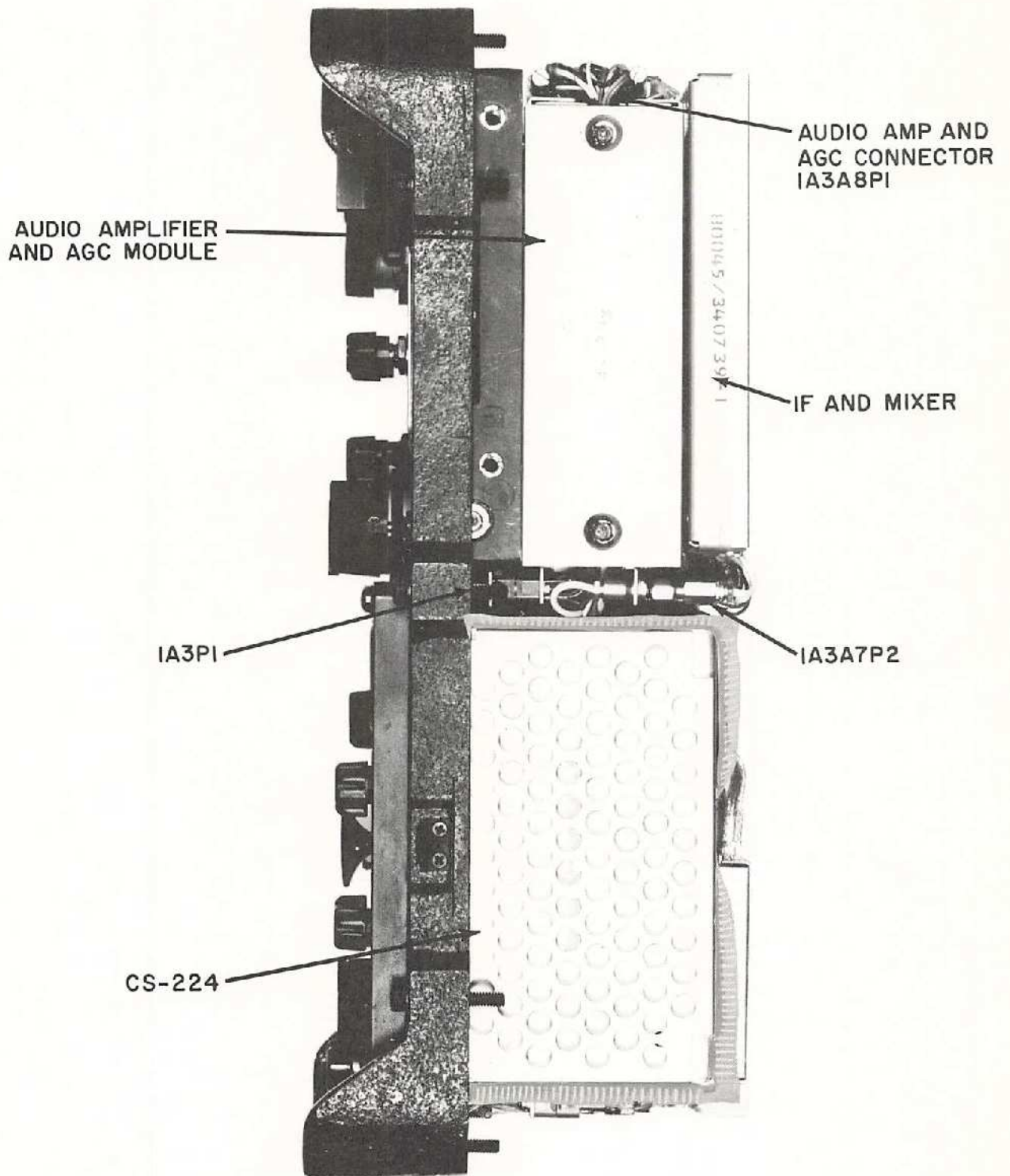

Figure 5-7. RR-224 Module Location (top side view)

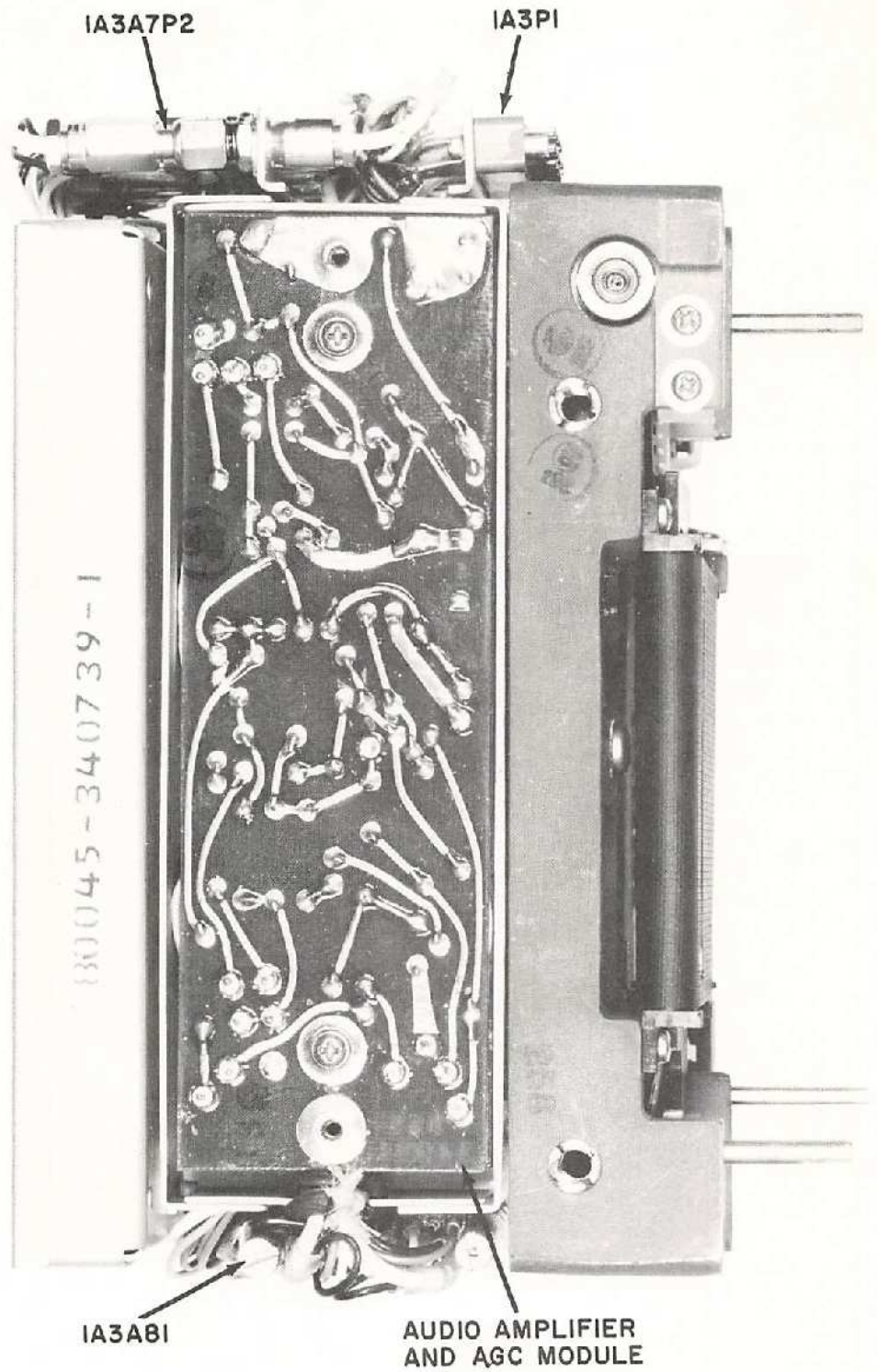

Figure 5-8. RR-224 Module Location (left side view)

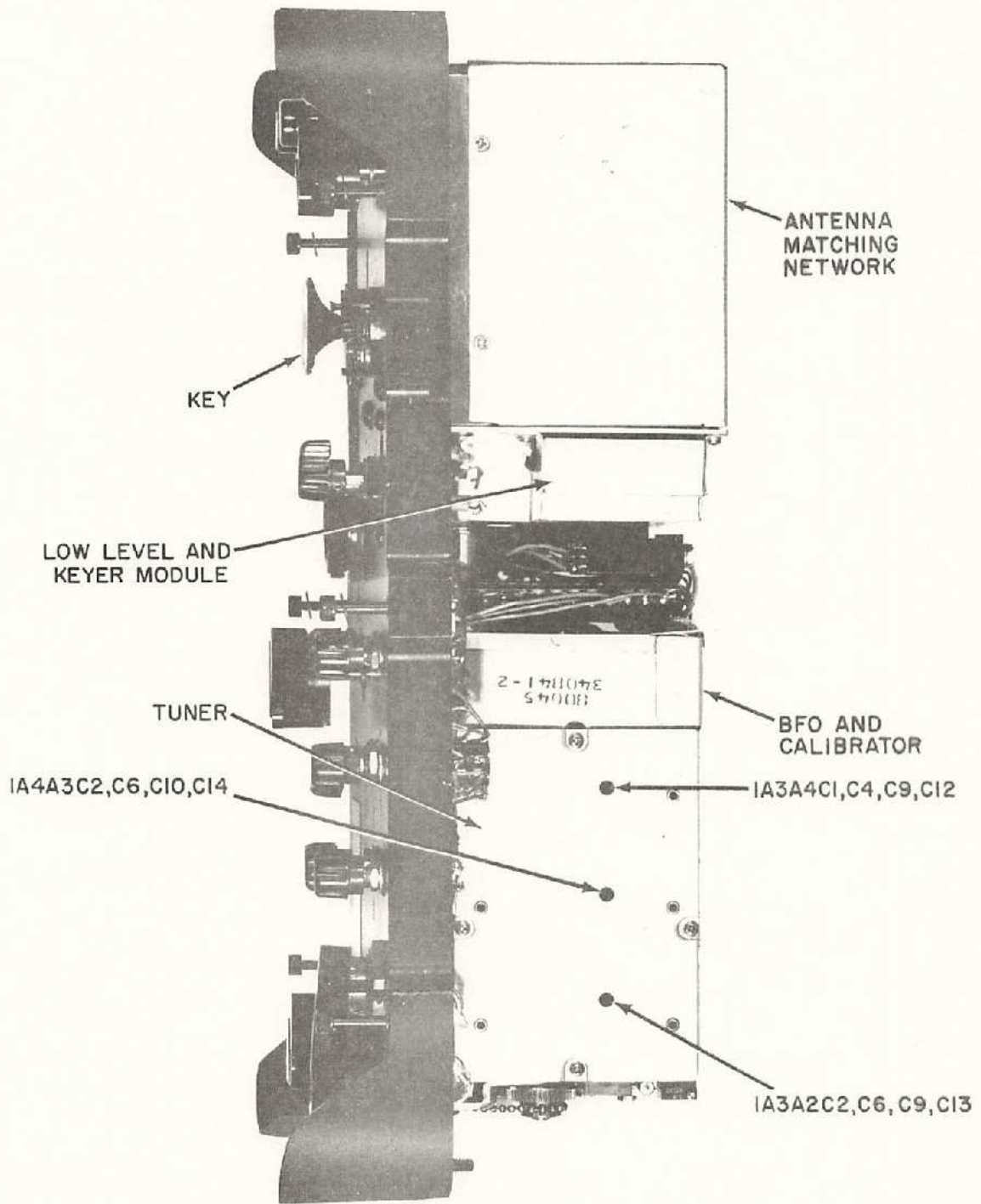

Figure 5-9. TAR-224 Module Location (bottom side view)

b. Gear Assembly Removal and Replacement

Since the removal of the gear assemblies 1A3A2A2, 1A3A3A2, and 1A3A4A2 is identical, only one will be discussed.

- (1) To remove the gear assembly, remove the self-locking nut and washer and slide it off the shaft (figures 4-1 and 4-2).
- (2) To replace the gear assembly, place it on the shaft and replace the washer and self-locking nut. Be sure that the brass bushing is in place on the shaft before replacing the gear assembly. Tighten the self-locking nut until there is a slight drag on the assembly when it is turned.

c. Module 1A3A2, 1A3A3, 1A3A4 Replacement

- (1) Line up the mark on the gear face with the mark on the circuit board (figure 5-10), being sure that the wheel has detented properly.
- (2) Rotate the gear one tooth away from the mark toward the notched side of the board. When the board is inserted, the meshing of the wheel and drive gear will cause an approximate one-tooth rotation of the wheel in a direction away from the front of the receiver.
- (3) Having made sure the board is plugging into the proper location, hold the wheel in the correct position (paragraph 5.8c(1)) and gently push the board into place.
- (4) Check that the marks on the wheel and board line up correctly. If they do not, extract the card and repeat the above steps.
- (5) Once the boards correctly align, replace the tuner cover (figures 5-4 and 5-9).

5.9 Interwiring Board 1A3A1 Removal and Replacement

a. 1A3A1 Removal

- (1) Remove the two screws securing the board to the receiver (figures 5-4 and 5-11).
- (2) Unsolder and tag the wires going to the board.

b. 1A3A1 Replacement

- (1) Solder the previously tagged wires to the board.
- (2) Replace the board on the receiver being sure that the actuator on microswitch S1 is in the notch on the cam, gear assembly (36) (figure 5-11).
- (3) Replace the two screws that secure the board to the receiver.
- (4) Rotate the receiver bandswitch while checking switch S1 contacts with a VOM meter. The switch should activate between bands to mute the receiver. If adjustment is necessary, loosen the two screws securing the board (figure 5-11) and adjust the board for proper action.

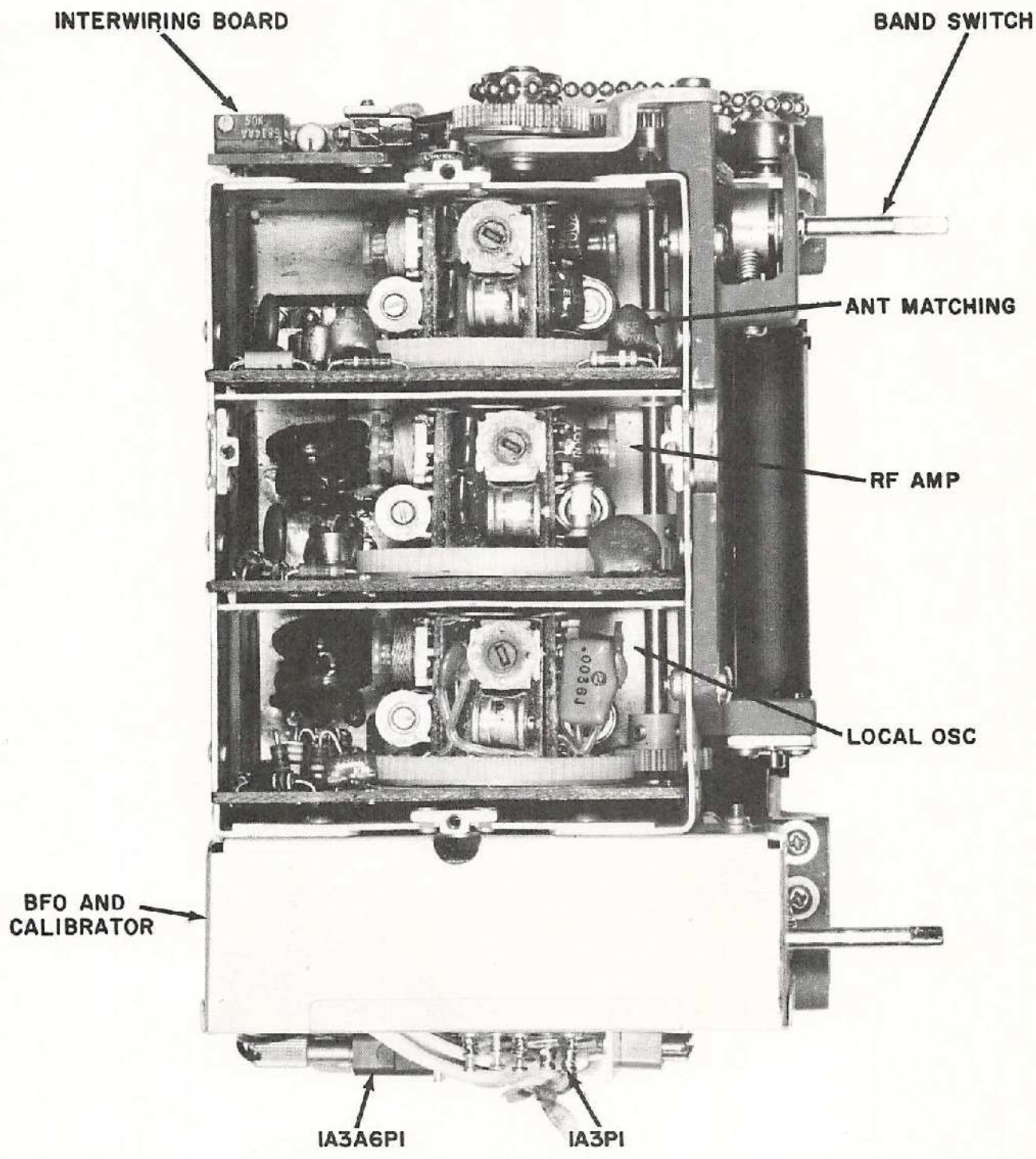

Figure 5-10. RR-224 Tuner

ITEM NO.	PART NO.	DESCRIPTION
1	340698-1	MOUNT, RECEIVER
2	340714	CAPACITOR
3	340702-1	BRACKET, CHASSIS
4	2106-02-01	LUG, TERMINAL
5	340810-1	BOARD, TERMINAL
6	340646	BEARING
7	J25-1JJFCCKE	NUT, SPANNER
8	MS51973-8	SCREW, SET
9	J79-200B53H31KA	SHAFT
10	340597	GEAR
11	340596	FACE GEAR
12	340664	GUIDE
13	J26-1390U256ALA	SPOOL
14	340614	PIN, RETAINING
15	340661	PLATE, PRESSURE
16	340590	TAPE, READOUT
17	340636	PLATE, VERNIER
18	340643	GUIDE
19	340724	MASK ASSEMBLY
20	340662	SPROCKET
21	340699	SUPPORT
22	J30-1062GLJN	SPACER
23	5555-12MD	RETAINING RING
24	MS16633-1012	RETAINING RING
25	340755	SHAFT ASSEMBLY
26	340649	SHAFT
27	127-90	BEARING
28	X5133-18MD	RETAINING RING
29	340793	GEAR, MITER
30	340811	STOP
31	340632	GEAR
32	J14-3135M0050ML	WASHER
33	127-55	BEARING
34	340788	BEAD BELT
35	340844	INTERWIRING BOARD
36	340842	GEAR PLATE ASSEMBLY
37	340841-1	SHIELD, TUNER
38	340739-1	SHIELD, IF & MIXER
39	340730-1	SHIELD, AUDIO
40	27-32	CONNECTOR
41	MS51959-2	SCREW
42	MS51957-2	SCREW
43	MS51957-13	SCREW
44	MS51957-14	SCREW
45	MS51957-28	SCREW
46	MS51957-31	SCREW
47	MS51053-113	SCREW
48	MS15795-702	WASHER
49	MS51957-8	SCREW
50	MS51053-102	SCREW, SET
51	2531-01-16	GEAR, SPUR
52	MM14-22SGDFS50	CONNECTOR
53	MM26-22SGDFS50	CONNECTOR
54	MM29-22PDGF	CONNECTOR
55	MS15795-702	WASHER, FLAT
56	MS51021-14	SCREW, SET

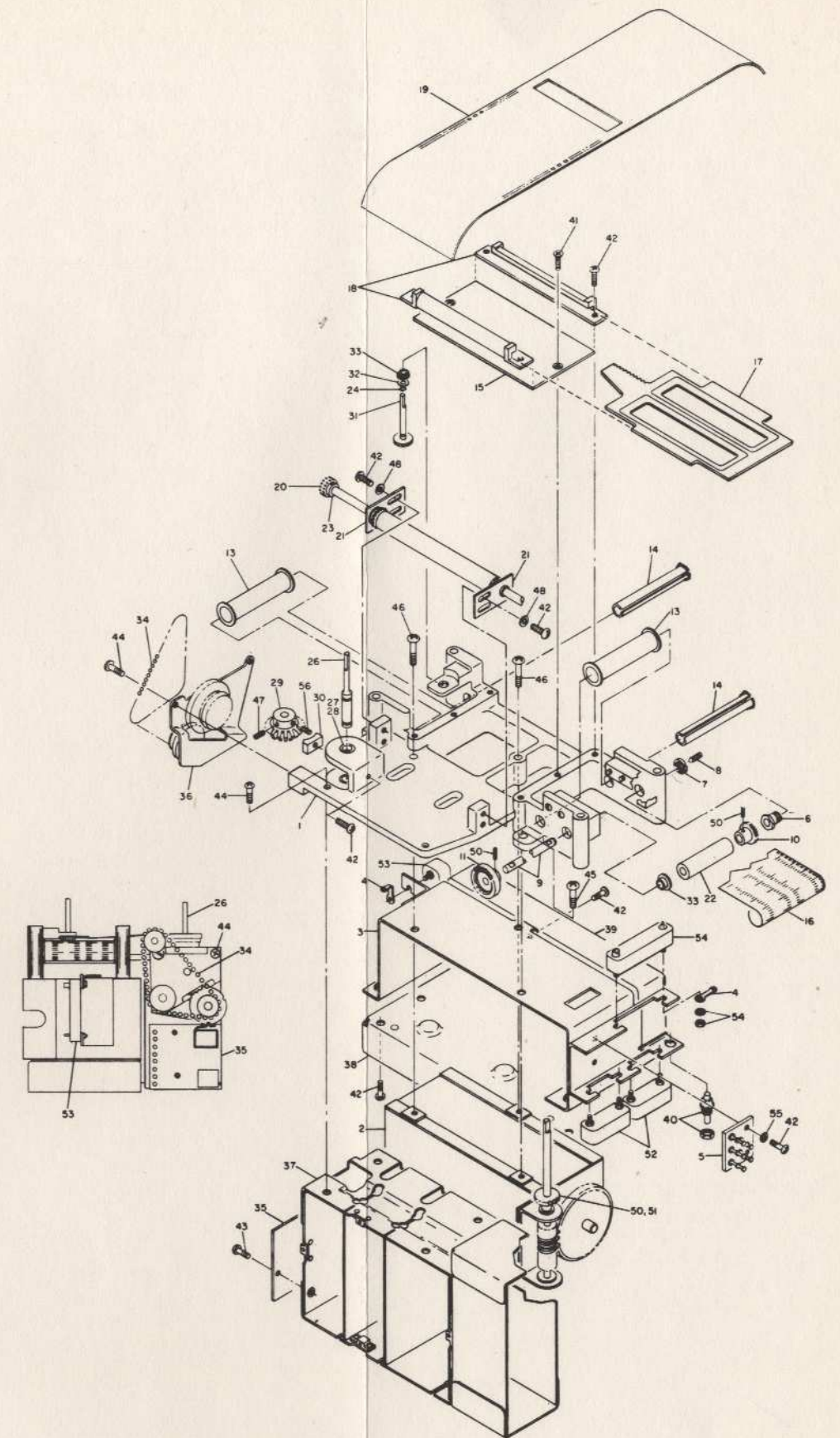

Figure 5-11. RR-224 Receiver Assembly, Exploded View

5.10 Removal and Replacement of Receiver Tape Readout

a. Removal of Tape Readout

NOTE

IMPORTANT: Read instructions completely before starting.

- (1) Before removing the receiver from the front panel, accurately set the dial to 2 MHz in BAND 1 using the built in calibrator.
- (2) Remove the receiver from the front panel, being very careful not to disturb the vernier dial setting or the receiver TUNE control. See paragraph 5.4.
- (3) Position the receiver so that the front is facing up.
- (4) Locate the crown gear (11) that is connected to the tape readout drive shaft (9).
- (5) There are two set screws (50) on the crown gear (11). One set screw should be at the top of the crown gear and the other should be on the left. Rotate the receiver tune shaft counterclockwise until the set screw, that was on the left, is on top; then loosen. Again rotate the tune shaft, this time clockwise, so that the second set screw is now on top and 2 MHz on the tape readout is positioned correctly; then loosen. Push the crown gear (11) away from the tune shaft gear (51). Do not allow the tune shaft to rotate or the two gears to mesh.
- (6) Remove the two tape readout guides (12).
- (7) Remove the vernier dial (17) by sliding it out the end where the guides (12) were attached.
- (8) Remove the pin (17) from the spool (13) at the end opposite that of the receiver tune shaft. Remove the spool by rotating it outward while holding the tape on the spool.
- (9) Gently pull the tape out from the left side, being very careful not to allow the crown gear (11) to mesh with the drive gear (51).

b. Replacement of Tape Readout (figure 5-11)

- (1) Replace spool (13) and pin (14) on the left side of the receiver.
- (2) Roll the tape (16) so that the high frequency numbers are on the outside of the roll.
- (3) Carefully feed the end of the tape under the tape spacer (22), making sure the holes in the edge of the tape are toward that side of the receiver where the audio module is mounted. Allow the tape to curl around the spool. Permit an inch or so of tape to extend as a "tab".
- (4) Bring the tape tab up and over the tape spacer (22) and carefully feed it under the mask assembly (19) through to the other side and let it curl around the spool (13) on the left side of the receiver. Be careful not to allow the crown gear and drive gear to mesh.
- (5) Replace the vernier dial and adjust it to the midpoint position.
- (6) Replace the two tape guides (12).

- (7) Push the tape through until the 2 MHz reading on the tape corresponds to the center marking on the vernier dial, where it is in its midposition. Be careful that the crown gear and drive gear do not mesh.
- (8) Turn the crown gear (11), without meshing with the drive gear (31), until one of the set screws is on top and the other is on the left.
- (9) Mesh the crown gear (11) with the drive gear (51) and tighten the top set screw. Rotate the tune shaft counterclockwise until the second set screw is on top, then tighten.
- (10) Check the back lash between the crown gear (11) and the drive gear (51). If back lash is excessive, adjust the set screw (50), located in the spanner nut (7).
- (11) Replace receiver on front panel (see paragraph 5.4).
- (12) Check receiver calibration at 2 MHz and 3.7 MHz. Be sure that the frequencies are within the range of the vernier dial travel.

5.11 Receiver Tuning Capacitor Removal and Replacement (See figure 5-10)

CAUTION

Read completely before starting procedure.

a. Receiver Tuning Capacitor Removal

- (1) Follow procedure for tape readout removal paragraph 5.10b, (5) through (9).
- (2) Remove the IF module; see paragraph 5.5.
- (3) Remove the IF mixer can by removing the four screws (42).
- (4) Remove the audio module; see paragraph 5.7.
- (5) Remove the audio module can (39) by removing the three screws.
- (6) Remove the calibrator, BFO module; see paragraph 5.6.
- (7) Remove the receiver interwiring board (35); see paragraph 5.4.
- (8) Locate the three coaxial cables going to the tuning capacitor (2) and unsolder from the capacitor.
- (9) Remove the two screws from the pressure plate (15) and slip the pressure plate from under the mask assembly (19). Rotate the mask assembly away from the receiver.
- (10) Remove the screw holding upper vernier guide (18) and slip the guide from under the mask assembly (19).
- (11) Turn the receiver so that the front is facing up. Locate the three screws (45, 46) on the receiver mount (1) and loosen.
- (12) Rotate the receiver forward so that the front of the receiver is facing you. Place so that the audio module can is up. Carefully pull the capacitor (2) and the bracket (3) away from you until the capacitor just overhangs the back of the receiver. Rotate the bracket (3) 180 degrees away from you. Remove the capacitor.

b. Receiver Tuning Capacitor Replacement

CAUTION

Read completely before starting procedure.

- (1) Hold the receiver capacitor so that the gears are visible. Turn the tuning knob until the scribe mark on the large gear matches exactly with the scribe mark on the flange of the capacitor when the capacitor is toward maximum capacitance (full mesh).
- (2) With the bracket (3) rotated, as in paragraph 5.11b (12), place capacitor on the RF tuner can. Rotate the bracket (3) 180 degrees toward you. Move both the bracket and the capacitor toward you, being careful not to turn the capacitor shaft.
- (3) Replace the three screws that hold the capacitor and bracket to the receiver mount (1).
- (4) Turn the receiver so that the front is facing up.
- (5) Put the mask (19) in place over the front on the receiver and replace the vernier guide (18). Replace pressure plate (15).
- (6) Temporarily install the vernier dial (17). Adjust the mask (19) by removing the vernier dial and upper vernier guide until the markings on the vernier dial can be seen when the band switch is in any one of its four positions.
- (7) Remove vernier dial. Replace readout tape, paragraph 5.11b, (1) through (10). Note that the scribe lines on the capacitor, paragraph 5.11b(1) represent 2 MHz on the tape readout.
- (8) Replace receiver interwiring board; see paragraph 5.4.
- (9) Solder the three coaxial cables, that came from the tuner parent board, to the capacitor.
- (10) Replace the audio module can (39) with its three screws. Use care with the wire harness routing.
- (11) Replace audio module; see paragraph 5.7.
- (12) Replace IF mixer module can (38).
- (13) Replace IF mixer module; see paragraph 5.5.
- (14) Replace calibrator BFO module; see paragraph 5.6.
- (15) Replace receiver on front panel; see paragraph 5.4.
- (16) Check the receiver calibration at 2 MHz and at 3.7 MHz to be sure that the frequencies are within the range of the vernier dial movement.

5.12 RT-224 Transmitter (1A4) Removal and Replacement

a. 1A4 Removal

- (1) Remove the transmitter BAND switch knob and PULL TO COARSE TUNE knob and remove the retaining ring from the PULL TO COARSE TUNE shaft (figure 5-1).
- (2) Remove the TAR-224 case as detailed in paragraph 5.3a.

- (3) Remove six common screws holding the transmitter to the front panel (figure 5-1).
- (4) Disconnect RF connector 1A1A2P1 (figure 5-12.)
- (5) Reposition the CS-224 to your left and loosen the transmitter connector 1A4P1 (figure 5-13).
- (6) Remove the transmitter by lifting straight up (figure 5-3).

b. 1A4 Replacement

- (1) Place the front panel face side down.
- (2) Place a thin coating of Wakefield thermal compound on that portion of the transmitter that mates with the front panel.
- (3) Place the transmitter onto the front panel making sure the shafts and antenna connector fit their holes (figure 5-14) and that the O-ring is in place on the tune shaft bushing collar.
- (4) Replace 1A4P1.
- (5) Reconnect RF connector 1A1A2P1 to 1A4J6 (figure 5-15).
- (6) Replace the six screws securing the transmitter to the front panel (figure 5-1).
- (7) Replace the radio set case as detailed in paragraph 5.3b.
- (8) Replace the retaining ring on the TUNE shaft and then replace the knob and replace the BAND switch knob.

5.13 1A4A7 Low Level Module Removal and Replacement

a. 1A4A7 Module Removal

- (1) Remove 7 screws holding the module cover (13) in place (figures 5-14 and 5-16).
- (2) Remove five screws (20) securing the low level module (figures 5-11 and 5-15).
- (3) Remove the nut and washer from the band switch.
- (4) Unplug the low level module and remove it and the switch from the bracket.
- (5) Carefully unsolder the reflect ALC coax, the forward ALC coax, the receiver spot coax, coax to 1A4J6, and the low level module key line. Disconnect the RF sampler control lines from the band switch.
- (6) If the low level board is to be replaced, unsolder band switch wires at the board.

b. 1A4A7 Module Replacement

- (1) Connect the band switch wires to the board.
- (2) Connect the RF sampler control lines to the band switch.

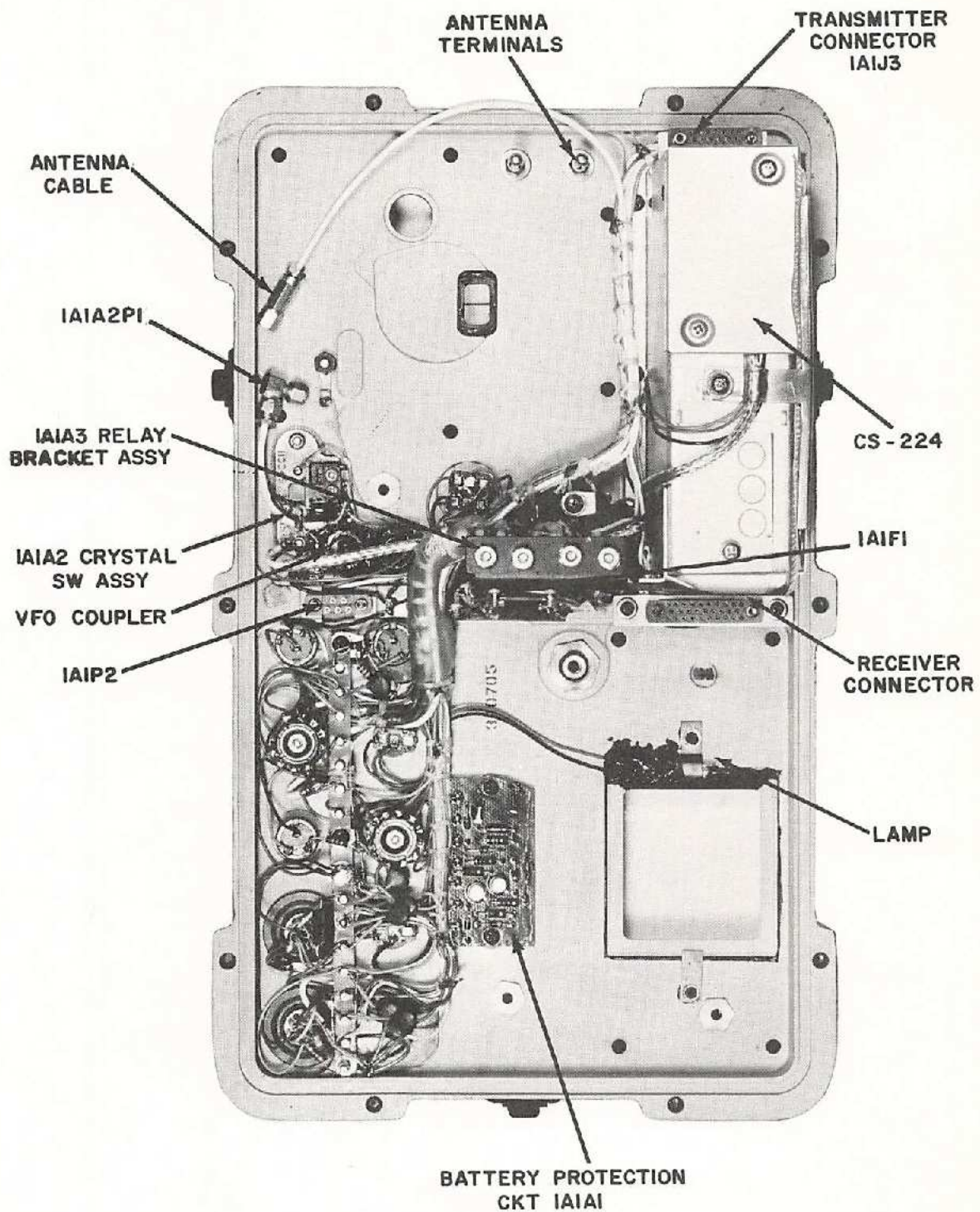

Figure 5-12. TAR-224 Front Panel (bottom view)

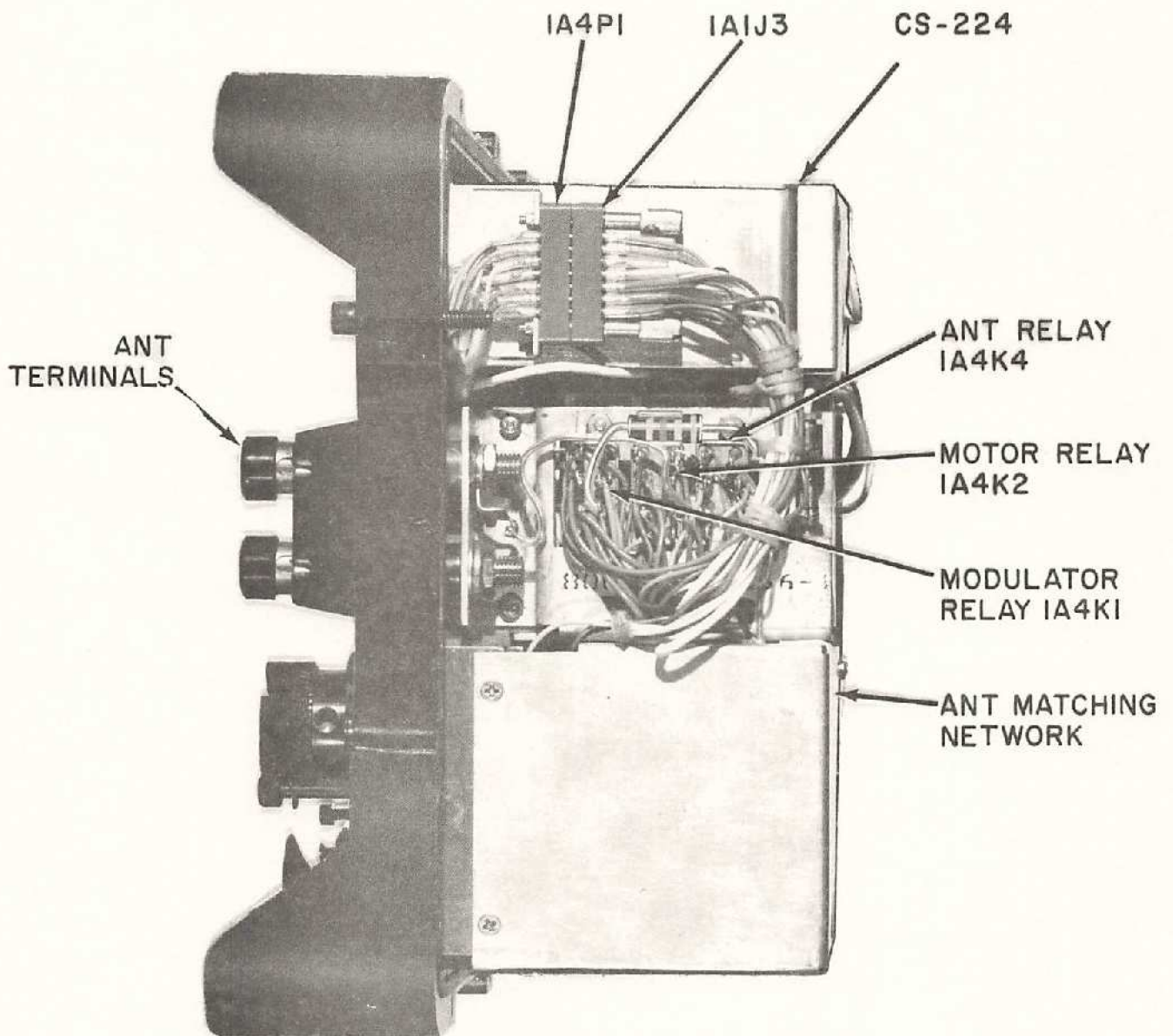

Figure 5-13. TAR-224 Module Location (right side view)

ITEM NO.	PART NO.	DESCRIPTION
1	340801	HEAT SINK ASSEMBLY
2	340823	CAPACITOR, VAR. ASSEMBLY
3	340824	INDUCTOR ASSEMBLY
4	340756-1	BRACKET, RELAY MOUNTING
5	340780-1	BOARD, INTERWIRING
6	340759	RF SAMPLER ASSEMBLY
7	340830	MOTOR CONTROL NO. 1
8	340831	MOTOR CONTROL NO. 2
9	340764	MODULATOR ASSEMBLY
10	340694-1	SHIELD
11	340757	KEYING CIRCUIT ASSEMBLY
12	340747	LOW LEVEL MODULE
13	340776	SHIELD, LLM
14	340790	SHIELD, MATCHING NETWORK
15	340177	INSULATOR
16	340936-3	COVER
17	340825	ANTENNA TUNE MOD.
18	340976	SWITCH
19	340777	BRACKET
20	MS35206-202	SCREW
21	MS35206-214	SCREW
22	MS35206-202	SCREW
23	MS35649-222	NUT
24	MS35337-39	WASHER, LOCK
25	MS35337-40	WASHER, LOCK
26	MS35338-39	WASHER, LOCK
27	23MS27183-2	WASHER, FLAT
28	340695-1	TERMINAL BOARD ASSEMBLY
29	340748	LINE BORE ASSEMBLY
30	MS24693-CB2	SCREW
31	340773	SHIELD
32	340775-1	BRACKET, MOUNTING ASSEMBLY
33	MS35198-2	SCREW
34	MS35206-202	SCREW
35	340005	CLAMP
36	MS35490-4	GROMMET
37	340502	GEAR MOTOR
38	MS35198-3	SCREW
39	SX-2332	RELAY
40	SX-2333	RELAY
41	340668	SHAFT
42	5133-25H	RETAINER RING
43	MS28775-014	"O" RING
44	MS35649-245	NUT
45	MS35338-40	WASHER, LOCK
46	MS35206-203	SCREW, PAN HEAD
47	MS35245-21	SCREW
48	1SX1-T	SWITCH

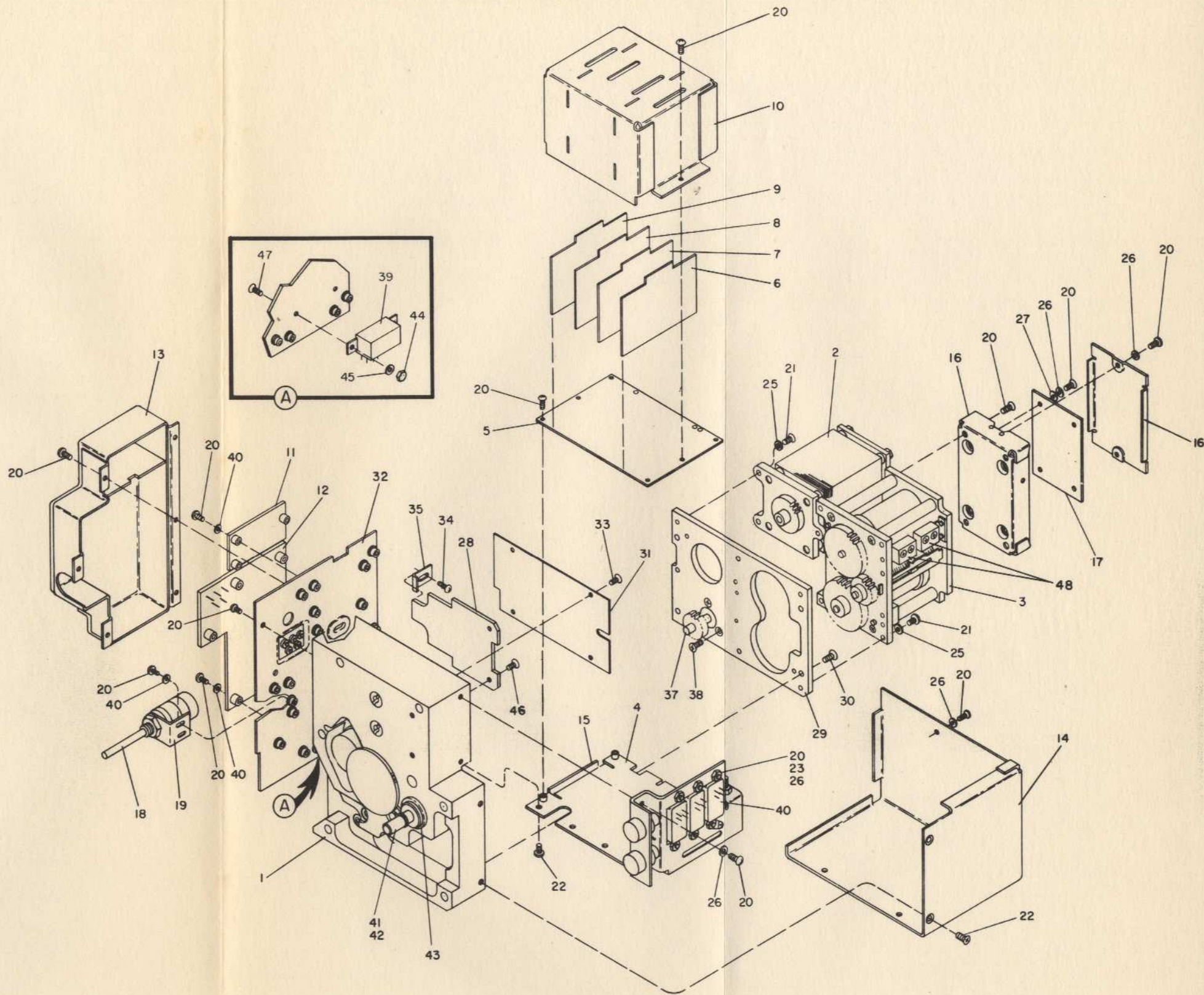

Figure 5-14. Transmitter Assembly

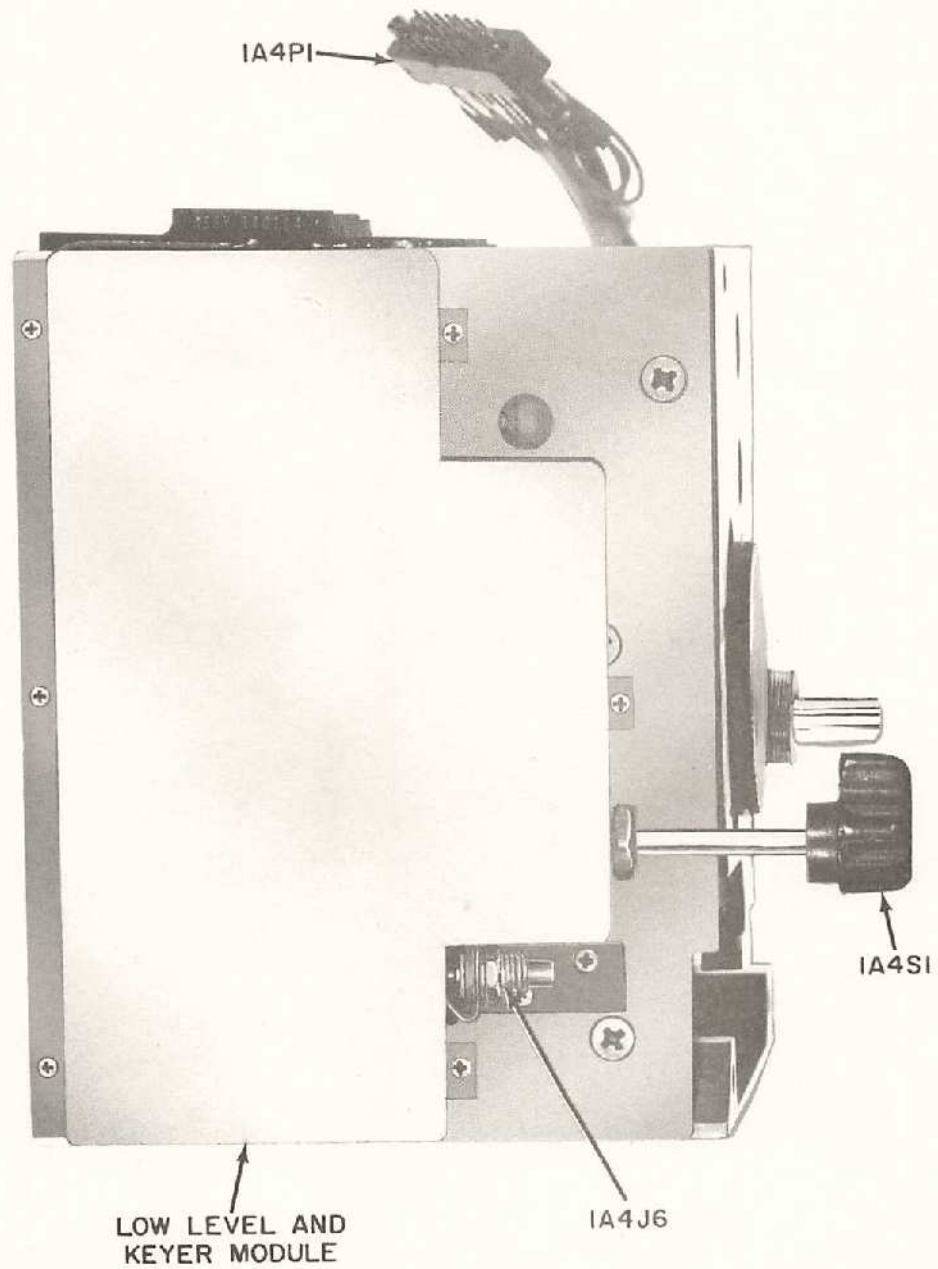

Figure 5-15. RT-224 Low Level Module and Keyer Module (shield installed)

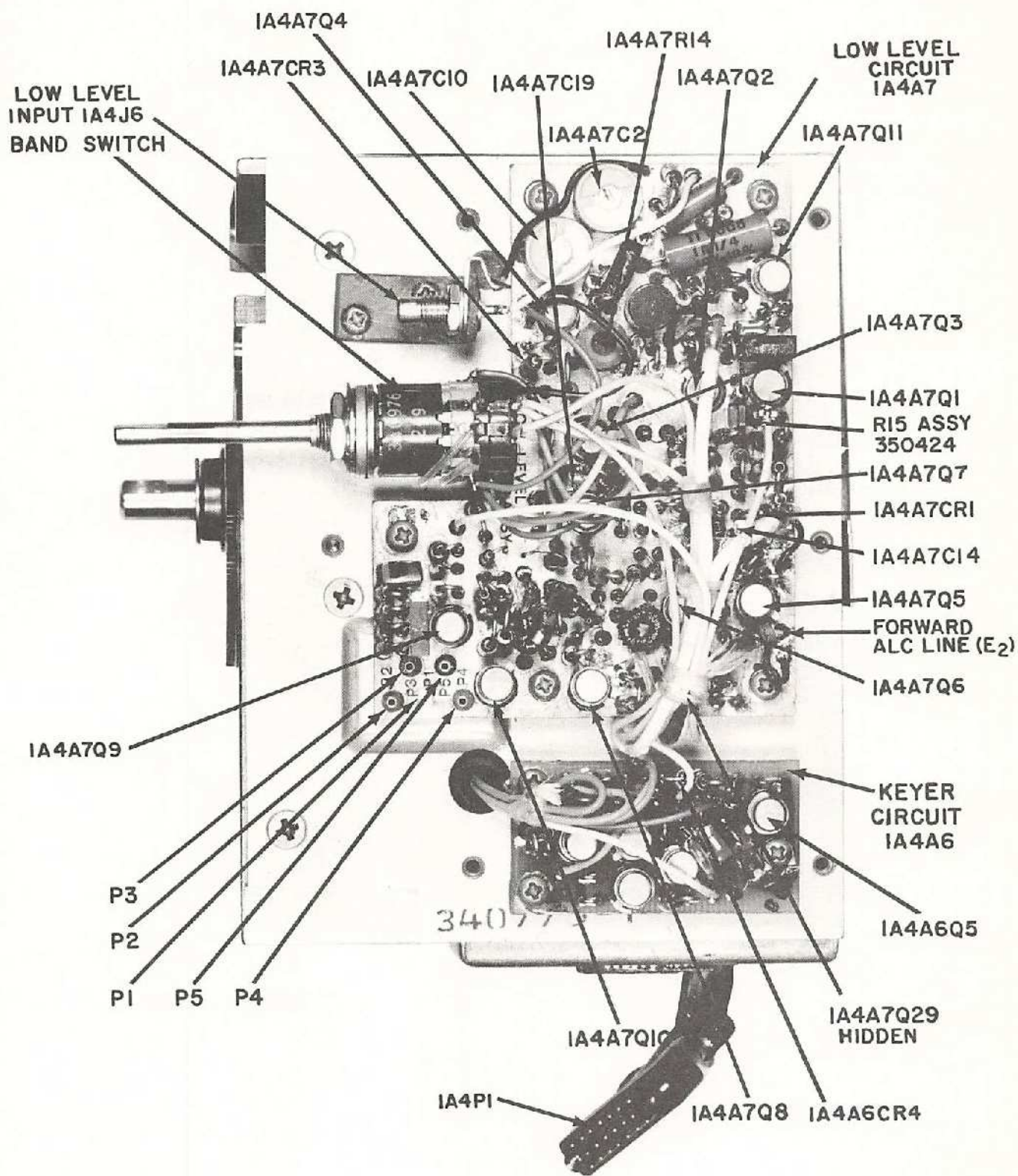

Figure 5-16. RT-224 Low Level Module and Keyer Module (shield removed)

- (3) Connect the key line, the receiver coax and the forward and reflected ALC coaxes.
- (4) Replace the module and the switch on the bracket.
- (5) Replace the five screws securing the low level module to the transmitter chassis and the nut and washer on the band switch.
- (6) Replace the module cover (figure 5-16).

5.14 1A4A6 Keyer Module Removal and Replacement

a. 1A4A6 Module Removal

- (1) Remove seven screws (20) holding the module cover (13) in place (figures 5-14 and 5-15).
- (2) Remove three screws securing the module to the transmitter chassis (figures 5-14 and 5-15).
- (3) Tilt the module away from the chassis to service or unsolder and tag the 10 wires connected to the module (figure 5-16).

b. 1A4A6 Module Replacement

- (1) Resolder the 10 tagged wires removed in the previous paragraph.
- (2) Position the module on the chassis and replace the three screws securing it to the transmitter chassis (figures 5-14 and 5-15).
- (3) Replace the module cover (figures 5-14 and 5-15).

5.15 1A4A2 RF Sampler Module, 1A4A3 Motor Control Module, 1A4A4 Motor Control Module, and 1A4A5 Modulator Module Removal and Replacement (Refer to figure 5-14)

a. Removal. The removal of modules 1A4A2, 1A4A3, 1A4A4, and 1A4A5 is identical, except for the RF sampler module 1A4A2 (figure 5-17). Access to the module is gained by removing the two screws and the cover and pulling the modules out of the parent board 1A4A9 for servicing or replacement. When removing the RF sampler module 1A4A2, the two wires for the RF input and RF output must be unsoldered before the module can be removed (figure 5-17).

b. Replacement. The replacement of modules 1A4A2, 1A4A3, 1A4A4 and 1A4A5 is identical except for module 1A4A2. The modules are placed over the guide pins and pushed down to mate with the parent board connector (figures 5-14 and 5-17). Module 1A4A2 is inserted in the same manner but the two wires, RF input and RF output, must be resoldered (figure 5-17). After replacing all the modules, the cover (10) and the two screws are replaced.

5.16 Antenna Tuning Module 1A4A1 Removal and Replacement (Refer to figure 5-14)

a. Antenna Tuning Module Removal

- (1) Remove the two screws securing the cover (19) (figure 5-14).
- (2) Unsolder the RF input and output wires.
- (3) Remove the four screws (26) securing the board (19) to the can (18).
- (4) Unsolder the d-c output wire.

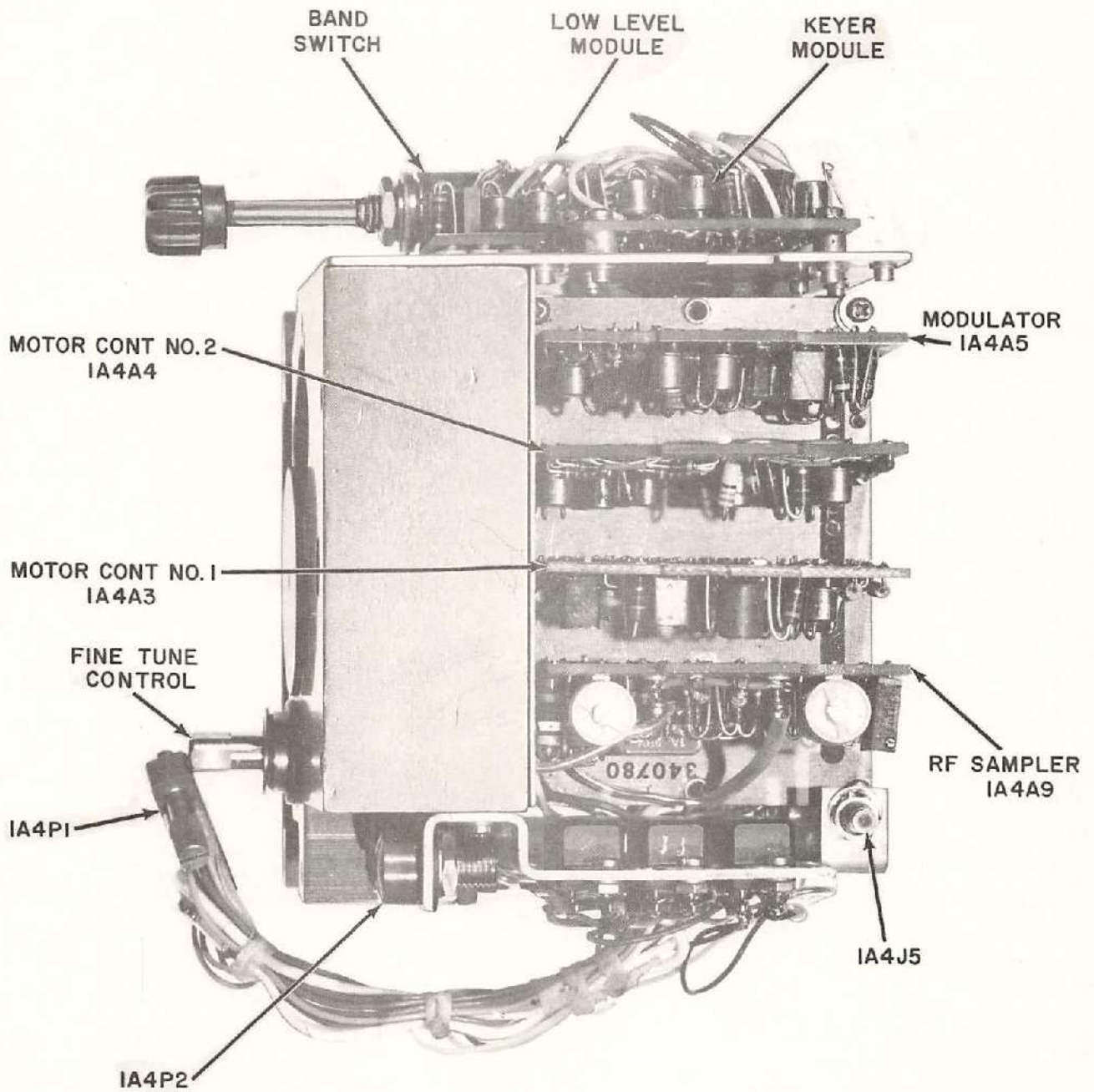

Figure 5-17. RT-224 Module Location (bottom view)

b. Antenna Tuning Module Replacement (Refer to figure 5-14)

- (1) Solder the d-c output wire to the board (19).
- (2) Replace the board and the four screws in the module can (18).
- (3) Resolder the RF input and output wires.
- (4) Replace the cover (19) and its two screws.
- (5) Replace the matching network shield (15).

5.17 Antenna Matching Network Removal and Replacement (Refer to figure 5-14)

a. Parts Removal

- (1) Remove antenna matching network shield (15).
- (2) Variable inductor removal.
 - (a) Remove the antenna tuning module (see paragraph 5.16a).
 - (b) Remove the antenna tuning module can (18).
 - (c) Unsolder and tag the three wires from the microswitches on the inductor (3).
 - (d) Unsolder wire to the variable capacitor.
 - (e) Remove the four retaining screws (27).
 - (f) Carefully lift the inductor up and unsolder the wire connection behind the inductor.
- (3) Variable capacitor removal.
 - (a) Unsolder the connection to the variable inductor.
 - (b) Remove the three retaining screws.
 - (c) Lift the capacitor out.
- (4) Motor removal.
 - (a) Unsolder and tag the red and black wires on the motor reversing relay (39).
 - (b) Remove the motor reversing relay (39).
 - (c) Remove the variable inductor and the variable capacitor. See paragraph 5.17a, (2) and (3).
 - (d) Remove the four flat head screws holding the mounting plate (29) to the heat sink (1) and remove the plate. Check the location of the gear train for future reference.
 - (e) Remove the three flat head screws holding the motor to the mounting plate.

b. Parts Replacement

- (1) Motor replacement.
 - (a) Connect the motor to the mounting plate (29) with three flat head screws.
 - (b) Replace the mounting plate (29) on the heat sink (1) with four flat head screws. Be sure the gear train and guide pins are properly in place.
 - (c) Replace the motor reversing relay (39).
 - (d) Connect motor wires to the motor reversing relay (39).
- (2) Variable capacitor replacement.
 - (a) Place the capacitor (2) with its gear down into its proper position, making sure the gears mesh properly.
 - (b) Replace the three retaining screws. The screw that is connected to the rotor tab is a nylon screw and has a solder lug under it.
 - (c) Connect the rotor to the connection point on the variable inductor (3).

NOTE

If variable inductor has also been removed, step (c) must be performed after the variable inductor is replaced.

- (3) Variable inductor replacement (3).
 - (a) Connect the RF line from the RF sampler to the connection point in the rear of the variable inductor (3).
 - (b) Position the variable inductor (3) on the mounting plate (29) and replace the four retaining screws, being sure that the guide pins are in the proper place.
 - (c) Connect the wire going to the variable capacitor rotor.
 - (d) Replace antenna tuning module (see paragraph 5.16b).
 - (e) Connect the three wires to the microswitches.

5.18 Parent Board 1A4A9 Removal and Replacement

a. Removal

- (1) Remove cover from modules 1A4A2, 1A4A3, 1A4A4, and 1A4A5 (figure 5-17).
- (2) Remove modules 1A4A2, 1A4A3, 1A4A4, and 1A4A5 as outlined in paragraph 5.15a.
- (3) Remove four screws securing the parent board to the chassis.
- (4) Tilt the module up and rotate it 180 degrees away from the transmitter for servicing, or tilt it out and unsolder and tag the wires for removal.

b. Replacement

- (1) Resolder all wires removed in the removal procedure and position the parent board in the chassis.
- (2) Replace four screws securing the parent board to the chassis.
- (3) Replace modules 1A4A2, 1A4A3, 1A4A4, and 1A4A5 as outlined in paragraph 5.15b.
- (4) Replace the cover.

5.19 Driver-Final Section Shield Removal and Replacement

a. Removal

- (1) Reference paragraph 5.18 for the removal of 1A4A9. Do not unsolder the board wiring. Rotate the parent board, 1A4A9, 180 degrees.
- (2) Remove the four screws holding the shield in place.
- (3) Gently remove shield.

b. Replacement

- (1) Place the shield on the heat sink making sure the output wires fit in the slots provided.
- (2) Replace the four retaining screws.
- (3) Replace 1A4A9 per paragraph 5.18b.

5.20 Battery Protection Circuit 1A1A1 Parts Removal and Replacement (Refer to figures 5-12 and 5-18)

a. Removal

- (1) Remove the case (see paragraph 5.3a).
- (2) Remove the receiver (see paragraph 5.4a).
- (3) Remove the two screws and board from the panel.
- (4) Unsolder the necessary parts from the terminals of the battery protection circuit (1).

b. Replacement

- (1) Replace the parts in proper place and solder.
- (2) Replace board and the two screws.

5.21 VFO Coupler 1A1A2 (Part of Crystal Switch Assembly) Removal and Replacement (Refer to figures 5-12 and 5-18)

a. Removal

- (1) Remove the case (paragraph 5.3a).
- (2) Remove transmitter (paragraph 5.12a).

ITEM NO.	PART NO.	DESCRIPTION
1	340450	BATTERY, PROTECT CIR.
2	MS35214-2	SCREW
3	AN960-C2	WASHER, FLAT
4	340944-1	BRACKET, RELAY ASSEMBLY
5	MS35214-12	SCREW
6	MS35338-40	WASHER, SPLIT
7	340715	STRAP
8	23AN505-2R3	SCREW
9	MS35206-202	SCREW
10	MS35338-39	WASHER, SPLIT
11	23MS35649-242	NUT
12	MS35338-41	WASHER, SPLIT
13	MS51021-9	SCREW
14	340038	CRYSTAL SWITCH ASSEMBLY
15	1SX1-T	SWITCH
16	340939	SPRING
17	340610	CLIP, CRYSTAL
18	MS35206-206	SCREW
19	340938	ACTUATOR
20	340717	HOLDER INDICATOR
21	377008	SPRING, BOOSTER
22	MS20003	INDICATOR

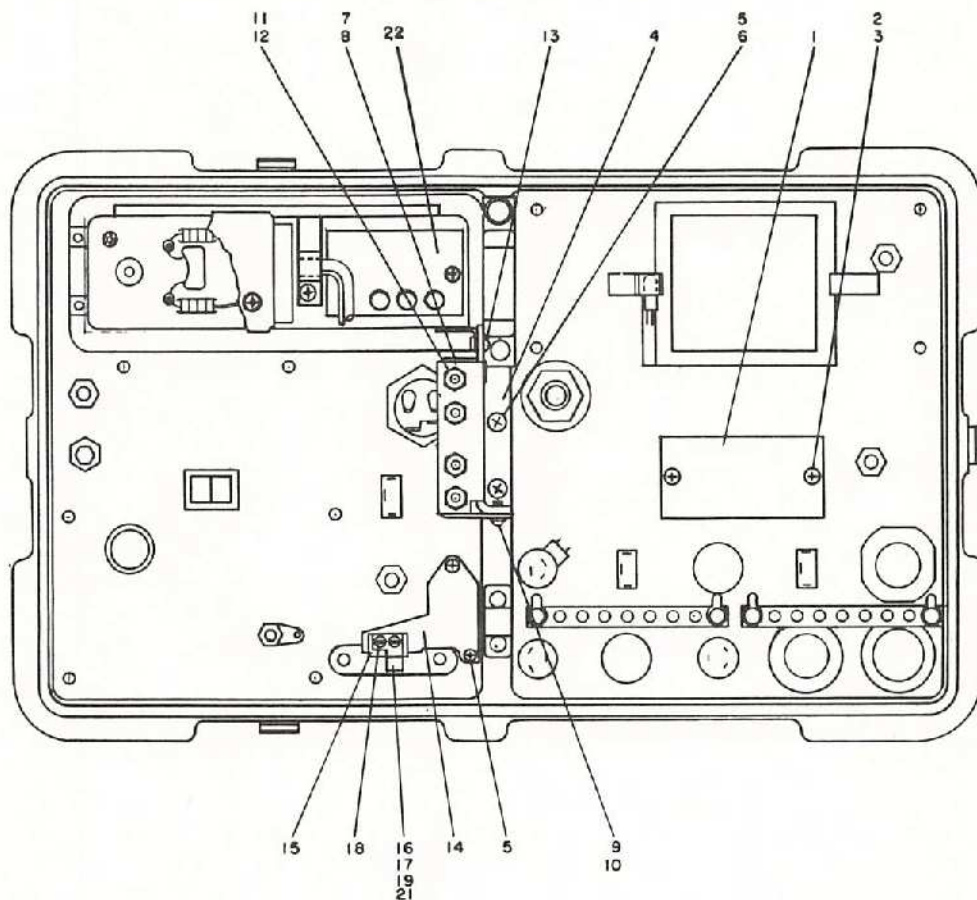

Figure 5-18. Back Panel Assembly

- (3) Remove the two wires going to the crystal socket.
- (4) Remove two screws (5) holding the VFO coupler board (14) to the front panel.
- (5) Remove two screws holding the switch (18) to the crystal socket and remove actuator spring (16), actuator (19), and switch (15).
- (6) Remove the board and unsolder and tag the five remaining wires.

b. Replacement

- (1) Solder the previously tagged wires to the board.
- (2) Replace the board using the two screws (5).
- (3) Replace the switch (15), the actuator (19), the spring (16), and the two screws (18). Be sure that the switch is adjusted for proper actuation when a crystal is inserted in the crystal socket.
- (4) Resolder the wires coming from the crystal socket.
- (5) Replace the transmitter (paragraph 5.12b).
- (6) Replace the case (paragraph 5.3b).

5.22 Relay Mounting Bracket 1A1A3 Parts Removal and Replacement (Refer to figure 5-18)

a. Access to Relay Mounting Bracket

- (1) Remove case (paragraph 5.3a).
- (2) Remove receiver from front panel (paragraph 5.4a).

b. Parts (other than relays) Removal and Replacement

- (1) Removal.
 - (a) Referring to the receiver side of the relay mounting bracket (4), locate the part to be replaced.
 - (b) Unsolder and remove part.
- (2) Replacement.
 - (a) Replace part and solder.
 - (b) Replace the receiver (paragraph 5.4b).
 - (c) Replace the case (paragraph 5.3b).

c. Relay Removal and Replacement

- (1) Removal.
 - (a) Remove the transmitter (paragraph 5.12a).
 - (b) Remove the three screws and rotate the bracket 90 degrees into the receiver area.
 - (c) Unsolder and tag the wire to the appropriate relay.
 - (d) Remove the four screws (9,18) that hold the relay shield (7) to the bracket (4).
 - (e) Remove the two nuts and washers (11,12) that hold the relay to the bracket.
- (2) Replacement.
 - (a) Replace relay and mount it to the bracket (4) using two nuts and washers (11,12).

- (b) Replace relay shield (7) to the bracket with four screws (9,18).
- (c) Resolder the previously tagged wires to the relay.
- (d) Mount the bracket (4) to the front panel using the three screws.
- (e) Replace transmitter (paragraph 5.12b).
- (f) Replace receiver (paragraph 5.4b).
- (g) Replace case (paragraph 5.3b).

5.23 Dessicant Removal and Replacement. (Refer to figures 5-2 and 5-18).

a. Access to Dessicant.

- (1) Remove case (paragraph 5.3a).

b. Dessicant Indicator.

- (1) A pink 30 circle indicates that the dessicant will soon require replacement.
- (2) A pink 40 circle indicates that the dessicant requires replacement.
- (3) A pink 50 circle indicates that the dessicant indicator requires replacement.
- (4) Overlap of the circles indicates that the equipment requires examination for humidity damage.

c. Dessicant Indicator Removal (figure 5-18).

- (1) Remove screw and washers.
- (2) Remove indicator holder (20).
- (3) Remove indicator (22) from holder.

d. Dessicant Indicator Replacement.

- (1) Replace indicator in holder.
- (2) Mount indicator and holder using the screw and washers.

e. Dessicant Removal (figure 5-2).

- (1) Remove screw and washers.
- (2) Remove dessicant holder (21).
- (3) Remove dessicant (20).

f. Dessicant Replacement.

- (1) Replace dessicant.
- (2) Mount dessicant holder over the dessicant using screw and washer.
- (3) Replace the case (paragraph 5.3b).

CHAPTER 6

TAR-224 RADIO MAINTENANCE

6.1 Scope

This section provides maintenance and troubleshooting procedures for various circuit operations of Radio Set TAR-224 units and sections. Procedures in this section require an oscilloscope (Tektronix Model 561 or equivalent) and a standard vacuum tube voltmeter having a 10 percent tolerance.

CAUTION

When using an ohmmeter, care should be taken since the voltage of the ohmmeter may cause damage to the transistors.

When troubleshooting the TAR-224, it is necessary to use the diagrams (figures 3-1 through 3-7) for the location of electrical parts and points of adjustment.

NOTE

All voltages, unless otherwise noted, are referenced to ground.

6.2 Receiver Maintenance

No troubleshooting of the tuner section (local) oscillator, RF Amplifier and Antenna Matching Network, will be given because of the inaccessibility of voltage and other measurement points in this section. Refer to figures 3-1 through 3-4 for location of the receiver electrical components.

6.3 IF Amplifier Section

Use table 6-1 when checking the equipment and when troubleshooting. This table contains the voltages that should be obtained, within reasonable limits, in the IF Amplifier section. Figure 6-1 shows component location.

TABLE 6-1. IF AMPLIFIER 1A3A7 DC VOLTAGES

(Conditions: +8V AGC on pin M of plug 1A3A7P1)

Transistor	V _E	V _B	V _C
Q1	0.7	1.3	3.0
Q2	0.8	1.3	3.0
Q3	1.8	2.5	3.4
Q4	1.5	1.8	3.4
Q5	2.2	2.4	1.9
Q6	1.7	2.2	3.5
Q7	2.2	2.3	1.8
Q8	0.4	1.0	3.6

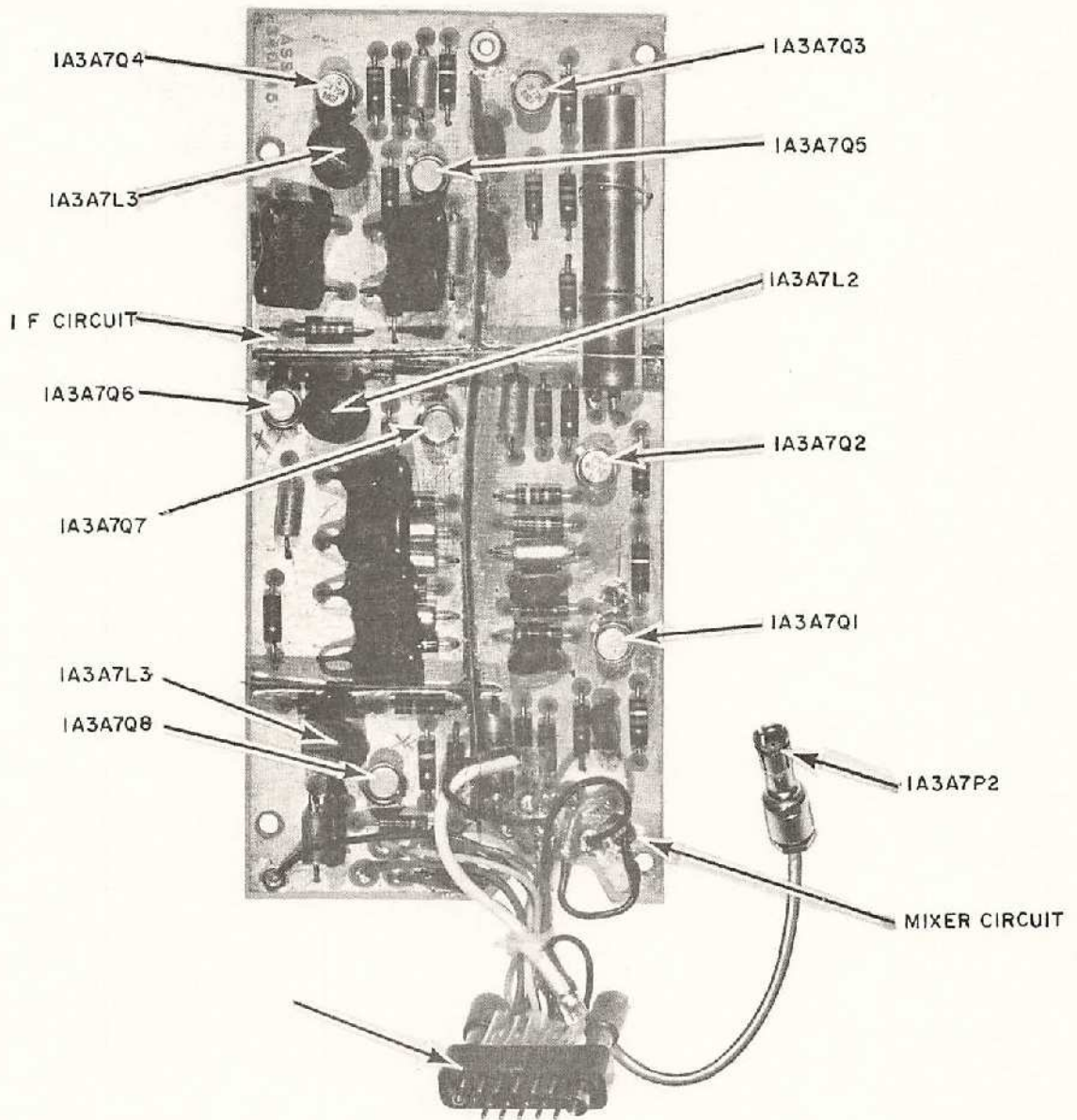

IF AND MIXER ASSEMBLY IA3A7

Figure 6-1. IF Amplifier Module

6.4 BFO and Calibrator Section

Use tables 6-2 and 6-3 when checking the equipment and when troubleshooting. Table 6-2 contains the voltages that should be obtained, within reasonable limits, from the calibrator board 1A3A6A1. Table 6-3 contains the voltages that should be obtained within reasonable limits, from the BFO board 1A3A6A2. Figure 4-3 shows component location for both the calibrator board and the BFO board.

TABLE 6-2. CALIBRATOR BOARD (1A3A6A1) DC VOLTAGES

(Condition: No signal input)

Transistor	V_E	V_B	V_C
Q1	2.6	3.2	7
Q2	2.5	2.6	7

TABLE 6-3. BFO BOARD (1A3A6A2) DC VOLTAGES

(Conditions: RCVR switch CAL position, no signal input)

Transistor	V_E	V_B	V_C
Q1	1.0	1.1	11.4
Q2	0.0	0.1	2.4

6.5 Audio and AGC Section

Use tables 6-4 and 6-5 when checking the equipment and when troubleshooting. Table 6-4 contains the voltages that should be obtained, within reasonable limits, from the audio board 1A3A8A1. Table 6-5 contains the voltages that should be obtained, within reasonable limits, from the transistors on the AGC board 1A3A8A2. Figure 6-2 shows component location for both audio and AGC boards.

TABLE 6-4. AUDIO AMPLIFIER BOARD (1A3A8A1) DC VOLTAGES

(Conditions: No signal input, RCVR switch CW position)

Transistor	V_E	V_B	V_C
Q1	3.4	3.5	10.8
Q2	2.8	3.3	6.3
Q3	1.9	2.5	5.4

TABLE 6-5. AGC BOARD (1A3A8A2) DC VOLTAGES

(Conditions: No signal input, RCVR switch CW position)

Transistor	V_E	V_B	V_C
Q1	0.0	0.1	10.7
Q2	0.0	0.01	9.4
Q3	0.1	0.0	10.7
Q4	1.9	2.2	7.6
Q5	3.0	3.2	10.5
Q6	1.0	2.4	15.6
Q7	1.0	1.7	10.5

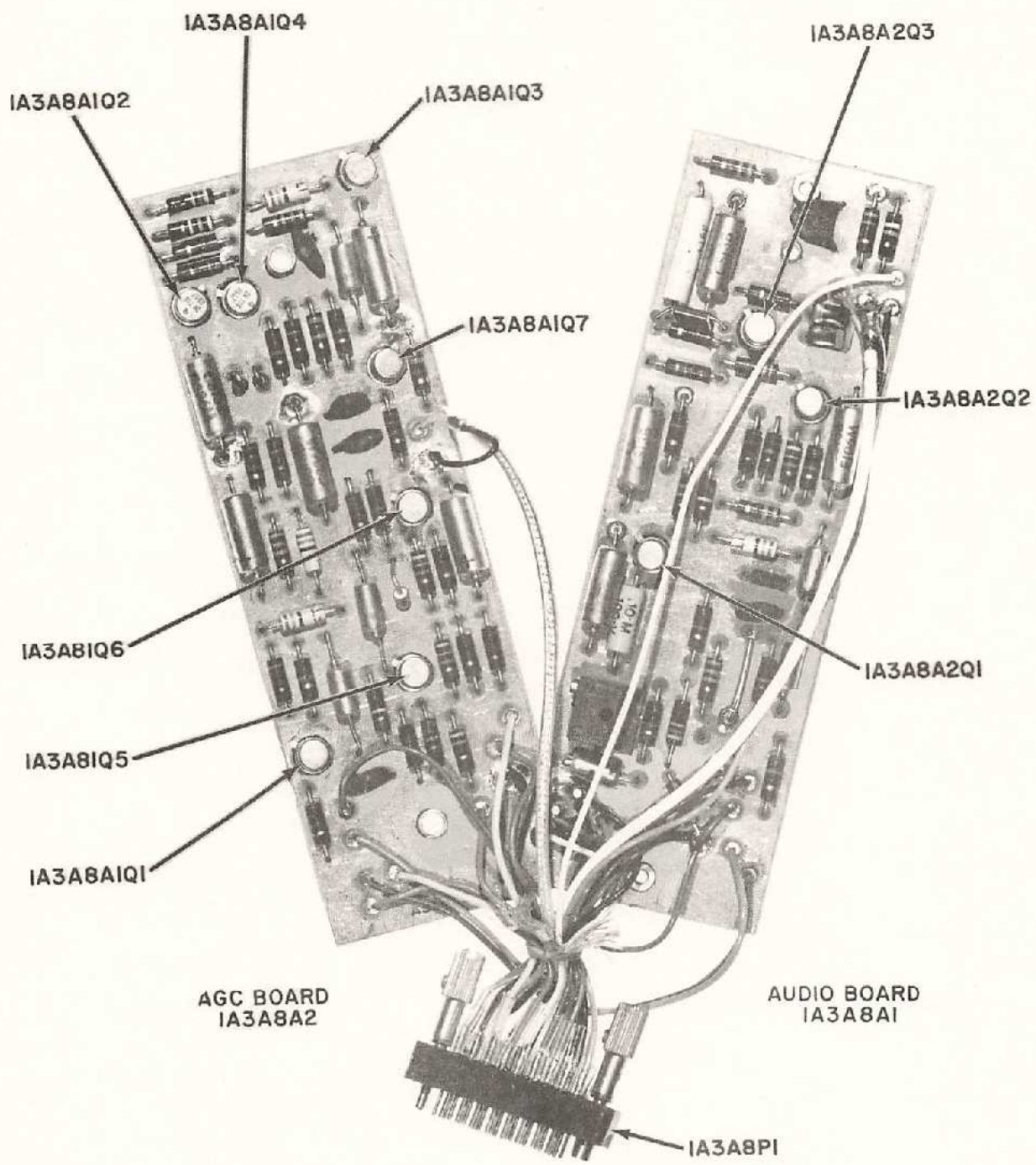

Figure 6-2. AGC Board and Audio Board

6.6 Transmitter Maintenance (Figure 6-3)

Refer to the following figures for location of electrical components. Figure 3-6 is a schematic diagram of the transmitter, figure 3-3 is a schematic diagram of the front panel, figure 3-7 is an interconnecting wiring diagram of the transmitter, and figure 3-5 is a block diagram of the transmitter. A list of troubles that may occur and their possible causes are listed in the following paragraphs.

- a. Matching network tunes to end; no power output, no meter deflection.

Probable cause:

- (1) Blown fuse 1A1F1 (figure 5-12).
- (2) Faulty motor relay 1A4K2 (39) (figure 5-14).
- (3) Faulty MIN or MAX switch 1A4A8S1 (48) or 1A4A8S2 (48) (figure 5-14).
- (4) Faulty motor control board no. 2 1A4A4 (figure 4-5).

- b. Matching network continuously searches when connected to 50-ohm load.

Probable cause: Faulty motor control board no. 1 1A4A3 (figure 4-5).

- c. Matching network will not initiate tune cycle.

Probable cause:

- (1) Faulty Zener diode 1A4A3CR1 on motor control board no. 1 1A4A3 (figure 4-5).
- (2) Broken lead between relay tune and motor control board no. 2 1A4A4 (figure 3-7).
- (3) No tune signal at pin 8 of 1A4A4.

- d. Power out on hand key normal, no power out on mike key.

Probable cause:

- (1) Bad microphone switch.
- (2) Broken wire.

- e. No modulation.

Probable cause:

- (1) Faulty modulator relay 1A4K1 (figure 5-13).
- (2) Faulty modulator transistor 1A4Q5 located under variable inductor turns indicator.

- f. No meter indication on tune up.

Probable cause:

- (1) Faulty meter 1A1M1 (figure 5-1).
- (2) Faulty resistor 1A4A1R5, 1A4A1R6, or 1A4A1R7.

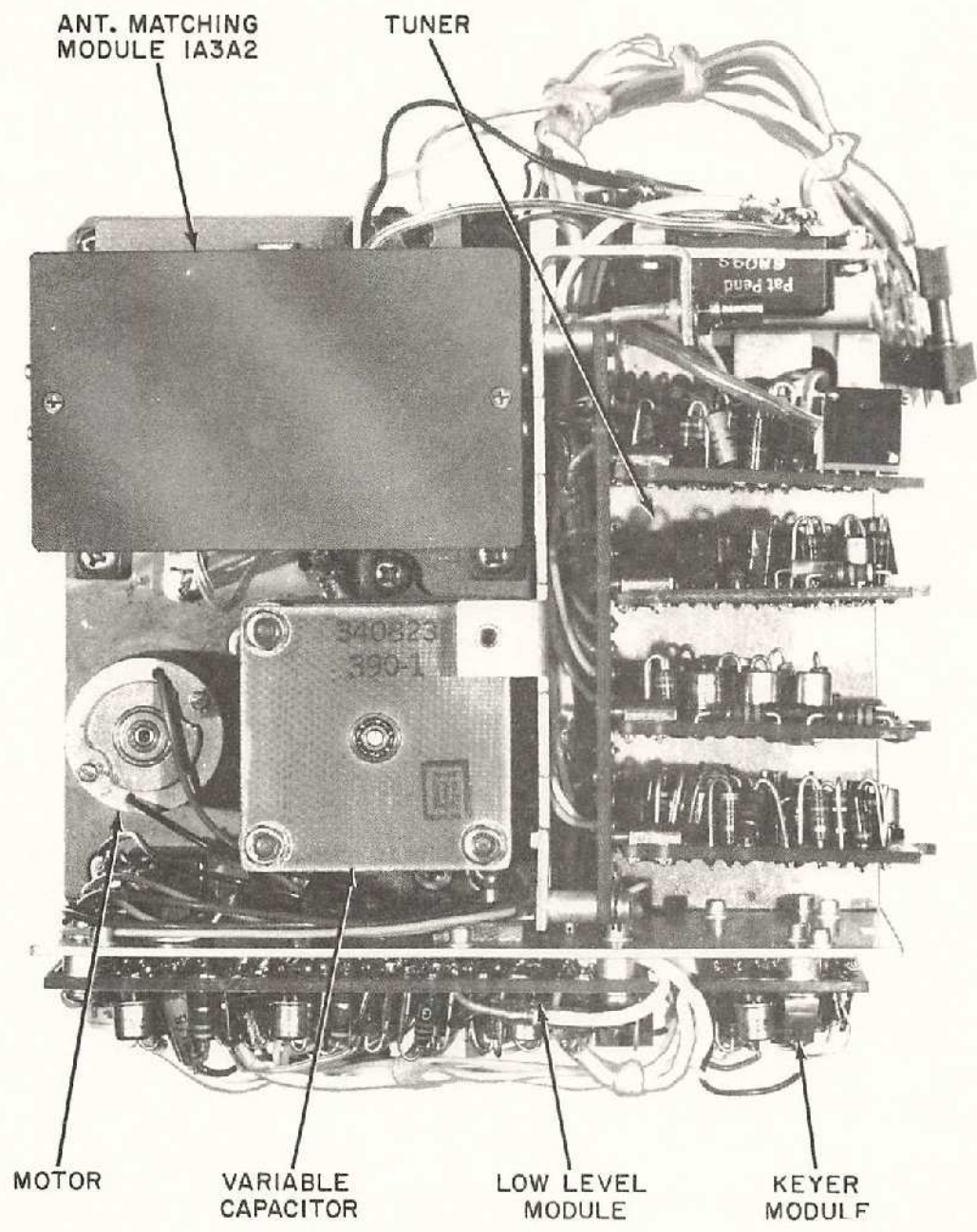

Figure 6-3. Antenna Matching Module Location

g. No sidetone.

Probable cause:

- (1) Faulty diode 1A4A6CR4 (figure 5-16).
- (2) Faulty transistor 1A4A6Q5 (figure 5-16).

h. No transmitter spot.

Probable cause:

- (1) Faulty switch 1A1S3-3.
- (2) Broken wire.

i. Over modulation or low peak power output.

Probable cause:

- (1) Faulty diode 1A4A5CR1 (figure 4-5).
- (2) Faulty transistor 1A4A5Q5 (figure 4-5).
- (3) Faulty component in associated circuitry of (1) and (2) above.

NOTE

The value of resistor 1A4A5R20 sets the carrier level in the modulation mode to between 5 to 7 watts. If this is not set properly (para 3.6.4), incorrect modulation could occur.

j. Squeal in transmitted signal.

Probable cause:

- (1) Faulty B+.
- (2) Faulty filter capacitor 1A4C1 or C4 in heat sink.
- (3) Faulty capacitor 1A4A7C14 (figure 5-16).

k. Low power output.

Probable cause:

- (1) Faulty final driver (figure 6-1).
- (2) Misalignment (paragraph 4.11 and 4.12).
- (3) Faulty plated through-hole on capacitor 1A4A7C19 (figure 5-16).
- (4) Faulty transmitter BAND switch (figure 5-1).
- (5) Low gain transistor in low level module.

l. Blown fuse.

Probable cause:

- (1) Shorted final transistor (figure 6-1); see step m.
- (2) B+ shorted to ground.
- (3) Transistor 1A4Q5 collector shorted to ground located under variable inductor turns indicator.

m. Shorted finals.

Probable cause:

- (1) Faulty transistors 1A4A7Q5, 1A4A7Q6, or 1A4A7Q11 in low level module (figure 5-16).
- (2) ALC lines crossed or not connected at all.
- (3) Open inductors 1A4A2L1, 1A4A2L2, 1A4A2L3, or 1A4A2L4 on the RF sampler (figure 4-5).

n. Prematurely dead battery.

Probable cause: Shorted battery lines on front panel.

CAUTION

If any short condition is noted on the battery lines, the battery should be removed immediately to prevent damage.

CHAPTER 7

CS-224 CIRCUIT DESCRIPTION AND MAINTENANCE

7.1 General

The CS-224 comprises a wideband Pierce type oscillator and a switched band of 30 CR-78/U crystals or 20 CR-78/U and 10 CR-89/U crystals. The frequency range of the CS-224 is 2 to 12 MHz.

7.2 Circuit Description

The schematic diagram for the CS-224 is shown in figure 7-1. Transistor Q1 is the oscillator operating as a common emitter amplifier with emitter degeneration by R3. Temperature compensated base bias is accomplished with R1, R2, and CR1. Inductor L1 makes the RF impedance of the bias circuit very high. Feedback is provided by the collector to ground capacitor C8 and the ground to base capacitor C7. The crystals (Y1 through Y30) and switches (S1 and S2) are arranged in a matrix fashion on a printed circuit board to minimize stray capacitance and inductance. Any one of the 30 crystals can be connected across the oscillator input terminals by setting S1 and S2 to the proper positions. Stray capacitance forms a part of the required parallel resonating capacitance. A means of trimming the capacitance associated with two of the rows to match that of the third is provided by C1, C2, and C3. The crystal selected by the switch positions performs as an inductor at resonance and is connected across the oscillator input. The crystal's resonating capacitance is made up of stray capacitance across the crystal terminals and the combination of C5 in series with the equivalent capacitance of the remainder of the circuit. Because of the large number of components and stray paths connected to the oscillator amplifier terminals, conditions for oscillation via stray reactance are met (with the crystal socket empty) at 400 kHz. Accordingly, C4 and L2 form a trap that decreases the gain of the oscillator in this undesired frequency range without degrading its 2 to 12 MHz performance. Inductor L3 provides d-c current for the collector of Q1 and base bias for Q2 via divider resistors R4 and R5. At the same time, a high RF impedance is presented at the collector of Q1 to keep the circuit Q high. Emitter follower Q2 is biased to allow a maximum signal amplitude of 10 volts peak-to-peak before severe distortion occurs. Transistor Q2 provides a low output impedance (less than 100 ohms), and is capable of driving capacitive loads because of the action of L4 in discharging the capacitance on the negative half cycle. The CS-224 is able to drive the RT-224 through at least 20 inches of RG-178/U coaxial cable without excessive signal loss or distortion. RF bypass is provided by C9.

7.3 Crystal Replacement

The CS-224 circuit board has pin sockets for the CR-89/U and CR-78/U crystals. To replace a crystal, use long nose pliers and pull it straight out of the circuit board and insert the new crystal in the reverse manner. If replacement of a crystal changes the total number of crystals in any or all the rows, it may be necessary to perform the alignment procedure (paragraph 7.4).

7.4 Oscillator Alignment

The oscillator alignment should be performed on all new units prior to installation in the RS-224. Also the oscillator should be aligned when the total number of crystals changes from the last adjustment or new crystals are installed.

a. Test Equipment Required. The following is a list of test equipment required to perform the alignment:

- (1) Digital frequency counter (Hewlett-Packard HP 524D, or equivalent)

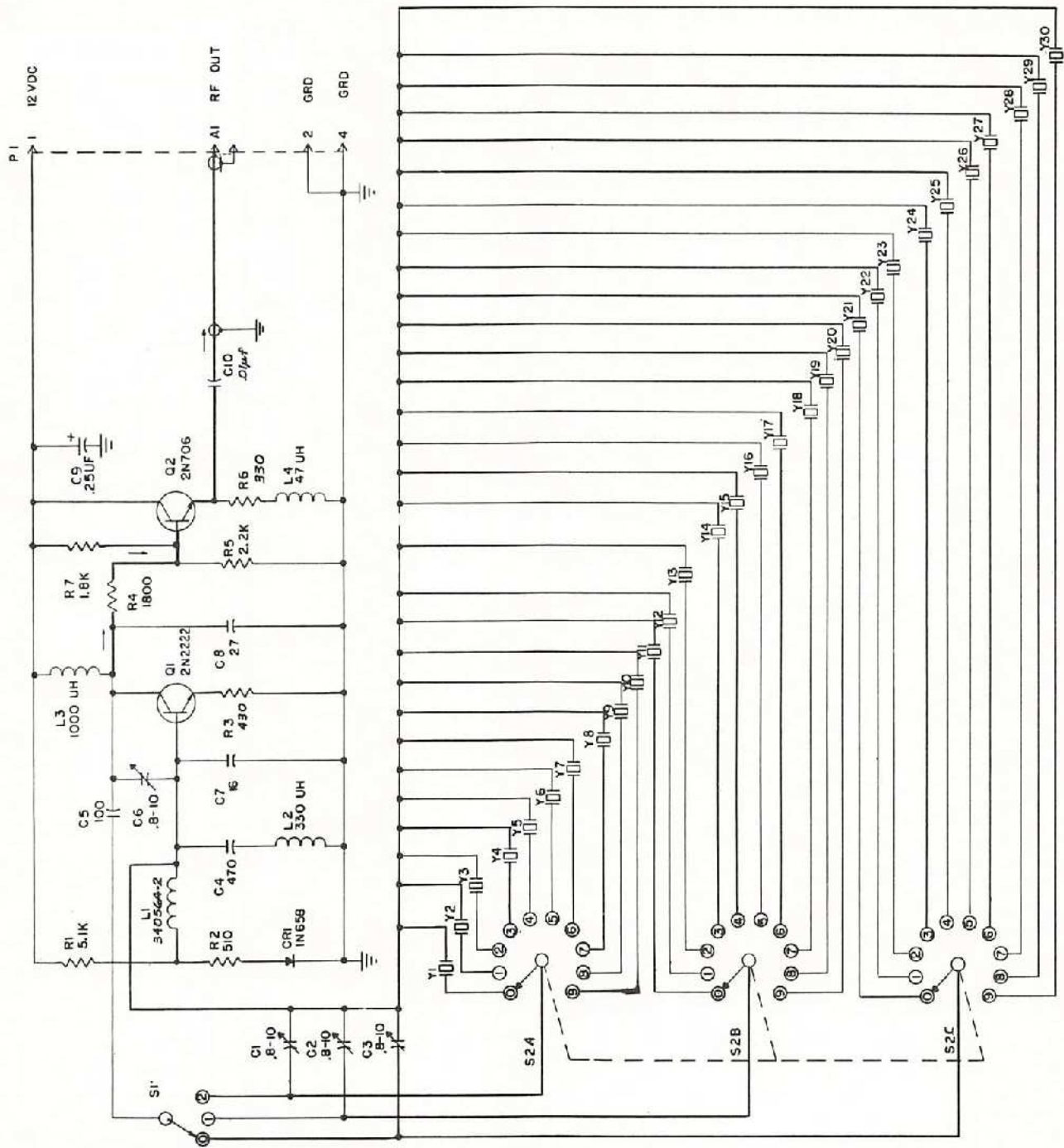

Figure 7-1. CS-224 Schematic Diagram

- (2) Plug In Unit (Hewlett-Packard HP 525A, or equivalent)
- (3) Oscilloscope (Tektronix 545, or equivalent)
- (4) 12-volt d-c power supply (Power Design 4005, or equivalent)

b. Initial Alignment. The initial alignment procedure is as follows:

- (1) Remove all crystals from their sockets. Remove round caps from variable capacitors C1, C2, and C3, and set to a fully counterclockwise position.
- (2) Position switches S1 and S2 in the 00 position; insert a 12 MHz crystal in the 00 socket.
- (3) Connect the power supply to the unit: +12 vdc to pin 1 of P1 and the ground to pin 4. Connect the oscilloscope to the output of the unit at R6. Connect the frequency counter to the vertical output of the oscilloscope.

NOTE

Do not connect the oscilloscope to the base or collector of Q2. The probe capacitance will change the frequency if connected in that manner.

- (4) Remove the round cap from C6 and adjust C3 and C6 to obtain a measured frequency of 12 MHz, \pm 600 cps.
- (5) Use the same 12 MHz crystal in the 10 and 20 position and adjust the associated trimmer capacitor so that all three positions (00, 10, 20) have the same measured frequency, \pm 120 cps, not to exceed 12 MHz \pm 600 cps. Capacitor C2 trims position 10 and capacitor C1 trims position 20.
- (6) Disconnect the power supply and insert the desired crystals. If all 30 crystal sockets are not used, be sure that each of the three rows of sockets contains the same number of crystals.

c. Final Alignment

- (1) With all crystals inserted as instructed in paragraph 7.4a(6), reconnect the power supply.
- (2) Replace the crystal in position 00 with a 12 MHz crystal, and position selector switches, S1 and S2, to 00.
- (3) Adjust C6 so that the measured frequency is 12 MHz, \pm 600 cps. Adjust C3 to the minimum setting to obtain the required frequency.
- (4) Check the alignment of positions 10 and 20 using the same 12 MHz crystal. A slight adjustment of C3, C2, and C1 may be necessary to ensure all three bands are within \pm 120 cps of each other not to exceed 12 MHz \pm 600 cps. Do not position C2 and C1 any higher than the minimum to obtain the desired results.
- (5) Position the selector switches in the 00 position.
- (6) Alternately place a 12 MHz and 2 MHz crystal in the 00 socket and adjust C6 so that the measured 2 MHz frequency divided by 2 MHz is equal to the measured 12 MHz frequency divided by 12 MHz. Example: If the measured 2 MHz frequency is 2 MHz plus 10 cps, then the measured 12 MHz frequency should be 12 MHz plus 120 cps. Be sure that the requirements of steps (3) and (4) are met.

- (7) Disconnect the test equipment and replace the round caps on the variable capacitors and record the crystal alignments on the chart.

7.5 Maintenance

a. If the oscillator functions, but one of the crystal positions does not result in oscillation, the following procedure should be performed:

- (1) Test the crystal in several other sockets; if the unit still does not oscillate, the crystal is probably defective.
- (2) If the CS-224 operates with the suspected crystal in other sockets, check the faulty position for bad socket pins, broken solder connections, or dirty selector switch contacts.

b. If the CS-224 does not function at all, check the transistor terminal voltages as shown in Table 7-1.

TABLE 7-1. CS-224 TRANSISTOR TERMINAL VOLTAGES

Transistor	V _C	V _B	V _E
Q1	12	1.7	1.1
Q2	12	6.3	5.7

If the measured d-c voltages are not within ± 20 percent of the above values, remove the transistor involved and measure the base voltage again. If the base voltage is not as indicated above, any of the base circuitry components may be defective. Disconnect the power supply and use an ohmmeter to check the circuit.

c. It is possible the crystal matrix connection across the oscillator input terminals is faulty. With the power supply disconnected, use an ohmmeter to check continuity from the switch side of C5 to the crystal socket pin selected by the switches. Then check continuity from the crystal socket common pin to the base of transistor Q1.

7.6 CS-224 Disassembly and Assembly

Most repairs can be accomplished on the CS-224 by performing the following procedures in the order given:

a. Board and Front Panel Assembly Removal

- (1) Remove four mounting screws and lift the case cover clear of the case (figure 7-2).
- (2) Detach the case ground wire at the rear of the case.
- (3) Remove the four standoff-mounting screws that secure the board to the case.
- (4) Remove the four front panel mounting screws that secure the front panel to the case.
- (5) The board and front panel assembly can be lifted from the case and tilted up for maintenance.

b. Front Panel Removal

- (1) Remove the ground wire at the rear of the front panel.
- (2) Remove the switch knobs, mounting nuts, and spacers.

ITEM NO.	PART NO.	DESCRIPTION
1	340562	CHASSIS
2	340563-1	PANEL, FRONT
3	340566	COVER ASSEMBLY
4	340569	PC BOARD ASSEMBLY
5	J31-30375CFLH	STANDOFF
6	J39-1F0656CMCLH	STANDOFF
7	23MS24693-S2	SCREW
8	340772-1	SCREW, SEAL
9	DEM 5WIP	PLUG
10	MS51957-12	SCREW
11	MS51957-1	SCREW
12	MS35337-77	LOCKWASHER, SPLIT
13	1102-01	LOCKWASHER
14	MS35337-78	LOCKWASHER
15	MS35649-244	HEX NUT
16	MS35335-57	LOCKWASHER
17	340593	KNOB
18	DM-53741-5000	CONNECTOR, COAX
19	MS51963-9	SET SCREW

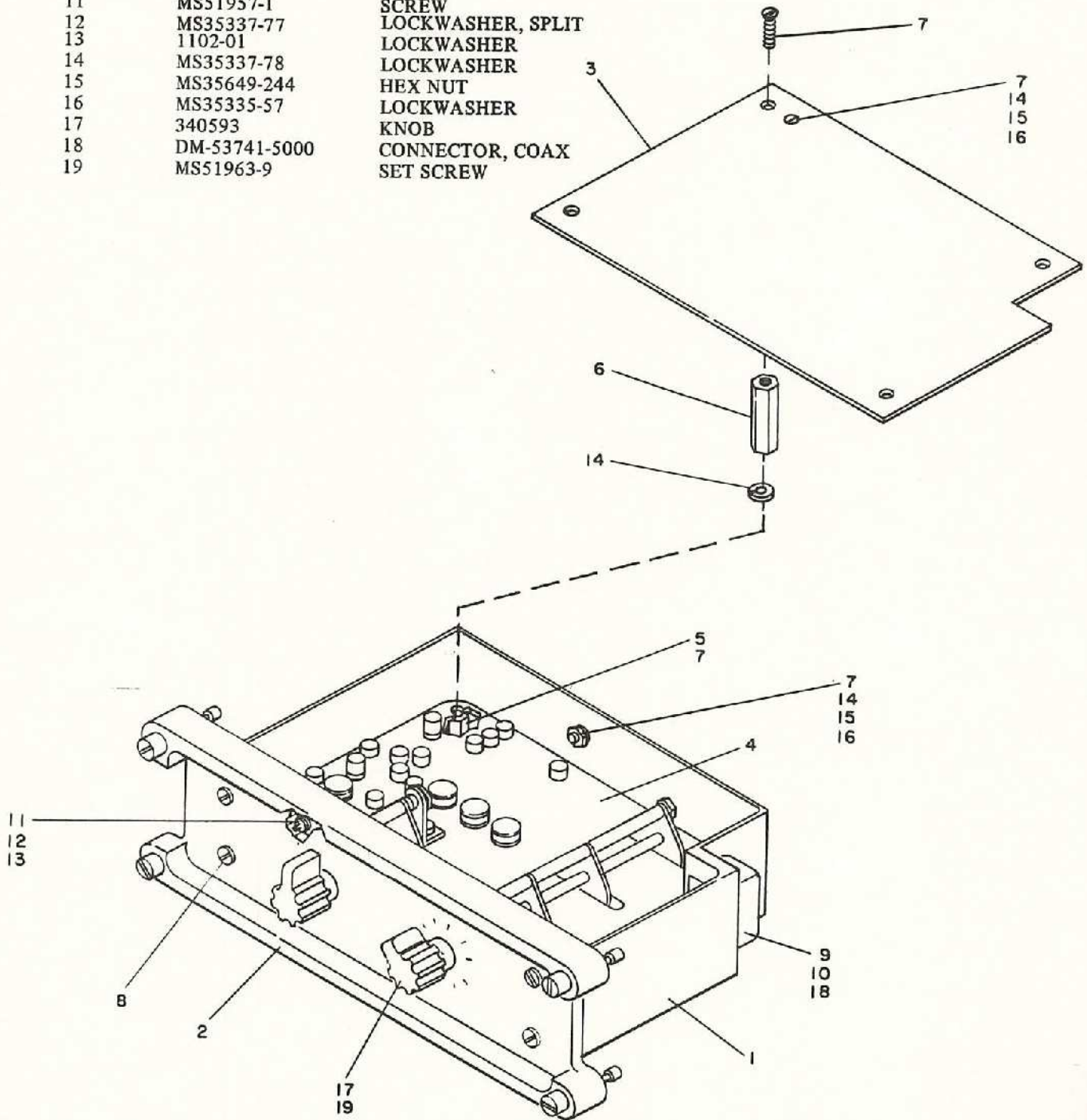

Figure 7-2. CS-224 Crystal Selector

(3) Remove the front panel from the circuit board.

c. Connector P1 Removal

(1) Tilt the board in the chassis so the solder connections at P1 are accessible.

CAUTION

Do not put any unnecessary strain on wires connected between the board and connector.

(2) Unsolder and tag the five wires connected to the plug (P1).

d. Board Installation in Case

(1) Place the board in the chassis with the tagged wires accessible.

(2) Solder the tagged wires to the connector.

(3) Position the board properly in the case.

e. Front Panel Installation

(1) Carefully place the front panel over the switch shafts and replace the spacers, washers, and nuts.

(2) Connect the ground wire to the rear of the front panel.

f. Board and Front Panel Assembly Installation

(1) Replace the four front panel mounting screws to secure the front panel to the case.

(2) Replace the case ground wire at the rear of the case.

(3) Replace the four standoff-mounting screws to secure the board to the case.

(4) Place the case cover in position and replace the four screws to secure the cover to the case.

CHAPTER 8

PARTS LISTS AND LISTS OF MANUFACTURERS

8.1 Parts List

Table 8-1 lists the assemblies, subassemblies and major units comprising Radio Set TAR-224. A parts list of electrical parts and components are given in tables 8-2 through 8-5. These tables reference the part symbol as used on the schematics, the part nomenclature, and the manufacturer's catalog number or the part number. In instances where no manufacturer is identified, the part may be obtained from any qualified parts manufacturer.

8.2 List of Manufacturers

A list of manufacturers of parts for Radio Set TAR-224 are given below.

MANUFACTURER	CODE	MANUFACTURER	CODE
Aerovox Corporation 740 Belleville Avenue New Bedford, Massachusetts 02741	71471	Bourns Incorporated 1200 Columbia Avenue Riverside, California 92507	80294
Allen Bradley 1201 South 2nd Street Milwaukee, Wisconsin 53204	01121	Capewell Mfg. Company 60 Governor Street Hartford, Conn. 06102	71304
Allied Control Co., Inc. 2 East End Avenue New York, New York 10021	70309	Centralab Division Globe-Union Inc. 932 East Keefe Avenue Milwaukee, Wisconsin 53212	71590
Amphenol Corp. RF. DIV 33 E. Franklin Street Danbury Connecticut 06810	74868	Clevite Corporation 17000 St. Clair Avenue Cleveland, Ohio 44110	06743
Arco Electronics, Inc. Community Drive Great Neck, New York 11022	84171	Components Incorporated Smith Street Biddeford, Maine 04005	17554
Arrow Hart & Hageman Electric Co. 103 Hawthorn Street Hartford, Connecticut 06106	04009	Continental Connector Corporation 34-63 56th Street Woodside, New York 11377	95238
Avco Electronics Division 2630 Glendale-Milford Road Cincinnati, Ohio 45241	80045	Cornell-Dubilier Corporation MICA Division 289 West River Providence, Rhode Island 02904	09022
Bliley Electric Company 2545 W Grandview Blvd Erie, Pa. 16512	71034	Cornell-Dubilier Electric Corporation 50 Paris St. Newark, N.J.	14655

MANUFACTURER	CODE	MANUFACTURER	CODE
EBY Hugh H. Inc. 4701 Germantown Avenue Philadelphia, Pa. 19144	72825	Metals and Controls Inc. Control Products Group 300 N. Main Versailles, Ky. 40383	14859
Electro Motive Mfg. Company The South Part & John Streets Willimatic, Conn. 06226	72136	Metals and Controls, Inc. Metallurgical Prod. Group 34 Forest Street Attleboro, Mass. 02703	73803
Erie Technological Products Inc. 644 West 12th Street Erie, Pennsylvania 16512	72982	Miniature Electronics Components Corp. 600 South Street Holbrook, Mass. 02343	07479
Fairchild Camera and Instrument Corp. Semiconductor Division 313 Frontage Rd. Mountain View, Calif.	07263	Motorola Semiconductor Prod., Inc. 5005 East McDowell Road Phoenix, Ariz. 85008	04713
Fairchild Semiconductor Division Transducer Plant Mountain View, California	17803	Nytronics Incorporated 550 Springfield Avenue Berkeley Heights, New Jersey 07922	72259
Ferrocube Corp. of America Mt. Marion Road Saugerties, New York 12477	02114	Ohmtronics Mfg. Inc. 2406 Leavenworth Street Omaha, Nebr. 68105	12463
General Electric Company Speciality Control Department P.O. Box 812 Waynesboro, Va. 22980	01526	Piezoelectric Div. Clevite Corp. 232 Forbes Rd. Bedford, Ohio	06961
Honeywell, Inc. Micro Switch Division Chicago & Spring Streets Freeport, Illinois 61032	91929	Potomac Rubber Company Inc. 24 Kennedy NW Washington, D.C. 20011	83104
Indiana General Corp. Electronics Division Keasby, N.J.	72656	San Fernando Elec. Mfg. Company San Fernando, Calif.	96733
ITT Cannon Electric Inc. 3208 Humbolt St. Los Angeles, Calif. 90081	71468	H.H. Smith Inc. 812 Snediker Avenue Brooklyn, New York 11207	83330
JFD Electronics Company 15th at 62nd Street Brooklyn, New York 11219	73899	Spectrol Electronics Corp. 17070 East Gale Avenue City of Industry, Calif. 91745	02111
Keystone Carbon Co., Inc. 1935 State Street St. Marys, Pennsylvania 15857	75263	Sperry Semiconductor Div. Sperry Rand Corp. 380 Main St. Norwalk, Conn. 06850	07713
Los Angeles Miniature Products, Inc. 17000 S. Western Avenue Gardena, California 90247	17537	Sprague Electric Co. Marshal Street North Adams, Massachusetts 01247	56289

MANUFACTURER	CODE	MANUFACTURER	CODE
Texas Instruments Inc. Semiconductor Components Division 13500 North Central Expressway Dallas, Texas 75231	01295	Westinghouse Air Brake Company Union Switch and Signal Division 1789 Braddock Avenue Pittsburgh, Pa. 15218	61775
Union Carbide Corp. Electronics Division 270 Park Avenue New York, New York	05397	Westinghouse Electric Corp. Semiconductor Dept. Youngwood, Pennsylvania 15697	05277
Unitrode Corp. 580 Pleasant Street Watertown, Massachusetts 02172	12969	Weston Instruments, Inc. Archbald, Pa. 18403	94271
Vitramon, Incorporated Box 544 Bridgepoint, Conn. 06601	95275	Winchester Electronics Main St. & Hillside Avenue Oakville, Conn.	81312
		Witte Engine Works Oilwell Division United States Steel Corp. 1600 Oakland Avenue Kansas City, Missouri 64126	97947

A cross reference of code to name of manufacturer of parts for Radio Set TAR-224 is given below:

CODE	MANUFACTURER
01121	Allen Bradley
01295	Texas Instruments, Inc.
01526	General Electric Co.
02111	Spectrol Electronics Corp.
02114	Ferroxcube Corp of America
04009	Arrow Hart & Hageman Electric Co.
04713	Motorola Semiconductor Products, Inc.
05277	Westinghouse Electric Corp. (Semiconductor)
05397	Union Carbide Corp. Electronics Division
06743	Clevite Corporation
06961	Piezoelectric Div., Clevite Corp.
07263	Fairchild Camera and Instrument Corp.
07479	Miniature Electronics Components Corporation
07713	Sperry Semiconductor Div., Sperry Rand Corp.
09022	Cornell-Dubilier Corporation
12463	Ohmtronics Mfg. Corp.
12969	Unitrode Corporation
14655	Cornell-Dubilier Electric Corp.
14859	Metals and Controls Inc.
17537	Los Angeles Miniature Products Inc.
17554	Components Incorporated
17803	Fairchild
56289	Sprague Electric Company
61775	Westinghouse Air Brake Company
70309	Allied Control Co., Inc.
71034	Bliley Electric Co.
71304	Capewell Mfg. Co.
71468	ITT Cannon Electric Inc.

CODE	MANUFACTURER
71471	Aerovox Corporation
71590	Centralab Division
72136	Electro Motive Mfg. Co.
72259	Nytronics, Inc.
72656	Indiana General Corp.
72825	EBY Hugh H. Inc.
72982	Erie Technological Products, Inc.
73803	Metals and Controls, Inc.
73899	JFD Electronics Company
74868	Amphenol Corp. R.F. Div.
75263	Keystone Carbon Co., Inc.
80045	Avco Electronics Division
80294	Bourns, Inc.
81312	Winchester Electronics
83104	Potomac Rubber Co., Inc.
83330	H.H. Smith Inc.
84171	Arco Electronics, Inc.
91929	Honeywell Inc.
94271	Weston Instruments, Inc.
95238	Continental Connector Corp.
95275	Vitramon Inc.
96733	San Fernando Elec. Mfg. Co.
97947	Witte Engine Works

TABLE 8-1. LIST OF UNITS IN RADIO SET TAR-224

Ref. Des.	Assembly	No. Per System	Drawing No.
1A1	Front Panel	1	340603-1
1A1A1	Battery Protection Circuit	1	340450
1A1A2	VFO Coupler	1	340909
1A1A3	Relay Bracket Assy	1	340603
1A2	Crystal Selector	1	340569
1A3	Receiver	1	340601
1A3A1	Interwiring Board Assy	1	340844
1A3A2	Ant. Match. Network	1	340836
1A3A3	RF Amp.	1	340835
1A3A4	Local Oscillator	1	340834
1A3A5	Parent Board, Tuner	1	340843
1A3A6	BFO & CAL	2	340847
1A3A6A1	CAL. Board	1	340945
1A3A6A2	BFO Board	1	340946
1A3A7	IF AMP & Mixer	1	340845
1A3A8	Audio Amp.	1	340846
1A3A8A1	Audio Board	1	340948
1A3A8A2	AGC Amp. Board	1	340949
1A4	Transmitter	1	340602
1A4A1	Ant. Tuning Module	1	340825
1A4A2	RF Sampler	1	340759
1A4A3	Motor Board No. 1	1	340830
1A4A4	Motor Board No. 2	1	340831
1A4A5	Modulator	1	340764
1A4A6	Keying Circuit	1	340757
1A4A7	Low Level Module	1	340747
1A4A8	Driver Final Assy	1	340829
1A5	Case, Assy	1	340947
1BT1	Battery, Type 224	1	340583

TABLE 8-2. FRONT PANEL 1A1 (DWG NO. 340603) AND SUBASSEMBLIES 1A1A1 THRU 1A1A3

Ref. Des.	Name and Description	No. Per Unit	Part Number	Mfr.
1A1A1	Battery Protection Ckt.	1	340450	80045
1A1A2	VFO Coupler Assembly	1	340909	80045
1A1A3	Relay Assembly	1	340944 1	80045
C1,C2 C3,C4,C5, C6 C7	Cap, Fxd, Elec-Tantalum 0.02 uf, ± 5% 50 VDC (Working Volt)	6	5835-000Y5U0203Z	72982
	Cap, Fxd, Mdelec; 2200 pf, ± 5%, 300 VDC (Working Volt)	1	SCDM19D222J0500	72136
CR4,CR10	Diode	2	4813-04	80045
CR8	Diode	1	UT261	12969
CR9	Diode	1	1N3469	
DS2	Lamp, Incandescent; 13V, 60 MA, 15 CP	1	66	17537
J1	Conn, Rcpt, Elec; 6 Contacts, Male Type Contacts	1	350425	80045
J2	Conn, Rcpt, Elec; 6 contacts, Male Type Contacts	1	350426	80045
J3	Conn, Rcpt, Elec; 20 Contacts, Female Type Contacts	1	MM20-22SDGFS-50	95238
J4	Conn, Rcpt, Elec; 29 Contacts, Female Type Contacts	1	MM29-22SDGF	95238
J5	Conn, Rcpt, Elec; 3 Contacts, Male Type Contacts	1	BT07C8-3P	09922
J7	Conn, Rcpt, Elec; 5 Contacts, Female Type Contacts	1	DEMF5W1S	71468
J8,J9	Post Spring-Ant. Terminal Plug, Banana-RF Output	2 2	7841 103	72825 83330
L1	Coil, RF; 0.75 uh, ± 20%, 5 MHz	1	VK20010/3B	02114
L2	Coil, RF; 100 uh, ± 10%, 13 MHz	1	1802-01-09	80045
M1	Meter, Arbitrary Scale- 12 VDC for full scale Deflection, 0.06 Amp.	1	340968	MIL-M- 17275
P1	Conn, RF; 1 contact	1	UG-1460U	
P2	Conn, Rcpt, Elec; 20 Contacts, Male Type Contacts	1	SMS-20-PGD	95238
R5	Resistor, Var; 5K, ±10%, 1/2 W, W/SPST Switch	1	GS1T040P502UA	01121
R6	Res, Fxd, Comp; 2.4K, ±5%, 1/4 W	1	RC07GF242J	MIL-R-11
R7	Res, Fxd, Comp; 33K, ± 5%, 1/4 W	1	RC07GF333J	MIL-R-11

TABLE 8-2. FRONT PANEL 1A1 (DWG NO. 340603) AND SUBASSEMBLIES 1A1A1 THRU 1A1A3 (Cont)

Ref. Des.	Name and Description	No. Per Unit	Part Number	Mfr.
R8	Resistor, Var; 5K, ± 10%, 1/2 W	1	GA2T040P502AA	01121
R9	Res, Fxd, Comp; 150 Ohm, ± 5%, 1/4 W	1	RC07GF151J	MIL-R-11
R10	Resistor, Var; 50K, ± 10%, 1/2 W	1	GA2T040P503UA	01121
R11	Res, Fxd, Comp; 18K, ± 5%, 1/4 W	1	RC07GF183J	MIL-R-11
S1,S6	Switch, Push-Button; SPDT, 115 VAC, 1 Amp.	2	PM3	04009
S2	Switch, Rotary - 2 Section, 5 Pole, 3 Pos.	1	340380	80045
S3	Switch, Rotary - 3 Section, 6 Pole, 4 Pos.	1	340741	80045
S5	Switch, Pushbutton; DPDT, 115 VAC, 1 Amp.	1	PM6	04009
1A1A1 BATTERY PROTECTION CIRCUIT (DWG. NO. 340450)				
C1	Cap, Fxd, Elec-Tantalum; 22 uf, ± 20%, 15 VDC (Working Voltage)	1	1502-03-4	80045
CR1,CR2, CR3,CR5, CR6	Diode	5	4813-04	80045
CR4	Diode, Zener	1	1/4 M8.2Z5	04713
Q1	Transistor	1	2N3249	
Q2	Transistor	1	2N956	
R1	Res, Fxd, Comp; 13K ± 5%, 1/4 W	1	RC07GF133J	MIL-R-11
R2	Res, Fxd, Comp; 510 ohm, ± 5%, 1/4 W	1	RC07GF511J	MIL-R-11
R3	Res, Fxd, Comp; 3.3K, ± 5%, 1/4 W	1	RC07GF332J	MIL-R-11
R4	Res, Fxd, Comp; 3K, ± 5%, 1/4 W	1	RC07GF302J	MIL-R-11
R5	Res, Fxd, Comp; 6.2K, ± 5%, 1/4 W	1	RC07GF622J	MIL-R-11

TABLE 8-2. FRONT PANEL 1A1 (DWG NO. 340603) AND SUBASSEMBLIES 1A1A1 THRU 1A1A3 (Cont)

Ref. Des.	Name and Description	No. Per Unit	Part Number	Mfr.
1A1A2 VFO COUPLER (DWG NO. 340909)				
C1,C2	Cap, Fxd, Cdelec; 10 uf, ± 20%, 100 VDC (Working Volt)	2	WM14BX104M	96733
C3	Cap, Fxd, Mdelec; 200 pf, ± 5%, 500 VDC (Working Volt)	1	SCDM10F201J0100	84171
L1	Coil, RF; Cp = -20 pf ±10% and Rp = 6K Min. @ 2 MHz, Cp = +0.8 pf ±10% and Rp = 10K Min @ 12 MHz	1	340096	80045
L2	Coil, RF; Cp = ±1.0 pf and Rp = 25K Min. @ 2 MHz, Cp = +4 pf Max and Rp = 25K Min @ 12 MHz	1	340097	80045
P1	Conn, Rept, Elec, Single contact, female	1	UG1461/U	
R1	Res, Fxd, Comp; 150 ohm, ± 5%, 1/4 W	1	RC07GF151J	MIL-R-11
R2	Res, Fxd, Comp; 390 ohm, ± 5%, 1/4 W	1	RC07GF391J	MIL-R-11
1A1A3 RELAY BRACKET ASSEMBLY (DWG. NO. 340944)				
CR2,CR6, CR7	Diode	3	4813-04	80045
CR1, CR3	Diode	2	1N5401	05277
CR5	Diode, Zener	1	1N960B	
F1	Fuse; 8 Amp, 12 VDC	1	340849	80045
K1	Relay, Armature; DPDT, 12 VDC Coil		3SBK5-10-2D1	01526
K2	Relay, Armature; Latching Type DPDT, 12 VDC Coil	1	3SAM6-10-4F2	01526
R3	Res, Fxd, Comp; 4.3K, ± 5%, 1/4 W	1	RC07GF432J	MIL-R-11
R4	Res, Fxd, Comp; 33 ohm, ± 5%, 1/4 W	1	RC07GF330J	MIL-R-11

TABLE 8-3. CRYSTAL SELECTOR (CS-224) 1A2 (DWG. NO. 340569)

Ref. Des.	Name And Description	No. Per Unit	Part Number	Mfr.
C1,C2	Cap, Var, Air Dielec; 0.8 to 10 pf, 250 VDC (Working Volt)	2	VAM010M	73899
C3,C6	Cap, Var, Air Dielec; 0.8 to 10 pf, 250 VDC (Working Volt)	2	VAM010W	73899
C4	Cap, Fxd, Gdelec; 470 pf, $\pm 5\%$, 500 VDC (Working Volt)	1	CY15C471J	MIL-C-11272
C5	Cap, Fxd, Gdelec; 100 pf, $\pm 5\%$, 500 VDC (Working Volt)	1	CY12C101J	MIL-C-11272
C7	Cap, Fxd, Gdelec; 16 pf, $\pm 5\%$, 500 VDC (Working Volt)	1	CY12C160J	MIL-C-11272
C8	Cap, Fxd, Gdelec; 27 pf, $\pm 5\%$, 500 VDC (Working Volt)	1	CY12C270J	MIL-C-11272
C9	Cap, Fxd, Elec; 0.33 uf, $\pm 20\%$, 20 VDC (Working Volt)	1	1502-01-16	80045
C10	Cap, Fxd, Cdelec; 0.01 uf, $\pm 20\%$, 100 VDC (Working Volt)	1	1501-19-75	80045
CR1	Diode	1	1N658	
L1	Inductor, Toroid Special	1	340564-2	80045
L2	Coil, RF; 330 uh, Q = 26 Min.	1	1802-01-12	80045
L3	Coil, RF; 1000 uh, $\pm 10\%$, 790 kHz, Q = 28 Min.	1	1802-01-14	80045
L4	Coil, RF; 47 uh, $\pm 10\%$, 2.5 MHz, Q = 45 Min.	1	1802-01-65	80045
Q1	Transistor	1	2N2222	
Q2	Transistor	1	2N706	
R1	Res, Fxd, Comp; 5.1K, $\pm 5\%$, 1/4 W	1	RC07GF512J	MIL-R-11
R2	Res, Fxd, Comp; 510 ohm, $\pm 5\%$, 1/4 W	1	RC07GF511J	MIL-R-11
R3	Res, Fxd, Comp; 430 ohm, $\pm 5\%$, 1/4 W	1	RC07GF431J	MIL-R-11
R4,R7	Res, Fxd, Comp; 1.8K, $\pm 5\%$, 1/4 W	2	RC07GF182J	MIL-R-11
R5	Res, Fxd, Comp. 2.2K, $\pm 5\%$, 1/4 W	1	RC07GF222J	MIL-R-11
R6	Res, Fxd, Comp; 330 ohm, $\pm 5\%$, 1/4 W	1	RC07GF331J	MIL-R-11

TABLE 8-4. RECEIVER 1A3 (DWG. NO. 340601) AND SUBASSEMBLIES 1A3A1 THRU 1A3A8

Ref. Des.	Name And Description	No. Per Unit	Part Number	Mfr.
1A3A1	Rcvr, Interwiring Brd.	1	340844	80045
1A3A2	Ant. Match. Assembly	1	340836	80045
1A3A3	RF Amp. Assembly	1	340835	80045
1A3A4	Local Osc. Assembly	1	340834	80045
1A3A5	Tuner Parent Brd. Rcvr. Chassis	1	340843	80045
1A3A6	BFO and Calib. Assembly	1	340847	80045
1A3A7	Mixer, IF Assembly	1	340845	80045
1A3A8	Audio Assembly	1	340846	80045
C1	Cap; 3 Section, Sect. 1, 0 to 75.38 pf, Sect. 2 and 30 to 78.85 pf, 170 deg. max. rotation	1	340714	80045
J1,J2	Conn, Rcpt, Elec; 14 Contacts, Female Type Contacts	2	MM14-22SGDFS50	95238
J3	Conn, Rcpt, Elec; Coaxial	1	27-36	74868
J4	Conn, Rcpt, Elec; 26 Contacts, Female Type Contacts	1	MM26-22SGDFS50	95238
P1	Connector, Front Panel Jct 29 Contacts, Male Type Contacts	1	MM29-22PDGF	95238
1A3A1 INTERWIRING BOARD (DWG. NO. 340844)				
C1	Cap, Fxd, Elec-Tantalum; 10 uf, $\pm 20\%$, 20 VDC (Working Volts)	1	CS13BE106M	MIL-C-26655
Q1	Transistor	1	2N3250	
R1,R2	Res, Fxd, Comp; 100 ohm, $\pm 5\%$, 1/4 W	2	RC07GF101J	MIL-R-11
R3	Res, Fxd, Comp; 82K, $\pm 5\%$, 1/4 W	1	RC07GF823J	MIL-R-11
R4	Resistor, Variable; 50K, $\pm 5\%$, 1 W	1	3280P1-503	80294
R5	Res, Fxd, Comp; 100K, $\pm 5\%$, 1/4 W	1	RC07GF104J	MIL-R-11
R6	Res, Fxd, Comp; 27K, $\pm 5\%$, 1/4 W	1	RC07GF273J	MIL-R-11
S1	Switch, Sensitive, SPDT	1	1SX1-T	91929

TABLE 8-4. RECEIVER 1A3 (DWG NO. 340601) AND SUBASSEMBLIES 1A3A1 THRU 1A3A8 (Cont)

Ref. Des.	Name and Description	No. Per Unit	Part Number	Mfr.
1A3A2 ANTENNA MATCHING NETWORK (DWG. NO. 340836)				
A1	Ant. Match. Assy. Ckt. Bd.	1	340736-1	80045
C1,C4, C5	Cap, Fxd, Cdelec; 0.05 uf, ± 20%, 12 VDC (Working Volt)	3	5635-000Y5F0503M	72982
C2	Cap, Fxd, Cdelec; 0.05 uf, +80% To -20%, 25 VDC (Working Volt)	1	5855-000Y55U0503Z	72982
L1	Coil, RF, 33 uh, ± 10%, 2.5 MHz, Q = 45 Min.	1	1802-01-07	80045
Q1	Transistor	1	340197	80045
Q2	Transistor	1	2N2222	
R1,R9	Res, Fxd, Comp; 39K, ± 5%, 1/4 W	2	RC07GF393J	MIL-R-11
R2	Res, Fxd, Comp; 24K, ± 5%, 1/4 W	1	RC07GF243J	MIL-R-11
R3	Res, Fxd, Comp; 2.7K, ± 5%, 1/4 W	1	RC07GF272J	MIL-R-11
R5	Res, Fxd, Comp; 10K, ± 5%, 1/4 W	1	RC07GF103J	MIL-R-11
R6	Res, Fxd, Comp; 1.5K, ± 5%, 1/4 W	1	RC07GF152J	MIL-R-11
R7	Res, Fxd, Comp; 100 ohm, ± 5%, 1/4 W	1	RC07GF101J	MIL-R-11
R8	Res, Fxd, Comp; 3.9K, ± 5%, 1/4 W	1	RC07GF392J	MIL-R-11
R10	Res, Fxd, Comp; 15K, ± 5%, 1/4 W	1	RC07GF153J	MIL-R-11
A2	Bandswitch Assy.	1	340840-1	80045
C2,C6, C9,C13	Cap, Var; 1 to 10 pf, 500 VDC (Working Volt)	4	1554-03-3	80045
C3	Cap, Fxd, Mdelec; 12 pf, ± 5%, 500 VDC (Working Volt)	1	SCDM10C120J0100	84171
C4	Cap, Fxd, Mdelec; 110 pf, ± 5%, 500 VDC (Working Volt)	1	SCDM10F111J0100	84171
C7,C11, C15	Cap, Fxd, Mdelec; 10 pf, ± 5%, 500 VDC (Working Volt)	3	SCDM10C100J0100	84171

TABLE 8-4. RECEIVER 1A3 (DWG NO. 340601) AND SUBASSEMBLIES 1A3A1 THRU 1A3A8 (Cont)

Ref. Des.	Name and Description	No. Per Unit	Part Number	Mfr.
1A3A2 ANTENNA MATCHING NETWORK (DWG. NO. 340836) (Cont)				
C8,C12	Cap, Fxd, Mdelec; 200 pf, ± 5%, 500 VDC (Working Volt)	2	SCDM10F201J0100	84171
C16	Cap, Fxd, Mdelec; 390 pf, ± 5%, 500 VDC (Working Volt)	1	SCDM10F391J0100	84171
T1	Transformer, RF; 18.3 to 1 Turns Ratio, Primary Inductance 1.29 uh to 1.69 uh @ 20 MHz, Q = 85 Min.	1	340441-1	80045
T2	Transformer, RF; 21.4 to 1 Turns Ratio, Primary Inductance 5.1 uh to 6.7 uh @ 10 MHz, Q = 80 Min.	1	340441-2	80045
T3	Transformer, RF; 24.4 to 1 Turns Ratio, Primary Inductance, 17.1 uh to 22.1 uh @ 5 MHz, Q = 70 Min.	1	340441-3	80045
T4	Transformer, RF; 21.6 to 1 Turns Ratio, Primary Inductance, 58.0 uh to 66.0 uh @ 2.5 MHz, Q = 70 Min.	1	340441-4	80045
1A3A3 RF AMPLIFIER (DWG. NO. 340835)				
A1	RF Amp. Ckt. Brd.	1	340735-1	80045
C1	Cap, Fxd, Cdelec; 0.05 uf, ±20%, 12 VDC (Working Volt)	1	5635-000Y5F0503M	72982
C2,C3	Cap, Fxd, Cdelec; 0.05 uf, Plus 80 to Minus 20%, 25 VDC (Working Volt)	2	5855-000Y5U0503Z	72982
C4	Cap, Fxd, Cdelec; 0.02 uf, Minus 20 to Plus 80%, 25 VDC (Working Volt)	1	5835-000Y5U0203Z	72982
CR1	Diode	1	1N270	
L1	Coil, RF; 1000 uh, 790 kHz	1	SWD1000	72259
Q1	Transistor	1	340197	80045
R1	Res, Fxd, Comp; 100 ohm, ± 5%, 1/4 W	1	RC07GF101J	MIL-R-11

TABLE 8-4. RECEIVER 1A3 (DWG NO. 340601) AND SUBASSEMBLIES 1A3A1 THRU 1A3A8 (Cont)

Ref. Des.	Name and Description	No. Per Unit	Part Number	Mfr.
1A3A3 RF AMPLIFIER (DWG. NO. 340835) (Cont)				
R2	Res, Fxd, Comp; 6.8K, ± 5%, 1/4 W	1	RC07GF682J	MIL-R-11
R3	Res, Fxd, Comp; 1.8K, ± 5%, 1/4 W	1	RC07GF182J	MIL-R-11
R4	Res, Fxd, Comp. 470 ohm, ± 5%, 1/4 W	1	RC07GF471J	MIL-R-11
R5	Res, Fxd, Comp; 220 ohm, ± 5%, 1/4 W	1	RC07GF221J	MIL-R-11
A2	Bandswitch Assembly	1	340840-2	80045
C2,C6, C10,C14	Cap, Fxd, Cdelec; 0.05 uf, ± 20%, 12 VDC (Working Volt)	4	1554-03-3	80045
C3,C11, C15	Cap, Fxd, Mdelec; 10 pf, ± 5%, 500 VDC (Working Volt)	3	SCDM10C100J0100	84171
C4	Cap, Fxd, Mdelec; 250 pf, ± 5%, 500 VDC (Working Volt)	1	SCDM10F251J0100	84171
C7	Cap, Fxd, Cdelec; 8 pf, ± 0.25 pf, 500 VDC (Working Volt)	1	CC20CH080C	MIL-C-20
C8	Cap, Fxd, Mdelec; 160 pf, ± 5%, 500 VDC (Working Volt)	1	SCDM10F161J0100	84171
C12	Cap, Fxd, Mdelec, 240 pf, ± 5%, 500 VDC (Working Volt)	1	SCDM10F241J0100	84171
C16	Cap, Fxd, Mdelec; 390 pf, ± 5%, 500 VDC (Working Volt)	1	SCDM10F391J0100	84171
T1	Transformer, RF; 1.34 to 1 Turns Ratio, 1.31 uh to 1.81 uh @ 20 MHz, Q = 90 Min.	1	340448-1	80045
T2	Transformer, RF; 1.55 to 1 Turns Ratio, 4.7 uh to 6.7 uh @ 10 MHz, Q = 80 Min.	1	340448-2	80045
T3	Transformer, RF; 4.17 to 1 Turns Ratio, 15.85 uh to 19.85 uh @ 5 MHz, Q = 70 Min.	1	340448-3	80045

TABLE 8-4. RECEIVER 1A3 (DWG NO. 340601) AND SUBASSEMBLIES 1A3A1 THRU 1A3A8 (Cont)

Ref. Des.	Name and Description	No. Per Unit	Part Number	Mfr.
1A3A3 RF AMPLIFIER (DWG. NO. 340835) (Cont)				
T4	Transformer, RF; 2.50 to 1 Turns Ratio, 59.0 uh to 67.0 uh @ 2.5 MHz, Q = 70 Min.	1	340448-4	80045
1A3A4 LOCAL OSCILLATOR (DWG. NO. 340834)				
A1	Local Osc. Ckt. Brd.	1	340734-1	80045
C1,C2	Cap, Fxd, Cdelec; 1000 pf, $\pm 20\%$, 500 VDC (Working Volt)	2	CK05CW102M	MIL-C-11015
C3	Cap, Fxd, Mdelec; 180 pf, $\pm 5\%$, 500 VDC (Working Volt)	1	SCDM10F181J0100	84171
C4	Cap, Fxd, Cdelec; 0.05 uf, Minus 20 to Plus 80%, 25 VDC (Working Volt)	1	5855-000Y5U0503Z	72982
CR1	Diode	1	1N459	
CR2	Diode	1	1N270	
CR3	Diode, Zener	1	1N755A	
L1	Coil, RF; 1000 uh, 790 kHz	1	SWD1000	72259
Q1,Q2	Transistor	2	2N706	
R1	Res, Fxd, Comp; 2.7K, $\pm 5\%$, 1/4 W	1	RC07GF272J	MIL-R-11
R2	Res, Fxd, Comp; 13K, $\pm 5\%$, 1/4 W	1	RC07GF133J	MIL-R-11
R3	Res, Fxd, Comp; 22K, $\pm 5\%$, 1/4 W	1	RC07GF223J	MIL-R-11
R4	Res, Fxd, Comp; 10K, $\pm 5\%$, 1/4 W	1	RC07GF103J	MIL-R-11
R5	Res, Fxd, Comp; 330 ohm, $\pm 5\%$, 1/4 W	1	RC07GF331J	MIL-R-11
R6	Res, Fxd, Comp; 4.7K, $\pm 5\%$, 1/4 W	1	RC07GF472J	MIL-R-11
R7	Res, Fxd, Comp; 1.5K, $\pm 5\%$, 1/4 W	1	RC07GF152J	MIL-R-11
A2	Bandswitch Assembly	1	340840-3	80045

TABLE 8-4. RECEIVER 1A3 (DWG NO. 340601) AND SUBASSEMBLIES 1A3A1 THRU 1A3A8 (Cont)

Ref. Des.	Name and Description	No. Per Unit	Part Number	Mfr.
1A3A4 LOCAL OSCILLATOR (DWG. NO. 340834) (Cont)				
C1,C4, C8,C12	Cap, Var; 1 to 10 pf, 500 VDC (Working Volt)	4	1554-03-3	80045
C2	Cap, Fxd, Cdelec; 4.7 pf, ± 5%, 500 VDC (Working Volt)	1	831-300R3A0-479J	72982
C5,C13	Cap, Fxd, Cdelec; 3.9 pf, ± 5%, 500 VDC (Working Volt)	2	831-300R3A0-399J	72982
C7	Cap, Fxd, Cdelec; 3600 pf, ± 5%, 200 VDC (Working Volt)	1	4C3625BH3	56289
C9	Cap, Fxd, Cdelec; 3.9 pf, ± 5%, 500 VDC (Working Volt)	1	831-300U2J0-399J	72982
C11	Cap, Fxd, Mdelec; 1300 pf, ± 5%, 100 VDC (Working Volt)	1	CD7FA132J03	14655
C15	Cap, Fxd, Mdelec; 510 pf, ± 5%, 500 VDC (Working Volt)	1	SCDM15F511J0100	84171
T1	Transformer: 1.16 uh to 1.56 uh @ 24 MHz, Q = 85	1	340497-1	80045
T2	Transformer: 4.2 uh to 5.8 uh @ 12 MHz Q = 80	1	340497-2	80045
T3	Transformer: 14.5 uh to 17.5 uh @ 6 MHz, Q = 55	1	340497-3	80045
T4	Transformer: 49.3 uh to 57.3 uh @ 3 MHz, Q = 70	1	340497-4	80045
1A3A5 PARENT BOARD ASSEMBLY (DWG. NO. 340837)				
C1	Cap, Fxd, Cdelec; 1000 pf ± 20%, 200 VDC	1	CK05CW102M	MIL-C-11015
C2,C3, C4,C5	Cap, Fxd, Cdelec; 0.2 mf ± 20%, 25 VDC	4	5815-000-Y5U-204Z	72982
R1	Res, Fxd, Comp; 330 ohm ± 5%, 1/4W	1	RC07GF331J	MIL-R-11
R2,R3	Res, Fxd, Comp; 100 ohm ± 5%, 1/4W	2	RC07GF101J	MIL-R-11

TABLE 8-4. RECEIVER 1A3 (DWG NO. 340601) AND SUBASSEMBLIES 1A3A1 THRU 1A3A8 (Cont)

Ref. Des.	Name and Description	No. Per Unit	Part Number	Mfr.
1A3A6 BFO AND CALIBRATOR ASSEMBLY (DWG. NO. 340847)				
P1	Conn, Plug, Elec; 14 Contacts, Female Type Contacts	1	MM1422PGDFSK50	95238
A1	Calibrator Board	1	340945	80045
C1	Cap, Fxd, Elec; 0.33 uf, ± 20%, 35 VDC (Working Volt)	1	CS13BF334M	MIL-C-26655
C2	Cap, Fxd, Mdelec; 180 pf, ± 5%, 500 VDC (Working Volt)	1	SCDM10F181J0100	84171
C3	Cap, Fxd, Mdelec; 560 pf, ± 5%, 500 VDC (Working Volt)	1	SCDM15F561J0100	84171
C4	Cap, Fxd, Mdelec; 12 pf, ± 5%, 500 VDC (Working Volt)	1	SCDM10C120J0100	84171
C5	Cap, Fxd, Cdelec; 10 pf, ± 5%, 500 VDC (Working Volt)	1	SCDM10C100J0100	84171
C6	Cap, Fxd, Cdelec; 33 pf, ± 10%, 500 VDC (Working Volt)	1	831-000U2M0330K	72982
C7	Cap, Fxd, Mdelec; 360 pf, ± 5%, 500 VDC (Working Volt)	1	SCDM10F361J0100	84171
C8	Cap, Fxd, Cdelec; ± 5%, 500 VDC (Working Volt) Select one of following:			
	10 pf	1	SCDM10C100J0100	84171
	12 pf	1	SCDM10C120J0100	84171
	15 pf	1	SCDM10C150J0100	84171
CR1,CR2, CR3 CR4	Diode	3	1N914	
	Diode	1	1N270	
L1	Coil, RF; 680 uh, 500 kHz ± 3%	1	340622	80045
Q1,Q2	Transistor	2	2N706	
R1,R2	Res, Fxd, Comp; 22K, ± 5%, 1/4 W	2	RC07GF223J	MIL-R-11
R3,R4	Res, Fxd, Comp; 1K, ± 5%, 1/4 W	2	RC07GF102J	MIL-R-11

TABLE 8-4. RECEIVER 1A3 (DWG NO. 340601) AND SUBASSEMBLIES 1A3A1 THRU 1A3A8 (Cont)

Ref. Des.	Name and Description	No. Per Unit	Part Number	Mfr.
1A3A6 BFO AND CALIBRATOR ASSEMBLY (DWG. NO. 340847) (Cont)				
R5	Res, Fxd, Comp; 10K, ± 5%, 1/4 W	1	RC07GF103J	MIL-R-11
R6	Res, Fxd, Comp; 680 ohm, ± 5%, 1/4 W	1	RC07GF681J	MIL-R-11
R7	Res, Fxd, Comp; 47 ohm, ± 5%, 1/4 W	1	RC07GF470J	MIL-R-11
R8	Res, Fxd, Comp; 4.7K, ± 5%, 1/4 W	1	RC07GF472J	MIL-R-11
Y1	Crystal 500 kHz	1	340670	80045
A2	BFO Board	1	340946	80045
C1	Cap, Fxd, Cdelec; 0.02 uf, Minus 20 to Plus 80% 25 VDC (Working Volt)	1	5835-000Y5U0203Z	72982
C2	Cap, Fxd, Elec; 10 uf, ± 20%, 20 VDC (Working Volt)	1	CS13BE106M	MIL-C-26655
C3	Cap, Fxd, Cdelec; 0.22 uf, 3 VDC (Working Volt)	1	UK224	71590
C4	Cap, Fxd, Cdelec; 68 pf, ± 5%, 1000 VDC (Working Volt)	1	10TCUQ68	84171
C5	Cap, Fxd, Mdelec; 300 pf, ± 5%, 500 VDC (Working Volt)	1	SCDM10F301J0100	84171
C6	Cap, Fxd, Mdelec; 4700 pf, ± 5%, 500 VDC (Working Volt)	1	SCDM19F472J0100	84171
C7	Cap, Fxd, Mdelec; 1000 pf, ± 5%, 500 VDC (Working Volt)	1	SCDM15F102J0100	84171
C8	Cap, Fxd, Cdelec; 0.05 uf, ± 20%, 12 VDC (Working Volt)	1	5635-000Y5F0503M	72982
CR1	Diode, Zener	1	1N755A	
CR2,CR3	Diode, Varactor	2	4816-03-05	80045
CR4	Diode	1	1N459	
L1	Transformer, RF; Range- 360 to 540 uh ± 10%, 455 kHz	1	340496	80045
Q1,Q2	Transistor	2	2N706	

TABLE 8-4. RECEIVER 1A3 (DWG NO. 340601) AND SUBASSEMBLIES 1A3A1 THRU 1A3A8 (Cont)

Ref. Des.	Name and Description	No. Per Unit	Part Number	Mfr.
1A3A6 BFO AND CALIBRATOR ASSEMBLY (DWG. NO. 340847) (Cont)				
R1,R2	Res, Fxd, Comp; 100K, ± 5%, 1/4 W	2	RC07GF104J	MIL-R-11
R3,R4	Res, Fxd, Comp. 18K, ± 5%, 1/4 W	2	RC07GF183J	MIL-R-11
R5	Res, Fxd, Comp; 100 ohm, ± 5%, 1/4 W	1	RC07GF101J	MIL-R-11
R6	Res, Fxd, Comp; 6.8K, ± 5%, 1/4 W	1	RC07GF682J	MIL-R-11
R7	Res, Fxd, Comp; 4.7K, ± 5%, 1/4 W	1	RC07GF472J	MIL-R-11
R8	Res, Fxd, Comp; 1.5K, ± 5%, 1/4 W	11	RC07GF152J	MIL-R-11
1A3A7 MIXER IF ASSEMBLY (DWG. NO. 340845)				
C1,C2, C4	Cap, Fxd, Cdelec; 0.05 uf, ± 20%, 12 VDC (Working Volt)	3	5635-000Y5F0503M	72982
C3,C5, C11,C17	Cap, Fxd, Elec; 0.33 uf, ± 20%, 35 VDC (Working Volt)	4	CS13BF334M	MIL-C-26655
C6	Cap, Fxd, Cdelec; 0.02 uf, Minus 20 to Plus 80%, 25 VDC (Working Volt)	1	5835-000Y5U0203Z	72982
C7,C8, C12,C13, C16,C18, C19	Cap, Fxd, Elec; 2.2 uf, ± 20%, 20 VDC (Working Volt)	7	CS13BE225M	MIL-C-26655
C9,C14	Cap, Fxd, Mdelec; 750 pf, ± 5%, 500 VDC (Working Volt)	2	CM06FD751J03	MIL-C-5C
C10,C15	Cap, Fxd, Mdelec; 430 pf, ± 5%, 500 VDC (Working Volt)	2	CM06FD431J03	MIL-C-5C
C20	Cap, Fxd, Mdelec; 220 pf, ± 5%, 500 VDC (Working Volt)	1	CM06FD221J03	MIL-C-5C
C21	Cap, Fxd, Mdelec; 33 pf, ± 10%, 500 VDC (Working Volt)		831-000U2M0330K	72982
C22	Cap, Fxd, Elec; 10 uf, ± 10%, 20 VDC (Working Volt)	1	CS13BE106K	MIL-C-26655
CR1	Diode, Zener	1	1N748A	

TABLE 8-4. RECEIVER 1A3 (DWG NO. 340601) AND SUBASSEMBLIES 1A3A1 THRU 1A3A8 (Cont)

Ref. Des.	Name and Description	No. Per Unit	Part Number	Mfr.
1A3A7 MIXER IF ASSEMBLY (DWG. NO. 340845) (Cont)				
FL1	Filter, Band Pass; 455 kHz, ± 5%	1	TL6D11A	06961
L1,L2, L3	Coil, RF; 470 uh, 790 kHz	3	WEEVL470	72259
P1	Conn, Plug, Elec; 14 Contacts, Male Type Contacts	1	MM14-22PGDFSK50	81 312
P2	Conn, Rcpt, Elec; 1 Contact, Female Type Contacts (Coax)	1	UG-1460/U	
Q1,Q8	Transistor	2	340197	80045
Q2,Q3, Q4	Transistor	3	2N706	
Q5,Q7	Transistor	2	2N956	
Q6	Transistor	1	2N2222	
R1,R8	Res, Fxd, Comp; 39K, ± 5%, 1/4 W	2	RC07GF393J	MIL-R-11
R3,R23, R19,R27	Res, Fxd, Comp; 3.9K, ± 5%, 1/4 W	4	RC07GF392J	MIL-R-11
R4,R35	Res, Fxd, Comp; 470 ohm, ± 5%, 1/4 W	2	RC07GF471J	MIL-R-11
R5,R13	Res, Fxd, Comp; 3.3K, ± 5%, 1/4 W	2	RC07GF332J	MIL-R-11
R20,R28, R33	Res, Fxd, Comp; 1.5K, ± 5%, 1/4 W	3	RC07GF152J	MIL-R-11
R7	Res, Fxd, Comp; 62K, ± 5%, 1/4 W	1	RC07GF623J	MIL-R-11
R6	Res, Fxd, Comp; 680 ohm ± 5%, 1/4 W	1	RC07GF681J	MIL-R-11
R9,R11	Res, Fxd, Comp; 2.7K, ± 5%, 1/4 W	2	RC07GF272J	MIL-R-11
R10	Res, Fxd, Comp; 22 ohm, ± 5%, 1/4 W	1	RC07GF220J	MIL-R-11
R12,R21	Res, Fxd, Comp; 220 ohm, ± 5%, 1/4 W	2	RC07GF221J	MIL-R-11
R14	Res, Fxd, Comp; 68K, ± 5%, 1/4 W	1	RC07GF683J	MIL-R-11
R15,R2	Res, Fxd, Comp; 22K, ± 5%, 1/4 W	2	RC07GF223J	MIL-R-11
R16	Res, Fxd, Comp; 4.7K, ± 5%, 1/4 W	1	RC07GF472J	MIL-R-11
R22	Res, Fxd, Comp; 82K, ± 5%, 1/4 W	1	RC07GF823J	MIL-R-11
R24	Res, Fxd, Comp; 6.8K, ± 5%, 1/4 W	1	RC07GF682J	MIL-R-11

TABLE 8-4. RECEIVER 1A3 (DWG NO. 340601) AND SUBASSEMBLIES 1A3A1 THRU 1A3A8 (Cont)

Ref. Des.	Name and Description	No. Per Unit	Part Number	Mfr.
1A3A7 MIXER IF ASSEMBLY (DWG. NO. 340845) (Cont)				
R25	Res, Fxd, Comp; 270 ohm, ± 5%, 1/4 W	1	RC07GF271J	MIL-R-11
R26,R34	Res, Fxd, Comp; 150 ohm, ± 5%, 1/4 W	2	RC07GF151J	MIL-R-11
R29	Res, Fxd, Comp; 51K,- ± 5%, 1/4 W	1	RC07GF513J	MIL-R-11
R17	Res, Fxd, Comp; 10K, ± 5%, 1/4 W	1	RC07GF103J	MIL-R-11
R32	Res, Fxd, Comp; 240 ohm, ± 5%, 1/4 W	1	RC07GF241J	MIL-R-11
R30	Res, Fxd, Comp; 5.1K ± 5%, 1/4 W	1	RC07GF512J	MIL-R-11
R31	Res, Fxd, Comp; 2K ± 5%, 1/4 W	1	RC07GF202J	MIL-R-11
1A3A8 AUDIO AMPLIFIER (DWG. NO. 340846)				
A1	Audio Board Assembly	1	340948	80045
C1	Cap, Fxd, Cdelec; 0.0047 uf, ± 5%, 100 VDC (Working Volt)	1	WM12BX472M	96733
C2	Cap, Fxd, Cdelec; 330 pf, ± 20%, 200 VDC (Working Volt)	1	CK05CW331M	MIL-C-11015
C4	Cap, Fxd, Cdelec; 6.8 pf, ± 10%, 100 VDC (Working Volt)	1	1502-03-13	80045
C5,C10, C15	Cap, Fxd, Elec; 10 uf, ± 20%, 20 VDC (Working Volt)	3	CS13BE106M	MIL-C-11015
C6	Cap, Fxd, Cdelec; 100 uf, ± 20%, 100 VDC (Working Volt)	1	WM14BX104M	96733
C7,C8, C9	Cap, Fxd, Elec; 2.2 uf, ± 20%, 20 VDC (Working Volt)	3	CS13BE225M	72982
C11,C16	Cap, Fxd, Elec; 22 uf, ± 20%, 15 VDC (Working Volt)	2	1502-03-4	80045
C12	Cap, Fxd, Cdelec; 0.02 uf, Minus 20 to Plus 80%, 25 VDC (Working Volt)	1	5835-000Y5U0203Z	72982
C13	Cap, Fxd, Elec; 33 uf, ±20%, 10 VDC (Working Volt)	1	CS13BC336M	MIL-C-26655

TABLE 8-4. RECEIVER 1A3 (DWG NO. 340601) AND SUBASSEMBLIES 1A3A1 THRU 1A3A8 (Cont)

Ref. Des.	Name and Description	No. Per Unit	Part Number	Mfr.
1A3A8 AUDIO AMPLIFIER (DWG. NO. 340846) (Cont)				
C14	Cap, Fxd, Elec; 70 uf, Plus 75 Minus 15%, 15 VDC (Working Volt)	1	1502-06-2	80045
C17	Cap, Fxd, Mdelec; 560 pf, ±5%, 500 VDC (Working Volt)	1	SCDM-15F561J0100	84171
CR1	Diode	1	1N459	
CR2	Diode	1	1N270	
P1	Conn, Plug, Elec; 26 Contacts, Male Type Contacts	1	MM26-22PGDFSK50	95238
Q1,Q2	Transistor	2	2N718A	
Q3	Transistor	1	2N956	
R1	Res, Fxd, Comp; 24K, ± 5%, 1/4 W	1	RC07GF243J	MIL-R-11
R2,R3, R13,R17	Res, Fxd, Comp; 10K, ± 5%, 1/4 W	4	RC07GF103J	MIL-R-11
R4	Resistor, Var; 10K, ± 5%, 1W	1	4752-07-03	80045
R5	Res, Fxd, Comp; 12K, ± 5%, 1/4 W	1	RC07GF123J	MIL-R-11
R6	Res, Fxd, Comp; 470K, ± 5%, 1/4 W	1	RC07GF474J	MIL-R-11
R7	Res, Fxd, Comp; 100K, ± 5%, 1/4 W	1	RC07GF104J	MIL-R-11
R8	Res, Fxd, Comp; 68K, ± 5%, 1/4 W	1	RC07GF683J	MIL-R-11
R9,R21	Res, Fxd, Comp, 330 ohm, ± 5%, 1/4 W	2	RC07GF331J	MIL-R-11
R10	Res, Fxd, Comp; 47K, ± 5%, 1/4 W	1	RC07GF473J	MIL-R-11
R11	Res, Fxd, Comp, 22K, ± 5%, 1/4 W	1	RC07GF223J	MIL-R-11
R12,R19	Res, Fxd, Comp; 1K, ± 5%, 1/4 W	2	RC07GF102J	MIL-R-11
R14	Res, Fxd, Comp; 22 ohm, ± 5%, 1/4 W	1	RC07GF220J	MIL-R-11
R15	Res, Fxd, Comp; 5.6K, ± 5%, 1/4 W	1	RC07GF562J	MIL-R-11
R16	Res, Fxd, Comp; 47 ohm, ± 5%, 1/4 W	1	RC07GF470J	MIL-R-11
R18	Res, Fxd, Comp; 3.3K, ± 5%, 1/4 W	1	RC07GF332J	MIL-R-11
R20	Res, Fxd, Comp; 12 ohm, ± 5%, 1/4 W	1	RC07GF120J	MIL-R-11

TABLE 8-4. RECEIVER 1A3 (DWG NO. 340601) AND SUBASSEMBLIES 1A3A1 THRU 1A3A8 (Cont)

Ref. Des.	Name and Description	No. Per Unit	Part Number	Mfr.
1A3A8 AUDIO AMPLIFIER (DWG. NO. 340846) (Cont)				
A2	AGC Amplifier Board	1	340949	80045
C1,C12, C13	Cap, Fxd, Cdelec; 0.02 uf, Minus 20 to Plus 80%, 25 VDC (Working Volt)	3	5835-000Y5U0203Z	72982
C2,C10	Cap, Fxd, Elec; 10 uf, ± 20%, 20 VDC (Working Volt)	2	CS13BE106M	MIL-C-26655
C5,C9	Cap, Fxd, Elec; 2.2 uf, ± 20%, 20 VDC (Working Volt)	2	CS13BE225M	MIL-C-26655
C4,C7	Cap, Fxd, Elec; 33 uf, ± 20%, 20 VDC (Working Volt)	2	CS13BC336M	MIL-C-26655
C6	Cap, Fxd, Elec; 70 uf, Minus 15 to Plus 75%, 15 VDC (Working Volt)	1	1502-06-2	80045
C8	Cap, Fxd, Cdelec; 5 pf, Minus 20 to Plus 80%, 200 VDC (Working Volt)	1	805-000X5V0502Z	72982
C11	Cap, Fxd, Cdelec; 4700 pf, ± 5%, 100 VDC (Working Volt)	1	WM12BX472M	96733
CR1,CR2, CR4	Diode	3	1N270	
CR3	Diode	1	1N459	
Q1	Transistor	1	2N2222	
Q2,Q3, Q4	Transistor	3	2N706	
Q5,Q6, Q7	Transistor	3	2N956	
R1	Res, Fxd, Comp; 100K, ± 5%, 1/4 W	1	RC07GF104J	MIL-R-11
R2	Res, Fxd, Comp. 8.2K, ± 5%, 1/4 W	1	RC07GF822J	MIL-R-11
R4	Res, Fxd, Comp; 1K, ± 5%, 1/4 W	1	RC07GF102J	MIL-R-11
R5	Res, Fxd, Comp; 240 ohm, ± 5%, 1/4 W	1	RC07GF241	MIL-R-11
R19,R21	Res, Fxd, Comp; 100 ohm, ± 5%, 1/4 W	2	RC07GF101J	MIL-R-11
R6,R10	Res, Fxd, Comp; 33K, ± 5%, 1/4 W	2	RC07GF333J	MIL-R-11
R7,R25	Res, Fxd, Comp; 2.7K, ± 5%, 1/4 W	2	RC07GF272J	MIL-R-11

TABLE 8-4. RECEIVER 1A3 (DWG NO. 340601) AND SUBASSEMBLIES 1A3A1 THRU 1A3A8 (Cont)

Ref. Des.	Name and Description	No. Per Unit	Part Number	Mfr.
1A3A8 AUDIO AMPLIFIER (DWG. NO. 340846) (Cont)				
R8,R20	Res, Fxd, Comp; 2.2K, ± 5%, 1/4 W	2	RC07GF222J	MIL-R-11
R9	Res, Fxd, Comp; 470K, ± 5%, 1/4 W	1	RC07GF474J	MIL-R-11
R11	Res, Fxd, Comp; 68K, ± 5%, 1/4 W	1	RC07GF683J	MIL-R-11
R12	Res, Fxd, Comp; 10K, ± 5%, 1/4 W	1	RC07GF103J	MIL-R-11
R13,R29	Res, Fxd, Comp; 220 ohm, ± 5%, 1/4 W	2	RC07GF221J	MIL-R-11
R14	Res, Fxd, Comp; 5.6K, ± 5%, 1/4 W	1	RC07GF562J	MIL-R-11
R15,R18, R27	Res, Fxd, Comp; 22K, ± 5%, 1/4 W	3	RC07GF223J	MIL-R-11
R16	Res, Fxd, Comp; 30K, ± 5%, 1/4 W	1	RC07GF303J	MIL-R-11
R17,R23	Res, Fxd, Comp; 47K, ± 5%, 1/4 W	2	RC07GF473J	MIL-R-11
R24,R3	Res, Fxd, Comp; 15K, ± 5%, 1/4 W	2	RC07GF153J	MIL-R-11
R22	Res, Fxd, Comp; 1.2K, ± 5%, 1/4 W	1	RC07GF122J	MIL-R-11
R26	Res, Fxd, Comp; 1.8K, ± 5%, 1/4 W	1	RC07GF182J	MIL-R-11
R28	Res, Fxd, Comp; 4.7K, ± 5%, 1/4 W	1	RC07GF472J	MIL-R-11

TABLE 8-5. TRANSMITTER 1A4 (DWG. NO. 340602) AND SUBASSEMBLIES 1A4A1 THRU 1A4A8

Ref. Des.	Name And Description	No. Per Unit	Part Number	Mfr.
1A4A1	Ant. Tune Module	1	340825	80045
1A4A2	RF Sampler Assembly	1	340759	80045
1A4A3	Motor Control No. 1	1	340830	80045
1A4A4	Motor Control No. 2	1	340831	80045
1A4A5	Modulator Assembly	1	340764	80045
1A4A6	Keying Circuit Assembly	1	340757	80045
1A4A7	Low Level Module	1	340747	80045
1A4A8	Heat Sink Assembly	1	340801	80045
1A4A9	Interwiring Board	1	340780-1	80045
C1	Variable Capacitor Assembly	1	340823	80045
C14,C15, C16	Cap, Fxd, Cdlec; 0.1 uf, ± 20%, 50 VDC (Working Volt)	3	VK30BX104M	95275

TABLE 8-5. TRANSMITTER 1A4 (DWG. NO. 340602) AND SUBASSEMBLIES 1A4A1 THRU 1A4A8 (Cont)

Ref. Des.	Name and Description	No. Per Unit	Part Number	Mfr.
CR3,CR4	Diode, Protection	2	4813-04	80045
J5,J6	Conn, Rcpt, Elec; 1 Contact Male Type Contacts	2	27-9	74868
L1	Inductor Assembly	1	340824	80045
P1	Conn, Plug, Elec; 20 Contacts, Male Type Contacts	1	MM20-22PDGFSK50	95238
P2	Jack, Banana, Antenna	1	205-102	83330
P3	Jack, Banana, Antenna	1	205-103	83330
R15	Res, Fxd, Comp; 470 ohm, ± 5%, 1W	1	RC32GF471J	MIL-R-11
S3	Switch, Rotary; 2 Deck, 4 Pole, 2 Throw, Nonshorting Contacts	1	340976	80045
1A4A1 ANTENNA TUNING MODULE (DWG. NO. 340825)				
C1,C2, C3	Cap, Fxd, Cdelec; 560 pf, ± 10%, 200 VDC (Working Volt)	3	CK05CW561K	MIL-C-11015
C4	Cap, Fxd, Cdelec; 22 pf, ± 20%, 200 VDC (Working Volt)	1	CK05CW220M	MIL-C-11015
C5	Cap, Fxd, Elec; 1 uf, ± 20%, 20 VDC (Working Volt)	1	1502-01-17	80045
C6	Cap, Fxd, Elec; 15 uf, ± 20%, 15 VDC (Working Volt)	1	1502-03-3	80045
C7	Cap, Fxd, Cdelec; 0.01 uf ± 10%, 100 VDC (Working Volt)	1	CK05BX103K	MIL-C-11015
CR1,CR2, CR3,CR4	Diode	4	1N916	
L1	Coil, RF; 0.53 uh ±5% @ 25 MHz Q = 80 Min.	1	340189	
R1	Res, Fxd, Comp; 100 ohm, ± 5%, 1/4 W	1	RC07GF101J	MIL-R-11
R2	Res, Fxd, Comp; 10K, ± 5%, 1/4 W	1	RC07GF103J	MIL-R-11

TABLE 8-5. TRANSMITTER 1A4 (DWG. NO. 340602) AND SUBASSEMBLIES 1A4A1 THRU 1A4A8 (Cont)

Ref. Des.	Name and Description	No. Per Unit	Part Number	Mfr.
1A4A1 ANTENNA TUNING MODULE (DWG. NO. 340825) (Cont)				
R3	Res, Fxd, Comp; 680 ohm, ± 5%, 1/4 W	1	RC07GF681J	MIL-R-11
R4	Res, Fxd, Comp; 820 ohm, ± 5%, 1/4 W	1	RC07GF821J	MIL-R-11
R5,R6, R7,R8	Res, Fxd, Comp; 82K, ± 5%, 1/4 W	4	RC07GF823J	MIL-R-11
R9	Res, Fxd, Comp; 560 ohm, ± 5%, 1/4 W	1	RC07GF561J	MIL-R-11
R10	Res, Fxd, Comp; 13K, ± 5%, 1/4 W	1	RC07GF133J	MIL-R-11
R11	Res, Fxd, Comp; 240 ohm, ± 5%, 1/4 W	1	RC07GF241J	MIL-R-11
R12	Res, Var, Comp; 5K	1	80-3-4-502	02111
T1	Transformer, RF; 25 MHz Operating Freq.	1	340827	80045
1A4A2 RF SAMPLER (DWG. NO. 340759)				
C1	Cap, Fxd, Elec; 0.1 uf, ± 10%, 20 VDC (Working Volt)	1	1502-01-4	80045
C3,C7	Cap, Var; 9-35 pf, ± 5%, 25 VDC (Working Volt)	2	538-006-940	72982
C4,C6	Cap, Fxd, Cdelec; 20 pf, ± 10%, 100 VDC (Working Volt)	2	1501-19-88	80045
C5	Cap, Fxd, Elec; 180 pf, ± 5%, 100 VDC (Working Volt)	1	VL02BX181J	95275
C8	Cap, Fxd, Cdelec; 270 pf, ±10%, 100 VDC (Working Volt)	1	1501-19-36	80045
C9,C10	Cap, Fxd, Elec; 0.01 uf, ± 20%, 20 VDC (Working Volt)	2	1502-01-32	80045
C11	Cap, Fxd, Cdelec; ± 5%, 100 VDC (Working Volt) Select one of following:			
	10 pf	1	1501-19-1	80045
	12 pf	1	SCDM10C120J0100	84171
	15 pf	1	SCDM10C150J0100	84171
C12	Cap, Fxd, Cdelec; 18 pf, ± 5%, 100 VDC (Working Volt)	1	1501-19-5	80045

TABLE 8-5. TRANSMITTER 1A4 (DWG. NO. 340602) AND SUBASSEMBLIES 1A4A1
THRU 1A4A8 (Cont)

Ref. Des.	Name and Description	No. Per Unit	Part Number	Mfr.
1A4A2 RF SAMPLER (DWG NO. 340759) (Cont)				
C13,C2	Cap, Fxd, Cdelec; 39 pf, ± 5%, 100 VDC (Working Volt)	2	1501-19-13	80045
CR1,CR2	Diode - ALC Detector	2	1N916	MIL-S-19500
K1	Relay, Armature; DPDT, 12 VDC Coil	1	90120201	61775
L1,L4	Coil, RF; 100 uh, ± 10% 2.5 MHz, Q = 50 Min.	2	1802-01-9	80045
L2,L3	Coil, RF; 1 mh, ± 10%, 790 kHz, Q = 28 Min.	2	1802-01-14	80045
L5,L6, L7	Coil, RF; 1.5 uh, ± 5%, 7.9 MHz, Q = 28 Min.	3	1802-01-19	80045
R1	Res, Fxd, Comp; 4.7K, ± 5%, 1/4 W	1	RC07GF472J	MIL-R-11
R2,R3, R4,R5	Res, Fxd, Comp; 150 ohm, ± 5%, 1/4 W	4	RC07GF151J	MIL-R-11
R6	Res, Fxd, Comp; 100 ohm, ± 5%, 1/4 W	1	RC07GF101J	MIL-R-11
R7,R18	Res, Fxd, Comp; 390 ohm, ± 5%, 1/2 W	12	RC20GF391J	MIL-R-11
R19	Res, Var, Comp; 20K, ± 5%, 1 W	1	215-72-HS-20K	94271
T1,T2	Coil, RF; 24 MHz Operating Freq.	2	340766	80045
1A4A3 MOTOR CONTROL BOARD NO. 1 (DWG. NO. 340830)				
C1,C2, C3,C5	Cap, Fxd, Elec; 22 uf, ± 20%, 15 VDC (Working Volt)	4	1502-03-4	80045
C4	Cap, Fxd, Elec; 1 uf, ± 20%, 20 VDC (Working Volt)	1	1502-01-17	80045
C6	Cap, Fxd, Elec; 15 uf, ± 20%, 15 VDC (Working Volt)	1	1502-03-3	80045
C7	Cap, Fxd, Elec; 47 uf, ± 20%, 6 VDC (Working Volt)	1	1502-03-20	80045
C8	Cap, Fxd, Elec; 0.01 uf, ± 5%, 20 VDC (Working Volt)	1	1502-01-24	80045

TABLE 8-5. TRANSMITTER 1A4 (DWG. NO. 340602) AND SUBASSEMBLIES 1A4A1
THRU 1A4A8 (Cont)

Ref. Des.	Name and Description	No. Per Unit	Part Number	Mfr.
1A4A3 MOTOR CONTROL BOARD NO. 1 (DWG. NO. 340830) (Cont)				
C9	Cap, Fxd, Cdelec; 560 pf ± 10%, 100 VDC (Working Volt)	1	1501-19-44	80045
CR1	Diode, Zener	1	1N748A	
CR2	Diode, Zener	1	1N960B	
CR3,CR4, CR5,CR6 CR7	Diode	4	4813-04	80045
	Diode, Zener	1	1N746A	
L1	Coil, RF; 470 uh, ± 10%, 790 kHz, Q = 27 Min.	1	1802-01-13	80045
L2	Coil, RF; 1.2 mh, ± 10%, 250 kHz, Q = 70 Min.	1	1801-01-1	80045
Q1	Transistor	1	2N3250	
Q2	Transistor	1	4824-03-1	80045
Q3	Transistor	1	2N718A	
R1	Res, Fxd, Comp; 270 ohm, ±5%, 1/4 W	1	RC07GF271J	MIL-R-11
R2	Res, Fxd, Comp; 220 ohm, ±5%, 1/4 W	1	RC07GF221J	MIL-R-11
R3	Res, Fxd, Comp; 3.3K, ±5%, 1/4 W	1	RC07GF332J	MIL-R-11
R4	Res, Fxd, Comp; 9.1K, ±5%, 1/4 W	1	RC07GF912J	MIL-R-11
R5	Res, Fxd, Comp; 1K, ±5%, 1/4 W	1	RC07GF102J	MIL-R-11
R6	Res, Fxd, Comp; 180K, ±5%, 1/4 W	1	RC07GF184J	MIL-R-11
R7	Res, Fxd, Comp; 6.8K, ±5%, 1/4 W	1	RC07GF682J	MIL-R-11
R8	Res, Fxd, Comp; 10 ohm, ±5%, 1/4 W	1	RC07GF100J	MIL-R-11
R9	Res, Fxd, Comp; 2.7K, ±5%, 1/4 W	1	RC07GF272J	MIL-R-11
R11	Res, Fxd, Comp. 820 ohm, ±5%, 1/4 W	1	RC07GF821J	MIL-R-11
R12	Res, Fxd, Comp; 18K, ±5%, 1/4 W	1	RC07GF183J	MIL-R-11
R13	Res, Fxd, Comp; 150 ohm, ±5%, 1/4 W	1	RC07GF151J	MIL-R-11
R14	Res, Fxd, Comp; 1.2K, ±5%, 1/4 W	1	RC07GF122J	MIL-R-11

TABLE 8-5. TRANSMITTER 1A4 (DWG. NO. 340602) AND SUBASSEMBLIES 1A4A1 THRU 1A4A8 (Cont)

Ref. Des.	Name and Description	No. Per Unit	Part Number	Mfr.
1A4A3 MOTOR CONTROL BOARD NO. 1 (DWG. NO. 340830) (Cont)				
R15	Res, Fxd, Comp; 47K, ±5%, 1/4 W	1	RC07GF473J	MIL-R-11
Z1	Integrated Circuit	1	4851-31	80045
1A4A4 MOTOR CONTROL BOARD NO. 2 (DWG. NO. 340831)				
C1,C5	Cap, Fxd, Elec; 1.8 uf, ±10%, 15 VDC (Working Volt)	2	1502-01-11	80045
C2	Cap, Fxd, Elec; 2.2 uf, ±20%, 20 VDC (Working Volt)	1	1502-01-18	80045
C3	Cap, Fxd, Elec; 1.8 uf, ±20%, 15 VDC (Working Volt)	1	1502-01-33	80045
C4	Cap, Fxd, Elec; 0.33 uf, ±20%, 20 VDC (Working Volt)	2	1502-01-16	80045
CR1,CR2, CR3,CR4, CR5	Diode	5	4813-04	80045
CR6	Diode	1	1N270	
Q1,Q7	Transistor	2	2N3250	
Q2,Q3, Q6	Transistor	3	2N718A	
Q4,Q5	Transistor	2	2N956	
R1	Res, Fxd, Comp; 2.2K, ±5%, 1/4 W	1	RC07GF222J	MIL-R-11
R2,R3	Res, Fxd, Comp, 680 ohm, ±5%, 1/4 W	2	RC07GF681J	MIL-R-11
R4,R7 R10,R11	Res, Fxd, Comp; 6.8K, ±5%, 1/4 W	4	RC07GF682J	MIL-R-11
R5	Res, Fxd, Comp; 12K, ±5%, 1/4 W	1	RC07GF123J	MIL-R-11
R6	Res. Fxd, Comp; 5.6K, ±5%, 1/4 W	1	RC07GF562J	MIL-R-11
R8,R12	Res, Fxd, Comp; 560 ohm, ±5%, 1/4 W	2	RC07GF561J	MIL-R-11
R9,R13, R16	Res, Fxd, Comp; 47K, ±5%, 1/4 W	3	RC07GF473J	MIL-R-11
R14	Res, Fxd, Comp. 27K, ±5%, 1/4 W	1	RC07GF273J	MIL-R-11
R15,R17	Res, Fxd, Comp; 10K, ±5%, 1/4 W	2	RC07GF103J	MIL-R-11

TABLE 8-5. TRANSMITTER 1A4 (DWG. NO. 340602) AND SUBASSEMBLIES 1A4A1 THRU 1A4A8 (Cont)

Ref. Des.	Name and Description	No. Per Unit	Part Number	Mfr.
1A4A4 MOTOR CONTROL BOARD NO. 2 (DWG. NO. 340831) (Cont)				
R18	Res, Fxd, Comp; 1.2K, ±5%, 1/4 W	1	RC07GF122J	MIL-R-11
Z1,Z2	Integrated Circuit	2	U31993051X	07263
1A4A5 MODULATOR CHASSIS ASSEMBLY (DWG. NO. 340764)				
C1	Cap, Fxd, Elec; 1 uf, ±20%, 20 VDC (Working Volt)	1	1502-01-17	80045
C2	Cap, Fxd, Elec; 2.2 uf, ±20%, 20 VDC (Working Volt)	1	1502-01-18	80045
C3	Cap, Fxd, Elec; 10 uf, ±20%, 20 VDC	1	1502-03-7	80045
C4	Cap, Fxd, Elec; 6.8 uf, ±5%, 20 VDC	1	1502-03-22	80045
C5	Cap, Fxd, Elec; 15 uf, ±20%, 15 VDC (Working Volt)	1	1502-03-3	80045
C7	Cap, Fxd, Elec; 6.8 uf, ±10%, 10 VDC (Working Volt)	1	1502-03-13	80045
C8	Cap, Fxd, Elec; 22 uf, ±20%, 15 VDC (Working Volt)	1	1502-03-4	80045
C9,C10	Cap, Fxd, Elec; 1.5 uf, Minus 20 to Plus 40%, 15 VDC (Working Volt)	2	F155R	17554
C12	Cap, Fxd, Elec; 15 uf, ±10%, 20 VDC (Working Volt)	1	1502-03-6	80045
C13,C6	Cap, Fxd, Elec; 10 uf, ±20%, 6 VDC (Working Volt)	2	1502-03-1	
CR1,CR2, CR4	Diode	3	4813-04	80045
CR3	Diode	1	1N752	
CR5	Diode	1	1N4733	
CR6	Diode	1	1N4728	
Q1,Q2, Q3,Q4, Q5,Q6	Transistor	6	2N718	
Q7	Transistor	1	2N2906	

TABLE 8-5. TRANSMITTER 1A4 (DWG. NO. 340602) AND SUBASSEMBLIES 1A4A1 THRU 1A4A8 (Cont)

Ref. Des.	Name and Description	No. Per Unit	Part Number	Mfr.
1A4A5 MODULATOR CHASSIS ASSEMBLY (DWG. NO. 340764) (Cont)				
R1	Res, Fxd, Comp; 150 ohm, ±5%, 1/4 W	1	RC07GF151J	MIL-R-11
R2	Res, Fxd, Comp; 18K, ±5%, 1/4 W	1	RC07GF183J	MIL-R-11
R3,R6, R15	Res, Fxd, Comp; 3.3K, ±5%, 1/4 W	3	RC07GF332J	MIL-R-11
R4,R18, R21	Res, Fxd, Comp; 1K, ±5%, 1/4 W	3	RC07GF102J	MIL-R-11
R5	Res, Fxd, Comp; 43K, ±5%, 1/4 W	1	RC07GF433J	MIL-R-11
R7	Res, Fxd, Comp; 6.8K, ±5%, 1/4 W	1	RC07GF682J	MIL-R-11
R8,R13	Res, Fxd, Comp; 100 ohm, ±5%, 1/4 W	2	RC07GF101J	MIL-R-11
R9	Res, Fxd, Comp; 22K, ±5%, 1/4 W	1	RC07GF223J	MIL-R-11
R10	Res, Fxd, Comp; 220 ohm, ±5%, 1/4 W	1	RC07GF221J	MIL-R-11
R11	Res, Fxd, Comp; 7.5K, ±5%, 1/4 W	1	RC07GF752J	MIL-R-11
R12	Res, Fxd, Comp; 1.6K, ±5%, 1/4 W	1	RC07GF162J	MIL-R-11
R14	Res, Fxd, Comp; 330 ohm, ±5%, 1/4 W	1	RC07GF331J	MIL-R-11
R16	Res, Fxd, Comp; 39K, ±5%, 1/4W	1	RC07GF393J	MIL-R-11
R17	Res, Fxd, Comp. 39K, ±5%, 1/4 W	1	RC07GF392J	MIL-R-11
R19	Res, Fxd, Comp; 5.6K, ±5%, 1/4 W	1	RC07GF562J	MIL-R-11
R20	Resistor, Selected Value (See par. 3.6.4)	1	RC07GF272J to RC07GF332J	MIL-R-11
R22	Res, Fxd, Comp; 1.3K, ±5%, 1/4 W	1	RC07GF132J	MIL-R-11
R23	Res, Fxd, Comp; 47 ohm, ±5%, 1/4 W	1	RC07GF470J	MIL-R-11
R24	Res, Fxd, WW; 82 ohm, ±5%, 1/2 W	1	T-1/2 A82 ohms-3	12463
R25	Res, Fxd, Comp; 240 ohm, ±5%, 1/4 W	1	RC07GF241J	MIL-R-11
R26	Res, Fxd, Comp; 430 ohm, ±5%, 1/4 W	1	RC07GF431J	MIL-R-11

TABLE 8-5. TRANSMITTER 1A4 (DWG. NO. 340602) AND SUBASSEMBLIES 1A4A1 THRU 1A4A8 (Cont)

Ref. Des.	Name and Description	No. Per Unit	Part Number	Mfr.
1A4A6 KEYING CIRCUIT (DWG. NO. 340757)				
C1	Cap, Fxd, Elec; 10 uf, ±20%, 20 VDC (Working Volt)	1	1502-03-7	80045
C2	Cap, Fxd, Elec; 0.01 uf, ±5%, 20 VDC (Working Volt)	1	1502-01-24	80045
C3	Cap, Fxd, Elec; 0.47 uf, ±20%, 20 VDC (Working Volt)	1	1502-01-17	80045
C4	Cap, Fxd, Elec; 1 uf, ±20%, 20 VDC (Working Volt)	1	4813-04	80045
CR2,CR3, CR4,CR5, CR6,CR8	Diode	6	PG20	01295
Q1	Transistor	1	2N2906	
Q2	Transistor	1	2N3250	
Q3,Q4	Transistor	2	2N718A	
Q5	Transistor UJT	1	2N2646	
R1	Res, Fxd, Comp; 1.2K, ±5%, 1/4 W	1	RC07GF122J	MIL-R-11
R2	Res, Fxd, Comp; 33K, ±5%, 1/4 W	1	RC07GF333J	MIL-R-11
R3	Res, Fxd, Comp; 390 ohm, ±5%, 1/4 W	1	RC07GF391J	MIL-R-11
R4	Res, Fxd, Comp; 3.6K, ±5%, 1/4 W	1	RC07GF362J	MIL-R-11
R5,R7	Res, Fxd, Comp; 470 ohm, ±5%, 1/4 W	2	RC07GF471J	MIL-R-11
R6	Res, Fxd, Comp; 2.7K, ±5%, 1/4 W	1	RC07GF272J	MIL-R-11
R8	Res, Fxd, Comp; 12K, ±5%, 1/4 W	1	RC07GF123J	MIL-R-11
1A4A7 LOW LEVEL MODULE (DWG. NO. 340747)				
C1,C11	Cap, Fxd, Cdelec; 0.01 uf, ±20%, 100 VDC (Working Volt)	2	1501-19-75	80045
C2,C10	Cap, Var; 8-25 pf, Minus 1 to Plus 6.5% 200 VDC (Working Volt)	2	538-011-99C	72982
C3	Cap, Fxd, Cdelec; 220 pf, ±10%, 100 VDC (Working Volt)	1	1501-19-34	80045

TABLE 8-5. TRANSMITTER 1A4 (DWG. NO. 340602) AND SUBASSEMBLIES 1A4A1
THRU 1A4A8 (Cont)

Ref. Des.	Name and Description	No. Per Unit	Part Number	Mfr.
1A4A7 LOW LEVEL MODULE (DWG. NO. 340747) (Cont)				
C4,C6, C7,C8, C12,C18, C19,C20, C21, C23 C9	Cap, Fxd, Elec; 0.01 uf, ±5%, 50 VDC (Working Volt)	10	1502-01-1	80045
C9	Cap, Fxd, Cdelec; 20 pf, ±10%, 100 VDC (Working Volt)	1	MC70A200AK	71471
C13,C27	Cap, Fxd, Cdelec, 0.1 uf, ±20%, 50 VDC (Working Volt)	2	VK30BX104M	92575
C14	Cap, Fxd, Tant; 15 uf, ±20%, 15 VDC (Working Volt)	1	1502-03-3	80045
C17,C22	Cap, Fxd, Elec; 1.8 uf, ±10%, 15 VDC (Working Volt)	2	1502-01-11	80045
C15,C16	Cap, Fxd, Cdelec; 4.7 pf, ±20%, 100 VDC (Working Volt)	2	WM12BX472M	96733
C24,C25, C31	Cap, Fxd, Cdelec; 1 uf, ±10%, 100 VDC (Working Volt)	3	1501-19-50	80045
C26	Cap, Fxd, Elec; 0.1 uf, ±10%, 20 VDC (Working Volt)	1	1502-01-4	80045
C28	Cap, Fxd, Elec; 15 uf, ±20%, 20 VDC (Working Volt)	1	1502-03-6	80045
C30	Cap, Fxd, Elec; 6.8 uf, ±20%, 20 VDC (Working Volt)	1	1502-03-13	80045
CR1	Diode	1	1N752	
CR2,CR3	Diode	2	1N645	
CR4	Diode	1	1N751	
CR5,CR6, CR7,CR8, CR29	Diode	5	4813-04	80045
CR9,CR10	Diode	2	1N270	
L1,L2	Coil, RF; Cp must be no greater than 2.8 pf from 2 to 12 MHz	2	340564	80045
L3	Coil, RF; 1.2 mh, 250 kHz, Q = 70 Min.	1	1801-01-1	80045

TABLE 8-5. TRANSMITTER 1A4 (DWG. NO. 340602) AND SUBASSEMBLIES 1A4A1 THRU 1A4A8 (Cont)

Ref. Des.	Name and Description	No. Per Unit	Part Number	Mfr.
1A4A7 LOW LEVEL MODULE (DWG. NO. 340747) (Cont)				
Q1,Q2, Q3,Q5, Q6,Q7, Q8,Q9, Q10,Q11, Q29	Transistor	11	2N2221	
Q4	Transistor	1	2N2906	
R1,R50	Res, Fxd, Comp; 4.7K, ±5%, 1/4 W	2	RC07GF472J	MIL-R-11
R2	Resistor, Selected Value (See par. 4.4.1.1b.9)	1	RC07GF302J to RC07GF472J	MIL-R-11
R3,R25, R29,R33	Res, Fxd, Comp; 1K, ±5%, 1/4 W	4	RC07GF102J	MIL-R-11
R4	Res, Fxd, Comp. 56 ohm, ±5%, 1/4 W	1	RC07GF560J	MIL-R-11
R5	Resistor, Assy; 1.5K, ±5%, 1/4 W	1	350424	80045
R6,R9	Res, Fxd, Comp; 22K, ±5%, 1/4 W	2	RC07GF223J	MIL-R-11
R8	Res, Fxd, Comp. 1.2K, ±5%, 1/4 W	1	RC07GF122J	MIL-R-11
R10	Res, Fxd, Comp; 330 ohm, ±5%, 1/4 W	1	RC07GF331J	MIL-R-11
R11,R12, R37	Res, Fxd, Comp; 5.6K, ±5%, 1/4 W	3	RC07GF562J	MIL-R-11
R13,R15	Res, Fxd, Comp; 15 ohm, ±5%, 1/4 W	2	RC07GF150J	MIL-R-11
R14	Res, Var; 0 to 50 ohm, ±20%, 1/4 W	1	MF2S-50	07479
R16,R27, R35,R40	Res, Fxd, Comp; 10 ohm, ±5%, 1/4 W	4	RC07GF100J	MIL-R-11
R17,R32	Res, Fxd, Comp; 100 ohm, ±5%, 1/4 W	2	RC07GF101J	MIL-R-11
R18	Res, Fxd, Comp; 18 ohm, ±5%, 1/4 W	1	RC07GF180J	MIL-R-11
R19	Res, Fxd, Comp; 6.2 ohm ±5%, 1/4 W	1	RC07GF6R2J	MIL-R-11
R20	Res, Fxd, Comp. 51 ohm, ±5%, 1/4 W	1	RC07GF510J	MIL-R-11
R22	Res, Fxd, Comp; 47 ohm, ±5%, 1/4 W	1	RC07GF470J	MIL-R-11
R23 (Select 1)	Res, Fxd, Comp; 1.8K, ±5%, 1/4 W	1	RC07GF182J	MIL-R-11
	Res, Fxd, Comp; 1.5K, ±5%, 1/4 W		RC07GF152J	MIL-R-11
	Res, Fxd, Comp; 1.3K, ±5%, 1/4 W		RC07GF132J	MIL-R-11

TABLE 8-5. TRANSMITTER 1A4 (DWG. NO. 340602) AND SUBASSEMBLIES 1A4A1 THRU 1A4A8 (Cont)

Ref. Des.	Name and Description	No. Per Unit	Part Number	Mfr.
1A4A7 LOW LEVEL MODULE (DWG. NO. 340747) (Cont)				
R24	Res, Fxd, Comp; 5.1K ±5%, 1/4 W	1	RC07GF512J	MIL-R-11
R26	Res, Fxd, Comp; 1.5K, ±5%, 1/4 W	1	RC07GF152J	MIL-R-11
R31	Res, Fxd, Comp; 3.3K, ±5%, 1/4 W	1	RC07GF332J	MIL-R-11
R34	Res, Fxd, Comp; 220 ohm, ±5%, 1/4 W	1	RC07GF221J	MIL-R-11
R36	Res, Fxd, Comp; 3.9K, ±5%, 1/4 W	1	RC07GF392J	MIL-R-11
R38,R39	Res, Fxd, Comp; 5.1 ohm, ±5%, 1/4 W	2	RC07GF5R1J	MIL-R-11
R41,R48, R49,R50	Res, Fxd, Comp; 82 ohm, ±5%, 1/4 W	4	RC07GF820J	MIL-R-11
R42	Res, Thermal; 10K, ±10%, 1/4 W	1	TM 1/4-10K	01295
R43	Res, Thermal; 220 ohm, ±10%, 1/8 W	1	TM 1/8-220	01295
R44 (Select 1)	Res, Fxd, Comp; 820 ohm, ±5%, 1/4 W	1	RC07GF821J	MIL-R-11
	Res, Fxd, Comp; 1K, ±5%, 1/4 W		RC07GF102J	MIL-R-11
R45 (Select 1)	Res, Fxd, Comp; 1.8K, ±5%, 1/4 W	1	RC07GF182J	MIL-R-11
	Res, Fxd, Comp; 910 ohm, ±5%, 1/4 W		RC07GF910J	MIL-R-11
R47	Res, Fxd, Comp; 100K, ±5%, 1/4 W	1	RC07GF104J	MIL-R-11
R52	Res, Thermal; 90 ohm ±10%	1	RL2B1	75263
T1	Transformer, RF; 2 to 12 MHz	1	340767	80045
T2	Transformer, RF; 2 to 12 MHz	1	340768	80045
T3	Transformer, RF; 2 to 12 MHz	1	340769	80045
Z1	Impedance Network	1	340154	80045
1A4A8 DRIVER FINAL ASSEMBLY (DWG. NO. 340801)				
C1	Cap, Fxd, Cdelec; 0.1 uf, ±20%, 50 VDC (Working Volt)	1	VK30BX104M	92575
C4	Capacitor Assy.	1	340910	80045

TABLE 8-5. TRANSMITTER 1A4 (DWG. NO. 340602) AND SUBASSEMBLIES 1A4A1 THRU 1A4A8 (Cont)

Ref. Des.	Name and Description	No. Per Unit	Part Number	Mfr.
1A4A8 DRIVER FINAL ASSEMBLY (DWG. NO. 340801) (Cont)				
C10	Cap, Fxd, Elec; 47 uf, ±20%, 15 VDC (Working Volt)	1	K47P25	05397
C11,C12	Cap, Fxd, Cdelec; 560 pf, ±10%, 100 VDC (Working Volt)	2	1501-19-44	80045
C13	Cap, Fxd, Elec; 10 uf, ±20%, 20 VDC (Working Volt)	1	CS13BE106M	MIL-C-26655
CR2	Diode	1	4813-04	80045
K1,K3, K4	Relay, Armature; DPDT, 12 VDC Coil	3	SX2333	70309
K2	Relay, Armature; DPDT, 12 VDC Coil	1	SX2332	70309
	Ckt. Assy-Feedback Mod	2	340999	80045
	Ckt. Assy-Filter Mod	1	340716	80045
L1	Coil	1	340097	80045
MTR-1	Gear Motor, Assy	1	340502	80045
Q1,Q2	Transistor	2	2N3924	
Q3,Q4	Transistor	2	340969	
Q5	Transistor	1	340065	80045
	Resistor Assy	1	340094-1	80045
	Resistor Assy	1	340094-2	80045
R3,R4	Res, Fxd, Comp; 4.7 ohm, ±5%, 1/4 W	2	RC07GF4R7J	
R5,R8	Res, Fxd, Comp; 10 ohm, ±5%, 1/4 W	2	RC07GF100J	
R10	Res, Fxd, Comp; 2.2K, ±5%, 1/2 W	1	RC20GF222J	
R13,R14	Res, Fxd, Comp; 39 ohm, ±5%, 1/2 W	2	RC20GF390J	
R15 (Select 1)	Res, Fxd, Comp; 82 ohm, ±5%, 1/4 W	1	RC07GF820J	
	Res, Fxd, Comp; 100 ohm ±5%, 1/4 W		RC07GF101J	
	Res, Fxd, Comp; 180 ohm ±5%, 1/4 W		RC07GF181J	

TABLE 8-5. TRANSMITTER 1A4 (DWG. NO. 340602) AND SUBASSEMBLIES 1A4A1 THRU 1A4A8 (Cont)

Ref. Des.	Name and Description	No. Per Unit	Part Number	Mfr.
1A4A8 DRIVER FINAL ASSEMBLY (DWG. NO. 340801) (Cont)				
S1	Switch, Thermal, N.C., SPST, Opens on Temp. Rise	1	3BT L3-38	14859
S2	Switch, Sensitive, SPDT	1	1SX1T	91929
T1	Transformer, RF; 2 to 24 MHz	1	340770	80045
T2	Transformer, RF; 2 to 24 MHz	1	340771	80045
T3	Transformer, RF; 2 to 24 MHz	1	340185	80045

