

CE-130  
June 1960

INSTRUCTIONS  
AND  
PARTS BREAKDOWN

**RADIO RECEIVER MODELS  
GPR-90RX AND GPR - 90**

Prepared by  
***Western Electric Company***  
INCORPORATED  
DEFENSE PROJECTS DIVISION  
220 Church Street, N. Y. 13, N. Y.  
for UNITED STATES AIR FORCE  
Contract No. AF 33(600)36661

**LIST OF MODIFICATIONS**

The material contained in this publication reflects no Field changes, and is current to June, 1960. In the space provided below, list equipment modifications since June, 1960.

<u>Modification No.</u>	<u>Paragraph</u>	<u>Description of Modification</u>
-------------------------	------------------	------------------------------------

## TABLE OF CONTENTS

### I. INITIAL INSTALLATION, USE, AND MAINTENANCE

<i>Section</i>	<i>Page</i>	<i>Section</i>	<i>Page</i>
1. FUNCTION, DESCRIPTION, AND INITIAL INSTALLATION		3. PREVENTIVE MAINTENANCE ROUTINES AND METHODS (Continued)	
Subject and Purpose of This Handbook	1	Maintenance Routines and Intervals.....	11
Function of Receiver Models GPR-90RX and GPR-90	1	Preventive Maintenance Procedures for Receiver Models GPR-90RX and GPR-90	11
Description of Receiver Model GPR-90RX and GPR-90	1	Performance Check	11
Identification	1	External Inspection	11
Physical Description	1	Cleaning	11
Table of Specifications	1		
Initial Installation Procedures	1	4. ADJUSTMENTS AND REPLACEMENTS	
Location	2	Subject and Purpose of This Section...	13
Antenna Selection and Installation	2	Tools, Apparatus, and Materials	13
Speaker Installation	2	Corrective Maintenance Procedures	13
Power Source	2	Trouble Analysis Methods	13
Wiring for Break-In Operation	3	Preliminary Troubleshooting Procedures	13
Accessories	3	Minimum Performance Check	14
External Oscillator	3	Trouble Table	14
		Voltage Measurements	18
2. OPERATING ROUTINES AND METHODS		Resistance Measurements	18
Subject and Purpose of This Section	7	Audio Gain Test	18
Tools, Apparatus, and Materials	7	I-F Gain Test	18
Function of Controls	7	R-F Gain Test	20
Operating Routines and Intervals	7	I-F Alignment Procedures	21
Procedures for Operating Receiver Models GPR-90RX and GPR-90	7	R-F Alignment Procedures	23
Operating Procedures for AM and MCW Reception	7	Adjustment Procedures for HUM BALANCE Control	24
Operating Procedures for CW Reception	8	Calibration of S Meter	24
Operating Procedures for SSB Reception	8		
Operating Procedures When Using External Oscillator	8	5. THEORY OF OPERATION	
Frequency of External Oscillator	9	Subject and Purpose of This Section	25
Operating Procedures When Using Crystal-Controlled, High-Frequency Oscillator	9	How Radio Receiver Models GPR-90RX and GPR-90 Work	25
Frequency of Crystals	9	Antenna Circuits and R-F Circuits	25
Operating Procedures for Checking Calibration Oscillator	10	Conversion Circuits	27
		I-F Circuits	27
		Detector, Limiter, and AVC	27
		Audio Circuits	28
		Receiver Power	28
		Circuit Analysis of Radio Receiver Models GPR-90RX and GPR-90	28
3. PREVENTIVE MAINTENANCE ROUTINES AND METHODS		Antenna Circuit	28
Subject and Purpose of This Section	11	R-F Amplifier Circuits	28
Tools, Apparatus, and Materials	11	Local Oscillator	33
		Crystal Oscillator-Amplifier	34

<i>Section</i>	<i>Page</i>	<i>Section</i>	<i>Page</i>
5. THEORY OF OPERATION (Continued)		5. THEORY OF OPERATION (Continued)	
Conversion Circuits .....	34	Detector and Noise Limiter .....	36
Buffer I-F Amplifier .....	34	AVC and First Audio Amplifier .....	37
Crystal Filter .....	34	Second Audio Amplifier .....	37
I-F Amplifiers .....	35	Calibration Oscillator .....	37
Beat Frequency Oscillator .....	36	Power Supply .....	38

**II. PARTS BREAKDOWN**

<i>Section</i>	<i>Page</i>	<i>Section</i>	<i>Page</i>
6. EXPLANATION OF THE PARTS BREAKDOWN .....	6-1	7. MAIN ASSEMBLY PARTS LIST (Continued)	
General .....	6-1	Radio Receiver .....	7-2
Arrangement of Parts Breakdown .....	6-1	Crystal Assembly .....	7-15
How To Use This Parts Breakdown .....	6-2	Radio Frequency Coil .....	7-17
7. MAIN ASSEMBLY PARTS LIST .....	7-1	Audio Selectivity Network Assembly .....	7-18
GPR-90 and GPR-90RX Radio Re- ceivers .....	7-1	8. NUMERICAL INDEX .....	8-1
		9. REFERENCE DESIGNATION INDEX .....	9-1

## LIST OF ILLUSTRATIONS

<i>Figure</i>	<i>Title</i>	<i>Page</i>	<i>Figure</i>	<i>Title</i>	<i>Page</i>
1-1	Radio Receiver Models GPR-90RX and GPR-90 .....	vi	5-5	Radio Receiver Model GPR-90, Schematic Diagram .....	31
1-2	Rear of Receiver Chassis .....	3	5-6	Antenna Circuit, Simplified Schematic Diagram .....	33
1-3	Typical Antenna Installations .....	3	5-7	I-F Selectivity Curves .....	35
1-4	Wiring of Jumper Plug for D-C Operation .....	5	5-8	Audio Response Curves .....	38
1-5	Wiring for Break-in Operation .....	6	7-1	GPR-90 and GPR-90RX Radio Receivers .....	7-1
1-6	ACCESSORY POWER OUT Socket Connections .....	6	7-2	Radio Receiver, Front View (Sheet 1 of 6, Index Nos. 1 thru 39) .....	7-2
2-1	Receiver Front Panel .....	9	7-2	Radio Receiver, Top View (Sheet 2 of 6, Index Nos. 40 thru 134) .....	7-3
4-1	Test Equipment Connections for Audio Gain Test and I-F Alignment .....	20	7-2	Radio Receiver, Back View (Sheet 3 of 6, Index Nos. 135 thru 149) .....	7-4
4-2	Receiver Chassis, Top View .....	21	7-2	Radio Receiver, Bottom View (Sheet 4 of 6, Index Nos. 150 thru 194) .....	7-5
4-3	Test Equipment Connections for R-F Alignment and Sensitivity Test .....	22	7-2	Radio Receiver, Bottom View (Sheet 5 of 6, Index Nos. 195 thru 263) .....	7-6
4-4	Receiver Chassis, Bottom View .....	23	7-2	Radio Receiver, Bottom View (Sheet 6 of 6, Index Nos. 264 thru 308) .....	7-7
5-1	Radio Receiver Models GPR-90RX and GPR-90, Block Diagram .....	26	7-3	Crystal Assembly .....	7-16
5-2	Antenna Circuits and R-F Circuits, Block Diagram .....	26	7-4	Radio Frequency Coil .....	7-17
5-3	Conversion Circuits, Block Diagram .....	27	7-5	Audio Selectivity Network Assembly .....	7-18
5-4	Radio Receiver Model GPR-90RX, Schematic Diagram .....	29			



## LIST OF TABLES

<i>Table</i>	<i>Title</i>	<i>Page</i>	<i>Table</i>	<i>Title</i>	<i>Page</i>
I	Receiver Specifications .....	2		GPR-90RX and GPR-90 .....	14
II	Function of Receiver Controls .....	4	V	Voltage Data .....	19
III	BAND SPREAD Dial Data .....	10	VI	Resistance Data .....	19
IV	Trouble Table for Receiver Models		VII	R-F-Alignment Data .....	24

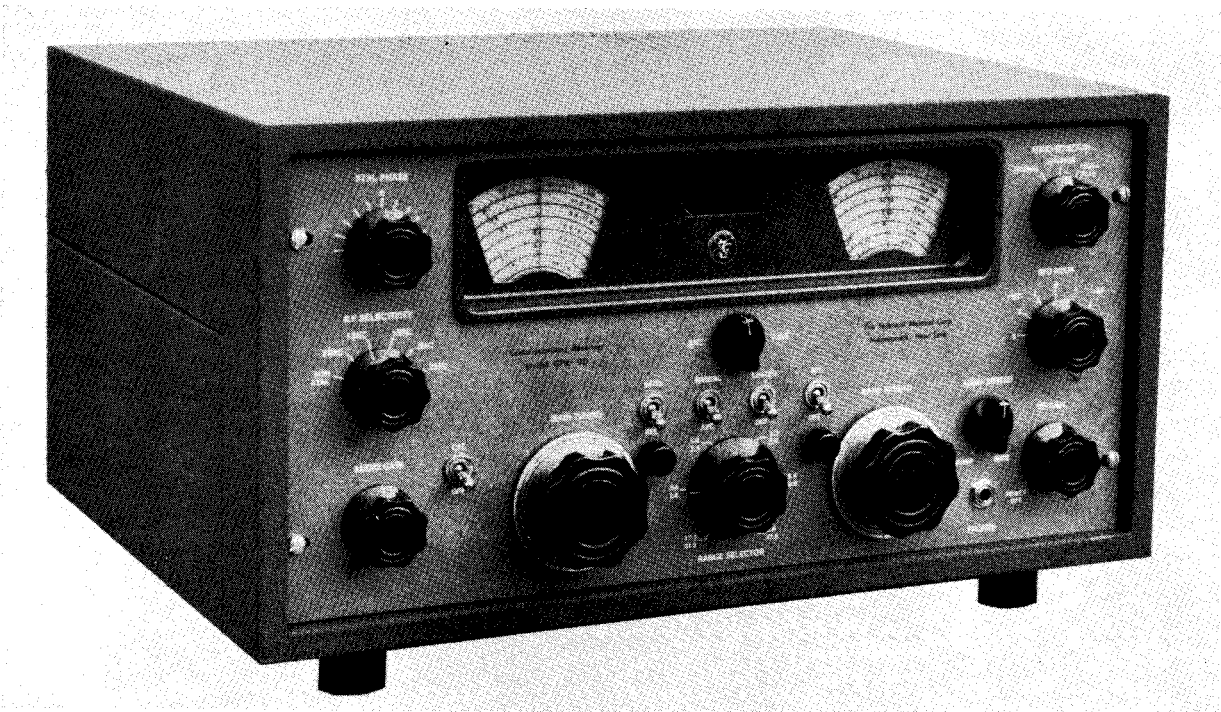

Figure 1-1. Radio Receiver Models GPR-90RX and GPR-90

# I. INITIAL INSTALLATION, USE, AND MAINTENANCE

## SECTION I—FUNCTION, DESCRIPTION, AND INITIAL INSTALLATION

### SUBJECT AND PURPOSE OF THIS HANDBOOK

1-1 Installation, operation, and repair and replacement information for Radio Receiver Models GPR-90RX and GPR-90 (Figure 1-1) is contained in this handbook. The information applies to both receiver models unless otherwise stated.

1-2 The handbook is separated into two main divisions: The first, comprising Sections 1 through 5, contains general descriptive information, as well as installation, operation, and maintenance procedures; the second division, which consists of Sections 6 through 9, is a parts breakdown, and contains location and parts-ordering information for all of the equipment's detail parts.

### FUNCTION OF RECEIVER MODELS GPR-90RX AND GPR-90

1-3 Both the GPR-90RX and GPR-90 are multi-purpose, continuous-coverage communications receivers capable of am., cw, mcw, and single-sideband (ssb) operation in the frequency range of 540 kc to 31.5 mc. The frequency range is divided into six bands, any of which may be selected by a front panel control. Calibrated electrical band spread is provided for amateur operation in the 160-, 80-, 40-, 20-, 15-, 11-, and 10-meter bands. A high impedance PHONO jack makes it possible to operate the audio section of the receivers in conjunction with a record turntable. In addition, an IF OUT jack is provided that enables the receivers to operate with a single-sideband slicer. Two features of model GPR-90RX not contained in model GPR-90 are: (1) a stable, crystal-controlled, high-frequency oscillator with provisions for 10 crystals, and (2) provision for connection to an external, high-frequency oscillator.

### DESCRIPTION OF RECEIVER MODELS GPR-90RX AND GPR-90

#### IDENTIFICATION

1-4 Both receiver models described in this handbook are manufactured by the Technical Materiel Corporation, Mamaroneck, New York. The manufacturer's designations and military nomenclature for the receivers are as follows:

<i>Manufacturer's Designation</i>	<i>Military Nomenclature</i>
Radio Receiver Model GPR-90RX	R-480/URR
Radio Receiver Model GPR-90	R-825/URR

#### PHYSICAL DESCRIPTION

1-5 Receiver model GPR-90RX is 19 inches wide, 10.5 inches high, and 14 inches deep, and weighs 55 pounds. Eight cutouts are provided in the front panel for mounting the receiver in a rack assembly. Model GPR-90 is either cabinet or rack mounted. When cabinet mounted, it is 20 inches wide, 10 inches high, and 15 inches deep. For rack mounting, it is 19 inches wide, 8.75 inches high, and 14 inches deep. The GPR-90 weighs 52 pounds.

#### TABLE OF SPECIFICATIONS

1-6 The principal characteristics of receiver models GPR-90RX and GPR-90 are summarized in Table I.

#### INITIAL INSTALLATION PROCEDURES

1-7 Unpack the receiver carefully, and note any instructions that may accompany it. Make a visual check to determine whether the receiver was damaged during shipment.

**LOCATION**

1-8 Locate the receiver so that it is accessible for inspection and maintenance, and in an area that permits free air circulation through the ventilation holes in the cabinet. If possible, keep the receiver away from excessively warm locations.

**ANTENNA SELECTION AND INSTALLATION**

1-9 The receiver can be operated from a simple, single-wire type of antenna having a length of from 50 to 75 feet, and from half-wave doublets or folded dipoles, which are particularly suitable for operation over a narrow range in the short wave region. Use of coaxial transmission lines with nominal 75-ohm impedance or 300-ohm twin lead for the antenna lead-in provides accurate matching between the antenna and receiver. Any other coaxial line can be used, but at a slight mismatch.

1-10 Connections to the antenna are made at a four-terminal strip at the rear of the receiver (Figure 1-2). If an unbalanced antenna is used, a jumper must be connected between the common and ground terminals. When coaxial transmission line is used, the outer braid must be connected to the ground terminal for both balanced

and unbalanced operation. When 300-ohm twin lead is used, it must be connected directly to the 300-ohm antenna terminals. A grounding strap should be connected between the ground terminal of the antenna strip and a good external ground. Various antenna connections are shown in Figure 1-3.

**SPEAKER INSTALLATION**

1-11 Connect a permanent-magnet type of speaker to the appropriate terminals on the five-terminal strip at the rear of the receiver (Figure 1-2). Output impedances of 4, 8, 16, and 600 ohms are provided.

**POWER SOURCE**

1-12 For a-c operation, plug the receiver power cord into a socket supplying 105 to 125 volts at 50 or 60 cycles. An a-c jumper plug, supplied with the equipment, must be inserted in the AUXILIARY POWER IN socket at the rear of the receiver (Figure 1-2) if the receiver is to be operated from an a-c source.

1-13 For emergency or portable operation, the receiver can be operated from a d-c power source. To do this, remove the a-c jumper plug from the AUXILIARY POWER IN socket, and replace it with a similar jumper plug wired as shown in

**TABLE I**  
**RECEIVER SPECIFICATIONS**

Frequency Range	: 0.54 to 31 mc in six bands.	Selectivity	: Variable in six steps from 250 cycles to 5 kilocycles. One noncrystal position.
Type of Reception	: Capable of am., cw, mcw, and ssb. Frequency shift when used with appropriate type frequency shift converter.	Output Impedance	: 4, 8, 16, and 600 ohms.
Antenna Input Circuit	: Unbalanced 75 ohms and balanced 300 ohms.	Hum Level	: Better than 60 db.
Sensitivity	: Less than 5 microvolts from 0.54 to 1.5 mc, and 1 microvolt for balance of range. All measurements are for 10-db signal-to-noise power ratio.	Output Power	: 2-watts audio output.
Image Ratio	: Better than 60 db.	Input Power for A-C Operation	: 105 to 125 volts, 50/60 cycles, approximately 90 watts.
AVC Characteristics	: With 80-db change in input signal, output remains constant within 12 db.	Input Power for D-C Operation	: "B" supply: 180 to 300 volts, 100 milliamperes. "A" supply: 6 volts, 5 amperes.

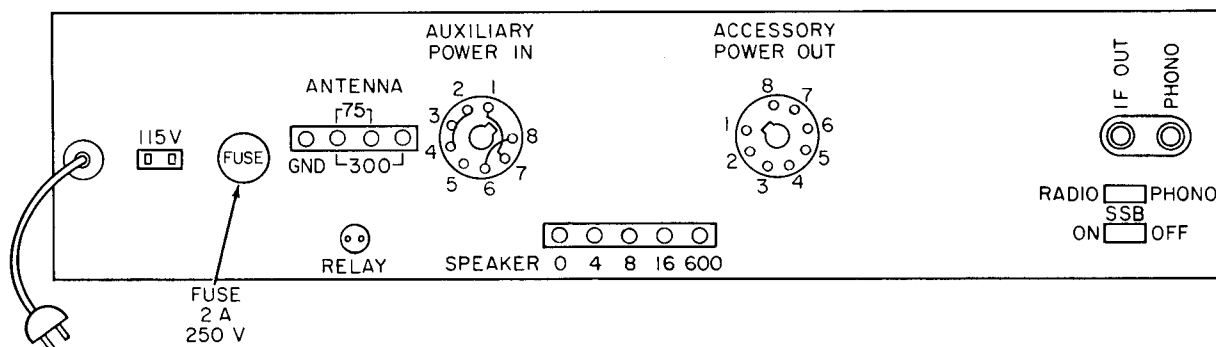

Figure 1-2. Rear of Receiver Chassis

Figure 1-4. For d-c operation, a "B" supply of 180 to 300 volts at 100 milliamperes, and an "A" supply of 6 volts at 5 amperes are required.

#### WIRING FOR BREAK-IN OPERATION

1-14 The receiver may be used for break-in operation with an associated transmitter. For this type of operation, connections must be made between the RELAY socket at the rear of the receiver (Figure 1-2) and an external relay controlled by the transmitter. The contacts used on the relay must be normally closed when the transmitter is de-energized (Figure 1-5). With the relay contacts closed and the receiver SEND-REC switch in the REC position, the receiver operates normally. When the transmitter is energized, the relay contacts open, disabling the receiver.

#### ACCESSORIES

1-15 A 115-volt a-c outlet is provided at the rear of the receiver (Figure 1-2) for operating accessories or test equipment. In addition, 250 volts d-c at 10 milliamperes and 6.3 volts a-c at 0.6 ampere are available at the ACCESSORY POWER OUT socket (Figure 1-6), also at the rear of the receiver.

#### NOTE

When 6.3-volt filament power is used to energize external circuits, make certain receiver filament circuits are kept above chassis ground.

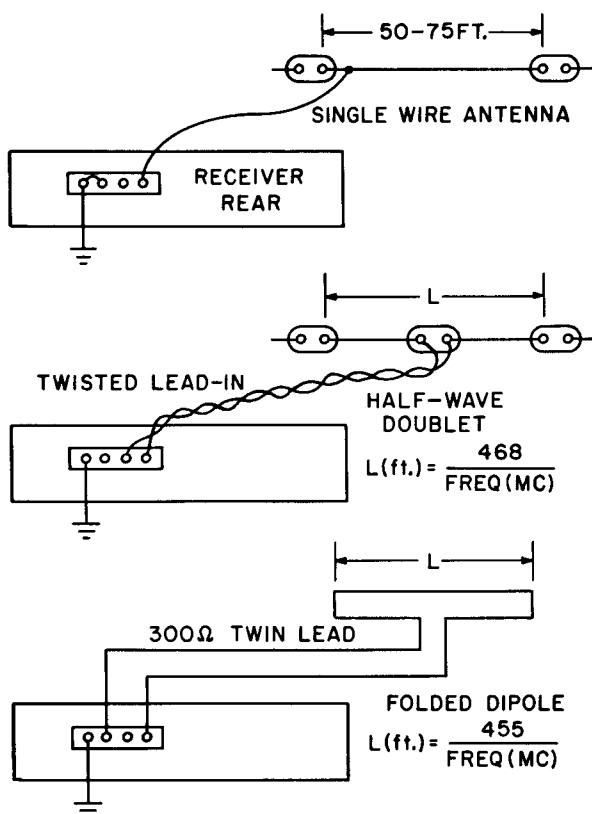

Figure 1-3. Typical Antenna Installations

#### EXTERNAL OSCILLATOR (GPR-90RX only)

1-16 To operate receiver model GPR-90RX with an external high-frequency oscillator, connect a stable oscillator with a 75-ohm output impedance and minimum output of 1 volt to the receiver EXT jack. Make this connection with RG-59/U cable and a UG-260/U connector.

**TABLE II**  
**FUNCTION OF RECEIVER CONTROLS**

Control	Function and Description
RANGE SELECTOR	Selects one of six frequency ranges covered by receiver.
MAIN TUNING	Operates main tuning capacitor through antibacklash gears and drives MAIN TUNING dial, which has six calibrated frequency ranges and an auxiliary logging scale calibrated 0-100. MAIN TUNING dial can be locked by turning locking knob clockwise.
BAND SPREAD	Operates band spread tuning capacitor and is similar in mechanical design to MAIN TUNING control. BAND SPREAD dial contains 160-, 80-, 40-, 20-, 15-, 11-, and 10-meter amateur bands calibrated in frequency. It also has an auxiliary logging scale calibrated 0-100. Control may be locked by turning locking knob clockwise. When locked at minimum capacity (100 on logging scale), MAIN TUNING dial reads correctly.
ANT. TUNE	Operates variable capacitor that trims tuned r-f amplifier under varying load conditions.
RF SELECTIVITY	Controls receiver bandwidth. Receiver selectivity increases (narrow bandwidth) with clockwise rotation of control.
XTAL PHASE	Used to reduce heterodyning or interfering signals by changing null frequency of crystal filter bridge circuit. Inoperative when RF SELECTIVITY control is in NON XTAL position.
AUDIO GAIN	Used to adjust output (volume) to desired listening level.
RF GAIN	Used to turn receiver on and to adjust gain. Clockwise rotation increases receiver gain.
LIMITER-OFF	Used to place noise limiter in operation. Limiter is effective in reducing pulse-type interference riding on signal.
AUDIO SELECTOR	Controls frequency response characteristics of audio circuits. NORMAL position gives essentially flat response and is used for broadcast reception. LOW-PASS position attenuates higher audio frequencies and is used for general communications work. In 1200 ~ PEAK position, audio circuits are highly selective.
AUDIO SPREAD	Varies sharpness of response of audio circuits when AUDIO SELECTOR control is in 1200 ~ PEAK position. Inoperative when AUDIO SELECTOR control is in either NORMAL or LOW-PASS position.
SEND-REC	In SEND position, plate voltage is removed from various receiver stages, making receiver inoperative. Filaments are kept energized so that when switch is placed in REC position, reception is instantly resumed.
MANUAL-AVC	Allows either manual or automatic adjustment of receiver's r-f gain.
BFO-OFF	Used to turn beat frequency oscillator on and off by applying and removing its plate voltage.
BFO PITCH	Used to adjust "beat note" during cw reception, and reinserting carrier during ssb reception. Varies bfo frequency approximately 3 kc on each side of its 455-kc center frequency.

TABLE II. FUNCTION OF RECEIVER CONTROLS (continued)

Control	Function and Description
CAL-OFF	Used to turn 100-kc calibration oscillator on and off by applying and removing its plate voltage.
S meter	Indicates relative signal strength and provides visual means of tuning receiver to incoming signal. Calibrated in S units from 1 to 9, and to +40 db above S-9.
RADIO-PHONO (at rear of receiver)	In RADIO position, receiver functions normally. In PHONO position, receiver is disabled, except for audio circuits, which can be used to amplify output of a record turntable applied at receiver PHONO jack.
SSB (at rear of receiver)	Remains in OFF position, except when single-sideband slicer is used with receiver. In ON position, receiver audio circuits are disabled. With RADIO-PHONO switch in PHONO position and SSB switch in ON position, output of single-sideband slicer can be applied to receiver audio circuits through PHONO jack for increased amplification.
HFO (GPR-90RX only)	In VAR. position, load oscillator is on, permitting variable (normal) operation. In EXT. position, local oscillator is off, permitting use of external oscillator. In XTALS position, high-frequency crystal controlled oscillator is on, and selection can be made of any one of 10 crystals.
XTAL ADJ. (GPR-90RX only)	Allows small changes of crystal frequencies to be made to compensate for tolerance of crystals and drift of transmitter.

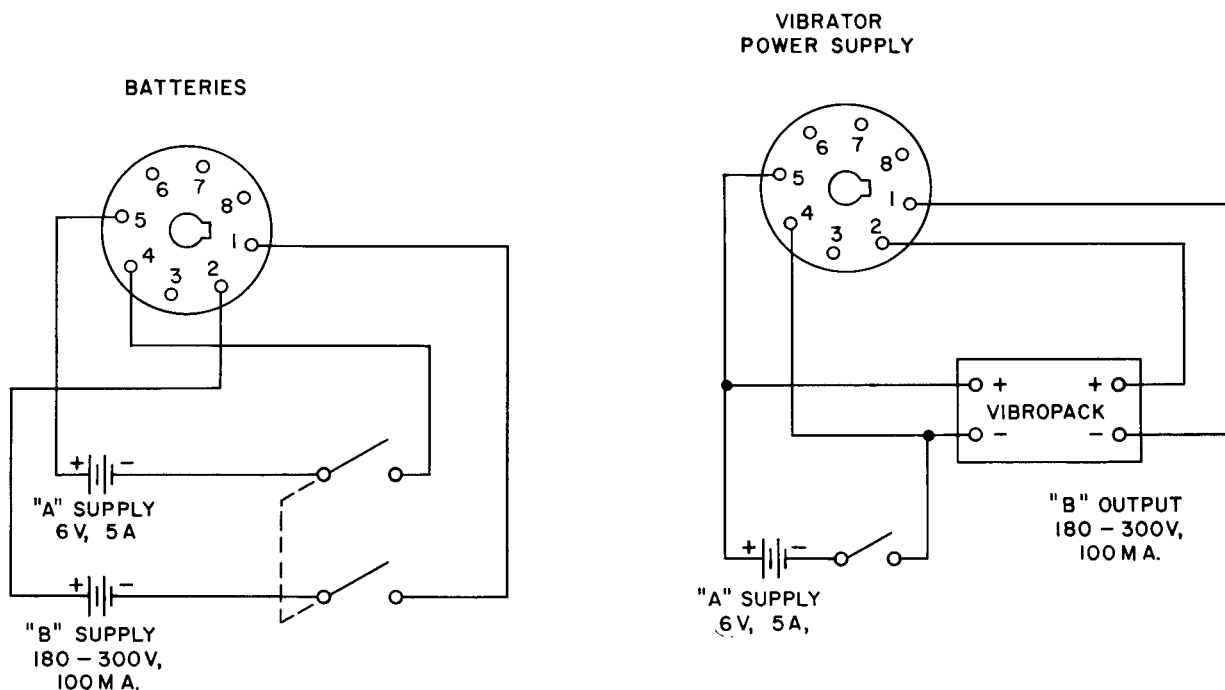

Figure 1-4. Wiring of Jumper Plug for D-C Operation

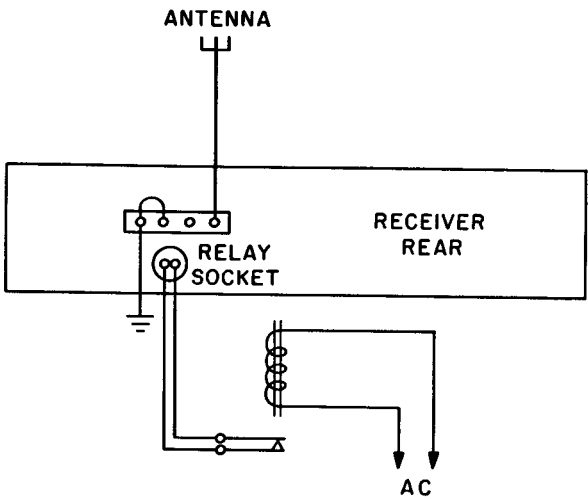

Figure 1-5. Wiring for Break-In Operation

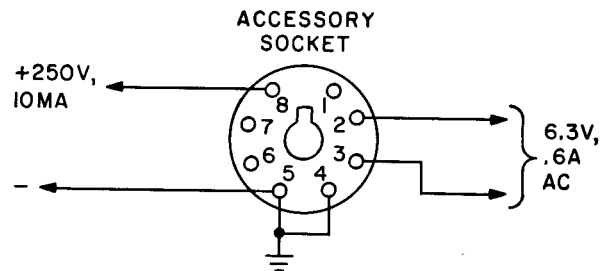

Figure 1-6. ACCESSORY POWER OUT Socket Connections

## SECTION 2

### OPERATING ROUTINES AND METHODS

#### SUBJECT AND PURPOSE OF THIS SECTION

2-1 Procedures for am., mcw, cw, and ssb operation of receiver models GPR-90RX and GPR-90 are covered in this section. In addition, the functions of all receiver controls used during operation are given. For model GPR-90RX only, methods are described for determining the frequencies of the external oscillator and the crystals used with the crystal oscillator. All of the procedures covered must be followed closely to insure optimum receiver performance.

#### TOOLS, APPARATUS, AND MATERIALS

2-2 No tools, apparatus, or materials are necessary for operating the receiver.

#### FUNCTION OF CONTROLS

2-3 The functions of all receiver operating controls are listed in Table II. Unless otherwise indicated, the information applies to both the GPR-90RX and GPR-90. All of the controls are located on the receiver front panel (Figure 2-1), except two, which are at the rear of the receiver (Figure 1-2).

#### OPERATING ROUTINES AND INTERVALS

2-4 No specific operating routines are prescribed for either model GPR-90RX or model GPR-90.

#### PROCEDURES FOR OPERATING RECEIVER MODELS GPR-90RX AND GPR-90

2-5 Unless otherwise indicated, the following operating procedures apply to receiver model GPR-90RX and model GPR-90.

#### OPERATING PROCEDURES FOR AM. AND MCW RECEPTION

2-6 *Communications Operation.*—Perform the following procedures to tune the receiver to all am. and mcw signals, except those in the amateur bands, which can be tuned by means of the BAND SPREAD dial:

a. Set operating controls as follows:

<i>Control</i>	<i>Setting</i>
RANGE SELECTOR	Desired frequency band
MANUAL-AVC	AVC
LIMITER-OFF	OFF
BFO-OFF	OFF
SEND-REC	REC
AUDIO SELECTOR	NORMAL
RF SELECTIVITY	NON XTAL
CAL-OFF	OFF
RADIO-PHONO	RADIO
SSB	OFF
HFO (GPR-90RX only)	VAR.

b. Unlock MAIN TUNING and BAND SPREAD dials by turning dial locks counterclockwise.

c. Set BAND SPREAD dial at 100.

d. Turn RF GAIN control fully clockwise. Tuning and meter dials will be illuminated.

e. Rotate MAIN TUNING control until desired signal is heard, and at the same time advance AUDIO GAIN control until satisfactory listening level is reached.

f. Adjust ANT TUNE control for maximum S-meter deflection.

2-7 *Amateur Operation.*—To tune the receiver over any amateur band by means of the BAND SPREAD dial, refer to Table III and perform the following steps:

a. Set RANGE SELECTOR switch on frequency range covering desired amateur band, and set other operating controls as shown in step a of paragraph 2-6.

b. Turn BAND SPREAD dial to 100.

c. Rotate MAIN TUNING dial until dot indicating upper limit of desired amateur band is behind fiducial line.

d. Set CAL-OFF switch at CAL.

- e. Flip BFO-OFF switch to BFO, and set BFO PITCH control at 0.
- f. Slowly rotate MAIN TUNING dial, in both directions if necessary, until exact zero beat is reached.
- g. Lock MAIN TUNING dial.
- h. Flip CAL-OFF switch to OFF. S meter must dip slightly. If it does not, zero beat of step f was not obtained against calibration oscillator, but against a received signal. Unlock MAIN TUNING dial and repeat steps f and g.
- i. Flip BFO-OFF switch to OFF, unless A1 reception is desired.
- j. Tune in a signal with BAND SPREAD control, and adjust ANT. TUNE control for maximum S-meter deflection.

2-8 *Suppression of Noise Interference.*—When the received signal is accompanied by excessive background noise, other than ignition or pulse-type noise, reception can be improved by increasing receiver r-f selectivity to the point where a phone signal becomes unintelligible. Sometimes it is possible to copy a signal almost obliterated by noise by turning the AUDIO SELECTOR switch to 1200 ~ PEAK and the AUDIO SPREAD control to WIDE. If ignition or pulse-type noise interferes with reception, flip the LIMITER-OFF switch to the LIMITER position.

2-9 *Suppression of Heterodyne Interference.*—If reception is hampered by heterodyne interference, place the RF SELECTIVITY switch in the 2.0KC position and adjust the XTAL PHASE control for maximum attenuation of the interference.

#### OPERATING PROCEDURES FOR CW RECEPTION

2-10 *Initial Control Settings.*—Initial receiver control settings for cw reception are the same as those for am. and mcw reception (paragraph 2-6), except for the following:

Control	Setting
BFO-OFF	BFO
MANUAL-AVC	MANUAL
BFO PITCH	0

2-11 *Tuning CW Signals.*—Tuning procedures for cw signals are the same as those for am. and mcw signals (paragraphs 2-6 and 2-7), with the following exceptions:

- a. For cw reception the receiver's r-f gain is manually controlled.
- b. The desired signal is tuned to zero beat, and

the BFO PITCH control is adjusted for a pleasing audio tone at the receiver output.

2-12 *Suppression of Interference.*—Methods for suppressing noise and heterodyne interference during cw operation are the same as those used for am. and mcw operation (paragraphs 2-8 and 2-9). In the case of cw signals, however, greater degrees of r-f and audio selectivity may be used because of the narrower bandwidth of cw signals.

#### OPERATING PROCEDURES FOR SSB OPERATION

2-13 SSB signals are characterized by carrier absence, unintelligibility, and fluctuation of the S meter. Carrier reinsertion at the receiver is necessary for proper reception. To tune ssb signals, proceed as follows:

- a. Set receiver controls same as for am. and mcw operation (paragraph 2-6).

#### NOTE

If single-sideband slicer is used, place SSB switch in ON position.

- b. Perform operations described in either paragraph 2-6 or 2-7, depending upon desired frequency range.
- c. Flip MANUAL-AVC switch to MANUAL position.
- d. Turn RF GAIN control counterclockwise (reduce gain) until signal is barely audible.
- e. Set BFO PITCH control to 0.
- f. Flip BFO-OFF switch to BFO position.
- g. Turn BFO PITCH control slowly, in both directions if necessary, until signal becomes intelligible. Final setting should be close to 0, and can be on either side, depending on sideband (upper or lower) being transmitted.

#### OPERATING PROCEDURES WHEN USING EXTERNAL OSCILLATOR (GPR-90RX only)

2-14 To operate receiver model GPR-90RX using an external oscillator, perform the following procedures:

- a. Connect external oscillator to receiver EXT jack as explained in paragraph 1-16. Method of determining desired frequency of external oscillator is described in paragraph 2-15.

#### NOTE

When not in use, external oscillator must be turned off or disconnected from receiver.

- b. Depending on type of signal to be received,

tune receiver following procedures given in paragraph 2-6, 2-7, 2-10, or 2-13, making sure that HFO switch is in VAR. position.

- c. Adjust ANT. TUNE control for maximum S-meter deflection.
- d. Place HFO switch in EXT. position.
- e. Retune receiver slightly, if required.

#### FREQUENCY OF EXTERNAL OSCILLATOR (GPR-90RX only)

2-15 The frequency of the external oscillator is determined as follows:

- a. When the frequency of the received signal is between 0.54 and 5.6 mc, the external oscillator frequency is

$$F_o = F_s + 0.455 \text{ mc}$$

where:  $F_o$  = external oscillator frequency, mc

$F_s$  = signal frequency, mc

As an example, for a 1-mc signal the external oscillator frequency would be

$$\begin{aligned} F_o &= 1.000 + 0.455 \\ &= 1.455 \text{ mc} \end{aligned}$$

- b. When the frequency of the received signal is

between 5.6 and 31.5 mc, the external oscillator frequency is

$$F_o = F_s + 3.955 \text{ mc}$$

#### OPERATING PROCEDURES WHEN USING CRYSTAL CONTROLLED HIGH-FREQUENCY OSCILLATOR (GPR-90RX only)

2-16 To operate receiver model GPR-90RX using the crystal controlled high-frequency oscillator, perform the following procedures:

- a. Depending on type of signal to be received, tune receiver following procedures given in paragraph 2-6, 2-7, 2-10, or 2-13, making sure that HFO switch is in VAR. position.
- b. Select desired crystal with HFO switch. Method of determining frequency of crystals to be used is described in paragraph 2-17.
- c. If necessary, trim XTAL ADJ. control.
- d. Retune receiver slightly, if required.

#### FREQUENCY OF CRYSTALS (GPR-90RX only)

2-17 The frequencies of the crystals used with the crystal-controlled, high-frequency oscillator

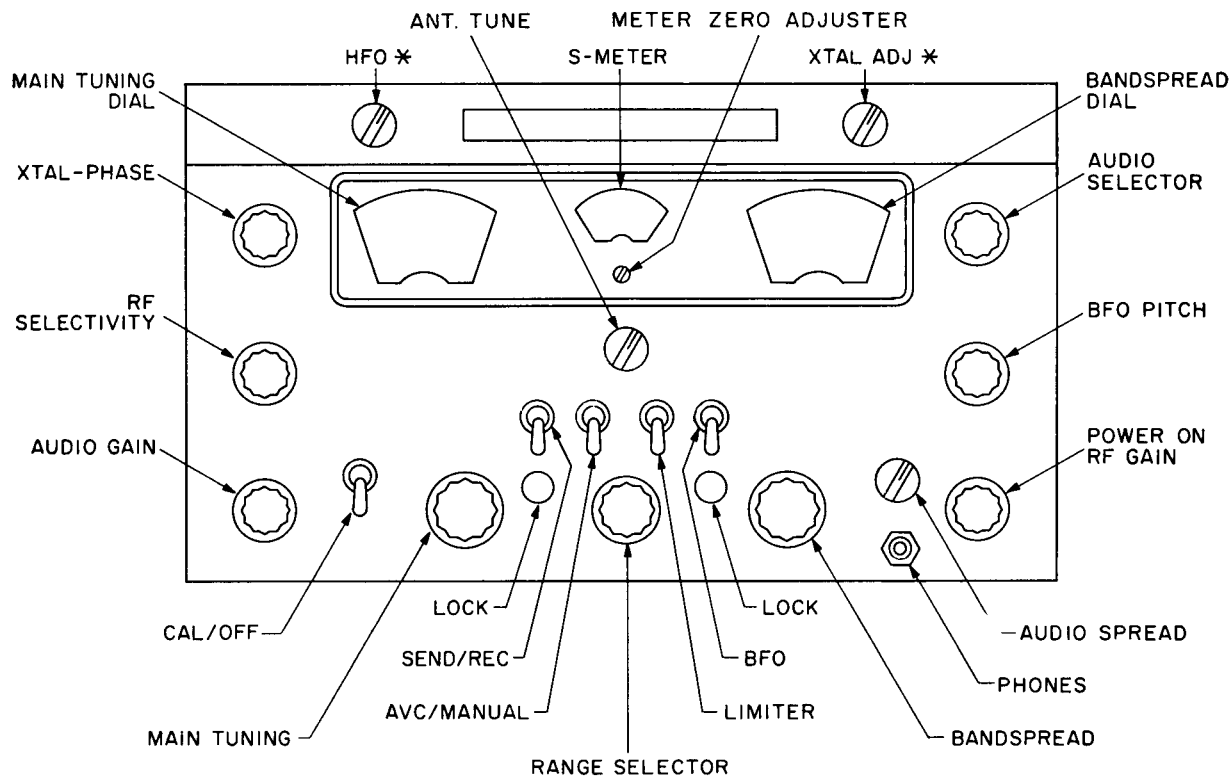

\* ONLY ON GPR-90RX

Figure 2-1. Receiver Front Panel

are determined as follows:

a. When the frequency of the received signal is between 0.54 and 5.6 mc, the oscillator frequency is

$$F_o = F_s + 0.455 \text{ mc}$$

and the required crystal frequency is

$$F_x = 1.00005 (F_o)$$

where:  $F_o$  = oscillator frequency, mc

$F_x$  = crystal frequency, mc

$F_s$  = signal frequency, mc

As an example, for a 1-mc signal the oscillator and crystal frequencies would be

$$F_o = 1.000 + 0.455$$

$$= 1.455 \text{ mc}$$

$$F_x = 1.00005 (1.45500)$$

$$= 1.45507 \text{ mc}$$

b. When the frequency of the received signal is between 5.4 and 16.0 mc, the oscillator frequency is

$$F_o = F_s + 3.955 \text{ mc}$$

and the required crystal frequency is

$$F_x = 1.00005 (F_o)$$

c. When the frequency of the received signal is

between 16.0 and 31.5 mc, the oscillator frequency is

$$F_o = F_s + 3.955 \text{ mc}$$

and the required crystal frequency is

$$F_x = 1.00005 (F_o/2)$$

#### OPERATING PROCEDURES FOR CHECKING CALIBRATION OSCILLATOR

2-18 To check the output frequency of the calibration oscillator, proceed as follows:

- a. Set receiver operating controls as shown in step a of paragraph 2-6.
- b. Turn RF GAIN control clockwise and allow 5-minute warmup period.
- c. Set BAND SPREAD dial at 100 on log scale.
- d. Tune in station WWV (or WWVH) at 5, 10, or 15 mc.
- e. Flip CAL-OFF switch to CAL position.
- f. WWV signal and calibration oscillator signal should produce zero beat at receiver output. If they do not, adjust CAL ADJ control, located on top of receiver chassis (Figure 4-2), until zero beat is heard.

#### NOTE

Best zero beat is obtained during period when tone is removed from WWV carrier.

**TABLE III**  
**BAND SPREAD DIAL DATA**

Band (meters)	Frequency (mc)	Total Spread (degrees)	Total Divisions	kc/div
160	1.8 - 2.0	272	40	5
80	3.5 - 4.0	215	50	10
40	7.0 - 7.3	144	30	10
20	14.0 -14.35	167	35	10
15	21.0 -21.45	100	22	20
11	26.95-27.54	56	11	50
10	28.0 -29.7	132	34	50

## SECTION 3

# PREVENTIVE MAINTENANCE ROUTINES AND METHODS

### SUBJECT AND PURPOSE OF THIS SECTION

3-1 Preventive maintenance routines and the intervals at which they should be performed are described in this section. Methods and techniques for carrying out these routines are also given. All information on preventive maintenance applies to both model GPR-90RX and model GPR-90, unless otherwise specified.

### TOOLS, APPARATUS, AND MATERIALS

3-2 The following items, or equivalents, are required for cleaning the receiver:

Bristle brush;  
Lint-free cloth;  
#0000 sandpaper;  
Vacuum cleaner.

### MAINTENANCE ROUTINES AND INTERVALS

3-3 The recommended schedule of preventive maintenance routines is as follows:

<i>Routine</i>	<i>Interval</i>	<i>Paragraph</i>
Performance check	Weekly	3-4
External visual inspection	Weekly	3-5
Cleaning receiver	Semiannually	3-6

### PREVENTIVE MAINTENANCE PROCEDURES FOR RECEIVER MODELS GPR-90RX AND GPR-90

#### PERFORMANCE CHECK

3-4 Check receiver operation in all modes, am., mcw, cw, and ssb, by tuning in actual signals. In addition, if practicable, check the operation of model GPR-90RX when using an external oscillator, as well as when using the crystal-controlled, high-frequency oscillator. When making these checks, use the receiver operating procedures de-

scribed in Section 2. If, during any of the checks, the receiver does not function properly, refer to the corrective maintenance procedures covered in Section 4.

#### EXTERNAL INSPECTION

3-5 Inspect the exterior of the receiver as follows:

- Inspect all exposed metal surfaces for rust, corrosion, and moisture.
- Inspect cords, cables, and wires for cuts, breaks, fraying, deterioration, kinks, and strain.
- Inspect switches, knobs, jacks, and connectors for looseness.
- Inspect controls for binding, scraping, and positive action.
- Inspect meter and dial faces for damage.

#### CLEANING

3-6 Clean the receiver internally and externally as follows:

#### WARNING

Disconnect power from receiver before cleaning internally.

- Remove corrosion using #0000 sandpaper.
- Remove dirt, dust, grease, and grime with clean, dry, lint-free cloth or bristle brush. When cleaning surfaces that perform no electrical function, cloth or brush may be moistened with cleaning solvent.
- Use vacuum cleaner to remove rust from inaccessible places.



## SECTION 4

# ADJUSTMENTS AND REPLACEMENTS

### SUBJECT AND PURPOSE OF THIS SECTION

4-1 Corrective maintenance procedures, including alignment, adjustment, and calibration procedures, are described in this section. Unless otherwise indicated, all procedures apply to both model GPR-90RX and model GPR-90. When necessary during corrective maintenance, refer to the overall receiver schematic diagrams included in Section 5.

### TOOLS, APPARATUS, AND MATERIALS

4-2 The following apparatus and test equipments, or equivalents, are required for corrective maintenance:

HF Signal Generator, Trad SG-25;  
A-C VTVM, Hewlett-Packard 400D;  
Audio Oscillator, Hewlett-Packard 200CD;  
A-C/D-C VTVM, Hewlett-Packard 410B;  
Multimeter, Western Electric KS-14510;  
Tube Tester, Western Electric KS-15750 L-2;  
Audio load, 560-ohm  $\pm 10\%$ , 2-watt resistor;  
Dummy antenna, 50-ohm resistor.

### CORRECTIVE MAINTENANCE PROCEDURES

#### TROUBLE ANALYSIS METHODS

4-3 Before troubleshooting procedures can be carried out on a malfunctioning receiver, it must be determined that the trouble is in the receiver and not external to it. In many cases it may be obvious that the receiver is defective. Sometimes, however, it is not at all obvious, and to immediately begin troubleshooting the receiver will result in wasted time. In these cases, the following steps should be performed prior to troubleshooting:

- a. Check that the input power to the receiver is normal.
- b. Check that the antenna and transmission line are not defective. This can be done by connecting the receiver to another antenna, if one is available.
- c. Tune in other signals to make sure the trouble is not at the transmitting station.
- d. If the receiver is used for break-in operation

with an associated transmitter, make sure the trouble is not in the transmitter or in the wiring between the transmitter and receiver.

### PRELIMINARY TROUBLESHOOTING PROCEDURES

4-4 *Inspection by Sight, Hearing, and Smell.*—Preliminary examination of the receiver by use of the senses is sometimes helpful in locating receiver troubles. Visual inspection includes checking for improperly connected cables, blown fuses, burned-out tubes, broken cords or plugs, tripped circuit breakers, burned-out resistors, arcing, and smoke. In addition, all switches and controls must be inspected to determine that they have been set to the proper positions.

4-5 The sense of smell can be used to detect the odor of burned insulation, charred resistors, and an overheated transformer. Hearing is useful for detecting arcing between wires or between wires and the chassis, as well as the "cooking" of an overloaded or overheated transformer.

4-6 *Checking Electron Tubes.*—Since most receiver troubles are caused by burned-out or defective electron tubes, the first actual step in troubleshooting is to check the tubes. Sometimes only one or two tubes have to be checked, such as when the receiver malfunctions only when the bfo or 100-kc calibration oscillator is used. For other troubles, such as low receiver gain, however, most of the tubes must be checked.

4-7 When using a tube tester, turn off the receiver power and remove and test the tubes one at a time. Substitute new tubes only for those that are shown to be definitely defective. If a tube is suspected of having an intermittent defect, tap the tube gently while checking it.

4-8 If a replacement for a bad tube becomes defective immediately after being inserted into the receiver, a detail part in that circuit is probably defective. Voltage and resistance measurements (paragraphs 4-11 and 4-12) and continuity checks should be made of that circuit to locate the faulty part.

**MINIMUM PERFORMANCE CHECK**

4-9 For troubleshooting purposes, it may sometimes be desirable to determine whether the receiver is operating at or above its minimum specified performance ratings. This can be checked by performing the receiver gain tests covered in paragraphs 4-13, 4-14, and 4-15.

**TROUBLE TABLE**

4-10 Step-by-step troubleshooting procedures are given in Table IV. When using this table, start at Step 1 and proceed in sequence. If the indication in the "Trouble" column does not apply, skip that step and go on to the next.

**NOTE**

Use Table IV only after it has been determined that the trouble is in the receiver (paragraph 4-3) and after

electron tubes have been checked (paragraph 4-6).

Before proceeding with "Step 1" of Table IV, set the receiver operating controls as follows:

<i>Control</i>	<i>Setting</i>
RANGE SELECTOR	.54—1.4
RF SELECTIVITY	NON XTAL
RF GAIN	fully clockwise
LIMITER-OFF	OFF
AUDIO SELECTOR	NORMAL
MANUAL-AVC	MANUAL
BFO-OFF	OFF
CAL-OFF	OFF
HFO (GPR-90RX only)	VAR.
SEND-REC	REC
RADIO-PHONO	RADIO
SSB	OFF

Leave all controls in the above positions unless otherwise indicated in the table.

**TABLE IV**  
**TROUBLE TABLE FOR RECEIVER MODELS GPR-90RX AND GPR-90**

Step	Trouble	Probable Cause	Remedy
1	Electron tube filaments and tuning dials not lit up.	Blown fuse.	Replace fuse F1. Use 2-ampere fuse.
		Switch S10 defective.	Check switch and replace, if necessary.
		Primary winding or 6.3-volt secondary winding of transformer T10 defective.	Check continuity of windings and replace T10, if necessary.
2	Fuse blows repeatedly when replaced.	B-plus filter capacitor C104-A or C104-B or secondary of transformer T10 shorted.	Make resistance check and replace capacitor or transformer, if necessary.
		B-plus line shorted.	Make resistance check (paragraph 4-12) and continuity check, and correct short or replace defective part.
3	Receiver operates, but tuning dials not lit up.	Tuning dial lamps I1, I2, or I3 burned out.	Replace burned out lamps.
4	Signals at high or low end of band weak. All other signals normal.	Receiver out of alignment.	Align r-f section of receiver (paragraph 4-20).

TABLE IV. TROUBLE TABLE FOR RECEIVER MODELS GPR-90RX AND GPR-90 (continued)

Step	Trouble	Probable Cause	Remedy
5	Signals throughout band either weak or cannot be received at all.	Low or no receiver gain.	Proceed with steps 20 through 23.
6	S meter not indicating properly.	Improper calibration.  Defective S meter or trouble in S-meter circuit.	Calibrate S meter (paragraph 4-23).  Make continuity and resistance check of S-meter coil and circuit. Replace meter or resistor R46, R49, R50, or R51, if defective.
7	Hum in receiver output.	Improper hum balance adjustment.  Hum balance resistor R94 defective.  B-plus filter capacitor C104-A or C104-B, or bypass capacitor C105, C107, C119, C132, or C133 in 6.3 V a-c line defective.	Make hum balance adjustment (paragraph 4-22).  Make resistance check and replace, if necessary.  Replace defective capacitor.
8	Distortion in receiver output.	Poor frequency response.	Proceed with steps 24 and 25.
9	AVC does not function properly.	MANUAL-AVC switch S3 or other detail part in avc line defective.	Make voltage and resistance checks (paragraphs 4-11 and 4-12) and continuity checks. Replace switch S3, capacitor C68, C69, or C70, or resistor R63, R64, R65, or R66, if defective.
10	Excessive noise in output signal (LIMITER-OFF switch in LIMITER position).	LIMITER-OFF switch S4 defective.	Make continuity check and replace S4, if necessary.
11	Receiver audio selectivity cannot be varied by AUDIO SELECTOR switch or AUDIO SPREAD control.	AUDIO SELECTOR switch or other detail part in audio selectivity circuit defective.	Make resistance and continuity check. Replace switch S5, capacitor C72, C74, or C77, resistor R71, R72, or R76, or coil L21, if defective.
12	Receiver does not function properly when bfo is used.	BFO-OFF switch S8 or other detail part in bfo circuit defective.	Make voltage and resistance checks (paragraphs 4-11 and 4-12) and continuity check, and replace defective part.

TABLE IV. TROUBLE TABLE FOR RECEIVER MODELS GPR-90RX AND GPR-90 (continued)

Step	Trouble	Probable Cause	Remedy
13	Calibration oscillator cannot zero beat with station WWV.	Crystal Y3.	Replace crystal.
		CAL-OFF switch S11 or other detail part in calibration oscillator circuit defective.	Make voltage and resistance checks (paragraphs 4-11 and 4-12) and continuity check. Replace switch S11, capacitor C106, C134, C135, C136, or C137, or resistor R77, R95, R96, or R97, if defective.
14	RF SELECTIVITY control does not vary receiver selectivity properly.	Crystal Y1 defective.	Replace crystal.
		RF SELECTIVITY switch S2 or other detail part in crystal filter circuit defective.	Make continuity checks and replace defective part.
15	Receiver functions properly in bands 1, 2, and 3, but malfunctions in bands 4, 5, and 6.	Defective part in circuit of second converter and oscillator V4.	Make voltage and resistance checks (paragraphs 4-11 and 4-12) and continuity check, and replace defective part.
16	Receiver malfunctions in only one band.	Defective part or wiring connected into circuit only when RANGE SELECTOR switch is in that band.	Make continuity check of parts and wiring used only in that band, and replace defective part or wiring.
17 (GPR-90RX only)	Receiver malfunctions when crystal-controlled, high-frequency oscillator is used.	One of crystals Y4 through Y13 defective.	Replace crystal.
		HFO switch S12 or detail part in oscillator circuit defective.	Make voltage and resistance checks (paragraphs 4-11 and 4-12) and continuity check, and replace defective part.
18 (GPR-90RX only)	Receiver malfunctions when external oscillator is used.	HFO switch S12, EXT jack J5, resistor R104, or connection between external oscillator and J5 defective.	Make continuity check and replace defective part.

TABLE IV. TROUBLE TABLE FOR RECEIVER MODELS GPR-90RX AND GPR-90 (continued)

Step	Trouble	Probable Cause	Remedy
19	No output from PHONES jack.	PHONES jack J2 or resistor R75 defective.	Make continuity check and replace defective part.
20	Power supply output voltages incorrect.	Transformer T1 or other detail part in power supply defective.	Make voltage and resistance checks (paragraphs 4-11 and 4-12) and continuity checks. Replace transformer T1, capacitor C104, resistor R87, or coil L23, if defective.
21	Low or no audio gain (paragraph 4-13).	Detail part in audio circuits defective.	Make voltage and resistance checks (paragraphs 4-11 and 4-12) and continuity checks, and replace defective part.
22	Low or no i-f gain (paragraph 4-14).	Detail part in i-f circuits defective.	Make voltage and resistance checks (paragraphs 4-11 and 4-12) and continuity checks, and replace defective part.
		I-F circuits out of alignment.	Align i-f section of receiver (paragraph 4-16).
23	Low or no r-f gain (paragraph 4-15).	Detail part in r-f circuits defective.	Make voltage and resistance checks (paragraphs 4-11 and 4-12) and continuity checks, and replace defective part.
		R-F circuits out alignment.	Align r-f section of receiver (paragraph 4-20).
24	Poor audio response.	Detail part in audio circuits defective.	Make voltage and resistance checks (paragraphs 4-11 and 4-12) and continuity checks, and replace defective part.
25	Improper i-f selectivity.	Detail part in i-f circuits defective.	Make voltage and resistance checks (paragraphs 4-11 and 4-12) and continuity checks, and replace defective part.

**VOLTAGE MEASUREMENTS**

4-11 Receiver voltage data are shown in Table V. All voltages are with respect to chassis ground, except the 6.3 V a-c filament voltages, which are measured across the filament pins of the tubes.

**NOTE**

Voltage values in Table V were taken on prototype receiver, and  $\pm 10$  percent variation is to be expected.

When the voltage at a pin is incorrect, refer to the receiver over-all schematic diagram, and make resistance and continuity checks of the detail parts common to that pin. Before making any voltage measurements, set the receiver controls as follows:

<i>Control</i>	<i>Setting</i>
RF GAIN	fully clockwise
MANUAL-AVC	AVC
LIMITER-OFF	OFF
BFO-OFF	BFO
SEND-REC	REC
AUDIO SELECTOR	NORMAL
RANGE SELECTOR	as shown in Table V
HFO (GPR-90RX only)	VAR.

**RESISTANCE MEASUREMENTS**

4-12 Receiver resistance data are shown in Table VI. All resistances are given in ohms with respect to chassis ground, except for measurements taken between the tube filament pins.

**NOTE**

Resistance values in Table VI were taken on prototype receiver, and  $\pm 10$  percent variation is to be expected.

Before making any resistance measurements, remove the receiver power cord from the power socket, and set the receiver controls as follows:

<i>Control</i>	<i>Setting</i>
RF GAIN	fully clockwise
AUDIO GAIN	fully clockwise
LIMITER-OFF	OFF
MANUAL-AVC	MANUAL
SEND-REC	REC
AUDIO SELECTOR	NORMAL
BFO-OFF	OFF
RANGE SELECTOR	.54—1.4
MAIN TUNING	capacitor half-open
HFO (GPR-90RX only)	VAR.

**AUDIO GAIN TEST**

4-13 To determine whether the audio gain of the receiver is normal, proceed as follows:

a. Plug audio oscillator into PHONO jack at rear of receiver, and connect 560-ohm audio load and a-c vtvm in parallel across 600-ohm speaker terminals (Figure 4-1).

b. Set receiver controls as follows:

<i>Control</i>	<i>Setting</i>
RADIO-PHONO	PHONO
AUDIO SELECTOR	NORMAL
AUDIO GAIN	fully clockwise
RF GAIN	fully clockwise

c. Set audio oscillator output at 1000 cps, and adjust signal level to produce 34.6-volt reading on vtvm.

d. Remove vtvm from across 600-ohm speaker terminals and connect it across audio oscillator output terminals; vtvm should read approximately 0.3 volt.

e. Repeat steps c and d with AUDIO SELECTOR switch in LOW-PASS position. Audio oscillator output should be approximately 0.3 volt.

f. Repeat steps c and d with AUDIO SELECTOR switch in 1200 ~ peak position and AUDIO SPREAD control adjusted for maximum receiver output. Audio oscillator output should be approximately 0.18 volt.

**IF-GAIN TEST**

4-14 To determine whether the receiver i-f gain is normal, proceed as follows:

a. Set receiver controls as follows:

<i>Control</i>	<i>Setting</i>
RF GAIN	fully counterclockwise (power off)
RF SELECTIVITY	NON XTAL
XTAL PHASE	0
BFO-OFF	OFF
BFO-PITCH	0
AUDIO GAIN	fully counterclockwise
CAL-OFF	OFF
MANUAL-AVC	AVC
LIMITER OFF	OFF
ANT. TUNE	mid-position
SEND-REC	REC
RADIO-PHONO	RADIO
HFO (GPR-90RX only)	VAR.

b. As shown in Figure 4-2, ground one lug of main tuning capacitor and connect output lead from hf signal generator to other.

**TABLE V**  
**VOLTAGE DATA**

Electron Tube	Range Selector Setting	Socket Pin Numbers							
		1	2	3	4	5	6	7	8
V1-6AB4	9.4—17.8	130	0	6.3*	6.3*	130	0	1.2	—
V2-6CB6	1.4— 3.3	0	2.5	6.3*	6.3*	230	135	2.5	—
V3-6AU6	1.4— 3.3	0	0	6.3*	6.3*	250	85	3.0	—
V4-6BE6	9.4—17.8	-1.3	0	6.3*	6.3*	250	50	0	—
V5-6BA6	1.4— 3.3	0	1.5	6.3*	6.3*	250	50	1.5	—
V6-6BA6	1.4— 3.3	-0.4	1.8	6.3*	6.3*	200	80	1.8	—
V7-6BA6	1.4— 3.3	-0.4	1.8	6.3*	6.3*	200	80	1.8	—
V8-6BA6	1.4— 3.3	0	1.8	6.3*	6.3*	200	80	1.8	—
V9-6AL5	1.4— 3.3	0	-1.5	5*	5*	-1.5	0	-2.3	—
V10-12AX7	1.4— 3.3	-0.45	-0.45	2.0	6.3*	6.3*	140	-0.6	1.3
V11-6V6	1.4— 3.3	NC	6.3*	240	260	0	NC	6.3*	0
V12-6AG5	1.4— 3.3	-0.8	0	6.3*	6.3*	140	130	0	—
V13-6AG5	1.4— 3.3	-1.5	NC	6.3*	6.3*	40	15	0	—
V14-504-G	1.4— 3.3	NC	300	NC	240*	NC	240*	—	300
V15-OA2	1.4— 3.3	150	NC	NC	NC	NC	NC	0	—
V16-6CB6	CAL-OFF to CAL	-45	9.0	6.3*	6.3*	70	80	0	—
V17-6AG5 (GPR-90RX only)	—	0	0.8	6.3*	6.3*	70	90	—	—

\* A-C voltage; all others dc. NC = no connection

**TABLE VI**  
**RESISTANCE DATA**

Electron Tube	Range Selector Setting	Socket Pin Numbers							
		1	2	3	4	5	6	7	8
V1-6AB4	9.4—17.8	50 k	0	0	0	50 k	3 meg	220	—
V2-6CB6	1.4— 3.3	3 meg	260	0	0	50 k	100 k	260	—
V3-6AU6	1.4— 3.3	2.2 meg	0	0	0	50 k	200 k	3 k	—
V4-6BE6	9.4—17.8	15 k	0	0	0	50 k	70 k	47	—
V5-6BA6	1.4— 3.3	2	510	0	0	50 k	180 k	510	—
V6-6BA6	—	4 meg	220	0	0	50 k	140 k	220	—
V7-6BA6	—	3 meg	220	0	0	40 k	35 k	220	—
V8-6BA6	—	22	220	0	0	55 k	100 k	220	—
V9-6AL5	—	0	500 k	2	0	500 k	0	750 k	—
V10-12AX7	—	1.2 meg	1.2 meg	4.5 k	0	0	100 k	8.2 meg	200
V11-6V6	—	NC	0	50 k	50 k	470 k	0	0	—
V12-6AG5	—	22 k	0	0	—	45 k	NC	0	—
V13-6AG5	—	47 k	0	0	—	130 k	65 k	0	—
V14-5U4-G	—	—	50 k	NC	70	NC	100 k	NC	50k
V15-OA2	—	50 k	—	—	—	50 k	70	—	—
V16-6CB6	CAL-OFF to CAL	0.5 meg	6.8 k	0	0	50 k	50 k	0	—
V17-6AG5 (GPR-90RX only)	—	120	120	0	0	70 k	80 k	—	—

k = 1000 meg = 1,000,000 NC = no connection

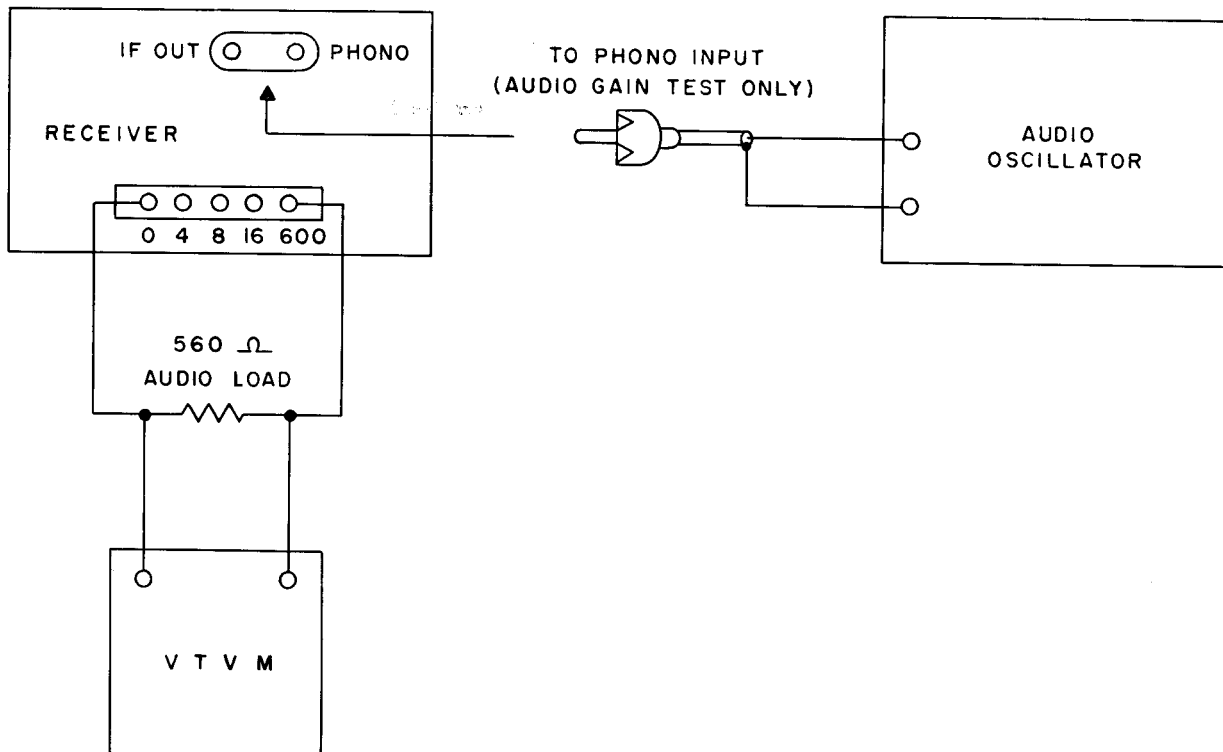

Figure 4-1. Test Equipment Connections for Audio Gain Test and I-F Alignment

- c. Adjust signal generator for 30-microvolt output at 455 kc, modulated 30 percent with 1000 cps.
- d. Connect a-c probe of Hewlett-Packard 410B vtvm at junction of resistors R58, R59, and R60, and connect ground lead of vtvm to receiver chassis.
- e. Turn on receiver power. Voltmeter should read 0.35 volt minimum.
- f. Remove a-c probe from junction of resistors and insert it in IF OUT jack at rear of receiver. Voltmeter should read 0.7 volt minimum.
- g. Adjust signal generator for 30-microvolt output at 3.955 mc, modulated 30 percent with 1000 cps. Voltmeter should read 0.65 volt minimum.

#### RF-GAIN TEST

4-15 Use the following procedures to check over-all receiver sensitivity. When the over-all receiver sensitivity test is performed after the audio and if-gain tests, it serves as an rf-gain test.

- a. Connect signal generator, dummy antenna resistor, 560-ohm audio load, and a-c vtvm as shown in Figure 4-3.

- b. Set receiver controls as follows:

<i>Control</i>	<i>Setting</i>
RANGE SELECTOR	.54-1.4
RF SELECTIVITY	NON XTAL
XTAL PHASE	0
BFO-OFF	OFF
BFO PITCH	0
AUDIO GAIN	fully counter-clockwise
CAL-OFF	OFF
MANUAL-AVC	AVC
LIMITER-OFF	mid-position
SEND-REC	REC
RADIO-PHONO	RADIO
HFO (GPR-90RX only)	VAR.
RF GAIN	fully clockwise

- c. Set and lock BAND SPREAD dial on 100, and set MAIN TUNING dial at middle frequency of band 1.
- d. Adjust signal generator for output frequency indicated on MAIN TUNING dial (step c), modulated 30 percent with 1000 cps at a level of 2.5 microvolts.
- e. Adjust receiver AUDIO GAIN control for reading of approximately 15 volts on vtvm. Record vtvm reading.

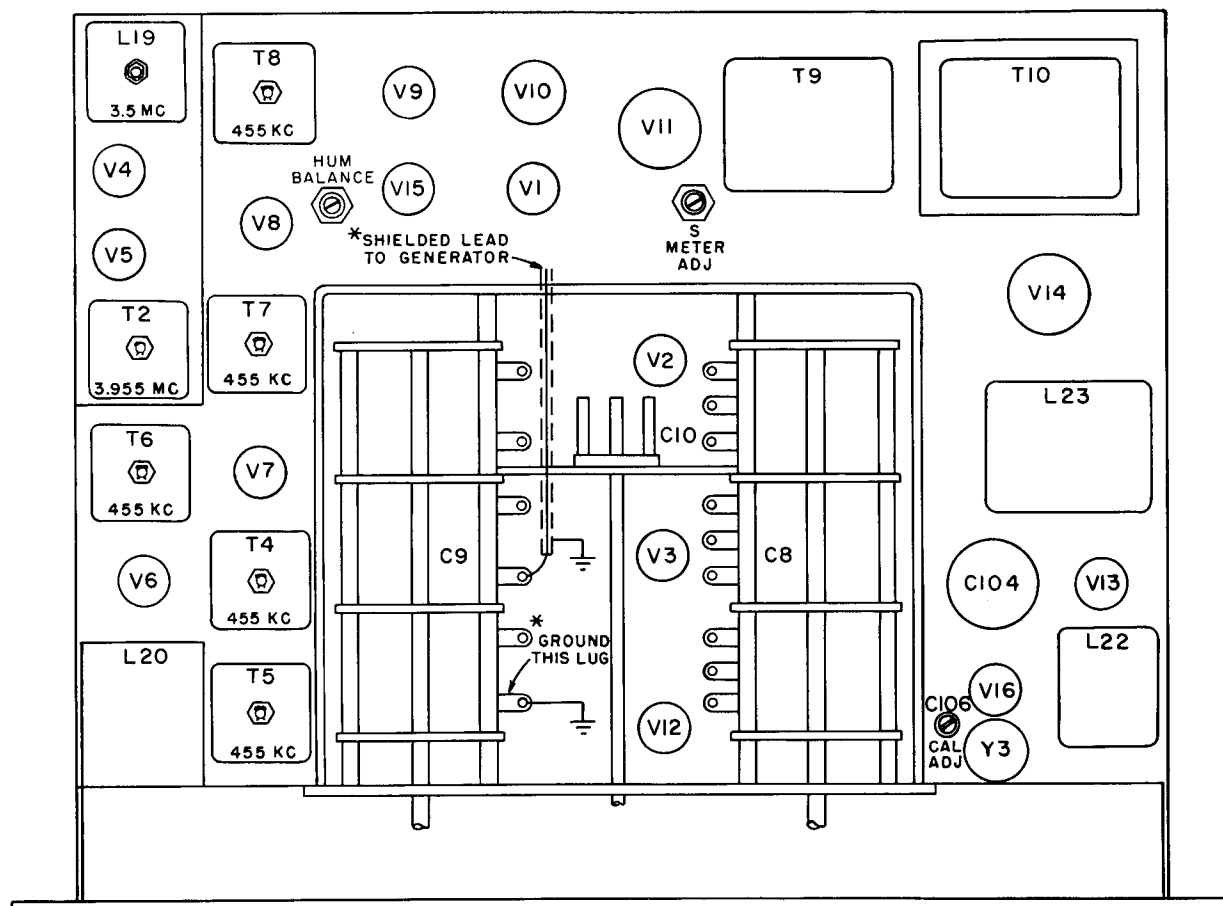

Figure 4-2. Receiver Chassis, Top View

f. Remove modulation from signal generator, keeping output level constant.

g. Record drop in vtm reading. This drop is signal-to-noise ratio, and should be 10 db or more.

h. Repeat steps c through g for bands 2 through 6. However, for these bands, use signal generator output level of 2 microvolts instead of 2.5 microvolts. Signal-to-noise ratio for each band should be 10 db or more.

#### IF-ALIGNMENT PROCEDURES

4-16 Receiver i-f alignment includes alignment of the 455-kc if., the 3.955-mc if., and the bfo. The following steps are performed prior to actual i-f alignment:

a. Remove dust cover from tuning capacitor shield compartment.

b. As shown in Figure 4-2, ground one lug of main tuning capacitor and connect output lead from signal generator to other.

c. Connect 560-ohm audio load and a-c vtm in parallel across 600-ohm speaker terminals (Figure 4-1).

d. Set receiver controls as follows:

Control	Setting
RANGE SELECTOR	.54-1.54
MANUAL-AVC	MANUAL
LIMITER-OFF	OFF
BFO-OFF	OFF
SEND-REC	REC
AUDIO SELECTOR	NORMAL
AUDIO GAIN	fully clockwise
MAIN TUNING	mid-position
XTAL PHASE	0
HFO (GPR-90RX only)	VAR.
RF GAIN	fully clockwise

4-17 455-KC Alignment.—To align the 455-kc if., proceed as follows:

a. Set RF SELECTIVITY control at NON XTAL position and adjust signal generator for output of 455 kc, modulated 30 percent with 400 cps.

b. Adjust amplitude of signal generator output until some deflection of vtm is noted.

c. In order, adjust i-f transformers T8, T7, T6, coil L20, and i-f transformers T5 and T4 (Figures 4-2 and 4-4) for maximum reading on vtm.

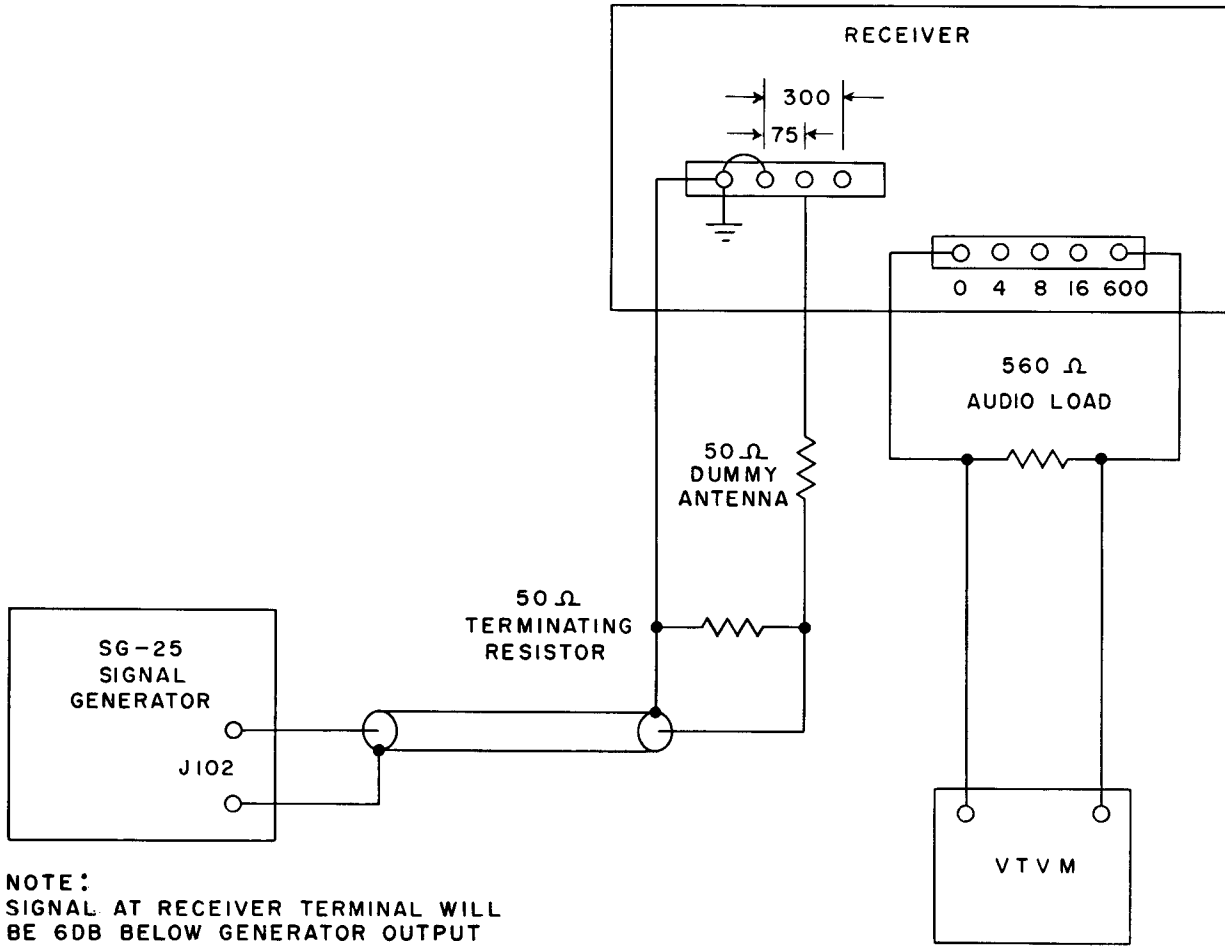

NOTE:  
SIGNAL AT RECEIVER TERMINAL WILL  
BE 6DB BELOW GENERATOR OUTPUT

Figure 4-3. Test Equipment Connections for R-F Alignment and Sensitivity Test

Transformers T8, T7, T6, and T5 are adjusted at both top and bottom; T4 and L20 are adjusted at bottom only.

**NOTE**

During alignment, signal generator output should be progressively reduced to prevent overloading receiver.

d. Turn RF SELECTIVITY switch to 2.0KC position and adjust signal generator frequency for maximum deflection of vtvm.

**NOTE**

Do not change signal generator output frequency for remainder of 455-kc alignment and for bfo alignment.

e. Repeat step c.

4-18 BFO Alignment.—Align the bfo after alignment of the 455-kc if. Proceed as follows:

- a. Remove modulation from signal generator output signal and set BFO PITCH control at 0.
- b. Flip BFO-OFF switch to BFO.

c. Plug headphones into PHONES jack and adjust coil L22 (Figure 4-4) for zero beat.

4-19 3.955-MC Alignment.—After the bfo has been aligned, align the 3.955-mc if. as follows:

- a. Turn RANGE SELECTOR switch to 5.4-9.6 position and adjust signal generator for output of 3.955 mc, modulated 30 percent at 400 cps.
- b. Adjust coil L19 (Figure 4-2) until some deflection of vtvm is noted.
- c. Switch receiver off momentarily and then turn it back on. If vtvm still deflects, L19 is set correctly. If no deflection occurs, repeat step b.

**NOTE**

Step c is necessary because adjustment of L19 permits 3.5-mc, crystal-controlled oscillator to operate over a small frequency range, and for stable operation, L19 must be set for center of range.

d. In order, adjust i-f transformers T3 and T2 (Figures 4-2 and 4-4) for maximum deflection

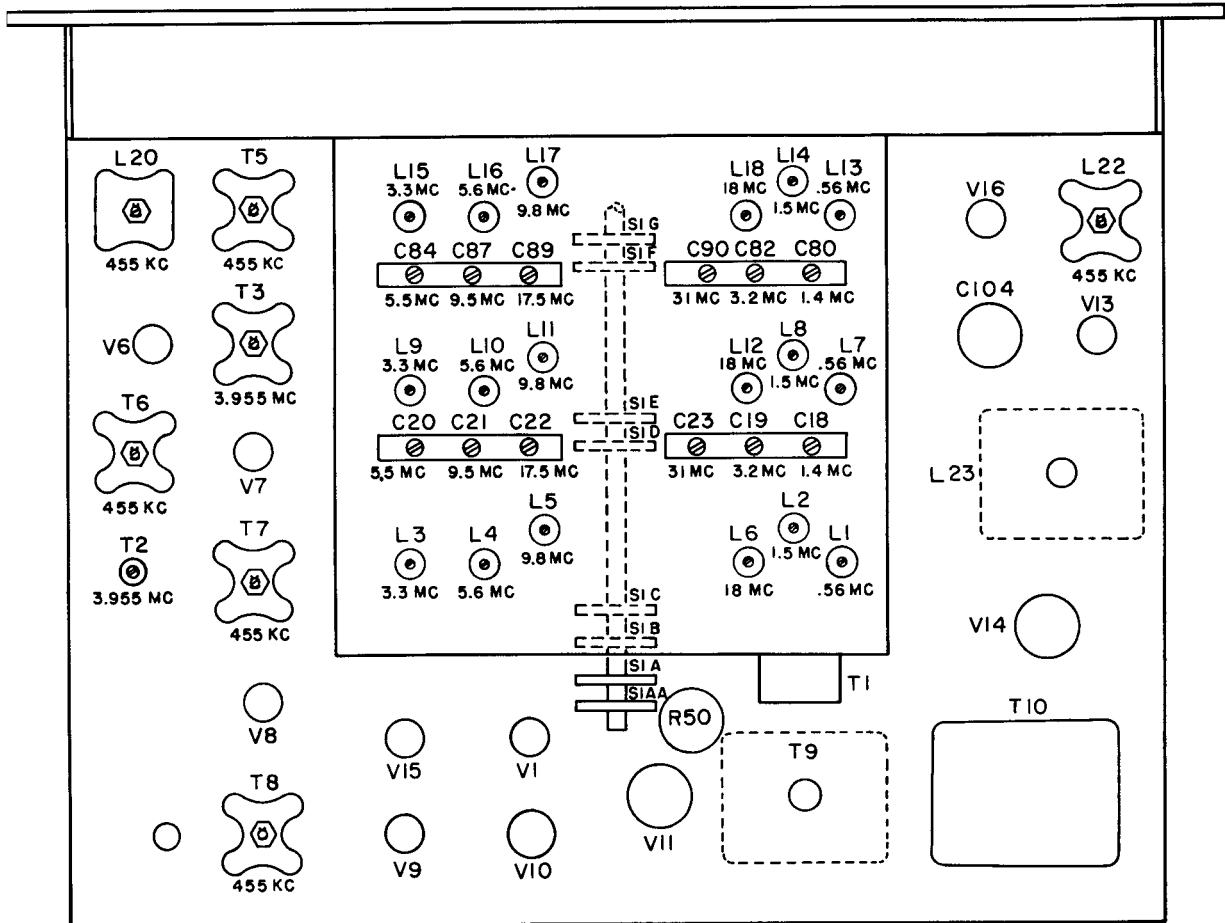

Figure 4-4. Receiver Chassis, Bottom View

of vtvm. T3 is adjusted at bottom only; T2 is adjusted at both top and bottom.

#### RF-ALIGNMENT PROCEDURES

4-20 In aligning the r-f section of the receiver, the lowest frequency band is aligned first, followed by the next higher band, and so forth. The location of each part adjusted during r-f alignment, as well as the frequency band covered by that adjustment, is shown in Figure 4-4.

4-21 The following steps describe the alignment procedures for the broadcast band. Align the other bands in a similar manner, using the data given in Table VII.

a. Set receiver controls same as for i-f alignment (paragraph 4-16). In addition, set RF SELECTIVITY control at NON XTAL position, and lock BAND SPREAD control at 100 on logging scale.

b. Connect signal generator, dummy antenna resistor, 560-ohm audio load, and a-c vtvm as shown in Figure 4-3.

c. Turn receiver MAIN TUNING dial to 0.56 mc.

d. Adjust signal generator for output of 0.56 mc, modulated 30 percent with 400 cps.

e. Adjust amplitude of signal generator output until some deflection of vtvm is noted.

f. In order, adjust coils L13, L7, and L1 for maximum deflection of vtvm.

g. Turn receiver MAIN TUNING dial to 1.4 mc, and adjust signal generator for output of 1.4 mc.

h. In order, adjust capacitors C80 and C18 and ANT. TUNE control (C10) for maximum deflection of vtvm.

#### NOTE

During alignment, signal generator output should be progressively reduced to prevent overloading receiver.

- i. Repeat steps d through h until there is no further improvement in sensitivity and frequency calibration.
- j. Set signal generator to proper image frequency (Table VII), and check that local oscillator is operating above signal frequency.

**ADJUSTMENT PROCEDURES FOR HUM BALANCE CONTROL**

4-22 To adjust HUM BALANCE control R94 (Figure 4-2) proceed as follows:

- a. Connect 560-ohm audio load across 600-ohm speaker terminals.
- b. Ground receiver to an external ground.
- c. Connect a-c vtvm across 600-ohm speaker terminals.
- d. Turn receiver on and set RF GAIN control for minimum gain.
- e. Turn AUDIO GAIN control to its maximum setting.
- f. Adjust HUM BALANCE control for minimum deflection of vtvm.

**CALIBRATION OF S METER**

4-23 To calibrate the S meter, perform the following procedures:

- a. Turn receiver on and set controls as follows:

<i>Control</i>	<i>Setting</i>
RANGE SELECTOR	5.4-9.6
RF SELECTIVITY	NON XTAL
RF GAIN	maximum (clockwise)
MANUAL-AVC	AVC
HFO (GPR-90RX only)	VAR.
MAIN TUNING	7 mc

- b. Connect signal generator and dummy antenna resistor to 75-ohm unbalanced antenna terminals as shown in Figure 4-3.
- c. Apply 7-mc, 50-microvolt signal to receiver.
- d. Tune receiver to signal and adjust ANT. TUNE control for maximum deflection of S meter.
- e. Adjust S METER ADJ control on top of receiver chassis (Figure 4-2) for S-meter reading of S-9.

**TABLE VII**  
**RF-ALIGNMENT DATA**

<i>Band</i>	<i>Sig. Gen. and Receiver Tuning-Dial Setting (mc)</i>	<i>Adjust for Maximum Output in Order Given</i>			<i>Image Frequency (mc)*</i>
		<i>Oscillator</i>	<i>Mixer</i>	<i>R-F Amplifier</i>	
1	0.56	L13	L7	L1	1.47
	1.4	C80	C18	ANT. TUNE	2.31
2	1.5	L14	L8	L2	2.41
	3.2	C82	C19	ANT. TUNE	4.11
3	3.3	L15	L9	L3	4.21
	5.5	C84	C20	ANT. TUNE	6.41
4	5.6	L16	L10	L4	13.51
	9.5	C87	C21	ANT. TUNE	17.41
5	9.8	L17	L11	L5	17.71
	17.5	C89	C22	ANT. TUNE	25.41
6	18.0	L18	L12	L6	25.91
	31.0	C90	C23	ANT. TUNE	38.91

\* Use sufficient generator output.

## SECTION 5

### THEORY OF OPERATION

#### SUBJECT AND PURPOSE OF THIS SECTION

5-1 The theory of operation of Radio Receiver Models GPR-90RX and GPR-90 is presented in this section. A general description of receiver operation using an over-all block diagram is given first. Following this, a general description of operation is given for each of the major sections of the receiver, using block diagrams where necessary. Finally, the operation of each receiver circuit is discussed in detail.

5-2 The theory of operation of both receiver models is essentially the same. The differences between the two models are pointed out where applicable.

#### HOW RADIO RECEIVER MODELS GPR-90RX AND GPR-90 WORK

5-3 The following analysis traces the path of a received signal through the various stages of the receiver (Figure 5-1). Signals received by the antenna are coupled to the antenna circuit where undesired frequencies are filtered to ground. The selected signal from the antenna circuit is amplified in the r-f circuits and applied to the conversion circuits. In the conversion circuits, the signal is heterodyned with the output of a local oscillator to produce the intermediate frequency. To eliminate image interference, which is more prevalent at higher frequencies, the receiver uses double conversion when operating in the higher frequency bands. The i-f signal is applied to the i-f circuits through a crystal filter, which provides various degrees of receiver selectivity. The degree of selectivity desired is obtained through operation of the RF SELECTIVITY switch on the receiver's front panel. This switch has six positions, although only one of them is shown in Figure 5-1. In the NON XTAL position, the crystal is shorted, while the remaining five positions provide increased selectivity by decreasing resistance in series with the crystal filter load.

5-4 The i-f circuits amplify the i-f signal and apply it to the detector and noise limiter, where the audio intelligence is detected and noise peaks are removed. In addition, an avc voltage is generated in the avc stage and fed back to the r-f and i-f circuits. When the MANUAL-AVC

switch is in the MANUAL position, the avc voltage is shorted to ground, and volume control must be set manually. The audio output from the detector and noise limiter is amplified in the audio circuits and applied to a speaker or headphones. An audio filter provides three ranges of audio selectivity: NORMAL, LOW-PASS, and 1200 ~ PEAK. These ranges are selected by means of the AUDIO SELECTOR switch on the front panel of the receiver.

5-5 During cw operation, a Hartley-type beat-frequency oscillator is employed. The bfo is placed in operation by the front panel BFO-OFF switch. With this switch in the BFO position, the output of the oscillator is injected into the i-f circuits where it combines with the i-f signal to produce an audio beat note. The pitch of the beat note may be varied by the BFO PITCH front panel control. The bfo is also used during ssb operation to supply the carrier for the side-band signal being received.

#### ANTENNA CIRCUITS AND R-F CIRCUITS

5-6 The antenna circuits (Figure 5-2) consist of a broad-band toroidal input transformer and high-pass filters, while the r-f circuits are made up of two r-f amplifiers. When the RANGE SELECTOR switch is in either position 1 or 2, the input transformer couples the signal received by the antenna directly to the second r-f amplifier. The first r-f amplifier is removed from the circuit. With the RANGE SELECTOR switch in either position 3, 4, 5, or 6, the transformer couples the received signal to high-pass filters, which reduce cross modulation interference to the receiver. The filtered signal is then amplified by the first r-f amplifier and coupled to the second r-f amplifier, whose output is applied to the conversion circuits.

5-7 The output of a crystal controlled calibration oscillator is applied to the antenna input transformer when the receiver CAL-OFF switch is in the CAL position. This supplies a check point every 100 kc throughout the tuning range of the receiver. When the switch is turned to OFF, plate voltage is removed from the calibration oscillator.

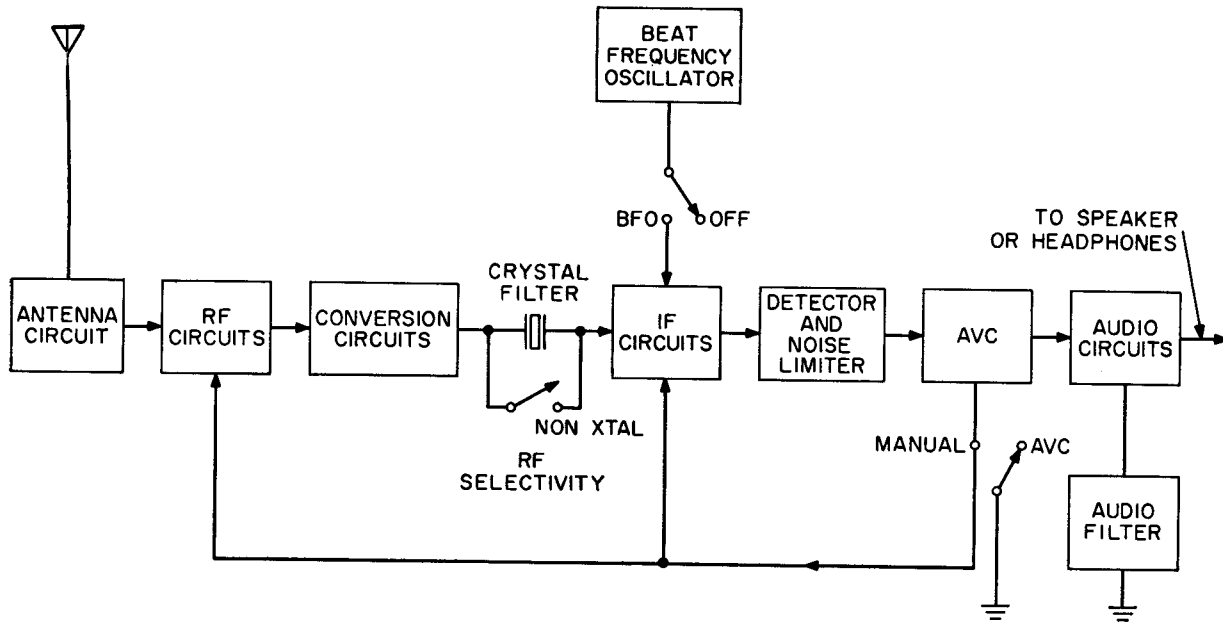

Figure 5-1. Radio Receiver Models GPR-90RX and GPR-90, Block Diagram

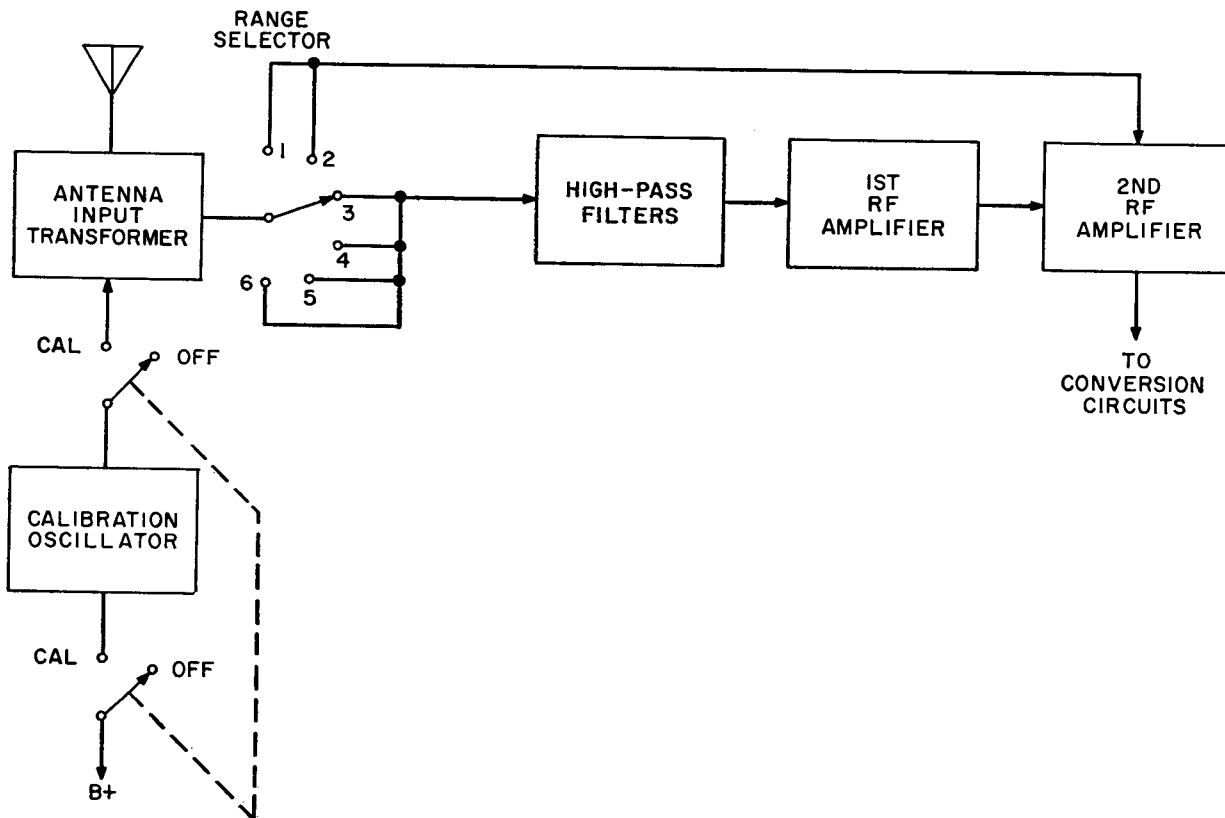

Figure 5-2. Antenna Circuits and R-F Circuits, Block Diagram

## CONVERSION CIRCUITS

5-8 The conversion circuits receive the output of the second r-f amplifier and convert it into the receiver intermediate frequency of 455 kc. Both single and double conversion are used. For double conversion, the r-f signal is first heterodyned into an if. of 3.955 mc. The second conversion produces the final if. of 455 kc.

5-9 The conversion circuits (Figure 5-3) consist of a first converter and its associated variable oscillator, a crystal controlled oscillator, a second converter and its associated oscillator (both contained in a pentagrid tube), and a buffer. The signal from the second r-f amplifier is applied to the first converter, where it is mixed with either the variable oscillator output or the crystal oscillator output. With the RANGE SELECTOR switch in position 1, 2, or 3, this mixing results in a 455-kc if. signal, which is coupled, through the RANGE SELECTOR switch, to the buffer stage. The output of the buffer is then applied to the crystal filter circuit. When the RANGE SELECTOR switch is in position 4, 5, or 6, the output of the first converter is an if. of 3.955 mc. This first if. is applied to the second converter and oscillator where the second mixing operation takes place. The resulting output is an if. of 455 kc, which is then coupled to the i-f amplifier stages through the crystal filter.

## I-F CIRCUITS

5-10 The output of the crystal filter is coupled to three i-f amplifiers. These three stages provide amplification and selectivity for the 455-kc if. before the audio signal is separated from the carrier. The output of the bfo is applied to the third i-f amplifier where it beats with the i-f signal. This produces an audible signal at the receiver output even though no modulation is present on the r-f carrier. The output of the third i-f amplifier is coupled to the detector.

## DETECTOR, LIMITER, AND AVC

5-11 The detector rectifies the incoming signal and filters its high-frequency components to ground, leaving only the audio variations. One output of the detector is applied to the avc circuit where it is converted to a negative d-c voltage proportional to the received signal. The avc voltage is then fed back to the r-f and i-f amplifiers where it automatically varies the gain of these stages. Thus, on strong signals the gain of the receiver is reduced, and on weak signals the gain is increased.

5-12 The second output of the detector is coupled to the limiter circuit. This circuit acts as a series conductor of audio voltage between the detector and first audio amplifier during periods of no noise. When noise peaks occur, the limiter

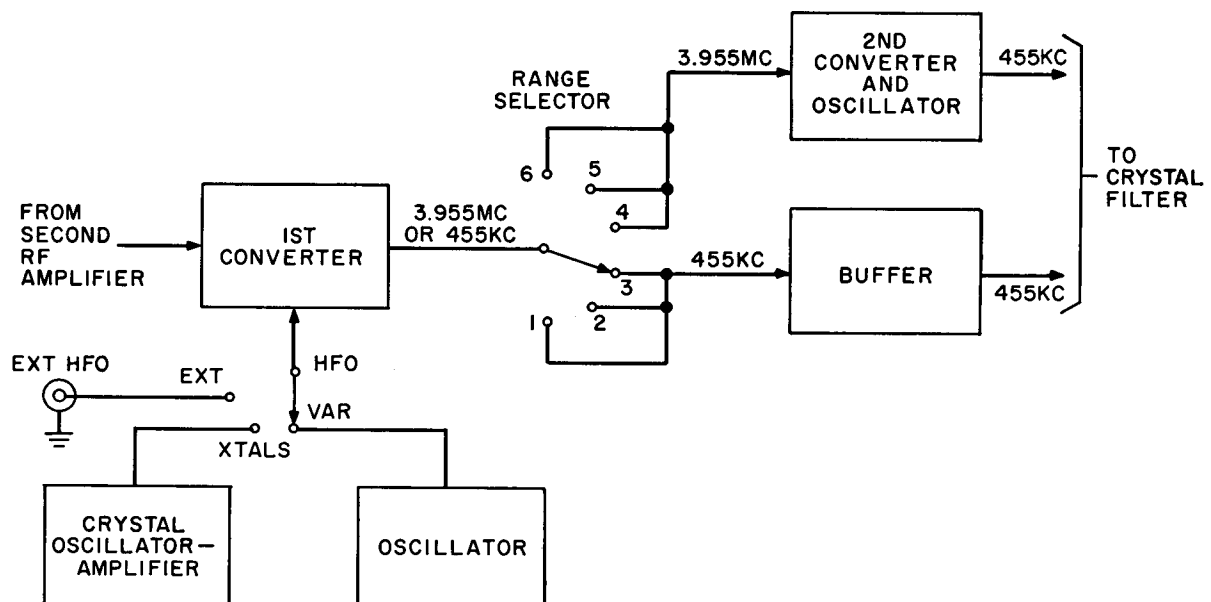

Figure 5-3. Conversion Circuits, Block Diagram

acts as an open circuit, thus preventing transient noise peaks from reaching the receiver output.

### AUDIO CIRCUITS

5-13 The audio circuits consist of a voltage amplifier and a power amplifier. The voltage amplifier amplifies the signal voltage to a level sufficient to drive the power amplifier, whose output is coupled to an external speaker or headphones. The frequency characteristics of the first audio amplifier can be altered by the AUDIO SELECTOR and AUDIO SPREAD front panel controls. This allows the receiver's audio bandwidth to be adjusted for optimum reception of various types of signals.

### RECEIVER POWER

5-14 All operating voltages for the receiver are provided by a receiver power supply. The input voltage to this supply can be either 115 or 230 volts, at 50 or 60 cps. The output voltages are 250 volts, unregulated dc, 150 volts, regulated dc, and 6.3 volts ac.

### CIRCUIT ANALYSIS OF RADIO RECEIVER MODELS GPR-90RX AND GPR-90

5-15 The following is a detailed discussion of the theory of operation of receiver models GPR-90RX and GPR-90. Figures 5-4 and 5-5 are schematic diagrams of model GPR-90RX and model GPR-90, respectively.

### ANTENNA CIRCUIT

5-16 The antenna circuit (Figure 5-6) consists basically of broadband, toroidal antenna input transformer T1 and three high-pass filter sections. The input transformer is used throughout the receiver's operating range. It is capable of matching antenna impedances of 75 or 300 ohms, balanced or unbalanced, in the frequency range of 2 to 30 mc. One end of the secondary of T1 is kept at r-f ground potential by capacitor C1.

5-17 The high-pass filter sections reduce cross modulation at the receiver input. When the receiver is operating in bands 1 and 2 these filters are not used, and the input signal is coupled directly from transformer T1 to antenna coil L1 or L2 and then to the control grid of the second r-f amplifier. In band 3, the first high-pass filter section, made up of capacitors C117 and C118 and inductors L28, L29, and L30, is connected in the cathode circuit of the first r-f amplifier. The input signal is applied to the first r-f amplifier through this filter, which attenuates all frequencies below 1.8 mc.

5-18 In band 4, the second high-pass filter section, made up of capacitors C139, C140, and C141, and inductors L32, L33, and L34, is added in series with the first. This second filter section attenuates all frequencies below 4.5 mc. In bands 5 and 6, the third filter section, made up of capacitors C142 and C143 and inductor L35, is inserted in series with the first two. It provides additional attenuation of frequencies below 4.5 mc.

### R-F AMPLIFIER CIRCUITS

5-19 *First R-F Amplifier.*—The first r-f amplifier, V1, employs a type 6AB4 triode. This amplifier is not used in bands 1 and 2. The r-f input is applied to the cathode, pin 7. Cathode bias is provided by resistor R1 and variable resistor R81, which is adjusted by the RF GAIN control. The grid is connected to the avc line through a decoupling network consisting of resistor R2 and capacitor C2. This assures a reasonably smooth d-c voltage for use as avc bias. The amplified voltage developed in the plate circuit of V1 is coupled through the antenna coil for the band in use (L3, L4, L5, or L6) to the signal grid of second r-f amplifier V2.

5-20 *Second R-F Amplifier.*—The second r-f amplifier, V2, uses a type 6CB6 pentode in a conventional voltage amplifier circuit. It is used throughout the entire tuning range of the receiver. In bands 1 and 2, the received signal is coupled from the secondary of input transformer T1, through capacitor C110, to antenna coil L1 or L2. The antenna coil in use, together with one section of MAIN TUNING capacitor C9, form a parallel resonant circuit. The voltage developed across this circuit is applied to the input, pin 1, of V2. During operation in all other bands, the input to this stage is received from the first r-f amplifier.

5-21 Cathode bias is provided by fixed resistor R10 and RF GAIN resistor R81. A small amount of degeneration is introduced because cathode resistor R9 is unbypassed. AVC bias voltage is applied to the grid of V2 through a decoupling network consisting of resistor R7 and capacitor C7. Variable capacitor C10, also connected in the grid circuit, provides fine tuning of the input frequency under varying load conditions. It is varied by the front panel ANT. TUNE control. The output of the second r-f amplifier is taken from pin 5 and applied to one of five r-f coils (L7 through L12), depending on the band in use. A small trimmer capacitor is connected across each coil. The selected coil, together with a portion of MAIN TUNING

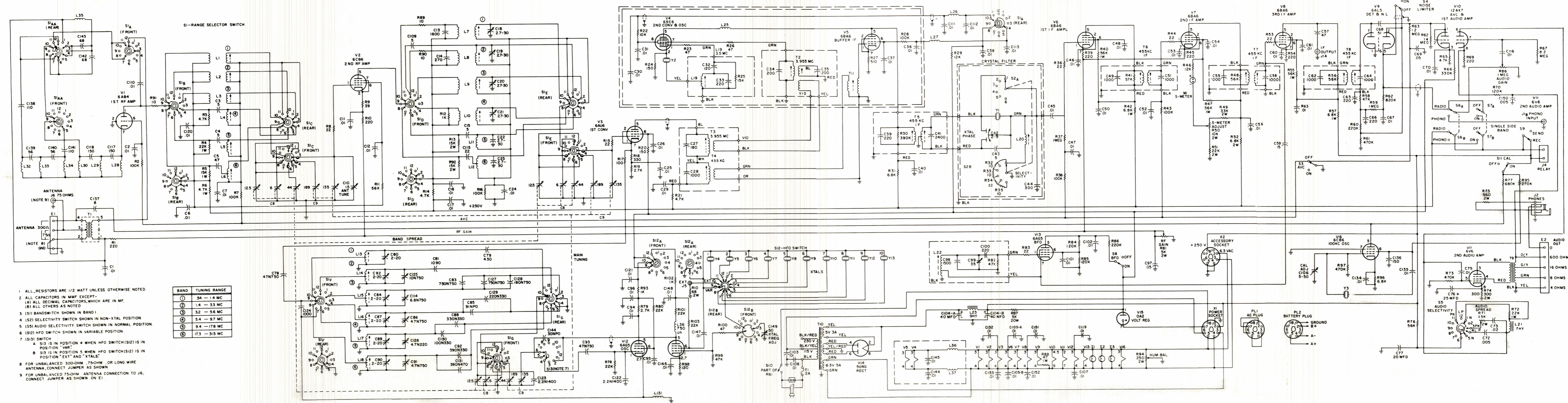

Figure 5-4. Radio Receiver Model GPR-90RX, Schematic Diagram

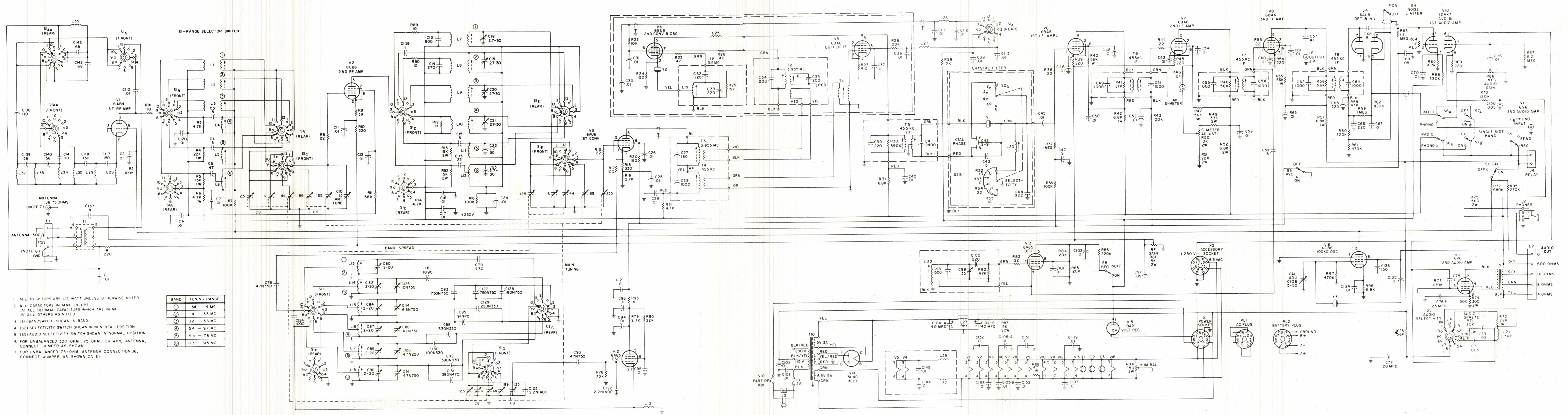
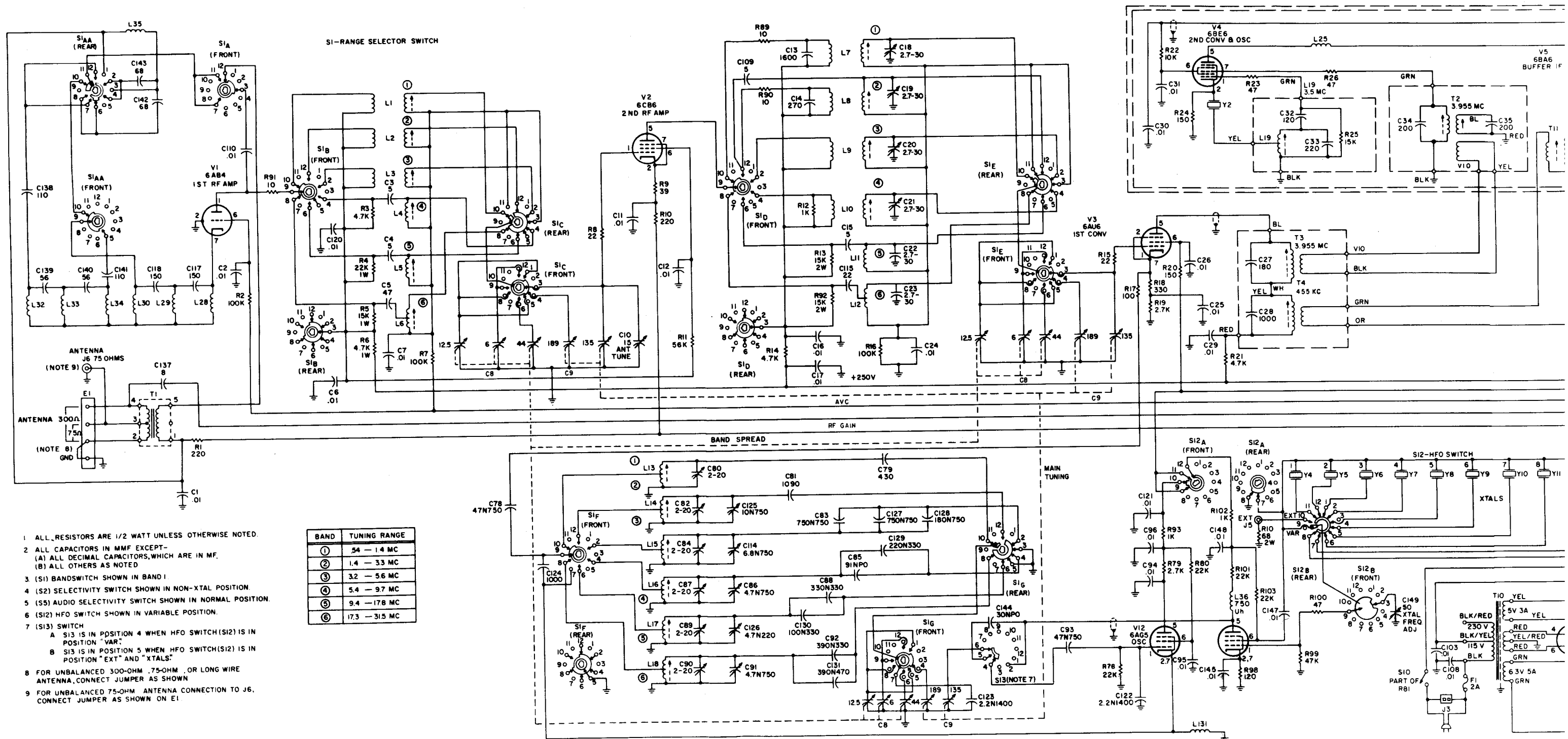

Figure 5-5. Radio Receiver Model GPR-90, Schematic Diagram



- 1 ALL RESISTORS ARE 1/2 WATT UNLESS OTHERWISE NOTED.
- 2 ALL CAPACITORS IN MMF EXCEPT-  
(A) ALL DECIMAL CAPACITORS, WHICH ARE IN MF.  
(B) ALL OTHERS AS NOTED
- 3 (S1) BANDSWITCH SHOWN IN BAND 1
- 4 (S2) SELECTIVITY SWITCH SHOWN IN NON-XTAL POSITION.
- 5 (S5) AUDIO SELECTIVITY SWITCH SHOWN IN NORMAL POSITION.
- 6 (S12) HFO SWITCH SHOWN IN VARIABLE POSITION.
- 7 (S13) SWITCH  
A S13 IS IN POSITION 4 WHEN HFO SWITCH (S12) IS IN POSITION "VAR."  
B S13 IS IN POSITION 5 WHEN HFO SWITCH (S12) IS IN POSITION "EXT" AND "XTALS"
- 8 FOR UNBALANCED 300-OHM .75-OHM OR LONG WIRE ANTENNA, CONNECT JUMPER AS SHOWN
- 9 FOR UNBALANCED 75-OHM ANTENNA CONNECTION TO J6, CONNECT JUMPER AS SHOWN ON E1

BAND	TUNING RANGE
①	54 - 1.4 MC
②	1.4 - 3.3 MC
③	3.2 - 5.6 MC
④	5.4 - 9.7 MC
⑤	9.4 - 17.8 MC
⑥	17.3 - 31.5 MC

Figure 2 - Radio Receiver



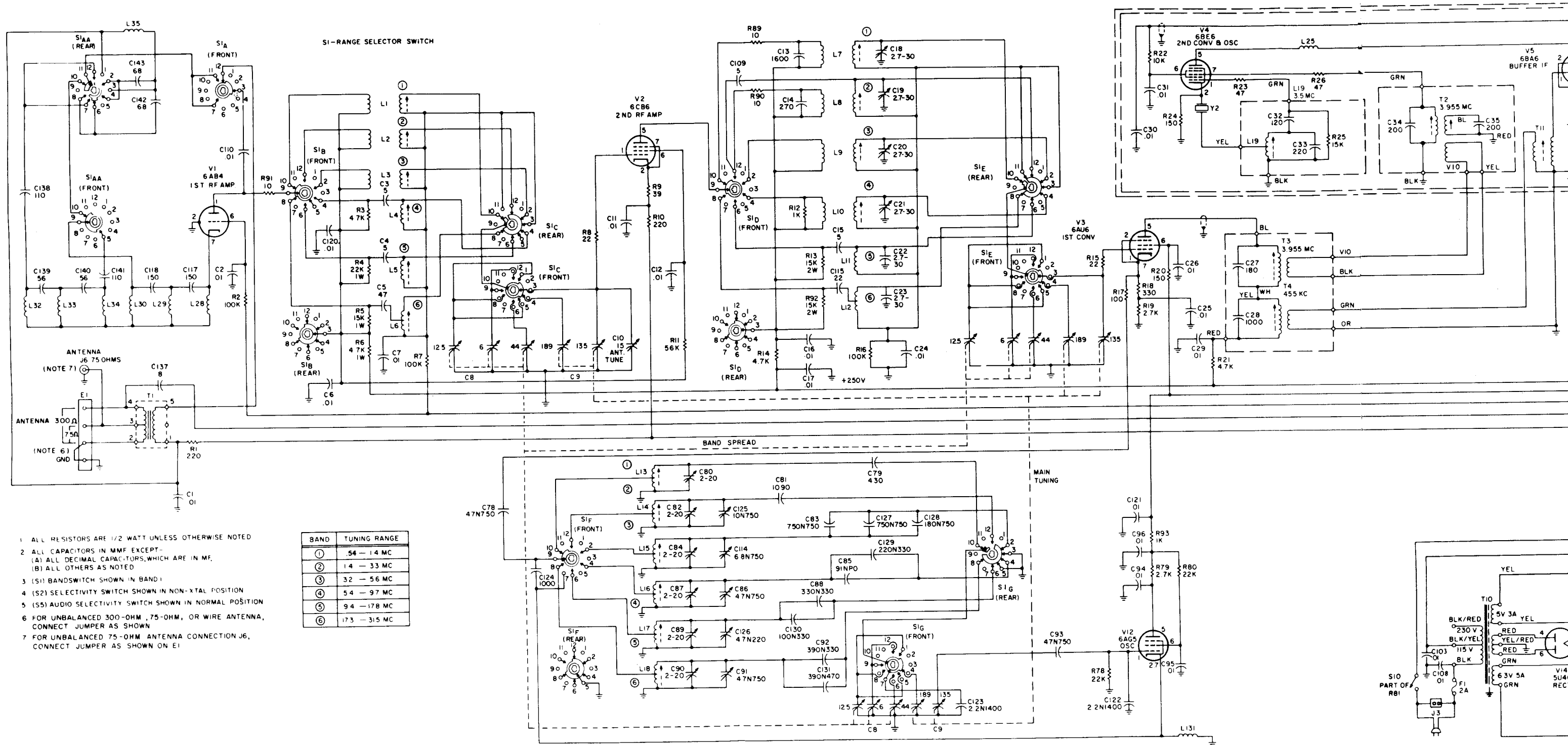
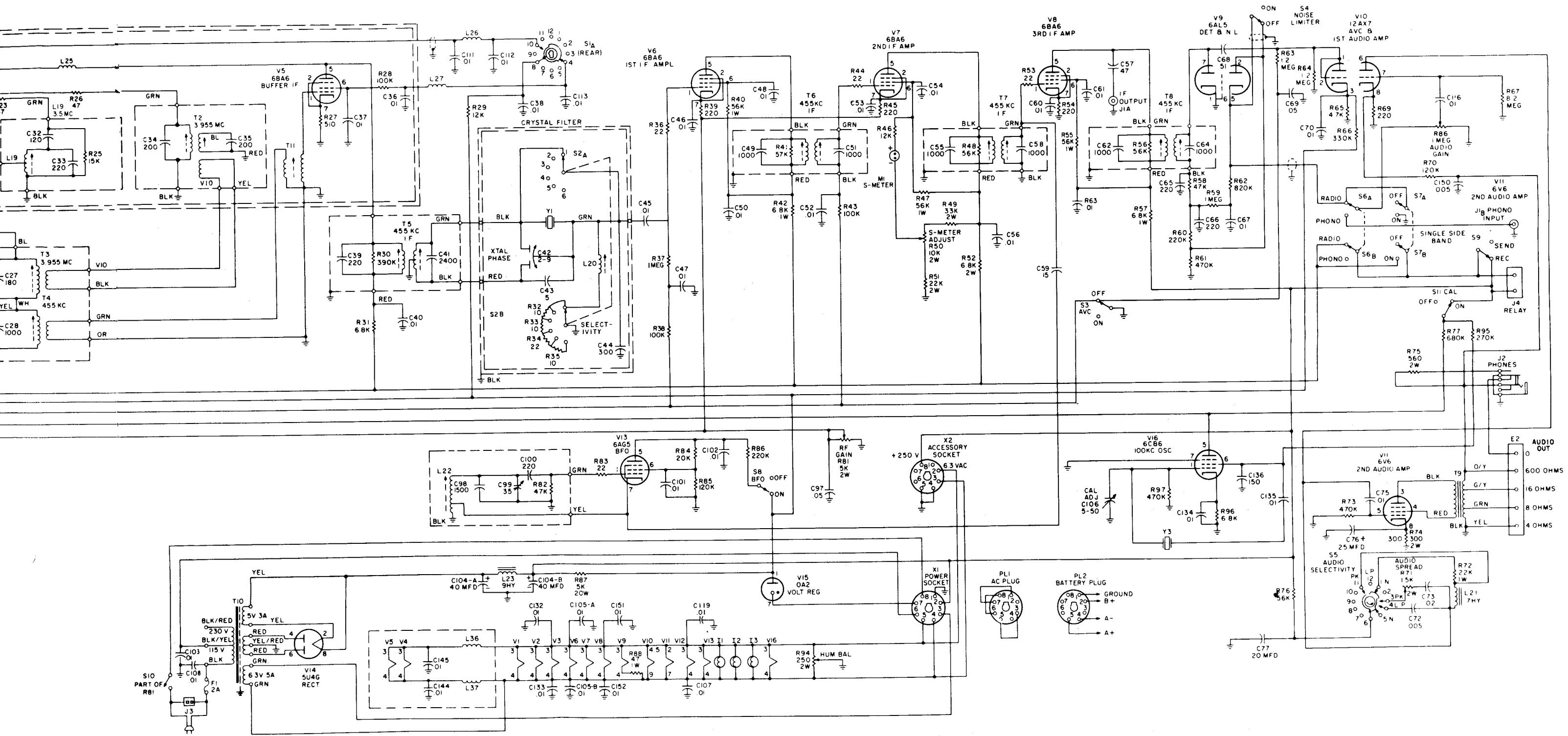

Figure 5-5. Radio Receiver Model GPR-90, Schematic Diagram



5-5. Radio Receiver Model GPR-90, Schematic Diagram

capacitor C9, make up a parallel resonant circuit. The voltage developed across this circuit is applied to the control grid of the first converter.

**LOCAL OSCILLATOR**

5-22 The local oscillator employs a 6AG5 pentode, V12, connected in a conventional Hartley oscillator circuit. The oscillator section of V12 consists of the cathode, control grid, and screen grid. Bias for this stage is provided by resistor R78 and capacitor C122. At r-f frequencies, the screen grid is effectively at ground potential. The output of the oscillator is taken from the cathode and coupled through capacitor C78 and resistor R17 to pins 1 and 7 on first converter V3. In V3, the output of the oscillator is heterodyned with the received signal to produce an intermediate frequency of either 455 kc or 3.955 mc, depend-

ing upon which receiver band is being used. With RANGE SELECTOR switch S1 in band 1, 2, or 3 (0.54 to 5.4 mc), the output of the local oscillator is mixed with the received signal to produce a 455-kc i-f signal. A 3.955-mc i-f signal is produced with the receiver operating in band 4, 5, or 6 (5.4 to 31.5 mc).

5-23 A separate tuned circuit is used for each band of receiver operation. Tuning within a particular band is accomplished by varying the MAIN TUNING capacitor, C9, and then BAND SPREAD capacitor C8. The trimmer capacitor and inductor of each tank circuit are also variable and are used for alignment purposes only. Temperature-compensating capacitors are employed as padders in the oscillator tank circuits used during operation in bands 3, 4, 5, and 6.

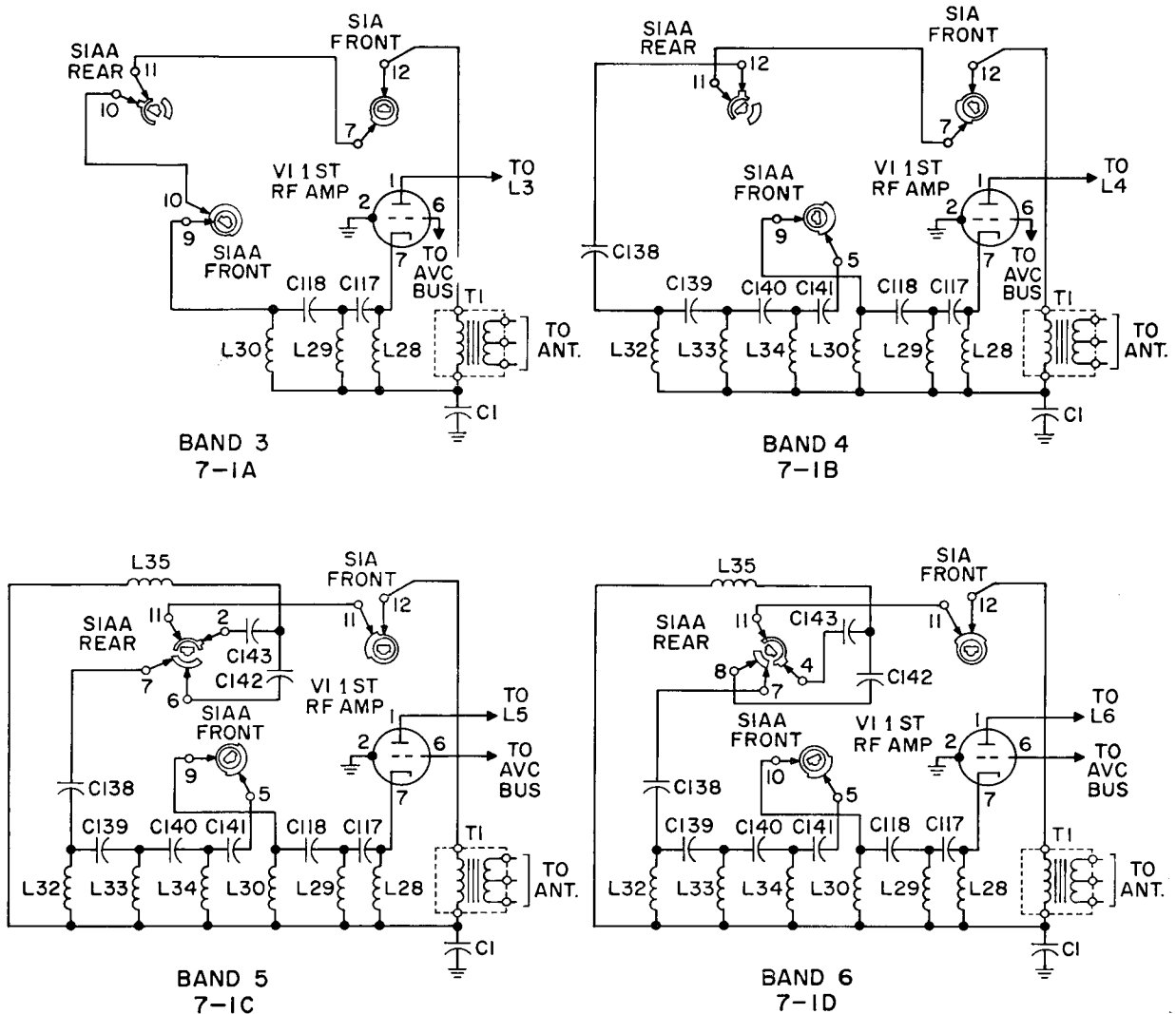

Figure 5-6. Antenna Circuit, Simplified Schematic Diagram

### CRYSTAL OSCILLATOR-AMPLIFIER (GPR-90RX only)

5-24 The crystal oscillator-amplifier, V17, is used in receiver model GPR-90RX only. It employs a 6AG5 pentode in a modified Pierce oscillator circuit. The screen grid acts as the plate of a triode oscillator composed of the screen grid, the control grid, and the cathode. Oscillator output is taken from a tuned circuit in the actual plate circuit of the tube, thus providing a degree of amplification as well as minimizing the effects of load variation upon oscillator frequency. The crystal frequency may be varied slightly by use of the XTAL ADJ. control (C149), located on the front panel.

5-25 Output of the crystal oscillator stage is coupled from the plate of V17 to the cathode of the first converter, V3. The plate of V17 is connected to the output tank circuits through rotary switch S13. S13 is located on the rear of HFO switch S12. With the HFO switch in XTAL position, S13 disconnects the grid of oscillator V12 from the tank circuit and connects the output of crystal oscillator V17 in its place. When the HFO switch is in the VAR. position the reverse condition exists, with the grid circuit of V12 now connected to the tank circuits through S13, and the plate connection of V17 open.

5-26 When the HFO switch is placed in the EXT. position, the grid circuit of V12 is opened as explained above. Also, the crystal being used is removed from the screen and grid circuits of V17, and a signal from an external oscillator is applied, through EXT jack J5, to the grid of V17. V17 now serves as an amplifier to raise the external oscillator signal to the level required for proper heterodyning action in the converter tube, V3.

### CONVERSION CIRCUITS

5-27 *First Converter.*—The first converter, V3, uses a 6AU6 pentode connected in a conventional mixer circuit. The output signal from the second r-f amplifier is coupled to the control grid of V3, and the output signal from the local oscillator, V12, is coupled to the cathode of V3. These two signals are then heterodyned in the converter stage to produce an intermediate frequency of either 455 kc or 3.955 mc, depending upon the frequency band in use.

5-28 With the receiver operating in band 1, 2, or 3, the output of the first converter is a 455-kc signal. This signal is coupled through transformers T4 and T11 to pin 1 on V5. With the receiver operating in band 4, 5, or 6, the first

converter produces a 3.955-mc signal, which is coupled through transformers T3 and T2 to pin 7 on the second converter and oscillator, V4.

5-29 *Second Converter and Oscillator.*—The second converter and oscillator, V4, employs a 6BE6 pentagrid tube connected in a conventional pentagrid converter circuit. This stage is used only when the receiver is operating in band 4, 5, or 6. The 3.955-mc output signal of the first converter is coupled to pin 7 on V4 and is heterodyned with the 3.5-mc signal developed in the oscillator section of V4. The 455-kc i-f signal appearing on pin 5 is then coupled through the first i-f transformer, T5, to either the input of the crystal filter or the first i-f stage. With RF SELECTIVITY switch S2 in the NON XTAL position, the 455-kc i-f signal is coupled through capacitor C45 to the grid of the first i-f amplifier. With the RF SELECTIVITY switch in any of the five remaining positions, the 455-kc i-f signal is applied to the crystal filter circuit.

5-30 The oscillator section of V4 consists of the cathode, pin 2, the oscillator grid, pin 1, and the inner and outer screen grids, pin 6. The inner and outer screen grids are connected together internally and serve as a composite anode for the oscillator triode. The circuit operates as a crystal controlled Hartley oscillator. Oscillator anode to oscillator grid feedback is developed across tapped inductor L19. Crystal Y2, in the feedback circuit, ensures oscillator stability. Bias for the oscillator circuit is developed across resistor R25 and capacitor C32.

### BUFFER I-F AMPLIFIER

5-31 The buffer i-f amplifier uses a 6BA6 pentode, V5, and functions as both an i-f amplifier and a buffer. It provides isolation between local oscillator V12 and the succeeding amplifiers in the receiver. This stage is used only when the receiver is operating in band 1, 2, or 3. During operation in band -4, -5, or -6 this stage is disabled by removing its screen grid voltage.

5-32 The input to the buffer i-f. is coupled through transformer T11 and applied to the control grid of V5. By employing link coupling between the first converter, V3, and the buffer i-f., interaction between the two stages is reduced considerably. The amplified output of this stage is coupled through the first i-f transformer, T5, to either the crystal filter or the grid of the first i-f amplifier, as described in paragraph 5-29.

### CRYSTAL FILTER

5-33 The crystal filter provides additional receiver selectivity and also eliminates heterodyn-

ing between the desired signal and an interfering signal. The crystal filter consists essentially of 455-kc crystal Y1, RF SELECTIVITY control S2, XTAL PHASE control C42, and a parallel resonant tank circuit consisting of inductor L20 and capacitor C44. The RF SELECTIVITY and XTAL PHASE controls are located on the front panel of the receiver.

5-34 With the RF SELECTIVITY control in the NON XTAL position, the crystal is short circuited, and the output of second converter and oscillator V4 or buffer if. V5 is coupled to the grid of the first i-f amplifier. The remaining five positions of this control provide increased selectivity from 2 to 0.25 kc (Figure 5-7). The output of the crystal filter is developed across the

parallel resonant circuit consisting of inductor L20 and capacitor C44. Increased selectivity is gained by decreasing the resistance in series with inductor L20, thus increasing the coil's Q and narrowing its band pass.

5-35 The ability of the crystal filter to eliminate heterodyning between the desired signal and an interfering signal is controlled by the XTAL PHASE control. With the RF SELECTIVITY control in the 2.0KC position, the XTAL PHASE control should be adjusted for maximum attenuation of the interfering signal.

#### I-F AMPLIFIERS

5-36 The receiver contains three i-f amplifier stages. Each stage employs a 6BA6 pentode (V6,

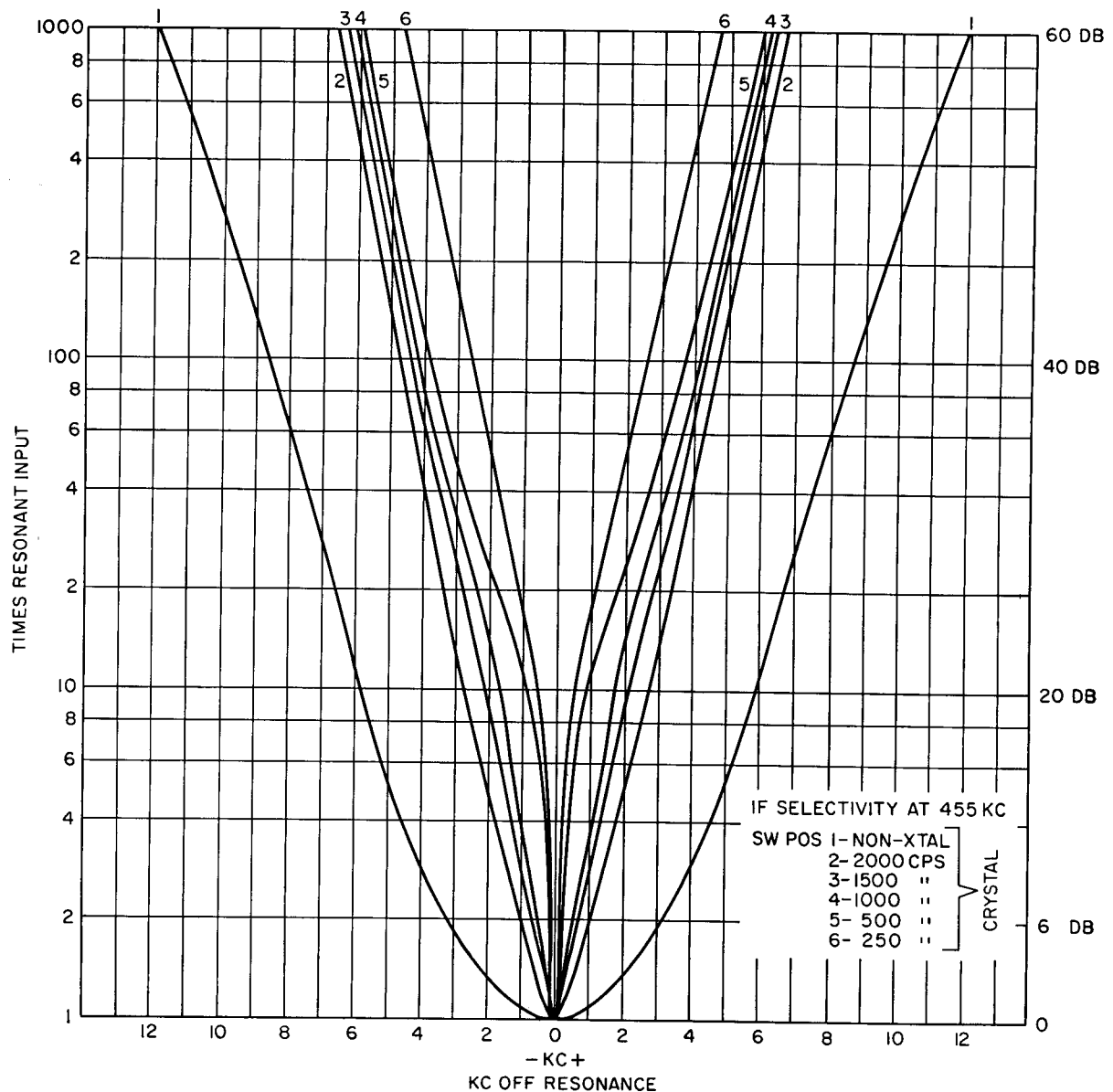

Figure 5-7. IF-Selectivity Curves

V7, and V8) in a conventional transformer coupled i-f amplifier circuit. The three stages are tuned to the 455-kc i-f frequency.

5-37 The input signal to the first i-f amplifier, V6, is applied to pin 1. The amplified output signal appears on pin 5 and is coupled through i-f transformer T6 to the control grid of the second i-f amplifier. Bias for V6 is developed across cathode resistor R39 and RF GAIN control R81. AVC voltage is applied to the grid of V6 through resistor R37. Resistor R38 and capacitor C46 make up a decoupling network for the avc line.

5-38 The input signal to the second i-f amplifier V7 is developed across the secondary of i-f transformer T6 and applied to pin 1. The amplified output signal appearing at the plate is coupled through i-f transformer T7 to the control grid of the third i-f amplifier. Cathode resistor R45 and RF GAIN control R81 provide cathode bias for V7. AVC voltage is applied to the grid of V7 through the secondary of i-f transformer T6. Resistor R43 and capacitor C52 provide decoupling for the avc line. An S meter is in series with the screen grid of V7 to provide a visual indication of the strength of the received signal. S-meter calibration is correct only when avc is used. The meter is essentially a milliammeter calibrated in units from 1 to 9. An S-9 indication on the meter corresponds to a signal strength of 50 millivolts.

5-39 The input signal to the third i-f amplifier V8 is developed across the secondary of i-f transformer T7 and applied to the control grid. When the beat frequency oscillator is used, its output is also applied to the control grid of V8. The amplified output signal appearing on pin 5 is coupled through i-f transformer T8 to pin 7 of the detector. Bias for V8 is provided by cathode resistor R54.

#### BEAT FREQUENCY OSCILLATOR

5-40 The bfo, V13, employs a 6AG5 in a conventional Hartley oscillator circuit. The bfo is used to obtain an audible beat note when receiving cw signals, or for carrier reinsertion during ssb operation. It may also be used to locate the carrier of a weak phone signal. After the phone carrier has been located, however, the bfo must be turned off.

5-41 The oscillator section of V13 consists of the cathode, control grid, and screen grid. Grid leak bias is developed across grid resistor R82. Capacitor C101 places the screen grid essentially at ground potential for r-f signals, and the output

of the oscillator is taken from the cathode. The output is then coupled through capacitor C59 to the grid of the third i-f amplifier.

5-42 The bfo is put in use by placing front-panel BFO-OFF switch S8 in the BFO position. When switch S8 is placed in the OFF position, plate and screen grid voltages are removed from V13, and the bfo is disabled. The pitch of the beat note may be varied by operating front-panel BFO PITCH control C99.

#### DETECTOR AND NOISE LIMITER

5-43 The detector and noise limiter each use one-half of a type 6AL5 dual diode V9. They are described separately in the following paragraphs.

5-44 *Detector.*—The output of the third i-f amplifier is coupled through i-f transformer T8 and applied across the diode detector. Since the cathode is grounded, a complete path for current flow exists and the stage conducts on all positive half-cycles of the input signal. The rectified current flows through the secondary of T8 and through load resistors R58, R60, and R61 to ground, and returns to the cathode. Capacitors C65 and C66 are r-f filters that bypass to ground the r-f component contained in the rectified i-f signal. The resulting audio voltage that appears across resistors R60 and R61 is applied to the noise limiter. If limiting is not used, the voltage present at the junction of R60 and R61 is coupled to the first audio amplifier. A second output is taken from the plate of the detector stage and coupled through capacitor C68 to the avc stage.

5-45 *Noise Limiter.*—A conventional series-type noise limiter is employed to prevent spurious noise peaks from reaching the receiver output. When limiting is used, switch S4 is in the LIMITER position, thus removing the short between plate and cathode of the limiter stage.

5-46 The negative signal voltage produced by the detector is developed across capacitor C67. The rate of change of this signal voltage is limited by the long RC time constant of capacitor C67 and resistor R59. This slowly changing voltage is applied to the cathode of the noise limiter through resistor R62. Plate voltage for the limiter is derived from the voltage divider action of resistors R60 and R61. This results in the cathode being negative with respect to the plate and causes current to flow in the limiter. The current flow varies in proportion to the audio output of the detector, and as a result, the audio signal is coupled to the cathode of the limiter. Capacitor C71 then couples the audio signal to the grid circuit of the first audio amplifier.

5-47 The noise limiter conducts as long as the cathode remains negative with respect to the plate. When a large amplitude noise pulse is received, the plate is driven negative more rapidly than the cathode, due to the long time constant of the components in the cathode circuit. Therefore, with the plate instantaneously more negative than the cathode, the limiter ceases to conduct and the input to the first audio amplifier is cut off. With switch S4 in the OFF position, the signal is passed around the noise limiter.

#### AVC AND FIRST AUDIO AMPLIFIER

5-48 The avc stage and first audio amplifier each use one-half of a type 12AX7 dual triode, V10. The avc portion of V10 has its grid and plate connected together, and thus acts as a diode. The audio amplifier portion functions as a conventional class A voltage amplifier.

5-49 *AVC Stage.*—The avc diode, in conjunction with resistors R63 and R64, and capacitors C68 and C69, develops a delayed avc bias voltage that is fed back to the r-f and i-f stages. This avc voltage then prevents the receiver from blocking on strong signals and keeps the receiver gain constant over a wide variation of input signal strength.

5-50 The i-f signal developed across the secondary of transformer T8 is coupled through capacitor C68 to the plate of the avc diode. Due to the RC time constant of C68 and R64, a slight negative voltage is maintained on the plate of the avc diode under normal signal conditions. The cathode is kept positive by a small voltage drop across resistor R65. Thus, with the plate negative with respect to the cathode, the tube is cut off. When the signal coupled to the plate exceeds a certain level, the plate becomes positive with respect to the cathode and the tube conducts. The resulting negative voltage on the avc line is filtered by capacitor C69 and resistor R63. The delaying feature of the avc circuit prevents the attenuation of weak input signals to the receiver.

5-51 *First Audio Amplifier.*—The audio signal on the cathode of the noise limiter is coupled through capacitor C71 to the grid circuit of the first audio amplifier and developed across variable resistor R68. R68 adjusts the level of the input to this stage. It is varied by the front panel AUDIO GAIN control. The voltage tapped off R68 is applied to the grid of the stage by capacitor C116 and resistor R67. Bias for the tube is developed across unbypassed cathode resistor R69. The amplified voltage at the plate of the first audio stage is coupled through capacitor

C75 and applied to the control grid of the second audio amplifier by resistor R73.

5-52 The bandwidth of the audio signal passed by the first audio amplifier can be varied (Figure 5-8) by AUDIO SELECTOR switch S5. With S5 in the NORMAL position, all audio frequencies are amplified uniformly. With the switch in the LOW-PASS position, capacitor C72 is connected in the plate circuit of the stage and provides attenuation of the higher audio frequencies. Minimum bandwidth, and therefore maximum selectivity, is provided when S5 is in the 1200 ~ PEAK position. In this position, a tank circuit, made up of capacitor C73 and inductor L21, is connected into the plate circuit. The tank rejects all but a narrow band of frequencies. Therefore, only this narrow band is amplified in the plate circuit of the stage. Variable resistor R71 permits fine tuning of the bandwidth. It is adjusted by the front panel AUDIO SPREAD control.

#### SECOND AUDIO AMPLIFIER

5-53 The second audio amplifier stage employs a 6V6 beam power pentode, V11, in a standard audio power amplifier circuit. The input to this stage is developed across grid resistor R73 and applied to pin 5 of V11. Bias is developed across cathode resistor R74. The amplified output signal appearing on pin 3 is coupled through audio output transformer T9 to terminal strip E2. The terminals on E2 are connected to the 4-, 8-, 16-, and 600-ohm taps on the secondary winding of the audio output transformer.

#### CALIBRATION OSCILLATOR

5-54 The calibration oscillator uses a 6CB6 pentode, V16, connected in an electron coupled Pierce oscillator circuit. The oscillator generates a stable 100-kc signal, which is beat with a signal from station WWV for calibration purposes.

5-55 The cathode, control grid, and screen grid of V16 form the oscillator circuit. The screen grid serves as the plate circuit for the oscillator. Screen grid to control grid feedback is provided through capacitor C135 and crystal Y3. Grid leak bias is developed across resistor R97. The frequency of the calibration oscillator may be varied by adjusting CAL. ADJ. capacitor C106, located on the top of the receiver chassis. The output of the oscillator is coupled through the electron stream to the plate of V16. From the plate, it is coupled through capacitor C137 to the primary of antenna input transformer T1.

5-56 The calibration oscillator is energized by placing CAL-OFF switch S11, located on the

front panel of the receiver, in the CAL position. This applies plate and screen grid voltage to the oscillator. With the CAL-OFF switch in the OFF position, plate and screen grid voltages are removed and the oscillator is disabled.

**POWER SUPPLY**

5-57 The receiver power supply is a conventional full-wave rectifier circuit employing a 5U4-G rectifier, V14, and a capacitor input filter. The supply is operated from either a 115- or 230-volt, 50- or 60-cycle power source. The power supply furnishes +150 volts dc, regulated, +250 volts dc, unregulated, and 6.3 volts ac. The regulated +150-volt d-c output is applied to the plates and screen grids of the receiver oscillator circuits; to the screen grids of the first converter and the buffer is.; and to the cathode of the avc stage. The unregulated +250-volt d-c output of the power supply furnishes operating voltages for the other receiver circuits. A separate winding on transformer T10 provides 6.3-volts a-c filament voltage to each stage of the receiver.

5-58 Resistor R87 and a type OA2 voltage regulator, V15, form a voltage divider network at the output of the power supply filter circuit. The unregulated +250-volt d-c output is taken from the junction of resistor R87 and filter choke L23. The regulated +150-volt d-c output is taken from the junction of resistor R87 and voltage regulator V15.

5-59 Off-on control of receiver power is provided by switch S10, which is part of the RF GAIN control and is in series with the power source and the primary winding of transformer T10. Fuse F1, in series with the primary winding of transformer T10, protects the power supply against overload. To minimize the 60-cycle hum in the output of the receiver, HUM BALANCE resistor R94 has been placed across the 6.3-volt a-c filament winding of transformer T10. This resistor sets the ground reference level so that the negative and positive half cycles of the filament voltage are balanced to ground. This minimizes heater-to-cathode leakage, which causes 60-cycle hum in the output of the receiver.

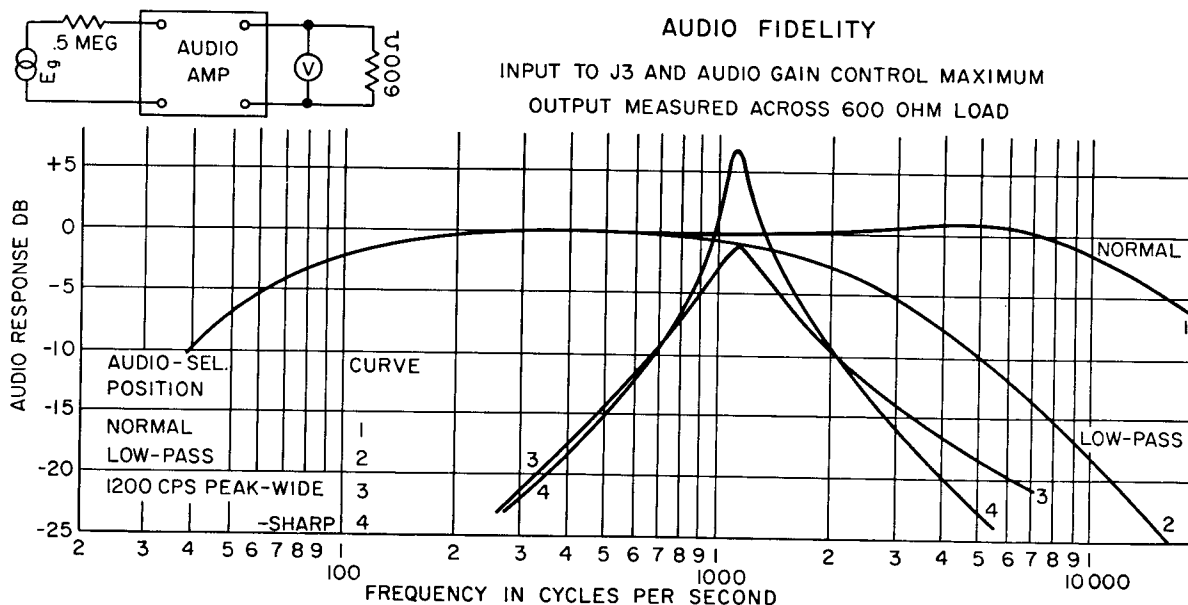

**Figure 5-8. Audio Response Curves**

## II. PARTS BREAKDOWN

### SECTION 6—EXPLANATION OF THE PARTS BREAKDOWN

#### GENERAL

6-1 This Parts Breakdown lists and describes electrical and mechanical component parts of the various items comprising the GPR-90RX and GPR-90 Radio Receivers.

6-2 The information presented in this Parts Breakdown complements the data found in Division I of this handbook.

#### ARRANGEMENT OF PARTS BREAKDOWN

6-3 Division II of this publication consists of Explanation of the Parts Breakdown (Section 6), Main Assembly Parts List (Section 7), Numerical Index (Section 8), and Reference Designation Index (Section 9).

6-4 Section 6, Explanation of the Parts Breakdown, defines the scope of Division II and explains its use. Section 6 also includes a listing of vendors' code numbers keyed to the names and addresses of manufacturers who have supplied parts for this equipment.

6-5 Section 7, Main Assembly Parts List, breaks down, in disassembly order, all of the major assemblies, subassemblies, and detail parts of this equipment.

6-6 Section 8, Numerical Index, lists each different part number contained in this breakdown, cross-referenced to the figure and index numbers where it appears within the Main Assembly Parts List.

6-7 Section 9, Reference Designation Index, lists each electrical and electronic part which has been assigned a reference designation cross-referenced to the page number on which it appears in the Main Assembly Parts List.

#### MAIN ASSEMBLY PARTS LIST.

6-8 The Main Assembly Parts List (Section 7) provides a listing in disassembly order of all major assemblies, subassemblies, and detail parts contained in the GPR-90RX and GPR-90 Radio Receivers. A system of indentation is used throughout the parts list to show the relationship of the detail parts to the subassemblies and relationships of the subassemblies to the main assemblies. The parts list is presented in tabular form and contains the columnar information described in the following paragraphs.

#### PART NUMBER.

6-9 The part numbers listed in this column are those of the Western Electric Company unless otherwise identified in the description column as government

standard items (AN, MS, JAN, or MIL) or vendors' items.

6-10 This column lists the name and descriptive information for all assemblies, subassemblies, and detail parts. Each assembly listed is immediately followed by its subassemblies and their detail parts, properly indented to show relationships. The numerals 1 through 7 at the head of this column show the relationship between assemblies, subassemblies, and detail parts. For example: an item listed under indentation 3 is a component of the assembly or subassembly under indentation 2 above it.

6-11 Abbreviations are in accordance with MIL-STD-12A.

6-12 A part supplied by a vendor is listed by the vendors' part number. The vendor is identified by code numbers following the description. The Vendors' Codes list appears at the end of this section.

6-13 Parts which attach other parts or assemblies are preceded by the statement "Attaching Parts." The symbol (---\*---) indicates the end of attaching parts.

#### UNITS PER ASSEMBLY.

6-14 The quantity listed in this column is the total quantity of the part required in its immediate assembly.

#### USABLE ON CODE.

6-15 When a single breakdown of two or more similar assemblies is made, an alphabetical code of capital letters is used in the Usable On Code column to indicate on which of the similar assemblies the parts are used. The code letter "A" indicates parts used on the GPR-90 only, and the code letter "B" indicates parts used on the GPR-90RX only. When the Usable On Code column is blank, the part is used on all assemblies.

#### NUMERICAL INDEX.

6-16 In this index (Section 8), the part numbers are arranged in alpha-numerical sequence as follows:

1. The part number arrangement starts on the left-hand column and continues from left to right, one column at a time, until part number numerical arrangement is determined.

2. The order of precedence for first-position arrangement is as follows:

Letters A through Z  
Numerals 0 through 9

3. The order of precedence for second- and succeeding-position arrangements is as follows:

- Space (blank column)
- Diagonal (/)
- Point (.)
- Dash (-)
- Letters A through Z
- Numerals 0 through 9

4. Alphabetical O's are considered as numerical zeros.

**CLASS CODE OR STOCK NUMBERS.**

6-17 For Federal Stock Numbers not given in this publication, reference should be made to the S-00-1-1 USAF Master Cross-Reference Index.

**SOURCE CODING.**

6-18 Source coding as applicable to the Numerical Index is assigned by the appropriate Air Force representatives. In this parts breakdown, no source codes are supplied.

**PART NUMBER.**

6-19 This column contains the figure and index number where the applicable part appears in the Main Assembly Parts List.

**QUANTITY PER ARTICLE.**

6-20 The quantity appearing in this column is the total quantity of the part used in this equipment.

**REFERENCE DESIGNATION INDEX.**

6-21 The Reference Designation Index (Section 9) provides rapid cross-referencing between parts shown on schematic wiring diagrams (contained in the applicable adjustment and replacement instructions) and parts listed in the Main Assembly Parts List. The reference designations are arranged in alphabetical and numerical order and are cross-referenced to:

1. Figure and Index Number
2. Class Code or Stock Number
3. Part Number

**HOW TO USE THIS PARTS BREAKDOWN**

**HOW TO FIND THE DESCRIPTION IF THE PART NUMBER IS KNOWN:**

6-22 Turn to the Numerical Index (Section 8) and find the figure and index number where the part number appears in the Main Assembly Parts List to determine the complete description.

**HOW TO FIND THE PART NUMBER AND DESCRIPTIONS WHEN THE REFERENCE DESIGNATION IS KNOWN:**

6-23 Turn to the Reference Designation Index (Section 9) and find the part number and the figure and index

number where the part is listed in the Main Assembly Parts List to determine the complete description.

**VENDORS' CODES**

6-24 Listed below are the numerical codes used to identify the actual manufacturer of a part. Codes and addresses are in accordance with Federal Supply Code for Manufacturers H4-1.

CODE NUMBER	VENDORS' NAME AND ADDRESS
01121	Allen-Bradley Co., Milwaukee, Wis.
03614	Bussmann Fuse Division of McGraw-Edison Co., Los Angeles, Calif.
04645	Kurz-Kasch, Inc., Chicago, Ill.
14655	Cornell-Dubilier Electric Corp., South Plainfield, N.J.
63743	Ward Leonard Electric Co., Mount Vernon, N.Y.
71468	Cannon Electric Co., Los Angeles, Calif.
71785	Cinch Mfg. Corp., Chicago, Ill.
72512	Davies, Harry, Molding Co., Chicago, Ill.
72794	Dzus Fastener Co., Inc. Babylon, N.Y.
72825	Eby, Hugh H., Inc., Philadelphia, Pa.
72982	Erie Resistor Corp., Erie, Pa.
73359	Detroit Sales Engineering Corp., Detroit, Mich.
74970	Johnson, E.F., Co., Waseca, Minn.
75915	Littelfuse, Inc., Des Plaines, Ill.
76487	Millen, James, Mfg. Co., Inc., Malden, Mass.
76500	Miller Rubber Division of Goodrich, B.F. Co., Akron, Ohio
76854	Oak Mfg. Co., Chicago, Ill.

CODE NUMBER	VENDORS' NAME AND ADDRESS	CODE NUMBER	VENDORS' NAME AND ADDRESS
78488	Stackpole Carbon Co., St. Marys, Pa.	85599	General Electric Co., Power Tube Department of Electronic Components Division of Electronic, Atomic and Defense Systems Group, Schenectady, N.Y.
80583	Hammarlund Co., Inc., New York, N.Y.	88063	Communication Accessories Co., Lees Summit, Mo.
82679	Technical Materiel Corp., The, Mamaroneck, N.Y.	89032	Tinnerman Products Inc., New York, N.Y.
83330	Smith, Herman H. Inc., Brooklyn, N.Y.	89870	Berkshire Transformer Corp., New Milford, Conn.
84171	Arco Electronics, Inc., New York, N.Y.	90201	Mallory, P.R., and Co., Inc., Detroit, Mich.



SECTION 7

MAIN ASSEMBLY PARTS LIST

FIGURE AND INDEX NUMBER	PART NUMBER	DESCRIPTION	VENDOR CODE	UNITS PER ASSY	USABLE ON CODE
7-1-1 -2	GPR-90 GPR-90RX	GPR-90 AND GPR-90RX RADIO RECEIVER			
		RADIO RECEIVER (SEE FIG. 2 FOR BREAKDOWN) . . . . .		1	A
		RADIO RECEIVER (SEE FIG. 2 FOR BREAKDOWN) . . . . .		1	B

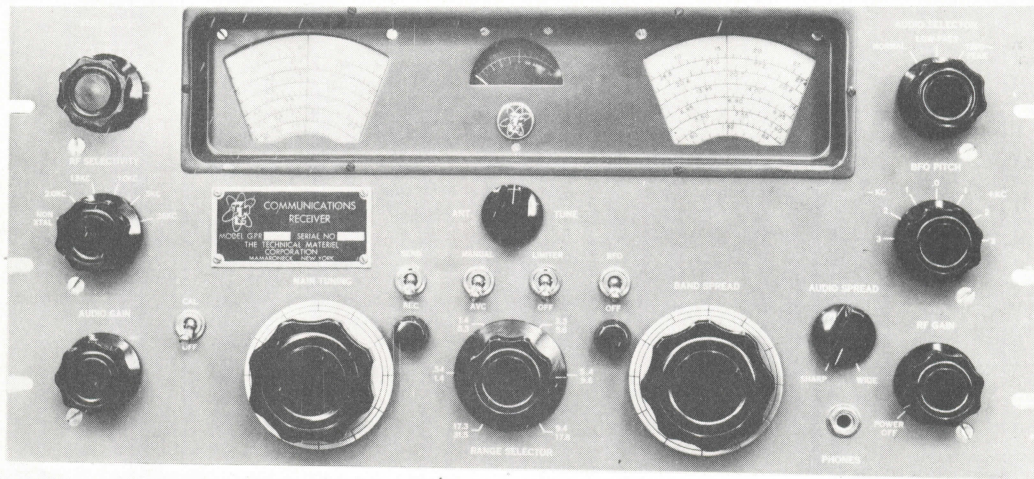

← 1

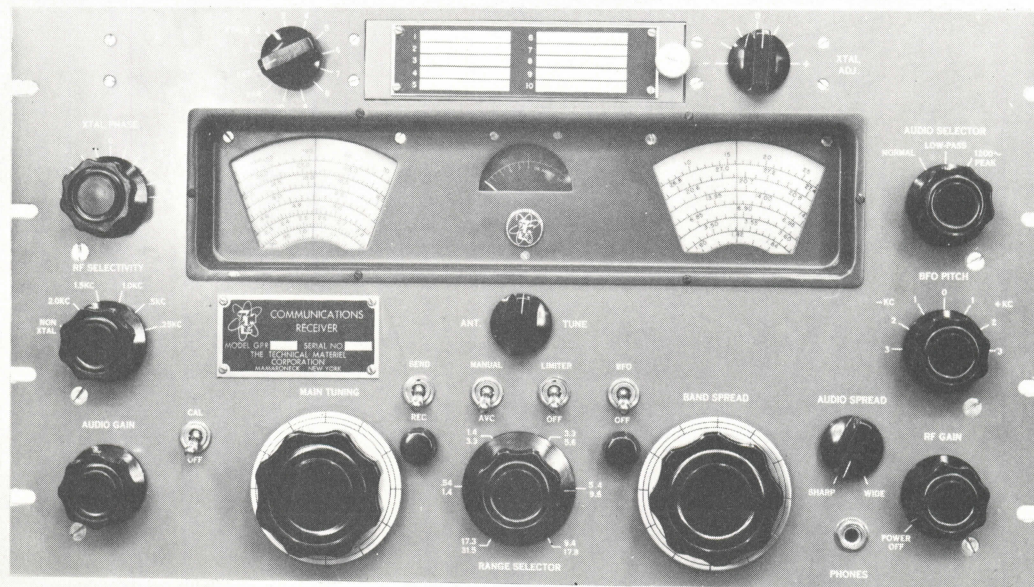

← 2

FIGURE 7-1. GPR-90 AND GPR-90RX RADIO RECEIVERS

FIGURE AND INDEX NUMBER	PART NUMBER	DESCRIPTION	VENDOR CODE	UNITS PER ASSY	US-ABLE ON CODE
		RADIO RECEIVER			
7-2-	GPR-90	RECEIVER, RADIO (SEE FIG. 7-1-1 FOR NEXT HIGHER ASSEMBLY)	82679	1	A
-1	GPR-90RX	RECEIVER, RADIO (SEE FIG. 7-1-2 FOR NEXT HIGHER ASSEMBLY)	82679	1	B
	MS-639	. COVER, TOP . . . . .	82679	1	A
	MS-1140	. COVER, TOP . . . . .	82679	1	B
		(ATTACHING PARTS)			
	SCBS0632BN5	. SCREW, MACHINE, 6-32 BY 5/16 IN. . . . .	82679	4	
	LW106MRN	. WASHER, LOCK, NO. 6 . . . . .	82679	4	
		----*----			
-2	MS-640	. COVER, BOTTOM . . . . .	82679	1	
		(ATTACHING PARTS)			
	SCBS0632BN5	. SCREW, MACHINE, 6-32 BY 5/16 IN. . . . .	82679	6	
	LW106MRN	. WASHER, LOCK, NO. 6 . . . . .	82679	6	
		----*----			
-3	MS-1131	. COVER, CRYSTAL CHASSIS . . . . .	82679	1	B
		(ATTACHING PARTS)			
	SCBS0632BN5	. SCREW, MACHINE, 6-32 BY 5/16 IN. . . . .	82679	5	B
	C8091-632-67	. NUT, SHEET SPRING . . . . .	89032	5	B
		----*----			
-4	MP-108-2	. KNOB . . . . .	82679	6	
-5	RV4BTRD502E	. RESISTOR, VARIABLE (MIL-R-94) . . . . .		1	
-6	RV4ATRDI05D	. RESISTOR, VARIABLE (MIL-R-94) . . . . .		1	
-7	TE-111-1	. TERMINAL, LUG . . . . .	82679	2	
-8	705	. JACK, TELEPHONE . . . . .	90201	1	
-9	MP-109-1	. KNOB . . . . .	82679	1	
-10	RV4ATSC152B	. RESISTOR, VARIABLE (MIL-R-94) . . . . .		1	
-11	4103-AD	. KNOB . . . . .	72512	2	
-12	MS-631	. DIAL, CONTROL . . . . .	82679	2	
		(ATTACHING PARTS)			
	SCBS0632BN5	. SCREW, MACHINE, 6-32 BY 5/16 IN. . . . .	82679	6	
	LWS06MRN	. WASHER, LOCK, NO. 6 . . . . .	82679	6	
		----*----			

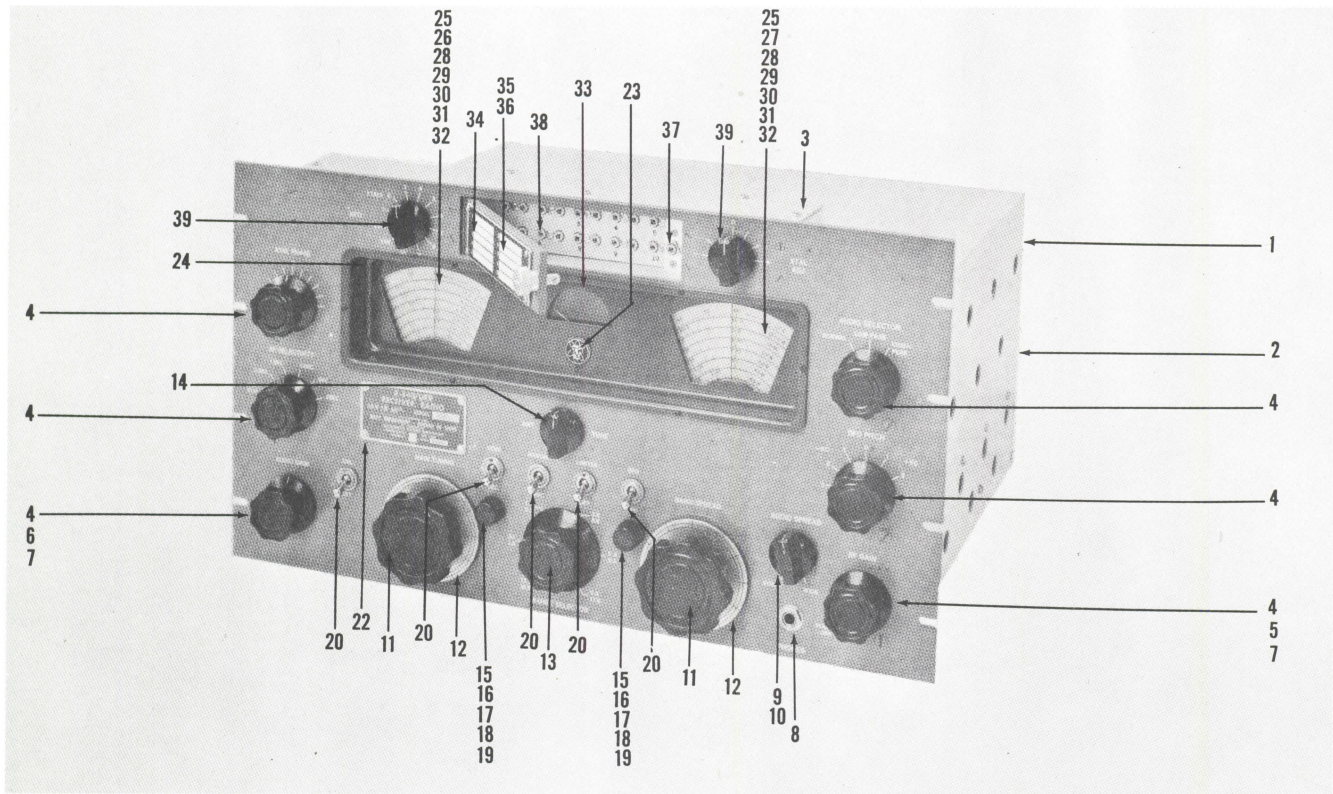

FIGURE 7-2. RADIO RECEIVER, FRONT VIEW (SHEET 1 OF 6, INDEX NOS. 1 THRU 39)

FIGURE AND INDEX NUMBER	PART NUMBER	DESCRIPTION	VENDOR CODE	UNITS PER ASSY	US-ABLE ON CODE
RADIO RECEIVER (CONT)					
7-2-13	S-311-64-BB-DD-L	• KNOB . . . . .	04645	1	
-14	MP-109-2	• KNOB . . . . .	82679	1	
-15	1450JA	• KNOB . . . . .	72512	2	
-16	PM-338	• SHAFT, STRAIGHT (ATTACHING PARTS)	82679	2	
	SM-127-D-1032	• NUT, STOP, HEX . . . . .	82679	2	
	K-10094-2	• RING, RETAINING . . . . .	80583	2	
	WA-115	• WASHER, CLINCH . . . . .	82679	2	
		-----*			
-17	PM-341	• PIN, DIAL LOCKING . . . . . (ATTACHING PARTS)	82679	2	
	NTH0632BN8	• NUT, PLAIN, HEX, 6-32 BY 1/4 IN.	82679	4	
	FW06HBN	• WASHER, FLAT, NO. 6 . . . . .	82679	2	
	LWE06MRN	• WASHER, LOCK, NO. 6 . . . . .	82679	4	
		-----*			
-18	PM-224	• WASHER, KEYWAY . . . . .	82679	2	
-19	PM-225	• WASHER, KEYWAY . . . . .	82679	2	
-20	T-110-62	• SWITCH, TOGGLE . . . . .	73359	5	
-21	TE-149-144	• TERMINAL, LUG . . . . .	82679	1	
-22	NP-196-1	• PLATE, IDENTIFICATION (ATTACHING PARTS)	82679	1	B
	SFB0256SK3	• SCREW, TAPPING, 2-56 BY 3/16 IN. -----*	82679	4	B

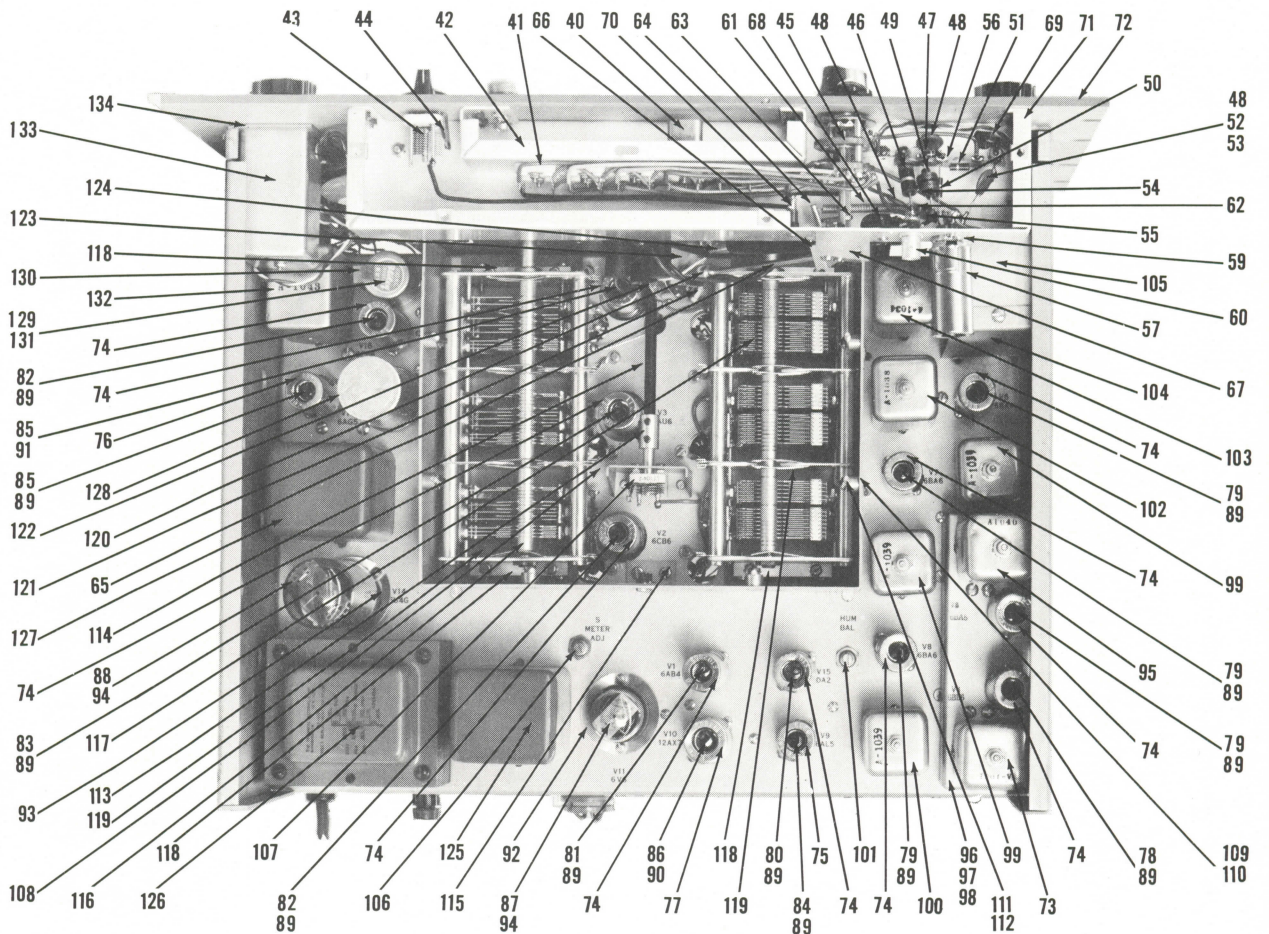

FIGURE 7-2. RADIO RECEIVER, TOP VIEW (SHEET 2 OF 6, INDEX NOS. 40 THRU 134)

FIGURE AND INDEX NUMBER	PART NUMBER	DESCRIPTION	VENDOR CODE	UNITS PER ASSY	US-ABLE ON CODE
					1 2 3 4 5 6 7
RADIO RECEIVER (CONT)					
7-2-23 -24	NP-136	• PLATE, IDENTIFICATION . . . . .	82679	1	
	MS-623	• ESCUTCHEON . . . . . (ATTACHING PARTS)	82679	1	
	SFB0256SK3	• SCREW, TAPPING, 2-56 BY 3/16 IN. . . . . ----*----	82679	6	
-25	PX-264	• DIAL, SCALE . . . . . (ATTACHING PARTS)	82679	2	
	SCFS0440BN8 2153	• SCREW, MACHINE, 4-40 BY 1/2 IN. . . . .	82679	4	
	WA-109-56	• WASHER . . . . .	83330	8	
	LWE04MRN	• WASHER . . . . .	82679	8	
	FW04HBN	• WASHER, LOCK, NO. 4 . . . . .	82679	4	
	NTH0440BN8	• WASHER, FLAT, NO. 4 . . . . .	82679	4	
		• NUT, PLAIN, HEX, 4-40 BY 1/4 IN. . . . . ----*----	82679	4	
-26	A-1024-1	• DIAL, CONTROL . . . . .	82679	1	
-27	A-1024-3	• DIAL, CONTROL . . . . .	82679	1	
-28	GR-122	• GEARSHAFT, SPUR . . . . .	82679	2	
-29	SP-122	• SPRING, HELICAL . . . . .	82679	2	
-30	GR-123	• GEAR, SPUR . . . . .	82679	2	
-31	PM-325	• SHAFT, STRAIGHT . . . . .	82679	2	
-32	PM-326	• SHAFT, STRAIGHT . . . . .	82679	2	

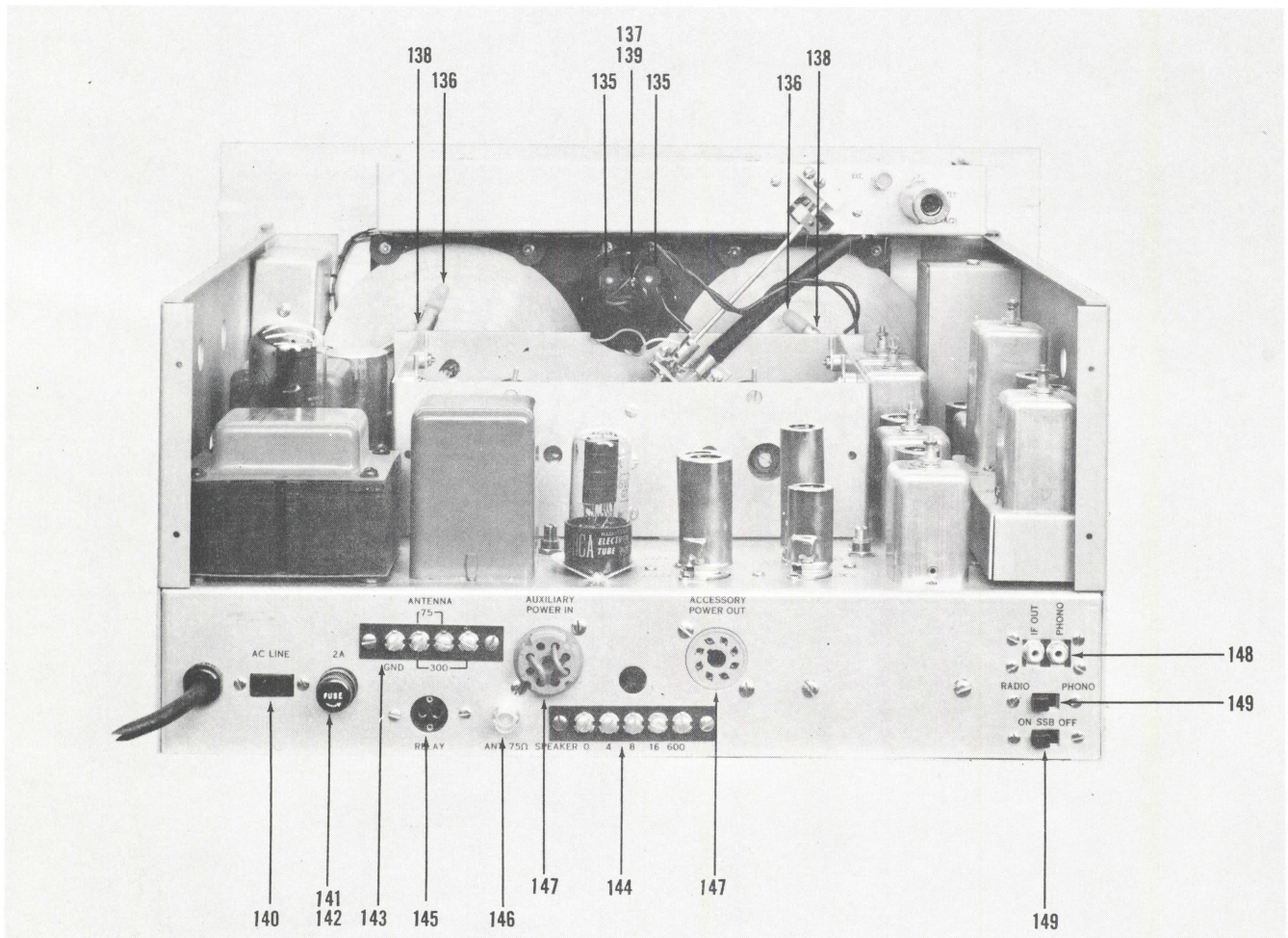

FIGURE 7-2. RADIO RECEIVER, BACK VIEW (SHEET 3 OF 6, INDEX NOS. 135 THRU 149)

FIGURE AND INDEX NUMBER	PART NUMBER	DESCRIPTION	VENDOR CODE	UNITS PER ASSY	US-ABLE
					ON CODE
		1 2 3 4 5 6 7			
		RADIO RECEIVER (CONT)			
7-2-33	MR-107	. METER . . . . .	82679	1	
		(ATTACHING PARTS)			
	SCFS0256BN5	. SCREW, MACHINE, 2-56 BY 5/16 IN. . . . .	82679	3	
	LWS02MRN	. WASHER, LOCK, NO. 2 . . . . .	82679	3	
	FW02HBN	. WASHER, FLAT, NO. 2 . . . . .	82679	3	
	NTH0256BN6	. NUT, PLAIN, HEX, 2-56 BY 3/16 IN. . . . .	82679	3	
	C6227-632-67	. NUT, SHEET SPRING . . . . .	82679	3	
		---*---			
-34	NP-205	. PLATE, FREQUENCY . . . . .	82679	1	B
		(ATTACHING PARTS)			
	SFB0256SK3	. SCREW, TAPPING, 2-56 BY 3/16 IN. . . . .	82679	4	B
		---*---			
-35	KJ4-45X247	. STUD, TURNLOCK FASTENER . . . . .	72794	1	B
-36	4	. RING, RETAINING . . . . .	72794	1	B
-37	S4-200	. LOCKSPRING . . . . .	72794	1	B
		(ATTACHING PARTS)			
	SCFS0348BN4	. SCREW, MACHINE, 3-48 BY 1/4 IN. . . . .	82679	2	B
	LWS03MRN	. WASHER, LOCK, NO. 3 . . . . .	82679	2	B
	NTH0348BN6	. NUT, PLAIN, HEX, 3-48 BY 3/16 IN. . . . .	82679	2	B
		---*---			
-38	MS-1127	. DOOR, CRYSTAL . . . . .	82679	1	B
		(ATTACHING PARTS)			
	PN-111	. PIN, LOCKING . . . . .	82679	2	B
	WA-101-4	. WASHER . . . . .	82679	1	B
		---*---			

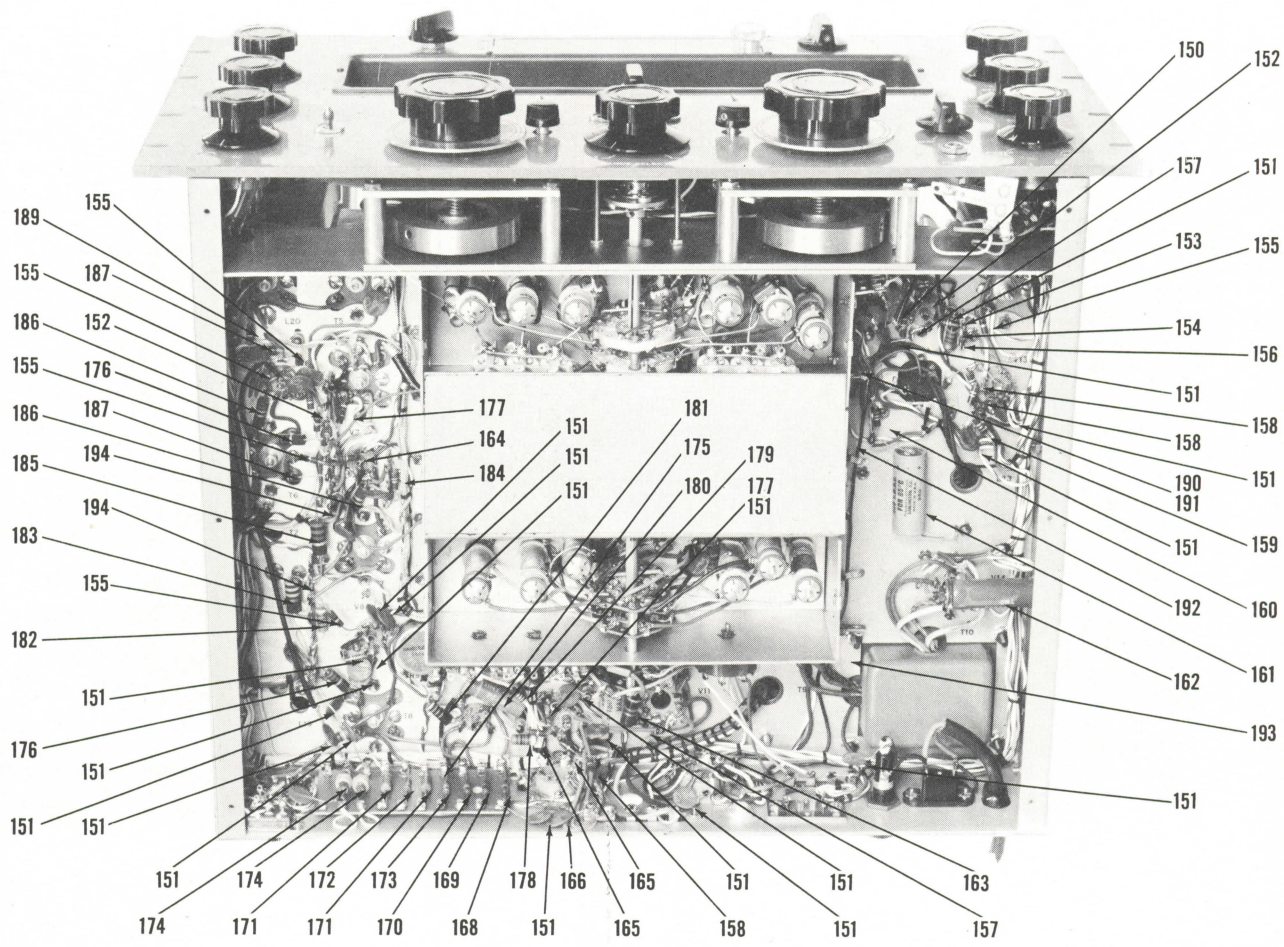

FIGURE 7-2. RADIO RECEIVER, BOTTOM VIEW, (SHEET 4 OF 6, INDEX NOS. 150 THRU 194)

FIGURE AND INDEX NUMBER	PART NUMBER	DESCRIPTION							VENDOR CODE	UNITS PER ASSY	USABLE ON CODE
		1	2	3	4	5	6	7			
RADIO RECEIVER (CONT)											
7-2-39	MP-109-2	.	.	.	.	.	.	.	82679	2	B
-40	CR-18/U	.	.	.	.	.	.	.	82679	10	B
-41	8879	.	.	.	.	.	.	.	82679	10	B
	SCBS0440BN8	.	.	.	.	.	.	.	82679	10	B
	LWS04MRN	.	.	.	.	.	.	.	82679	10	B
	WA-109-17	.	.	.	.	.	.	.	82679	10	B
	NTH0440BN6	.	.	.	.	.	.	.	82679	10	B
		----	*	----							
-42	MS-1132	.	.	.	.	.	.	.	82679	1	B
	SCFS0440BNS	.	.	.	.	.	.	.	82679	4	B
	LWE04MRN	.	.	.	.	.	.	.	82679	4	B
	FW04HBN	.	.	.	.	.	.	.	82679	4	B
	NTH0440BN8	.	.	.	.	.	.	.	82679	4	B
		----	*	----							
-43	CT-104-1	.	.	.	.	.	.	.	82679	1	B
	SCFS0440BN4	.	.	.	.	.	.	.	82679	2	B
		----	*	----							
-44	TE-116-1	.	.	.	.	.	.	.	82679	1	B
-45	SW-222	.	.	.	.	.	.	.	82679	1	B
-46	RC42GF680K	.	.	.	.	.	.	.		1	B
-47	RC32GF223K	.	.	.	.	.	.	.		1	B

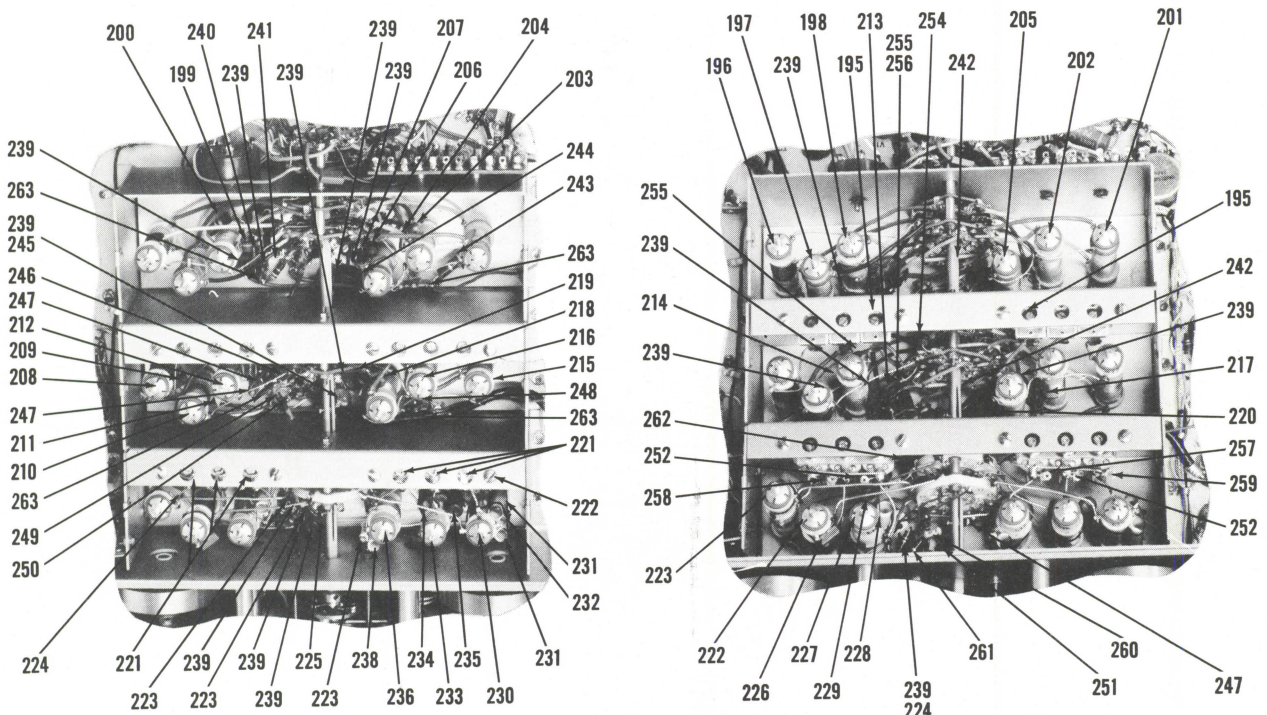

FIGURE 7-2. RADIO RECEIVER, BOTTOM VIEW (SHEET 5 OF 6, INDEX NOS. 195 THRU 263)



FIGURE AND INDEX NUMBER	PART NUMBER	DESCRIPTION	VENDOR CODE	UNITS PER ASSY	US- ABLE ON CODE
		RADIO RECEIVER (CONT)			
7-2-62	TE-149-120	. TERMINAL, LUG . . . . .	82679	1	B
		(ATTACHING PARTS)			
	SCBS0440BN4	. SCREW, MACHINE, 4-40 BY 1/4 IN. . . . .	82679	1	B
	LWE04MRN	. WASHER, LOCK, NO. 4 . . . . .	82679	1	B
	NTH0440BN8	. NUT, PLAIN, HEX, 4-40 BY 1/4 IN. . . . .	82679	1	B
		---*---			
-63	PN-108	. PIN, STRIKER . . . . .	82679	1	B
-64	PN-112	. PIN, STRIKER . . . . .	82679	1	B
-65	PM-460-5.00BN	. SHAFT, STRAIGHT . . . . .	82679	1	B
-66	PM-463	. SWITCH, LINKAGE . . . . .	82679	1	B
		(ATTACHING PARTS)			
	AN565D4H3	. SETSCREW . . . . .		1	B
		---*---			
-67	PM-462	. SHAFT, SUPPORT . . . . .	82679	1	B
		(ATTACHING PARTS)			
	SCBS0440BN4	. SCREW, MACHINE, 4-40 BY 1/4 IN. . . . .	82679	2	B
	FW04HBN	. WASHER, FLAT, NO. 4 . . . . .	82679	2	B
	LWE04MRN	. WASHER, LOCK, NO. 4 . . . . .	82679	2	B
	NTH0440BN8	. NUT, PLAIN, HEX, 4-40 BY 1/4 IN. . . . .	82679	2	B
		---*---			
-68	1045	. STRAP, RETAINING . . . . .	71785	1	B
		(ATTACHING PARTS)			
	SCBS0440BN4	. SCREW, MACHINE, 4-40 BY 1/4 IN. . . . .	82679	1	B
	FW04HBN	. WASHER, FLAT, NO. 4 . . . . .	82679	1	B
	LWE04MRN	. WASHER, LOCK, NO. 4 . . . . .	82679	1	B
	NTH0440BN8	. NUT, PLAIN, HEX, 4-40 BY 1/4 IN. . . . .	82679	1	B
		---*---			
-69	GB-2252	. GROMMET, RUBBER . . . . .	76500	1	B
-70	T103A-2	. TERMINAL, STUD . . . . .	92825	1	B
		(ATTACHING PARTS)			
	SCBS0440BN3	. SCREW, MACHINE, 4-40 BY 3/16 IN. . . . .	82679	1	B
	LWE04MRN	. WASHER, LOCK, NO. 4 . . . . .	82679	1	B
		---*---			
-71	MS-1130	. CHASSIS, ELECTRICAL EQUIPMENT . . . . .	82679	1	B
		(ATTACHING PARTS)			
	SCFS0440BN8	. SCREW, MACHINE, 4-40 BY 1/2 IN. . . . .	82679	4	B
	LWE04MRN	. WASHER, LOCK, NO. 4 . . . . .	82679	4	B
	NTH0440BN8	. NUT, PLAIN, HEX, 4-40 BY 1/4 IN. . . . .	82679	4	B
		---*---			
-72	MS-607	. PANEL, TEST . . . . .	82679	1	A
	MS-1128	. PANEL, TEST . . . . .	82679	1	B
		(ATTACHING PARTS)			
	SCFS0832BN6	. SCREW, MACHINE, 8-32 BY 3/8 IN. . . . .	82679	6	
	LWE08MRN	. WASHER, LOCK, NO. 8 . . . . .	82679	6	
	NTH0832BN10	. NUT, PLAIN, HEX, 8-32 BY 5/16 IN. . . . .	82679	6	
		---*---			
-73	A-1041	. COIL, RADIO FREQUENCY . . . . .	82679	1	
		(ATTACHING PARTS)			
	SCBS0632BN5	. SCREW, MACHINE, 6-32 BY 5/16 IN. . . . .	82679	2	
	LWE06MRN	. WASHER, LOCK, NO. 6 . . . . .	82679	4	
	NTH0632BN8	. NUT, PLAIN, HEX, 6-32 BY 1/4 IN. . . . .	82679	2	
		---*---			
-74	TS102U02	. SHIELD, ELECTRON TUBE (JAN-S-28A). . . . .		11	
-75	TS102U01	. SHIELD, ELECTRON TUBE (JAN-S-28A). . . . .		1	
-76	TS102U03	. SHIELD, ELECTRON TUBE (JAN-S-28A). . . . .		1	
-77	TS103U02	. SHIELD, ELECTRON TUBE (JAN-S-28A). . . . .		1	
-78	6BE6	. ELECTRON TUBE . . . . .	85599	1	
-79	6BA6	. ELECTRON TUBE . . . . .	85599	4	
-80	0A2	. ELECTRON TUBE . . . . .	85599	1	
-81	6AB4	. ELECTRON TUBE . . . . .	85599	1	
-82	6CB6	. ELECTRON TUBE . . . . .	85599	2	
-83	6AU6	. ELECTRON TUBE . . . . .	85599	1	
-84	6AL5	. ELECTRON TUBE . . . . .	85599	1	
-85	6AG5	. ELECTRON TUBE . . . . .	85599	2	
-86	12AX7	. ELECTRON TUBE . . . . .	85599	1	
-87	6V6	. ELECTRON TUBE . . . . .	85599	1	
-88	5U4G	. ELECTRON TUBE . . . . .	85599	1	
-89	TS102P01	. SOCKET, ELECTRON TUBE (JAN-S-28A). . . . .		12	
-90	TS103P01	. SOCKET, ELECTRON TUBE (JAN-S-28A). . . . .		1	

FIGURE AND INDEX NUMBER	PART NUMBER	DESCRIPTION	VENDOR CODE	UNITS PER ASSY	US- ABLE ON CODE	
						1 2 3 4 5 6 7
		RADIO RECEIVER (CONT)				
7-2-91	TS102C01	. SOCKET, ELECTRON TUBE (JAN-S-28A) . . . . .		1		
	SCBS0440BN5	(ATTACHING PARTS)				
	LWS04MRN	. SCREW, MACHINE, 6-32 BY 5/16 IN. . . . .	82679	28		
	NTH0440BN6	. WASHER, LOCK, NO. 4 . . . . .	82679	28		
		. NUT, PLAIN, HEX, 4-40 BY 3/16 IN. . . . .	82679	28		
		----*----				
-92	8599	. RETAINER, ELECTRON TUBE . . . . .	71785	1		
-93	8517	. RETAINER, ELECTRON TUBE . . . . .	71785	1		
-94	51B13405	. SOCKET, ELECTRON TUBE . . . . .	71785	2		
		(ATTACHING PARTS)				
	SCBS0632BN5	. SCREW, MACHINE, 6-32 BY 5/16 IN. . . . .	82679	4		
	LWE06MRN	. WASHER, LOCK, NO. 6 . . . . .	82679	4		
	NTH0632BN8	. NUT, PLAIN, HEX, 6-32 . . . . .	82679	4		
		----*----				
-95	A-1040	. TRANSFORMER, RADIO FREQUENCY . . . . .	82679	1		
		(ATTACHING PARTS)				
	SCBS0632BN5	. SCREW, MACHINE, 6-32 BY 5/16 IN. . . . .	82679	2		
	LWE06MRN	. WASHER, LOCK, NO. 6 . . . . .	82679	4		
	NTH0632BN8	. NUT, PLAIN, HEX, 6-32 BY 1/4 IN. . . . .	82679	2		
		----*----				
-96	MS-593	. CHASSIS, ELECTRICAL EQUIPMENT . . . . .	82679	1		
		(ATTACHING PARTS)				
	SCBS0632BN12	. SCREW, MACHINE, 6-32 BY 3/4 IN. . . . .	82679	2		
	LWE06MRN	. WASHER, LOCK, NO. 6 . . . . .	82679	2		
	3482-11	. WASHER, FLAT . . . . .	76854	2		
	NTH0632BN8	. NUT, PLAIN, HEX, 6-32 BY 1/4 IN. . . . .	82679	2		
		----*----				
-97	MS-624	. COVER, BOTTOM . . . . .	82679	1		
		(ATTACHING PARTS)				
	SCBS0632BN7	. SCREW, MACHINE, 6-32 BY 7/16 IN. . . . .	82679	2		
	LWE06MRN	. WASHER, LOCK, NO. 6 . . . . .	82679	2		
	3482-11	. WASHER, FLAT . . . . .	76854	2		
	NTH0632BN8	. NUT, PLAIN, HEX, 6-32 BY 1/4 IN. . . . .	82679	2		
		----*----				
-98	TE-135-5	. NUT, SLEEVE . . . . .	82679	2		
		(ATTACHING PARTS)				
	SCBS0632BN5	. SCREW, MACHINE, 6-32 BY 5/16 IN. . . . .	82679	4		
	LWE06MRN	. WASHER, LOCK, NO. 6 . . . . .	82679	4		
		----*----				
-99	A-1039-1-2	. TRANSFORMER, RADIO FREQUENCY . . . . .	82679	2		
-100	A-1039-3	. TRANSFORMER, RADIO FREQUENCY . . . . .	82679	1		
		(ATTACHING PARTS)				
	SCBS0632BN5	. SCREW, MACHINE, 6-32 BY 5/16 IN. . . . .	82679	6		
	LWE06MRN	. WASHER, LOCK, NO. 6 . . . . .	82679	6		
	NTH0632BN8	. NUT, PLAIN, HEX, 6-32 BY 1/4 IN. . . . .	82679	6		
		----*----				
-101	RA101ASSA251A	. RESISTOR, VARIABLE (MIL-R-19) . . . . .		1		
-102	A-1038	. TRANSFORMER, RADIO FREQUENCY . . . . .	82679	1		
-103	A-1034	. TRANSFORMER, RADIO FREQUENCY . . . . .	82679	1		
		(ATTACHING PARTS)				
	SCBS0632BN5	. SCREW, MACHINE, 6-32 BY 5/16 IN. . . . .	82679	4		
	LWE06MRN	. WASHER, LOCK, NO. 6 . . . . .	82679	4		
	NTH0632BN8	. NUT, PLAIN, HEX, 6-32 BY 1/4 IN. . . . .	82679	4		
		----*----				
-104	A-1025	. COVER, CRYSTAL . . . . .	82679	1		
		(ATTACHING PARTS)				
	SCBS0632BN5	. SCREW, MACHINE, 6-32 BY 5/16 IN. . . . .	82679	1		
	LWE06MRN	. WASHER, LOCK, NO. 6 . . . . .	82679	2		
	NTH0632BN8	. NUT, PLAIN, HEX, 6-32 BY 1/4 IN. . . . .	82679	2		
		----*----				
-105	A-1037	. CRYSTAL ASSY, (SEE FIG. 7-3 FOR BREAKDOWN) . . . . .	82679	1		
		(ATTACHING PARTS)				
	SCBS1032BN5	. SCREW, MACHINE, 10-32 BY 5/16 IN. . . . .	82679	2		
	SCBS0632BN5	. SCREW, MACHINE, 6-32 BY 5/16 IN. . . . .	82679	2		
	LWE10MRN	. WASHER, LOCK, NO. 10 . . . . .	82679	2		
	LWE06MRN	. WASHER, LOCK, NO. 6 . . . . .	82679	2		
		----*----				
-106	RV4ATS103B	. RESISTOR, VARIABLE (MIL-R-94) . . . . .		1		

FIGURE AND INDEX NUMBER	PART NUMBER	DESCRIPTION	VENDOR CODE	UNITS PER ASSY	US- ABLE ON CODE
RADIO RECEIVER (CONT)					
7-2-107	CT-104-5	. CAPACITOR, VARIABLE, AIR . . . . .	82679	1	
		(ATTACHING PARTS)			
	SCBS0440BN3	. SCREW, MACHINE, 4-40 BY 3/16 IN. . . . .	82679	2	
	LWE04MRN	. WASHER, LOCK, NO. 4 . . . . .	82679	2	
		---*---			
-108	MS-584	. RETAINER . . . . .	82679	1	
		(ATTACHING PARTS)			
	SCBS0632BN4	. SCREW, MACHINE, 6-32 BY 1/4 IN. . . . .	82679	2	
	LWE06MRN	. WASHER, LOCK, NO. 6 . . . . .	82679	4	
	NTH0632BN8	. NUT, PLAIN, HEX, 6-32 BY 1/4 IN. . . . .	82679	2	
		---*---			
-109	MS-618	. COVER . . . . .	82679	1	A
	MS-1136	. COVER . . . . .	82679	1	B
		(ATTACHING PARTS)			
	NT-104-1	. NUT, KNURLED . . . . .	82679	6	
		---*---			
-110	A-983	. ENCLOSURE . . . . .	82679	1	
		(ATTACHING PARTS)			
	SCBS0632BN9	. SCREW, MACHINE, 6-32 BY 9/16 IN. . . . .	82679	4	
	LWE06MRN	. WASHER, LOCK, NO. 6 . . . . .	82679	16	
	NTH0632BN8	. NUT, PLAIN, HEX, 6-32 BY 1/4 IN. . . . .	82679	12	
		---*---			
-111	SC-106-1	. . BOLT, EYE . . . . .	82679	6	
		(ATTACHING PARTS)			
	SCFS0632BN8	. . SCREW, MACHINE, 6-32 BY 1/2 IN. . . . .	82679	6	
	LWE06MRN	. . WASHER, LOCK, NO. 6 . . . . .	82679	6	
	NTH0632BN8	. . NUT, PLAIN, HEX, 6-32 BY 1/4 IN. . . . .	82679	6	
		---*---			
-112	TE-117-11	. . SPACER, SLEEVE . . . . .	82679	6	
-113	1066AX	. COUPLING, SHAFT . . . . .	83330	1	
		(ATTACHING PARTS)			
	AN565D6H3	. SETSCREW . . . . .		4	
		---*---			
-114	PX-284	. SHAFT, STRAIGHT . . . . .	82679	1	
-115	MS953	. BRACKET, ANGLE . . . . .	82679	1	
		(ATTACHING PARTS)			
	SCBS0632BN5	. SCREW, MACHINE, 6-32 BY 5/16 IN. . . . .	82679	4	
	LWE06MRN	. WASHER, LOCK, NO. 6 . . . . .	82679	6	
	FW06HBN	. WASHER, FLAT, NO. 6 . . . . .	82679	2	
	NTH0632BN8	. NUT, PLAIN, HEX, 6-32 BY 1/4 IN. . . . .	82679	4	
		---*---			
-116	CB-131	. CAPACITOR, VARIABLE, AIR . . . . .	82679	1	
-117	CB-130	. CAPACITOR, VARIABLE, AIR . . . . .	82679	1	
		(ATTACHING PARTS)			
	SCBS0632BN8	. SCREW, MACHINE, 6-32 BY 1/2 IN. . . . .	82679	8	
	LWE06MRN	. WASHER, LOCK, NO. 6 . . . . .	82679	8	
		---*---			
-118	PM-496	. MOUNTING BAR . . . . .	82679	4	
		(ATTACHING PARTS)			
	SCBS0632BN10	. SCREW, MACHINE, 6-32 BY 5/8 IN. . . . .	82679	8	
	LWE06MRN	. WASHER, LOCK, NO. 6 (82679) . . . . .	82679	16	
	NTH0632BN8	. NUT, PLAIN, HEX, 6-32 BY 1/4 IN. . . . .	82679	8	
		---*---			
-119	PX-413	. INSULATOR, PLATE . . . . .	82679	2	
-120	PM-461	. COUPLING, SHAFT . . . . .	82679	1	B
		(ATTACHING PARTS)			
	AN565D4H2	. SETSCREW . . . . .		2	B
		---*---			
-121	CC26CH300J	. CAPACITOR, FIXED, CERAMIC (JAN-C-20A) . . . . .		1	B
-122	SW-203	. SWITCH, ROTARY . . . . .	82679	1	B
-123	MS-1133	. BRACKET, ANGLE . . . . .	82679	1	B
		(ATTACHING PARTS)			
	SCBS0440BN4	. SCREW, MACHINE, 4-40 BY 1/4 IN. . . . .	82679	2	B
	FW04HBN	. WASHER, FLAT, NO. 4 . . . . .	82679	2	B
		---*---			
-124	1045	. STRAP, RETAINING . . . . .	71785	1	B
		(ATTACHING PARTS)			
	SCBS0440BN4	. SCREW, MACHINE, 4-40 BY 1/4 IN. . . . .	82679	1	B
	FW04HBN	. WASHER, FLAT, NO. 4 . . . . .	82679	1	B
		---*---			

FIGURE AND INDEX NUMBER	PART NUMBER	DESCRIPTION	VENDOR CODE	UNITS PER ASSY	US-ABLE ON CODE
RADIO RECEIVER (CONT)					
7-2-125	TF-159	. TRANSFORMER, AUDIO FREQUENCY . . . . .	82679	1	
	NTH0632BN8	(ATTACHING PARTS)			
	LWE06MRN	. NUT, PLAIN, HEX, 6-32 BY 1/4 IN. . . . .	82679	2	
		. WASHER, LOCK, NO. 6 . . . . .	82679	2	
		---*---			
-126	TF-169	. TRANSFORMER, POWER, STEP-DOWN AND STEP-UP . . . . .	82679	1	
	NTH0832BN10	(ATTACHING PARTS)			
	LWE08MRN	. NUT, PLAIN, HEX, 8-32 BY 5/16 IN. . . . .	82679	4	
		. WASHER, LOCK, NO. 8 . . . . .	82679	4	
		---*---			
-127	2277B	. REACTOR . . . . .	89870	1	
	NTH0632BN8	(ATTACHING PARTS)			
	LWE06MRN	. NUT, PLAIN, HEX, 6-32 BY 1/2 IN. . . . .	82679	2	
		. WASHER, LOCK, NO. 6 . . . . .	82679	2	
		---*---			
-128	UPT-4445	. CAPACITOR, FIXED, ELECTROLYTIC . . . . .	14655	1	
	SCBS0632BN4	(ATTACHING PARTS)			
	LWE06MRN	. SCREW, MACHINE, 6-32 BY 1/4 IN. . . . .	82679	2	
	NTH0632BN8	. WASHER, LOCK, NO. 6 . . . . .	82679	2	
		. NUT, PLAIN, HEX, 6-32 BY 1/4 IN. . . . .	82679	2	
		---*---			
-129	CR-100	. CRYSTAL UNIT . . . . .	82679	1	
-130	CU-106	. RETAINER . . . . .	82679	1	
-131	K-33102	. HOLDER, CRYSTAL UNIT . . . . .	76487	1	
	SCBS0440BN10	(ATTACHING PARTS)			
	LWE04MRN	. SCREW, MACHINE, 4-40 BY 5/8 IN. . . . .	82679	2	
	WA-109-17	. WASHER, LOCK, NO. 4 . . . . .	82679	2	
	NTH0440BN6	. WASHER . . . . .	82679	2	
		. NUT, PLAIN, HEX, 4-40 BY 3/16 IN. . . . .	82679	2	
		---*---			
-132	A-1043	. COIL, RADIO FREQUENCY (SEE FIG. 7-4 FOR BREAKDOWN) . . . . .	82679	1	
	SCBS0632BN5	(ATTACHING PARTS)			
	LWE06MRN	. SCREW, MACHINE, 6-32 BY 5/16 IN. . . . .	82679	2	
	NTH0632BN8	. WASHER, LOCK, NO. 6. . . . .	82679	4	
		. NUT, PLAIN, HEX, 6-32 BY 1/4 IN. . . . .	82679	2	
		---*---			
-133	A-924	. NETWORK ASSY, AUDIO SELECTIVITY (SEE FIG. 7-5 FOR . . . . .	82679	1	
		BREAKDOWN)			
-134	IM-149	. INSULATION SHEET . . . . .	82679	1	
-135	PX-333	. CAP, TERMINAL . . . . .	82679	2	
-136	44/AF	. LAMP, INCANDESCENT . . . . .	24456	2	
-137	44	. LAMP, INCANDESCENT . . . . .	24456	1	
-138	708	. LAMPHOLDER . . . . .	72619	2	
-139	PT-179	. LAMPHOLDER . . . . .	83345	1	
-140	12844	. CONNECTOR, RECEPTACLE . . . . .	71785	1	
	SCBS0440BN6	(ATTACHING PARTS)			
	LWE04MRN	. SCREW, MACHINE, 4-40 BY 3/8 IN. . . . .	82679	2	
	NTH0440BN6	. WASHER, LOCK, NO. 4 . . . . .	82679	2	
		. NUT, PLAIN, HEX, 4-40 BY 3/16 IN. . . . .	82679	2	
		---*---			
-141	312002	. FUSE, CARTRIDGE . . . . .	75915	1	
-142	HKP-M	. FUSEHOLDER . . . . .	03614	1	
-143	1774	. TERMINAL BOARD . . . . .	71785	1	
-144	1774	. TERMINAL BOARD . . . . .	71785	1	
	SCBS0440BN5	(ATTACHING PARTS)			
	LWE04MRN	. SCREW, MACHINE, 4-40 BY 5/16 IN. . . . .	82679	4	
	NTH0440BN8	. WASHER, LOCK, NO. 4 . . . . .	82679	4	
		. NUT, PLAIN, HEX, 4-40 BY 1/4 IN. . . . .	82679	4	
		---*---			
-145	16034	. CONNECTOR, RECEPTACLE . . . . .	71785	1	
	SCBS0440BN5	(ATTACHING PARTS)			
	LWE04MRN	. SCREW, MACHINE, 4-40 BY 5/16 IN. . . . .	82679	2	
	NTH0440BN8	. WASHER, LOCK, NO. 4 . . . . .	82679	2	
		. NUT, PLAIN, HEX, 4-40 BY 1/4 IN. . . . .	82679	2	
		---*---			
-146	UG-625/U	. CONNECTOR, RECEPTACLE . . . . .	71468	1	
-147	51B13405	. SOCKET, ELECTRON TUBE . . . . .	71785	2	
	SCBS0632BN5	(ATTACHING PARTS)			
	LWE06MRN	. SCREW, MACHINE, 6-32 BY 5/16 IN. . . . .	82679	4	
	NTH0632BN8	. WASHER, LOCK, NO. 6 . . . . .	82679	4	
		. NUT, PLAIN, HEX, 6-32 BY 1/4 IN. . . . .	82679	4	
		---*---			

FIGURE AND INDEX NUMBER	PART NUMBER	DESCRIPTION	VENDOR CODE	UNITS PER ASSY	US- ABLE ON CODE
		RADIO RECEIVER (CONT)			
7-2-148	8113	. CONNECTOR, RECEPTACLE . . . . .	71785	1	
		(ATTACHING PARTS)			
	SCBS0440BN5	. SCREW, MACHINE, 4-40 BY 5/16 IN. . . . .	82679	4	
	LWE04MRN	. WASHER, LOCK, NO. 4 . . . . .	82679	4	
	NTH0440BN6	. NUT, PLAIN, HEX, 4-40 BY 3/16 IN. . . . .	82679	4	
		---*---			
-149	SS-50	. SWITCH, SLIDE . . . . .	78488	2	
		(ATTACHING PARTS)			
	SCBS0440BN5	. SCREW, MACHINE, 4-40 BY 5/16 IN. . . . .	82679	4	
	LWE04MRN	. WASHER, LOCK, NO. 4 . . . . .	82679	4	
	NTH0440BN6	. NUT, PLAIN, HEX, 4-40 BY 3/16 IN. . . . .	82679	4	
		---*---			
-150	CT-104-3	. CAPACITOR, VARIABLE, AIR . . . . .	82679	1	
-151	L36AGD103PYV	. CAPACITOR, FIXED, CERAMIC . . . . .	01121	15	
-152	RG20GF682K	. RESISTOR, FIXED, COMPOSITION (MIL-R-11A) . . . . .		2	
-153	RC20GF684K	. RESISTOR, FIXED, COMPOSITION (MIL-R-11A) . . . . .		1	
-154	RC20GF274K	. RESISTOR, FIXED, COMPOSITION (MIL-R-11A) . . . . .		1	
-155	RC20GF220K	. RESISTOR, FIXED, COMPOSITION (MIL-R-11A) . . . . .		4	
-156	GP2K151	. CAPACITOR, FIXED, CERAMIC . . . . .	72982	1	
-157	RC20GF474K	. RESISTOR, FIXED, COMPOSITION (MIL-R-11A) . . . . .		2	
-158	RC20GF124K	. RESISTOR, FIXED, COMPOSITION (MIL-R-11A) . . . . .		3	
-159	RC20GF224K	. RESISTOR, FIXED, COMPOSITION (MIL-R-11A) . . . . .		1	
-160	RC20GF563K	. RESISTOR, FIXED, COMPOSITION (MIL-R-11A) . . . . .		1	
-161	BR-2025	. CAPACITOR, FIXED, ELECTROLYTIC . . . . .	14655	1	
-162	20F5000	. RESISTOR, FIXED, WIREWOUND . . . . .	63743	1	
		(ATTACHING PARTS)			
	SCFS0632BN40	. SCREW, MACHINE, 6-32 BY 2-1/2 IN. . . . .	82679	1	
	FW06HBN	. WASHER, FLAT, NO. 6 . . . . .	82679	1	
	LWE06MRN	. WASHER, LOCK, NO. 6 . . . . .	82679	1	
	WA-109-40	. WASHER . . . . .	82679	2	
	NTH0632BN10	. NUT, PLAIN, HEX, 6-32 BY 5/16 IN. . . . .	82679	1	
		---*---			
-163	RC42GF301K	. RESISTOR, FIXED, COMPOSITION (MIL-R-11A) . . . . .		1	
-164	RC20GF221K	. RESISTOR, FIXED, COMPOSITION (MIL-R-11A) . . . . .		4	
-165	RC20GF125K	. RESISTOR, FIXED, COMPOSITION (MIL-R-11A) . . . . .		2	
-166	811H1K35	. CAPACITOR, FIXED, CERAMIC . . . . .	72982	1	
	A-1092	. TERMINAL BOARD ASSY . . . . .	82679	1	
		(ATTACHING PARTS)			
-167	SCBS0632BN4	. SCREW, MACHINE, 6-32 BY 1/4 IN. . . . .	82679	2	
	LWE06MRN	. WASHER, LOCK, NO. 6 . . . . .	82679	2	
		---*---			
-168	RC20GF824K	. . . RESISTOR, FIXED, COMPOSITION (MIL-R-11A) . . . . .		1	
-169	RC20GF105K	. . . RESISTOR, FIXED, COMPOSITION (MIL-R-11A) . . . . .		1	
-170	RC20GF474K	. . . RESISTOR, FIXED, COMPOSITION (MIL-R-11A) . . . . .		1	
-171	GP2K221	. . . CAPACITOR, FIXED, CERAMIC . . . . .	72982	2	
-172	RC20GF473K	. . . RESISTOR, FIXED, COMPOSITION (MIL-R-11A) . . . . .		1	
-173	RC20GF224K	. . . RESISTOR, FIXED, COMPOSITION (MIL-R-11A) . . . . .		1	
-174	A-1045	. . . COIL, RADIO FREQUENCY . . . . .	82679	2	
-175	A-980	. . . TERMINAL BOARD . . . . .	82679	1	
-176	RC32GF682K	. RESISTOR, FIXED, COMPOSITION (MIL-R-11A) . . . . .		2	
-177	RC20GF472K	. RESISTOR, FIXED, COMPOSITION (MIL-R-11A) . . . . .		2	
-178	CC21SL510G	. CAPACITOR, FIXED, CERAMIC (JAN-C-20A) . . . . .		1	
-179	RC20GF334K	. RESISTOR, FIXED, COMPOSITION (MIL-R-11A) . . . . .		1	
-180	PJ455	. CAPACITOR, FIXED, PLASTIC . . . . .	14655	1	
-181	RC32GF4R7J	. RESISTOR, FIXED, COMPOSITION (MIL-R-11A) . . . . .		1	
-182	CC21SL150J	. CAPACITOR, FIXED, CERAMIC (JAN-C-20A) . . . . .		1	
-183	RC42GF333J	. RESISTOR, FIXED, COMPOSITION (MIL-R-11A) . . . . .		1	
-184	RC20GF123K	. RESISTOR, FIXED, COMPOSITION (MIL-R-11A) . . . . .		2	
-185	RC42GF682K	. RESISTOR, FIXED, COMPOSITION (MIL-R-11A) . . . . .		1	
-186	RC32GF563K	. RESISTOR, FIXED, COMPOSITION (MIL-R-11A) . . . . .		2	
-187	RC20GF104K	. RESISTOR, FIXED, COMPOSITION (MIL-R-11A) . . . . .		2	
-188	RC20GF105K	. RESISTOR, FIXED, COMPOSITION (MIL-R-11A) . . . . .		1	
-189	MS-634	. COVER . . . . .	82679	1	
		(ATTACHING PARTS)			
-190	SCBS0632BN5	. SCREW, MACHINE, 6-32 BY 5/16 IN. . . . .	82679	6	
		---*---			
-191	MS-650	. CHASSIS, ELECTRICAL EQUIPMENT . . . . .	82679	1	
-192	MS-625	. CHASSIS, ELECTRICAL EQUIPMENT . . . . .	82679	1	

FIGURE AND INDEX NUMBER	PART NUMBER	DESCRIPTION	VENDOR CODE	UNITS PER ASSY	US- ABLE ON CODE
		RADIO RECEIVER (CONT)			
7-2-193	MS-651	. CHASSIS, ELECTRICAL EQUIPMENT . . . . . (ATTACHING PARTS)	82679	1	
	SCFS0632BN5	. SCREW, MACHINE, 6-32 BY 5/16 IN. . . . .	82679	12	
	LWE06MRN	. WASHER, LOCK, NO. 6 . . . . .	82679	12	
	NTH0632BN8	. NUT, PLAIN, HEX, 6-32 BY 1/4 IN. . . . . ---*---	82679	12	
-194	56A	. TERMINAL BOARD . . . . . (ATTACHING PARTS)	71785	2	
	SCBS0632BN5	. SCREW, MACHINE, 6-32 BY 5/16 IN. . . . .	82679	4	
	LWE06MRN	. WASHER, LOCK, NO. 6 . . . . .	82679	4	
	NTH0632BN8	. NUT, PLAIN, HEX, 6-32 BY 1/4 IN. . . . . ---*---	82679	4	
-195	TYPE 46-461	. CAPACITOR, VARIABLE, MICA . . . . . (ATTACHING PARTS)	84171	2	
	SCBS0632BN5	. SCREW, MACHINE, 6-32 BY 5/16 IN. . . . .	82679	4	
	LWE06MRN	. WASHER, LOCK, NO. 6 . . . . .	82679	4	
	NTH0632BN8	. NUT, PLAIN, HEX, 6-32 BY 1/4 IN. . . . . ---*---	82679	4	
-196	A-892	. TRANSFORMER, RADIO FREQUENCY . . . . .	82679	1	
-197	A-897	. TRANSFORMER, RADIO FREQUENCY . . . . .	82679	1	
-198	A-905	. COIL, RADIO FREQUENCY . . . . .	82679	1	
-199	CC21SL470K	. . CAPACITOR, FIXED, CERAMIC (JAN-C-20A). . . . .		1	
-200	RC32GF153J	. . RESISTOR, FIXED, COMPOSITION (MIL-R-11A) . . . . .		1	
-201	A-898	. TRANSFORMER, RADIO FREQUENCY . . . . .	82679	1	
-202	A-901	. COIL, RADIO FREQUENCY . . . . .	82679	1	
-203	CC21SL050C	. . CAPACITOR, FIXED, CERAMIC (JAN-C-20A). . . . .		1	
-204	RC20GF472J	. . RESISTOR, FIXED, COMPOSITION (MIL-R-11A) . . . . .		1	
-205	A-900	. COIL, RADIO FREQUENCY . . . . .	82679	1	
-206	CC21SL050C	. . CAPACITOR, FIXED, CERAMIC (JAN-C-20A). . . . .		1	
-207	RC32GF223J	. . RESISTOR, FIXED, COMPOSITION (MIL-R-11A) . . . . .		1	
-208	A-961	. TRANSFORMER, RADIO FREQUENCY . . . . .	82679	1	
-209	CM20D162F	. . CAPACITOR, FIXED, MICA (MIL-C-5A). . . . .		1	
-210	A-962	. TRANSFORMER, RADIO FREQUENCY . . . . .	82679	1	
-211	CM15C271G	. . CAPACITOR, FIXED, MICA (MIL-C-5A). . . . .		1	
-212	A-966	. COIL, RADIO FREQUENCY . . . . .	82679	1	
-213	CC21SL220K	. . CAPACITOR, FIXED, CERAMIC (JAN-C-20A). . . . .		1	
-214	RC42GF153J	. . RESISTOR, FIXED, COMPOSITION (MIL-R-11A) . . . . .		1	
-215	A-963	. TRANSFORMER, RADIO FREQUENCY . . . . .	82679	1	
-216	A-964	. TRANSFORMER, RADIO FREQUENCY . . . . .	82679	1	
-217	RC20GF102K	. . RESISTOR, FIXED, COMPOSITION (MIL-R-11A) . . . . .		1	
-218	A-965	. COIL, RADIO FREQUENCY . . . . .	82679	1	
-219	CC21SL050C	. . CAPACITOR, FIXED, CERAMIC (JAN-C-20A). . . . .		1	
-220	RC42GF153J	. . RESISTOR, FIXED, COMPOSITION (MIL-R-11A) . . . . .		1	
-221	160-110	. CAPACITOR, VARIABLE, AIR . . . . .	74970	6	
-222	MS-635	. RETAINER . . . . . (ATTACHING PARTS)	82679	2	
	SCBS0632BN5	. SCREW, MACHINE, 6-32 BY 5/16 IN. . . . .	82679	4	
	LWE06MRN	. WASHER, LOCK, NO. 6 . . . . .	82679	4	
	NTH0632BN8	. NUT, PLAIN, HEX, 6-32 BY 1/4 IN. . . . . ---*---	82679	4	
-223	A-894	. COIL, RADIO FREQUENCY . . . . .	82679	1	
-224	CM20D431F	. . CAPACITOR, FIXED, MICA (MIL-C-5A). . . . .		1	
-225	A-896	. COIL, RADIO FREQUENCY . . . . .	82679	1	
-226	CM20D1091F	. . CAPACITOR, FIXED, MICA (MIL-C-5A). . . . .		1	
-227	A-1355	. COIL, RADIO FREQUENCY . . . . .	82679	1	
-228	CC45SH391J	. . CAPACITOR, FIXED, CERAMIC (JAN-C-20A). . . . .		1	
-229	CC45TH391J	. . CAPACITOR, FIXED, CERAMIC (JAN-C-20A). . . . .		1	
-230	A-899	. COIL, RADIO FREQUENCY . . . . .	82679	1	
-231	CC45UJ751J	. . CAPACITOR, FIXED, CERAMIC (JAN-C-20A). . . . .		2	
-232	CC35UJ181J	. . CAPACITOR, FIXED, CERAMIC (JAN-C-20A). . . . .		1	
-233	A-903	. COIL, RADIO FREQUENCY . . . . .	82679	1	
-234	CC35CG910J	. . CAPACITOR, FIXED, CERAMIC (JAN-C-20A). . . . .		1	
-235	CC45SH221J	. . CAPACITOR, FIXED, CERAMIC (JAN-C-20A). . . . .		1	
-236	A-1356	. COIL, RADIO FREQUENCY . . . . .	82679	1	
-237	CC45SH331J	. . CAPACITOR, FIXED, CERAMIC (JAN-C-20A). . . . .		1	
-238	CC32SH101J	. . CAPACITOR, FIXED, CERAMIC (JAN-C-20A). . . . .		1	
-239	L36AGD103PYV	. CAPACITOR, FIXED, CERAMIC . . . . .	01121	18	
-240	RC20GF221K	. RESISTOR, FIXED, COMPOSITION (MIL-R-11A) . . . . .		1	
-241	RC20GF390K	. RESISTOR, FIXED, COMPOSITION (MIL-R-11A) . . . . .		1	

FIGURE AND INDEX NUMBER	PART NUMBER	DESCRIPTION	VENDOR CODE	UNITS PER ASSY	US-ABLE ON CODE
RADIO RECEIVER (CONT)					
7-2-242	RC20GF220K	. RESISTOR, FIXED, COMPOSITION (MIL-R-11A) . . . . .		2	
-243	RC32GF472K	. RESISTOR, FIXED, COMPOSITION (MIL-R-11A) . . . . .		1	
-244	RC20GF563K	. RESISTOR, FIXED, COMPOSITION (MIL-R-11A) . . . . .		1	
-245	RC20GF331K	. RESISTOR, FIXED, COMPOSITION (MIL-R-11A) . . . . .		1	
-246	RC20GF272K	. RESISTOR, FIXED, COMPOSITION (MIL-R-11A) . . . . .		2	
-247	CC21UJ470J	. CAPACITOR, FIXED, CERAMIC (JAN-C-20A) . . . . .		2	
-248	RC20GF472K	. RESISTOR, FIXED, COMPOSITION (MIL-R-11A) . . . . .		1	
-249	RC20GF101J	. RESISTOR, FIXED, COMPOSITION (MIL-R-11A) . . . . .		1	
-250	RC20GF154K	. RESISTOR, FIXED, COMPOSITION (MIL-R-11A) . . . . .		1	
-251	RC20GF223K	. RESISTOR, FIXED, COMPOSITION (MIL-R-11A) . . . . .		2	
-252	CC20UJ4R7C	. CAPACITOR, FIXED, CERAMIC (JAN-C-20A) . . . . .		2	
-253	A-1045	. COIL, RADIO FREQUENCY . . . . .		1	
-254	CC21SL050C	. CAPACITOR, FIXED, CERAMIC (JAN-C-20A) . . . . .	82679	1	
-255	RC20GF100K	. RESISTOR, FIXED, COMPOSITION (MIL-R-11A) . . . . .		2	
-256	RC20GF104K	. RESISTOR, FIXED, COMPOSITION (MIL-R-11A) . . . . .		1	
-257	CC20RH4R7C	. CAPACITOR, FIXED, CERAMIC (JAN-C-20A) . . . . .		1	
-258	CC20UJ100J	. CAPACITOR, FIXED, CERAMIC (JAN-C-20A) . . . . .		1	
-259	CC20UJ6R8D	. CAPACITOR, FIXED, CERAMIC (JAN-C-20A) . . . . .		1	
-260	NI400A2R2	. CAPACITOR, FIXED, CERAMIC . . . . .	72982	2	
-261	RC20GF102J	. RESISTOR, FIXED, COMPOSITION (MIL-R-11A) . . . . .		1	
-262	CM20B102K	. CAPACITOR, FIXED, MICA (MIL-C-5A) . . . . .		1	
-263	1520A	. TERMINAL BOARD . . . . .	71785	4	
		(ATTACHING PARTS)			
	SCB0632BN4	. SCREW, MACHINE, 6-32 BY 1/4 IN. . . . .	82679	4	
	LWE06MRN	. WASHER, LOCK, NO. 6 . . . . .	82679	4	
	NTH0632BN8	. NUT, PLAIN, HEX, 6-32 BY 1/4 IN. . . . .	82679	4	
		---*---			
-264	PJ4S5	. CAPACITOR, FIXED, PLASTIC . . . . .	14655	1	
-265	RC42GF561K	. RESISTOR, FIXED, COMPOSITION (MIL-R-11A) . . . . .		1	
-266	L36AGD103PYV	. CAPACITOR, FIXED, CERAMIC . . . . .	01121	20	
-267	CC-100-23	. CAPACITOR, FIXED, CERAMIC . . . . .	82679	1	
-268	RC20GF103K	. RESISTOR, FIXED, COMPOSITION (MIL-R-11A) . . . . .		1	
-269	RC20GF470K	. RESISTOR, FIXED, COMPOSITION (MIL-R-11A) . . . . .		1	
-270	RC20GF151K	. RESISTOR, FIXED, COMPOSITION (MIL-R-11A) . . . . .		1	
-271	CL-108-6	. COIL, RADIO FREQUENCY . . . . .	82679	1	
-272	CR-103	. CRYSTAL UNIT . . . . .	82679	1	
-273	RC20GF511K	. RESISTOR, FIXED, COMPOSITION (MIL-R-11A) . . . . .		1	
-274	RC20GF104K	. RESISTOR, FIXED, COMPOSITION (MIL-R-11A) . . . . .		2	
-275	A-989	. TRANSFORMER . . . . .	82679	1	
-276	RC20GF221K	. RESISTOR, FIXED, COMPOSITION (MIL-R-11A) . . . . .		1	
-277	CC21SL470K	. CAPACITOR, FIXED, CERAMIC (JAN-C-20A) . . . . .		1	
-278	RC32GF563K	. RESISTOR, FIXED, COMPOSITION (MIL-R-11A) . . . . .		1	
	A-1347	. TERMINAL BOARD ASSY . . . . .	82679	1	
		(ATTACHING PARTS)			
	SCBS0632BN4	. SCREW, MACHINE, 6-32 BY 1/4 IN. . . . .	82679	2	
	LWE06MRN	. WASHER, LOCK, NO. 6 . . . . .	82679	2	
		---*---			
-279	CM15E151G	. CAPACITOR, FIXED, MICA (MIL-C-5A) . . . . .		2	
-280	CM15E560G	. CAPACITOR, FIXED, MICA (MIL-C-5A) . . . . .		2	
-281	CM15E111G	. CAPACITOR, FIXED, MICA (MIL-C-5A) . . . . .		1	
-282	A-1076	. COIL, RADIO FREQUENCY . . . . .	82679	2	
-283	A-1077	. COIL, RADIO FREQUENCY . . . . .	82679	1	
-284	A-1345	. COIL, RADIO FREQUENCY . . . . .	82679	3	
-285	A-1346	. TERMINAL BOARD . . . . .	82679	1	
-286	CM15E111G	. CAPACITOR, FIXED, MICA (MIL-C-5A) . . . . .		1	
-287	RC20GF825K	. RESISTOR, FIXED, COMPOSITION (MIL-R-11A) . . . . .		1	
-288	RC20GF100K	. RESISTOR, FIXED, COMPOSITION (MIL-R-11A) . . . . .		1	
-289	CE-100	. CAPACITOR, FIXED, ELECTROLYTIC . . . . .	82679	1	
-290	CC21SL080G	. CAPACITOR, FIXED, CERAMIC (JAN-C-20A) . . . . .		1	
-291	TR-116	. TRANSFORMER, RADIO FREQUENCY . . . . .	82679	1	
		(ATTACHING PARTS)			
	SCBS0632BN5	. SCREW, MACHINE, 6-32 BY 5/16 IN. . . . .	82679	1	
	LWE06MRN	. WASHER, LOCK, NO. 6 . . . . .	82679	1	
	NTH0632BN8	. NUT, PLAIN, HEX, 6-32 BY 1/4 IN. . . . .	82679	1	
		---*---			
-292	RC42GF223J	. RESISTOR, FIXED, COMPOSITION (MIL-R-11A) . . . . .		1	
-293	1540A	. TERMINAL BOARD . . . . .	71785	2	
-294	1513A	. TERMINAL BOARD . . . . .	71785	2	
-295	1520A	. TERMINAL BOARD . . . . .	71785	4	

FIGURE AND INDEX NUMBER	PART NUMBER	DESCRIPTION	VENDOR CODE	UNITS PER ASSY	US-ABLE ON CODE
RADIO RECEIVER (CONT)					
7-2-296	1520	. TERMINAL BOARD . . . . . (ATTACHING PARTS)	71785	1	
	SCBS0632BN4	. SCREW, MACHINE, 6-32 BY 1/4 IN. . . . .	82679	11	
	LWE06MRN	. WASHER, LOCK, NO. 6 . . . . .	82679	11	
	NTH0632BN8	. NUT, PLAIN, HEX, 6-32 BY 1/4 IN. . . . . -----*	82679	11	
-297	PM-416	. INERTIA WHEEL . . . . . (ATTACHING PARTS)	82679	2	
	AN565D6H3	. SETSCREW . . . . . -----*		4	
-298	A-985-1	. PLATE, MOUNTING . . . . .	82679	1	
-299	A-985-2	. PLATE, MOUNTING . . . . . (ATTACHING PARTS)	82679	1	
	SCFS0832BN28	. SCREW, MACHINE, 8-32 BY 1-3/4 IN. . . . .	82679	8	
	LWE08MRN	. WASHER, LOCK, NO. 8 . . . . .	82679	8	
	NTH0832BN10	. NUT, PLAIN, HEX, 8-32 BY 5/16 IN. . . . . -----*	82679	8	
-300	TE-148	. SPACER, SLEEVE . . . . .	82679	8	
-301	A-1470	. SWITCH, ROTARY . . . . .	82679	1	
-302	FNC-46-S	. COUPLING, SHAFT . . . . . (ATTACHING PARTS)	80583	1	
	AN565D6H3	. SETSCREW . . . . . -----*		4	
-303	SP-117	. SPRING, HELICAL . . . . . (ATTACHING PARTS)	82679	1	
	SCBS1032BN6	. SCREW, MACHINE, 10-32 BY 3/8 IN. . . . .	82679	1	
	LWE10MRN	. WASHER, LOCK, NO. 10 . . . . . -----*	82679	1	
-304	DT-100	. LOCK, SHAFT . . . . . (ATTACHING PARTS)	82679	1	
	SCFS0632BN38	. SCREW, MACHINE, 6-32 BY 2-3/8 IN. . . . .	82679	6	
	LW106MRN	. WASHER, LOCK, NO. 6 . . . . .	82679	6	
	NTH0632BN8	. NUT, PLAIN, HEX, 6-32 BY 1/4 IN. . . . . -----*	82679	6	
-305	A-984	. PLATE, MOUNTING . . . . .	82679	1	
-306	MS-638	. SIDE PLATE, RIGHT . . . . .	82679	1	
-307	MS-637	. SIDE PLATE, LEFT . . . . . (ATTACHING PARTS)	82679	1	
	SCFS0632BN6	. SCREW, MACHINE, 6-32 BY 3/8 IN. . . . .	82679	16	
	2WE06MRN	. WASHER, LOCK, NO. 6 . . . . .	82679	16	
	NTH0632BN10	. NUT, PLAIN, HEX, 6-32 BY 5/16 IN. . . . . -----*	82679	16	
-308	MS-608	. CHASSIS, ELECTRICAL EQUIPMENT . . . . .	82679	1	
CRYSTAL ASSEMBLY					
7-3-	A-1037	CRYSTAL ASSY (SEE FIG. 7-2-105 FOR NEXT HIGHER . . . . . ASSEMBLY)	82679	REF	
-1	C8091-632-67	. NUT, SHEET SPRING . . . . .	89032	1	
-2	CR-102	. CRYSTAL UNIT . . . . .	82679	1	
-3	CM15C030M	. CAPACITOR, FIXED, MICA (MIL-C-5A). . . . .		1	
-4	CT-105-1	. CAPACITOR, VARIABLE, AIR . . . . . (ATTACHING PARTS)	82679	1	
	SCBS0632BN5	. SCREW, MACHINE, 6-32 BY 5/16 IN. . . . .	82679	2	
	LWE06MRN	. WASHER, LOCK, NO. 6 . . . . . -----*	82679	2	
-5	IM-167	. INSULATOR . . . . .	82679	1	
-6	CM20D301G	. CAPACITOR, FIXED, MICA (MIL-C-5A). . . . .		1	
-7	RC20GF100J	. RESISTOR, FIXED, COMPOSITION (MIL-R-11A) . . . . .		2	
-8	RC20GF220J	. RESISTOR, FIXED, COMPOSITION (MIL-R-11A) . . . . .		1	
-9	RC20GF101J	. RESISTOR, FIXED, COMPOSITION (MIL-R-11A) . . . . .		1	
-10	TE-111-2	. TERMINAL, LUG . . . . .	82679	1	
-11	SW-147	. SWITCH, ROTARY . . . . . (ATTACHING PARTS)	82679	1	
	NTH3732BN16	. NUT, PLAIN, HEX, 3/8-32 BY 1/2 IN. . . . .	82679	1	
	LW137LRN	. WASHER, LOCK, 3/8 IN. . . . . -----*	82679	1	

FIGURE AND INDEX NUMBER	PART NUMBER	DESCRIPTION							VENDOR CODE	UNITS PER ASSY	US-ABLE ON CODE
		1	2	3	4	5	6	7			
		CRYSTAL ASSEMBLY (CONT)									
7-3-12	A-944	. COIL, RADIO FREQUENCY . . . . .							82679	1	
		(ATTACHING PARTS)									
	NT-102	. NUT, PLAIN, HEX . . . . .							82679	1	
	LW125LRN	. WASHER, LOCK, 1/4 IN. . . . .							82679	1	
	SP-102	. WASHER, SPRING . . . . .							82679	1	
		----*----									
-13	A-976	. TERMINAL BOARD . . . . .							82679	1	
		(ATTACHING PARTS)									
	SCBS0632BN5	. SCREW, MACHINE, 6-32 BY 5/16 IN. . . . .							82679	2	
	LWE06MRN	. WASHER, LOCK, NO. 6 . . . . .							82679	2	
		----*----									
-14	MS-587	. CAN, CRYSTAL . . . . .							82679	1	

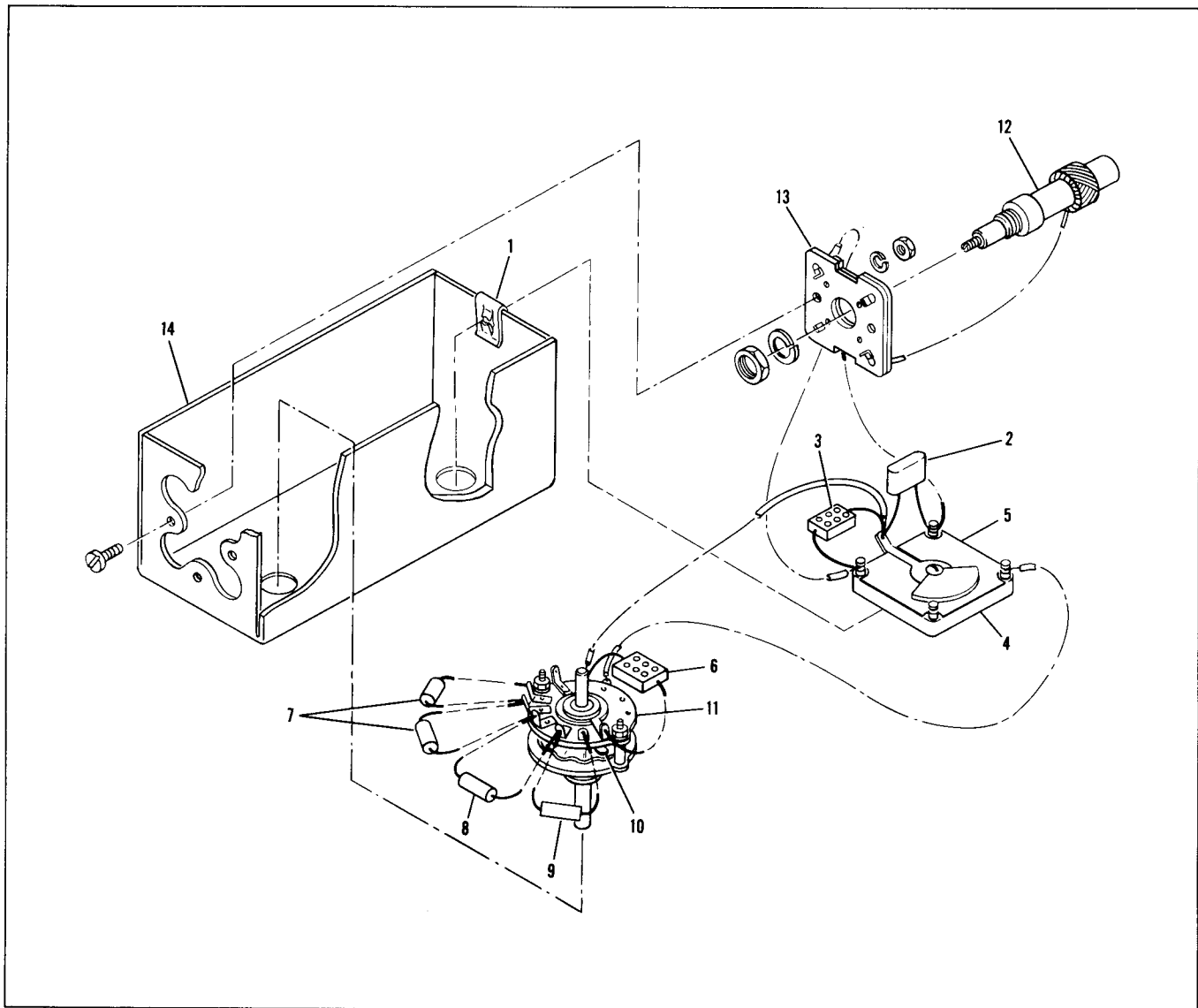

FIGURE 7-3. CRYSTAL ASSEMBLY

FIGURE AND INDEX NUMBER	PART NUMBER	DESCRIPTION	VENDOR CODE	UNITS PER ASSY	US-ABLE ON CODE
		RADIO FREQUENCY COIL			
7-4-	A-1043	COIL, RADIO FREQUENCY (SEE FIG. 7-2-132 FOR NEXT . . . . . HIGHER ASSEMBLY)	82679	REF	
-1	A-907	. CAN ASSY . . . . . (ATTACHING PARTS)	82679	1	
	SCBS0632BN4	. SCREW, MACHINE, 6-32 BY 1/4 IN. . . . .	82679	1	
	LW106MRN	. WASHER, LOCK, NO. 6 . . . . .	82679	1	
-2	CT-104-4	. CAPACITOR, VARIABLE, AIR . . . . . (ATTACHING PARTS)	82679	1	
	SCFS0440BN4	. SCREW, MACHINE, 4-40 BY 1/4 IN. . . . .	82679	2	
-3	MS-591	. BRACKET, ANGLE . . . . . (ATTACHING PARTS)	82679	1	
	SCBS0632BN6	. SCREW, MACHINE, 6-32 BY 3/8 IN. . . . .	82679	2	
	LW106MRN	. WASHER, LOCK, NO. 6 . . . . .	82679	2	
	NTH0632B48	. NUT, PLAIN, HEX, 6-32 BY 1/4 IN. . . . .	82679	2	
-4	TE-149-144	. TERMINAL, LUG . . . . .	82679	1	
-5	CM20D152G	. CAPACITOR, FIXED, MICA (MIL-C-5A) . . . . .		1	
-6	GP2K221	. CAPACITOR, FIXED, CERAMIC . . . . .	72982	1	
-7	RC20GF473K	. RESISTOR, FIXED, COMPOSITION . . . . .	82679	1	
-8	CI-109-11	. COIL, RADIO FREQUENCY . . . . . (ATTACHING PARTS)	82679	1	
	NT-102	. NUT, PLAIN, HEX . . . . .	82679	1	
	LW125LRC	. WASHER, LOCK, 1/4 IN. . . . .	82679	1	
	SP-102	. WASHER, SPRING . . . . .	82679	1	
	SM-110	. BUSHING . . . . .	82679	1	
-9	A-908	. TERMINAL BOARD . . . . .	82679	1	

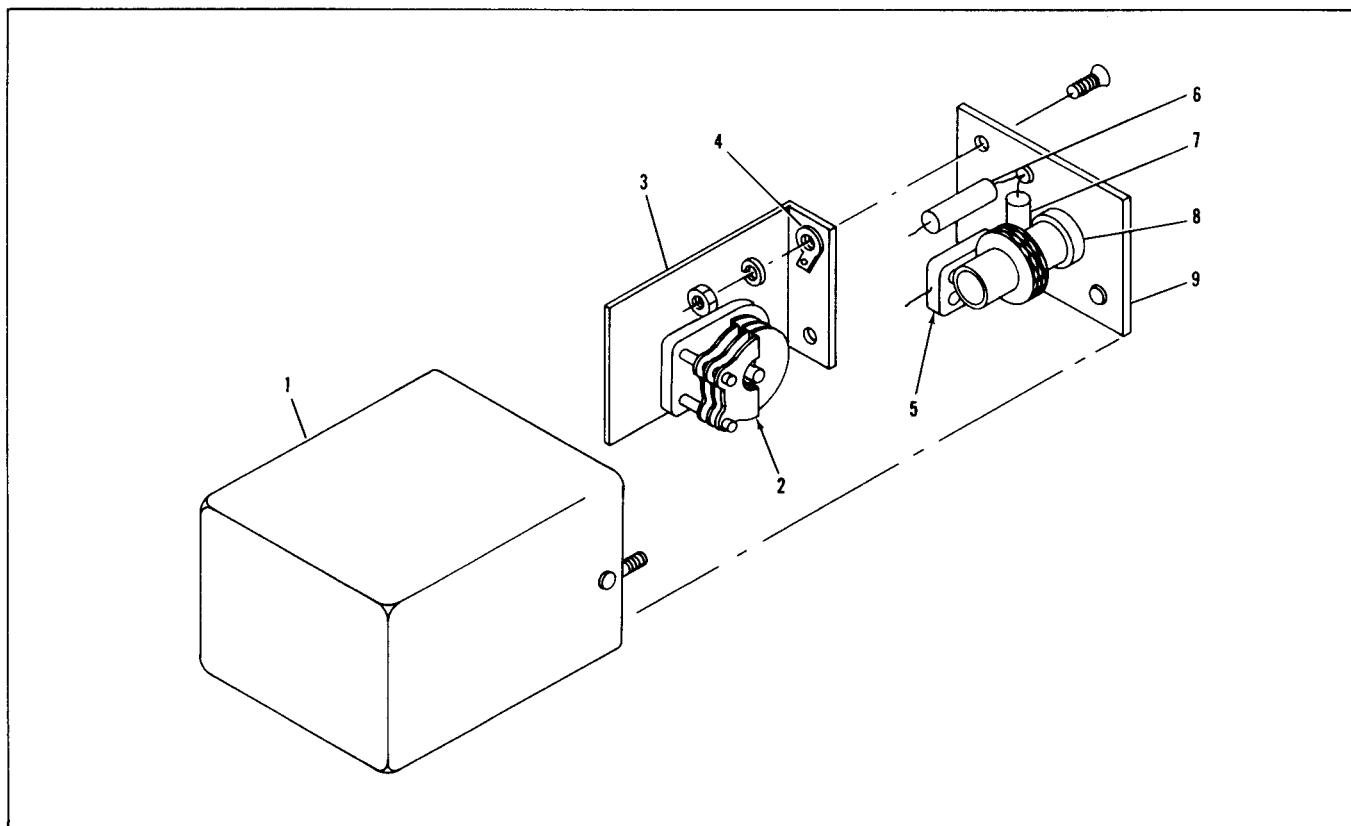

FIGURE 7-4. RADIO FREQUENCY COIL

FIGURE AND INDEX NUMBER	PART NUMBER	DESCRIPTION							VENDOR CODE	UNITS PER ASSY	US-ABLE ON CODE
		1	2	3	4	5	6	7			
		AUDIO SELECTIVITY NETWORK ASSEMBLY									
7-5-	A-924	NETWORK ASSY, AUDIO SELECTIVITY (SEE FIG. 7-2-133 FOR . . .							82679	REF	
-1	BX-142	NEXT HIGHER ASSEMBLY)									
		. DUST COVER . . . . .							82679	1	
		(ATTACHING PARTS)									
-2	NTH0632BN8	. NUT, PLAIN, HEX, 6-32 BY 1/4 IN. . . . .							82679	1	
-3	LWE06MRN	. WASHER, LOCK, NO. 6 . . . . .							82679	1	
		----*									
-4	6390	. REACTOR . . . . .							88063	1	
		(ATTACHING PARTS)									
-5	SCFS0632BN24	. SCREW, MACHINE, 6-32 BY 1-1/2 IN. . . . .							82679	1	
-6	LWE06MRN	. WASHER, LOCK, NO. 6 . . . . .							82679	2	
-7	FW-100-2AL	. WASHER, FLAT . . . . .							82679	2	
-8	WA-109-38	. WASHER, NONMETALLIC . . . . .							82679	1	
-9	GA-137-3	. GASKET . . . . .							82679	1	
-10	NTH0632BN8	. NUT, PLAIN, HEX, 6-32 BY 1/4 IN. . . . .							82679	2	
		----*									
-11	RC32GF223J	. RESISTOR, FIXED, COMPOSITION (MIL-R-11A) . . . . .								1	
-12	811H1K35	. CAPACITOR, FIXED, CERAMIC . . . . .							72982	1	
-13	817H1K70	. CAPACITOR, FIXED, CERAMIC . . . . .							72982	1	
-14	PX-270	. INSULATOR . . . . .							82679	1	
-15	SW-156	. SWITCH, ROTARY . . . . .							82679	1	

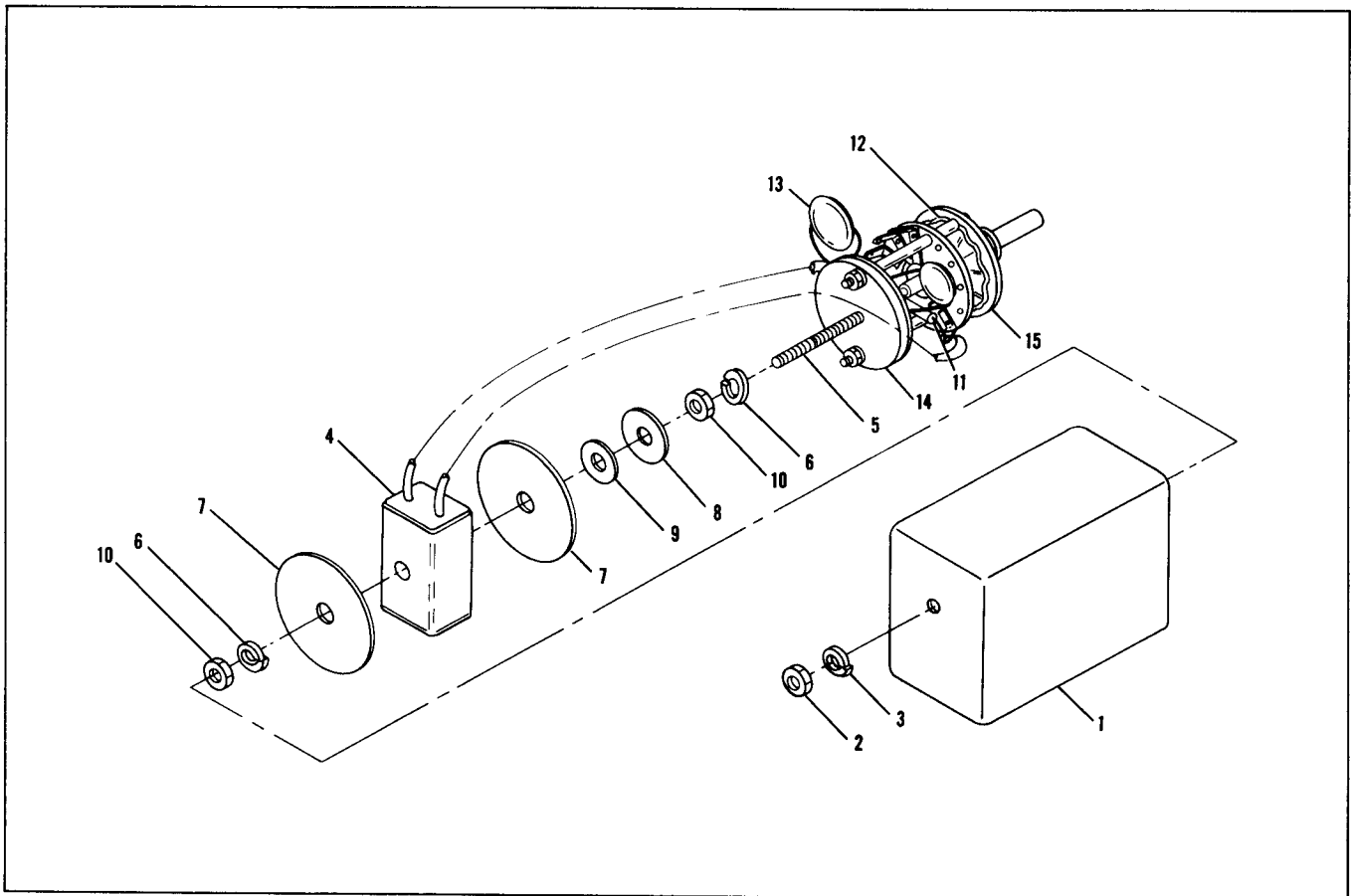

FIGURE 7-5. AUDIO SELECTIVITY NETWORK ASSEMBLY

SECTION 8  
NUMERICAL INDEX

PART NUMBER	STOCK NUMBER		FIGURE & INDEX NUMBER	QTY PER ART.	SO-SOURCE CODE	PART NUMBER	STOCK NUMBER		FIGURE & INDEX NUMBER	QTY PER ART.	SO-SOURCE CODE
	CLASS CODE	SERIAL OR PART NUMBER					CLASS CODE	SERIAL OR PART NUMBER			
A-1024-1			7-2-26	1		CB-130	5910-296-4987	7-2-117	1		
A-1024-3			7-2-27	1		CB-131	5910-607-2805	7-2-116	1		
A-1025			7-2-104	1		CC-100-23		7-2-267	1		
A-1034	5950-578-8552		7-2-103	1		CC20RH4R7C		7-2-257	1		
A-1037			7-2-105	1		CC20UJ100J	5910-129-9199	7-2-258	1		
			7-3-	REF		CC20UJ4R7C		7-2-252	2		
A-1038			7-2-102	1		CC20UJ6R8D		7-2-259	1		
A-1039-1-2			7-2-99	2		CC21SL050C	5910-197-1559	7-2-206	4		
A-1039-3			7-2-100	1				7-2-203			
A-1040			7-2-95	1				7-2-219			
A-1041	5950-647-9510		7-2-73	1				7-2-254			
A-1043	5950-647-9154		7-2-132	1		CC21SL080G		7-2-290	1		
			7-4-	REF		CC21SL150J	5910-245-4645	7-2-182	1		
A-1045	5950-578-8004		7-2-174	3		CC21SL220K	5910-112-8589	7-2-213	1		
			7-2-253			CC21SL470K	5910-112-8209	7-2-55	3		
A-1076	5950-578-8003		7-2-282	2				7-2-199			
A-1077	5950-578-8007		7-2-283	1				7-2-277			
A-1092			7-2-167	1		CC21UJ470J	5910-668-0188	7-2-247	2		
A-1345	5950-578-8002		7-2-284	3		CC21SL510G		7-2-178	1		
A-1346			7-2-285	1		CC26CH300J		7-2-121	1		
A-1347			7-2-278	1		CC32SH101J		7-2-238	1		
A-1355			7-2-227	1		CC35CG910J	5910-112-7981	7-2-234	1		
A-1356			7-2-236	1		CC35UJ181J	5910-112-8380	7-2-232	1		
A-1470			7-2-301	1		CC45SH221J		7-2-235	1		
A-892	5950-606-3732		7-2-196	1		CC45SH331J		7-2-237	1		
A-894	5950-578-1995		7-2-223	1		CC45SH391J	5910-519-4374	7-2-228	1		
A-896	5950-578-8265		7-2-225	1		CC45TH391J	5910-643-8994	7-2-229	1		
A-897	5950-578-1998		7-2-197	1		CC45UJ751J	5910-688-0240	7-2-231	2		
A-898	5950-578-1801		7-2-201	1		CE-100		7-2-289	1		
A-899	5950-568-5000		7-2-230	1		CI-109-11		7-4-8	1		
A-900	5950-608-2146		7-2-205	1		CL-100-5		7-2-49	1		
A-901	5950-578-5028		7-2-202	1		CL-108-6	5950-644-5646	7-2-271	1		
A-903	5950-578-8026		7-2-233	1		CM15C030M		7-3-3	1		
A-905	5950-578-1997		7-2-198	1		CM15C271G	5910-668-0610	7-2-211	1		
A-907			7-4-1	1		CM15E111G	5910-666-8879	7-2-281	2		
A-908			7-4-9	1				7-2-286			
A-924			7-2-133	1		CM15E151G	5910-636-2110	7-2-279	2		
			7-5-	REF		CM15E560G	5910-254-5991	7-2-280	2		
A-944			7-3-12	1		CM20B102K	5910-581-2159	7-2-262	1		
A-961	5950-547-8545		7-2-208	1		CM20D152G	5910-264-9443	7-4-5	1		
A-962	5950-578-1802		7-2-210	1		CM20D162F		7-2-209	1		
A-963	5950-578-1994		7-2-215	1		CM20D301G	5910-191-0910	7-3-6	1		
A-964	5950-578-1996		7-2-216	1		CM20D431F	5910-191-1844	7-2-224	1		
A-965	5950-607-2806		7-2-218	1		CM20D1091F		7-2-226	1		
A-966	5950-607-2807		7-2-212	1		CR-100		7-2-129	1		
A-976			7-3-13	1		CR-102		7-3-2	1		
A-980			7-2-175	1		CR-103		7-2-272	1		
A-983			7-2-110	1		CR-18/U		7-2-40	10		
A-984			7-2-305	1		CT-104-1		7-2-43	1		
A-985-1			7-2-298	1		CT-104-3	5910-557-5297	7-2-150	1		
A-985-2			7-2-299	1		CT-104-4		7-4-2	1		
A-989			7-2-275	1		CT-104-5		7-2-107	1		
AN565D4H2			7-2-120	2		CT-105-1		7-3-4	1		
AN565D6H3			7-2-66	13		CU-106		7-2-130	1		
			7-2-113			GP2K221		7-4-6	1		
			7-2-297			C6227-632-67		7-2-33	3		
			7-2-302			C8091-632-67		7-2-3	6		
BR-2025			7-2-161	1				7-3-1			
BX-142			7-5-1	1		DT-100		7-2-304	1		

CE-130  
August 1961

PART NUMBER	STOCK NUMBER		FIGURE & INDEX NUMBER	QTY PER ART.	SO-SOURCE CODE	PART NUMBER	STOCK NUMBER		FIGURE & INDEX NUMBER	QTY PER ART.	SO-SOURCE CODE
	CLASS CODE	SERIAL OR PART NUMBER					CLASS CODE	SERIAL OR PART NUMBER			
FNC-46-5			7-2-302	1		LWE06MRN (CONT)			7-2-296		
FS-102-1			7-2-61	1					7-3-4		
FW-100-2AL			7-5-7	2					7-3-13		
FW02HBN			7-2-33	3					7-5-3		
FW04HBN			7-2-25	14					7-5-6		
			7-2-42			LWE08MRN			7-2-72	18	
			7-2-67						7-2-126		
			7-2-68						7-2-299		
			7-2-123			LWE10MRN			7-2-105	2	
FW06HBN			7-2-124			LWI06MRN			7-2-1	19	
			7-2-17	5					7-2-2		
			7-2-115						7-2-304		
			7-2-162						7-4-1		
GA-137-3			7-5-9	1					7-4-3		
GB-2252			7-2-69	1		LWI25LRC			7-4-8	1	
GPR-90			7-1-	REF		LWI25LRN			7-3-12	1	
			7-2-	1		LWI37LRN			7-3-11	1	
GPR-90RX			7-1-	REF		LWS02MRN			7-2-33	3	
			7-2-	1		LWS03MRN			7-2-37	2	
GP2K151	5910-667-8885		7-2-156	1		LWS04MRN			7-2-41	40	
GP2K221	5910-648-9291		7-2-171	2					7-2-59		
GR-122			7-2-28	2					7-2-91		
GR-123			7-2-30	2		LWS06MRN			7-2-12	6	
HKP-M			7-2-142	1		L36AGDL03PYV			7-2-48	56	
IM-149			7-2-134	1					7-2-151		
IM-167			7-3-5	1					7-2-239		
K-10094-2			7-2-16	2					7-2-266		
K-33102			7-2-131	1		MP-108-2			7-2-4	6	
KJ4-45X247			7-2-35	1		MP-109-1			7-2-9	1	
LWE10MRN			7-2-303	1		MP-109-2			7-2-14	3	
LWE04MRN			7-2-25	39					7-2-39		
			7-2-42			MR-107	6625-696-5548		7-2-33	1	
			7-2-56			MS-1127			7-2-38	1	
			7-2-62			MS-1128			7-2-72	1	
			7-2-67			MS-1130			7-2-71	1	
			7-2-68			MS-1131			7-2-3	1	
			7-2-70			MS-1132			7-2-42	1	
			7-2-71			MS-1133			7-2-123	1	
			7-2-107			MS-1136			7-2-109	1	
			7-2-131			MS-1140			7-2-1	1	
			7-2-140			MS-584			7-2-108	1	
			7-2-144			MS-587			7-3-14	1	
			7-2-145			MS-591			7-4-3	1	
			7-2-148			MS-593			7-2-96	2	
			7-2-149						7-2-115		
LWE06MRN			7-2-17	160		MS-607			7-2-72	1	
			7-2-73			MS-608			7-2-308	1	
			7-2-94			MS-618			7-2-109	1	
			7-2-95			MS-623			7-2-24	1	
			7-2-96			MS-624			7-2-97	1	
			7-2-97			MS-625			7-2-192	1	
			7-2-98			MS-631			7-2-12	2	
			7-2-100			MS-634			7-2-189	1	
			7-2-103			MS-635			7-2-222	2	
			7-2-104			MS-637			7-2-307	1	
			7-2-105			MS-638			7-2-306	1	
			7-2-108			MS-639			7-2-1	1	
			7-2-110			MS-640			7-2-2	1	
			7-2-111			MS-650			7-2-191	1	
			7-2-115			MS-651			7-2-193	1	
			7-2-117			NT-102			7-2-12	2	
			7-2-118						7-4-8		
			7-2-125			NP-136			7-2-23	1	
			7-2-127			NP-196-1			7-2-22	1	
			7-2-128			NP-205			7-2-34	1	
			7-2-132			NT-104-1			7-2-109	6	
			7-2-147			NTH0256BN6			7-2-33	3	
			7-2-162			NTH0348BN6			7-2-37	2	
			7-2-167			NTH0440BN6			7-2-41	52	
			7-2-193						7-2-59		
			7-2-194						7-2-91		
			7-2-195						7-2-131		
			7-2-222						7-2-140		
			7-2-263						7-2-148		
			7-2-278						7-2-149		
			7-2-291			NTH0440BN8			7-2-25	24	

PART NUMBER	STOCK NUMBER		FIGURE & INDEX NUMBER	QTY PER ART.	SO-SOURCE CODE	PART NUMBER	STOCK NUMBER		FIGURE & INDEX NUMBER	QTY PER ART.	SO-SOURCE CODE
	CLASS CODE	SERIAL OR PART NUMBER					CLASS CODE	SERIAL OR PART NUMBER			
NTH0440BN8 (CONT)			7-2-42			RC20GF102K	5905-195-6806	7-2-51	2		
			7-2-56			RC20GF103K	5905-185-8510	7-2-217			
			7-2-62			RC20GF104K	5905-195-6761	7-2-268	1		
			7-2-67					7-2-187	5		
			7-2-68					7-2-256			
			7-2-71					7-2-274			
			7-2-144			RC20GF105K	5905-279-2513	7-2-169	2		
			7-2-145					7-2-188			
NTH0632BN10			7-2-162	17				7-1-53	1		
			7-2-307			RC20GF121K		7-2-184	2		
NTH0632BN8			7-2-17	133		RC20GF123K	5905-279-3502	7-2-158	3		
			7-2-73			RC20GF124K	5905-192-3981	7-2-165	1		
			7-2-94			RC20GF125K	5905-190-8874	7-2-270	1		
			7-2-95			RC20GF151K		7-2-270	1		
			7-2-96			RC20GF154K	5905-279-2522	7-2-250	1		
			7-2-97			RC20GF220J	5905-279-3519	7-3-8	1		
			7-2-100			RC20GF220K	5905-279-3519	7-2-155	6		
			7-2-103					7-2-242			
			7-2-104			RC20GF221K	5905-279-3513	7-2-164	6		
			7-2-108					7-2-240			
			7-2-110					7-2-276			
			7-2-111			RC20GF223K	5905-171-2004	7-2-50	3		
			7-2-115					7-2-251			
			7-2-118			RC20GF224K	5905-192-0667	7-2-159	2		
			7-2-125					7-2-173			
			7-2-127			RC20GF272K	5905-279-3499	7-2-246	2		
			7-2-128			RC20GF274K	5905-190-8865	7-2-154	1		
			7-2-132			RC20GF331K	5905-192-3971	7-2-245	1		
			7-2-147			RC20GF334K	5905-279-2519	7-2-179	1		
			7-2-193			RC20GF390K	5905-195-5546	7-2-241	1		
			7-2-194			RC20GF470K	5905-252-4018	7-1-54	2		
			7-2-195					7-2-269			
			7-2-222			RC20GF472J	5905-279-3504	7-2-204	1		
			7-2-263			RC20GF472K	5905-279-3504	7-2-177	3		
			7-2-291					7-2-248			
			7-2-296			RC20GF473K	5905-254-9201	7-2-52	3		
			7-2-304					7-2-172			
			7-4-3					7-4-7			
			7-5-2			RC20GF474K	5905-279-2515	7-2-157	3		
			7-5-10					7-2-170			
NTH0832BN10			7-2-72	18		RC20GF511K		7-2-273	1		
			7-2-126			RC20GF563K	5905-171-1986	7-2-160	2		
			7-2-299					7-2-244			
NTH3732BN16			7-3-11	1		RC20GF682K	5905-279-3503	7-2-152	2		
N1400A2R2			7-2-260	2		RC20GF684K	5905-171-2000	7-2-153	1		
PJ4S5			7-2-180	2		RC20GF824K	5905-221-5848	7-2-168	1		
			7-2-264			RC20GF825K	5905-279-1888	7-2-827	1		
PM-224			7-2-18	2		RC32GF153J	5905-299-2028	7-2-200	1		
PM-225			7-2-19	2		RC32GF223J	5905-299-2022	7-2-207	2		
PM-325			7-2-31	2				7-5-11			
PM-326			7-2-32	2		RC32GF223K	5905-284-2776	7-1-47	1		
PM-338			7-2-16	2		RC32GF4R7J	5905-101-7586	7-2-181	1		
PM-341			7-2-17	2		RC32GF472K	5905-299-2040	7-2-243	1		
PM-416			7-2-297	2		RC32GF563K	5905-299-2011	7-2-186	3		
PM-460-5.00BN			7-2-65	1				7-2-278			
PM-461			7-2-120	1		RC32GF682K	5905-299-2036	7-2-176	2		
PM-462			7-2-67	1		RC42GF153J	5905-171-1976	7-2-214	2		
PM-463			7-2-66	1				7-2-220			
PM-496			7-2-118	4		RC42GF223J	5905-279-2527	7-2-292	1		
PN-108			7-2-63	1		RC42GF301K		7-2-163	1		
PN-111			7-2-38	2		RC42GF333J	5905-279-2675	7-2-183	1		
PN-112			7-2-64	1		RC42GF561K		7-2-265	1		
PT-179			7-2-139	1		RC42GF680K		7-1-46	1		
PX-264			7-2-25	2		RC42GF682K	5905-279-2528	7-2-185	1		
PX-270			7-5-14	1		RV4ATRD105D		7-1-6	1		
PX-284			7-2-114	1		RV4ATSA103B		7-1-106	1		
PX-333			7-2-135	2		RV4ATSC152B		7-1-10	1		
PX-413			7-2-119	2		RV4BTRD502E	5905-578-4129	7-1-5	1		
RA101ASSA251A			7-2-101	1		S-311-64-BB-DD-L		7-2-13	1		
RC20GF100J	5905-190-8883		7-3-7	2		SC-106-1		7-2-111	6		
RC20GF100K	5905-190-8883		7-2-255	3		SCBS0440BN10		7-2-131	2		
			7-2-288			SCBS0440BN3		7-2-70	3		
RC20GF101J	5905-190-8889		7-2-249	2				7-2-107			
			7-3-9			SCBS0440BN4		7-2-56	9		
RC20GF102J	5905-195-6806		7-2-261	1				7-2-62			

CE-130  
August 1961

PART NUMBER	STOCK NUMBER		FIGURE & INDEX NUMBER	QTY PER ART.	SO-SOURCE CODE	PART NUMBER	STOCK NUMBER		FIGURE & INDEX NUMBER	QTY PER ART.	SO-SOURCE CODE
	CLASS CODE	SERIAL OR PART NUMBER					CLASS CODE	SERIAL OR PART NUMBER			
SCBS0440BN4 (CONT)			7-2-67			SW-156	5930-578-2321	7-5-15	1		
			7-2-68			SW-203		7-2-122	1		
			7-2-123			SW-222		7-2-45	1		
SCBS0440BN5			7-2-124	44		S4-200		7-2-37	1		
			7-2-59			T-110-62		7-2-20	5		
			7-2-91			TE-111-1		7-2-7	2		
			7-2-144			TE-111-2		7-3-10	1		
			7-2-145			TE-116-1		7-2-44	1		
			7-2-148			TE-117-11		7-2-112	6		
			7-2-149			TE-135-5		7-2-98	2		
SCBS0440BN6			7-2-140	2		TE-148		7-2-300	8		
SCBS0440BN8			7-2-41	10		TE-149-120		7-2-62	1		
SCBS0632BN10			7-2-118	4		TE-149-144		7-2-21	2		
SCBS0632BN12			7-2-96	2				7-4-4			
SCBS0632BN4			7-2-108	24		TF-159	5950-578-8267	7-2-125	1		
			7-2-128			TF-169		7-2-126	1		
			7-2-167			TR-116	5950-578-8553	7-2-291	1		
			7-2-263			TS102C01	5932-232-3758	7-2-91	1		
			7-2-278			TS102P01	5935-260-0516	7-2-59	13		
			7-2-296					7-2-89			
SCBS0632BN5			7-4-1			TS102U01		7-2-75	1		
			7-2-1	79		TS102U02		7-2-57	12		
			7-2-2					7-2-74			
			7-2-3			TS102U03		7-2-76	1		
			7-2-12			TS103P01	5935-160-1365	7-2-90	1		
			7-2-73			TS103U02		7-2-77	1		
			7-2-94			TYPE 46-461	5910-280-6968	7-2-195	2		
			7-2-95			T103A-2		7-2-70	1		
			7-2-98			UG-625/U		7-2-60	2		
			7-2-100					7-2-146			
			7-2-103			UPT-4445	5910-195-8611	7-2-128	1		
			7-2-104			WA-101-4		7-2-38	1		
			7-2-105			WA-109-17		7-2-41	12		
			7-2-115					7-2-131			
			7-2-132			WA-109-38		7-5-8	1		
			7-2-147			WA-109-40		7-2-162	2		
			7-2-190			WA-109-56		7-2-25	8		
			7-2-194			WA-115		7-2-16	2		
			7-2-195			OA2	5960-188-3564	7-2-80	1		
			7-2-222			1045		7-2-68	2		
			7-2-291					7-2-124			
			7-3-4			1066AX		7-2-113	1		
SCBS0632BN6			7-3-13			12AX7	5960-166-7664	7-2-86	1		
SCBS0632BN7			7-4-3	2		12844		7-2-140	1		
SCBS0632BN9			7-2-97	2		1450JA		7-2-15	2		
			7-2-110	12		1513A		7-2-294	2		
			7-2-117			1520		7-2-296	1		
SCBS1032BN5			7-2-105	2		1520A		7-2-263	8		
SCBS1032BN6			7-2-303	1				7-2-295			
SCFS0256BN5			7-2-33	3		1540A		7-2-56	3		
SCFS0348BN4			7-2-37	2				7-2-293			
SCFS0440BN4			7-2-43	4		160-110		7-2-221	6		
			7-4-2			16034		7-2-145	1		
SCFS0440BN8			7-2-25	12		1774		7-2-143	2		
			7-2-42					7-2-144			
			7-2-71			2WE06MRN		7-2-307	16		
SCFS0632BN24			7-5-5	1		20F5000	5905-100-7890	7-2-162	1		
SCFS0632BN38			7-2-304	6		2153		7-2-25	8		
SCFS0632BN40			7-2-162	1		2277B		7-2-127	1		
SCFS0632BN5			7-2-193	12		312002		7-2-141	1		
SCFS0632BN6			7-2-307	16		3482-11		7-2-96	4		
SCFS0632BN8			7-2-111	6				7-2-97			
SCFS0832BN28			7-2-299	8		4		7-2-36	1		
SCFS0832BN6			7-2-72	6		4103-AD		7-2-11	2		
SFB0256SK3			7-2-22	14		44		7-2-137	1		
			7-2-24			44/AF		7-2-136	2		
			7-2-34			5U4G	5960-188-3948	7-2-88	1		
SM-102			7-4-8	1		51B13405		7-2-94	4		
SM-127-D-1032			7-2-16	2				7-2-147			
SP-102			7-3-12	2		56A		7-2-194	2		
			7-4-8			6AB4	5960-262-0190	7-2-81	1		
SP-117			7-2-303	1		6AG5	5960-275-7497	7-2-58	3		
SP-122			7-2-29	2				7-2-85			
SS-50	5930-578-3350		7-2-149	2		6AL5	5960-296-0985	7-2-84	1		
SW-147	5930-504-7357		7-3-11	1		6AU6	5960-166-7676	7-2-83	1		

PART NUMBER	STOCK NUMBER		FIGURE & INDEX NUMBER	QTY PER ART.	SOURCE CODE	PART NUMBER	STOCK NUMBER		FIGURE & INDEX NUMBER	QTY PER ART.	SOURCE CODE
	CLASS CODE	SERIAL OR PART NUMBER					CLASS CODE	SERIAL OR PART NUMBER			
6BA6		5960-264-2089	7-2-79	4		811H1K35			7-2-167	2	
6BE6		5960-264-3002	7-2-78	1					7-5-12		
6BC6		5960-230-5307	7-2-82	2		8113	5935-557-9330		7-2-148	1	
6V6		5960-100-5893	7-2-87	1		817H1K70	5910-644-0727		7-5-13	1	
6390			7-5-4	1		8517			7-2-93	1	
705			7-2-8	1		8599			7-2-92	1	
708			7-2-138	2		8879			7-2-41	10	



SECTION 9  
REFERENCE DESIGNATION INDEX

REFERENCE DESIGNATION	FIGURE INDEX	CLASS CODE OR STOCK NO.	PART NO.	REFERENCE DESIGNATION	FIGURE INDEX	CLASS CODE OR STOCK NO.	PART NO.
C1	7-2-266		L36AGD103PYV	C17	7-2-239		L36AGD103PYV
C10	7-2-107		CT-104-5	C18	7-2-195	5910-280-6968	TYPE 46-461
C100	7-4-6	5910-648-9291	GP2K221	C19	7-2-195	5910-280-6968	TYPE 46-461
C101	7-2-151		L36AGD103PYV	C2	7-2-266		L36AGD103PYV
C102	7-2-151		L36AGD103PYV	C20	7-2-195	5910-280-6968	TYPE 46-461
C103	7-2-151		L36AGD103PYV	C21	7-2-195	5910-280-6968	TYPE 46-461
C104	7-2-128	5910-195-8611	UPT-4445	C22	7-2-195	5910-280-6968	TYPE 46-461
C105	7-2-267		CC-100-23	C23	7-2-195	5910-280-6968	TYPE 46-461
C106	7-2-150	5910-557-5297	CT-104-3	C24	7-2-239		L36AGD103PYV
C107	7-2-239		L36AGD103PYV	C25	7-2-239		L36AGD103PYV
C108	7-2-151		L36AGD103PYV	C26	7-2-239		L36AGD103PYV
C109	7-2-254	5910-197-1559	CC21SL050C	C29	7-2-266		L36AGD103PYV
C11	7-2-239		L36AGD103PYV	C3	7-2-203	5910-197-1559	CC21SL050C
C110	7-2-266		L36AGD103PYV	C30	7-2-266		L36AGD103PYV
C111	7-2-266		L36AGD103PYV	C31	7-2-266		L36AGD103PYV
C112	7-2-151		L36AGD103PYV	C36	7-2-266		L36AGD103PYV
C113	7-2-151		L36AGD103PYV	C37	7-2-266		L36AGD103PYV
C114	7-2-259		CC20UJ6R8D	C38	7-2-266		L36AGD103PYV
C115	7-2-213	5910-112-8589	CC21SL220K	C4	7-2-206	5910-197-1559	CC21SL050C
C116	7-2-151		L36AGD103PYV	C40	7-2-266		L36AGD103PYV
C117	7-2-279	5910-636-2110	CM15E151G	C42	7-3-4		CT-105-1
C118	7-2-279	5910-636-2110	CM15E151G	C43	7-3-3		CM15C030M
C119	7-2-239		L36AGD103PYV	C44	7-3-6	5910-191-0910	CM20D301G
C12	7-2-239		L36AGD103PYV	C45	7-2-266		L36AGD103PYV
C120	7-2-239		L36AGD103PYV	C46	7-2-266		L36AGD103PYV
C121	7-2-239		L36AGD103PYV	C47	7-2-266		L36AGD103PYV
C122	7-2-260		N1400A2R2	C48	7-2-266		L36AGD103PYV
C123	7-2-260		N1400A2R2	C5	7-2-199	5910-112-8209	CC21SL470K
C124	7-2-262	5910-581-2159	CM20B102K	C50	7-2-266		L36AGD103PYV
C125	7-2-258	5910-129-9199	CC20UJ100J	C52	7-2-266		L36AGD103PYV
C126	7-2-257		CC20RH47C	C53	7-2-266		L36AGD103PYV
C127	7-2-231	5910-688-0240	CC45UJ751J	C54	7-2-266		L36AGD103PYV
C128	7-2-232	5910-112-8380	CC35UJ181J	C56	7-2-266		L36AGD103PYV
C129	7-2-235		CC45SH221J	C57	7-2-277	5910-112-8209	CC21SL470K
C13	7-2-209		CM20D162F	C59	7-2-182	5910-245-4645	CC21SL150J
C130	7-2-238		CC32SH101J	C6	7-2-239		L36AGD103PYV
C131	7-2-229	5910-643-8994	CC45TH391J	C63	7-2-151		L36AGD103PYV
C132	7-2-239		L36AGD103PYV	C65	7-2-171	5910-648-9291	GP2K221
C133	7-2-239		L36AGD103PYV	C66	7-2-171	5910-648-9291	GP2K221
C134	7-2-151		L36AGD103PYV	C67	7-2-151		L36AGD103PYV
C135	7-2-151		L36AGD103PYV	C68	7-2-178	5910-112-8270	CC21SL510G
C136	7-2-156	5910-667-8885	GP2K151	C69	7-2-180		PJ455
C137	7-2-290		CC21SL080G	C7	7-2-239		L36AGD103PYV
C138	7-2-286	5910-666-8879	CM15E111G	C70	7-2-151		L36AGD103PYV
C139	7-2-280	5910-254-5991	CM15E560G	C72	7-5-12		811H1K35
C14	7-2-211	5910-668-0610	CM15C271G	C73	7-5-13	5910-644-0727	817H1K70
C140	7-2-280	5910-254-5991	CM15E560G	C75	7-2-151		L36AGD103PYV
C141	7-2-281	5910-666-8879	CM15E111G	C76	7-2-289		CE-100
C144	7-2-121		CC26CH300J	C77	7-2-161		BR-2025
C145	7-2-48		L36AGD103PTV	C78	7-2-247	5910-668-0188	CC21UJ470J
C146	7-2-55	5910-112-8209	CC21SL470K	C79	7-2-224	5910-191-1844	CM20D431F
C147	7-2-48		L36AGD103PTV	C8	7-2-116	5910-607-2805	CB-131
C148	7-2-48		L36AGD103PTV	C80	7-2-221		160-110
C149	7-2-43		CT-104-1	C81	7-2-226		CM20D1091F
C15	7-2-219	5910-197-1559	CC21SL050C	C82	7-2-221		160-110
C150	7-2-166		811H1K35	C83	7-2-231	5910-688-0240	CC45UJ751J
C151	7-2-151		L36AGD103PYV	C84	7-2-221		160-110
C152	7-2-151		L36AGD103PYV	C85	7-2-234	5910-112-7981	CC35CG910J
C16	7-2-239		L36AGD103PYV	C86	7-2-252		CC20UJ4R7C

REFERENCE DESIG- NATION	FIGURE INDEX	CLASS CODE OR STOCK NO.	PART NO.	REFERENCE DESIG- NATION	FIGURE INDEX	CLASS CODE OR STOCK NO.	PART NO.
C87	7-2-221		160-110	R27	7-2-273		RC20GF511K
C88	7-2-237		CC45SH331J	R28	7-2-274	5905-195-6761	RC20GF104K
C89	7-2-221		160-110	R29	7-2-184	5905-279-3502	RC20GF123K
C9	7-2-117	5910-296-4987	CB-130	R3	7-2-204	5905-279-3504	RC20GF472J
C90	7-2-221		160-110	R31	7-2-152	5905-279-3503	RC20GF682K
C91	7-2-252		CC20UJ4R7C	R32	7-3-7	5905-190-8883	RC20GF100J
C92	7-2-228	5910-519-4374	CC45SH391J	R33	7-3-7	5905-190-8883	RC20GF100J
C93	7-2-247	5910-668-0188	CC21UJ470J	R34	7-3-8	5905-279-3519	RC20GF220J
C94	7-2-239		L36AGD103PYV	R35	7-3-9	5905-190-8889	RC20GF101J
C95	7-2-239		L36AGD103PYV	R36	7-2-155	5905-279-3519	RC20GF220K
C96	7-2-239		L36AGD103PYV	R37	7-2-188	5905-279-2513	RC20GF105K
C97	7-2-264		PJ4S5	R38	7-2-187	5905-195-6761	RC20GF104K
C98	7-4-5	5910-264-9443	CM20D152G	R39	7-2-276	5905-279-3513	RC20GF221K
C99	7-4-2		CT-104-4	R4	7-2-207	5905-299-2022	RC32GF223J
E1	7-2-143		1774	R40	7-2-186	5905-299-2011	RC32GF563K
E2	7-2-144		1774	R42	7-2-176	5905-299-2036	RC32GF682K
F1	7-2-141		312002	R43	7-2-187	5905-195-6761	RC20GF104K
I1	7-2-136		44/AF	R44	7-2-155	5905-279-3519	RC20GF220K
I2	7-2-136		44/AF	R45	7-2-164	5905-279-3513	RC20GF221K
I3	7-2-137		44	R46	7-2-184	5905-279-3502	RC20GF123K
J1	7-2-148	5935-557-9330	8113	R47	7-2-186	5905-299-2011	RC32GF563K
J2	7-2-8		705	R49	7-2-183	5905-279-2675	RC42GF333J
J3	7-2-140		12844	R5	7-2-200	5905-299-2028	RC32GF153J
J4	7-2-145		16034	R50	7-2-106	5905-173-6955	RV4ATS103B
J5	7-2-60		UG-625/U	R51	7-2-292	5905-279-2527	RC42GF223J
J6	7-2-146		UG-625/U	R52	7-2-185	5905-279-2528	RC42GF682K
L1	7-2-196	5950-606-3732	A-892	R53	7-2-155	5905-279-3519	RC20GF220K
L10	7-2-216	5960-578-1996	A-964	R54	7-2-164	5905-279-3513	RC20GF221K
L11	7-2-218	5950-607-2806	A-965	R55	7-2-278	5905-299-2011	RC32GF563K
L12	7-2-212	5950-607-2807	A-966	R57	7-2-176	5905-299-2036	RC32GF682K
L13	7-2-223	5950-578-1995	A-894	R58	7-2-172	5905-254-9201	RC20GF473K
L14	7-2-225	5950-578-8265	A-896	R59	7-2-169	5905-279-2513	RC20GF105K
L15	7-2-230	5950-568-5000	A-899	R6	7-2-243	5905-299-2040	RC32GF472K
L16	7-2-233	5950-578-8026	A-903	R60	7-2-173	5905-192-0667	RC20GF224K
L17	7-2-236		A-1356	R61	7-2-170	5905-279-2515	RC20GF474K
L18	7-2-227		A-1355	R62	7-2-168	5905-221-5848	RC20GF824K
L19	7-2-73	5950-647-9510	A-1041	R63	7-2-165	5905-190-8874	RC20GF125K
L2	7-2-197	5950-578-1998	A-897	R64	7-2-165	5905-190-8874	RC20GF125K
L20	7-3-12		A-944	R65	7-2-177	5905-279-3504	RC20GF472K
L21	7-5-4		6390	R66	7-2-179	5905-279-2519	RC20GF334K
L22	7-4-8		CI-109-11	R67	7-2-287	5905-279-1888	RC20GF825K
L23	7-2-127		2277B	R68	7-2-6	5905-279-1829	RV4ATRD105D
L25	7-2-271	5950-644-5646	CL-108-6	R69	7-2-164	5905-279-3513	RC20GF221K
L26	7-2-174	5950-578-8004	A-1045	R70	7-2-158	5905-192-3981	RC20GF124K
L27	7-2-174	5950-578-8004	A-1045	R71	7-2-10		RV4ATSC152B
L28	7-2-282	5950-578-8003	A-1076	R72	7-5-11	5905-299-2022	RC32GF223J
L29	7-2-283	5950-578-8007	A-1077	R73	7-2-157	5905-279-2515	RC20GF474K
L3	7-2-201	5950-578-1801	A-898	R74	7-2-163		RC42GF301K
L30	7-2-282	5950-578-8003	A-1076	R75	7-2-265		RC42GF561K
L31	7-2-253	5950-578-8004	A-1045	R76	7-2-160	5905-171-1986	RC20GF563K
L32	7-2-284	5950-578-8002	A-1345	R77	7-2-153	5905-171-2000	RC20GF684K
L33	7-2-284	5950-578-8002	A-1345	R78	7-2-251	5905-171-2004	RC20GF223K
L34	7-2-284	5950-578-8002	A-1345	R79	7-2-246	5905-279-3499	RC20GF272K
L36	7-2-49		CL-100-5	R8	7-2-242	5905-279-3519	RC20GF220K
L4	7-2-202	5950-578-5028	A-901	R80	7-2-251	5905-171-2004	RC20GF223K
L5	7-2-205	5950-608-2146	A-900	R81	7-2-5	5905-578-4129	RV4BTRD502E
L6	7-2-198	5950-578-1997	A-905	R82	7-4-7	5905-254-9201	RC20GF473K
L7	7-2-208	5950-547-8545	A-961	R83	7-2-155	5905-279-3519	RC20GF220K
L8	7-2-210	5950-578-1802	A-962	R84	7-2-158	5905-192-3981	RC20GF124K
L9	7-2-215	5950-578-1994	A-963	R85	7-2-158	5905-192-3981	RC20GF124K
M1	7-2-33	6625-696-5548	MR-107	R86	7-2-159	5905-192-0667	RC20GF224K
R1	7-2-164	5905-279-3513	RC20GF221K	R87	7-2-162	5905-100-7890	20F5000
R10	7-2-240	5905-279-3513	RC20GF221K	R88	7-2-181	5905-101-7586	RC32GF4R7J
R100	7-2-54	5905-252-4018	RC20GF470K	R89	7-2-255	5905-190-8883	RC20GF100K
R101	7-2-47	5905-284-2776	RC32GF223K	R9	7-2-241	5905-195-5546	RC20GF390K
R102	7-2-51	5905-195-6806	RC20GF102K	R90	7-2-255	5905-190-8883	RC20GF100K
R103	7-2-50	5905-171-2004	RC20GF223K	R91	7-2-288	5905-190-8883	RC20GF100K
R104	7-2-46		RC42GF680K	R92	7-2-214	5905-171-1976	RC42GF153J
R11	7-2-244	5905-171-1986	RC20GF563K	R93	7-2-261	5905-195-6806	RC20GF102J
R12	7-2-217	5905-195-6806	RC20GF102K	R94	7-2-101		RA101ASSA251A
R13	7-2-220	5905-171-1976	RC42GF153J	R95	7-2-154	5905-190-8865	RC20GF274K
R14	7-2-248	5905-279-3504	RC20GF472K	R96	7-2-152	5905-279-3503	RC20GF682K
R15	7-2-242	5905-279-3519	RC20GF220K	R97	7-2-157	5905-279-2515	RC20GF474K
R16	7-2-256	5905-195-6761	RC20GF104K	R98	7-2-53		RC20GF121K
R17	7-2-249	5905-190-8889	RC20GF101J	R99	7-2-52	5905-254-9201	RC20GF473K
R18	7-2-245	5905-192-3971	RC20GF331K	S11	7-2-20		T-110-62
R19	7-2-246	5905-279-3499	RC20GF272K	S12	7-2-45		SW-222
R2	7-2-274	5905-195-6761	RC20GF104K	S13	7-2-122		SW-203
R20	7-2-250	5905-279-2522	RC20GF154K	S2	7-3-11	5930-504-7357	SW-147
R21	7-2-177	5905-279-3504	RC20GF472K	S3	7-2-20		T-110-62
R22	7-2-268	5905-185-8510	RC20GF103K	S4	7-2-20		T-110-62
R23	7-2-269	5905-252-4018	RC20GF470K	S5	7-5-15	5930-578-2321	SW-156
R24	7-2-270		RC20GF151K	S6	7-2-149	5930-578-3350	SS-50
R26	7-2-269	5905-252-4018	RC20GF470K	S7	7-2-149	5930-578-3350	SS-50

REFERENCE DESIG- NATION	FIGURE INDEX	CLASS CODE OR STOCK NO.	PART NO.	REFERENCE DESIG- NATION	FIGURE INDEX	CLASS CODE OR STOCK NO.	PART NO.
S8	7-2-20		T-110-62	XV14	7-2-94		51B13405
S9	7-2-20		T-110-62	XV15	7-2-89	5935-260-0516	TS102P01
T1	7-2-291	5950-578-8553	TR-116	XV16	7-2-89	5935-260-0516	TS102P01
T10	7-2-126		TF-169	XV17	7-2-59	5935-260-0516	TS102P01
T11	7-2-275		A-989	XV2	7-2-89	5935-260-0516	TS102P01
T2	7-2-95		A-1040	XV3	7-2-89	5935-260-0516	TS102P01
T3	7-2-102		A-1038	XV4	7-2-89	5935-260-0516	TS102P01
T4	7-2-102		A-1038	XV5	7-2-89	5935-260-0516	TS102P01
T5	7-2-103	5950-578-8552	A-1034	XV6	7-2-89	5935-260-0516	TS102P01
T6	7-2-99		A-1039-1-2	XV7	7-2-89	5935-260-0516	TS102P01
T7	7-2-99		A-1039-1-2	XV8	7-2-89	5935-260-0516	TS102P01
T8	7-2-100		A-1039-3	XV9	7-2-89	5935-260-0516	TS102P01
T9	7-2-125	5950-578-8267	TF-159	XY10	7-2-41		8879
V1	7-2-81	5960-262-0190	6AB4	XY11	7-2-41		8879
V10	7-2-86	5960-166-7664	12AX7	XY12	7-2-41		8879
V11	7-2-87	5960-100-5893	6V6	XY13	7-2-41		8879
V12	7-2-85	5960-275-7497	6AG5	XY3	7-2-131		K-33102
V13	7-2-85	5960-275-7497	6AG5	XY4	7-2-41		8879
V14	7-2-88	5960-188-3948	5U4G	XY5	7-2-41		8879
V15	7-2-80	5960-188-3564	0A2	XY6	7-2-41		8879
V16	7-2-82	5960-230-5307	6CB6	XY7	7-2-41		8879
V17	7-2-58	5960-275-7497	6AG5	XY8	7-2-41		8879
V2	7-2-82	5960-230-5307	6CB6	XY9	7-2-41		8879
V3	7-2-83	5960-166-7676	6AU6	X1	7-2-147		51B13405
V4	7-2-78	5960-264-3002	6BE6	X2	7-2-147		51B13405
V5	7-2-79	5960-264-2089	6BA6	Y1	7-3-2		CR-102
V6	7-2-79	5960-264-2089	6BA6	Y10	7-2-40		CR-18/U
V7	7-2-79	5960-264-2089	6BA6	Y11	7-2-40		CR-18/U
V8	7-2-79	5960-264-2089	6BA6	Y12	7-2-40		CR-18/U
V9	7-2-84	5960-296-0985	6AL5	Y13	7-2-40		CR-18/U
XV1	7-2-142		HKP-M	Y2	7-2-272		CR-103
X11	7-2-138		708	Y3	7-2-129		CR-100
X12	7-2-138		708	Y4	7-2-40		CR-18/U
X13	7-2-139		PT-179	Y5	7-2-40		CR-18/U
XV1	7-2-89	5935-260-0516	TS102P01	Y6	7-2-40		CR-18/U
XV10	7-2-90	5935-160-1365	TS103P01	Y7	7-2-40		CR-18/U
XV11	7-2-94		51B13405	Y8	7-2-40		CR-18/U
XV12	7-2-91	5935-232-3758	TS102C01	Y9	7-2-40		CR-18/U
XV13	7-2-89	5935-260-0516	TS102P01				

