

INSTRUCTION BOOK
for
COMMUNICATIONS
RECEIVER
MODEL GPR-90

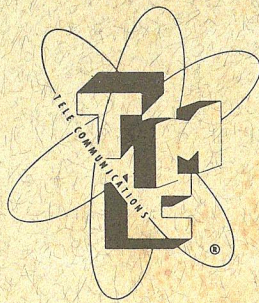

THE TECHNICAL MATERIEL CORP.

Mamaroneck, New York

Ottawa, Ontario

PRICE \$1.25

INSTRUCTION BOOK

for

**COMMUNICATIONS
RECEIVER**

MODEL GPR-90

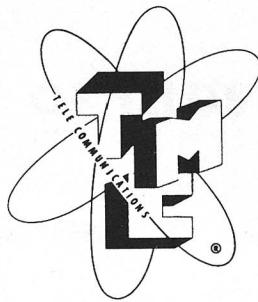

THE TECHNICAL MATERIEL CORP.

Mamaroneck, New York

Ottawa, Ontario

INSTRUCTION BOOK
FOR
COMMUNICATIONS
REPAIR
MANUAL

Copyright 1957
Technical Materiel Corporation

TABLE OF CONTENTS

SECTION I—GENERAL DESCRIPTION		Paragraph	Page
Paragraph	Page	4. Single Sideband Reception	3-3
		5. S-Meter	3-3
1. Description of the Receiver	1-1		
2. Technical Specifications	1-2		
SECTION II—INSTALLATION			
1. Unpacking	2-1		
2. Location	2-1		
3. Antenna	2-1		
4. Installation	2-2		
5. Break-in Operation	2-2		
6. Phono Input Connections	2-2		
7. Single Sideband Connections	2-3		
8. DC Operation	2-4		
9. Accessories	2-4		
SECTION III—OPERATION			
1. Controls	3-0		
2. AM Reception	3-1		
3. CW Reception	3-2		
		SECTION IV—ALIGNMENT	
		1. General	4-1
		2. Equipment Required	4-1
		3. IF Alignment	4-1
		4. 455 Kc	4-1
		5. BFO	4-2
		6. 3.955 Mc	4-2
		7. RF Alignment	4-3
		8. S-Meter Calibration	4-3
		9. Hum Balance Adjustment	4-4
		SECTION V—SERVICE AND TEST DATA	
		1. Voltage Measurements	5-1
		2. Resistance Measurements	5-1
		3. Performance Data	5-1
		4. Operating Conditions	5-1
		5. Electrical Parts List	5-4

LIST OF ILLUSTRATIONS

SECTION I—GENERAL DESCRIPTION		SECTION III—OPERATION	
Figure	Page	Figure	Page
1-1. Front View, Model GPR-90	1-1	3-1. Front Panel Controls	3-1
		3-2. GPR-90 Connections for Sideband Slicer	3-2
SECTION II—INSTALLATION		SECTION IV—ALIGNMENT	
2-1. Typical Antenna Installations	2-2	4-1. Top View, Model GPR-90	4-2
2-2. Typical Switching Circuit for Break-in Operation	2-2	4-2. Bottom View, Model GPR-90	4-3
2-3. Wiring Diagram for DC Operation	2-3	4-3. Signal Generator Connections for RF Alignment	4-4
2-4. Rear View of Receiver	2-3		
2-5. Accessory Power Socket Connections	2-3		
SECTION V—SERVICE AND TEST DATA			
		5-1. Audio Fidelity Curves	
		5-2. IF Selectivity Curves	
		5-3. Schematic Diagram	

LIST OF TABLES

SECTION IV—ALIGNMENT

Table	Page
4-1. Alignment Data	4-4

SECTION V—SERVICE AND TEST DATA

5-1. Voltage Data Chart	5-1
5-2. Resistance Data Chart	5-2
5-3. I.F. Bandwidth Data Chart at 455 Kc	5-3
5-4. R.F. Sensitivity Data Chart	5-3

SECTION I

GENERAL DESCRIPTION

1. DESCRIPTION

The TMC Model GPR-90 is a modern, precision built communications receiver designed to give years of satisfactory service to the most discriminating user. It offers continuous coverage from 540 Kc to 31.5 Mc in six bands for the reception of AM telephone, CW telegraph or teletype, and MCW telegraph signals. Calibrated electrical bandspread is provided for amateur operation in the 160, 80, 40, 20, 15, 11 and 10 meter bands. In addition to the frequency scales, both dials have arbitrary logging scales calibrated from 0 to 100.

The 15 tubes employed in the GPR receiver assure adequate sensitivity which averages one microvolt or better for a 10 db signal plus noise to noise power ratio. In the broadcast band the sensitivity is purposely held to approximately 5 microvolts.

Dual conversion is employed in bands 4, 5 and 6 for improved image rejection. A grounded grid RF amplifier at the front end (used in bands 3, 4, 5 and 6) gives additional improvement to the image rejection and improves the signal to noise ratio.

A broadband antenna input transformer coupled to the grounded grid RF amplifier provides 75 and 300 ohms antenna impedances balanced and unbalanced over the entire frequency range; thus assuring a constant antenna impedance match and a good noise figure.

An "S" meter is used for accurate tuning and to indicate the relative signal strength of received signals. The meter calibration is in "S" units from 1 to 9 and in decibels above S-9 to +40 db. Fifty microvolts equals S-9.

The RF selectivity control provides 6 steps of selectivity: .25 Kc to 2 Kc on crystal filter,



Figure 1-1. Front View, Model GPR-90

and 7 Kc at 6 db down in non-crystal. Audio selectivity is controlled by a 3 position switch labeled Normal, Lowpass, and 1200 cycles Peak. When set to 1200 cycles Peak, the audio bandwidth at 10 db down from the peak can be varied from 600 cycles to 1600 cycles by means of the Audio Spread control.

A high degree of frequency stability has been obtained in the oscillator circuit by careful design and the use of ceramic coil forms, ceramic bandswitch, and ceramic tube socket; ceramic coil forms are also used in the RF and mixer tuning circuits.

A series type noise limiter is employed to effectively reduce noise from automobile ignition or pulse type interference from electrical equipment. The limiter can be turned on by a front panel switch.

The frequency of the beat frequency oscillator is controlled by the Pitch control which varies the audio beat note on CW signals from zero to plus or minus 3 Kc. The high stability of this BFO makes it possible to receive SSB signals.

The audio output circuit is designed to match 4, 8, 16 and 600 ohm loads, and is capable of delivering 2 watts of clean audio in the "Normal" position of the audio selector. A pad is inserted across the 600 ohm output terminal when phones are used.

The GPR-90 operates on 105-125 volt, 50-60 cycles AC power source and provision has been made for operation from an external power supply or batteries for emergency service in areas where AC power is not available.

2. TECHNICAL SPECIFICATIONS

FREQUENCY RANGE:

.54 to 31 megacycles in six bands.

BAND CHANGE:

By means of a front panel switch.

TYPE OF RECEPTION:

AM, CW, and MCW signals. FS when used with appropriate Audio Type Frequency Shift Converter.

TUNING SYSTEM:

Accurately calibrated main tuning dial plus auxiliary dial with full electrical bandspread.

ANTENNA INPUT CIRCUIT:

75 ohms unbalanced, 300 ohms balanced with built-in ferrite transformer providing accurate matching.

ANTENNA TRIMMER:

Front panel control permits peaking of antenna circuit.

BFO CIRCUIT:

Variable Frequency BFO.

SENSITIVITY:

Less than 5 microvolts from .54 to 1.5 Mc., one microvolt throughout the balance of the range. All measurements are for a 10 db signal to noise power ratio.

IMAGE RATIO:

Better than 60 db.

AVC CHARACTERISTICS:

With an 80 db change in the input signal, the output remains constant within 12 db.

SELECTIVITY:

Variable in six steps from 250 cycles to 5 kilocycles, 5 crystal and 1 non-crystal position.

OUTPUT IMPEDANCE:

4, 8, 16, and 600 ohms.

HUM LEVEL:

Better than 60 db.

OUTPUT POWER:

2 watts high quality audio output.

INPUT POWER:

105-125 volts, 50/60 cycles, approximately 90 watts.

NOISE LIMITER:

A highly effective Noise Limiter circuit is provided.

METERING:

Calibrated "S" meter.

AUDIO SELECTIVITY:

Specially designed Audio Selectivity control with variable bandwidth.

FRONT PANEL CONTROLS:

Main Tuning Dial
Bandspread Dial
Band Switch
Antenna Trimmer
Selectivity Switch
Crystal Phasing Control
Audio Filter Switch
Audio Filter Bandwidth Control
Standby Switch
Dial locks
Noise Limiter Switch

Audio Gain Control
Phone Jack
AVC/MANUAL Switch
BFO ON/OFF Switch
RF Gain and Power ON/OFF Switch
BFO Pitch

REAR PANEL FACILITIES:

Antenna Connections
Fuse
Loudspeaker Connections
Relay Standby Connections
Phono-ON/OFF Switch
Phono Input Jack
SSB Selector Switch.

ACCESSORY FACILITIES ON REAR PANEL:

Utility AC Outlet
Utility Power Socket provides
6.3 v. .6 amp. 250 v. .01 amp.
Emergency Power Input
Coaxial IF Output for SSB.
Audio Input for SSB.

DIVERSITY OPERATION:

The Model GPR-D is available for diversity application. Provisions are made for external control of the HFO, BFO, and IFO.

MOUNTING:

Cabinet or Rack Mounting.

SIZE: (a) Cabinet

20'' wide x 10'' high x 15'' deep.

(b) Rack Mounting

19'' wide x 8-3/4'' high x 14'' deep.

WEIGHT:

Net - 52 lbs.

Gross - 63 lbs. packed for domestic

110 lbs. packed for export.

TUBE COMPLEMENT:

6AB4 Grounded Grid Input RF Amplifier
6CB6 2nd RF
6AU6 1st Converter
6AG5 Oscillator
6BE6 2nd Converter and Oscillator
6BA6 IF Buffer Amplifier
3- 6BA6 IF Amplifiers
6AL5 Detector and Noise Limiter
6AG5 BFO
12AX7 AVC and Audio Amplifier
6V6 Output
OA2 Regulator
5U4G Rectifier
6CB6 Calibrator

SECTION II INSTALLATION

1. UNPACKING

Carefully unpack the GPR-90 receiver and check any instructions which may accompany the instrument. A close visual check should be made to ascertain any physical damage due to rough handling during transit. Upon receipt of damaged equipment, immediately notify the carrier as to the extent of damage.

2. LOCATION

Place the receiver in any location that permits free air circulation through the ventilation holes in the cabinet. Avoid warm locations such as radiators and heating ducts. The external speaker may be located in any desired position, although not recommended on top of the receiver cabinet because of undesirable microphonics.

3. ANTENNA

The antenna input of the receiver is designed for operation from any antenna such as single-

wire, half-wave doublet, or antennas with transmission line impedances of 75-300 ohms. Connections to the antennas are made through a 4 terminal strip at the rear of the receiver. When using unbalanced antennas, tie the common and ground terminals together with a jumper wire. A good external ground connected to the ground terminal of the antenna strip will frequently improve reception.

The simplest type antenna giving good all-around performance is the single-wire type having a length from 50 - 75 feet and should preferably be located away from neighboring objects.

Optimum performance over a narrow tuning range, particularly over the shortwave ranges, is obtained by a properly resonant half-wave doublet, folded dipole, or other matched antenna.

The overall length in feet of a half-wave doublet is determined by:-

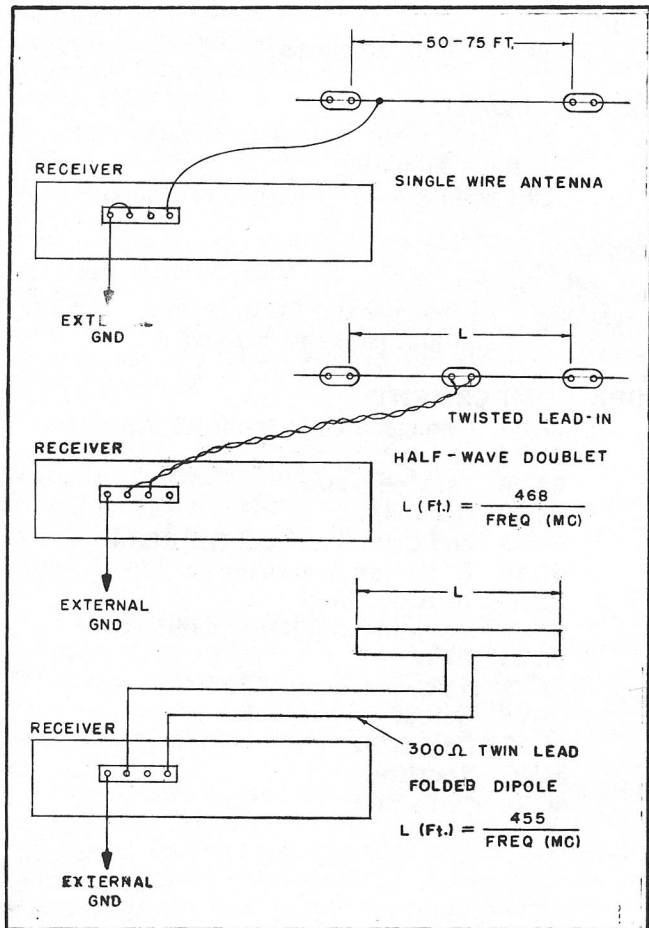

Figure 2-1. Typical Antenna Installations

$$L \text{ (in feet)} = \frac{468}{\text{Freq. (MC)}}$$

and for the folded dipole:-

$$L \text{ (in feet)} = \frac{455}{\text{Freq. (MC)}}$$

Several antenna installations are depicted in Figure 2-1.

Coaxial transmission lines with nominal 75 ohm impedance or 300 ohm twin-lead for the antenna lead-in will provide the best match at the receiver input. Any other coaxial line may be used at a slight mismatch. In the case of the coaxial line, connect outer braid to the ground terminal for balanced or unbalanced operation. For 300 ohm twin-lead connect directly to the 300 ohm antenna terminals.

4. INSTALLATION

Connect a permanent magnet dynamic speak-

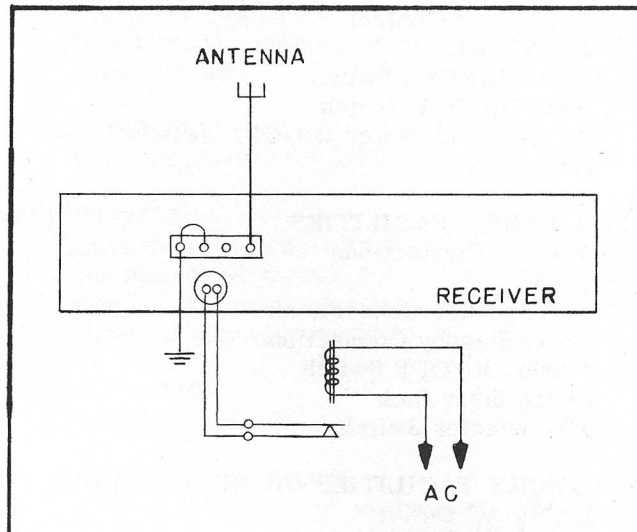

Figure 2-2. Typical Switching Circuit for Break-in Operation

er to the proper output speaker terminals on the rear of the receiver chassis.

Now connect an antenna and external ground such as described in paragraph 3 to the appropriate terminals.

Plug the receiver power cord into a socket supplying 105 - 125 volt 50-60 cycles. NOTE: The receiver will not operate from an AC source unless the AC Jumper Plug is inserted in the power socket at the rear of the receiver.

5. BREAK-IN OPERATION

The GPR-90 may be used for break-in operation by using the relay socket, provided at the receiver rear apron. In this mode of operation, the function of the Send-Receive Switch is performed through a normally closed relay. Parallel connections to the Send-Receive Switch are made at the relay socket. With the relay contacts closed, the Send-Receive Switch on Send, the receiver performs normally. When the transmitter is energized the relay contacts open, which disables the receiver. A typical break-in circuit appears in Figure 2-2.

6. PHONO INPUT CONNECTIONS

A high impedance Phone input jack is provided on the rear apron, and it requires .15 volts for full output. Any record player providing this voltage may, therefore, be used. A Radiophono slide switch is also provided which disables the RF portion of the receiver when using a record player. Connection between the pickup arm and the Phono input jack should be made with a single-pin phono plug and a shielded cable to prevent

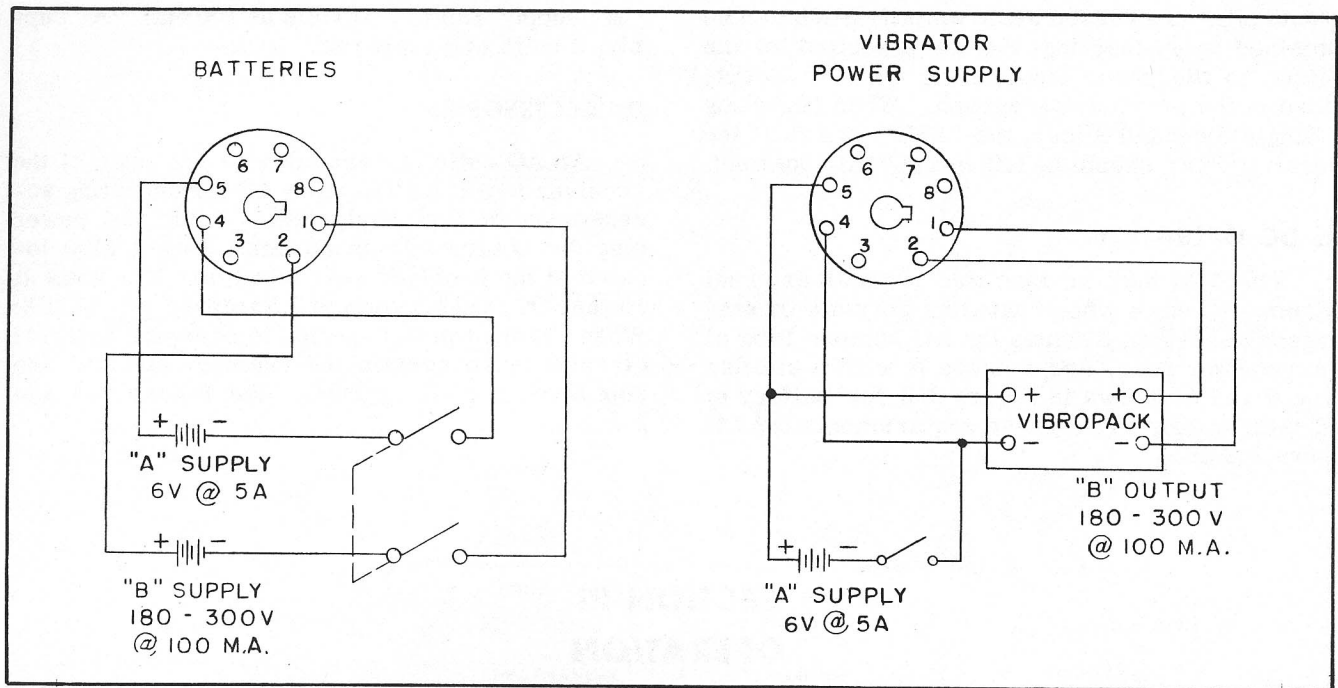

Figure 2-3. Wiring Diagram for DC Operation

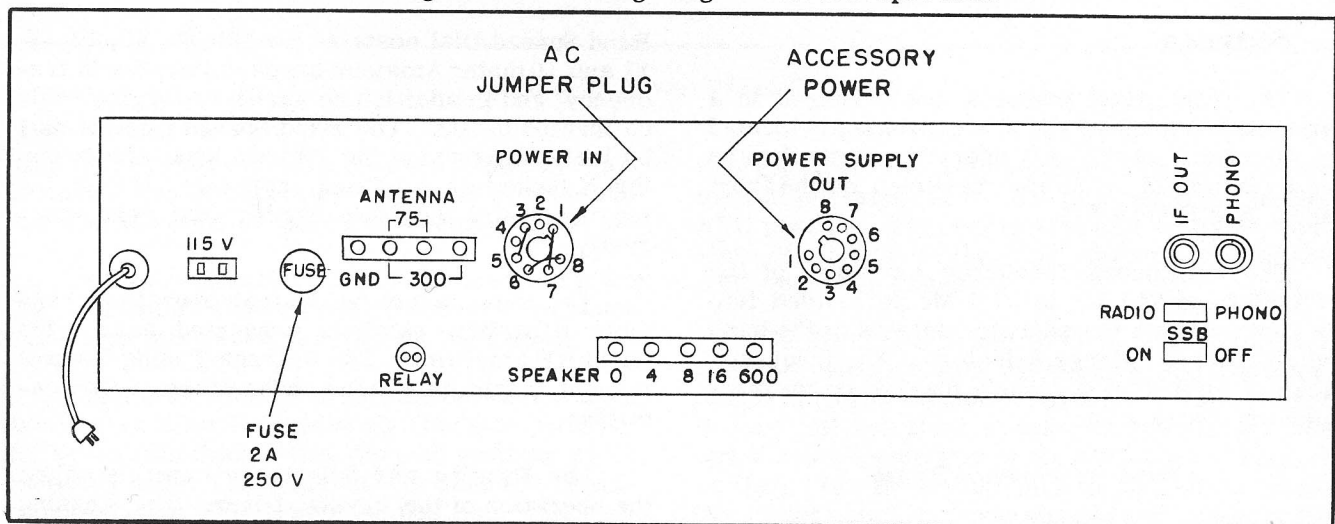

Figure 2-4. Rear View of Receiver

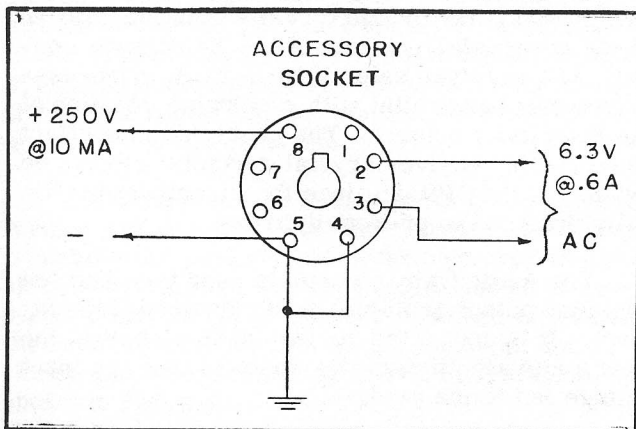

Figure 2-5. Accessory Power Socket Connections

hum pickup. The Phono input jack and Radio-phono switch are located on the receiver rear apron.

7. SINGLE SIDEBAND CONNECTIONS

The GPR-90 receiver is capable of operating on single sideband signals with the present beat frequency oscillator (BFO) injection. If desired, this injection can be raised by inserting a higher value for C59. An IF output jack at 455 Kc adjacent to the Phono input jack, is provided for input to operate a Single Sideband Slicer with the GPR-90. Connection to the IF jack should be made through a low capacity shielded cable and a single-pin

phono plug. Increased audio amplification can be obtained by connecting the audio output of the Slicer to the phono input of the GPR-90 as outlined in the previous paragraph. When operating a Single Sideband Slicer, the "SSB" switch at the receiver rear should be left in the "ON" position.

8. DC OPERATION

The GPR may be operated from an external DC power source when operating portable or emergency service. Remove the AC Jumper Plug at the receiver rear, and replace it with a similar type wired as shown in Figure 2-3 for battery or vibrator supply. The power requirements for DC operation are:

"B" supply, 180 to 300 volts at 100 ma; "A" supply, 6 volts at 5 amperes.

9. ACCESSORIES

An AC outlet is provided at the rear of the receiver supplying 115 volts AC for operating accessories or test equipment. Additional power may be obtained from an octal socket also located at the receiver rear supplying 250 volts at 10 ma. DC, and 6.3 volts at 0.6 ampere AC. NOTE: When filament power is used to energize external circuits make certain the filament circuits are kept above chassis ground. See Figure 2-4 and 2-5.

SECTION III OPERATION

1. CONTROLS

The front panel controls are arranged in a symmetrical manner and are conveniently located for operating ease. All operating controls are easily identified from the markings on the front panel. See Figure 3-1.

The continuous frequency coverage of the GPR-90 from 540 Kc to 31.5 Mc is divided into six ranges which the operator selects on the band switch marked "Range Selector". The frequency range of each band is clearly marked on the front panel and these are:

Band	Frequency Range
1	.54 --- 1.4 Mc
2	1.4 --- 3.3 Mc
3	3.3 --- 5.6 Mc
4	5.4 --- 9.6 Mc
5	9.4 --- 17.8 Mc
6	17.3 --- 31.5 Mc

The knob marked "Main Tuning" operates the main tuning capacitor through anti-backlash gears and drives the main frequency dial. This dial contains the six calibrated frequency ranges and an auxiliary logging scale calibrated 0-100. The Main Tuning Dial may be locked by turning the locking knob clockwise.

The Band Spread control operates the band spread tuning capacitor and is similar in mechanical design to the main tuning control. The

Band Spread Dial contains the 160, 80, 40, 20, 15, 11 and 10 meter Amateur bands calibrated in frequency; and in addition an auxiliary logging scale calibrated 0-100. The Band Spread Control may be locked by turning the locking knob clockwise. When locked at minimum capacity (100 on the logging scale) the Main Tuning Dial reads correctly.

The Antenna Tuning Control operates a variable capacitor which is connected across the tuned RF amplifier. The Antenna Tuning Control is used to trim this stage under varying load conditions.

The Phasing and Selectivity controls adjust the operation of the crystal filter. The Phasing control is used to reduce heterodyne or interfering signals by changing the null frequency of the crystal filter bridge circuit. It is inoperative in the noncrystal position of the Selectivity control. The receiver selectivity is made to increase (narrowing bandwidth) with clockwise rotation of the Selectivity control. The usual detuning effect observed in receiver crystal circuits will not be evident in the GPR-90 since the circuit is specifically designed to prevent detuning.

The Audio Gain control is used to adjust the receiver output (volume) to the desired listening level. It is connected to the input circuit of the first audio amplifying tube and controls the input voltage fed to the grid.

The RF gain and Power ON-OFF control is

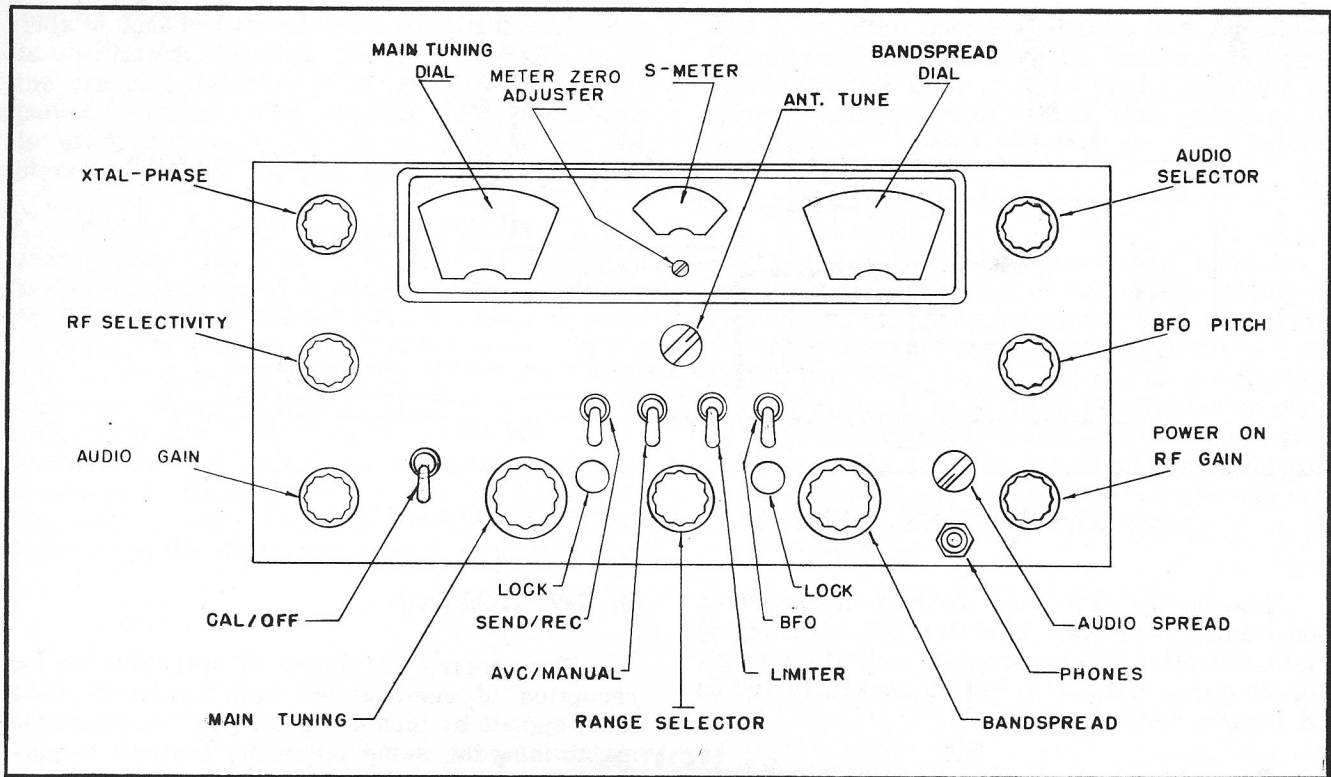

Figure 3-1. Front Panel Controls

used to turn the receiver ON and to adjust the gain of the RF and IF amplifier stages. Clockwise rotation of the control increases receiver gain.

The Noise Limiter control is used to switch ON the Limiter and is very effective in reducing pulse type interference riding on the signal.

The Audio Selector and Audio Spread controls are used to alter the frequency characteristics of the audio amplifier. The Normal position gives essentially flat response and is used for broadcast reception. The Low Pass position, which attenuates the higher audio frequencies, is used for general communications work. In both these positions the Audio Spread control is inoperative. In the 1200 cycles peak position of the Audio Selector, the audio amplifier becomes highly selective. The Audio Spread control then varies the sharpness of the response.

The Send-Receive switch permits the instant turning ON and OFF of the receiver. During transmission periods, when the receiver is disabled, the filaments are kept on, but the plate supply to the RF and IF stages are switched off. When the Send-Receive switch is set to Send, the receiver can be operated for break-in operation, as shown in Fig. 2-2.

The AVC-Manual switch is used to adjust

the receiver for automatic gain control or for manual operation of the RF gain control. In the AVC position, the receiver output remains constant regardless of the input variations over the AVC operating range.

The BFO switch and BFO Pitch controls are used for unmodulated radio-telegraph code and single sideband signals. The BFO switch is used to turn ON the Beat Frequency Oscillator, and operates independently of the AVC-Manual control setting. The BFO Pitch control is used to adjust the "beat note" on code signals and reinsert the carrier on single sideband reception. The Pitch control varies the BFO frequency approximately 3 Kc each side of its center frequency of 455 Kc.

2. AM RECEPTION

Install the receiver as described in Section II and set the following controls as follows:

Bandswitch	-- Desired Band
AVC/Manual	-- AVC
Limiter Switch	-- OFF
BFO Switch	-- OFF
Send/Receive	-- Rec.
SSB Switch (rear)	-- OFF
Phono Switch (rear)	-- Radio
Audio Selector	-- Normal
RF Selectivity	-- Non-xtal

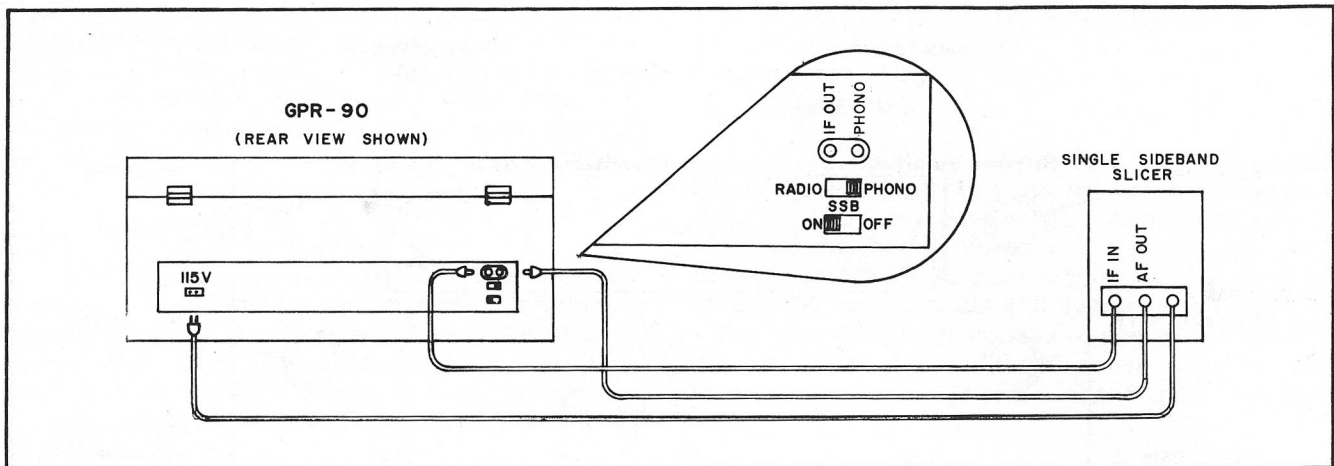

Figure 3-2. GPR Receiver Connected To Sideband Slicer

Loosen the dial locks counter-clockwise on both tuning controls. NOTE: The main tuning dial calibration will be accurate only if the bandspread tuning control is set or locked to 100 on the logging scale.

Turn the RF gain control fully clockwise. This control turns the receiver power on and the dials will be illuminated. Set the bandswitch for the desired listening band and tune the receiver, by using the main tuning knob, at the same time advancing the audio gain control to a good listening level. Adjust the Antenna Tune Control (located under the "S" meter) for maximum deflection on the "S" meter.

To tune the receiver over any amateur band proceed as follows: Set the main tuning dial so that the desired amateur band appears under the fiduciary (located on the logging scale) and lock it; then turn the bandswitch to the operating frequency range. Now tune the amateur band with the bandspread dial.

When the received signal is accompanied by excessive background noise (other than ignition or pulse type) increasing the RF selectivity of the receiver will improve the signal-to-noise ratio. The selectivity should be increased up to the point that a phone signal becomes unintelligible. An almost obliterated signal can sometimes be pulled through the noise hash and received 100% by the combined use of the RF and Audio selectivity (1200 cycles peak and the Spread control set to the wide position).

If the signal being received is interfered with or heterodynes with an adjacent carrier, adjust the Phasing control to reduce the interference. This control is set at zero for normal operation of the crystal filter.

3. CW RECEPTION

The receiver is placed in operation for the reception of unmodulated radiotelegraph code (CW) signals by turning ON the BFO but otherwise maintaining the same operating controls as outlined for AM reception. The unmodulated code signal is made audible by heterodyne action of the beat frequency oscillator with the IF signal. The BFO is set at a frequency slightly different from the 455 Kc (IF), the difference being equal to the pitch of the audible note desired.

First turn on the BFO and tune in a CW signal, then adjust its frequency by means of the Pitch control to give a pleasing note, generally 800 - 1200 cycles. This control may be used in either direction of the zero marking to obtain an audible note. NOTE: CW reception can be accomplished with AVC either on or off, but the experienced operator will usually turn AVC off, retard the RF gain and increase the audio, somewhat in the same manner as reception of SSB signals.

The use of the Audio Selectivity filter in the reception of CW signals can become quite effective by placing the AUDIO SELECTOR switch in the 1200 cycle peak position, setting the AUDIO SPREAD control to "SHARP" and varying the BFO PITCH control until the desired signal is peaked. In most cases interfering signals will be greatly reduced in volume and almost completely eliminated.

4. SINGLE SIDEBAND RECEPTION

Single sideband signals are characterized by the lack of carrier, unintelligibility, and fluctuations of the S-meter. It is necessary, therefore, to reinsert the carrier to obtain proper reception.

This is done by turning on the BFO (if the injection is insufficient, increase the value of C59); or by the use of a Sideband Slicer. Where the companion Signal Sideband Adapter, TMC Model GSB is used, reference should be made to the instruction manual for that unit.

Tune in the single sideband signal for maximum S-meter deflection. Turn the RF Gain control down until signal is barely audible. Turn on the BFO and tune the Pitch control very slowly until reception becomes intelligible. Generally the Pitch control setting should be near zero. If the signal is not intelligible after tuning the Pitch control, reset the control to the other side of the zero point and repeat the tuning procedure. Increasing the RF gain control over the initial setting will sometimes improve intelligibility. NOTE: Because of the slow tuning rate on the Bandsread

dial it is often possible to tune SSB signals by simply retarding the RF gain, boosting the audio and setting the BFO pitch to zero. Rotating the Bandsread dial slowly will then bring in the station.

5. S-METER

The S-meter performs a dual function; it provides a visual means of accurately tuning the receiver to the incoming signal, and it indicates the relative signal strength. The meter is calibrated in S units from 1 - 9, and to +40 db above S-9. The meter calibration is adjusted so that a 50 microvolt signal at the antenna terminals gives an S-9 reading at 7 Mc. The S-meter calibration will be correct only if the RF gain control is fully clockwise and the AVC/MAN switch is in the "AVC" position.

SECTION IV ALIGNMENT

1. GENERAL

The circuits of the Model GPR-90 have been carefully aligned at the factory by experienced technicians using precision test equipment. Re-alignment of the receiver should not be attempted until all other causes of faulty operation have been investigated. Alignment should not be required unless the receiver has been tampered with or some component part replaced in the stages containing tuned circuits. Alignment should be made only by technicians familiar with communication receivers and experienced with their alignment.

2. EQUIPMENT REQUIRED

Signal Generator accurately calibrated from 100 Kc to 31 Mc.

AC vacuum tube voltmeter or high impedance AC voltmeter with 100 volt range.

Non-metallic alignment tool with small metal tip, 600 ohm/10 watt load.

Pair of headphones (optional).

3. IF ALIGNMENT

The low frequency IF should be aligned first.

The recommended method for aligning the IF involves the use of a sweep frequency signal generator and an oscilloscope. Since these instruments are not usually available in the average service shop, an alternate procedure will be given. Remove the dust cover over the tuning capacitor shield compartment by removing the knurled nuts. Couple the signal generator to the lug of the middle section of the main tuning capacitor. See Figure 4-1. Connect the oscillator to ground by means of a short wire with alligator clips on each end. Connect the 600 ohm/10 watt load and the AC voltmeter across the 600 ohm speaker terminals. Set the receiver controls as follows:

Bandswitch	- .54 - 1.4 Mc
AVC/Manual	- Manual
Limiter	- Off
BFO	- Off
Send/Rec.	- Rec.
Audio Selector	- Normal
RF Selectivity	- See Text
Audio Gain	- Fully Clockwise
RF Gain	- Fully Clockwise
Main Tuning	- Half Capacity
Phasing Control	- O

4. 455 KC

Set the RF selectivity to the non-xtal position and the signal generator frequency to 455 Kc

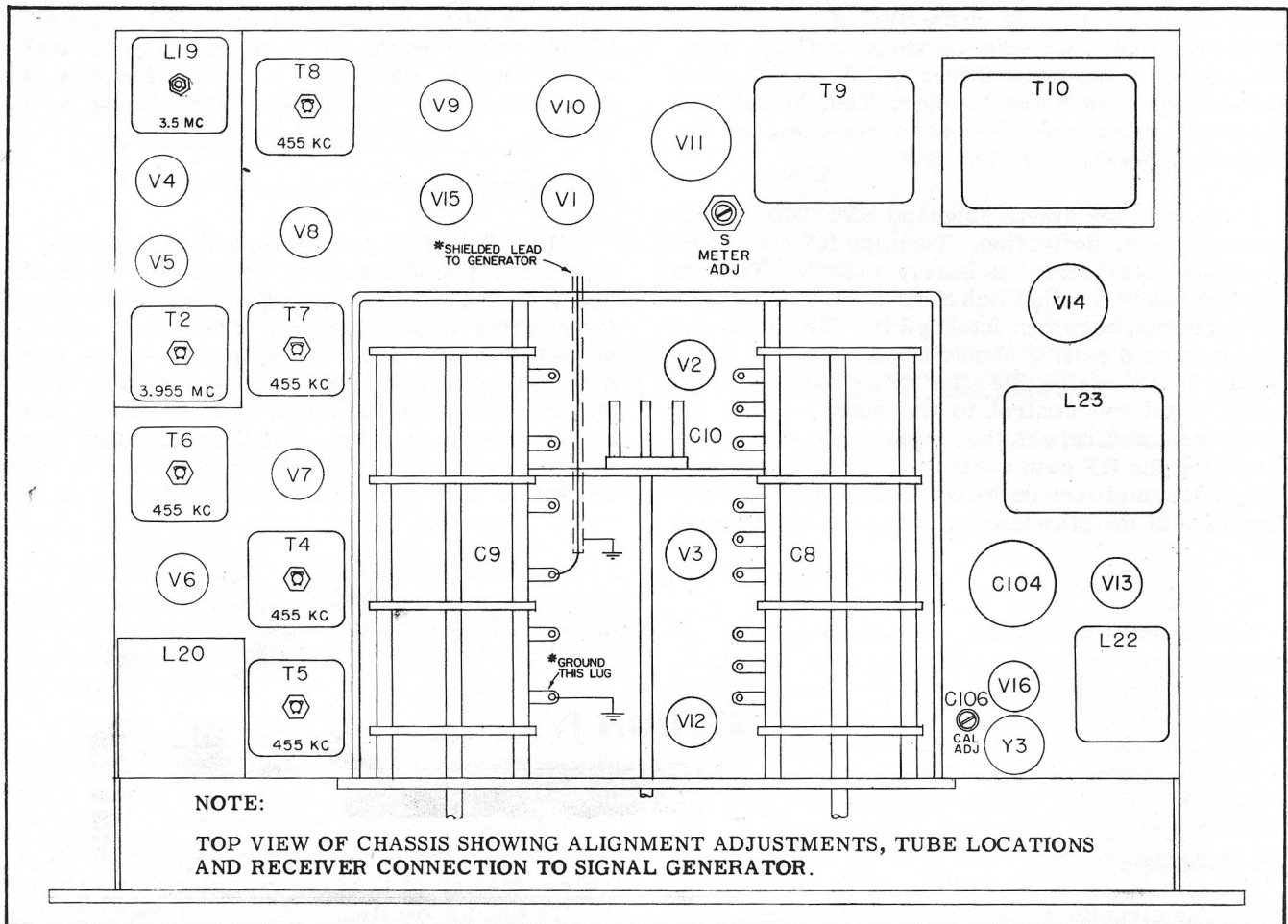

Figure 4-1. Top View of Chassis

modulated 30% at 400 cycles. A pair of headphones may be used for monitoring purposes if desired. Adjust the signal generator output until some deflection is noted on the output meter. Peak the following IF transformers T8, T7, T6, T5, (TOP & BOTTOM) T4 (TOP) for maximum output (See Figure 4-1 and 4-2 for the location of these adjustments).

During alignment the signal generator output should be progressively reduced to prevent receiver overload. Now turn the RF Selectivity control to the 2 Kc position and adjust the signal generator frequency for maximum meter deflection. In this way the signal generator frequency can be made to coincide with the 455 Kc crystal frequency in the receiver IF. The frequency of the signal generator should not be disturbed for the remainder of the 455 Kc IF and BFO alignment. Again peak T8, T7, T6, T5, (TOP & BOTTOM) T4 (TOP) and L20 for maximum output.

5. BFO

It is convenient to align the BFO at this point. Turn off the signal generator modulation and set

the BFO Pitch control to zero. Turn the BFO ON and adjust L22 for zero beat.

6. 3.955 MC

Set the Bandswitch to 5.4 - 9.6 Mc band. Set the signal generator to 3.955 Mc modulated 30% at 400 cycles. Adjust the 2nd Converter coil, L19, until an output is indicated. Since adjustment of L19 permits the 3.5 Mc crystal controlled oscillator to operate over a small frequency region, it must be set approximately in the middle of this range for stable operation. To determine stable oscillator operation momentarily turn the receiver off and on. If the receiver continues to operate after interruption L19 is set correctly. Once the oscillator coil is adjusted to 3.5 Mc, adjust T3 (BOTTOM), T2 (TOP & BOTTOM) for maximum output.

During this test use sufficient generator output, but not enough to overload the receiver. This completes the IF alignment. Remove the generator leads from the tuning capacitor and the oscillator ground. Replace the dust cover over the tuning capacitor compartment.

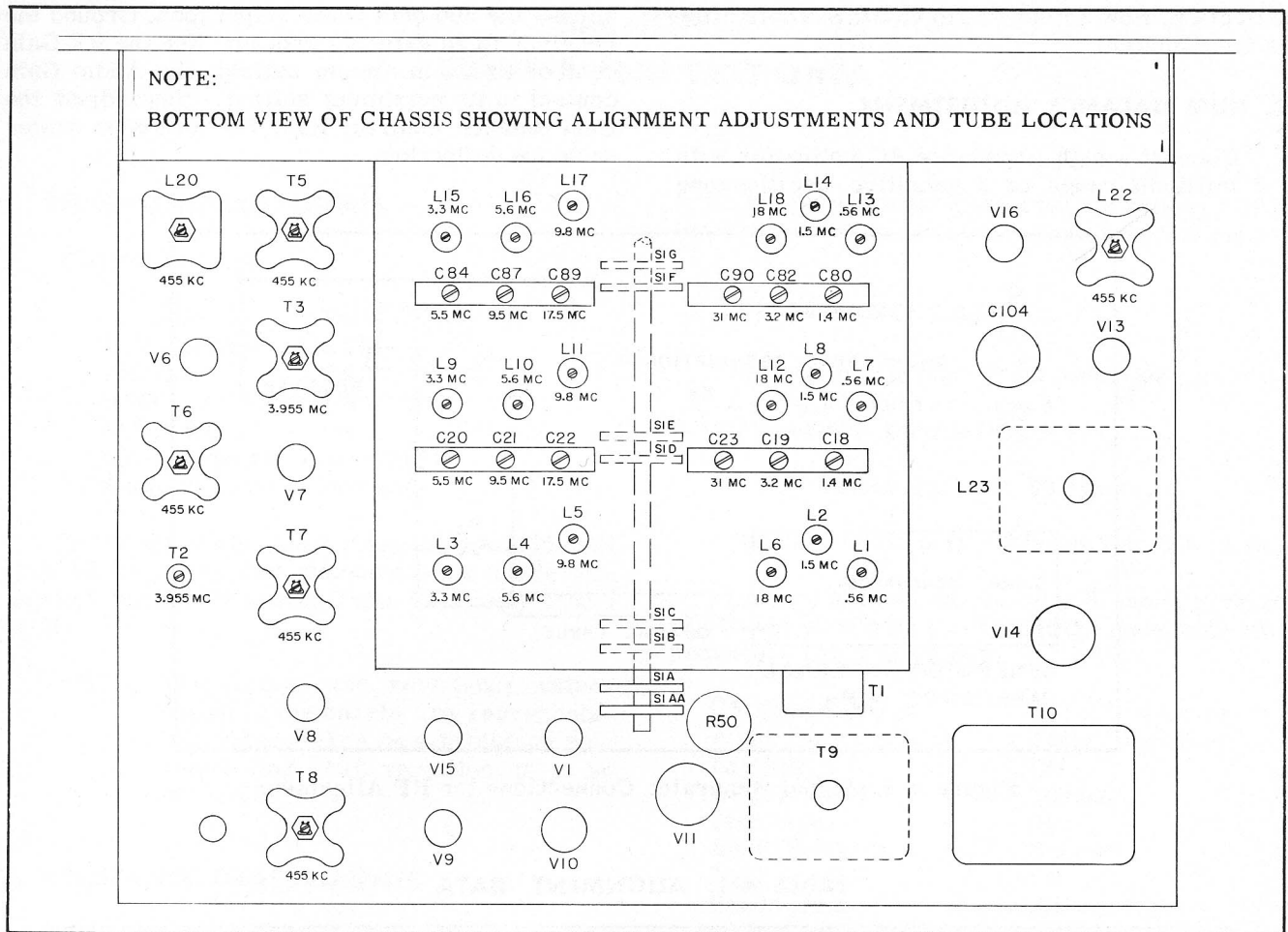

Figure 4-2. Bottom View of Chassis

7. RF ALIGNMENT

The frequencies for the RF alignment and the location for these adjustments are shown in Figure 4-2. The lowest frequency band is aligned first followed by the next higher band. The alignment procedure for the broadcast band will be described so that the remaining bands can be aligned in a similar manner. The signal generator is coupled to the 75 ohm unbalanced antenna terminals of the receiver. See Figure 4-3.

NOTE: The generator output impedance should be subtracted from 75 ohms to obtain the proper antenna dummy resistor. The same receiver control settings should be used as in the case of IF alignment, except that the RF selectivity is reset to non-xtal position and the Bandsread dial locked to 100 on the logging calibration.

Set the Main Tuning dial and the signal generator frequency to .56 Mc. The generator should be modulated 30% at 400 cycles and the output meter connected across the output terminals. Adjust the oscillator slug L13 first, using suf-

ficient signal generator output to obtain meter deflection, followed by L2 and L1 to obtain maximum output. The generator output should be progressively decreased as the receiver sensitivity increases with each tuned circuit. The receiver and signal generator dials are now set to 1.4 Mc; adjust C80, C18 and the Antenna Tune Control, in that order for maximum output. Repeat the above procedure very carefully and until there is no further improvement in sensitivity and frequency calibration. The remaining ranges are aligned in a similar manner and are listed in the accompanying table. The image frequency listed for each signal frequency should be checked to ascertain that the HF oscillator is operating above the signal frequency.

8. S-METER CALIBRATION

Set the range selector to Band 4, AVC on, RF selectivity to non-xtal, RF Gain maximum, signal generator and receiver Main Tuning dial to 7 Mc. Apply 50 microvolts to the receiver antenna terminals, tune the receiver to the signal and peak the Antenna Tune control for maximum

deflection. Now adjust R50 to obtain S-9 deflection on the S-meter.

9. HUM BALANCE ADJUSTMENT

Connect a high impedance AC voltmeter with a 3 millivolt range or a sensitive oscilloscope

across the 600 ohm audio output load. Ground the receiver to an external ground. Set the RF Gain control to its minimum setting, the Audio Gain control to its maximum setting. Now adjust the Hum Balance control, R94, for minimum meter or scope deflection.

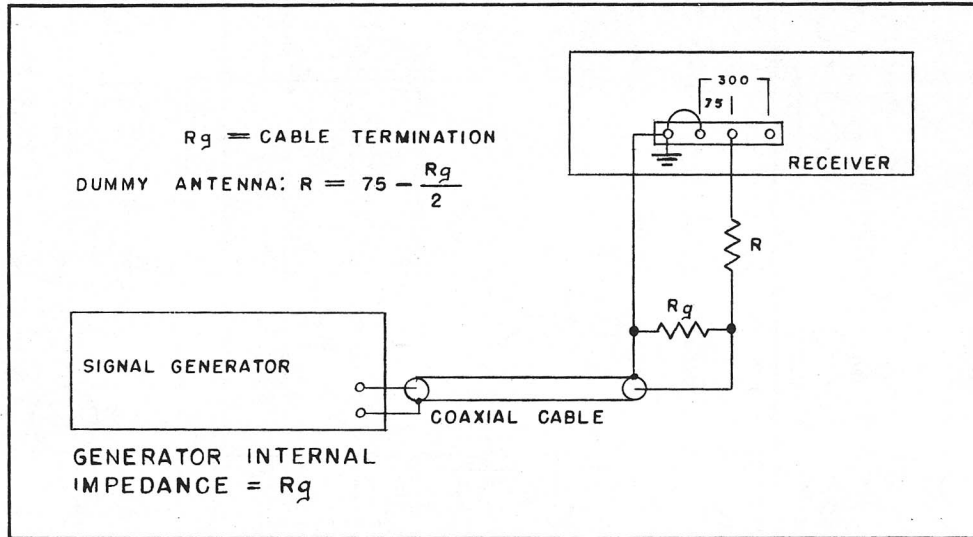

Figure 4-3. Signal Generator Connections for RF Alignment

TABLE 4-1. ALIGNMENT DATA

Band	Signal Generator & Receiver Dial Setting	Adjust For Maximum Output In Order Given			Image Frequency Appears On Signal Generator Dial*
		OSC	MIXER	RF	
1.	.56 Mc	L13	L7	L1	1.47 Mc
	1.4 Mc	C80	C18	C10 Ant Tune	2.31 Mc
2.	1.5 Mc	L14	L8	L2	2.41 Mc
	3.2 Mc	C82	C19	C10 Ant Tune	4.11 Mc
3.	3.3 Mc	L15	L9	L3	4.21 Mc
	5.5 Mc	C84	C20	C10 Ant Tune	6.41 Mc
4.	5.6 Mc	L16	L10	L4	13.51 Mc
	9.5 Mc	C87	C21	C10 Ant Tune	17.41 Mc
5.	9.8 Mc	L17	L11	L5	17.71 Mc
	17.5 Mc	C89	C22	C10 Ant Tune	25.41 Mc
6.	18.0 Mc	L18	L12	L6	25.91 Mc
	31.0 Mc	C90	C23	C10 Ant Tune	38.91 Mc

* Use sufficient generator output.

SECTION V SERVICE AND TEST DATA

1. VOLTAGE MEASUREMENTS

Control Settings:-

RF Gain - Fully Clockwise
 AVC/Manual - AVC
 Limiter - OFF
 BFO - ON
 SEND/Rec. - Rec.
 Range Selector - See Chart
 Audio Selector - Normal

Receiver power cord plugged into 115 volt line, 50-60 cycles and measurements made with Hewlett-Packard Vacuum Tube Voltmeter Model 410B.

NOTE: The voltage and resistance values shown in the charts are representative values taken on a prototype receiver and $\pm 10\%$ variation is to be expected.

2. RESISTANCE MEASUREMENTS

For this measurement, pull the line cord

from the power socket; all control setting left in the same position as in the voltage measurements.

3. PERFORMANCE DATA

Measurements taken from prototype receiver.

4. OPERATING CONDITIONS

Power source 115 volt, 60 cycles.

Standard audio output 2 watts into 600 ohms.

Dummy antenna impedance 75 ohms. (From this value should be subtracted the generator impedance.) See Figure 4-3.

RF Gain Control - Fully Clockwise
 Audio Gain Control - Fully Clockwise
 Limiter - Off
 AVC/Manual - Manual
 Send/Rec. - Rec.
 Audio Selector - Normal
 BFO - Off
 Bandswitch - .54 - 1.4 Mc
 Main Tuning Capacitor - Half Open

TABLE 5-1. VOLTAGE DATA

TUBE	RANGE SELECTOR	SOCKET PIN NUMBERS								
		1	2	3	4	5	6	7	8	9
V1 6AB4	9.4 - 17.8 Mc	130	0	0	6.3V AC	130	0	1.2		
V2 6CB6	1.4 - 3.3 Mc	0	2.5	0		230	135	2.5		
V3 6AU6	1.4 - 3.3 Mc	0	0	0		250	85	3.0		
V4 6BE6	9.4 - 17.8 Mc	-1.3	0	0		250	50	0		
V5 6BA6	1.4 - 3.3 Mc	0	1.5	0		250	50	1.5		
V6 6BA6	↓	-0.4	1.8	6.3V AC	0	200	80	1.8		
V7 6BA6		-0.4	1.8	0	6.3V AC	200	80	1.8		
V8 6BA6		0	1.8	0	6.3V AC	200	80	1.8		

Continued on page 5-2

Continued from page 5-1

TUBE	RANGE SELECTOR	SOCKET PIN NUMBERS								
		1	2	3	4	5	6	7	8	9
V9 6AL5	1.4 - 3.3 Mc ↓ CAL ON	0	-1.5	0	0	-1.5	0	-2.3		
V10 12AX7		-0.45	-0.45	2.0	6.3V AC	6.3V AC	140	-0.6	1.3	
V11 6V6		NC	6.3V AC	240	260	0	NC	0	0	0
V12 6AG5		-0.8	0	0	6.3V AC	140	130	0		
V13 6AG5		-1.5	NC	6.3V AC	0	40	15	0		
V14 5U4-G		NC	300	NC	240V AC	NC	240V AC	300		
V15 OA2		150	NC	NC	NC	NC	NC	0		
V16 6CB6		CAL ON	-45	9.0	6.3V AC	6.3V AC	70	80	0	

NC - CONNECTION

TABLE 5-2. RESISTANCE DATA

TUBE	RANGE SELECTOR	SOCKET PIN CONNECTIONS								
		1	2	3	4	5	6	7	8	9
V1 6AB4	9.4 - 17.8 Mc	50 K	0	0	0	50 K	3 M	220		
V2 6CB6	1.4 - 3.3 Mc	3 M	260	0	0	50 K	100 K	260		
V3 6AU6	1.4 - 3.3 Mc	2.2 M	0	0	0	50 K	200 K	3 K		
V4 6BE6	9.4 - 17.8 Mc	15 K	0	0	0	50 K	70 K	47		
V5 6BA6	1.4 - 3.3 Mc	2	510	0	0	50 K	180 K	510		
V6 6BA6		4 M	220	0	0	50 K	140 K	220		
V7 6BA6		3 M	220	0	0	40 K	35 K	220		
V8 6BA6		22	220	0	0	55 K	100 K	220		
V9 6AL5		0	500 K	2	0	500 K	0	750 K		
V10 12AX7		1.2 M	1.2 M	4.5 K	0	0	100 K	8.2 M	200	0
V11 6V6		NC	0	50 K	50 K	470 K	0	0		
V12 6AG5		22 K	0	0		45 K	NC	0		
V13 6AG5	47 K	0	0		130 K	65 K	0			
V14 5U4-G			50 K	NC	70	NC	100 K	50 K		
V15 OA2		50 K				50 K	70			
V16 6CB6	CAL ON	.5 M	6.8 K	0	0	50 K	50 K	0		

K=1,000

M=1,000,000

TABLE 5-3. IF BANDWIDTH AT 455 KC

BANDWIDTH CONTROL SETTING		6 DB 2 X INPUT	60 DB 1000 INPUT
*	.25 Kc (Xtal Phase-0)	.15 - .35 Kc	9 - 4 Kc
*	.5 Kc (Xtal Phase-0)	.4 - .6 Kc	12.0 Kc
*	1.0 Kc (Xtal Phase-0)	.7 - 1.1 Kc	12.4 Kc
**	1.5 Kc (Xtal Phase-0)	.9 - 1.6 Kc	12.8 Kc
**	2.0 Kc (Xtal Phase-0)	1.5 - 2.3 Kc	13.6 Kc
**	Non-Xtal	6 - 8 Kc	24 Kc

* Signal Generator modulated 100 cycles at 30%.

** Signal Generator modulated 400 cycles at 30%.

IF Sensitivity at first mixer grid V3, non-xtal.

455 Kc --- 25 to 50 microvolts.

3.955 Mc --- 20 to 50 microvolts.

TABLE 5-4. RF SENSITIVITY

30% Modulation -- 400 Cycles				
BAND	FREQ. MCS.	MICROVOLT INPUT FOR 2 WATT OUTPUT	MICROVOLT INPUT FOR 10DB SIGNAL TO NOISE RATIO	IMAGE RATIO
1	.56	1.8	.90	25 K
	1.00	3	.90	
	1.40	4.0	1.1	
2	1.50	0.75	.6	15 K
	2.40	1.2	.65	2.2 K
	3.20	1.2	.9	1.2 K
3	3.30	1.0	.58	3.5 K
	4.40	1.0	.60	1.5 K
	5.50	1.0	.65	1 K
4	5.60	.70	.7	20 K
	7.40	.70	.6	10 K
	9.50	.80	.8	3 K
5	9.80	.65	.6	16 K
	13.50	.65	.9	5 K
	17.5	.90	.9	1.2 K
6	18.0	.70	.6	12 K
	24.0	.65	.8	3.5 K
	30.0	.90	.8	1 K

Data taken from prototype receiver.

Compared to H Q-160: worse base fidelity, better Fochel fidelity.

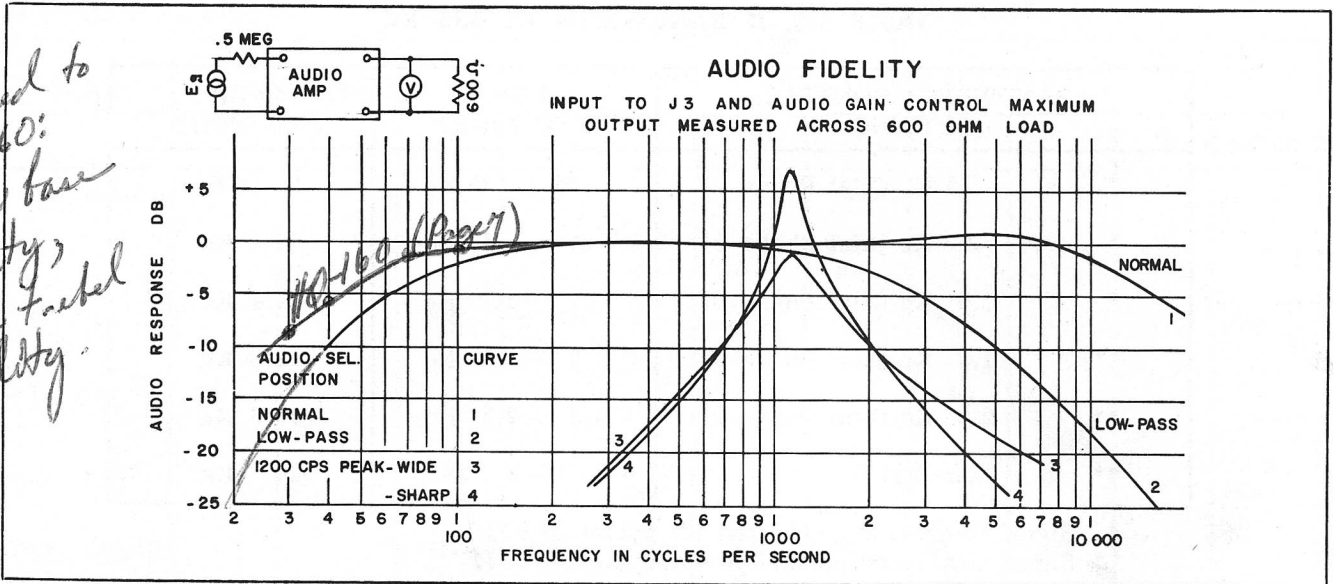

Figure 5-1. Audio Fidelity Curves

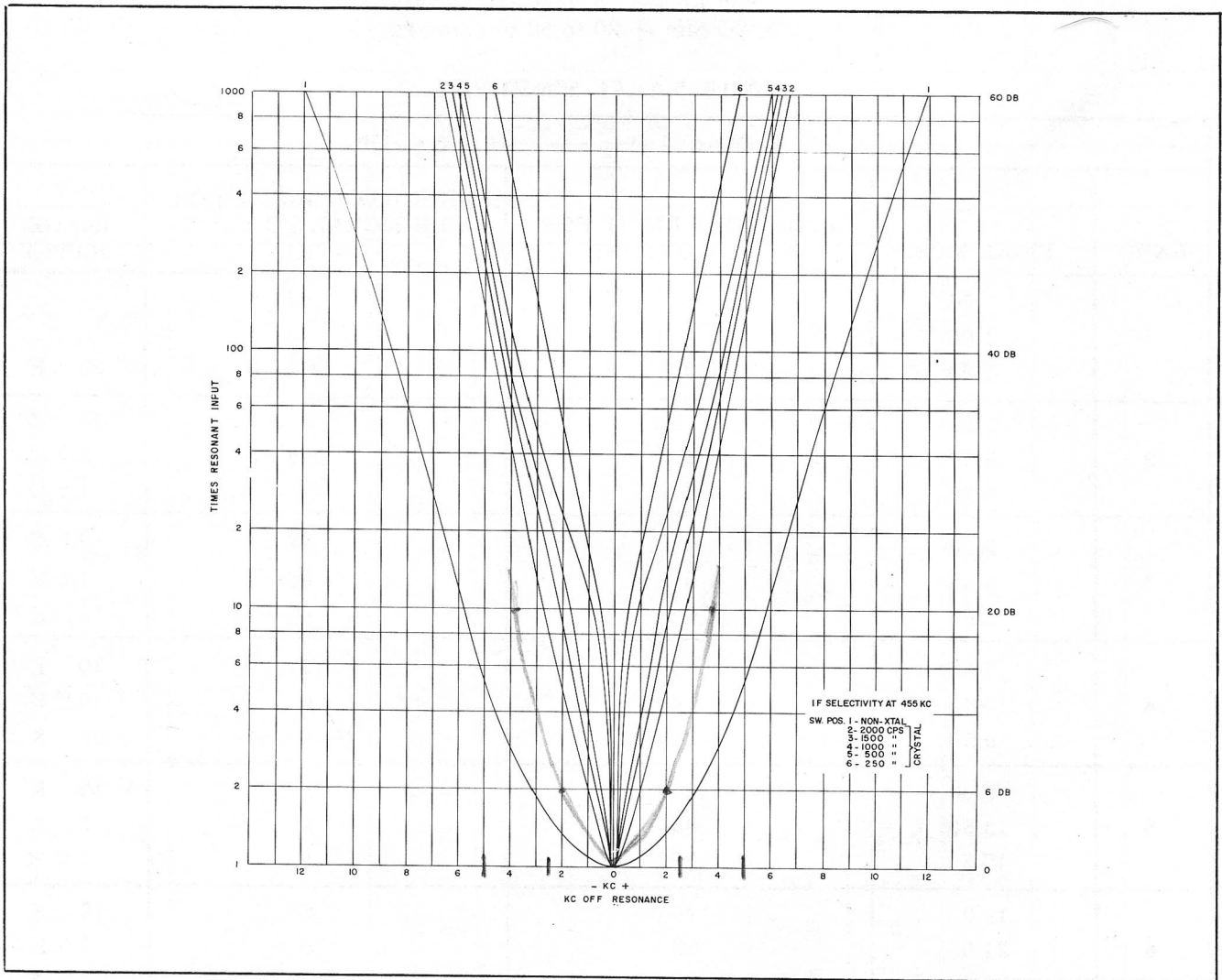

Figure 5-2. IF Selectivity Curves

ADDENDUM

The purpose of this addendum is to create a better understanding of the receiver and thereby permit a more efficient operation.

Added paragraph 10 of Section 2 is as follows:

10. CALIBRATOR

The crystal calibrator is a source of 100 Kc marker signals of sufficient magnitude to check the dial calibration and provides 100 Kc harmonics up to 35 Mc.

Add to paragraph 1 sub-paragraph 4 Section 3 the following:

<u>Band (meters)</u>	<u>Freq. Mc</u>	<u>Total Spread degrees</u>	<u>Total Divisions</u>	<u>Kc/Div</u>
160	1.8 - 2.0	272	40	5
80	3.5 - 4.0	215	50	10
40	7. - 7.3	144	30	10
20	14.0 -14.35	167	35	10
15	21.0 -21.45	100	22	20
11	26.95-27.54	56	11	50
10	28.0 - 29.7	132	34	50

Added paragraph 10 and 11 of Section 4 is as follows:

10. CALIBRATOR FREQUENCY ADJUST

With an antenna connected to the receiver and the BFO "ON", tune in WWV at 2.5 Mc, 5 Mc or 10 Mc. Set the CAL-OFF switch to CAL. The frequency adjust control (C106) should then be varied until zero beat is accomplished. The calibrator is now in resonance with WWV, National Bureau of Standards.

11. RECEIVER CALIBRATION

Set the controls as follows: BFO "ON"; AVC-Manual to "AVC"; BANDSPREAD dial at 100 on the log scale. Turn the MAIN TUNING dial through its range. A zero beat will be heard every 100 Kc. This may be done on any of the six MAIN TUNING bands. The BANDSPREAD dial is checked in a similar manner except that the MAIN TUNING dial is first set at the proper band set point on its dial. The BANDSPREAD dial may then be tuned and at every 100 Kc a zero beat will be obtained.

5. ELECTRICAL PARTS LIST

SYM.	DESCRIPTION	FUNCTION & LOCATION	TMC PART NO.
C1	CAPACITOR, fixed: ceramic; .01 mfd, (GMC) 500 wvdc, disc. type.	Cath. Bypass V1	CC-100-16
C2	CAPACITOR, fixed: ceramic; .01 mfd, (GMC) 500 wvdc, disc. type.	AVC Bypass V1	CC-100-16
C3	CAPACITOR, fixed: ceramic; 5 mmfd, ± 0.25 mmfd, 500 wvdc.	Interstage Coupling L4	CC21SL050C
C4	CAPACITOR, fixed: ceramic; 5 mmfd, ± 0.25 mmfd, 500 wvdc.	Interstage Coupling L5	CC21SL050C
C5	CAPACITOR, fixed: ceramic; 47 mmfd, $\pm 10\%$, 500 wvdc,	Interstage Coupling L6	CC21SL470K
C6	CAPACITOR, fixed: ceramic; .01 mfd, (GMC) 500 wvdc, disc. type.	B+ Bypass S1B	CC-100-16
C7	CAPACITOR, fixed: ceramic; .01 mfd, (GMC) 500 wvdc, disc. type.	AVC Bypass L6	CC-100-16
C8A, B,C	CAPACITOR, variable: air; 3 sections; #1 8-9.7 mmfd, #2 8-9.7 mmfd, #3 7-7.5 mmfd.	Band Spread	CB-131
C9A, B,C	CAPACITOR, variable: air; 3 sections; #1 8.5-135 mmfd, #2 10.5-189 mmfd.	Main Tuning	CB-130
C10	CAPACITOR, variable, air; 2.3-15 mmfd.	Ant. Tuning	CT-104-2
C11	CAPACITOR, fixed: ceramic; .01 mfd, (GMC) 500 wvdc, disc. type.	Cathode Bypass V2	CC-100-16
C12	CAPACITOR, fixed: ceramic; .01 mfd, (GMC) 500 wvdc, disc. type.	Screen Bypass V2	CC-100-16
C13	CAPACITOR, fixed: mica; 1600 mmfd, $\pm 1\%$, 500 wvdc; char D.	RF Plate Tank L7	CM109D1601F
C14	CAPACITOR, fixed: mica; 270 ohms, $\pm 2\%$, 500 wvdc; char. C.	RF Plate Tank L8	CM15C271G
C15	CAPACITOR, fixed: ceramic; 5 mmfd, ± 0.25 mmfd; 500 wvdc.	Interstage Coupling L11	CC21SL050C
C16	CAPACITOR, fixed: ceramic; .01 mfd, (GMC) 500 wvdc, disc. type.	B+ Bypass S1D	CC-100-16
C17	CAPACITOR, fixed: ceramic; .01 mfd, (GMC) 500 wvdc, disc. type.	B+ Bypass S1D	CC-100-16
C18	CAPACITOR, variable: mica; 2.7-30 mmfd, #1 section.	Mixer Trimmer L7	CX-101

SYM.	DESCRIPTION	FUNCTION & LOCATION	TMC PART NO.
C19	CAPACITOR, variable: mica; 2.7-30 mmfd, #2 section.	Mixer Trimmer L8	
C20	CAPACITOR, variable: mica; 2.7-30 mmfd, #3 section.	Mixer Trimmer L9	
C21	CAPACITOR, variable: mica; 2.7-30 mmfd, #1 section.	Mixer Trimmer L10	CX-101
C22	CAPACITOR, variable: mica; 2.7-30 mmfd, #2 section.	Mixer Trimmer L11	
C23	CAPACITOR, variable: mica; 2.7-30 mmfd, #3 section.	Mixer Trimmer L12	
C24	CAPACITOR, fixed: ceramic; .01 mfd, (GMC) 500 wvdc, disc. type.	Grid Return Bypass L12	CC-100-16
C25	CAPACITOR, fixed: ceramic; .01 mfd, (GMC) 500 wvdc, disc. type.	Cathode Bypass V3	CC-100-16
C26	CAPACITOR, fixed: ceramic; .01 mfd, (GMC) 500 wvdc, disc. type.	Screen Bypass V3	CC-100-16
C27	CAPACITOR, fixed: mica; 180 mmfd, $\pm 2\%$; 500 wvdc, char D.	IF Tank P/O T3	CM109D1800G
C28	CAPACITOR, fixed: mica; 1000 mmfd, $\pm 2\%$; 500 wvdc.	IF Tank P/O T4	CM109D1001G
C29	CAPACITOR, fixed: ceramic; .01 mfd, (GMC) 500 wvdc, disc. type.	B+ Bypass T4	CC-100-16
C30	CAPACITOR, fixed: ceramic; .01 mfd, (GMC) 500 wvdc, disc. type.	B+ Bypass V4	CC-100-16
C31	CAPACITOR, fixed: ceramic; .01 mfd, (GMC) 500 wvdc, disc. type.	Screen Bypass V4	CC-100-16
C32	CAPACITOR, fixed: ceramic; 120 mmfd, $\pm 10\%$, 500 wvdc.	Grid Coupling V4	CC-101-4
C33	CAPACITOR, fixed: mica; 220 mmfd, $\pm 2\%$, 500 wvdc, char D.	Osc. Tank V4	CM109D2200G
C34	CAPACITOR, fixed: mica; 200 mmfd, $\pm 2\%$, 500 wvdc, char D.	IF Tank P/O T2	CM109D2000G
C35	CAPACITOR, fixed: mica; 200 mmfd, $\pm 2\%$, 500 wvdc, char D.	IF Tank P/O T2	CM109D2000G
C36	CAPACITOR, fixed: ceramic; .01 mfd, (GMC) 500 wvdc, disc. type.	B+ Bypass V5	CC-100-16
C37	CAPACITOR, fixed: ceramic; .01 mfd, (GMC) 500 wvdc, disc. type.	Screen Bypass V5	CC-100-16

SYM.	DESCRIPTION	FUNCTION & LOCATION	TMC PART NO.
C38	CAPACITOR, fixed: ceramic; .01 mfd, (GMC) 500 wvdc, disc. type.	B+ Bypass S1A	CC-100-16
C39	CAPACITOR, fixed: mica; 220 mmfd, $\pm 2\%$, 500 wvdc, char D.	IF Tank P/O T5	CM109D2200G
C40	CAPACITOR, fixed: ceramic; .01 mfd, (GMC) 500 wvdc, disc. type.	B+ Bypass T5	CC-100-16
C41	CAPACITOR, fixed: mica; 2400 mmfd, $\pm 2\%$, 500 wvdc, char D.	IF Tank P/O T5	CM109D2401G
C42	CAPACITOR, variable: air, 2.8-11 mmfd, one section.	Xtal Phasing Y1	CT-105-1
C43	CAPACITOR, fixed: mica; 5 mmfd, $\pm 20\%$, 500 wvdc, char C.	Xtal Filter	CM15C050M
C44	CAPACITOR, fixed: mica; 300 mmfd, $\pm 2\%$, 500 wvdc, char D.	Xtal Filter Load	CM109D3000G
C45	CAPACITOR, fixed: ceramic; .01 mfd, (GMC) 500 wvdc, disc. type.	Grid Coupling V6	CC-100-16
C46	CAPACITOR, fixed: ceramic; .01 mfd, (GMC) 500 wvdc, disc. type.	Cathode Bypass V6	CC-100-16
C47	CAPACITOR, fixed: ceramic; .01 mfd, (GMC) 500 wvdc, disc. type.	AVC Return V6	CC-100-16
C48	CAPACITOR, fixed: ceramic; .01 mfd, (GMC) 500 wvdc, disc. type.	Screen Bypass V6	CC-100-16
C49	CAPACITOR, fixed: mica; 1000 mmfd, $\pm 2\%$, 500 wvdc, char D.	IF Tank P/O T6	CM109D1001G
C50	CAPACITOR, fixed: ceramic; .01 mfd, (GMC) 500 wvdc, disc. type.	B+ Bypass T6	CC-100-16
C51	CAPACITOR, fixed: mica; 1000 mmfd, $\pm 2\%$, 500 wvdc, char D.	IF Tank P/O T6	CM109D1001G
C52	CAPACITOR, fixed: ceramic; .01 mfd, (GMC) 500 wvdc, disc. type.	AVC Bypass T6	CC-100-16
C53	CAPACITOR, fixed: ceramic; .01 mfd, (GMC) 500 wvdc, disc. type.	Cathode Bypass V7	CC-100-16
C54	CAPACITOR, fixed: ceramic; .01 mfd, (GMC) 500 wvdc, disc. type.	Screen Bypass V7	CC-100-16
C55	CAPACITOR, fixed: ceramic; 1000 mmfd, $\pm 2\%$, 500 wvdc, char D.	IF Tank P/O T7	CM109D1001G
C56	CAPACITOR, fixed: ceramic; .01 mfd, (GMC) 500 wvdc, disc. type.	B+ Bypass V7	CC-100-16
C57	CAPACITOR, fixed: ceramic; 47 mmfd, $\pm 10\%$, 500 wvdc.	IF Output V8	CC21SL470K

SYM.	DESCRIPTION	FUNCTION & LOCATION	TMC PART NO.
C58	CAPACITOR, fixed: ceramic; 1000 mmfd, $\pm 2\%$, 500 wvdc, char D.	IF Tank P/O T7	CM109D1001G
C59	CAPACITOR, fixed: ceramic; 15 mmfd, $\pm 5\%$, 500 wvdc.	BFO Injection T7	CC21SL150J
C60	CAPACITOR, fixed: ceramic; .01 mfd, (GMC) 500 wvdc, disc type.	Cathode Bypass V8	CC-100-16
C61	CAPACITOR, fixed: ceramic; .01 mfd, (GMC) 500 wvdc, disc type.	Screen Bypass V8	CC-100-16
C62	CAPACITOR, fixed: ceramic; 1000 mmfd, $\pm 2\%$, 500 wvdc, char D.	IF Tank P/O T8	CM109D1001G
C63	CAPACITOR, fixed: ceramic; .01 mfd, (GMC) 500 wvdc, disc type.	B+ Bypass T8	CC-100-16
C64	CAPACITOR, fixed: ceramic; 1000 mmfd, $\pm 2\%$, 500 wvdc, char D.	IF Tank P/O T8	CM109D1001G
C65	CAPACITOR, fixed: ceramic; 220 mmfd, $\pm 10\%$, 500 wvdc.	RF Filter T8	CC-101-3
C66	CAPACITOR, fixed: ceramic; 220 mmfd, $\pm 10\%$, 500 wvdc.	RF Filter T8	CC-101-3
C67	CAPACITOR, fixed: ceramic; .01 mfd, (GMC) 500 wvdc, disc. type.	Noise Limiter Bypass V9	CC-100-16
C68	CAPACITOR, fixed: ceramic; 51 mmfd, $\pm 2\%$, 500 wvdc.	AVC Coupling V9	CC21SL510G
C69	CAPACITOR, fixed: moulded plastic; .05 mfd, $+40 -20\%$ 400 wvdc.	AVC Time Constant V10	CN-100-3
C70	CAPACITOR, fixed: ceramic; .01 mfd, (GMC) 500 wvdc, disc. type.	Cathode Bypass V10	CC-100-16
C71	CAPACITOR, fixed: ceramic; .01 mfd, (GMC) 500 wvdc, disc. type.	Grid Coupling V10	CC-100-16
C72	CAPACITOR, fixed: ceramic; 5000 mfd, (GMC) 500 wvdc, disc. type.	Low Pass Filter	CC-100-15
C73	CAPACITOR, fixed: ceramic; .02 mfd, (GMC) 500 wvdc, disc. type.	Audio Peak Filter	CC-100-24
C74	CAPACITOR, fixed: ceramic; 5000 mmfd, (GMC) 500 wvdc, disc. type.	Audio Peak Filter	CC-100-15
C75	CAPACITOR, fixed: ceramic; .01 mfd, (GMC) 500 wvdc, disc. type.	Plate Grid Coupling V11	CC-100-16
C76	CAPACITOR, fixed: electrolytic; 25 mfd, $\pm 10\%$, 500 wvdc.	Cathode Bypass V11	CE-100

SYM.	DESCRIPTION	FUNCTION & LOCATION	TMC PART NO.
C77	CAPACITOR, fixed: electrolytic; 20 mfd, 250 wvdc.	B+ Bypass V14	CE-103-5
C78	CAPACITOR, fixed: ceramic; 47 mmfd, +5%, 500 wvdc.	Osc. Injection HFO S1F	CC21UJ470J
C79	CAPACITOR, fixed: mica; 430 mmf, ±1%, 500 wvdc, char D.	OSC. Padder L13	CM20D431F
C80	CAPACITOR, variable: air; 2.7-19.6 mmfd, 500 wvdc.	Osc. Trimmer L13	CB-122-4
C81	CAPACITOR, fixed: mica; 1090 mmfd, ±1%, 500 wvdc.	Osc. Padder L14	CM20D1091F
C82	CAPACITOR, variable: air; 2.7-19.6 mmfd, 500 wvdc.	Osc. Trimmer L14	CB-122-4
C83	CAPACITOR, fixed: ceramic; 750 mmfd, ±5%, 500 wvdc.	Osc. Padder L15	CC45UJ751J
C84	CAPACITOR, variable: air; 2.7-19.6 mmfd, 500 wvdc.	Osc. Trimmer L15	CB-122-4
C85	CAPACITOR, fixed: ceramic; 91 mmfd, ±5%, 500 wvdc.	Osc. Padder L16	CC35CG910J
C86	CAPACITOR, fixed: ceramic; 4.7 mmfd, ±5%, 500 wvdc.	Osc. Tank L16	CC20UJ4R7C
C87	CAPACITOR, variable: air; 2.7-19.6 mmfd, 500 wvdc.	Osc. Trimmer L16	CB-122-4
C88	CAPACITOR, fixed: ceramic; 330 mmfd, ±5%, 500 wvdc.	Osc. Padder L17	CC45SH331J
C89	CAPACITOR, variable: air; 2.7-19.6 mmfd, 500 wvdc.	Osc. Trimmer L17	CB-122-4
C90	CAPACITOR, variable: air; 2.7-19.6 mmfd, 500 wvdc.	Osc. Trimmer L18	CB-122-4
C91	CAPACITOR, fixed: ceramic; 4.7 mmfd, ±5%, 500 wvdc.	Osc. Tank L18	CC20UJ4R7C
C92	CAPACITOR, fixed: ceramic; 390 mmfd, ±5%, 500 wvdc.	Osc. Padder L18	CC45SH391J
C93	CAPACITOR, fixed: ceramic; 47 mmfd, ±5%, 500 wvdc.	Grid Coupling V12	CC21UJ470J
C94	CAPACITOR, fixed: ceramic; .01 mfd, (GMC) 500 wvdc, disc. type.	Plate Return V12	CC-100-16
C95	CAPACITOR, fixed: ceramic; .01 mfd, (GMC) 500 wvdc, disc. type.	Screen Bypass V12	CC-100-16
C96	CAPACITOR, fixed: ceramic; .01 mfd, (GMC) 500 wvdc, disc. type.	B+ Bypass V12	CC-100-16

SYM.	DESCRIPTION	FUNCTION & LOCATION	TMC PART NO.
C97	CAPACITOR, fixed: moulded plastic; .05 mfd, +40 -20%, 400 wvdc.	RF Gain Bypass R81	CN-100-3
C98	CAPACITOR, fixed: mica; 1500 mmfd, ±2%, 500 wvdc.	BFO Tank P/O L22	CM20D152G
C99	CAPACITOR, variable: air, 2.9-35 mmfd.	BFO Pitch P/O L22	CT-104-4
C100	CAPACITOR, fixed: ceramic; 220 mmfd, ±10%, 500 wvdc.	Grid Coupling P/O L22	CC-101-3
C101	CAPACITOR, fixed: ceramic; .01 mfd, (GMC) 500 wvdc, disc. type.	Screen Bypass V13	CC-100-16
C102	CAPACITOR, fixed: ceramic; .01 mfd, (GMC) 500 wvdc, disc. type.	B+ Bypass V13	CC-100-16
C103	CAPACITOR, fixed: ceramic; .01 mfd, (GMC) 500 wvdc, disc. type.	AC Line Bypass X1	CC-100-16
C104 A,B	CAPACITOR, fixed: electrolytic; 40-40 mfd, 450 wvdc.	B+ Filter V14	CE-102
C105 A,B	CAPACITOR, fixed: ceramic; .01 mfd, each section, (GMC) 500 wvdc, disc type.	Filament Bypass V6	CC-100-23
C106	CAPACITOR, variable: air dielectric; one section, nineteen plates 3.2 to 50 mmfd,, 500 wvdc.	Xtal Adj.	CT-104-3
C107	CAPACITOR, fixed: ceramic; .01 mfd, (GMC) 500 wvdc, disc type.	Filament Bypass V12	CC-100-16
C108	CAPACITOR, fixed: ceramic; .01 mfd, (GMC) 500 wvdc, disc. type.	AC Line Bypass F1	CC-100-16
C109	CAPACITOR, fixed: ceramic; 5 mmfd, ±0.25 mmfd, 500 wvdc.	Interstage Coupling L8	CC21SL050C
C110	CAPACITOR, fixed: ceramic; .01 mfd, (GMC) 500 wvdc, disc. type.	DC Blocking V1	CC-100-16
C111	CAPACITOR, fixed: ceramic; .01 mfd, (GMC) 500 wvdc, disc. type.	B+ Bypass S1A	CC-100-16
C112	CAPACITOR, fixed: ceramic; .01 mfd, (GMC) 500 wvdc, disc. type.	B+ Bypass S1A	CC-100-16
C113	CAPACITOR, fixed: ceramic; .01 mfd, (GMC) 500 wvdc, disc. type.	B+ Bypass S1A	CC-100-16
C114	CAPACITOR, fixed: ceramic; 6.8 mmfd, ±5%, 500 wvdc.	Osc. Tank L15	CC20UJ6R8D
C115	CAPACITOR, fixed: ceramic; 22 mmfd, ±10%, 500 wvdc.	Interstage Coupling L12	CC21SL220K

SYM.	DESCRIPTION	FUNCTION & LOCATION	TMC PART NO.
C116	CAPACITOR, fixed: ceramic; .01 mfd, (GMC) 500 wvdc, disc. type.	Grid Bias V10	CC-100-16
C117	CAPACITOR, fixed: mica; 150 mmfd, $\pm 2\%$, 500 wvdc.	Intermod. Filter V1	CM15E151G
C118	CAPACITOR, fixed: mica; 150 mmfd, $\pm 2\%$, 500 wvdc.	Intermod. Filter V1	CM15E151G
C119	CAPACITOR, fixed: ceramic; .01 mfd, (GMC) 500 wvdc, disc. type.	Filament Bypass V12	CC-100-16
C120	CAPACITOR, fixed: ceramic; .01 mfd, (GMC) 500 wvdc, disc. type.	B+ Bypass L4	CC-100-16
C121	CAPACITOR, fixed: ceramic; .01 mfd, (GMC) 500 wvdc, disc. type.	B+ Bypass V12	CC-100-16
C122	CAPACITOR, fixed: ceramic; 1.0 mmfd, $\pm .5$ mmfd, 500 wvdc.	Temp. Compensator V12	CC-101-8
C123	CAPACITOR, fixed: ceramic; 2.2 mmfd, $\pm .5$ mmfd, 500 wvdc.	Temp. Compensator S1G	CC-101-9
C124	CAPACITOR, fixed: mica; 1000 mmfd, $\pm 10\%$, 500 wvdc.	DC Blocking S1F	CM20B102K
C125	CAPACITOR, fixed: ceramic; 10 mmfd, $\pm 5\%$, 500 wvdc.	Osc. Tank L14	CC20UJ100J
C126	CAPACITOR, fixed: ceramic; 6.8 mmfd, $\pm 5\%$, 500 wvdc.	Osc. Tank L17	CC20RH4R7C
C127	CAPACITOR, fixed: ceramic; 750 mmfd, $\pm 5\%$, 500 wvdc.	Osc. Padder L15	CC45UJ751J
C128	CAPACITOR, fixed: ceramic; 180 mmfd, $\pm 5\%$, 500 wvdc.	Osc. Padder L15	CC35UJ181J
C129	CAPACITOR, fixed: ceramic; 220 mmfd, $\pm 5\%$, 500 wvdc.	Osc. Padder L16	CC45SH221J
C130	CAPACITOR, fixed: ceramic; 100 mmfd, $\pm 5\%$, 500 wvdc.	Osc. Padder L17	CC32SH101J
C131	CAPACITOR, fixed: ceramic; 390 mmfd, $\pm 5\%$, 500 wvdc.	Osc. Padder L18	CC45TH391J
C132	CAPACITOR, fixed: ceramic; .01 mfd, (GMC) 500 wvdc, disc. type.	Filament Bypass V3	CC-100-16
C133	CAPACITOR, fixed: ceramic; .01 mfd, (GMC) 500 wvdc, disc. type.	Filament Bypass V3	CC-100-16
C134	CAPACITOR, fixed: ceramic; .01 mfd., $\pm 80 -20\%$, 500 wvdc; disc type.	Cathode Bias Cap., V16	CC-100-16

SYM.	DESCRIPTION	FUNCTION & LOCATION	TMC PART NO.
C135	CAPACITOR, fixed: ceramic; .01 mfd., +80%-20%, 500 wvdc; disc type.	Screen Coupling Cap., V16	CC-100-16
C136	CAPACITOR, fixed: ceramic; 150 mmfd., ±10%, 500 wvdc.	Screen Bypass Cap. V16	CC-101-2
C137	CAPACITOR, fixed: ceramic; 8 mmfd., ±2%, 500 wvdc.	Xtal Cal. Output Coupling	CC21SL080G
C138	CAPACITOR, fixed: mica; 110 mmfd., ±2%, char. E; 500 wvdc.	P/O Low Pass Filter	CM15E111G
C139	CAPACITOR, fixed: mica; 56 mmfd., ±2%, char. E; 500 wvdc.	P/O Low Pass Filter	CM15E560G
C140	CAPACITOR, fixed: mica; 56 mmfd., ±2%, char. E; 500 wvdc.	P/O Low Pass Filter	CM15E560G
C141	CAPACITOR, fixed: mica; 110 mmfd., ±2%, char. E; 500 wvdc.	P/O Low Pass Filter	CM15E111G
C142	CAPACITOR, fixed: mica; 68 mmfd., ±2%, char. E; 500 wvdc.	P/O Low Pass Filter	CM15E680G
C143	CAPACITOR, fixed: mica; 68 mmfd., ±2%, char. E; 500 wvdc.	P/O Low Pass Filter	CM15E680G
E1	STRIP, terminal: feed-thru; four 6-32 binder head machine screws with solder lugs.	Terminal Connections	TM-116-4
E2	STRIP, terminal: feed through; five 6-32 binder head screws with solder lugs.	Term. Connections	TM-116-5
F1	FUSE, cartridge: 2 amp., AGC type.	Line Fuse	FU-100-2
I1	LAMP, incandescent: 6-8 volts; 250 ma DC, bayonet base, frosted.	Dial Light	BI-101-44 (AF)
I2	LAMP, incandescent: 6-8 volts; 250 ma DC, bayonet base, frosted.	Dial Light	BI-101-44 (AF)
I3	LAMP, incandescent: 6-8 volts; 250 ma DC, bayonet base.	Meter Light	BI-101-44
J1 A,B	JACK, tip: electrical; dual contact; phono type.	IF Output Phono Input	JJ-144
J2	JACK, telephone: normally closed.	Phones	JJ-132
J3	RECEPTACLE, female: 2 prong; 125 v, at 15 a; 250 v, at 10 a.	115 v. Source	JJ-145

SYM.	DESCRIPTION	FUNCTION & LOCATION	TMC PART NO.
J4	CONNECTOR, receptacle: electrical; female; two prong; polarized; one 5/32 in. dia. pin hole and one 1/8 in. dia. pin hole.	Relay	JJ-146
L1	TRANSFORMER, RF: tuned; .535 to 1.45 Mc; primary, 17.5 microhenries, ± 8 microhenries, Q=45; secondary, 195 microhenries, ± 10 microhenries, Q=60.	Antenna Coil, Band 1	A-892
L2	TRANSFORMER, RF: tuned; 1.43 to 3.3 Mc; primary, 32.5 microhenries, ± 1.6 microhenries, Q=40; secondary, 27.5 microhenries, ± 1.4 microhenries, Q=90.	Antenna Coil, Band 2	A-897
L3	TRANSFORMER, RF: tuned; 3.2 to 5.6 Mc; primary, 190 microhenries, ± 9.5 microhenries, Q=50; secondary, 9.7 microhenries, $\pm .048$ microhenries, Q=85.	Antenna Coil, Band 3	A-898
L4	COIL, RF: tuned; 5.4 to 9.6 Mc; 3.4 microhenries, $\pm 5\%$, Q=120.	Antenna Coil, Band 4	A-901
L5	COIL, RF: tuned; 9.4 to 17.8 Mc; 1.1 microhenries, $\pm 5\%$, Q=110.	Antenna Coil, Band 5	A-900
L6	TRANSFORMER, RF: tuned; 17.3 to 31.5 Mc; .3 microhenries, Q=115; tapped at 1-1/4 turns.	Antenna Coil, Band 6	A-905
L7	TRANSFORMER, RF: tuned; .535 to 1.45 Mc; primary, 280 microhenries, ± 14 microhenries, Q=50; secondary, 195 microhenries, ± 10 microhenries, Q=60.	RF Coil, Band 1	A-961
L8	TRANSFORMER, RF: tuned: 1.43 to 3.3 Mc; primary, 94 microhenries, ± 5 microhenries, Q=40; secondary, 27.5 microhenries, ± 1.4 microhenries, Q=90.	RF Coil, Band 2	A962
L9	TRANSFORMER, RF: tuned: 3.2 to 5.6 Mc; primary, 9 microhenries, $\pm 5\%$, Q=55; secondary, 9.7 microhenries, $\pm 5\%$, Q=85.	RF Coil, Band 3	A-963
L10	TRANSFORMER, RF: tuned; 5.4 to 9.6 Mc; primary, 5 microhenries, $\pm .25$ microhenries, Q=78; secondary, 3.4 microhenries, $\pm .2$ microhenries, Q=120.	RF Coil, Band 4	A-964

SYM.	DESCRIPTION	FUNCTION & LOCATION	TMC PART NO.
L11	COIL, RF: tuned: 9.4 to 17.8 Mc; 1.1 microhenries, ± 0.05 microhenries, $Q=115$.	RF Coil, Band 5	A-965
L12	TRANSFORMER, RF: tuned; 17.3 to 31.5 Mc; .3 microhenries, $Q=115$.	RF Coil, Band 6	A-966
L13	TRANSFORMER, RF: tuned; .990 to 1.905 Mc; 111 microhenries, ± 5 microhenries, $Q=95$, tapped at 71 microhenries, ± 4 microhenries, $Q=85$.	Osc. Coil, Band 1	A-894
L14	TRANSFORMER, RF: tuned; 1.885 to 3.755 Mc; 20.5 microhenries, ± 1 microhenry, $Q=100$, ± 5 , tapped at 13.5 microhenries, ± 6 microhenries, $Q=90$, ± 5 .	Osc. Coil, Band 2	A-896
L15	TRANSFORMER, RF: tuned; 3.655 to 6.055 Mc; 8.2 microhenries, ± 4 microhenries, $Q=100$, ± 8 ; tapped at 5.5 microhenries, ± 2.5 microhenries, $Q=85$, ± 6 .	Osc. Coil, Band 3	A-899
L16	TRANSFORMER, RF: tuned: 9.355 to 13.555 Mc; 1.66 microhenries, ± 0.08 microhenries, $Q=80$, tapped at 1.12 microhenries, ± 0.05 microhenries, $Q=75$.	Osc. Coil, Band 4	A-903
L17	TRANSFORMER, RF: tuned; 13.355 to 24.755 Mc; .76 microhenries, ± 0.08 microhenries, $Q=225$; tapped at .50 microhenries, ± 0.05 microhenries.	Osc. Coil, Band 5	A-1356
L18	TRANSFORMER, RF: tuned; 21.255 to 35.455 Mc; .25 microhenries, ± 0.03 microhenries, $Q=145$; tapped at 1-1/4 turns.	Osc. Coil, Band 6	A-1355
L19	TRANSFORMER, RF: tuned; 7.2 microhenries, $\pm 5\%$, $Q=110$.	2nd Converter & Oscillator	A-1041
L20	COIL, RF: tuned; 250 microhenries, ± 10 microhenries, $Q=80$.	Crystal Filter Load, S2B	A-944
L21	COIL, peaking: fixed: 700 millihenries, $\pm 5\%$, $Q=55$, $\pm 10\%$.	Filter Audio Spread, S5	CL-117
L22	TRANSFORMER, RF: tuned; 75 microhenries, ± 4 microhenries, $Q=80$; tapped at 33 microhenries, ± 1.5 microhenries.	BFO	A-1043

SYM.	DESCRIPTION	FUNCTION & LOCATION	TMC PART NO.
L23	REACTOR, filter: 11.4 henries, 125 ma. max. current; DC res. approx. 250 ohms; insulated for 2500 volts RMS.	High Voltage Filter	TF-158
L24	Not Used.		
L25	COIL, RF: 200 microhenries; wound on resistor, RC30GF822K.	RF Choke, V4	CL-108-6
L26	COIL, RF: fixed; 128 microhenries, $\pm 10\%$, Q=100.	B+ Choke, S1A	A-1045
L27	COIL, RF: fixed; 128 microhenries, $\pm 10\%$, Q=100.	B+ Choke, S1A	A-1045
L28	COIL, RF: fixed; 26.4 microhenries, $\pm 5\%$, Q=110.	Intermod. Filter, V1	A-1076
L29	COIL, RF: fixed; 13.2 microhenries, $\pm 5\%$, Q=110.	Intermod. Filter, V1	A-1077
L30	COIL, RF: fixed; 26.4 microhenries, $\pm 5\%$, Q=110.	Intermod. Filter, V1	A-1076
L31	COIL, RF: fixed; 128 microhenries, $\pm 10\%$, Q=100.	RF Choke, V12	A-1045
L32	COIL, RF: fixed; 5.57 microhenries, $\pm .25$ microhenries, Q=120.	P/O Low Pass Filter	A-1345
L33	COIL, RF: fixed; 5.57 microhenries, $\pm .25$ microhenries, Q=120.	P/O Low Pass Filter	A-1345
L34	COIL, RF: fixed; 5.57 microhenries, $\pm .25$ microhenries, Q=120.	P/O Low Pass Filter	A-1345
L35	COIL, RF: fixed; 3.03 microhenries, $\pm .15$ microhenries, Q=110.	P/O Low Pass Filter	A-1344
M1	METER, "S" type: white and red illuminated dial.	"S" Meter	MR-107
P1	CONNECTOR, plug: electrical male; two prong; polarized; one 5/32 in. dia. pin, one 1/8 in. dia. pin.	Relay Plug	PL-123
	SHIELD, electrical connector: 5/8 in. o.d. x 11/16 in. lg.; with liner.	P/O P1	PL-124
PL1	CONNECTOR, plug: electrical; eight pin, octal; polarized; with associated wiring.	AC Operation Plug	A-1021
R1	RESISTOR, fixed: composition; 220 ohms, $\pm 10\%$; 1/2 watt.	Cathode Bias Res., V1	RC20GF221K

SYM.	DESCRIPTION	FUNCTION & LOCATION	TMC PART NO.
R2	RESISTOR, fixed: composition; 100,000 ohms, $\pm 10\%$; 1/2 watt.	AVC Bias V1	RC20GF104K
R3	RESISTOR, fixed: composition; 4700 ohms, $\pm 5\%$; 1/2 watt.	Plate Load L4	RC20GF472J
R4	RESISTOR, fixed composition; 22,000 ohms, $\pm 5\%$; 1 watt.	Plate Load L5	RC30GF223J
R5	RESISTOR, fixed: composition; 15,000 ohms, $\pm 5\%$; 1 watt.	Plate Load L6	RC30GF153J
R6	RESISTOR, fixed: composition; 4700 ohms, $\pm 10\%$; 1 watt.	B+ Decoupling S1B	RC30GF472K
R7	RESISTOR, fixed: composition; 100,000 ohms, $\pm 10\%$; 1/2 watt.	AVC Bias L6	RC20GF104K
R8	RESISTOR, fixed: composition; 22 ohms, $\pm 10\%$; 1/2 watt.	Parasitic Supp. V2	RC20GF220K
R9	RESISTOR, fixed: composition; 39 ohms, $\pm 10\%$; 1/2 watt.	Degeneration V2	RC20GF390K
R10	RESISTOR, fixed: composition; 220 ohms, $\pm 10\%$; 1/2 watt.	Cathode Bias V2	RC20GF221K
R11	RESISTOR, fixed: composition; 56,000 ohms, $\pm 10\%$; 1/2 watt.	Screen Load V2	RC20GF563K
R12	RESISTOR, fixed: composition; 1000 ohms, $\pm 10\%$; 1/2 watt.	Plate Load L10	RC20GF102K
R13	RESISTOR, fixed: composition; 15,000 ohms, $\pm 5\%$; 2 watt.	Plate Load L11	RC42GF153J
R14	RESISTOR, fixed: composition; 4700 ohms, $\pm 10\%$; 1/2 watt.	B+ Bypass S1D	RC20GF472K
R15	RESISTOR, fixed: composition; 22 ohms, $\pm 10\%$; 1/2 watt.	Parasitic Supp. V3	RC20GF220K
R16	RESISTOR, fixed: composition; 100,000 ohms, $\pm 10\%$; 1/2 watt.	Grid Bias L12	RC20GF104K
R17	RESISTOR, fixed: composition; 100 ohms, $\pm 5\%$; 1/2 watt.	Osc. Injection V3	RC20GF101J
R18	RESISTOR, fixed: composition; 330 ohms, $\pm 10\%$; 1/2 watt.	Degeneration V3	RC20GF331K
R19	RESISTOR, fixed: composition; 2700 ohms, $\pm 10\%$; 1/2 watt.	Cathode Bias V3	RC20GF272K
R20	RESISTOR, fixed: composition; 150,000 ohms, $\pm 10\%$; 1/2 watt.	Screen Load V3	RC20GF154K

SYM.	DESCRIPTION	FUNCTION & LOCATION	TMC PART NO.
R21	RESISTOR, fixed: composition; 4700 ohms, $\pm 10\%$; 1/2 watt.	B+ Decoupling T4	RC20GF472K
R22	RESISTOR, fixed: composition; 10,000 ohms, $\pm 10\%$, 1/2 watt.	Screen Load V4	RC20GF103K
R23	RESISTOR, fixed: composition; 47 ohms, $\pm 10\%$; 1/2 watt.	Parasitic Suppressor V4	RC20GF470K
R24	RESISTOR, fixed: composition; 150 ohms, $\pm 5\%$; 1/2 watt.	Cathode Bias V4	RC20GF151J
R25	RESISTOR, fixed: composition; 15,000 ohms, $\pm 5\%$; 1/2 watt.	Grid Leak V4	RC20GF153J
R26	RESISTOR, fixed: composition; 47 ohms, $\pm 10\%$; 1/2 watt.	Parasitic Suppressor V4	RC20GF470K
R27	RESISTOR, fixed: composition; 510 ohms, $\pm 5\%$; 1/2 watt.	Cathode Bias V5	RC20GF511J
R28	RESISTOR, fixed: composition; 100,000 ohms, $\pm 10\%$; 1/2 watt.	Screen Load V5	RC20GF104K
R29	RESISTOR, fixed: composition; 12,000 ohms, $\pm 10\%$; 1/2 watt.	B+ Decoupling S1A	RC20GF123K
R30	RESISTOR, fixed: composition; 390,000 ohms, $\pm 10\%$; 1/2 watt.	Shunting P/O T5	RC20GF394K
R31	RESISTOR, fixed: composition; 6800 ohms, $\pm 10\%$; 1/2 watt.	B+ Decoupling T5	RC20GF682K
R32	RESISTOR, fixed: composition; 10 ohms, $\pm 5\%$; 1/2 watt.	Crystal Filter	RC20GF100J
R33	RESISTOR, fixed: composition; 10 ohms, $\pm 5\%$; 1/2 watt.	Crystal Filter	RC20GF100J
R34	RESISTOR, fixed: composition; 22 ohms, $\pm 5\%$; 1/2 watt.	Crystal Filter	RC20GF220J
R35	RESISTOR, fixed: composition; 100 ohms, $\pm 5\%$; 1/2 watt.	Crystal Filter	RC20GF101J
R36	RESISTOR, fixed: composition; 22 ohms, $\pm 10\%$; 1/2 watt.	Parasitic Supp. V6	RC20GF220K
R37	RESISTOR, fixed: composition; 1 megohm, $\pm 10\%$; 1/2 watt.	Isolation V6	RC20GF105K
R38	RESISTOR, fixed: composition; 100,000 ohms, $\pm 10\%$; 1/2 watt.	AVC Bias L20	RC20GF104K
R39	RESISTOR, fixed: composition; 220 ohms, $\pm 5\%$; 1/2 watt.	Cathode Bias V6	RC20GF221K
R40	RESISTOR, fixed: composition; 56,000 ohms, $\pm 10\%$; 1 watt.	Screen Load V6	RC30GF563K

SYM.	DESCRIPTION	FUNCTION & LOCATION	TMC PART NO.
R41	RESISTOR, fixed: composition; 56,000 ohms, $\pm 10\%$; 1/2 watt.	Shunt P/O T6	RC20GF563K
R42	RESISTOR, fixed: composition; 6800 ohms, $\pm 10\%$; 1 watt.	B+ Decoupling T6	RC30GF682K
R43	RESISTOR, fixed: composition; 100,000 ohms, $\pm 10\%$; 1/2 watt.	AVC Bias T6	RC20GF104K
R44	RESISTOR, fixed: composition; 22 ohms, $\pm 10\%$; 1/2 watt.	Parasitic Suppressor V7	RC20GF220K
R45	RESISTOR, fixed: composition; 220 ohms, $\pm 10\%$; 1/2 watt.	Cathode Bias V7	RC20GF221K
R46	RESISTOR, fixed: composition; 12,000 ohms, $\pm 10\%$; 1/2 watt.	"S" Meter Bridge	RC20GF123K
R47	RESISTOR, fixed: composition; 56,000 ohms, $\pm 10\%$; 1 watt.	Screen Load V7	RC30GF563K
R48	RESISTOR, fixed: composition; 56,000 ohms, $\pm 10\%$; 1/2 watt.	Shunt P/O T7	RC20GF563K
R49	RESISTOR, fixed: composition; 33,000 ohms, $\pm 5\%$; 2 watts.	"S" Meter Bridge	RC42GF333J
R50	RESISTOR, variable: composition; 22,000 ohms, $\pm 20\%$; linear, 2 watts.	"S" Meter Adj.	RV4ATSA103B
R51	RESISTOR, fixed: composition; 22,000 ohms, $\pm 5\%$; 2 watts.	"S" Meter Bridge	RC42GF223J
R52	RESISTOR, fixed: composition; 6800 ohms, $\pm 10\%$; 2 watts.	B+ Decoupler T7	RC42GF682K
R53	RESISTOR, fixed: composition; 22 ohms, $\pm 10\%$; 1/2 watt.	Parasitic Supp. V8	RC20GF220K
R54	RESISTOR, fixed: composition; 220 ohms, $\pm 10\%$; 1/2 watt.	Cathode Bias V8	RC20GF221K
R55	RESISTOR, fixed: composition; 56,000 ohms, $\pm 10\%$; 1 watt.	Screen Load V8	RC30GF563K
R56	RESISTOR, fixed: composition; 56,000 ohms, $\pm 10\%$; 1/2 watt.	Shunt P/O T8	RC20GF563K
R57	RESISTOR, fixed: composition; 6800 ohms, $\pm 10\%$; 1 watt.	B+ Decoupler T8	RC30GF682K
R58	RESISTOR, fixed: composition; 47,000 ohms, $\pm 10\%$; 1/2 watt.	Detector Load V9	RC20GF473K
R59	RESISTOR, fixed: composition; 1 megohm, $\pm 10\%$; 1/2 watt.	Noise Limiter V9	RC20GF105K

SYM.	DESCRIPTION	FUNCTION & LOCATION	TMC PART NO.
R60	RESISTOR, fixed: composition; 220,000 ohms, $\pm 10\%$; 1/2 watt.	Detector Load V9	RC20GF224K
R61	RESISTOR, fixed: composition; 470,000 ohms, $\pm 10\%$; 1/2 watt.	Detector Load V9	RC20GF474K
R62	RESISTOR, fixed: composition; 820,000 ohms, $\pm 10\%$; 1/2 watt.	Noise Limiter V9	RC20GF824K
R63	RESISTOR, fixed: composition; 12 megohms, $\pm 10\%$; 1/2 watt.	AVC V10	RC20GF125K
R64	RESISTOR, fixed: composition; 12 megohms, $\pm 10\%$; 1/2 watt.	AVC V10	RC20GF125K
R65	RESISTOR, fixed: composition; 4700 ohms, $\pm 10\%$; 1/2 watt.	Volt. Divider V10	RC20GF472K
R66	RESISTOR, fixed: composition; 330,000 ohms, $\pm 10\%$; 1/2 watt.	Volt. Divider V10	RC20GF334K
R67	RESISTOR, fixed: composition; 8.2 megohms; $\pm 10\%$; 1/2 watt.	Grid Leak V10	RC20GF825K
R68	RESISTOR, variable: composition; 1 megohm, $\pm 20\%$; log; 2 watts.	Audio Gain	RV4ATRD105D
R69	RESISTOR, fixed: composition; 220 ohms, $\pm 10\%$; 1/2 watt.	Feed Back V10	RC20GF221K
R70	RESISTOR, fixed: composition; 120,000 ohms, $\pm 10\%$; 1/2 watt.	Feed Back V10	RC20GF124K
R71	RESISTOR, variable: composition; 1500 ohms, $\pm 20\%$; linear, 2 watts.	Audio Spread	RV4ATRC125B
R72	RESISTOR, fixed: composition; 22,000 ohms, $\pm 10\%$; 1 watt.	Plate Load S5	RC30GF223K
R73	RESISTOR, fixed: composition; 470,000 ohms, $\pm 10\%$; 1/2 watt.	Grid Leak V11	RC20GF474K
R74	RESISTOR, fixed: composition; 300 ohms, $\pm 5\%$; 2 watts.	Cathode Bias V11	RC42GF301J
R75	RESISTOR, fixed: composition; 560 ohms, $\pm 10\%$; 2 watts.	Phone Shunt J2	RC42GF561K
R76	RESISTOR, fixed: composition; 56,000 ohms, $\pm 10\%$; 1/2 watt.	B+ Decoupler V14	RC20GF563K
R77	RESISTOR, fixed: 680,000 ohms, $\pm 10\%$; 1/2 watt.	Plate Load Res. V16	RC20GF684K
R78	RESISTOR, fixed: composition; 22,000 ohms, $\pm 10\%$; 1/2 watt.	Grid Lead Res. V12	RC20GF223K
R79	RESISTOR, fixed: composition; 2700 ohms, $\pm 10\%$; 1/2 watt.	Plate Decoupler Res. V12	RC20GF272K

SYM.	DESCRIPTION	FUNCTION & LOCATION	TMC PART NO.
R80	RESISTOR, fixed: composition; 22,000 ohms, $\pm 10\%$; 1/2 watt.	Screen Load V12	RC20GF223K
R81	RESISTOR, variable: composition; 5000 ohms, $\pm 10\%$; linear, 2 watts, with switch.	RF Gain Power ON/OFF	RV4BTRD502E
R82	RESISTOR, fixed: composition; 47,000 ohms, $\pm 10\%$; 1/2 watt.	Grid Leak P/O L22	RC20GF473K
R83	RESISTOR, fixed: composition; 22 ohms, $\pm 10\%$; 1/2 watt.	Parasitic Supp. V13	RC20GF220K
R84	RESISTOR, fixed: composition; 120,000 ohms, $\pm 10\%$; 1/2 watt.	Screen Load V13	RC20GF124K
R85	RESISTOR, fixed: composition; 120,000 ohms, $\pm 10\%$; 1/2 watt.	Voltage Divider V13	RC20GF124K
R86	RESISTOR, fixed: composition; 220,000 ohms, $\pm 10\%$; 1/2 watt.	Voltage Divider V13	RC20GF224K
R87	RESISTOR, fixed: W.W.; 5000 ohms, 20 watts.	B+ Dropping V14	RW-110-30
R88	RESISTOR, fixed: composition; 4.7 ohms, $\pm 5\%$; 1 watt.	Filter Voltage Dropping V9	RC30GF4R7J
R89	RESISTOR, fixed: composition; 10 ohms, $\pm 10\%$; 1/2 watt.	Parasitic Supp. L7	RC20GF100K
R90	RESISTOR, fixed: composition; 10 ohms, $\pm 10\%$; 1/2 watt.	Parasitic Supp. L8	RC20GF100K
R91	RESISTOR, fixed: composition; 10 ohms, $\pm 10\%$; 1/2 watt.	Parasitic Supp. V1	RC20GF100K
R92	RESISTOR, fixed: composition; 15,000 ohms, $\pm 5\%$; 2 watts.	Plate Load L12	RC42GF153J
R93	RESISTOR, fixed: composition; 1000 ohms, $\pm 5\%$; 1/2 watt.	Plate Decoupler V12	RC20GF102J
R94	RESISTOR, variable: W.W.; 250 ohms, $\pm 10\%$; linear taper. 2 watt.	Hum Bal. Res.	RA101ASSA251A
R95	RESISTOR, fixed: composition; 270,000 ohms, $\pm 10\%$; 1/2 watt.	Screen Res. V16	RC20GF274K
R96	RESISTOR, fixed: composition; 6800 ohms, $\pm 10\%$; 1/2 watt.	Cathode Bias Res. V16	RC20GF682K
R97	RESISTOR, fixed: composition; 470,000 ohms, $\pm 10\%$; 1/2 watt.	Grid Res. V16	RC20GF474K
S1	SWITCH, rotary: index; 6 position 1/4 in. dia. flatted shaft.	Band Switch	SW-162

SYM.	DESCRIPTION	FUNCTION & LOCATION	TMC PART NO.
S1A	WAFER, switch: shorting; rotary type; front section, 4 contacts; (1 common); rear section, 3 contacts (1 common); bakelite insulation; terminals brass, silver plated.	Band Switch	WS-100-1
S1AA	WAFER, switch: shorting; rotary type; front section; three contacts, (one common); rear section, seven contacts, (one common); bakelite insulation; terminals brass, silver plated.	Band Switch	WS-100-7
S1B	WAFER, switch: shorting; rotary type; front section, 7 contacts (1 common); rear section, 7 contacts (1 common); bakelite insulation; terminals brass, silver plated.	Band Switch	WS-100-6
S1C	WAFER, switch: shorting; rotary type; front section, 8 contacts (1 common); rear section, 8 contacts; bakelite insulation; terminals brass, silver plated.	Band Switch	WS-100-3
S1D	WAFER, switch: shorting; rotary type; front section, 7 contacts (1 common); rear section, 7 contacts (1 common); bakelite insulation; terminals brass, silver plated.	Band Switch	WS-100-2
S1E	Wafer, switch: shorting; rotary type; front section, 8 contacts (1 common); rear section; 8 contacts; bakelite insulation; terminals brass, silver plated.	Band Switch	WS-100-3
S1F	WAFER, switch: shorting; rotary type; front section, 7 contacts (1 common); rear section, 7 contacts (1 common); ceramic insulation; terminals brass, silver plated.	Band Switch	WS-100-4
S1G	WAFER, switch: shorting; rotary type; front section, 8 contacts (1 common); rear section, 8 contacts; ceramic insulation; terminals brass, silver plated.	Band Switch	WS-100-5
S2 A,B	SWITCH, rotary: non-shorting; one section; single pole; six positions; bakelite insulation; terminals brass, silver plated; 1/4 in. dia. shaft, 2-7/8 in. long.	Crystal Filter Switch Y1	SW-147

SYM.	DESCRIPTION	FUNCTION & LOCATION	TMC PART NO.
S3	SWITCH, toggle: SPST; 3 A at 250 v, 6 A at 125 v.	AVC ON/OFF	ST-103-1-62
S4	SWITCH, toggle: SPST; 3 A at 250 v, 6 A at 125 v.	Noise Limiter	ST-103-1-62
S5	SWITCH, rotary: 2 sections; 3 positions.	Audio Selectivity	SW-156
S6 A,B	SWITCH, sliding: DPDT; 125 v, at .5 A.	Radio-Phono	SW-163
S7 A,B	SWITCH, sliding: SPST; 125 v, at .5 A.	SSB ON/OFF	SW-163
S8	SWITCH, toggle: SPST; 3 A at 250 v, 6 A at 125 v.	BFO ON/OFF	ST-103-1-62
S9	SWITCH, toggle: SPST; 3 A at 250 v, 6 A at 125 v.	BFO ON/OFF	ST-103-1-62
S10	SWITCH, part of R81.	Send-Receiver Power ON/OFF	P/O R81
S11	SWITCH, toggle: SPST; 3 A at 250 v., 6 A at 125 v.; bat type toggle.	Xtal Calib. ON/OFF	ST-103-1-62
T1	TRANSFORMER, Antenna matching; 70 ohms unbalanced to 300 ohms balanced; 2-30 MC ± 3 db.	Ant. Input	TR-116
T2	TRANSFORMER, Input: assembly.	2nd Converter Input	A-1040
T3	TRANSFORMER, RF: sec. #1-95 microhenries, Q=82, #2-6.2 microhenries, Q=110.	Composite IF	A-1038
T4	TRANSFORMER, RF: sec. #1-95 microhenries, Q=82, #2-6.2 microhenries, Q=110.	Composite IF	P/O T3
T5	TRANSFORMER, Assembly: tuned; pri 415 microhenries, Q=90; Sec. 40 microhenries, Q=65.	Crystal Filter Input	A-1034
T6	TRANSFORMER, Assembly; tuned; 95 microhenries, Q=82, each pi.	1st 455 Kc IF	A-1039
T7	TRANSFORMER, Assembly: tuned; 95 microhenries, Q=82, each pi.	2nd 455 Kc IF	A-1039
T8	TRANSFORMER, Assembly: tuned; 95 microhenries, Q=82, each pi.	3rd 455 Kc IF	A-1039

SYM.	DESCRIPTION	FUNCTION & LOCATION	TMC PART NO.
T9	TRANSFORMER, Output: audio; 100-10,000 cps, ± 3 db, pri 5000 ohms, 55 ma DC; Sec. 600, 18,6,4 ohms, 5 w. max.	Output	TF-159
T10	TRANSFORMER, power: primary, 115/230 volts, 50/60 cps; secondary #1, 5 volts at 3 amps; secondary #2, 275-0-275 volts at 110 ma.; secondary #3, 6.3 volts at 5.65 amps; insulated for 1000 volts.	Power	TF-169
T11	AUTOTRANSFORMER; 128 microhenries, $\pm 10\%$; Q=100.	2nd Converter Output	A-989
V1	TUBE, electron: RF triode; 7 pin miniature.	1st RF Ampl.	6AB4
V2	TUBE, electron: sharp cutoff RF pentode; 7 pin miniature.	2nd RF Ampl.	6CB6
V3	TUBE, electron: sharp cutoff RF pentode; 7 pin miniature.	1st Converter	6AU6
V4	TUBE, electron: heptode converter; 7 pin miniature.	2nd Converter and Oscillator	6BE6
V5	TUBE, electron: remote cutoff RF pentode; 7 pin miniature.	Buffer IF	6BA6
V6	TUBE, electron: remote cutoff RF pentode; 7 pin miniature.	1st IF Ampl.	6BA6
V7	TUBE, electron: remote cutoff RF pentode; 7 pin miniature.	2nd IF Ampl.	6BA6
V8	TUBE, electron: remote cutoff RF pentode; 7 pin miniature.	3rd IF Ampl.	6BA6
V9	TUBE, electron: duo-diode; 7 pin miniature.	Detector and Noise Limiter	6AL5
V10	TUBE, electron: 12AX7; 9 pin min.	AVC & 1st Audio	12AX7
V11	TUBE, electron: 6V6; octal.	2nd Audio	6V6
V12	TUBE, electron: 6AG5; 7 pin min.	Osc.	6AG5
V13	TUBE, electron: 6AG5; 7 pin min.	BFO	6AG5
V14	TUBE, electron; 5U4G; octal.	Rectifier	5U4G
V15	TUBE, electron: OA2; 7 pin min.	Voltage Regulator	OA2
V16	TUBE, electron: sharp cutoff RF pentode; 7 pin miniature.	100 Kc Osc.	6CB6

SYM.	DESCRIPTION	FUNCTION & LOCATION	TMC PART NO.
W1	CABLE ASSEMBLY: power; consists of one moulded non-polarized male plug, two contacts and six feet of 18/2 SJ rubber covered cable; opposite end stripped.	Line Cord	CA-102-2
X1	SOCKET, electron tube: octal; ceramic.	Power Socket	TS101P01
X2	SOCKET, electron tube: octal; ceramic.	Accessory Socket	TS101P01
XF1	HOLDER, fuse: extractor post type for single AGC type fuse; stationary end terminal.	F1 Socket	FH-100-2
XI1	SOCKET, bracket: for miniature bayonet base T-3-1/4 bulb; right angle, down turned.	I1 Socket	TS-107-2
XI2	SOCKET, bracket: for miniature bayonet base T-3-1/4 bulb; right angle, down turned.	I2 Socket	TS-107-2
XI3	SOCKET, lamp: for miniature bayonet base T-3-1/4 bulb; 10 in. leads; for insertion into rear of meter.	I3 Socket	TS-127
XV1	SOCKET, electron tube: 7 pin miniature.	V1 Socket	TS102P01
XV2	SOCKET, electron tube: 7 pin miniature.	V2 Socket	TS102P01
XV3	SOCKET, electron tube: 7 pin miniature.	V3 Socket	TS102P01
XV4	SOCKET, electron tube: 7 pin miniature.	V4 Socket	TS102P01
XV5	SOCKET, electron tube: 7 pin miniature.	V5 Socket	TS102P01
XV6	SOCKET, electron tube: 7 pin miniature.	V6 Socket	TS102P01
XV7	SOCKET, electron tube: 7 pin miniature.	V7 Socket	TS102P01
XV8	SOCKET, electron tube: 7 pin miniature.	V8 Socket	TS102P01
XV9	SOCKET, electron tube: 7 pin miniature.	V9 Socket	TS102P01
XV10	SOCKET, electron tube: 9 pin miniature.	V10 Socket	TS103P01

SYM.	DESCRIPTION	FUNCTION & LOCATION	TMC PART NO.
XV11	SOCKET, electron tube: octal; ceramic.	V11 Socket	TS101P01
XV12	SOCKET, electron tube: ceramic; 7 pin miniature.	V12 Socket	TS102C01
XV13	SOCKET, electron tube: 7 pin miniature.	V13 Socket	TS102P01
XV14	SOCKET, electron tube: octal; ceramic.	V14 Socket	TS101P01
XV15	SOCKET, electron tube: 7 pin miniature.	V15 Socket	TS102P01
XV16	SOCKET, electron tube: 7 pin miniature.	V16 Socket	TS102P01
XY3	SOCKET, crystal: .487 in. spacing for .095 in. dia. pins.	Y3 Socket	TS-105-1
Y1	CRYSTAL UNIT: quartz; 455 Kcs, ±.02%; 2 in. solder leads.	Xtal Filter	CR-102
Y2	CRYSTAL UNIT: quartz; 3.5 Mcs, ±.02%; 2 in. solder leads.	Oscillator, V4	CR-103
Y3	CRYSTAL UNIT: quartz; 100 Kcs, ±.005%.	100 Kc Osc., V16	CR-100

NOTES

NOTES

SALES SERVICE INFORMATION

The Technical Materiel Corporation
Mamaroneck New York

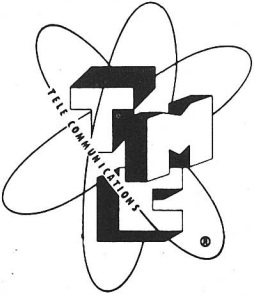

LET'S TALK CALIBRATION!

or

TO QUOTE A FAMOUS SLOGAN - "YOU CAN TEACH A PARROT TO SAY
'JUST AS GOOD' BUT HE WON'T KNOW
WHAT HE'S TALKING ABOUT".

1. The GPR-90 is a general coverage receiver, and a real good one, but it is NOT a frequency meter.
2. People who require frequency meters should buy frequency meters - not make them double as communications receivers.
3. Let's lock the GPR-90 bandspread dial at 100 and forget it for the time being. The main tuning dial now covers the following range in frequency:

Band 1	-	.54	to	1.4	Mcs	-	10	Kcs	per	division
Band 2	-	1.4	to	3.3	Mcs	-	20	Kcs	per	division
Band 3	-	3.2	to	5.6	Mcs	-	25	Kcs	per	division
Band 4	-	5.4	to	9.7	Mcs	-	50	Kcs	per	division
Band 5	-	9.5	to	17.8	Mcs	-	100	Kcs	per	division
Band 6	-	17.3	to	31.5	Mcs	-	100	Kcs	per	division

Please note that in order to change frequency 10 Kcs on Band 1, you move the dial marking about 1/32nd of an inch - and to move 100 Kcs on Band 6, you move the dial marking about 1/16th of an inch. Movement at the hub is infinitesimal.

NOW COMES THE DIFFICULTY:

Remember that the GPR-90 is a general coverage receiver. It must maintain its sensitivity and selectivity, i. e., tracking, over almost 1 Mc on Band 1 and 14 Mcs on Band 6. If the GPR-90 was an Amateur Band Receiver only, it would be required to track only from 28 to 29.7 Mcs at its highest frequency, a total of 1.7 Mcs and on "Twenty Meters" only from 14.000 to 14.350 Mcs - an excursion of only 350 Kcs. Obviously, the latter is a darn sight easier to do. WHY? - Because coils and condensers can only be made to certain tolerances. These tolerances do not bother you over a small range but can really hurt over a wide excursion. Notice that on "Twenty", movement of the dial marker 1/16 inch changes your frequency 100 Kcs on one-quarter of the Amateur band.

NOW COMES ANOTHER PROBLEM:

PARALLAX. The GPR-90 dial has a very fine fiduciary - (high class word for indicator line). This line is placed as close to the dial as possible without rubbing. As long as you look at the line "Straight On", everything is okay - but look at it from left or right and you get a different reading - hence PARALLAX.

The coils in the GPR-90 are made to the most exacting standards, and the condensers are calibrated every 10% of rotation. Accuracy of each point is $\pm (1 \text{ mmf} + 1. \%)$ of tabulated value. At these prices you "can't hardly get 'em any better". Minute variations of these components in a general coverage receiver over a large excursion can result in a one-half dial division error, 1/32 inch to 1/64 inch in marking movement.

SO LET'S GO BACK TO THE BANDSPREAD DIAL:

We provide real fine hairlines on the main tuning dial and we have just said they can be off 1/32 to 1/64 inch, add PARALLAX, and your bandspread can very possibly be off when you set the main dial exactly at the hairline. Now, because your bandspread dial does what it's supposed to do, i.e., spread the band, the error is much more noticeable.

SO HOW DO I SET MY BANDSPREAD?

Well - if you lock your bandspread at 100 and set the main tuning dial at the hairline, you will be pretty close; but if you want frequency-meter accuracy, you had better use a crystal calibrator - calibrated against WWV - or any crystal that has an identifiable signal in the band you are working. Set your bandspread dial first to the crystal frequency and then rotate the main tuning dial until the signal is audible. Then your GPR-90 becomes a frequency-meter over any reasonable excursion of the bandspread dial - BUT LOOK OUT - make sure the 100 Kc calibrator is zero beat with WWV or make sure that the crystal you use has the accuracy you expect, because even crystals have tolerances. .005% is darn good, so is .01% for amateur work and .01% at 30 Mcs is 3 Kcs.

Now - having read this opus - we want to tell you that the oscillator in any of the six bands in the GPR-90 may be adjusted at any point in these bands to exceptional accuracy without removing the receiver from the cabinet. The air trimmers can be reached through the six holes underneath the cabinet with an insulated screwdriver - BUT DON'T TURN 'EM FAR - in fact, hardly breathe on them because that's what you're talking about.

Any receiver can go off a hairbreadth in shipment. We're no exception - and we don't provide moveable fiduciaries either! But be careful - because the GPR-90 is calibrated as well or better than any other general coverage receiver on the market.

BAND TUNING RANGE	
1	.54 - 1.4 mc
2	1.4 - 3.3
3	3.2 - 5.6 mc
4	5.4 - 9.7 mc
5	9.4 - 17.8 mc
6	17.3 - 31.5 mc

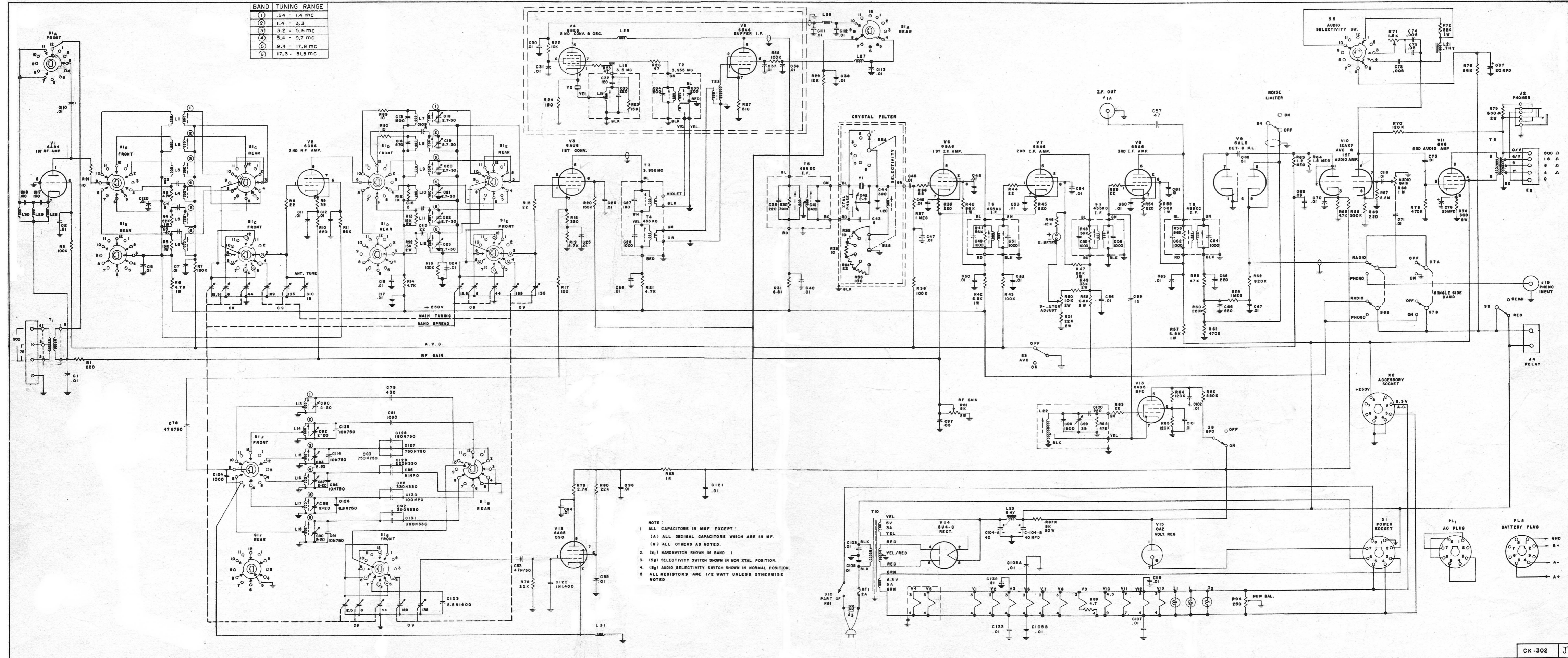

BAND	TUNING RANGE
(1)	.54 - 1.4 mc
(2)	1.4 - 3.3
(3)	3.2 - 5.6 mc
(4)	5.4 - 9.7 mc
(5)	9.4 - 17.8 mc
(6)	17.3 - 31.5 mc

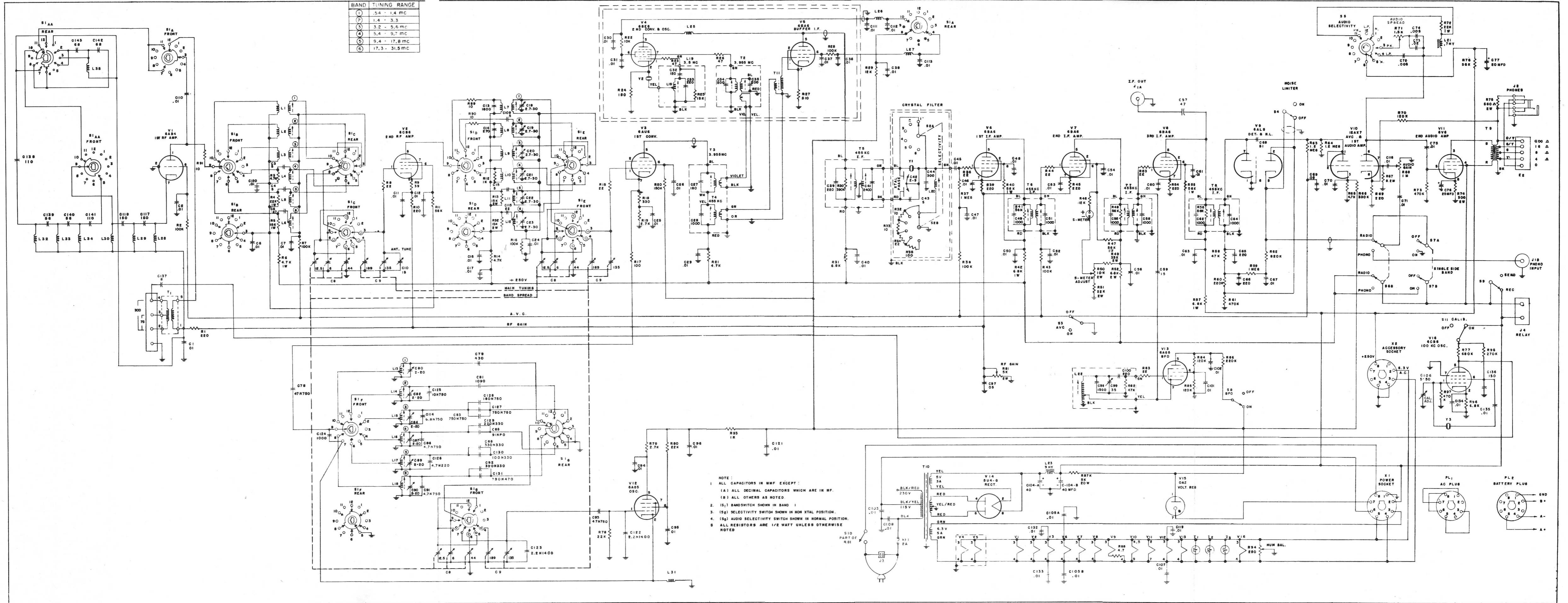

NOTE:
 1. ALL CAPACITORS IN MMF EXCEPT:
 (A) ALL DECIMAL CAPACITORS WHICH ARE IN MF.
 (B) ALL OTHERS AS NOTED.
 2. (S1) BANDSWITCH SHOWN IN BAND 1.
 3. (S2) SELECTIVITY SWITCH SHOWN IN NON XTAL POSITION.
 4. (S3) AUDIO SELECTIVITY SWITCH SHOWN IN NORMAL POSITION.
 5. ALL RESISTORS ARE 1/2 WATT UNLESS OTHERWISE NOTED.

