

NOTICE

THE CONTENTS AND INFORMATION CONTAINED IN THIS INSTRUCTION MANUAL IS PROPRIETARY TO THE TECHNICAL MATERIEL CORPORATION TO BE USED AS A GUIDE TO THE OPERATION AND MAINTENANCE OF THE EQUIPMENT FOR WHICH THE MANUAL IS ISSUED AND MAY NOT BE DUPLICATED EITHER IN WHOLE OR IN PART BY ANY MEANS WHATSOEVER WITHOUT THE WRITTEN CONSENT OF THE TECHNICAL MATERIEL CORPORATION.

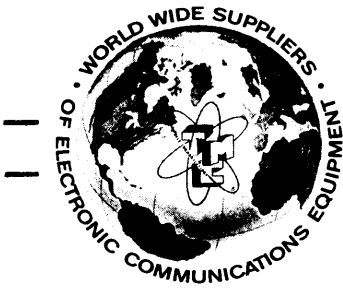

THE TECHNICAL MATERIEL CORPORATION

C O M M U N I C A T I O N S E N G I N E E R S

700 FENIMORE ROAD

MAMARONECK, N. Y.

W a r r a n t y

The Technical Materiel Corporation, hereinafter referred to as TMC, warrants the equipment (except electron tubes,*fuses, lamps, batteries and articles made of glass or other fragile or other expendable materials) purchased hereunder to be free from defect in materials and workmanship under normal use and service, when used for the purposes for which the same is designed, for a period of one year from the date of delivery F.O.B. factory. TMC further warrants that the equipment will perform in a manner equal to or better than published technical specifications as amended by any additions or corrections thereto accompanying the formal equipment offer.

TMC will replace or repair any such defective items, F.O.B. factory, which may fail within the stated warranty period, PROVIDED:

1. That any claim of defect under this warranty is made within sixty (60) days after discovery thereof and that inspection by TMC, if required, indicates the validity of such claim to TMC's satisfaction.
2. That the defect is not the result of damage incurred in shipment from or to the factory.
3. That the equipment has not been altered in any way either as to design or use whether by replacement parts not supplied or approved by TMC, or otherwise.
4. That any equipment or accessories furnished but not manufactured by TMC, or not of TMC design shall be subject only to such adjustments as TMC may obtain from the supplier thereof.

Electron tubes*furnished by TMC, but manufactured by others, bear only the warranty given by such other manufacturers. Electron tube warranty claims should be made directly to the manufacturer of such tubes.

TMC's obligation under this warranty is limited to the repair or replacement of defective parts with the exceptions noted above.

At TMC's option any defective part or equipment which fails within the warranty period shall be returned to TMC's factory for inspection, properly packed with shipping charges prepaid. No parts or equipment shall be returned to TMC, unless a return authorization is issued by TMC.

No warranties, express or implied, other than those specifically set forth herein shall be applicable to any equipment manufactured or furnished by TMC and the foregoing warranty shall constitute the Buyers sole right and remedy. In no event does TMC assume any liability for consequential damages, or for loss, damage or expense directly or indirectly arising from the use of TMC Products, or any inability to use them either separately or in combination with other equipment or materials or from any other cause.

*Electron tubes also include semi-conductor devices.

PROCEDURE FOR RETURN OF MATERIAL OR EQUIPMENT

Should it be necessary to return equipment or material for repair or replacement, whether within warranty or otherwise, a return authorization must be obtained from TMC prior to shipment. The request for return authorization should include the following information:

1. Model Number of Equipment.
2. Serial Number of Equipment.
3. TMC Part Number.
4. Nature of defect or cause of failure.
5. The contract or purchase order under which equipment was delivered.

PROCEDURE FOR ORDERING REPLACEMENT PARTS

When ordering replacement parts, the following information must be included in the order as applicable:

1. Quantity Required.
2. TMC Part Number.
3. Equipment in which used by TMC or Military Model Number.
4. Brief Description of the Item.
5. The *Crystal Frequency* if the order includes crystals.

PROCEDURE IN THE EVENT OF DAMAGE INCURRED IN SHIPMENT

TMC's Warranty specifically excludes damage incurred in shipment to or from the factory. In the event equipment is received in damaged condition, the carrier should be notified immediately. Claims for such damage should be filed with the carrier involved and not with TMC.

All correspondence pertaining to Warranty Claims, return, repair, or replacement and all material or equipment returned for repair or replacement, within Warranty or otherwise, should be addressed as follows:

THE TECHNICAL MATERIEL CORPORATION
Engineering Services Department
700 Fenimore Road
Mamaroneck, New York

TABLE OF CONTENTS

Paragraph	Page
SECTION 1—GENERAL INFORMATION	
1-1 Functional Description	1-1
1-2 Physical Description	1-1
SECTION 2—INSTALLATION	
2-1 Unpacking and Handling	2-1
2-2 Power Requirement	2-1
2-3 Installation Layout	2-1
2-4 Installation Requirements	2-2
2-5 Performance Checks	2-2
SECTION 3—OPERATOR'S SECTION	
3-1 Controls and Indicators	3-1
3-2 General Operating Notes	3-4
3-3 Tuning Procedures	3-6
3-4 Operator's Checks	3-7
SECTION 4—PRINCIPLES OF OPERATION	
4-1 General	4-1
4-2 Block Diagram Theory	4-1
4-3 Circuit Analysis	4-2
SECTION 5—MAINTENANCE	
5-1 Preventive Maintenance	5-1
5-2 Corrective Maintenance	5-1
SECTION 6—PARTS LIST	
SECTION 7—SCHEMATIC DIAGRAM	

LIST OF ILLUSTRATIONS

Figure	Page
SECTION 1—GENERAL INFORMATION	
1-1 General Purpose Receiver GPR-92A	iv
SECTION 2—INSTALLATION	
2-1 Power Transformer Wiring	2-1
2-2 GPR-92A, Rear View	2-2
SECTION 3—OPERATOR'S SECTION	
3-1 Controls and Indicators	3-1
SECTION 4—PRINCIPLES OF OPERATION	
4-1 General Purpose Receiver GPR-92A, Block Diagram	4-3
4-2 I-F Filter FL102	4-6
SECTION 5—MAINTENANCE	
5-1 GPR-92A, Top View with Cover Removed	5-5
5-2 GPR-92A, Bottom View with Cover Removed	5-6
5-3 RF Gear Train Assembly, Exploded View	5-9
5-4 Impedance-matching Attenuator Pad . .	5-11
5-5 I-F Sweep Alignment Test Setup	5-12
SECTION 7—SCHEMATIC DIAGRAM	
7-1 General Purpose Receiver GPR-92A, Schematic Diagram (3 sheets)	7-1

LIST OF TABLES

Table	Page
SECTION 1—GENERAL INFORMATION	
1-1 Reference Data	1-2
1-2 Equipment Supplied	1-3
1-3 Electron Tube and Diode Complement . .	1-4
SECTION 3—OPERATOR'S SECTION	
3-1 Operator Controls and Indicators . . .	3-2
SECTION 5—MAINTENANCE	
5-1 Voltage and Resistance Measurements . .	5-3
5-2 RF Alignment Chart	5-13



3006A-1

Figure 1-1. General Purpose Receiver GPR-92A

SECTION 1

GENERAL INFORMATION

1-1. FUNCTIONAL DESCRIPTION.

The GPR-92A General Purpose Receiver (figure 1-1) is a superheterodyne communications receiver that operates over a frequency range of 0.54 to 32.3 mc. It can be used alone, or as part of a communications system. The GPR-92A can receive the following transmissions:

1. Amplitude modulation (AM).
2. Compatible amplitude modulation (AM equivalent).
3. Continuous wave (CW).
4. Modulated continuous wave (MCW).
5. Single sideband (SSB).
6. Independent sideband (ISB).
7. Frequency shift keying (FSK).
8. Facsimile (FAX).

NOTE

To receive ISB, FSK, and FAX, additional equipment is required.

The frequency range of the receiver is covered in six bands. Electrical bandspreading is provided on all but the broadcast band. An internal crystal-controlled oscillator provides calibration marks at 100 kc intervals throughout the entire tuning range of the receiver for precise tuning. In addition, a dual-scale meter on the front panel indicates either rf signal strength or audio output. The rf reading serves as a tuning indication. The audio output reading allows system level adjustments, which are needed in some systems.

The main features of the GPR-92A include:

1. High sensitivity for good reception under weak signal conditions.
2. Six selectable i-f bandpass values to allow the best selectivity for the type of signal being received.
3. Double i-f frequency conversion on the three highest tuning bands to maintain a high image ratio.
4. Separate rf and audio volume controls and avc circuitry.
5. Rf and audio noise limiting circuits.
6. An adjustable squelch circuit that mutes the audio output and provides an external output to indicate (for alarm purposes) that the receiver is squelched.
7. A REC MUTE input that provides for automatic muting of the receiver when it is coupled to the same antenna as a transmitter.
8. Provision for using external high frequency and bfo oscillators. Each input is supplied

to the receiver circuits through an internal isolation amplifier.

9. IF, AVC, and DIODE LOAD outputs for special system applications. The unit produces three distinct audio outputs. These are speaker outputs for 4, 8, or 16 ohms, an audio output into a 600-ohm balanced load, and an earphone output with a PHONE LEVEL control.

Performance specifications and other reference data for the GPR-92A are given in table 1-1. Table 1-2 lists the equipment supplied with the GPR-92A.

1-2. PHYSICAL DESCRIPTION.

a. EXTERNAL. - The GPR-92A is housed in a sturdy metal case for general use, but can be removed from the case and mounted on a standard 19-inch rack if desired. Two handles are located on the front panel for ease of handling. Dust covers protect the unit when it is rack mounted.

All of the operator's controls are located on the front panel; these are described in table 3-1. A terminal board mounted to the rear panel provides for input and output connections. BNC connectors are provided for the connection of equipment that requires coaxial cabling. In addition, the rear panel contains the power input connector, the line fuse, and the adjustments that are most frequently made. Figure 2-2 illustrates the rear panel components.

b. INTERNAL. - Most of the smaller components are soldered to printed circuit boards, which are mounted to the bottom of the chassis. The components of the rf and local oscillator stages are located in shielded compartments to minimize interference. The tuning and bandspread capacitors, which are located in these compartments, are driven through independent gear trains from the TUNING and BAND SPREAD knobs. Each gear train includes an inertia wheel, spur gears, anti-backlash gears, and a dial lock that prevents accidental detuning. Spur gear ratios have been selected to provide an optimum tuning rate. The inertia wheel simplifies tuning through a large frequency change at this tuning rate. The anti-backlash gears remove play from the gear train that could result in the receiver being detuned by vibrations. The bandspread dials are available in three band calibrations. The amateur band is the standard calibration. Other calibrations must be specially ordered.

Table 1-3 lists the electron tube and semiconductor complement of the unit.

TABLE 1-1. REFERENCE DATA

CHARACTERISTIC	SPECIFICATION
Frequency range	0.54 to 32.3 mc divided into six tuning bands with the following ranges: Band 1: 0.54 to 1.4 mc Band 2: 1.4 to 3.3 mc Band 3: 3.3 to 5.6 mc Band 4: 5.6 to 9.5 mc Band 5: 9.5 to 17.5 mc Band 6: 17.3 to 32.3 mc
Tuning system	Accurately calibrated tuning and bandspread dials. (Electrical bandspreading on bands 2 through 6.)
Modes of reception	AM, AM equivalent, CW, MCW, SSB, ISB, FSK, and FAX
Method of tuning dial calibration	A crystal-controlled oscillator provides 100 kc markers throughout the tuning band
Noise figure and sensitivity	At least 10 db signal-plus-noise to noise with 1 uv input at 7.5 kc bandwidth, from 2 to 32 mc.
Image ratio	At least 60 db from 2 to 32 mc.
Selectivity	Six selectable i-f band-pass values are provided as follows: 15 kc, 7.5 kc, 3 kc, 2 kc, 1 kc, 0.5 kc.
I-f frequency	455 kc in tuning bands 1, 2, and 3. Double conversion from 3955 kc to 455 kc in bands 4, 5, and 6.

CHARACTERISTIC	SPECIFICATION
I-f rejection	At least 80 db throughout frequency range
Intermodulation	At least 35 db down
Avc	80 db rise in input signal from 1 microvolt will produce less than 2 db change in audio output.
Hum level	More than 50 db below rated output
Audio frequency response	Flat within 1.5 db from 150 to 8000 cps.
Antenna input impedance	72 ohms and 300 ohms unbalanced
I-f output	At least 10 millivolts rms into 50 ohms. Available through BNC connectors.
Audio output	1. 1 watt into 4, 8, or 16 ohms 2. 1 milliwatt into 600 ohms balanced load 3. Headphone output with PHONE LEVEL control
Primary power	115±10v or 230±20 v, 50 to 400 cps, 125 watts.
Temperature range	(122°F). 0°C(32°F) to 50°C
Dimensions	Length: 17 inches Width: 19 inches Height: 8-3/4 inches
Weight, uncrated	65 pounds

TABLE 1-2. EQUIPMENT SUPPLIED

NOTE

This table is applicable only when the GPR-92A is shipped as a single item.

NAME	DESIGNATION	FUNCTION	QUANTITY
General Purpose Receiver	GPR-92A	Communications receiver	1
Cable assembly*	CA-555-3	Ac power cord	1
Terminal board	TM-105-18AL	Back-panel wiring connections	1
Terminal board	TM-105-108AR	Back-panel wiring connections	1
Rf connector plug	UG88/U	Provides for coaxial cable connections to external equipment	6
Hex wrench	WR-100-2	Alignment tool	1
Hex wrench	WR-100-3	Alignment tool	1
Hex wrench	WR-100-4	Alignment tool	1
Socket wrench	TP-117-1	Alignment tool	1
Flat tipped Screwdriver	TP-116-1	Alignment tool	1

*This cable is available with four different terminations. A polarized 100 volt plug is standard; spade lugs, a 220 volt plug, or tinned leads can be provided upon request.

TABLE 1-3. ELECTRON TUBE AND DIODE COMPLEMENT

REFERENCE DESIGNATION	TYPE	FUNCTION
CR101	DD130-160-1.5	Rectifier
CR105	1N34A	AM detector
CR106	1N463	Noise limiter
CR107	1N34A	Rectifier
V101	OB2	Voltage regulator
V102	6CB6A	Marker (100 KC) oscillator
V103	6AB4	1st rf amplifier
V104	6BA6	2nd rf amplifier
V105	6EW6	Hfo isolation amplifier
V106	6BA7	1st mixer
V107	6AH6	High frequency oscillator
V108	6AU6A	Ifo isolation amplifier
V109	6U8A	Combination 2nd mixer, 1st i-f amplifier, and i-f oscillator
V110	6BA6	2nd i-f amplifier
V111	6AL5	Rf noise limiter
V112	6AZ8	Combination 3rd i-f amplifier and squelch amplifier
V113	6U8A	Combination i-f output (to external circuits) isolation amplifier, avc amplifier, and avc detector
V114	6BA6	4th i-f amplifier
V115	12AT7	Combination product detector and beat frequency oscillator
V116	6AB4	Isolation amplifier for external beat frequency oscillator
V117	12AX7A	Combination meter amplifier and audio driver
V118	6AQ5A	Audio output amplifier

SECTION 2 INSTALLATION

2-1. UNPACKING AND HANDLING.

The GPR-92A is shipped from the factory in a wooden crate to ensure maximum protection from damage in transit. The inside of the crate contains additional packing material to protect the unit not only from breakage due to shock, but also from the elements. Inspect all packing for parts shipped as loose items.

As soon as the GPR-92A is unpacked, it should be visually inspected to make sure that it is not damaged. This examination should include the testing of each front panel control for ease of operation. All of the covers on the unit should be removed, and the inside of the unit checked carefully for damaged components.

If any damage is found refer to the warranty at the front of the manual for instruction.

2-2. POWER REQUIREMENT.

The GPR-92A can operate with any ac input in the range of 90 to 125 volts and in the range of 180 to 250 volts. The receiver is normally shipped for operation on 115 vac. If the receiver is to operate from a power source other than 115 vac, the wiring to the primary windings of power transformer T101 must be modified. Figure 2-1 illustrates two of the possible connections (115 vac and 230 vac). It is recommended that a 1.5 ampere fuse be used on 115 volts and a .75 ampere fuse be used on 230 volts. The necessary connections for other input powers can be derived from the illustration.

2-3. INSTALLATION LAYOUT.

Regardless of whether the GPR-92A is contained in a cabinet, or is intended for rack mounting, consideration must be given, at the time of installation, to its ultimate location. Three factors are important.

a. **ACCESSIBILITY.** - The GPR-92A must be located so that an operator can comfortably reach all of the front panel controls. Sufficient clearance around the unit must be allowed so that the rear panel connections are easy to get at, and so that the unit can be removed for servicing. Sufficient bench space should be provided to allow the use of necessary test equipment to perform troubleshooting and alignment.

b. **VENTILATION.** - The electron tubes inside the GPR-92A generate heat. To prevent a heat built-up, sufficient clearance around the unit must be allowed to ensure that the air flow is not restricted.

c. **INTERFERENCE.** - To achieve the best possible operation of the GPR-92A, every attempt should be made to reduce rf interference from other equipment such as motor-generator sets.

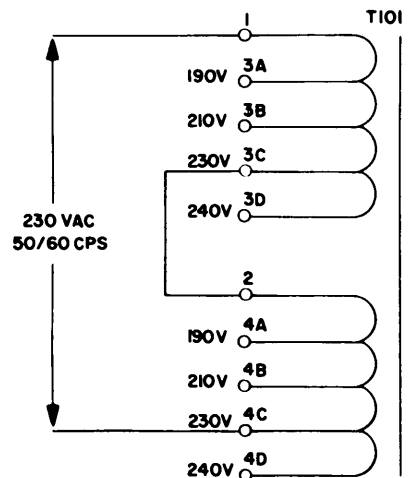
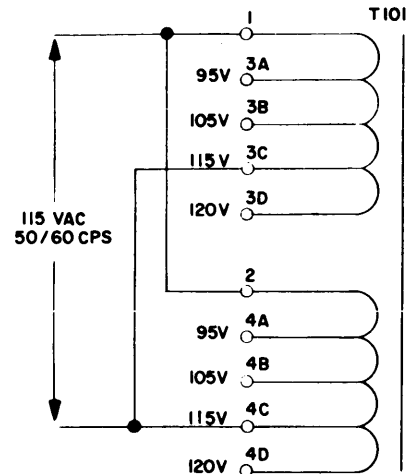

3006-2

Figure 2-1. Power Transformer Wiring.

2-4. INSTALLATION REQUIREMENTS.

The type of antenna to be used with the GPR-92A depends upon the application for which the receiver will be used. Consequently, the antenna must be selected and installed by the user. It should be noted that the GPR-92A has one 72-ohm and one 300-ohm antenna inputs at the rear of the unit. Figure 2-3 shows the input and output connections on the rear panel.

anced output is present all of the time as is the phone output. However, plugging in a set of ear phones automatically breaks the ground at the speaker O-ohm terminal. If the speaker and phone outputs are desired simultaneously, the speaker return must be connected to the GND terminal rather than the O-ohm terminal.

NOTE

All three of the audio outputs may or may not be produced simultaneously, depending upon how the speaker is wired. The 600 ohm bal-

2-5. PERFORMANCE CHECKS.

Immediately after the receiver has been installed and is operative, perform the checks given in paragraph 3-4.

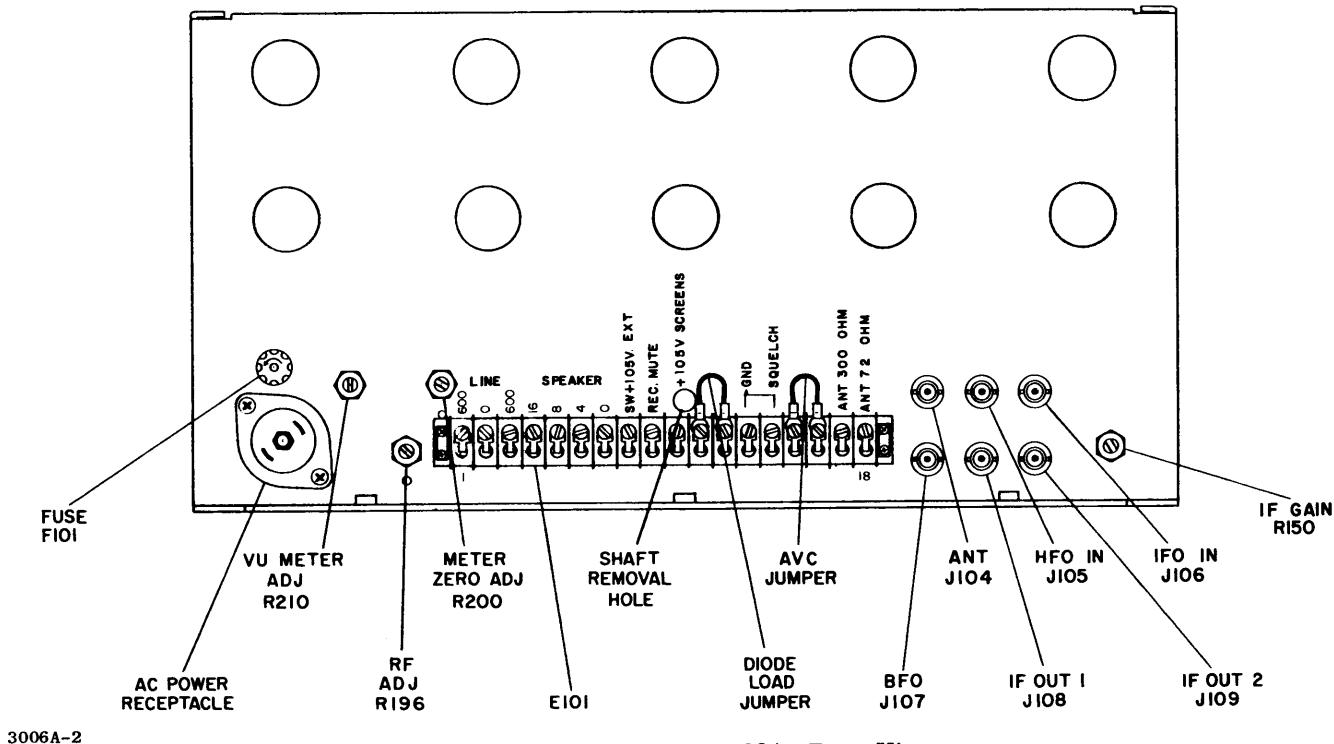

Figure 2-2. GPR-92A, Rear View

3006A-2

SECTION 3 OPERATOR'S SECTION

3-1. CONTROLS AND INDICATORS.

Before attempting to operate the GPR-92A, the operator should familiarize himself with all controls and indicators given in table 3-1. The index numbers listed in the table are those assigned in figure 3-1. Each description in the table indicates the

type of control or indicator and what its purpose is. It is important to stress that the descriptions are not operating procedures. For procedures applicable to particular controls or indicators, see paragraph 3-2. For the use of the controls and indicators in specific tuning procedures, see paragraph 3-3.

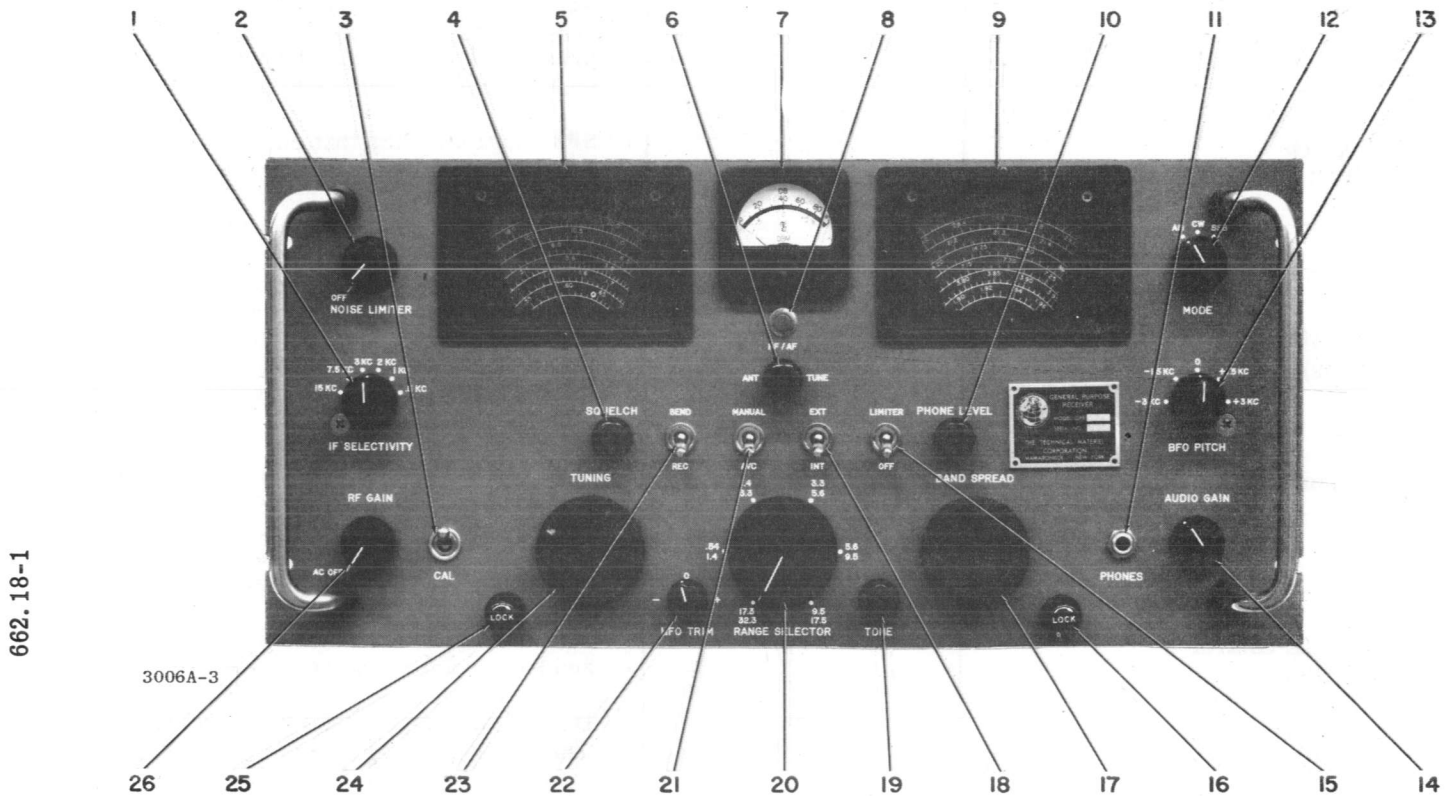

Figure 3-1. Controls and Indicators

TABLE 3-1. OPERATOR CONTROLS AND INDICATORS

CONTROL OR INDICATOR	INDEX NO.	DESCRIPTION
IF SELECTIVITY switch (S111)	1	Six-position rotary switch that selects the band-pass of the receiver. Positions are 15 KC, 7.5 KC, 3 KC, 2 KC, 1 KC, and .5 KC.
NOISE LIMITER control (S106, R157)	2	SPST switch ganged to potentiometer. Switch connects potentiometer into circuit. With potentiometer in circuit, noise pulses riding on i-f envelope are clipped. Turning control clockwise reduces recovery time of circuit and enables circuit to clip pulses at a lower level (and simultaneously clips peaks of the desired audio modulation.)
CAL switch (S103)	3	SPST toggle switch that energizes crystal-controlled 100 kc marker oscillator. Oscillator applies markers into receiver front end so that tuning dials can be calibrated at 100 kc check points.
SQUELCH control (R162)	4	Potentiometer that adjusts point to which the rf level must drop before the receiver is squelched (audio amplifier is disabled).
Main tuning dial	5	Calibrated dial with six bands plus log scale. Circles on the log scale correspond to the settings of the main tuning dial at which the bandspread dial scales are calibrated.
ANT TUNE control (C129)	6	Variable capacitor that tunes the 2nd RF circuit of the receiver
S meter (M101)	7	Dc milliammeter that has two scales. The upper scale indicates received rf level in db above 1 microvolt. The lower scale indicates audio power output in dbm (db above 1 milliwatt into 600 ohms).
RF/AF switch (S110)	8	Pushbutton switch that selects the input to the S meter. When it is pressed, the audio power output is indicated on the meter. When released, the rf signal level is indicated on the meter.
Bandspread dial	9	Calibrated dial with six bands plus a log scale. The 100 log setting corresponds to the circled points on the main tuning dial.

TABLE 3-1. OPERATOR CONTROLS AND INDICATORS (CONT)

CONTROL OR INDICATOR	INDEX NO.	DESCRIPTION
PHONE LEVEL control (R218)	10	Potentiometer that is connected in circuit only when headset is connected to PHONES jack. Potentiometer adjusts volume at headset.
PHONES jack (J103)	11	Standard phone jack for headset connection (standard 2-contact plug). Automatically disconnects speaker when headset is connected if speaker return is connected at 0-ohm terminal of E101. Connecting a headset does not interrupt the output to 600-ohm units or to speakers returned at GND terminal of E101.
MODE switch (S109)	12	Three-position rotary switch that selects the output of the AM detector (in AM) or the output of the product detector (in CW and SSB). In CW and SSB, the bfo or bfo isolation amplifier is energized. In SSB, additional filtering is provided for the avc buss.
BFO PITCH control (T133)	13	Slug-tuned transformer that tunes bfo from 3 kc below i-f center frequency to 3 kc above.
AUDIO GAIN control (R202)	14	Potentiometer that adjusts audio level applied to the internal audio amplifier. Controls audio output into speaker, 600-ohm line, or headset.
LIMITER switch (S108)	15	SPDT toggle switch that connects audio noise limiter circuit. This switch is effective only in AM mode.
LOCK control	16	Cam that wedges a friction brake against the flywheel of the BAND SPREAD control to prevent accidental detuning.
BAND SPREAD	17	Ganged variable capacitors that may be used to fine-tune the receiver or be used to provide precise tuning in six amateur bands (10 m, 15 m, 20 m, 40 m, 80 m, and 160 m). The BAND SPREAD control has no effect in the broadcast band; the variable capacitors are not in the circuit in this band.
INT-EXT switch (S105)	18	DPDT toggle switch that permits selection of internal or external oscillators for hfo (local oscillator), ifo (3500 kc), and bfo. Normally, the receiver is operated in INT; EXT is used in system applications requiring crystal controlled operation.

TABLE 3-1. OPERATOR CONTROLS AND INDICATORS (CONT)

CONTROL OR INDICATOR	INDEX NO.	DESCRIPTION
TONE control (R201)	19	Potentiometer that controls the high frequency cutoff of the audio amplifier.
RANGE SELECTOR switch (S102)	20	Six-position rotary switch that selects operating frequency band.
MANUAL-AVC switch (S107)	21	SPDT toggle switch that grounds avc buss in MANUAL so that gain is not automatically controlled or permits normal avc in AVC position.
HFO TRIM control (C189)	22	Variable capacitor that fine-tunes the internal hfo (local oscillator).
SEND-REC switch (S104)	23	SPDT toggle switch that permits automatic muting of the receiver from an associated transmitter. In SEND, it requires the transmitter to provide a ground connection for the receiver to operate. In REC, the ground connection is internally provided, and no external control is possible.
TUNING control (C153)	24	Ganged variable capacitors that tune the receiver in each frequency band.
LOCK control	25	Cam that wedges a friction brake against the flywheel of the TUNING control to prevent accidental detuning.
GAIN control (S101, R110)	26	SPST switch ganged to potentiometer. The switch is the power on-off switch of the receiver. The potentiometer adjusts the degenerative cathode bias (and hence the gain) of the first rf amplifier and the second and fourth amplifiers.

3-2. GENERAL OPERATING NOTES.

a. USE OF S METER.

(1) The upper scale of the S meter is calibrated to read input rf voltage directly in db above 1 microvolt. The calibration holds only when the RF GAIN control is set fully clockwise, and the receiver is accurately tuned to the incoming signal. The listing below provides the rf input voltage that is equivalent under these conditions to a reading on the upper scale:

0 db =	1.	microvolt
10 db =	3.16	microvolts
20 db =	10.	microvolts
30 db =	31.6	microvolts
40 db =	100.	microvolts
50 db =	316.	microvolts
60 db =	1,000.	microvolts = 1 millivolt
70 db =	3,160.	microvolts
80 db =	10,000.	microvolts = .01 volt

(2) For most types of signals optimum tuning is indicated by a peak on the db scale of the S meter. For FAX and FSK reception, the intelligence must be within the passband of the receiver, but the receiver tuning must be offset from the suppressed carrier frequencies. For these signals, the db scale can provide only an approximate indication of tuning; the method of tuning the receiver for these signals is given in paragraph 3-3.

(3) The lower scale of the receiver is calibrated to read the output audio level in dbm (db above 1 milliwatt into 600 ohms). When operating with telephone-type equipment (teletype, facsimile), the AUDIO GAIN control adjusts the audio output to a desired reference level (as read on the dbm scale) to balance the system.

(4) The S meter is also useful in the daily operating checks given in paragraph 3-4.

b. GENERAL TUNING PROCEDURE

(1) When tuning to a station whose frequency is known, but is not on the bandspread dial, follow the procedure given below:

(a) Turn receiver on by turning RF GAIN control clockwise from its OFF position. Allow receiver at least 30 minutes to warm up (for accurate dial calibration).

(b) Set the controls as follows:

NOISE LIMITER control:	OFF
IF SELECTIVITY switch:	15 KC
SQUELCH control:	Fully ccw
SEND-REC switch:	REC
MANUAL-AVC switch:	AVC
RANGE SELECTOR switch:	Desired band
BAND SPREAD control:	100 log on dial
EXT-INT switch:	INT
LIMITER-OFF switch:	OFF
MODE switch:	As applicable
BFO PITCH control:	0
HFO TRIM control:	0
RF GAIN control:	Fully cw

(c) After warm-up period, unlock the TUNING control and set tuning dial to 100-kc check point nearest desired frequency. For example, to listen to a station at 5.92 mc, set main tuning dial at 5.9.

(d) Set CAL switch to the up position and adjust HFO TRIM for a maximum indication on S meter. Set CAL switch to the down position.

(e) Adjust TUNING control to desired frequency as indicated on the dial.

(f) If the receiver is tuned to a station that is transmitting, a deflection will be seen on the S meter. Adjust the ANT TUNE control to peak indication on S meter.

(g) Adjust TUNING control for peak indication on S meter. Then increase frequency setting to decrease the reading slightly below its peak value. Then unlock BAND SPREAD control and decrease its setting below 100 log until S meter reading is again at peak value.

(h) Lock the TUNING and BAND SPREAD controls.

(i) Refer to paragraph 3-3 for specific tuning procedures for each type of reception.

(2) When tuning to a station whose frequency is known, and is on the bandspread dial, follow the procedure given below:

(a) Perform steps (1) (a) and (b) above.

(b) After warm-up period, set main tuning dial at desired circle on the log scale.

NOTE

The circles on the log scale correspond to the upper frequency end of the amateur bands. They mark the settings of the TUNING control at which the bandspread scales were calibrated.

(c) Set RANGE SELECTOR switch for correct frequency range:

160 m	1.4	-	3.3
80 m	3.3	-	5.6
40 m	5.6	-	9.5
20 m	9.5	-	17.5
15 m	17.3	-	32.3
10 m	17.3	-	32.3

(d) See that bandspread dial is exactly at 100 log.

(e) Set CAL switch to the up position, and adjust TUNING control, if necessary to obtain a peak indication on S meter at the desired circle. Set CAL switch to the down position and lock TUNING control.

(f) Set bandspread dial exactly on the nearest 100-kc check point. Note that this setting might not be at peak indication on S meter.

(g) Set CAL switch to the up position and adjust HFO TRIM control for a peak indication on S meter. This calibrates the bandspread dial at this point. Set CAL switch to the down position.

(h) Turn BAND SPREAD control until the dial reads the frequency of the station.

(i) If the station is transmitting, adjust ANT TUNE control to peak the indication on S meter.

(j) If necessary, adjust BAND SPREAD control slightly to bring in the station stronger. Lock the control.

(k) Refer to paragraph 3-3 for specific tuning procedures for each type of reception.

(3) When tuning to a station whose frequency is not known, follow the procedure given below:

(a) Perform steps (1) (a) and (b) above.

(b) Unlock TUNING control and adjust it slowly through the frequency band while observing the S meter.

(c) When S-meter indication is observed, adjust TUNING control to peak the indication.

(d) Turn AUDIO GAIN until audio signal at phones or speaker is at desired level.

(e) Set MODE switch to each position, if necessary, to determine the type of signal being received. Note that S meter indications fluctuate with voice level on SSB.

(f) Refer to paragraph 3-3 for specific tuning procedures for each type of reception.

c. OPTIMUM SETTING OF CONTROLS. - The best setting of some controls is a compromise between two considerations. These are discussed in the following paragraphs.

(1) NOISE LIMITER. - This control should be left at OFF unless noise is bothersome. Then turn it clockwise only enough to reduce the noise to a tolerable level. Setting the control too high might distort the audio signal slightly.

(2) SQUELCH. - This control may be set clockwise when the signal that is to be received is strong. When tuning to weak signals, the control should be fully counterclockwise so that the weak signals are not lost. (Also, see paragraph (6) below.)

(3) IF SELECTIVITY. - This control should be set to the position required for the type of signal being received. To reduce noise or adjacent station interference, the switch can be set for a narrower bandwidth. This results in degradation of fidelity.

(4) RF GAIN. - This control should be set fully clockwise to provide best signal-to-noise ratio. When operating without avc (in MANUAL) or in close proximity to the transmitting station, it will be necessary to reduce the RF GAIN setting to prevent overdriving the receiver.

(5) AUDIO GAIN. - This control may be set to any convenient point when the receiver is operating into a speaker or headset, but should not be turned from its adjusted position when operating into telephone-type equipment.

(6) MANUAL-AVC. - This switch should be set at AVC except when receiving any interrupted carrier signal, such as CW. With avc, the gain of the receiver increases between characters. If keying occurs at a slow rate, the increase in gain might be sufficient to bring the noise up to a bothersome level. In this case, set switch at MANUAL and control the gain with the RF GAIN control. In MANUAL, the gain of the receiver is the same between the characters as it is when the characters are received. However, it will be necessary to adjust the RF GAIN control from time to time to compensate for variations in received signal strength. Because the S meter operates off the avc level in RF, it is necessary to switch from MANUAL to AVC before retuning the receiver. Also, the absence of avc will squelch the receiver; set the SQUELCH control fully ccw when operating in MANUAL.

(7) LIMITER-OFF. - This switch affects reception only in the AM mode. It should be set at OFF, except when noise is bothersome. Setting the switch at LIMITER will reduce noise and distort audio signals slightly.

3-3. TUNING PROCEDURES.

a. AM RECEPTION (VOICE).

(1) Set AUDIO GAIN control fully counterclockwise so that speaker or headset is silenced during tuning. Follow the tuning procedures given in paragraph 3-2 b with the MODE switch at AM.

(2) Increase setting of AUDIO GAIN to a comfortable level. If necessary, readjust BAND SPREAD control for best sound, and lock the control.

(3) If a speaker and headset are used interchangeably, set AUDIO GAIN for speaker level and then set PHONE LEVEL for headset.

(4) Adjust TONE control to make the output more or less treble as desired.

(5) If noise is bothersome, set LIMITER switch at LIMITER. If additional noise limiting is needed, turn NOISE LIMITER control clockwise until optimum setting is reached.

b. AME RECEPTION. - Follow same procedure as in a above.

c. MCW RECEPTION. - Follow the same procedure as in a above, except set IF SELECTIVITY to 2 KC after tuning to limit noise without affection reception. Additional noise limiting may be achieved as in a.

d. CW RECEPTION.

(1) Set AUDIO GAIN counterclockwise to silence the receiver while tuning. Follow the tuning procedure given in paragraph 3-2b with the MODE switch set at CW.

(2) Set BFO PITCH control for a comfortable tone when the station is transmitting.

(3) Set IF SELECTIVITY switch at 1 KC. If necessary to reduce noise, set the switch to .5 KC. If additional noise limiting is needed, turn NOISE LIMITER control clockwise until noise is reduced to a tolerable level.

e. SSB RECEPTION (VOICE). - Follow tuning procedure given in paragraph 3-2b with the MODE switch set at SSB. Note the following differences:

(1) Set the IF SELECTIVITY switch to 7.5 KC.

(2) Tune above the carrier frequency to receive upper sideband signals or below the carrier frequency to receive lower sideband signals. Use S meter as a tuning indicator and tune for peak indication. Note that the absence of a carrier causes S meter indications to fluctuate with voice level.

(3) Adjust BAND SPREAD control for the most intelligible speech reception. Lock the control. Use BFO PITCH control as a "fine-tuning" for SSB signals.

(4) Reduce the setting of the IF SELECTIVITY

switch for the best noise reduction with least degradation of speech:

(5) If additional noise limiting is needed, turn NOISE LIMITER control clockwise until the noise is reduced to a tolerable level.

f. SSB RECEPTION (FAX). - Follow the procedure given below.

(1) Turn on the receiver and set the controls as described in paragraph 3-2b, steps (1) and (2). Set MODE switch SSB.

(2) After warm-up period, unlock TUNING control and set tuning dial to 100-kc check point nearest the desired frequency.

(3) Set CAL switch to the up position and adjust HFO TRIM for maximum indication on S meter. Set CAL switch to the down position.

(4) Adjust TUNING control to desired frequency as read on the dial.

(5) Adjust TUNING and ANT TUNE controls to peak the reading on the S meter. Note the reading.

(6) Set IF SELECTIVITY switch at 1 KC.

(7) Reduce the setting of the bandspread dial slightly below 100 log until S meter reading drops approximately 8 db below the value noted in step 5. Lock the TUNING and BAND SPREAD controls.

(8) Set the IF SELECTIVITY switch to 3 KC.

(9) Connect an audio oscillator to horizontal input of an oscilloscope. Connect audio output of the receiver to the vertical input.

(10) Set audio oscillator frequency at 1,500 cps.

(11) Set BFO PITCH control slightly off 0 (to about .9 kc) until an unsteady, but 1:1 Lissajous pattern is observed. This corresponds to the white areas in the picture, which are not continuously transmitted.

(12) Set the audio oscillator frequency at 2,300 cps and check that the circular pattern is observed again. This corresponds to the black areas in the picture.

NOTE

If the 1:1 pattern is not obtained at 2,300 cps, reset the audio oscillator frequency to 1,500 cps. Reset the BFO PITCH control to another setting (there should be only one other setting) at which the 1:1 pattern reappears. Then recheck the setting by repeating step (12).

h. SSB RECEPTION (ISB). - For ISB reception, the GPR-92A must be used with other equipment that separates the two sidebands into two channels. The separate channels can be provided by connecting a sideband converter such as TMC model SBC-1 to either of the IF OUT jacks, or by two sideband

adapters such as TMC model GSB-1 connected to the two IF OUT jacks. The GPR-92A is used to tune to the center frequency of the desired signal, but the audio output of the GPR-92A is not used. Proceed as follows.

(1) Turn on the receiver and set the controls as described in paragraph 3-2b, steps (1) and (2). Set MODE switch at SSB.

(2) After warm-up period, unlock TUNING control and set tuning dial to 100-kc check point nearest the desired frequency.

(3) Set CAL switch to the up position and adjust HFO TRIM for maximum indication on S meter. Set CAL switch to the down position.

(4) Adjust TUNING control to desired frequency as read on the dial.

(5) Adjust TUNING and ANT TUNE controls to peak the reading on the S meter.

(6) Use the BAND SPREAD control as a receiver clarifier control for the ISB outputs.

(7) If noise is bothersome, adjust NOISE LIMITER control clockwise to reduce noise to tolerable level. Normally IF SELECTIVITY should be left at 7.5 KC. If necessary for additional noise limiting, reduce IF SELECTIVITY setting below 7.5 KC, but this will eliminate the upper frequencies in both sidebands.

NOTE

The following controls, that could be used for other SSB signals, have no effect in ISB reception:

BFO PITCH
AUDIO GAIN (set ccw)
TONE
PHONE LEVEL

3-4. OPERATOR'S CHECKS.

a. Check each mode of operation (AM, CW, SSB) on at least one of the six frequency bands.

b. Check reception in any mode on all six of the frequency bands.

c. Check the receiver, using the internal calibrator as follows:

(1) Tune the receiver to a 100-kc check point in band 1. Set the MODE switch to CW.

(2) Set CAL switch to the up position and adjust HFO TRIM for a peak reading on the S meter. Compare this value with the value that was recorded after installation or after alignment.

(3) Set the BFO PITCH to +1.5 KC and hold the CAL and RF/AF switches depressed. Compare

the dbm reading with the recorded value.

(4) Repeat steps (1), (2), and (3) for each of the other bands.

d. Check each operator's control for ease of operation.

e. Using a reliable tube tester, check condition of electron tubes. Visually check for blown fuses.

NOTE

The power fuse is on the rear panel. If a replacement fuse blows, troubleshooting is required.

Do not replace tubes merely because they are old. Replacement might require re-alignment of that circuit.

SECTION 4

PRINCIPLES OF OPERATION

4-1. GENERAL.

This section explains the principles of operation of the General Purpose Receiver GPR-92A as an independently operated communications receiver. This section does not describe TMC accessory units that may be combined with the GPR-92A to expand its utility. A description of such combinations is explained in the applicable system operating manuals.

4-2. BLOCK DIAGRAM THEORY.

(See figure 4-1.)

a. RF STAGES.

(1) Received rf signals from the antenna are applied from J104 or E101 to a two-stage rf amplifier. Rf amplifiers V103 and V104 provide the necessary image rejection of 80 db throughout the frequency range of the receiver. The rf amplifiers are tuned by the TUNING control, and fine-tuned by the BAND SPREAD control. The output of V104 is applied to the first mixer V106.

(2) The RF GAIN control adjusts the common cathode bias for the first rf amplifier and the second and fourth i-f amplifiers. When S104 is set at SEND (so that the receiver is controlled by an associated transmitter), these gain-controlled stages are disabled by removal of the cathode-return to ground when the transmitter carrier is on (for example, when keyed). When the carrier is off, the transmitter provides a ground return to these stages through the SEND position of S104.

b. LOCAL OSCILLATOR AND MIXERS.

(1) In the three lowest frequency bands (.54 - 5.6 mc) hf oscillator V107 is operated 455 kc above the received rf signal, and the output of first mixer V106 is 455 kc. In these bands, RANGE SELECTOR S102 removes +105V from ifo isolation amplifier V108 and i-f oscillator V109B. Therefore, the only input to V109A is the 455 kc output of the first mixer; under these conditions, V109A operates as the first i-f amplifier.

(2) In the three highest frequency bands (5.6 - 32.3 mc) hf-oscillator V107 is operated 3955 kc above the received rf signal and the output of the first mixer is 3955 kc. In these bands, i-f oscillator V109B is energized and provides a 3500 kc input to V109A, which operates as a second mixer,

producing the i-f frequency of 455 kc.

(3) By operating the local oscillator at a difference frequency of 3955 kc in the higher frequency bands, the separation of the image frequency from the received signal is increased. In the lower bands, the image frequency occurs at 910 kc above the received signal ($910 = 455 \times 2$); in the upper bands, the image frequency occurs at 7910 kc above the received signal. This increased frequency separation simplifies image rejection.

(4) When external oscillators are used, switch S105 is set at EXT. In this position, the switch removes +105 volts from hf oscillator V107 and from i-f oscillator V109B, and applies it instead to hf isolation amplifier V105 (in all frequency bands) and to ifo isolation amplifier V108 (in the three highest frequency bands). The isolation amplifiers provide low input impedances to match coaxial cables.

c. I-F AMPLIFIERS AND AVC.

(1) The second, third, and fourth i-f amplifiers V110, V112A, and V114 are tuned to 455 kc. The bandpass of the i-f amplifier strip may be set to any of six values (between .5 kc and 15 kc) by the IF SELECTIVITY switch; this switch affects the interstage coupling circuit between the second and third i-f amplifiers.

(2) The i-f output of third i-f amplifier V112A is connected to a noise limiter which removes any rf spikes that are received. The noise-limited output of the third i-f amplifier is applied to fourth i-f amplifier V114 and to i-f output and avc amplifier V113A.

(3) One output of V113A is available at IF OUT jacks J108 and J109. The other output of V113A is rectified to provide a delayed avc voltage. When the AVC terminals on E101 are jumpered, this avc voltage is applied to the first and second rf amplifiers and the second, third, and fourth i-f amplifiers to stabilize the receiver output in spite of variations in the received rf signal level. In diversity operation, the AVC terminals of two (or more) receivers are connected together so that the receiver obtaining the stronger rf signal produces the larger avc voltage and reduces gain in the other receiver. This reduces the noise that would otherwise be generated in the receiver with no signal or only a weak one.

(4) The third i-f amplifier also generates a dc output that is determined by its avc input. The dc output is applied to squelch tube V112B. When the rf signal level drops, as it would when tuning between stations, this dc output cuts off squelch tube V112B, which disables audio driver V117B and thereby prevents the amplified noise from being applied to the receiver output. In diversity operation, the presence of an externally applied avc voltage prevents squelching when the rf signal to one of the receivers fades.

d. DETECTORS.

(1) The output of fourth i-f amplifier V114 is applied to two detectors. AM, compatible AM (AM equivalent), and MCW signals are detected by AM detector CR105. When the diode load terminals of E101 are jumpered, the detected output is applied to noise limiter CR106 and through the AM position of MODE switch S106 to audio driver V117B. In diversity operation, the outputs of each receiver's AM detector are connected together and may be applied to an external or internal audio amplifier.

(2) CW and all suppressed carrier signals (single sideband, frequency shift keying, facsimile, and independent sideband) are detected by product detector V115A. The applied signal is mixed with the output of bfo V115B (when using internal oscillators) or bfo isolation amplifier V116 (when using external oscillators). In single sideband, the bfo is set to the i-f frequency to beat with the sideband frequencies and produce the audio frequency. In CW, the bfo (internal or external) is tuned away from the i-f frequency to produce an adjustable tone output. In the reception of other suppressed carrier signals, the bfo can be offset to produce the correct frequency outputs. The output of the product detector is applied through the CW or SSB position of the MODE switch to the audio amplifier.

e. AUDIO AMPLIFIER. - The audio amplifier consists of audio driver V117B and audio output V118. The amplified output can be connected to speakers with impedances of 16, 8, or 4 ohms, to headphones, or to a balanced 600-ohm line. The audio amplifier is squelched in the absence of a minimum (adjustable) avc level (see paragraph c (4) above.).

f. S METER. - The front panel "S" meter reads either the avc level or the audio output level. The signal that is selected by RF/AF switch S110 is applied to meter amplifier V117A, which drives the meter. The meter is a dc meter with two scales. The upper scale is calibrated in db above 1 microvolt and is used in the RF position of the switch. The lower scale is calibrated in dbm (db above 1 milliwatt in 600 ohms) and is used when the switch is held in the AF position.

g. CALIBRATION. - Marker oscillator V102 is energized when CAL switch S103 is turned on. The oscillator is an electron coupled 100 kc crystal controlled oscillator whose output is rich in har-

monics of 100 kc. The output is connected to first rf amplifier V103. The harmonic that is closest to the tuning of the rf amplifiers is amplified more than the adjacent harmonics. The selected harmonic is used to calibrate the bandspread dial at 100-kc check points. (The bandspread dial is set at the check point closest to the desired frequency, the CAL switch is pressed, and the hf oscillator is trimmed to provide the maximum reading on the db scale of the S meter.)

h. POWER SUPPLY. - The power supply provides a +250 volt unregulated output and a +105 volt regulated output that is derived from the +250 volt circuit. The power switch is ganged to the RF GAIN control so that the receiver is turned off when the control is turned fully counterclockwise.

4-3. CIRCUIT ANALYSIS.

(See figure 7-1.)

a. GENERAL. - Most of the circuits in the receiver are standard circuits that can be easily recognized on the schematic diagram. Therefore the circuit analysis that follows describes only those areas that are unusual, complex, or not immediately evident upon inspection of the schematic diagram.

b. RF STAGES.

(1) The antenna may be connected by coaxial cable to J104 or by twin lead to ANT terminals on E101. The received signal is applied across a series of low-pass filter networks selected by sections A and B of RANGE SELECTOR S102 and then fed to broad band (grounded grid) amplifier V103.

(2) When switch S104 is in the REC position, the combined tube current of the first rf (V103), second i-f (V110), and fourth i-f amplifiers (V114) flows through RF GAIN control R110. Turning R110 clockwise decreases the resistance in the circuit, decreases the cathode bias for these three stages, and therefore increases the gain of these stages. When switch S104 is set at SEND, a cathode ground is controlled by an associated transmitter. The cathode ground is removed when the transmitter is on the air, and the current from the three gain-controlled stages charges capacitor C134 and cuts off the three stages.

(3) The plate circuit of the first rf amplifier is selected by the front section of S102-C and consists either of a transformer with a tuned secondary (on the three lowest frequency bands) or of capacitive coupling to a tuned circuit (on the three highest frequency bands). Each circuit is slug-tuned and capacitively trimmed for optimum performance throughout the band. The outputs of the five circuits that are not selected are shorted to ground through S102-D rear. S102D rear and S102-D front

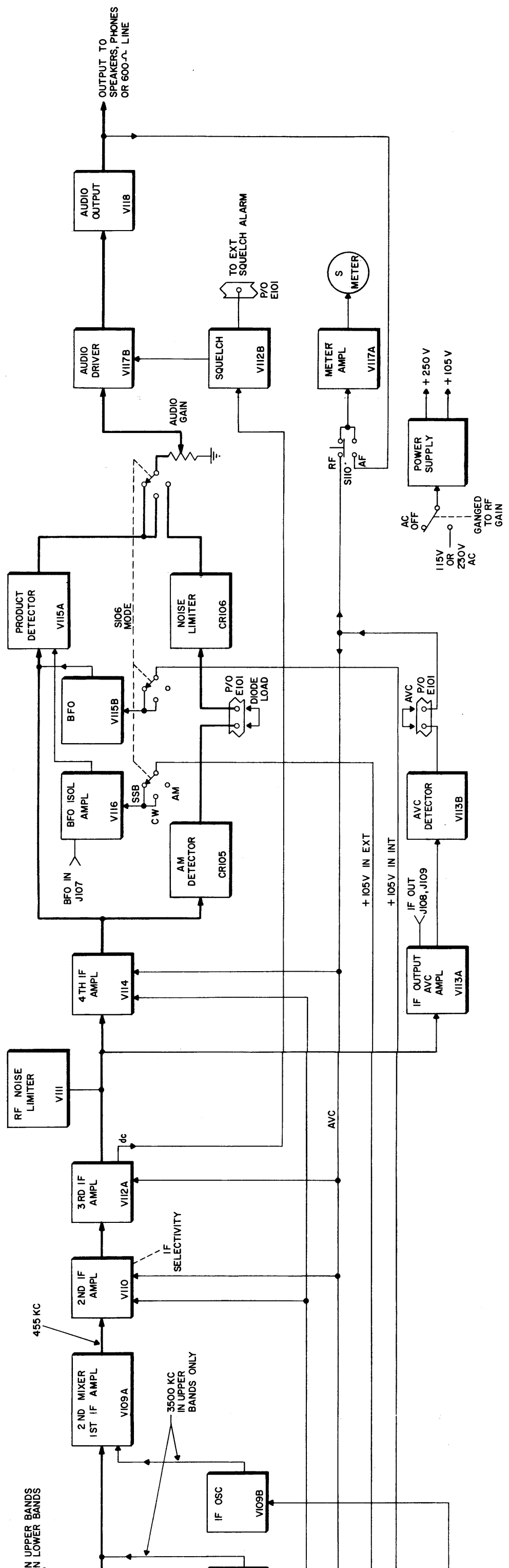
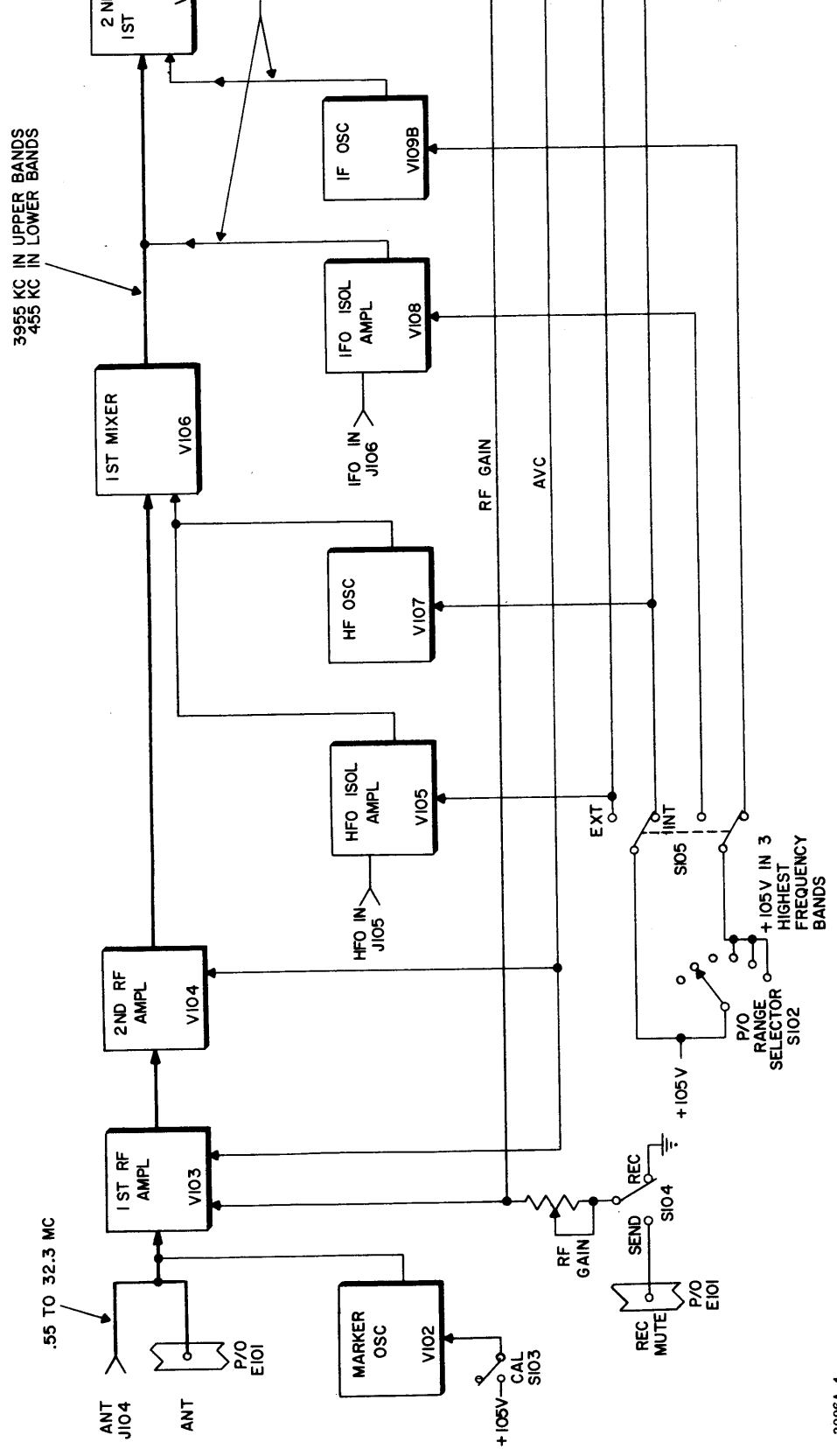

Figure 4-1. General Purpose Receiver GPR-92A, Block Diagram

4-3/4-4

004663006A



connect the selected circuit in parallel with sections of main tuning capacitor C153A, bandspread capacitor C152A and ANT TUNE capacitor C129. Note that the bandspread capacitor is not connected in band 1 and thus the BANDSPREAD control is not used in this band.

(4) The tuned circuits for second rf amplifier V104 are selected in the same manner as are those of the first rf amplifier. The output of the V104 is applied to the signal grid of first mixer V106.

c. LOCAL OSCILLATOR AND MIXERS. - The local oscillator and mixer circuit (figure 7-1) consists of hf oscillator V107, hfo isolation amplifier V105, and first mixer V106. Mixer V106 receives the local oscillator signal from either hf oscillator V107 or hfo isolation amplifier V105 and receives the signal input from second rf amplifier V104. The circuit is controlled by EXT-INT switch S105, which determines whether V107 or V105 is energized, and by RANGE SELECTOR switch S102, which determines the tuning of the hf oscillator and of the first mixer; the first mixer is tuned to 455 kc in the three lowest frequency bands and to 3955 kc in the three highest.

(1) Hf oscillator V107 is energized when S105 is set at INT; V107 is used as a triode-connected pentode in a standard Hartley circuit. The cathode of V107 is connected through S102-H (front) to the tap on a tuned-circuit inductor. The selected inductor is slug-tuned and capacitively trimmed for optimum tracking through its band. The selection of the tuning capacitors is the same as in the rf amplifiers (paragraph 4-3b). HFO TRIM capacitor C189 is connected in parallel with the selected tuning capacitors to tune the local oscillator at a 100-kc check point to calibrate the bandspread dial, in the vicinity of that check point.

(2) HFO isolation amplifier V105 is an untuned wide-band amplifier that serves as a buffer for an externally applied local oscillator signal. V105 is energized only when S105 is set at EXT.

(3) The output from either V105 or V107 is applied to first mixer V106, and is mixed with the output of second rf amplifier V104. The load for the mixer V106 is tuned transformer T125 or T122. The primary windings of these transformers are connected in series, but S102-G (front) shorts one of the two primary windings so that the other winding is effectively the only load for the mixer. In the three lowest frequency bands (.54 - 5.6 mc) S102-G shorts out T125; thus T122, which is tuned to 455 kc, tunes mixer V106 to 455 kc. In the three highest frequency bands (5.6 - 32.3 mc), T122 is shorted out and T125 tunes the mixer to 3955 kc.

d. I-F AMPLIFIERS AND AVC. - The i-f amplifier and avc circuit (figure 7-1) consists of i-f oscillator V109B and ifo isolation amplifier V108; second mixer and first i-f amplifier V109A; second, third, and fourth i-f amplifiers V110, V112A, and V114; bandpass filter FL102; noise limiter V111; squelch tube V112B; i-f output and avc amplifier

V113A; and avc detector V113B.

(1) The input to second mixer and first i-f amplifier V109A depends on the frequency band in which the receiver is operating and on the selection of internal or external oscillators. The secondary windings of transformers T122, T125, and T129 are connected in series; the sum of the secondary voltages (some of which are zero under particular operating conditions) is applied to the grid of V109A. When the receiver is operating in any of the three lowest frequency bands, RANGE SELECTOR switch S102-G (rear) removes +105 volts from both i-f oscillator V109B and ifo isolation amplifier V108. Because V108 is deenergized, no voltage appears across T129; in the three lowest frequency bands, no voltage appears across T125 (paragraph c(3) above); thus only T122 provides an input (455 kc) to V109A.

(2) When the receiver is operating in any of the three highest frequency bands, switch S105 determines whether i-f oscillator V109B or ifo isolation amplifier V108 is energized. When S105 is set at EXT, +105 volts is applied through S102-G (rear) and S105 to ifo isolation amplifier V108, which serves as a buffer amplifier for an externally applied 3500 kc signal. V108 is tuned to 3500 kc by slug-tuned transformer T129. In these frequency bands, no voltage appears across T122; the 3500 kc signal from T129 and the 3955 kc signal across T125 are applied to the first mixer.

(3) When the receiver is operating in any of the three highest frequency bands and S105 is set at INT, +105 volts is removed from ifo isolation amplifier V108 and is applied instead to i-f oscillator V109B. Under these conditions, no voltage exists across T122 and none across T129; the only input to the grid of V109A is the 3955 kc signal across T125. I-f oscillator V109B is a crystal-controlled Colpitts circuit that is tuned to 3500 kc. The oscillator output is connected to the cathode of V109A.

(4) In the three lowest frequency bands, (in INT or EXT) V108 and V109B are deenergized. The only input to V109A is the 455 kc output of the first mixer (V106). Therefore V109A, which is tuned to 455 kc in all bands, serves as the first i-f amplifier. In the three highest frequency bands, the 3955 kc output of the first mixer is applied to V109A and is mixed with the 3500 kc output of V108 or V109B. The plate circuit of V109A is tuned to 455 kc and selects the difference frequency of 455 kc.

(5) The second i-f amplifier operates with avc. Its gain is further adjusted by RF GAIN control R110, which is mounted on the front panel, and by IF GAIN control R150, which is mounted on the rear panel. The effective range of the RF GAIN control is adjusted by the IF GAIN control.

(6) The output of the second i-f amplifier is coupled through filter FL102 to the third i-f am-

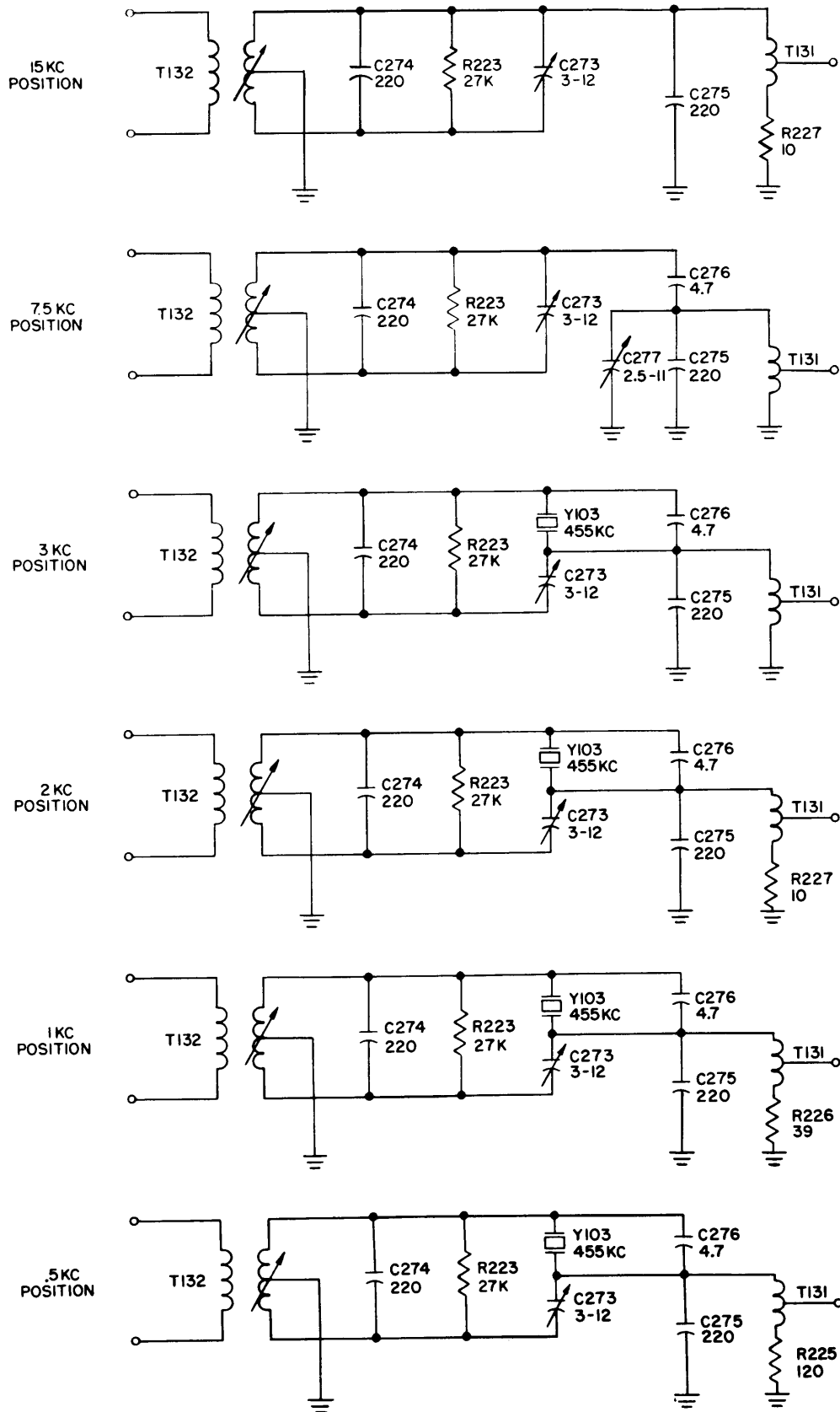

3006-6

Figure 4-2. I-F Filter FL102

plifier is coupled through filter FL102 to the third i-f amplifier. The FL102 circuit is controlled by IF SELECTIVITY switch S1, which is a six-position rotary switch. Figure 4-2 shows the circuit of FL102 in each of the six positions of the switch. It can be seen in this figure that the 15 KC and 7.5 KC positions do not utilize crystal Y103, and are therefore more broadly tuned than the other positions. The 7.5 KC position achieves a narrower bandpass than the 15 KC position because T131 is tuned with trimmer C277. In the 3 KC, 2 KC, 1 KC, and .5 KC positions, the difference in the bandpass is obtained by reducing the loading; this is accomplished by adding more resistance in series with T131.

(7) The output of filter FL102 is coupled to the grid of third i-f amplifier V112A. The i-f output of V112A is noise-limited by V111 (see paragraph (8) below) and coupled through T126 to V113A, the i-f output and avc amplifier (paragraph (10) below), and to V114, the fourth i-f amplifier (paragraph (11) below). The dc screen voltage of V112A is the signal input to the squelch circuit (paragraph (9) below).

(8) The noise limiter circuit (consisting primarily of dual diode V111 and switch S106) is connected across the tuned primary winding of T126. The i-f voltage across the winding (TP50 to T48) is alternately positive and negative. On the positive half-cycle, capacitor C233 is charged to the positive peak i-f voltage, and on the negative half-cycle C235 is charged to the negative peak i-f voltage; C232 is charged to the peak-to-peak voltage. If S106 is set at OFF, there is no discharge path for these capacitors and both diodes remain cut off by the charge on the capacitors. When an unusually large spike of rf (of either polarity) occurs, one or the other diode conducts, charging the associated capacitors to the higher voltage. Thus the capacitors retain their maximum charge and keep the diodes from conducting, and the circuit therefore has no significant effect. If S106 is turned clockwise from the OFF position, however, the capacitors can discharge between successive spikes so that each spike would be clipped at the capacitor voltage level. In this case, the discharge time constant and therefore the clipping level and the recovery time following a noise spike are adjusted by R157, which is ganged to S106.

(9) The dc screen grid voltage of V112A is an indication of received signal strength because the tube operates with avc. The stronger the received signal, the more negative the avc voltage, and the more positive the screen grid voltage. With normal signal levels, the screen grid is sufficiently positive (approaching +105V) so that only a small bias voltage is applied to V112B. V112B conducts heavily and K101 is energized, connecting ground to audio driver V117B. When the signal strength drops sufficiently, so does the screen grid voltage; the voltage at the wiper of R162 is lowered, conduction in V112B is reduced, and K101 is deenergized. The point at which K101 deenergizes is ad-

justed by SQUELCH control R162. With R162 set fully counterclockwise, K101 deenergizes when the received signal drops to a minimum value; the receiver can be squelched at higher levels by turning R162 clockwise.

(10) The i-f signal applied to V113A is amplified and is applied to avc detector V113B and to IF OUT jacks J108 and J109. The avc detector is a diode-connected triode that conducts on positive half-cycles of the applied i-f voltage. The negative half-cycles are filtered by R173, R174, C244, and C247 and applied to the AVC terminal 16 on E101. Additional filtering is provided by C255 when S109 is in SSB; the additional filtering is needed to reduce the fluctuations that occur on suppressed-carrier signals. When terminal 16 is jumpered to terminal 15, the avc voltage is applied to the S meter circuit (paragraph g) and to the avc buss of the receiver. When the AVC terminals of two GPR-92A receivers are connected together, the resultant avc voltage is the average of the two instantaneous avc voltages produced. Because this resultant is higher than the avc voltage that would otherwise be produced in the receiver with the weaker input, it decreases the gain in that receiver and prevents it from amplifying noise. Simultaneously, it increases the gain in the receiver with the stronger input. The action is regenerative so that only a small difference in received signal strengths is needed to "silence" the weaker-signal receiver.

(11) The noise-limited output of third i-f amplifier V112A is applied through T126 and T127 to fourth i-f amplifier V114. V114 operates with avc and its cathode is returned to the ground through the RF GAIN potentiometer. The i-f output of V114 is applied to the AM detector and to the product detector stage.

e. DETECTORS. - The i-f output from fourth i-f amplifier V114 is applied to two detector circuits (figure 7-1). The output of the circuit consisting of AM detector CR105 and noise limiter R185 through R188 is applied to the audio amplifiers when MODE switch S109 is set at AM; the output of the circuit consisting of product detector V115A, bfo V115B, and bfo isolation amplifier V116 is applied to the audio amplifiers when MODE switch S109 is set at CW or SSB.

(1) The i-f output of V114 is coupled through T130 to the AM detector. The positive half-cycles are clipped by CR105; the negative half-cycles are filtered by C248, C249, and R179 to remove the i-f frequencies. When the DIODE LOAD terminals of E101 are jumpered, the filtered output is applied to the audio noise limiter circuit. When S108 is at OFF, the noise limiter circuit consists of two voltage dividers R186-R185 and R187-R188. Because each divider halves the applied voltage, the voltage across the diode is zero and the diode has no effect. When S108 is at LIMITER, capacitor C253 is charged almost to the peak negative voltage appearing at the junction of R186-R185 and R187-R188. If a negative noise spike appears, the voltage at the

junction of R187-R188 tends to rise toward the peak of the spike voltage, while the junction of R186-R185 is at the capacitor voltage; diode CR106 conducts and clips the noise spike at the capacitor voltage. The noise limited audio signal is applied to MODE switch S109.

(2) The bfo, V115B, is a modified Hartley oscillator that is energized only when S109 is at CW or SSB and S105 is at INT. The bfo output is coupled to the grid of the product detector V115A.

(3) When S109 is at CW or SSB and S105 is at EXT, bfo isolation amplifier V116 is energized. An external bfo signal from J107 is then coupled through V116 to the cathode of the product detector.

(4) The i-f signal that is applied to the product detector is either an interrupted carrier without sidebands (CW) or one of several suppressed-carrier signals (eg. SSB). It is necessary to beat cw signals with a bfo signal that differs slightly from the i-f carrier to produce an audible tone (difference frequency). For suppressed-carrier signals, it is necessary to restore the carrier at or displaced from its equivalent i-f frequency. The bfo signal from V115B or from V116 is applied to, and modulates the current in product detector V115A. This modulation, in addition to the modulation produced by the i-f signal produces heterodyning and the resulting four frequencies (both inputs, their sum, and their difference). The filter consisting of C250, C254, and R189 selects the low difference frequency, which is applied to S109.

f. AUDIO AMPLIFIERS.

(1) The demodulated signal selected by MODE switch S109 is applied to the grid of audio driver V117B. The input signal is applied across the tone adjusting circuit consisting of TONE control R201 and capacitor C267. The high-frequency shunting of C267 is reduced by inserting more of the resistance of R201 in the circuit. The signal is applied across AUDIO GAIN control R202 and an adjustable portion is applied to the grid of V117B, the audio driver tube. The cathode of V117B is biased by a fixed positive voltage from divider R205-R206 and by cathode bias components R204 and C262. When the receiver is squelched, the fixed voltage cuts off V117B. When squelch relay K101 energizes, ground is applied to the junction of R205-R206, and V117B operates with normal cathode bias. The output is

coupled to the audio output stage.

(2) Audio output amplifier V118 is a single-ended class A amplifier. It drives output transformer T102, which provides impedance matching to various loads. Winding 3-4-5 provides an output through matching T networks to a balanced 600-ohm load. Winding 6-7-8-9 provides outputs to match 4-, 8-, or 16-ohm speakers. Any speaker returned to ground through the 0 ohm terminal of E101 will be automatically disconnected when a headset is connected at PHONES jack J103.

g. S METER.

(1) The S meter circuit receives either the avc voltage or the audio output. The audio output voltage is attenuated by VU METER ADJ R210 and is rectified by CR107 and filtered by R211 and C268. The resulting negative dc voltage is applied to the S meter circuit through RF/AF switch S110 when the switch is depressed. The avc buss voltage is attenuated by RF ADJ R196 and is applied to the S meter circuit when switch S110 is released.

(2) S Meter M101 is connected to a bridge circuit, which has three fixed-resistance legs and one leg in which meter amplifier V117A serves as a variable resistance. With zero on the grid of V117A, METER ZERO ADJ R200 is adjusted so that the current through V117A exactly balances the bridge. As the grid voltage becomes increasingly negative with increased rf input or increased audio output, the plate voltage of V117A increases and the bridge becomes increasingly unbalanced. The meter reading is directly proportional to this unbalance.

h. CALIBRATION. - Marker oscillator V102 consists of an electron-coupled crystal-controlled Colpitts circuit. The circuit is energized only when CAL switch S103 is in the ON position. The output of V102 is applied through the rf amplifier which is tuned to select the desired harmonic of 100 kc, the fundamental frequency set by crystal Y101.

i. POWER SUPPLY. - The power supply is a standard full-wave bridge circuit with a capacitor-input filter. R101 protects the bridge circuit from the surge of current that charges capacitor C121 when power is turned on. The +250-volt output is dropped by R103 and regulated by V101 to produce the +105-volt output.

SECTION 5 MAINTENANCE

5-1. PREVENTIVE MAINTENANCE.

Preventive maintenance consists of routine procedures designed to detect possible sources of trouble in the GPR-92A before complete failure can occur. These procedures include visual inspection and cleaning. Periodic testing of individual components is not preventive maintenance, and may do more harm than good.

WARNING

Dangerously high voltages exist in the receiver. Always make sure that the unit is disconnected from all auxiliary equipment before servicing. In addition, the +250 V line should be discharged with a grounding stick before servicing.

Cleaning is necessary, because dust may accumulate on certain components and not only reduce the efficiency of the receiver, but also increase component wear. Either a vacuum cleaner or compressed air hose is the quickest and most effective method of cleaning the unit. Visually checking the unit when it is opened for cleaning can prevent downtime due to component failure. Often a deteriorating component will look bad before it actually affects the operation of the unit. Some indications of trouble are: discolored components, leaking transformers and capacitors, dirty or pitted switch and relay contacts, warped printed circuit boards, and damaged wiring. Any components found in this condition should be replaced. In addition all hardware should be checked for tightness.

5-2. CORRECTIVE MAINTENANCE.

Corrective maintenance consists of procedures designed to correct problems that have resulted in the failure of the receiver to operate properly. Sometimes, corrective maintenance will consist only of the replacement of a defective component. Generally, however, it will include trouble shooting, repair, and alignment. These three phases of corrective maintenance are discussed individually in the following paragraphs.

a. TROUBLESHOOTING.

(1) GENERAL TROUBLESHOOTING NOTES. - Troubleshooting information contained in this manual is intended only to indicate a logical approach to locating sources of trouble in the receiver. Troubleshooting data is provided to permit pinpointing a faulty component. Generally, an operator can provide sufficient information about the symptoms of trouble to reduce troubleshooting time. If no operator's information is available, the technician

should perform the operator's checks given in paragraph 3-4 to obtain the symptoms. The block diagram of the receiver (figure 4-1) shows that the operator's controls select the circuits required for a particular type of signal reception. These controls can also be used as an aid in troubleshooting. Four examples of troubleshooting with these controls are given below.

(a) MODE TEST. - In this test, the operation of the receiver is checked in each position of the MODE switch. If the receiver operates properly in AM, but not in CW and SSB, the trouble is probably in one of the BFO stages or the product detector. If the receiver does not operate properly in AM, but does in CW and SSB, the trouble is probably in either the AM detector or noise limiter. If the receiver does not operate properly in any mode, the audio stages, rf stages, or oscillator are bad. Additional tests are required to further isolate the trouble.

NOTE

If the receiver is totally inoperative, check the power supply before performing other checks.

(b) BAND TEST. - In this test, the operation of the receiver is checked on each of the tuning bands. If the receiver operates normally on the three lowest bands, but not on the three highest, the trouble is probably in the 3.5 mc i-f oscillator stages or the first mixer. If the receiver operates normally on all but one band, the trouble is in the tuning section for that band. If the receiver does not operate properly on any band, additional tests are required.

(c) INT/EXT TEST. - This test should be used only when the receiver will not operate in EXT. When this is the case, set the EXT/INT switch at INT. If the receiver operates properly, the trouble is either external or in one of the three isolation amplifiers. If the receiver does not operate properly, additional tests are required.

(d) S METER TEST. - In this test, the CAL switch is in the up (ON) position, and the reading of the S meter is observed. If the S meter reading is normal (paragraph 3-4), the trouble is between the fourth i-f amplifier and the audio output. If the S meter reading is not normal, the trouble is between marker oscillator and the avc detector.

It is obvious that any one of these tests cannot provide as much information as all four can provide. With the knowledge from the tests, the standard procedures of signal tracing or signal injection,

tube checking, and voltage and resistance measurements can be used to locate the faulty component.

(2) VOLTAGE AND RESISTANCE MEASUREMENTS.

Table 5-1 gives voltage readings and resistance readings for all of the tube stages in the receiver. Voltage readings were taken with a Hewlett Packard Vacuum Tube Voltmeter Model 410B. Resistance measurements were taken with a Simpson Multimeter Model 260. All of the readings were taken with respect to ground. The operator's controls were set to the following positions when the measurements were made.

(a) VOLTAGE MEASUREMENTS.

<u>CONTROL</u>	<u>SETTING</u>
SEND/REC	REC
IF SELECTIVITY	15 KC
LIMITER/OFF	OFF
EXT/INT	INT
SQUELCH	Full cw
RANGE SELECTOR	.54-1.4
MANUAL/AVC	MANUAL
MODE	AM

(b) RESISTANCE MEASUREMENTS.

<u>CONTROL</u>	<u>SETTING</u>
RF GAIN	OFF (removes power)
AUDIO GAIN	Full ccw

b. REPAIR. - In most cases, the repair of the GPR-92A will consist of the replacement of an electron tube or a simple electrical component; in these cases, no special instruction is required. (See figures 5-1 and 5-2.) However, the following hints are provided to ensure that the repairs are completed properly.

- (1) Always replace a defective component with its exact duplicate.
- (2) Always place a new component in the same position occupied by the one it replaces. In general, never change the existing chassis layout, whether it is wiring or component placement.
- (3) Never use a soldering iron with a rating of more than 100 watts. Use a pair of long nose pliers as a heat sink to protect components while soldering.
- (4) Be extremely careful when replacing components on printed circuit boards. Excessive heat applied to a board will cause the printed wiring to lift off.
- (5) Always double check any solder joints made. Cold or loose solder connections can cause trouble at a later time.

(6) Be sure to replace all shielding plates when reassembling the GPR-92A. Occasionally, replacement procedures and some of the electrical-part replacements are not obvious. These are provided on the following pages.

(1) REPLACEMENT OF FL102.

- (a) Unsolder the wires from TP37 through TP39 and from TP46 at bottom of assembly.
- (b) Remove two screws that hold cover to assembly; remove cover.
- (c) Set IF SELECTIVITY switch to 15 KC.
- (d) Loosen the four setscrews in coupling between assembly and shaft to IF SELECTIVITY control. Slide coupling towards front panel to remove it from assembly.
- (e) Remove the two screws that hold assembly to chassis. Remove assembly.
- (f) Mount new assembly on chassis. Be sure that switch shaft faces front panel.
- (g) Set switch fully counterclockwise.
- (h) Slide coupling over switch shaft and tighten the four setscrews.
- (i) Replace assembly cover.
- (j) Connect the four wires at bottom of assembly in following manner:

- TP37 - Red wire
- TP38 - Blue wire
- TP39 - Black wire
- TP46 - Green wire

(2) REPLACEMENT OF COMPONENTS IN Z101.

- (a) Remove V117.
- (b) Unsolder the three wires from rear of Z101.
- (c) Loosen the two setscrews that secure shaft of BFO PITCH control to tuning slug of Z101.
- (d) Remove the nuts from the two shafts on either side of BFO PITCH control shaft.
- (e) Remove Z101 from receiver.
- (f) Remove cover of Z101 (it is held in place by two screws) and replace the defective component. Replace cover.
- (g) Reinstall Z101 by reversing procedures of steps (c) and (d).

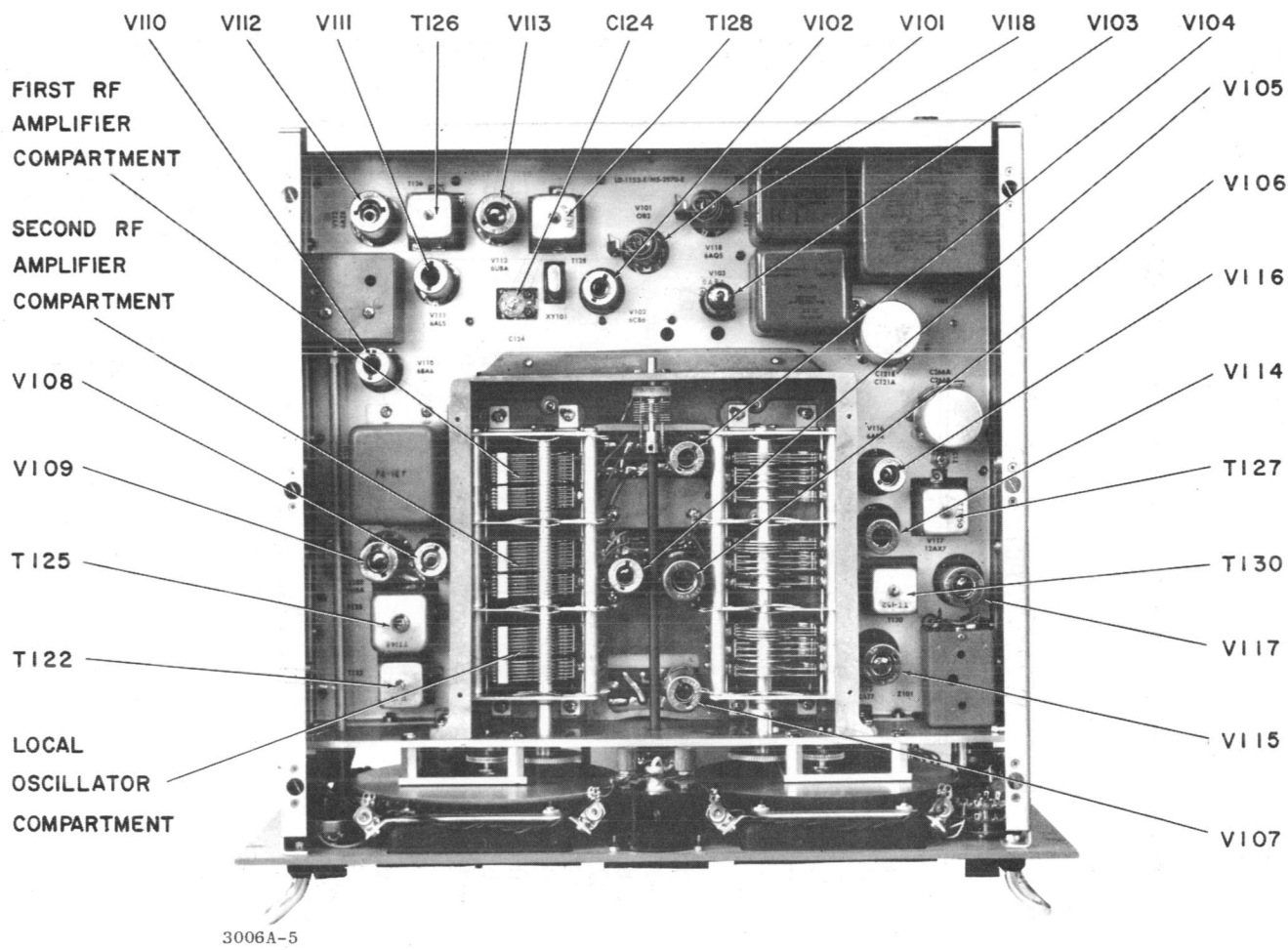

Figure 5-1. GPR-92A, Top View with Cover Removed

662.18-5

TABLE 5-1. VOLTAGE AND RESISTANCE MEASUREMENTS

TUBE	V or R	PIN								
		1	2	3	4	5	6	7	8	9
V101	V	105	0	-	0	105	-	0	-	-
V102	R	23K	0	-	0	23K	-	0	-	-
(Note 1)	V	-26	0	6.3vac	0	0	49	0	-	-
V103	R	1 Mega	0	0	0	800K	100	0	-	-
(Note 12)	V	160V	0	6.3vac	0	0	0	1.5V	-	-
V104	R	34K	0	0	0	100K	240	0	-	-
V105	V	0	1.2	6.3vac	0	260	1.2	0	-	-
(Note 2)	R	120K	100	0	0	23K	100	0	-	-
V106	V	0	0	6.3vac	0	90	53	0	-	-
V107	R	47	0	0	0	23K	42K	0	-	-
(Note 3)	V	100	-6	1.5	0	6.3vac	0	0	-	270
V108	R	23K	27K	100	0	0	0	300K	0	23K
(Note 3)	V	-12	110	6.3vac	0	110	110	0	-	-
V109	R	39K	23K	0	0	23K	23K	2	-	-
(Note 4)	V	0	0	0	6.3vac	110	110	1.3	-	-
V110	R	60	0	0	0	23K	23K	220	-	.66
(Note 5)	V	-1.3	0	110	0	0	220	3.2	0	70K
V111	R	INF	1 Mega	22K	0	0	45K	1.2K	2	-
(Note 4)	V	105	0	110	0	0	215	3.8	0	-2.5
V112	R	23K	1 Mega	22K	0	0	45K	1.2K	2	70K
(Note 5)	V	0	0	6.3vac	0	245	105	5.0	-	-
V113	R	250K	0	0	0	23K	70K	5.6K	-	-
(Note 5)	V	260	260	0	6.3vac	260	-	0	-	-
V114	R	23K	23K	0	0	INF	-	INF	-	-
(Note 5)	V	260	260	0	6.3vac	260	-	0	-	-
V115	R	23K	23K	0	0	INF	-	INF	-	-
(Note 7)	V	260	105	.74	6.3vac	INF	-	INF	-	-
(Note 7)	R	34K	34K	120	0	0	0	110	260	110
(Note 7)	V	0	0	180	0	0	250K	21K	31K	Note 6
(Note 7)	R	85K	16	31K	0	6.3vac	190	2.7	5.8	0
(Note 7)	V	100K	0	6.3vac	0	220	26K	180	2.7K	85K
(Note 7)	R	.110	-1.3	1.5	0	26K	110	2.8	-	-
(Note 7)	V	23K	175K	1500	0	0	60K	5.2	-	-
(Note 7)	R						100	0	1.5	-
(Note 7)	R						140K	47K	1.2K	-

TUBE	V or R	PIN								
		1	2	3	4	5	6	7	8	9
V116 (Note 8)	V	94	0	6.3vac	0	-	-1	.6	-	-
V117	R	30K	-	0	0	-	10K	330	-	-
	V	260	0	1.3	6.3vac	6.3vac	240	0	24	0
	R	22K	Note 9	Note 10	0	0	170K	Note 11	24K	0
V118	V	0	12	6.3vac	0	250	260	0	-	-
	R	220K	270	0	0	22K	29K	220K	-	-

Notes:

1. Set CAL switch to the up (ON) position.
2. Set EXT/INT switch at EXT to check these readings.
3. Set RANGE SELECTOR switch at 5.6-9.5 and EXT/INT switch to EXT to check these readings.
4. Set RANGE SELECTOR switch at 5.6-9.5 to check these readings.
5. Set LIMITER/OFF switch at LIMITER to check these readings.
6. This reading varies between 200 K and 300 K depending upon setting of SQUELCH control.
7. Set MODE switch at CW to check these readings.
8. Set MODE switch at CW and EXT/INT switch to EXT to check these readings.
9. This reading is approximately 55K with S110 depressed (depends on R210) and approximately 450K with S110 released (depends on R196).
10. This reading varies between 100 ohms and 600 ohms depending upon setting of METER ZERO ADJ R200.
11. This reading varies between 3 ohms and 500 K depending upon setting of AUDIO GAIN control.
12. These readings taken with RF GAIN control set fully clockwise; power cable disconnected.

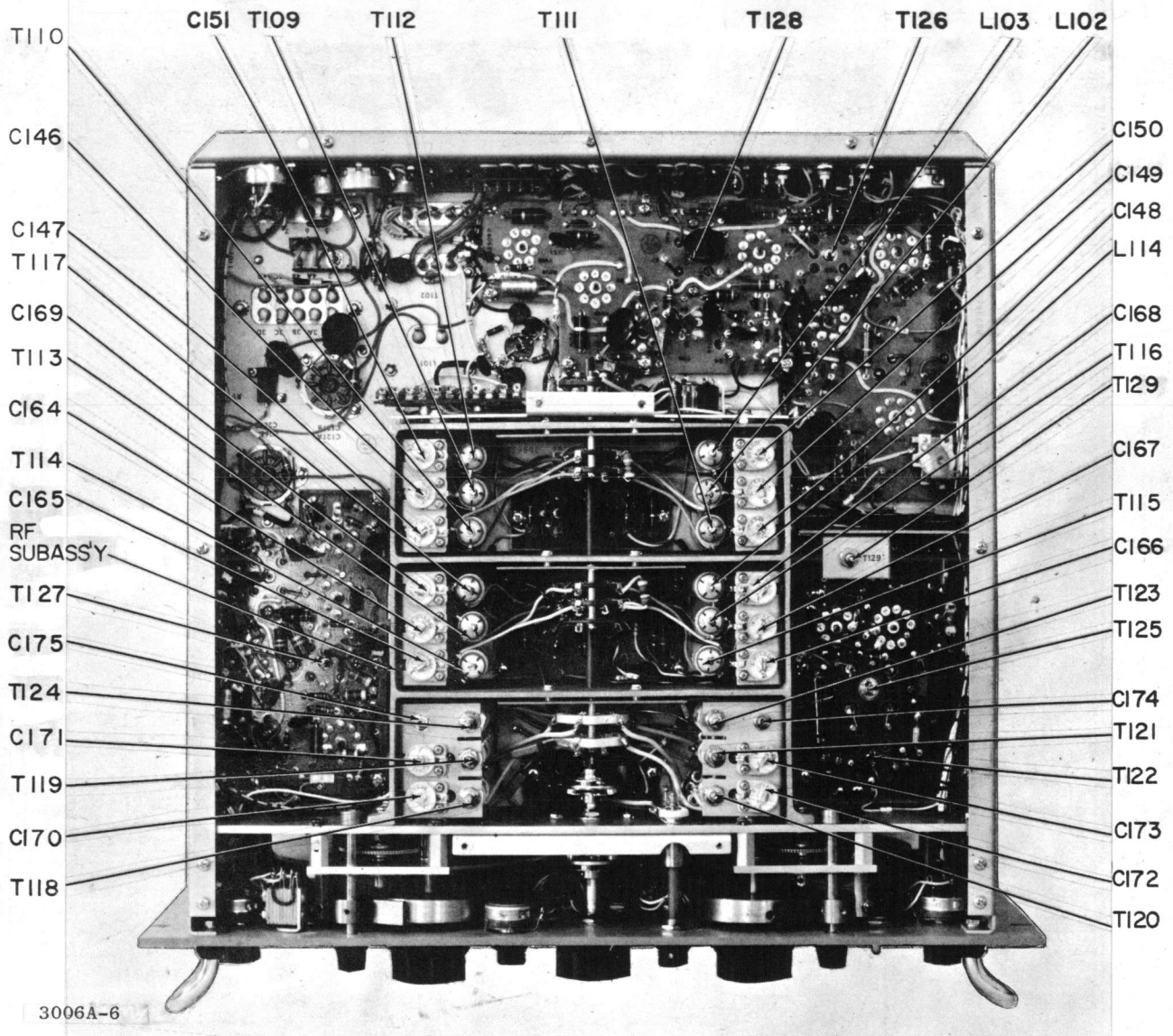

Figure 5-2. GPR-92A, Bottom View with Cover Removed

(h) Reconnect the wires to bottom of Z101 as follows:

Terminal 1	-	Red Wire
Terminal 2	-	Green Wire
Terminal 3	-	Blue Wire

(i) Reinstall V117.

(j) Align Z101 according to paragraph c(12).

(3) REPLACEMENT OF AN RF SUBASSEMBLY COMPONENT.

(a) Loosen the two setscrews on flexible coupling between shaft of S102 and shaft of detent assembly that holds shaft of S102.

(b) Slide shaft of S102 as far out of unit as required to gain access to particular printed circuit board or wafer. There is a hole in the rear panel to allow removal of shaft.

NOTE

Do not allow the center portion of any switch wafer to change position with respect to the shaft.

(c) Remove the four screws that hold particular subassembly into its compartment. Two of these screw into compartment dividers, and one screws into each end of compartment.

(d) Unsolder any wires that may prevent removal of subassembly. Be sure to record their connection points so that they can be properly reconnected.

(e) Remove subassembly, and replace component.

NOTE

If one of the wafers of S102 is to be changed, make a sketch showing the wiring and the position of the rotating contact before beginning.

(f) Replace subassembly.

(g) Slide shaft of S102 into position.

(h) Tighten the setscrews on flexible coupling between switch shaft and shaft of detent assembly that holds switch shaft.

(4) REPLACEMENT OF COMPONENTS ON PRINTED CIRCUIT BOARDS.

(a) Unsolder all wires that inhibit removal of board. Record their connection points.

(b) Remove the screws that hold board to chassis.

(c) Carefully lift board away from chassis.

(d) Replace component.

(e) Attach board to chassis.

(f) Reconnect any wires that were unsoldered in step (a).

(5) REPLACEMENT OF A DIAL LIGHT BULB.

(a) Remove the screw that secures bulb holder to rear of dial assembly.

(b) Remove holder and replace bulb.

(c) Secure bulb holder back in position.

(6) REPLACEMENT OF RANGE SELECTOR DETENT ASSEMBLY.

(a) Put a pencil mark on shaft of S102 and on chassis so that the exact position of switch is defined. At same time, note exact position of RANGE SELECTOR knob.

(b) Loosen the two setscrews on flexible coupling between shaft of detent assembly and shaft of RANGE SELECTOR knob that secure flexible coupling to knob shaft.

(c) Unthread the nut that secures knob shaft to rear of front panel. Remove RANGE SELECTOR knob.

(d) Loosen the two setscrews in flexible coupling between shaft of detent assembly and switch shaft that secures flexible coupling to detent shaft.

(e) Remove the two screws that secure detent assembly to gear plate. Remove detent assembly.

(f) Remove flexible coupling from old detent assembly and attach it to new one.

(g) Attach new detent assembly to unit by reversing procedures of steps (b) through (e).

(h) Make sure that pencil marks made in step (a) line up, and that knob position is as was noted. Readjust if necessary by means of the flexible couplings.

(7) FRONT PANEL REMOVAL. The front panel must be removed any time it is necessary to replace gears, couplings, or clutches in the tuning or bandspread systems.

(a) Make written note of all operator's control settings.

(b) Remove all knobs from front panel. All of these are held on by setscrews.

(c) Remove all nuts and retaining rings that secure the many shafts to front panel.

(d) Remove bulb-holding brackets from rear of both the TUNING and BAND SPREAD dial assemblies.

(e) Remove the four bolts at rear of panel that hold the two handles in place.

(f) Remove the two Phillips head screws that fasten front panel to receiver chassis. The front panel can now be removed.

The front panel is reassembled to the receiver by reversing the procedures of steps (b) through (f). After step (b) is performed, the operator's control should be in the positions noted in step (a). If not, the knob position relative to its associated shaft must be corrected.

(8) REPLACEMENT OF MECHANICAL TUNING AND BANDSPREAD SYSTEM COMPONENTS. This paragraph provides general hints so that a technician using figure 5-3 as a guide will be able to replace any broken or worn mechanical components.

The figure illustrates the relative positioning of the mechanical components, behind the front panel. Note that all of these components must be removed toward the front rather than the rear of the receiver. Most of the components are fastened to shafts with setscrews, and slip off easily when the setscrews are loosened. One valuable aid in simplifying the work is using pencil marks to note the relative positions of meshing gears, gears to shafts, etc. If these items are marked prior to removal, realignment should not be necessary.

NOTE

When either the bandspread or tuning capacitor is to be changed, set the capacitor fully meshed and note the dial reading before removing the capacitor. If the new capacitor is installed in the fully meshed position and the dial is positioned to give the same reading, the alignment should be correct. To check the alignment, perform the procedure in paragraph 5-2c that pertains to the capacitor replaced.

c. ALIGNMENT.

(1) WHEN ALIGNMENT IS REQUIRED. - The receiver should be aligned whenever a general decline in its performance is observed. Alignment is also required when a component in an adjustable circuit is replaced. In general, alignment should be checked whenever repairs are made.

(2) TEST EQUIPMENT REQUIRED FOR ALIGNMENT. - The equipment listed below (or equivalent equipment) is required for alignment. In addition, the tools listed in table 1-2 and standard non-metal-

lic tools are required.

(a) AC Vacuum Tube Voltmeter, Ballantine Model 314.

(b) RF Generator, Measurements Model 82.

(c) 455 kc Sweep Generator. Telonic Model SM 2000 w/L1 plug-in head.

(d) Oscilloscope, Tektronix Model 545 A with Type L plug-in unit.

(e) Frequency Counter, Hewlett Packard Model 524C.

(f) Multimeter, Simpson Model 260, Series 3.

(g) Crystal Calibrator, Measurements Model 111B.

(h) Attenuator Box, Daven Model 651-72.

(i) A 455 kc Crystal.

(j) A 4-ohm speaker.

(k) A set of 600-ohm earphones.

(l) A 600-ohm, 1-watt resistor.

(m) One set of clip leads.

(n) The impedance-matching attenuator pad illustrated in figure 5-4. This must be built if none is available.

(3) PRELIMINARY OPERATOR'S CONTROL SETTINGS.

The operator's controls must be set to the following positions before any alignment procedure is started. Because of this, the individual procedures given can be performed without referring to any others for previous control settings. Deviations from the preliminary settings are given in each procedure.

<u>CONTROL</u>	<u>SETTING</u>
NOISE LIMITER	OFF
IF SELECTIVITY	15 KC
RF GAIN	FULLY CLOCKWISE
ANT TUNE	Capacitor plates unmeshed.
SQUELCH	Fully counterclockwise
SEND/REC	REC.
MANUAL/AVC	MANUAL
EXT/INT	INT
LIMITER/OFF	OFF
PHONE LEVEL	Fully counterclockwise
TUNING	Locked at 50 on the log scale

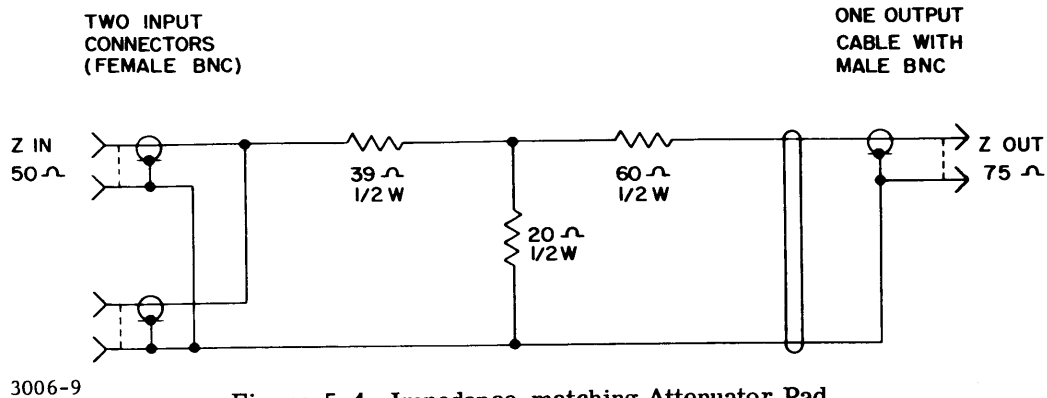

Figure 5-4. Impedance-matching Attenuator Pad

Allow the receiver to warm up for 30 minutes before starting any alignment procedures.

HFO TRIM	0
RANGE SELECTOR	.54-1.4
tone	Fully counterclockwise
BAND SPREAD	Locked at 100 on the log scale
MODE	AM
BFO PITCH	0
AUDIO GAIN	Mid-position

NOTE

Disconnect antenna before starting any alignment procedures.

(4) 455 KC I-F ALIGNMENT.

- (a) Connect rf generator between TP90 and ground.
- (b) Connect VTVM between TP99 and ground.
- (c) Set generator frequency to 455 kc, no modulation.
- (d) Adjust generator output to obtain a reading on VTVM. The VTVM scale used is unimportant.
- (e) Adjust bottom slug of T130 for maximum meter deflection.
- (f) Adjust top slug of T130 for a dip in the meter indication. This dip will be between 6 and 8 db.
- (g) Connect rf generator between the junction of R153 and C229 and ground. Do not change setting of generator controls.
- (h) Connect VTVM between TP50 and ground.
- (i) Adjust top slug of T126 for maximum meter deflection.
- (j) Adjust T127 for a dip in the meter indication. This dip will be between 6 and 8 db.
- (k) Connect rf generator between TP51 and ground.

- (l) Connect VTVM between TP65 and ground.
- (m) Adjust top slug of T128 for maximum meter deflection.
- (n) Connect a jumper between TP61 and TP62.

NOTE

TP61 and TP62 are two of the many tie points located on the receiver chassis. These tie points are numbered in the sequence that they are placed throughout the receiver. To find TP61 and TP62, look in the area of the receiver where tie points numbered in the fifties and sixties are located. The more significant tie points appear on the schematic diagram.

- (o) Connect rf generator between the junction of C192 and contact 3 of S102F (front) and ground.
 - (p) Connect VTVM between TP8 and ground.
 - (q) Adjust top slug of T122 for maximum meter deflection.
 - (r) Adjust bottom slug of T122 for a dip in the meter indication. This dip will be between 6 and 8 db.
 - (s) Disconnect jumper between TP61 and TP62.
- #### (5) 3.955 MC I-F ALIGNMENT.
- (a) Connect a jumper between TP61 and TP62.
 - (b) Set RANGE SELECTOR switch to 5.6-9.5.
 - (c) Set EXT/INT switch at EXT.
 - (d) Connect VTVM between the junction of R142 and R143 and ground.
 - (e) Connect rf generator between the junction of T116 and C167 and ground.
 - (f) Set generator frequency to 3.955 mc, no modulation.
 - (g) Adjust generator output to obtain a read-

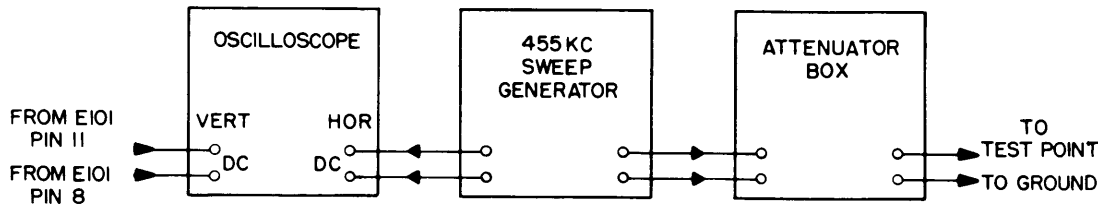

3006-10

Figure 5-5. I-F Sweep Alignment Test Setup

ing on VTVM. The VTVM scale used is unimportant.

(h) Adjust top slug of T125 for maximum meter deflection.

(i) Adjust bottom slug of T125 for maximum meter deflection.

(j) Set RANGE SELECTOR switch to .54-1.4.

(k) Set EXT/INT switch to INT.

(l) Disconnect jumper between TP61 and TP62.

(6) IFO ALIGNMENT.

(a) Connect a jumper between TP61 and TP62.

(b) Set RANGE SELECTOR switch to 5.6-9.5.

(c) Set EXT/INT switch to EXT.

(d) Connect rf generator to J106.

(e) Connect VTVM between the junction of R142 and R143 and ground.

(f) Set generator frequency to 3.500 mc, no modulation.

(g) Adjust generator output to obtain a reading on VTVM. The VTVM scale used is unimportant.

(h) Adjust T129 for maximum meter deflection.

(i) Set RANGE SELECTOR switch to .54-1.4.

(j) Set EXT/INT switch to INT.

(k) Disconnect jumper between TP61 and TP62.

(7) I-F SWEEP ALIGNMENT.

(a) Connect a jumper between TP61 and TP62.

(b) Connect test setup shown in figure 5-5.

(c) Connect attenuator box between TP90 and ground.

(d) Connect 455 kc crystal between TP100 and ground. Use clip leads for this purpose.

(e) Adjust top slug of T130 for maximum amplitude of the waveform at the 455 kc marker.

(f) Adjust bottom slug of T130 for maximum flatness of the waveform. At the point of maximum flatness, a dip in the center of the curve may be present. This dip is permissible.

NOTE

The waveform must be symmetrical about the 455 kc marker. If it is not, the bottom slug of T130 must be readjusted. Its final position must represent a compromise between maximum flatness and waveform symmetry.

(g) Connect attenuator box between the junction of R153 and C229 and ground.

(h) Adjust T126 for maximum amplitude of the waveform at the 455 kc marker.

(i) Adjust T127 for maximum flatness of the waveform. At the point of maximum flatness, a dip in the center of the curve may be present. This dip is permissible.

NOTE

The waveform must be symmetrical about the 455 kc marker. If it is not, T127 must be readjusted. Its final position must represent a compromise between maximum flatness and waveform symmetry.

(j) Connect attenuator box between the junction of R147 and C221 and ground.

(k) Remove cover from FL102.

(l) Adjust T132 so that the 455 kc marker is in the center of the curve.

- (m) Put cover back on FL102.
- (n) Set IF SELECTIVITY switch to 3 KC.
- (o) Adjust T131 for maximum flatness of the waveform.
- (p) Set IF SELECTIVITY switch to 7.5 KC.
- (q) Adjust C227 so that waveform is symmetrical about 455 kc.
- (r) Repeat steps (n) and (o).
- (s) Set IF SELECTIVITY switch to 15 KC.
- (t) Connect attenuator box between the junction of C192 and contact 3 of S102F (front).
- (u) Adjust top slug of T122 for maximum amplitude of the waveform.
- (v) Adjust bottom slug of T122 for maximum flatness of the waveform. At the point of maximum flatness, a dip in the center of the curve may be present. This dip is permissible.

NOTE

The waveform must be symmetrical about the 455 kc marker. If it is not, the bottom slug of T122 must be readjusted. Its final position must represent a compromise between maximum flatness and waveform symmetry.

- (w) Disconnect 455 kc crystal.
- (x) Disconnect jumper between TP61 and TP62.

(8) RF ALIGNMENT.

NOTE

The cover that fits over the rf section of the GPR-92A must be in place during the following procedure.

- (a) Connect a jumper between TP61 and TP62.
- (b) Connect impedance-matching attenuator pad to J104.
- (c) Connect rf generator to attenuator pad.
- (d) Connect VTVM between terminal 11 of E101 and ground.
- (e) Set generator modulation frequency to 1 kc. The percentage of modulation is unimportant.
- (f) Set generator frequency to 0.60 mc.
- (g) Set TUNING dial to 0.60 mc.
- (h) Adjust T118, T113, and T109 for maximum meter deflection. This tunes the low end of the band.
- (i) Set the generator frequency to 1.30 mc.
- (j) Set TUNING dial to 1.30 mc.
- (k) Adjust C170, C164 and C146 for maximum meter deflection. This tunes the high end of the band.

(l) Repeat steps (f) through (k) for the rest of the bands using table 5-2 as a guide. Note that there are three adjustments on the low end of each band and four on the high end of each band.

- (m) Disconnect jumper between TP61 and TP62.

(9) OSCILLATOR CALIBRATION.

- (a) Connect a jumper between TP61 and TP62.
- (b) Connect crystal calibrator to J104.
- (c) Set calibrator MOD switch to OFF.
- (d) Set calibrator MEGACYCLE switch to 0.1.
- (e) Connect the 4 ohm speaker to the proper

TABLE 5-2. RF ALIGNMENT CHART

RANGE SELECTOR SWITCH SETTING	TUNING DIAL SETTING (MC)	ADJUSTMENT		
		OSC	MIX	RF
.54 - 1.4	0.60	T118	T113	T109
.54 - 1.4	1.30	C170	C165	C147
1.4 - 3.3	1.50	T119	T114	T110
1.4 - 3.3	3.20	C171	C165	C147
3.3 - 5.6	3.40	T120	T115	T111
3.3 - 5.6	5.40	C172	C166	C148
5.6 - 9.5	6.00	T121	T116	L102
5.6 - 9.5	9.00	C173	C167	C149
9.5 - 17.5	10.00	T123	L114	L103
9.5 - 17.5	17.00	C174	C168	C150
17.5 - 32.3	18.00	T124	T117	T112
17.5 - 32.3	32.00	C175	C169	C151

terminals of E101.

- (f) Set MANUAL/AVC switch to AVC.
- (g) Set MODE switch to CW.
- (h) Set TUNING dial to 0.6 mc.
- (i) Adjust T118 for a zero beat.
- (j) Set TUNING dial for 1.3 mc.
- (k) Adjust C170 for a zero beat.
- (l) Repeat steps (h) through (k) until no further adjustment is required.

(m) Repeat steps (h) through (l) for the rest of the bands using table 5-2 as a guide. Note that there is one adjustment (listed in the OSC column) on each end of the band.

NOTE

It may be necessary to set the MEGACYCLE switch to 1.0 in some cases to obtain the desired result.

- (n) Set RANGE SELECTOR switch to 1.4-3.3.

(o) Starting at the high end, tune through the entire band. Check to see that zero beats are obtained at each 100 kc marker. At no point should a zero beat occur more than 3/4 of a division away from a marker. If it does, set the TUNING dial to the 100 kc marker. Bend the plates of the smaller tuning capacitor in the oscillator section to obtain a zero beat.

NOTE

Only the plates that are partially meshed at the point of the error should be adjusted.

- (p) Set RANGE SELECTOR switch to .54-1.4.
- (q) Repeat step (o). If an error is found, bend the plates of the larger capacitor rather than the smaller one.
- (r) Set MANUAL/AVC switch to MANUAL.
- (s) Disconnect jumper between TP61 and TP62.
- (10) OSCILLATOR BAND SPREAD CALIBRATION.
 - (a) Connect a jumper between TP61 and TP62.
 - (b) Connect crystal calibrator to J104.
 - (c) Set calibrator MOD switch to OFF.
 - (d) Set calibrator MEGACYCLE switch to 1 mc.
 - (e) Connect the 4-ohm speaker to the correct terminals of E101.

- (f) Set MANUAL/AVC switch to AVC.
- (g) Set RANGE SELECTOR switch to 9.5-17.5.
- (h) Set TUNING dial to 20 M (14.5 mc).
- (i) Slowly adjust TUNING dial to obtain the zero beat nearest the setting of step (h).
- (j) Lock TUNING dial.

NOTE

When performing step (k) below, only the plates that are partially meshed at the point of error should be adjusted.

(k) Starting at the high end, tune through the entire 20 M bandspread dial. Check to see that zero beats are obtained at each 100 kc marker. At no point should a zero beat occur more than one division away from a marker. If it does, set the bandspread dial to the 100 kc marker. Bend the plates of the smallest bandspread capacitor in the oscillator section to obtain a zero beat.

- (l) Set RANGE SELECTOR switch to 17.3-32.3.

- (m) Set TUNING dial to 15 M (21.8 mc).

(n) Slowly adjust TUNING dial to obtain the zero beat nearest the setting of step (m).

- (o) Lock TUNING dial.

(p) Repeat step (k) for the 15 M band. If an error is found, bend the plates of the middle bandspread capacitor in the oscillator section to correct the error. The note preceding step (k) applies to this step also.

- (q) Set RANGE SELECTOR switch to 1.4-3.3.

- (r) Set TUNING dial to 160 M (2.0 mc).

(s) Slowly adjust TUNING dial to obtain the zero beat nearest the setting of step (r).

- (t) Lock TUNING dial.

(u) Repeat step (k) for the 160 M band. If an error is found, bend the plates of the largest capacitor in the oscillator section to correct the error. The note preceding step (k) applies to this step also.

- (v) Set BAND SPREAD dial to 100 log and lock it.

- (w) Disconnect jumper between TP61 and TP62.

(11) FINAL RF ALIGNMENT.

- (a) Connect a jumper between TP61 and TP62.

(b) Connect impedance-matching attenuator pad to J104.

- (c) Connect rf generator to attenuator pad.
 - (d) Connect VTVM between terminal 11 of E101 and ground.
 - (e) Set generator modulation frequency to 1 kc. The percentage of modulation is unimportant.
 - (f) Set generator frequency to 0.60 mc.
 - (g) Set TUNING dial to 0.60 mc.
 - (h) Adjust T113 and T109 for maximum meter deflection. This tunes the low end of the band.
 - (i) Set generator frequency to 1.30 mc.
 - (j) Set TUNING dial to 1.30 mc.
 - (k) Adjust C164 and C146 for maximum meter deflection. This tunes the high end of the band.
 - (l) Repeat steps (f) through (k) for the rest of the bands using table 5-2 as a guide. Note that there are two adjustments on the low end of each band and three on the high end of each band. Do not touch the adjustments listed in the OSC columns.
 - (m) Disconnect jumper between TP61 and TP62.
- (12) BFO ADJUSTMENT.
- (a) Connect a jumper between TP61 and TP62.
 - (b) Set MODE switch to CW.
 - (c) Set SEND/REC switch to SEND.
 - (d) Connect VTVM between the junction of pin 6 of V115 and R189 and ground.
 - (e) Connect frequency counter to AMPLIFIER OUTPUT of VTVM.
 - (f) Loosen stop on the shaft between BFO PITCH control and Z101.
 - (g) Set BFO PITCH control so that counter reads exactly 455 kc.
 - (h) Loosen setscrew that holds BFO PITCH control knob to its shaft. Be careful not to move shaft.
 - (i) Set knob indicator to zero and tighten setscrew.
 - (j) Fasten stop to shaft so that BFO PITCH control can be set to any one of the points marked on the front panel.
 - (k) Check to see that counter reads exactly 455 kc when the control is set to 0.
 - (l) Check to see that range of BFO PITCH control extends from $452 \pm .3$ kc to $458 \pm .3$ kc.

- (m) Set MODE switch to SSB and repeat steps (k) and (l).
 - (n) Repeat steps (f) through (m) until the desired results are obtained.
 - (o) Set MODE switch to AM.
 - (p) Set SEND/REC switch to REC.
 - (q) Disconnect jumper between TP61 and TP62.
- (13) 100 KC ADJUSTMENT.
- (a) Connect a jumper between TP61 and TP62.
 - (b) Connect VTVM between the junction of C123 and R105 and ground.
 - (c) Connect frequency counter to AMPLIFIER OUTPUT of VTVM.
 - (d) Set CAL switch to the up (ON) position and adjust C124 so that counter reads exactly 100 kc.
 - (e) Disconnect jumper between TP61 and TP62.
- (14) METER CALIBRATION.
- (a) Set MANUAL/AVC switch to AVC.
 - (b) Connect rf generator to J104.
 - (c) Set generator modulation frequency to 1 kc with 30% modulation.
 - (d) Set generator to 5.0 mc.
 - (e) Adjust generator output to 1 microvolt.
 - (f) Set RF ADJ R196 fully clockwise.
 - (g) Set RF GAIN control fully counterclockwise.
 - (h) Set AUDIO GAIN control fully counterclockwise.
 - (i) Press RF/AF button, and adjust METER ZERO ADJ R200 for a zero reading on black scale of front-panel meter.
 - (j) Release RF/AF button.

NOTE

- It is normal for the meter not to read zero after step (j).
- (k) Set RF GAIN control fully clockwise.
 - (l) Tune receiver to 5.0 mc.
 - (m) Adjust IF GAIN R150 to get a slight deflection on meter.

- (n) Adjust generator output to 1000 microvolts.
- (o) Set RF ADJ R196 so that meter reads 60 db on black scale.
- (p) Adjust generator output to 100 microvolts. The meter should read 40 db \pm 10%. If not, repeat steps (d) through (o).
- (q) Adjust generator output to 30 microvolts.
- (r) Connect 600-ohm 1-watt resistor between terminals 1 and 2 of E101.
- (s) Connect multimeter across resistor.
- (t) Plug earphones into PHONES jack.
- (u) Set multimeter to 2.5 vac.
- (v) Hold RF/AF button in.

(w) Set AUDIO GAIN control so that multimeter reads 0 db.

(x) Set VU METER ADJ R210 so that front panel meter reads 0 dbm on red scale.

(y) Adjust AUDIO GAIN so that multimeter reads +5 db. The front panel meter should read +5 dbm on red scale. If not, repeat steps (w) and (x).

(z) Adjust AUDIO GAIN so that multimeter reads -5 db. The front panel meter should read -5 dbm on red scale. If not, repeat steps (w) and (x).

The alignment of the receiver is completed. Now perform the operator's checks given in paragraph 3-4. Record the data obtained from the checks for future reference by operators.

SECTION 6

PARTS LIST

6-1 INTRODUCTION

The parts list presented in this section is a cross-reference list of parts identified by a reference designation and TMC part number. In most cases, parts appearing on schematic diagrams are assigned reference designations in accordance with MIL-STD-16. Wherever practicable, the reference designation is marked on the equipment, close to the part it identifies. In most cases, mechanical and electro-mechanical parts have TMC part numbers stamped on them.

To expedite delivery when ordering any part, specify the following:

- a. Generic name.

- b. Reference designation.
- c. TMC part number.
- d. Model and serial numbers of the equipment containing the part being replaced; this can be obtained from the equipment nameplate.

For replacement parts not covered by warranty (refer to warranty sheet in front of manual), address all purchase orders to:

The Technical Materiel Corporation
 Attention: Sales Department
 700 Fenimore Road
 Mamaroneck, New York

REF SYMBOL	DESCRIPTION	TMC PART NUMBER
C101	CAPACITOR, FIXED, CERAMIC DIELECTRIC: 100,000 uuf, +80% -20%; 500 WVDC.	CC100-32
C102	Same as C101.	
C103	CAPACITOR, FIXED, CERAMIC DIELECTRIC: 5,000 uuf, GMV; 500 WVDC.	CC100-15
C104	CAPACITOR, FIXED, CERAMIC DIELECTRIC: 1,000 uuf, GMV; 500 WVDC.	CC100-29
C105	CAPACITOR, FIXED, CERAMIC DIELECTRIC: 20,000 uuf, +80% -20%; 500 WVDC.	CC100-24
C106	Same as C105.	
C107	CAPACITOR, FIXED, CERAMIC DIELECTRIC: 10,000 uuf, GMV; 500 WVDC.	CC100-16

PARTS LIST (CONT)

REF SYMBOL	DESCRIPTION	TMC PART NUMBER
C108	NOT USED	
C109	Same as C105.	
C110	Same as C104.	
C111	Same as C104.	
C112	Same as C104.	
C113	Same as C104.	
C114	Same as C105.	
C115	Same as C104.	
C116	Same as C104.	
C117	CAPACITOR, FIXED, MICA DIELECTRIC: 150 uuf, $\pm 2\%$; 500 WVDC; Char. F.	CM15F151G03
C118	Same as C117.	
C119	CAPACITOR, FIXED, CERAMIC DIELECTRIC: 200,000 uuf, $+80\%$ -20% ; 50 WVDC.	CC100-33
C120	CAPACITOR, FIXED, CERAMIC DIELECTRIC: 3,000 uuf, GMV; 2,000 WVDC.	CC100-31
C121A, B	CAPACITOR, FIXED, ELECTROLYTIC: dual section; 45 uf each section; 350 WVDC; polarized; tubular case; octal plug-in type.	CE52C450P
C122	Same as C101.	
C123	CAPACITOR, FIXED, CERAMIC DIELECTRIC: 5 uuf, ± 0.25 uuf; 500 WVDC.	CC21SL050C
C124	CAPACITOR, VARIABLE, CERAMIC DIELECTRIC: 7-45 uuf; 500 WVDC; Char. C.	CV11C450
C125	Same as C107.	

PARTS LIST (CONT)

REF SYMBOL	DESCRIPTION	TMC PART NUMBER
C126	CAPACITOR, FIXED, MICA DIELECTRIC: 220 uuf, $\pm 5\%$; 500 WVDC; Char. C.	CM15C221J
C127	CAPACITOR, FIXED, MICA DIELECTRIC: 68 uuf, $\pm 5\%$; 500 WVDC; Char. E.	CM15E680J03
C128	Same as C127.	
C129	CAPACITOR, VARIABLE, AIR DIELECTRIC: 2.8-17 pf; 5 plates; extended rotor shaft	CB174
C130	Same as C123.	
C131	Same as C123.	
C132	CAPACITOR, FIXED, CERAMIC DIELECTRIC: 47 uuf, $\pm 10\%$; 500 WVDC, Part of T112.	CC21SL470K
C133	Same as C101.	
C134	Same as C107.	
C135	Same as C107.	
C136	Same as C107.	
C137	Same as C107.	
C138	CAPACITOR, FIXED, CERAMIC DIELECTRIC: 1,000 uuf, $\pm 10\%$; 500 WVDC.	CC100-9
C139	CAPACITOR, FIXED, MICA DIELECTRIC: 56 uuf, $\pm 2\%$; 500 WVDC, Char. C.	CM15C560G03
C140	Same as C139.	
C141	CAPACITOR, FIXED, MICA DIELECTRIC: 110 uuf, $\pm 2\%$; 500 WVDC, Char. F.	CM15F111G03
C142	Same as C107.	
C143	Same as C123.	

PARTS LIST (CONT)

REF SYMBOL	DESCRIPTION	TMC PART NUMBER
C144	Same as C103.	
C145	Same as C107.	
C146	CAPACITOR, VARIABLE, CERAMIC DIELECTRIC: 4.5 - 25 uuf; 500 WVDC; Char. A.	CV11A250
C147	CAPACITOR, VARIABLE, CERAMIC DIELECTRIC: 3-12 uuf; 500 WVDC; Char. A.	CV11A120
C148	Same as C146.	
C149	Same as C146.	
C150	Same as C146.	
C151	CAPACITOR, VARIABLE, AIR DIELECTRIC: 1.5-7 uuf; 500 WVDC; Char. A.	CV11A070
C152A, B, C	CAPACITOR, VARIABLE, AIR DIELECTRIC: bandspread, 3 sections; I A) 6.6-6.8 uuf, B) 7.4-12.8 uuf, C) 6.9-38.5 uuf; II A) 5.9-6.2 uuf, B) 7.3-12.8 uuf, C) 7.0-38.6 uuf; III A) 5.9-6.3 uuf, B) 7.4-12.7 uuf, C) 7.1-38.6 uuf, ±0.5 uuf.	CB131
C153A, B, C	CAPACITOR, VARIABLE, AIR DIELECTRIC: three main sections; six sub-sections; three with 11 plates; three with 15 plates; 8.5-135 uuf each 11 plate section; 10.5-189 uuf each 15 plate section.	CB130
C154	Same as C105.	
C155	Same as C107.	
C156	Same as C107.	
C157	CAPACITOR, FIXED, MICA DIELECTRIC: 1600 uuf, ±1%; 500 WVDC; Char. D. Part of T113.	CM20D162F
C158	Same as C107.	
C159	Same as C107.	

PARTS LIST (CONT)

REF SYMBOL	DESCRIPTION	TMC PART NUMBER
C160	CAPACITOR, FIXED, MICA DIELECTRIC: 180 uuf, $\pm 5\%$; 500 WVDC; Char. C. Part of T110.	CM15C181J
C161	Same as C123.	
C162	CAPACITOR, FIXED, CERAMIC DIELECTRIC: 22 uuf, $\pm 10\%$; 500 WVDC. Part of T117.	CC21SL220K
C163	Same as C107.	
C164	Same as C146.	
C165	Same as C146.	
C166	Same as C146.	
C167	Same as C146.	
C168	Same as C147.	
C169	Same as C151.	
C170	Same as C147.	
C171	Same as C147.	
C172	Same as C147.	
C173	Same as C146.	
C174	CAPACITOR, VARIABLE, GLASS DIELECTRIC: 0.7-12 uuf, $\pm 75\%$; 1,000 WVDC.	CV108-2
C175	Same as C174.	
C176	CAPACITOR, FIXED, MICA DIELECTRIC: 430 uuf, $\pm 1\%$; 500 WVDC; Char. D.	CM20D431F
C177	CAPACITOR, FIXED, MICA DIELECTRIC: 1300 uuf, $\pm 2\%$; 500 WVDC; Char. C.	CM20C132G
C178	CAPACITOR, FIXED, CERAMIC DIELECTRIC: 180 uuf, $\pm 5\%$; 500 WVDC. Part of T120.	CC35UJ181J

PARTS LIST (CONT)

REF SYMBOL	DESCRIPTION	TMC PART NUMBER
C179	CAPACITOR, FIXED, CERAMIC DIELECTRIC: 750 uuf, $\pm 5\%$; 500 WVDC. Part of T120.	CC45UJ751J
C180	Same as C179. Part of T120.	
C181	CAPACITOR, FIXED, MICA DIELECTRIC: 100 uuf, $\pm 5\%$; 500 WVDC; Char. F. Part of T121.	CM15F101J03
C182	CAPACITOR, FIXED, CERAMIC DIELECTRIC: 220 uuf, $\pm 5\%$; 500 WVDC. Part of T121.	CC45SH221J
C183	CAPACITOR, FIXED, CERAMIC DIELECTRIC: 91 uuf, $\pm 5\%$; 500 WVDC. Part of T121.	CC35CG910J
C184	CAPACITOR, FIXED, CERAMIC DIELECTRIC: 330 uuf, $\pm 5\%$; 500 WVDC. Part of T123.	CC45SH331J
C185	CAPACITOR, FIXED, CERAMIC DIELECTRIC: 100 uuf, $\pm 5\%$; 500 WVDC. Part of T123.	CC32SH101J
C186	CAPACITOR, FIXED, CERAMIC DIELECTRIC: 390 uuf, $\pm 5\%$; 500 WVDC. Part of T124.	CC45SH391J
C187	CAPACITOR, FIXED, CERAMIC DIELECTRIC: 390 uuf, $\pm 5\%$; 500 WVDC. Part of T124.	CC45TH391J
C188	CAPACITOR, FIXED, CERAMIC DIELECTRIC: 47 uuf, $\pm 5\%$; 500 WVDC.	CC21UJ470J
C189	CAPACITOR, VARIABLE, AIR DIELECTRIC: one section, 5 plates; 1.5 to 5 uuf.	CB122-1
C190	Same as C138.	
C191	Same as C103.	
C192	CAPACITOR, FIXED, MICA DIELECTRIC: 470 uuf, $\pm 5\%$; 500 WVDC; Char. C.	CM15C471J
C193	Same as C103.	
C194	NOT USED	

PARTS LIST (CONT)

REF SYMBOL	DESCRIPTION	TMC PART NUMBER
C195	Same as C107.	
C196	CAPACITOR, FIXED, MICA DIELECTRIC: 27 uuf, $\pm 5\%$; 500 WVDC; Char. C.	CM15C270J
C197	CAPACITOR, FIXED, CERAMIC DIELECTRIC: 2.2 uuf, $\pm 1\%$; 500 WVDC.	CC101-9
C198	Same as C103.	
C199	Same as C105.	
C200	Same as C103.	
C201	Same as C107.	
C202	Same as C107.	
C203	Same as C107.	
C204	Same as C138.	
C205	Same as C107.	
C206	Same as C103.	
C207	Same as C103.	
C208	CAPACITOR, FIXED, ELECTROLYTIC: 8 uf; 350 WVDC; with clear vinyl plastic sleeve; hermetically sealed aluminum case without mounting strap.	CE116-3VN
C209	CAPACITOR, FIXED, CERAMIC DIELECTRIC: 3 uuf, ± 0.25 uuf; 500 WVDC; Char. SL.	CC21SL030C
C210	CAPACITOR, FIXED, MICA DIELECTRIC: 820 uuf, $\pm 1\%$; 500 WVDC; Char. D.	CM20D821F
C211	Same as C107.	
C212	Same as C181.	
C213	Same as C103.	

PARTS LIST (CONT)

REF SYMBOL	DESCRIPTION	TMC PART NUMBER
C214	Same as C192.	
C215	Same as C103.	
C216	CAPACITOR, FIXED, MICA DIELECTRIC: 430 uuf, ±5%; 500 WVDC; Char. F.	CM15F431J03
C217	Same as C181.	
C218	Same as C103.	
C219	Same as C105.	
C220	CAPACITOR, FIXED, MICA DIELECTRIC: 270 uuf, ±5%; 500 WVDC; Char. F.	CM15F271J03
C221	CAPACITOR, FIXED, MICA DIELECTRIC: 150 uuf, ±5%; 500 WVDC; Char. C.	CM15C151J
C222	Same as C103.	
C223	Same as C107.	
C224	Same as C101.	
C225	Same as C107.	
C226	Same as C101.	
C227	Same as C103.	
C228	Same as C103.	
C229	CAPACITOR, FIXED, CERAMIC DIELECTRIC: 100 uuf, ±10%; 500 WVDC; Char. SL.	CC26SL101K
C230	Same as C103.	
C231	Same as C105.	

PARTS LIST (CONT)

REF SYMBOL	DESCRIPTION	TMC PART NUMBER
C232	Same as C104.	
C233	Same as C101.	
C234	Same as C105.	
C235	Same as C101.	
C236	Same as C101.	
C237	Same as C229.	
C238	Same as C105.	
C239	Same as C105.	
C240	Same as C229.	
C241	Same as C101.	
C242	Same as C107.	
C243	Same as C101.	
C244	Same as C107.	
C245	Same as C105.	
C246	Same as C107.	
C247	Same as C101.	
C248	Same as C132.	
C249	CAPACITOR, FIXED, MICA DIELECTRIC: 18 uuf, ±10%; 500 WVDC; Char. SL.	CC21SL180K
C250	CAPACITOR, FIXED, MICA DIELECTRIC: 68 uuf, ±5%; 500 WVDC; Char. C.	CM15C680J
C251	CAPACITOR, FIXED, MICA DIELECTRIC: 5 uuf, ±5%; 500 WVDC; Char. C.	CM15C050J

PARTS LIST (CONT)

REF SYMBOL	DESCRIPTION	TMC PART NUMBER
C252	Same as C181.	
C253	Same as C101.	
C254	Same as C250.	
C255	CAPACITOR, FIXED, METALIZED PAPER DIELECTRIC: high temperature; .47 uf, $\pm 10\%$; 200 WVDC.	CP106C474-2
C256	Same as C120.	
C257	Same as C104.	
C258	Same as C101.	
C259	Same as C103.	
C260	Same as C103.	
C261	Same as C220.	
C262	CAPACITOR, FIXED, ELECTROLYTIC: 25 uf, -10% $+150\%$ at 120 cps at 25° C; 50 WVDC; polarized; insulated tubular case.	CE105-25-50
C263	Same as C105.	
C264	Same as C262.	
C265	CAPACITOR, FIXED, CERAMIC DIELECTRIC: 1,500 uuf, GMV; 500 WVDC.	CC100-10
C266A, B	CAPACITOR, FIXED, ELECTROLYTIC: dual section; 20 uf each section; 350 WVDC; polarized; tubular case; octal plug-in type.	CE52C200P
C267	Same as C103.	
C268	Same as C119.	
C269	CAPACITOR, FIXED, SILVERED MICA DIELECTRIC: 270 uuf, $\pm 1\%$; 500 WVDC. Part of BFO Network, Z101.	CM200E271F

PARTS LIST (CONT)

REF SYMBOL	DESCRIPTION	TMC PART NUMBER
C270	CAPACITOR, FIXED, MICA DIELECTRIC: 150 uuf, $\pm 10\%$; 500 WVDC; Char. C. Part of BFO Network, Z101.	CM15C151K
C271	Same as C101. Part of BFO Network, Z101.	
C272	Same as C103. Part of BFO Network, Z101.	
C273	Same as C147.	
C274	Same as C126.	
C275	Same as C126.	
C276	CAPACITOR, FIXED, CERAMIC DIELECTRIC: 4.7 uuf, ± 1 uuf; 500 WVDC.	CC20RH4R7F
C277	CAPACITOR, VARIABLE, CERAMIC DIELECTRIC: 5-11 uuf; 200 WVDC; 500 min. Q at 1 Mc; low loss steatite ceramic base.	CV112-3
C278	CAPACITOR, FIXED, MICA DIELECTRIC: 51 uuf, $\pm 5\%$; 500 WVDC; Char. C.	CM15C510J03
C279	NOT USED	
C280	Same as C123.	
C281	Same as C141.	
C282	Same as C107.	
C283	CAPACITOR, FIXED, MICA DIELECTRIC: 330 uuf, $\pm 10\%$; 500 WVDC; Char. B.	CM15B331K
C284	CAPACITOR, FIXED, CERAMIC DIELECTRIC: 100,000 uuf, $+80\%$ -20% ; 100 WVDC.	CC100-28
CR101	SEMICONDUCTOR, RECTIFIER, BRIDGE: 600 volts, PRV; 420 V RMS input voltage; 1.5 amps forward current; DC output current 1.5 amps at 50°C or 1.0 amps at 100°C; peak full wave, one cycle surge current 15 amps; recurrent peak forward current 50 amps; max forward voltage drop 1 V at 100°C; molded plastic case.	DD130-600-1.5

PARTS LIST (CONT)

REF SYMBOL	DESCRIPTION	TMC PART NUMBER
CR102 thru CR104	NOT USED	
CR105	SEMICONDUCTOR DEVICE, DIODE: germanium; max. peak inverse voltage 60 volts; continuous average forward current 50 ma; max. peak forward current 150 ma; max. surge current 500 ua; max. inverse current 500 ua at 50 volts or 30 ua at 10 volts.	1N34A
CR106	SEMICONDUCTOR DEVICE, DIODE: silicon; max. peak inverse voltage 175 volts; 30 ma at 25°C and 15 ma at 150°C; two axial wire lead type terminals; hermetically sealed glass case.	1N463
CR107	Same as CR105.	
DS101	LAMP, INCANDESCENT: 6-8 volts; 0.15 amp; T-3-1/4 frosted bulb; miniature bayonet base.	BI101-47
DS102	Same as DS101.	
DS103	Same as DS101.	
DS104	Same as DS101.	
DS105	Same as DS101.	
E101	TERMINAL BOARD, BARRIER: 18 terminals; 6-32 thread x 1/4" long binder head screws; phenolic black bakelite.	TM100-18
EV101	SHIELD, ELECTRON TUBE: brass or copper, nickel plated; 2-1/4" high x 0.930" dia; tension spring, twist lock type.	TS102U03
EV102	SHIELD, ELECTRON TUBE: brass or copper, nickel plated; 1-3/4" high x 0.930" dia; tension spring, twist lock type.	TS102U02
EV103	Same as EV102.	
EV104	Same as EV102.	

PARTS LIST (CONT)

REF SYMBOL	DESCRIPTION	TMC PART NUMBER
EV105	Same as EV102.	
EV106	Same as EV101.	
EV107	Same as EV102.	
EV108	Same as EV102.	
EV109	SHIELD, ELECTRON TUBE: brass or copper, nickel plated; 1-15/16" high x 1.079" dia; tension spring, twist lock type.	TS103U02
EV110	Same as EV102.	
EV111	SHIELD, ELECTRON TUBE: brass or copper, nickel plated; 1-3/8" high x 0.930" dia; tension spring, twist lock type.	TS102U01
EV112	Same as EV109.	
EV113	Same as EV109.	
EV114	Same as EV102.	
EV115	Same as EV109.	
EV116	Same as EV102.	
EV117	Same as EV109.	
F101	FUSE, CARTRIDGE: 1-1/2 amps; time lag; 1-1/4" long x 1/4" dia; slow blow.	FU102-1.5
FL101	FILTER, BANDPASS: inductance 90-100 uh; coil resistance approx. 3.5 ohms; test frequency 790 Kc; consists of two 1,000 uuf and one 5 uuf capacitors, and one 68,000 ohm, 1/2 watt resistor.	FX167
FL102	FILTER, VARIABLE, BANDPASS: frequency 455 Kc; steel case.	FX177

PARTS LIST (CONT)

REF SYMBOL	DESCRIPTION	TMC PART NUMBER
J101	CONNECTOR, RECEPTACLE, ELECTRICAL: 2 male contacts; rated for 250 volts at 10 amps or 125 volts at 15 amps; polarized; twist lock.	JJ175
J102	NOT USED	
J103	JACK, TELEPHONE: normally closed.	JJ132
J104	CONNECTOR, RECEPTACLE, ELECTRICAL: RF; 1 round female contact, straight type; 52 ohms; series BNC to BNC.	UG625B/U
J105	Same as J104.	
J106	Same as J104.	
J107	Same as J104.	
J108	Same as J104.	
J109	Same as J104.	
K101	RELAY, ARMATURE: SPDT; 10,000 ohms, $\pm 10\%$ resistance; contact rating 1 amp at 28 VDC or 115 VAC non-inductive; max. coil power 1 watt; min. coil power .040 watt.	RL142
L1 thru L27	NOT USED	
L28	COIL, RADIO FREQUENCY: fixed; 26.4 uhy (23.8-29.0); frequency (test) 2.5 Mc; powdered iron core.	CL180
L29	COIL ASSEMBLY, RF: fixed 13.2 uhy (11.9-14.5); frequency 2.5 Mc; powdered iron core.	A1077
L30	Same as L28.	
L31	NOT USED	

PARTS LIST (CONT)

REF SYMBOL	DESCRIPTION	TMC PART NUMBER
L32	COIL ASSEMBLY, RF: fixed; 5.57 uhy (5.32-5.82); frequency 7.9 Mc; powdered iron core.	A1345
L33	Same as L32.	
L34	Same as L32.	
L101	FILTER, CHOKE: 6.5 hy min.; 170 ohms DC resistance; current rated at 170 ma DC; insulated for 2,500 volts; metal case.	TF289
L102	COIL ASSEMBLY: RF; tuned; 5 uuf, 4,700 ohms resistance; frequency, 7.9 Mc; steatite.	AC152
L103	COIL ASSEMBLY: RF; tuned; 5 uuf, 22,000 ohms resistance; frequency, 7.9 Mc; steatite.	AC153
L104	COIL ASSEMBLY: RF; fixed; 3.03 uhy (2.88-3.18); frequency 7.9 Mc; powdered iron core.	A1344
L105	COIL, RADIO FREQUENCY: fixed; 8.2 uh, $\pm 10\%$; 2.1 ohms DC resistance; molded case.	CL240-8.2
L106	CORE, TOROID: bead type; powdered iron.	CI120-1
L107	COIL, RADIO FREQUENCY: fixed; 39 uh, $\pm 10\%$; 2.0 ohms DC resistance; molded case.	CL240-39
L108	NOT USED	
L109	COIL, RADIO FREQUENCY: fixed; inductance rated at 17 uh, $\pm 20\%$; powdered iron core; 2 axial wire lead type terminals.	CL322
L110	COIL, RF: fixed; 100 uh; 2.6 ohms DC resistance; current rating 345 ma; molded case.	CL275-101
L111	COIL, RADIO FREQUENCY: fixed; $Q=85$ at 7.95 Mcs; L is smaller than 9 uhy; R=O.	CL306
L112	NOT USED	

PARTS LIST (CONT)

REF SYMBOL	DESCRIPTION	TMC PART NUMBER
L113	NOT USED	
L114	COIL ASSEMBLY: RF; tuned; 5 uuf, 15,000 ohms resistance; frequency, 7.9 Mc; steatite.	AC154
M101	METER, AUDIO LEVEL: 0-1 ma movement; 46 ohms resistance; 2-1/2" square metal case; with lampholder XDS101.	MR153
P101	CONNECTOR, PLUG, ELECTRICAL: twist lock type; polarized; two female contacts; midget size; brown bakelite; 10 amps at 250 volts; straight type. Part of power supply cable, W101.	PL176
P102	CONNECTOR, PLUG, ELECTRICAL: 3 flat male contacts; polarized; with removable ground connection; power plug. Part of power supply cable, W101.	PL218
R101	RESISTOR, FIXED, COMPOSITION: 10 ohms, $\pm 10\%$; 1 watt.	RC32GF100K
R102	RESISTOR, FIXED, COMPOSITION: 22 ohms, $\pm 10\%$; 2 watts.	RC42GF220K
R103	RESISTOR, FIXED, WIREWOUND: 3,000 ohms, $\pm 1\%$; max. continuous temperature rating 275°C; 10 watts.	RE65G3001
R104	RESISTOR, FIXED, COMPOSITION: 1,000,000 ohms, $\pm 10\%$; 1/2 watt.	RC20GF105K
R105	RESISTOR, FIXED, COMPOSITION: 820,000 ohms, $\pm 10\%$; 1/2 watt.	RC20GF824K
R106	RESISTOR, FIXED, COMPOSITION: 100,000 ohms, $\pm 10\%$; 1/2 watt.	RC20GF104K
R107	RESISTOR, FIXED, COMPOSITION: 10 ohms, $\pm 5\%$; 1/2 watt. Part of T103.	RC20GF100J
R108	Same as R106.	
R109	RESISTOR, FIXED, COMPOSITION: 220 ohms, $\pm 5\%$; 1/2 watt.	RC20GF221J

PARTS LIST (CONT)

REF SYMBOL	DESCRIPTION	TMC PART NUMBER
R110	RESISTOR, VARIABLE, COMPOSITION: 5,000 ohms, $\pm 10\%$; char. E, taper F; 1 watt, consists of switch S101, SPST normally open; 7/8" shaft length; rated at 3.0 amps at 117 VAC.	RV4NBYS502E
R111	RESISTOR, FIXED, COMPOSITION: 47 ohms, $\pm 5\%$; 1/2 watt.	RC20GF470J
R112	RESISTOR, FIXED, COMPOSITION: 4,700 ohms, $\pm 5\%$; 1/2 watt.	RC20GF472J
R113	RESISTOR, FIXED, COMPOSITION: 22,000 ohms, $\pm 5\%$; 1 watt.	RC32GF223J
R114	RESISTOR, FIXED, COMPOSITION: 15,000 ohms, $\pm 5\%$; 1 watt. Part of T112.	RC32GF153J
R115	RESISTOR, FIXED, COMPOSITION: 10,000 ohms, $\pm 5\%$; 1 watt.	RC32GF103J
R116	RESISTOR, FIXED, COMPOSITION: 120,000 ohms, $\pm 10\%$; 1/2 watt.	RC20GF124K
R117	Same as R107.	
R118	RESISTOR, FIXED, COMPOSITION: 100 ohms, $\pm 10\%$; 1/2 watt.	RC20GF101K
R119	RESISTOR, FIXED, COMPOSITION: 4,700 ohms, $\pm 10\%$; 1/2 watt.	RC20GF472K
R120	RESISTOR, FIXED, COMPOSITION: 1,000 ohms, $\pm 10\%$; 1/2 watt. Part of T116.	RC20GF102K
R121	RESISTOR, FIXED, COMPOSITION: 15,000 ohms, $\pm 5\%$; 2 watts.	RC42GF153J
R122	Same as R121. Part of T117.	
R123	RESISTOR, FIXED, COMPOSITION: 820 ohms, $\pm 10\%$; 1 watt.	RC32GF821K

PARTS LIST (CONT)

REF SYMBOL	DESCRIPTION	TMC PART NUMBER
R124	RESISTOR, FIXED, COMPOSITION: 22,000 ohms, $\pm 10\%$; 1/2 watt.	RC20GF223K
R125	Same as R111.	
R126	NOT USED	
R127	Same as R106.	
R128	RESISTOR, FIXED, COMPOSITION: 220,000 ohms, $\pm 10\%$; 1/2 watt.	RC20GF224K
R129	RESISTOR, FIXED, COMPOSITION: 2,200 ohms, $\pm 10\%$; 1/2 watt.	RC20GF222K
R130	RESISTOR, FIXED, COMPOSITION: 27,000 ohms, $\pm 10\%$; 1/2 watt.	RC20GF273K
R131	RESISTOR, FIXED, COMPOSITION: 39,000 ohms, $\pm 10\%$; 1/2 watt.	RC20GF393K
R132	RESISTOR, FIXED, COMPOSITION: 100 ohms, $\pm 5\%$; 1/2 watt.	RC20GF101J
R133	NOT USED	
R134	RESISTOR, FIXED, COMPOSITION: 680 ohms, $\pm 10\%$; 1/2 watt.	RC20GF681K
R135	Same as R134.	
R136	RESISTOR, FIXED, COMPOSITION: 470 ohms, $\pm 10\%$; 1/2 watt.	RC20GF471K
R137	RESISTOR, FIXED, COMPOSITION: 1,000 ohms, $\pm 10\%$; 1 watt.	RC32GF102K
R138	RESISTOR, FIXED, COMPOSITION: 56 ohms, $\pm 10\%$; 1/2 watt.	RC20GF560K

PARTS LIST (CONT)

REF SYMBOL	DESCRIPTION	TMC PART NUMBER
R139	Same as R109.	
R140	Same as R136.	
R141	Same as R104.	
R142	RESISTOR, FIXED, COMPOSITION: 1,200 ohms, $\pm 10\%$; 1/2 watt.	RC20GF122K
R143	Same as R111.	
R144	RESISTOR, FIXED, COMPOSITION: 68,000 ohms, $\pm 10\%$; 1/2 watt.	RC20GF683K
R145	Same as R124.	
R146	Same as R129.	
R147	RESISTOR, FIXED, COMPOSITION: 150,000 ohms, $\pm 10\%$; 1/2 watt.	RC20GF154K
R148	Same as R106.	
R149	RESISTOR, FIXED, COMPOSITION: 120 ohms, $\pm 10\%$; 1/2 watt.	RC20GF121K
R150	RESISTOR, VARIABLE, COMPOSITION: 500 ohms, $\pm 20\%$; Char. B, taper A; 2 watts.	RV4LAYS501B
R151	RESISTOR, FIXED, COMPOSITION: 47,000 ohms, $\pm 10\%$; 1/2 watt.	RC20GF473K
R152	RESISTOR, FIXED, COMPOSITION: 2,200 ohms, $\pm 10\%$; 1 watt.	RC32GF222K
R153	Same as R147.	
R154	Same as R106.	
R155	RESISTOR, FIXED, COMPOSITION: 180,000 ohms, $\pm 10\%$; 1/2 watt.	RC20GF184K
R156	Same as R149.	

PARTS LIST (CONT)

REF SYMBOL	DESCRIPTION	TMC PART NUMBER
R157	RESISTOR, VARIABLE, COMPOSITION: 5 meg. ohms, +20%; Char. B, taper A; 2 watts; consists of switch S106, normally open; 3/4" shaft length; rated at 3.0 amps at 117 VAC.	RV4NBYS505-BYY
R158	Same as R152.	
R159	RESISTOR, FIXED, COMPOSITION: 12,000 ohms, ±10%; 1/2 watt.	RC20GF123K
R160	Same as R151.	
R161	Same as R106.	
R162	RESISTOR, VARIABLE, COMPOSITION: 500,000 ohms, ±20%; Char. B, taper A; 2 watts.	RV4NAYSA504-BYY
R163	RESISTOR, FIXED, COMPOSITION: 82,000 ohms, ±10%; 1/2 watt.	RC20GF823K
R164	RESISTOR, FIXED, COMPOSITION: 82,000 ohms, ±10%; 1 watt.	RC32GF823K
R165	Same as R155.	
R166	Same as R107.	
R167	RESISTOR, FIXED, COMPOSITION: 180 ohms, ±10%; 1/2 watt.	RC20GF181K
R168	Same as R111.	
R169	Same as R119.	
R170	RESISTOR, FIXED, COMPOSITION: 4,700 ohms, ±10%; 1 watt.	RC32GF472K
R171	Same as R106.	
R172	Same as R109.	
R173	Same as R130.	

PARTS LIST (CONT)

REF SYMBOL	DESCRIPTION	TMC PART NUMBER
R174	RESISTOR, FIXED, COMPOSITION: 56,000 ohms, $\pm 10\%$; 1/2 watt.	RC20GF563K
R175	Same as R151.	
R176	RESISTOR, FIXED, COMPOSITION: 2,700 ohms, $\pm 10\%$; 1 watt.	RC32GF272K
R177	RESISTOR, FIXED, COMPOSITION: 33,000 ohms, $\pm 10\%$; 1/2 watt.	RC20GF333K
R178	RESISTOR, FIXED, COMPOSITION: 3,300 ohms, $\pm 10\%$; 1 watt.	RC32GF332K
R179	Same as R177.	
R180	RESISTOR, FIXED, COMPOSITION: 22,000 ohms, $\pm 10\%$; 2 watts.	RC42GF223K
R181	Same as R106.	
R182	Same as R151.	
R183	Same as R142.	
R184	Same as R142. Part of T114.	
R185	Same as R104.	
R186	Same as R104.	
R187	Same as R155.	
R188	Same as R155.	
R189	Same as R131.	
R190	RESISTOR, FIXED, COMPOSITION: 1,500 ohms, $\pm 10\%$; 1/2 watt.	RC20GF152K
R191	RESISTOR, FIXED, COMPOSITION: 8,200 ohms, $\pm 10\%$; 1/2 watt.	RC20GF822K

PARTS LIST (CONT)

REF SYMBOL	DESCRIPTION	TMC PART NUMBER
R192	RESISTOR, FIXED, COMPOSITION: 330 ohms, $\pm 10\%$; 1/2 watt.	RC20GF331K
R193	RESISTOR, FIXED, COMPOSITION: 10,000 ohms, $\pm 10\%$; 1/2 watt.	RC20GF103K
R194	Same as R142.	
R195	RESISTOR, FIXED, COMPOSITION: 82,000 ohms, $\pm 10\%$; 2 watts.	RC42GF823K
R196	RESISTOR, VARIABLE, COMPOSITION: 2.5 meg. ohms, $\pm 10\%$; Char. A, taper A; 2 watts.	RV4LAYS A255A
R197	Same as R193.	
R198	Same as R142.	
R199	Same as R118.	
R200	Same as R150.	
R201	Same as R162.	
R202	RESISTOR, VARIABLE, COMPOSITION: 500,000 ohms, $\pm 20\%$; Char. D, taper C; 1 watt.	RV4NAYS A504-DYY
R203	Same as R116.	
R204	Same as R129.	
R205	RESISTOR, FIXED, COMPOSITION: 220,000 ohms, $\pm 10\%$; 1 watt.	RC32GF224K
R206	Same as R124.	
R207	RESISTOR, FIXED, COMPOSITION: 5,600 ohms, $\pm 10\%$; 1/2 watt.	RC20GF562K
R208	Same as R128.	
R209	RESISTOR, FIXED, COMPOSITION: 270 ohms, $\pm 10\%$; 2 watts.	RC42GF271K

PARTS LIST (CONT)

REF SYMBOL	DESCRIPTION	TMC PART NUMBER
R210	RESISTOR, VARIABLE, COMPOSITION: 250,000 ohms, $\pm 20\%$; Char. B, taper A; 2 watts.	RV4LAYS254B
R211	RESISTOR, FIXED, COMPOSITION: 390,000 ohms, $\pm 10\%$; 1/2 watt.	RC20GF394K
R212	RESISTOR, FIXED, COMPOSITION: 270 ohms, $\pm 10\%$; 1 watt.	RC32GF271K
R213	Same as R212.	
R214	RESISTOR, FIXED, COMPOSITION: 270 ohms, $\pm 10\%$; 1/2 watt.	RC20GF271K
R215	Same as R111.	
R216	Same as R111.	
R217	Same as R214.	
R218	RESISTOR, VARIABLE, COMPOSITION: 50 ohms, $\pm 20\%$; Char. B, taper A; 2 watts.	RV4NAYSC500-BYY
R219	RESISTOR, FIXED, COMPOSITION: 22 ohms, $\pm 10\%$; 1 watt.	RC32GF220K
R220	Same as R111. Part of BFO Network, Z101.	
R221	Same as R155. Part of BFO Network, Z101.	
R222	Same as R129. Part of BFO Network, Z101.	
R223	Same as R130.	
R224	Same as R191.	
R225	Same as R149.	
R226	RESISTOR, FIXED, COMPOSITION: 39 ohms, $\pm 10\%$; 1/2 watt.	RC20GF390K
R227	Same as R107.	

PARTS LIST (CONT)

REF SYMBOL	DESCRIPTION	TMC PART NUMBER
R228	Same as R163. Part of T110.	
R229	Same as R142. Part of T110.	
R230	RESISTOR, FIXED, COMPOSITION: 68,000 ohms, $\pm 5\%$; 1/2 watt.	RC20GF683J
R231	RESISTOR, FIXED, COMPOSITION: 15,000 ohms, $\pm 10\%$; 1/2 watt.	RC20GF153K
R232	Same as R120.	
S101	Non-replaceable item. Part of R110.	
S102A	SWITCH SECTION, ROTARY: (part of A5427) shorting, rotary type; front section, 4 contacts (1 common), rear section, 4 contacts (1 common), bakelite insulation; brass terminals, silver plated.	WS100-1
S102B	SWITCH SECTION, ROTARY: (part of A5427) shorting, rotary type; front section, 3 contacts (1 common), rear section, 8 contacts (1 common), bakelite insulation; brass terminals, silver plated.	WS100-7
S102C	SWITCH SECTION, ROTARY: (part of A3334) shorting, rotary type; front section, 7 contacts (1 common), rear section, 7 contacts (1 common), bakelite insulation; brass terminals, silver plated.	WS100-2
S102D	SWITCH SECTION, ROTARY: (part of A3334) shorting, rotary type; front section, 8 contacts (1 common), rear section, 8 contacts, bakelite insulation; brass terminals, silver plated.	WS100-3
S102E	Same as S102C.	
S102F	Same as S102D.	
S102G	SWITCH SECTION, ROTARY: (part of A3335) shorting type contacts; silver plated brass terminals.	WS124-1

PARTS LIST (CONT)

REF SYMBOL	DESCRIPTION	TMC PART NUMBER
S102H	SWITCH SECTION, ROTARY: (part of A3336) shorting, rotary type; front section, 7 contacts (1 common), rear section, 7 contacts (1 common), bakelite insulation; brass terminals, silver plated.	WS100-4
S102J	SWITCH SECTION, ROTARY: (part of A3336) shorting, rotary type; front section, 8 contacts (1 common), rear section, 8 contacts, bakelite insulation; brass terminals, silver plated.	WS100-5
S103	SWITCH, TOGGLE: SPST; rated for 3 amps at 250 volts or 6 amps at 125 volts; bat type handle.	ST103-1-62
S104	Same as S103.	
S105	SWITCH, TOGGLE: DPDT; rated for 3 amps at 250 VAC/VDC or 6 amps at 125 VAC/VDC; bat type handle.	ST103-24-62
S106	Non-replaceable item. Part of R157.	
S107	Same as S103.	
S108	Same as S103.	
S109A, B	SWITCH, ROTARY: 2 sections, 3 positions, 30° angle of throw; non-shorting type contacts.	SW335
S110	SWITCH, PUSHBUTTON: SPDT; break-made contact type; power rating 250 ma; non-inductive; AC; 30 watts max. ; nickel plated brass.	SW296-1
S111A, B	SWITCH, ROTARY, CERAMIC: 2 sections, 6 positions, 30° angle of throw; shorting type contacts; silver plated brass contacts and rotor.	SW289
T101	TRANSFORMER, POWER: primary- 95-125V/190-250VAC, ±10% at 50/60 cps; single phase; secondary- A) 220 VAC at 170 amps, B) 6.3 VAC at 6 amps; hermetically sealed rectangular steel case.	TF235
T102	TRANSFORMER, AUDIO OUTPUT: primary- max. current 50 ma; max. power output 3 watts; high pot rating, 1,500 volts at 60 cps; hermetically sealed rectangular steel case.	TF234

PARTS LIST (CONT)

REF SYMBOL	DESCRIPTION	TMC PART NUMBER
T103	TRANSFORMER, ANTENNA: frequency range 2-32 Mcs; input impedance 70-300 ohms balanced-unbalanced; output impedance 300 ohms unbalanced.	TR116
T104 thru T108	NOT USED	
T109	TRANSFORMER ASSEMBLY, RADIO FREQUENCY: tuned; inductance, pri = 138 uh, sec = 195 uh; frequency pri and sec = 790 Kc.	TT179
T110	TRANSFORMER ASSEMBLY, RADIO FREQUENCY: tuned; inductance, pri = 32.5 uh, sec = 27.5 uh; frequency, pri and sec = 2.5 Mc; consists of one capacitor, C160 and two resistors, R228, R229.	TT180
T111	TRANSFORMER ASSEMBLY, RADIO FREQUENCY: tuned; inductance, pri = 190 uh, sec = 9.7 uh; frequency, pri = 790 Kc, sec = 2.5 Mc.	TT181
T112	TRANSFORMER ASSEMBLY, RADIO FREQUENCY: tuned; inductance, sec = .3 uh; frequency, sec = 25 Mc; consists of one capacitor, C141 and one resistor, R114.	TT182
T113	TRANSFORMER ASSEMBLY, RADIO FREQUENCY: tuned; inductance, pri = 280 uh, sec = 195 uh; frequency, pri and sec = 790 Kc; consists of one capacitor, C157.	TT183
T114	TRANSFORMER ASSEMBLY, RADIO FREQUENCY: tuned; inductance, pri = 94 uh; sec = 27.5 uh; frequency, pri = 790 Kc, sec = 2.5 Mc; consists of one resistor, R184.	TT184
T115	TRANSFORMER ASSEMBLY, RADIO FREQUENCY: tuned; inductance, pri = 9.0 uh, sec = 9.7 uh; frequency, pri = 7.9 Mc, sec = 2.5 Mc.	TT185
T116	TRANSFORMER ASSEMBLY, RADIO FREQUENCY: tuned; inductance, pri = 5.0 uh, sec = 3.4 uh; frequency, pri and sec = 7.9 Mc; consists of one resistor, R120.	TT186

PARTS LIST (CONT)

REF SYMBOL	DESCRIPTION	TMC PART NUMBER
T117	TRANSFORMER ASSEMBLY, RADIO FREQUENCY: tuned; inductance = .3 uh; frequency = 25 Mc; consists of one capacitor, C162 and one resistor, R122.	TT187
T118	TRANSFORMER, RADIO FREQUENCY: tuned; operating frequency .995 to 1.855 Mc; inductance, pri = 115 uh, sec = 71 uh; frequency, pri and sec = 2.52 Mc.	TT141
T119	TRANSFORMER, RADIO FREQUENCY: tuned; operating frequency 1.855 to 3.755 Mc; inductance, pri = 20.5 uh, sec = 13.5 uh; frequency, pri and sec = 2.5 Mc.	TT142
T120	TRANSFORMER, RADIO FREQUENCY: tuned; operating frequency 3.755 to 6.055 Mc; inductance, pri = 8.2 uh, sec = 5.5 uh; frequency, pri and sec = 7.9 Mc; consists of three capacitors, C178, C179, C180.	TT143
T121	TRANSFORMER, RADIO FREQUENCY: tuned; operating frequency 9.555 to 13.455 Mc; inductance, 1.2-1.5 uh; frequency, 7.9 Mc; consists of three capacitors, C181, C182, C183.	TT144
T122	TRANSFORMER, INTERMEDIATE FREQUENCY: tuned; operating frequency 455 Kc; inductance, pri and sec = 48 uh; frequency, pri and sec = 2.5 Mc; consists of two 1,500 uuf capacitors and one 33,000 ohm, 1/2 watt resistor; phenolic terminal board; aluminum case.	TT147
T123	TRANSFORMER, RADIO FREQUENCY: tuned; operating frequency 13.455 to 21.455 Mc; inductance, pri = 0.76 uh, sec = 0.50 uh; frequency = 25 Mc; consists of two capacitors, C184, C185.	TT145
T124	TRANSFORMER, RADIO FREQUENCY: tuned; operating frequency 21.255 to 36.255 Mc; inductance, .22 - 28 uh; frequency = 25 Mc; consists of two capacitors, C186, C187.	TT146
T125	TRANSFORMER, INTERMEDIATE FREQUENCY: tuned; operating frequency 3955 Kc; inductance, pri and sec = 9.5 uh; frequency, pri and sec = 7.95 Mc; consists of one 82 uuf, one 68 uuf and 1 uuf capacitors, one 82,000 ohm, 1/2 watt resistor; phenolic terminal board; aluminum case.	TT148

PARTS LIST (CONT)

REF SYMBOL	DESCRIPTION	TMC PART NUMBER
T126	TRANSFORMER, INTERMEDIATE FREQUENCY: tuned; operating frequency 455 Kc; inductance, pri and sec = 134 uh; frequency, pri and sec = 795 Kc; consists of one 510 uuf capacitor; phenolic terminal board; aluminum case.	TT149
T127	TRANSFORMER, INTERMEDIATE FREQUENCY: tuned; operating frequency 455 Kc; inductance, pri = 30 uh, sec = 134 uh; frequency, pri = 2.52 Mc, sec = 795 Kc; consists of one 510 uuf capacitor and one 68,000 ohm, 1/2 watt resistor; phenolic terminal board; aluminum case.	TT150
T128	TRANSFORMER, INTERMEDIATE FREQUENCY: tuned; operating frequency 445 Kc; inductance, pri = 240 uh; frequency, pri = 790 Kc; consists of one 360 uuf capacitor; phenolic terminal board; aluminum case.	TT151
T129	TRANSFORMER, RADIO FREQUENCY: tuned; inductance = 2.73 - 3.85 uh; frequency = 7.9 Mc.	TT188
T130	TRANSFORMER, INTERMEDIATE FREQUENCY: tuned; operating frequency 455 Kc; inductance, pri and sec = 133 uh; frequency, pri and sec = 795 Kc; consists of two 510 uuf and one 5 uuf capacitor; one 33,000 ohm, 1/2 watt resistor; phenolic terminal board; aluminum case.	TT152
T131	TRANSFORMER, INTERMEDIATE FREQUENCY: tuned; inductance, pri = 190 uh; frequency, pri = 790 Kc.	TT153
T132	TRANSFORMER, RADIO FREQUENCY: tuned; inductance, pri = 220 uh, sec = 190 uh; frequency, pri and sec = 790 Kc.	TT154
T133	TRANSFORMER, RADIO FREQUENCY: tuned; inductance, pri = 330 uh, $\pm 5\%$, sec = 250 uh, $\pm 5\%$; frequency, pri and sec = 795 Kc. Part of BFO Network, symbol Z101.	TT189
V101	TUBE, ELECTRON: voltage regulator; 7 pin miniature.	OB2
V102	TUBE, ELECTRON: sharp cutoff pentode; 7 pin miniature.	6CB6A
V103	TUBE, ELECTRON: high-mu triode; 7 pin miniature.	6AB4

PARTS LIST (CONT)

REF SYMBOL	DESCRIPTION	TMC PART NUMBER
V104	TUBE, ELECTRON: remote cutoff pentode; 7 pin miniature.	6BA6
V105	TUBE, ELECTRON: sharp cutoff pentode; 7 pin miniature.	6EW6
V106	TUBE, ELECTRON: pentagrid converter.	6BA7
V107	TUBE, ELECTRON: sharp cutoff pentode; 7 pin miniature.	6AH6
V108	TUBE, ELECTRON: sharp cutoff pentode; 7 pin miniature.	6AU6A
V109A, B	TUBE, ELECTRON: 9 pin miniature.	6U8A
V110	Same as V104.	
V111	TUBE, ELECTRON: duo diode; 7 pin miniature.	6AL5
V112A, B	TUBE, ELECTRON: medium-mu triode-semiremote cutoff pentode; 9 pin miniature.	6AZ8
V113A, B	Same as V109A, B.	
V114	Same as V104.	
V115A, B	TUBE, ELECTRON: high-mu twin-triode; 9 pin miniature.	12AT7
V116	Same as V103.	
V117A, B	TUBE, ELECTRON: high-mu twin triode; 9 pin miniature.	12AX7A
V118	TUBE, ELECTRON: beam power; 7 pin miniature.	6AQ5A
W101	CABLE ASSEMBLY, POWER, ELECTRICAL: retracted length 7", consists of two connectors, symbols P101 and P102.	CA555-3
XC121	SOCKET, ELECTRON TUBE: octal type.	TS101P01
XC266	Same as XC121.	
XDS101	Non-replaceable item. Part of M101.	

PARTS LIST (CONT)

REF SYMBOL	DESCRIPTION	TMC PART NUMBER
XDS102	LAMPHOLDER: for miniature bayonet base, T-3-1/4 bulb; right angle down turned.	TS107-2
XDS103 thru XDS105	Same as XDS102.	
XF101	FUSEHOLDER: extractor post type; accommodates cartridge fuse 1/4" dia. x 1-1/4" long; rated at 15 amps 250 V max. ; o/a length 1-3/4"; bushing mounted.	FH103
XV101	SOCKET, ELECTRON TUBE: 7 pin miniature stand-off; with center shield.	TS160-2
XV102	SOCKET, ELECTRON TUBE: 7 pin miniature stand-off; bayonet shield base, ground tab and center shield.	TS160-1
XV103	SOCKET, ELECTRON TUBE: 7 pin miniature.	TS102P01
XV104	Same as XV102.	
XV105	Same as XV102.	
XV106	SOCKET, ELECTRON TUBE: noval (9 pin) stand-off socket with bayonet shield base, ground tab and center shield.	TS161-1
XV107	Same as XV102.	
XV108	Same as XV102.	
XV109	Same as XV106.	
XV110	Same as XV102.	
XV111	Same as XV102.	
XV112	Same as XV106.	
XV113	Same as XV106.	
XV114	Same as XV102.	

PARTS LIST (CONT)

REF SYMBOL	DESCRIPTION	TMC PART NUMBER
XV115	Same as XV106.	
XV116	Same as XV102.	
XV117	Same as XV106.	
XV118	Same as XV101.	
XY101	SOCKET, CRYSTAL: 2 contacts, 0.050" dia. , spaced 0.486" center to center.	TS104-2
XY102	Same as XY101.	
XY103	SOCKET, CRYSTAL: clip type; 2 cadmium plated contacts; 2/65" x 5/32" tail slots.	TS167-1
Y101	CRYSTAL UNIT, QUARTZ: operating frequency 100,000 Kc, $\pm 0.02\%$; load capacitance 20.0 uuf. $+0.5$ uuf; operating temperature range $-40^{\circ} \begin{smallmatrix} +3 \\ -0 \end{smallmatrix} C$ to $+70^{\circ} \begin{smallmatrix} +3 \\ -0 \end{smallmatrix} C$; parallel resonance; HC-13/U holder.	CR37A/U-100.000 KC
Y102	CRYSTAL UNIT, QUARTZ: nom. frequency range 800 -20,000 Kc, $\pm 0.005\%$; operating temperature range $-55^{\circ}C$ to $+90^{\circ}C$; crystal unit max. capacitance 7.0 uuf; load capacitance 32.0 uuf, ± 0.5 uuf; parallel resonance; metal case; HC-6/U holder.	CR18A/U-3.500000 MC
Y103	CRYSTAL UNIT, QUARTZ: series resonant frequency 455.008 Kc, $\pm 0.002\%$; parallel resonant frequency 455.152 Kc; effective resistance at series resonance 2,200 ohms; load capacity 20 uuf; delta frequency 144 cps, $+10\%$; series frequency measured at $25^{\circ}C$, $\pm 5^{\circ}C$; test drive level 2 mw; maximum drift rate 50 cycles at $70^{\circ}F$; operating temperature range $35^{\circ}C$; HC-6/U holder.	CR108
Z101	NETWORK, BFO: operating frequency 455 Kc, ± 3 Kc; consists of four capacitors, C269, C270, C271, C272, three resistors, R220, R221, R222, one transformer, T133; top mounted with two 6-32 screws; $2-7/8"$ x $1.750"$ o/a dim.	NW101

SECTION 7
SCHEMATIC DIAGRAM

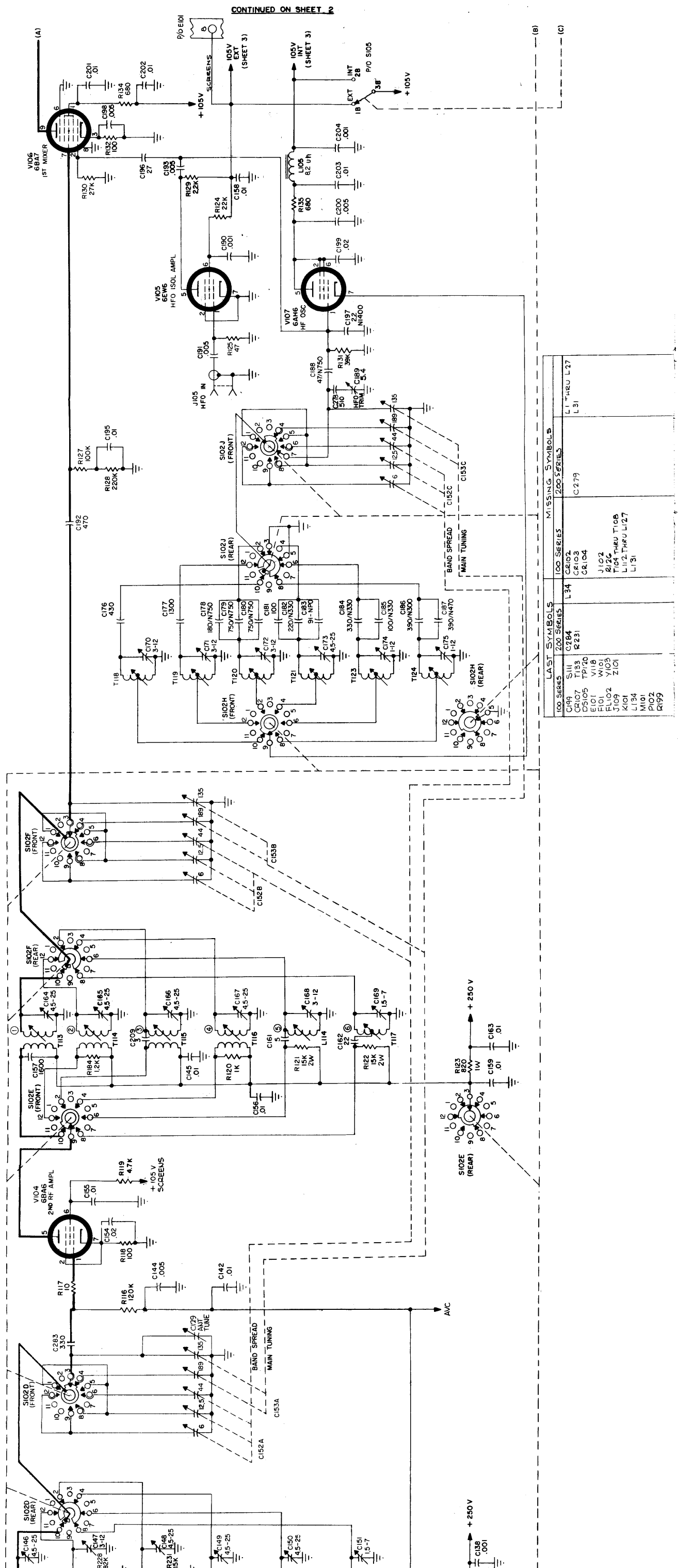

CONTINUED ON SHEET 2

LAST SYMBOLS	100 SERIES	MISSING SYMBOLS
S111	C2102	L1 THRU L27
C107	C2103	L279
T103	C2104	
E105	J102	
F101	R102	
F102	T104 THRU T106	
J109	L112 THRU L127	
K101		
L134		
M101		
P102		
R199		
S102H (FRONT)		
S102J (FRONT)		
S102J (REAR)		
S102F (FRONT)		
S102F (REAR)		
S102D (FRONT)		
S102D (REAR)		
S102E (FRONT)		
S102E (REAR)		
S102G (FRONT)		
S102G (REAR)		
S102I (FRONT)		
S102I (REAR)		
S102K (FRONT)		
S102K (REAR)		
S102L (FRONT)		
S102L (REAR)		
S102M (FRONT)		
S102M (REAR)		
S102N (FRONT)		
S102N (REAR)		
S102O (FRONT)		
S102O (REAR)		
S102P (FRONT)		
S102P (REAR)		
S102Q (FRONT)		
S102Q (REAR)		
S102R (FRONT)		
S102R (REAR)		
S102S (FRONT)		
S102S (REAR)		
S102T (FRONT)		
S102T (REAR)		
S102U (FRONT)		
S102U (REAR)		
S102V (FRONT)		
S102V (REAR)		
S102W (FRONT)		
S102W (REAR)		
S102X (FRONT)		
S102X (REAR)		
S102Y (FRONT)		
S102Y (REAR)		
S102Z (FRONT)		
S102Z (REAR)		

Figure 7-1. GPR-92A, Schematic Diagram (sheet 1 of 3)

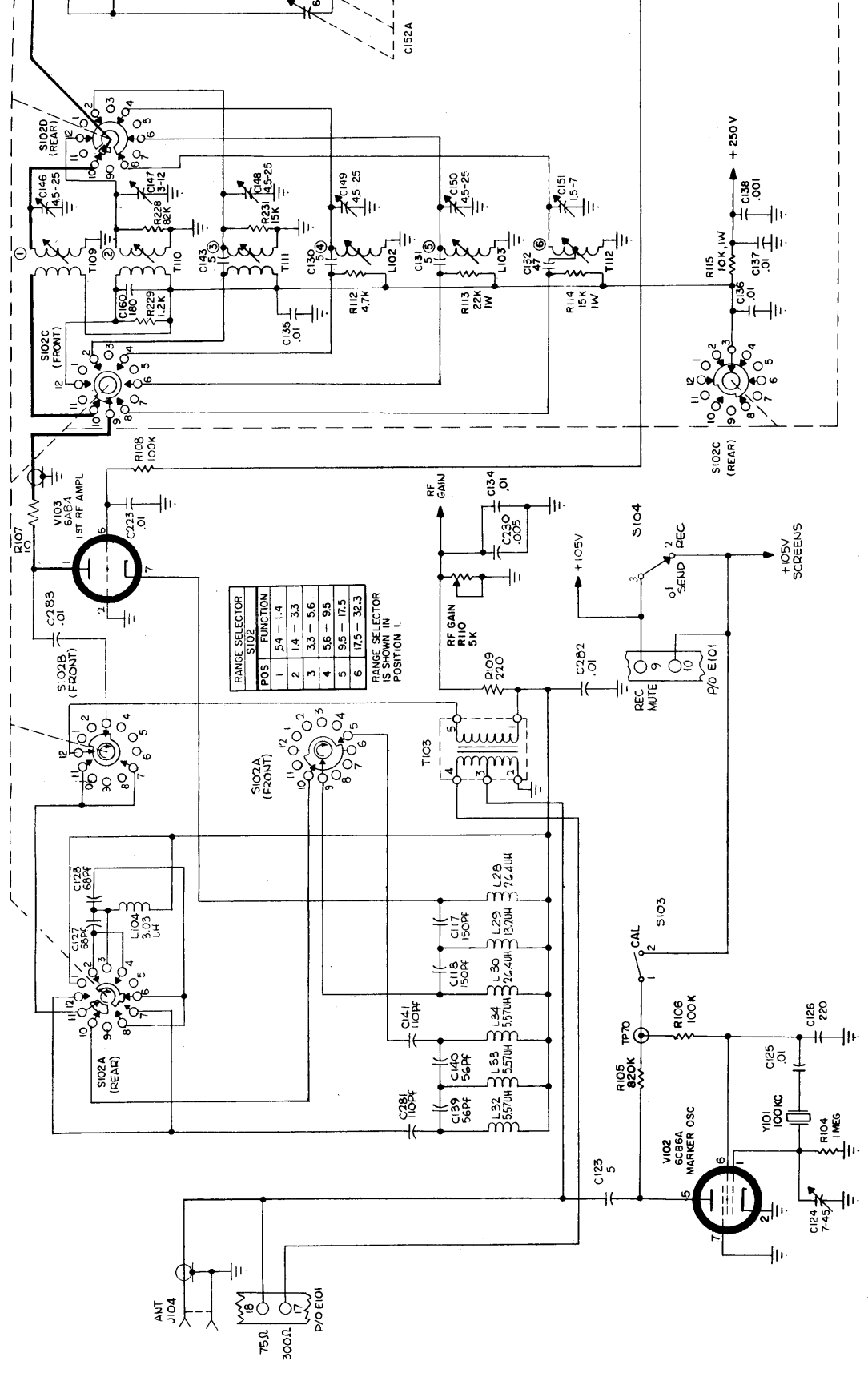

RANGE SELECTOR POS	RANGE SELECTOR FUNCTION
1	5.4 - 1.4
2	1.4 - 3.3
3	3.3 - 5.6
4	5.6 - 9.5
5	9.5 - 17.5
6	17.5 - 32.3

CK-1060

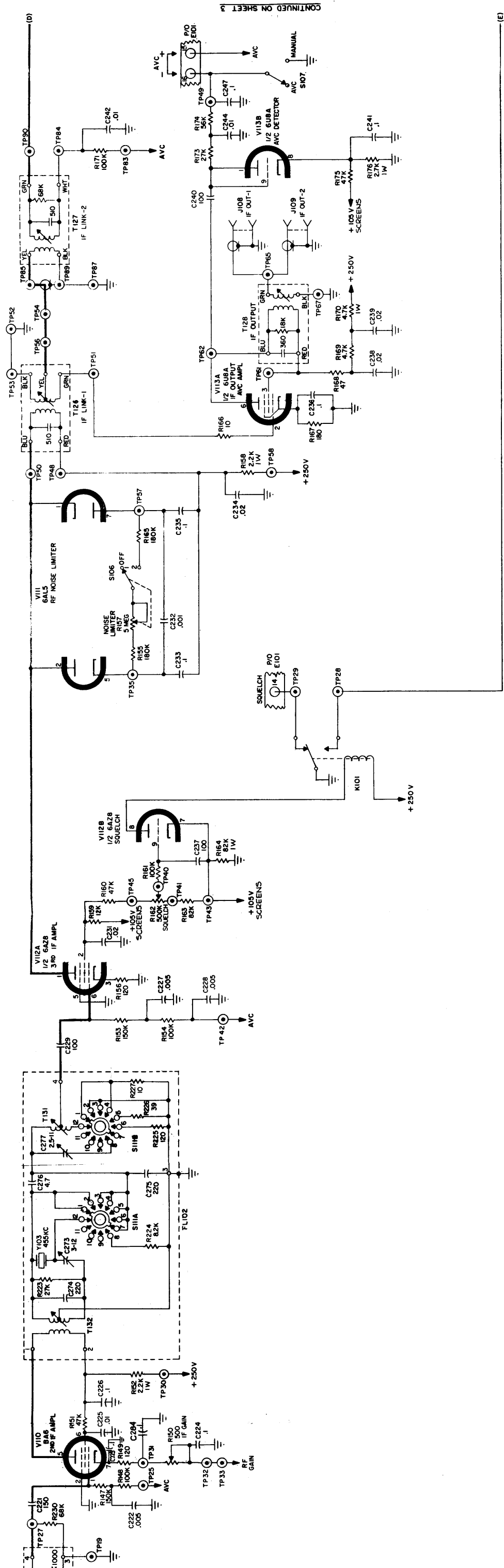

CONTINUED ON SHEET 3

Figure 7-1. GPR-92A, Schematic Diagram (sheet 2 of 3)

004663006A

7-5/7-6

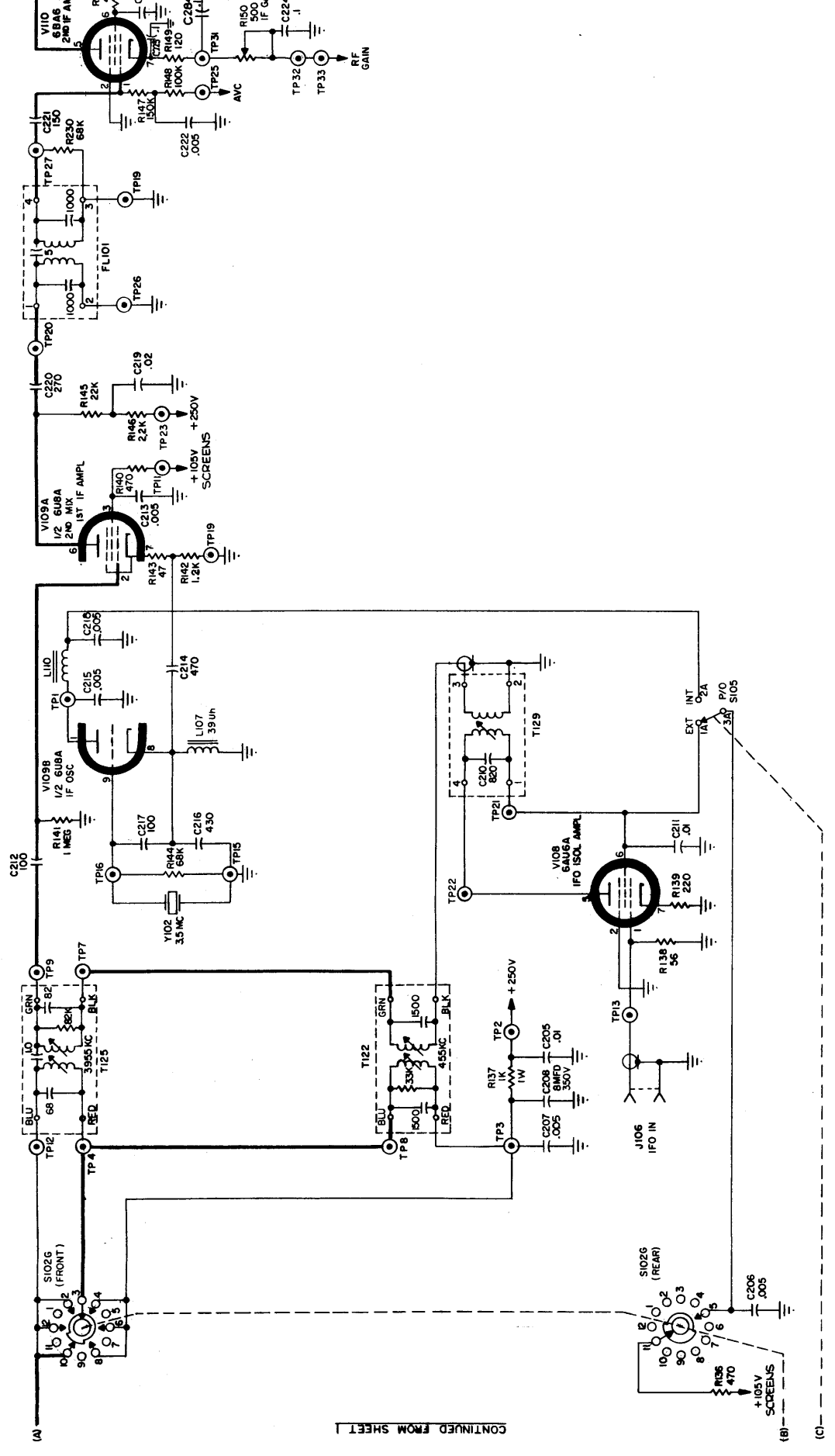

CONTINUED FROM SHEET 1

CK-1080

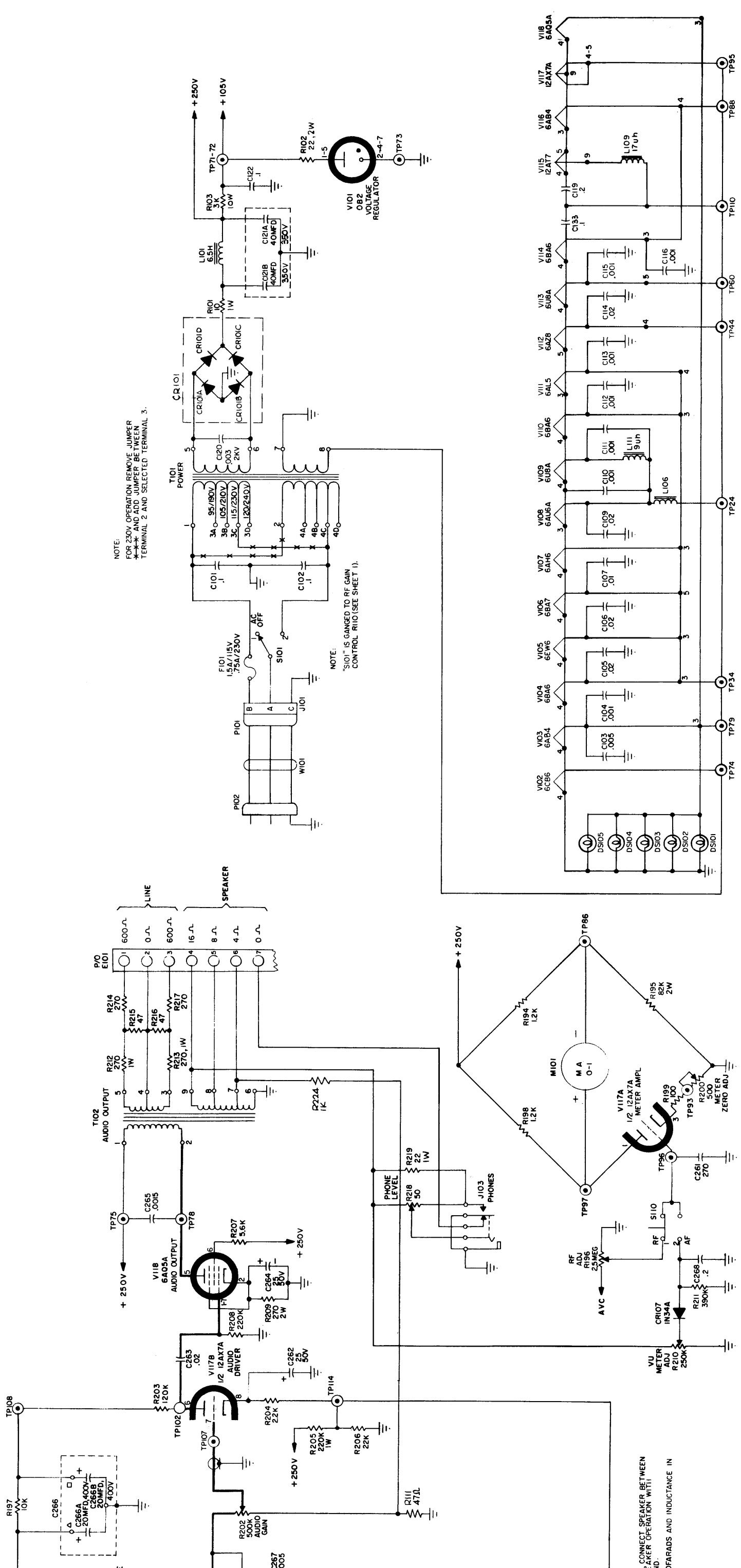

Figure 7-1. GPR-92A, Schematic Diagram (sheet 3 of 3)

