



WAØFZR
ROBERT E. STOCKHOUSE
2200 37th St. # 16
Evans, Colo. 80620

ALDA 103 Amateur Band Transceiver Operators Manual

80 meters 40 meters 20 meters
USB LSB CW

*All voltages are peak-to-peak as read
on a Lab. type 'scope., unless otherwise
Noted*

alda communications inc.
215 El Centro, Oceanside, California 92054 U.S.A.

ALDA 103 Amateur Band Transceiver

NOTE: This is an Operators Manual only. A comprehensive Maintenance Manual is available from your Dealer or from ALD INDUSTRIES, INC., 215 VIA EL CENTRO, OCEANSIDE, CA 92054.

INSTALLATION OF THE ALDA 103

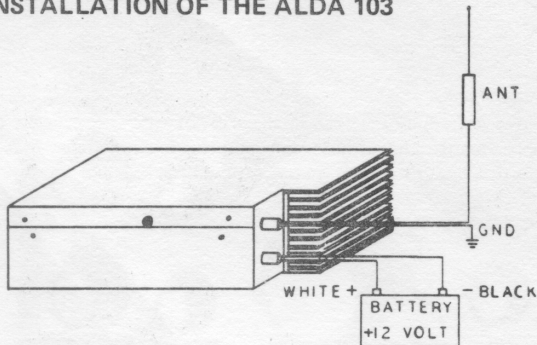

The ALDA 103 Amateur Band Transceiver is designed to operate into correctly cut and adjusted antennas with a standing wave ration of less than 1.5 to 1. While the broadband transmitter circuits will not be damaged by a higher SWR, the output power from the transmitter may be seriously reduced. New owners should realize that on 80 meters the transceiver covers 500 KHz which is a large percentage of the frequency and the antenna cannot possibly stay matched over such a wide range. Even on 20 meters, the antenna should be adjusted for the portion of the band most widely used by the operator. The performance of the transceiver will be only as good as the antenna you attach to it. The importance of a good and properly matched antenna cannot be over stressed.

In the case of Mobile installations it is imperative that good connections be made to the battery. The battery cable should go right back to the battery, not be connected to the dashboard wiring.

While every effort has been made to make the ALDA 103 impervious to ignition and alternator noise, in some installations, noise will get through. The proper place to plug a leak in a dam is at the dam. Similarly, if alternator whine is troublesome, the filter should be installed at the alternator. If ignition interference is the problem, this should be suppressed at the plugs and distributor. If the plug wires are allowed to act as an antenna there is no way the sensitive ALDA 103 can keep the ignition pulses out.

The ALDA 103 may be mounted to the vehicle with the bracket provided. The bracket may be turned over so that the radio is either supported or hung from the support. When the bracket is turned over it must also be turned end for end. The sketches show the proper way the bracket may be fitted. Note also that the transceiver may be tilted within the bracket.

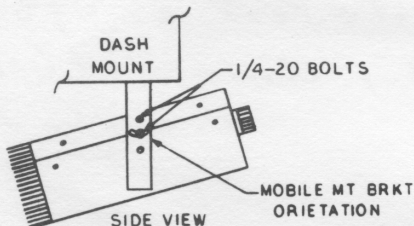

OPERATING THE ALDA 103

(Refer to the front panel diagram.)

1) Microphone jack. The microphone jack accepts a standard 3 conductor phone plug. The microphone connections are given below. The transceiver is designed to operate with a Mura type DX114 microphone. This microphone was selected as being particularly suitable for use with the ALDA 103. Other microphones may give too little output or otherwise not be suitable.

It is not necessary to withdraw the microphone plug when using CW provided the push-to-talk switch also opens the audio line when released.

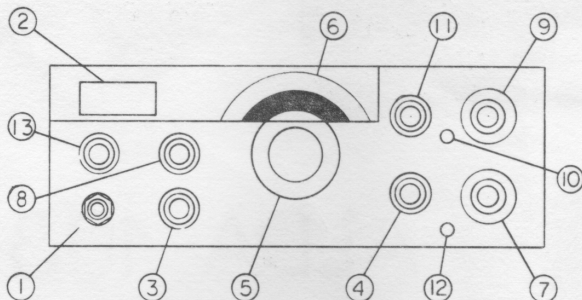
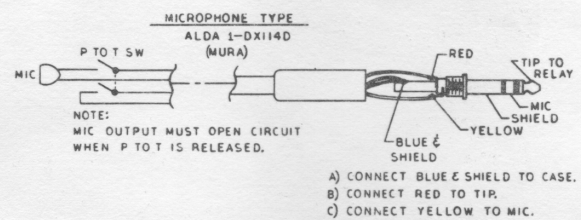

2) Meter. The meter reads the relative received signal strength and the relative transmitter power output. The word relative is used to indicate that the readings are not absolute because the readings are rendered inaccurate unless the antenna is a perfect match.

3) Receiver audio gain control. On/Off switch. To turn the receiver on turn the control clockwise. The control adjusts the receiver audio volume and, during CW transmit mode, the level of the CW sidetone.

4) Receiver RF gain control. The RF gain control has about 20 db of control. Unless there is considerable noise or very strong adjacent stations the control should be operated in the fully clockwise position.

5) Coarse and fine tuning control. The tuning control is a two speed device. To tune in a station, tune past the wanted frequency then return to the area of the wanted frequency. It will be found that the slow speed is now in effect. The coarse speed enables the operator to move from one end of the band to the other very quickly. The fine tuning gives about 25 KHz of slow search area.

BAL MIX

NB GATE

1ST IF AMP

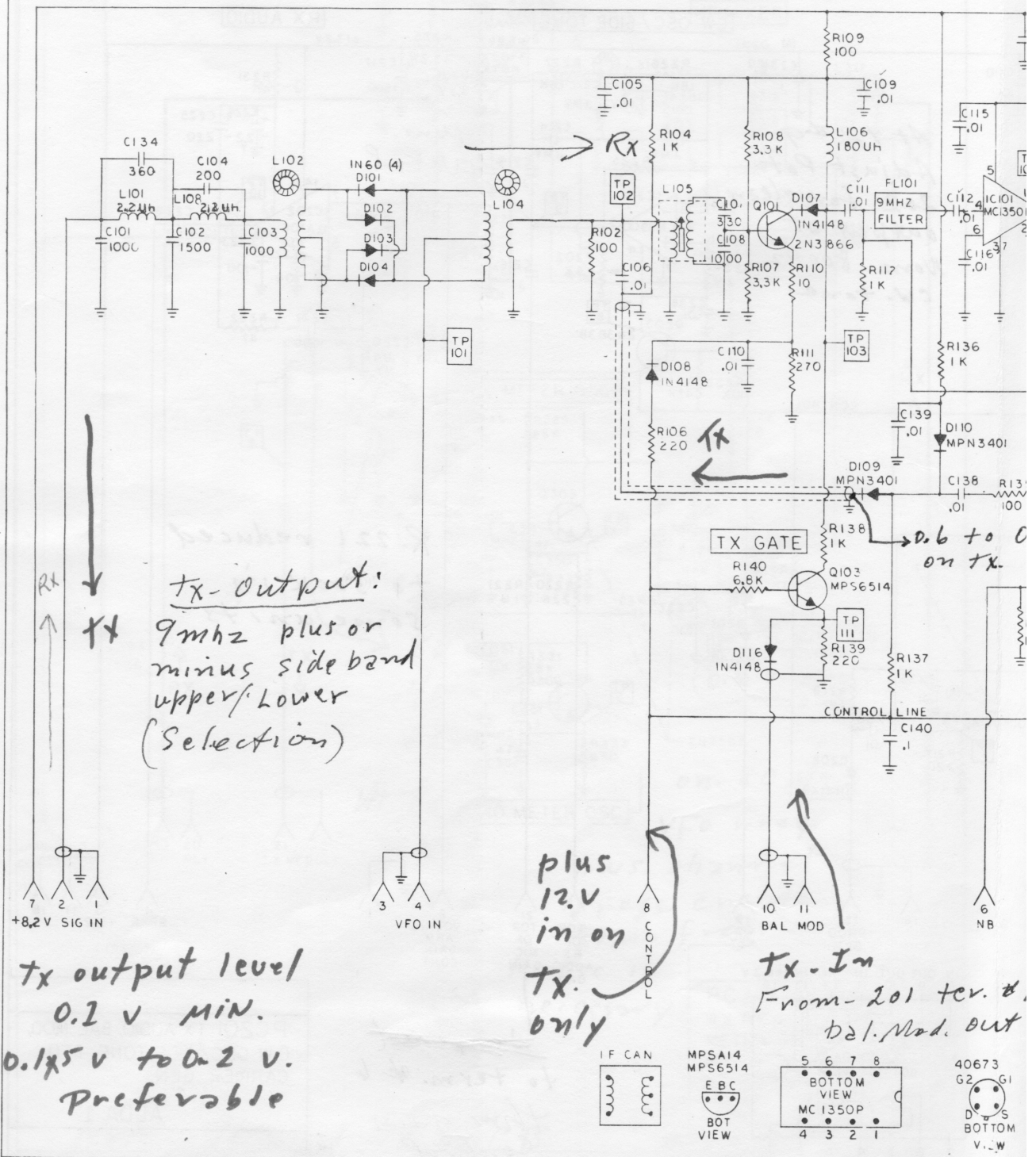

R_x ↓
 T_x ↑
TX-Output:
 9mhz plus or minus side band upper/lower (Selection)

Tx output level
 0.1 v min.
 0.1x5 v to 0.2 v.
 preferable

plus
 12.v
 in on
 TX.
 only

Tx-Im
 From-201 rev. #.
 bal. Mod. out

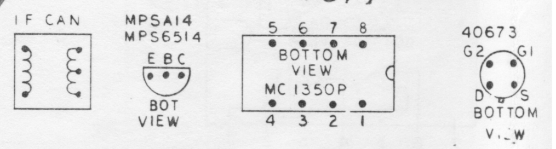

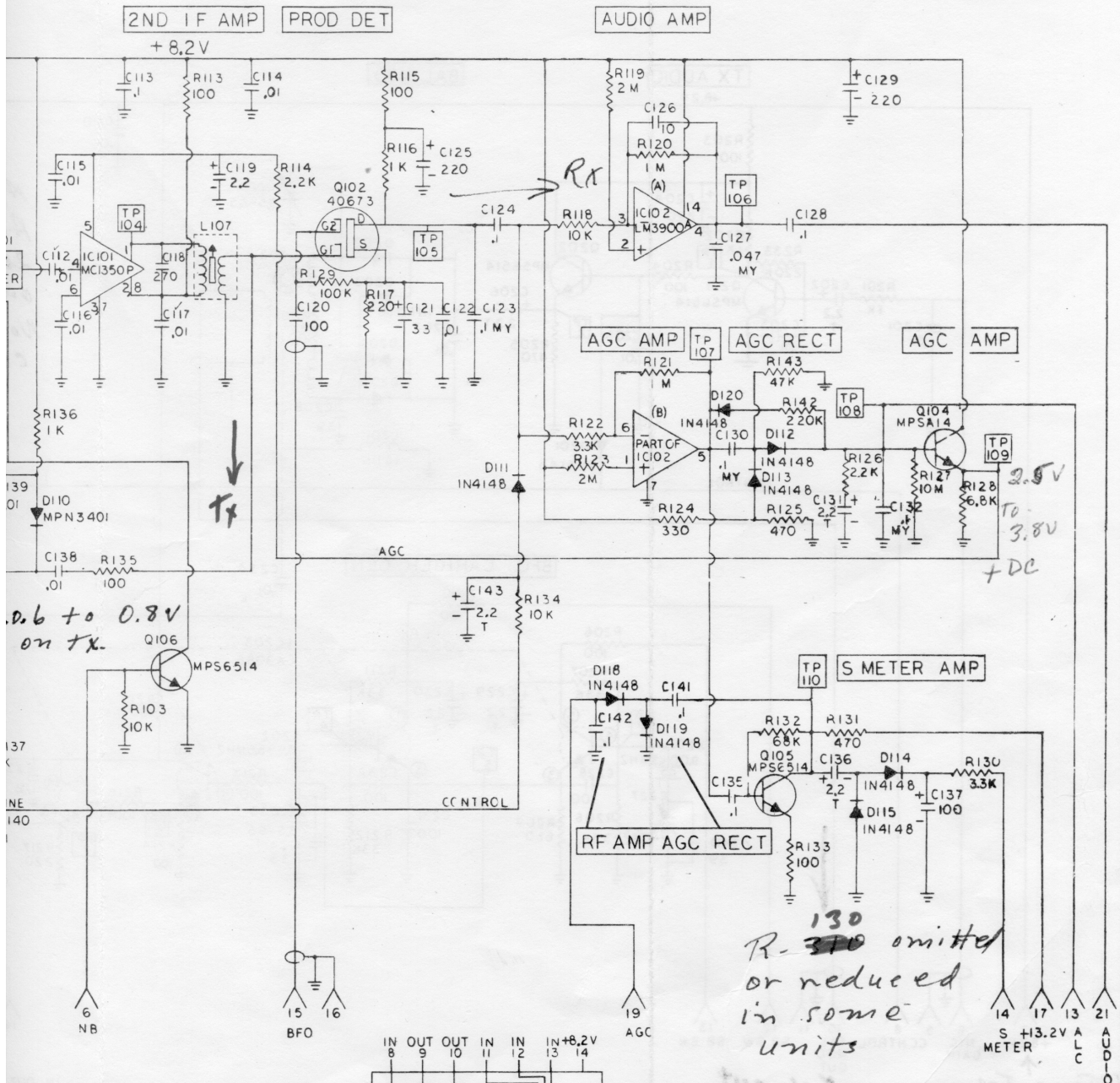

0.6 to 0.8V on TX.

130 R-370 omitted or reduced in some units

1 rev. #10. Prod. OUT

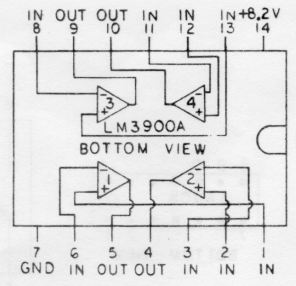
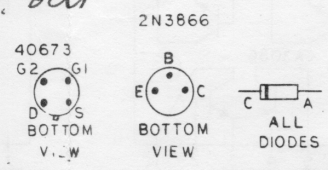

PC101 BAL MIX, NB GATE, 1ST IF AMP, 2ND IF AMP, PROD DET, AUDIO AMP, AGC AMP, AGC RECT, AGC AMP, TX GATE, S MET AMP, RF AMP, AGC RECT

ALDA 1

Balance Carrier - by adjusting
measure RF out at load with
500

Notes:

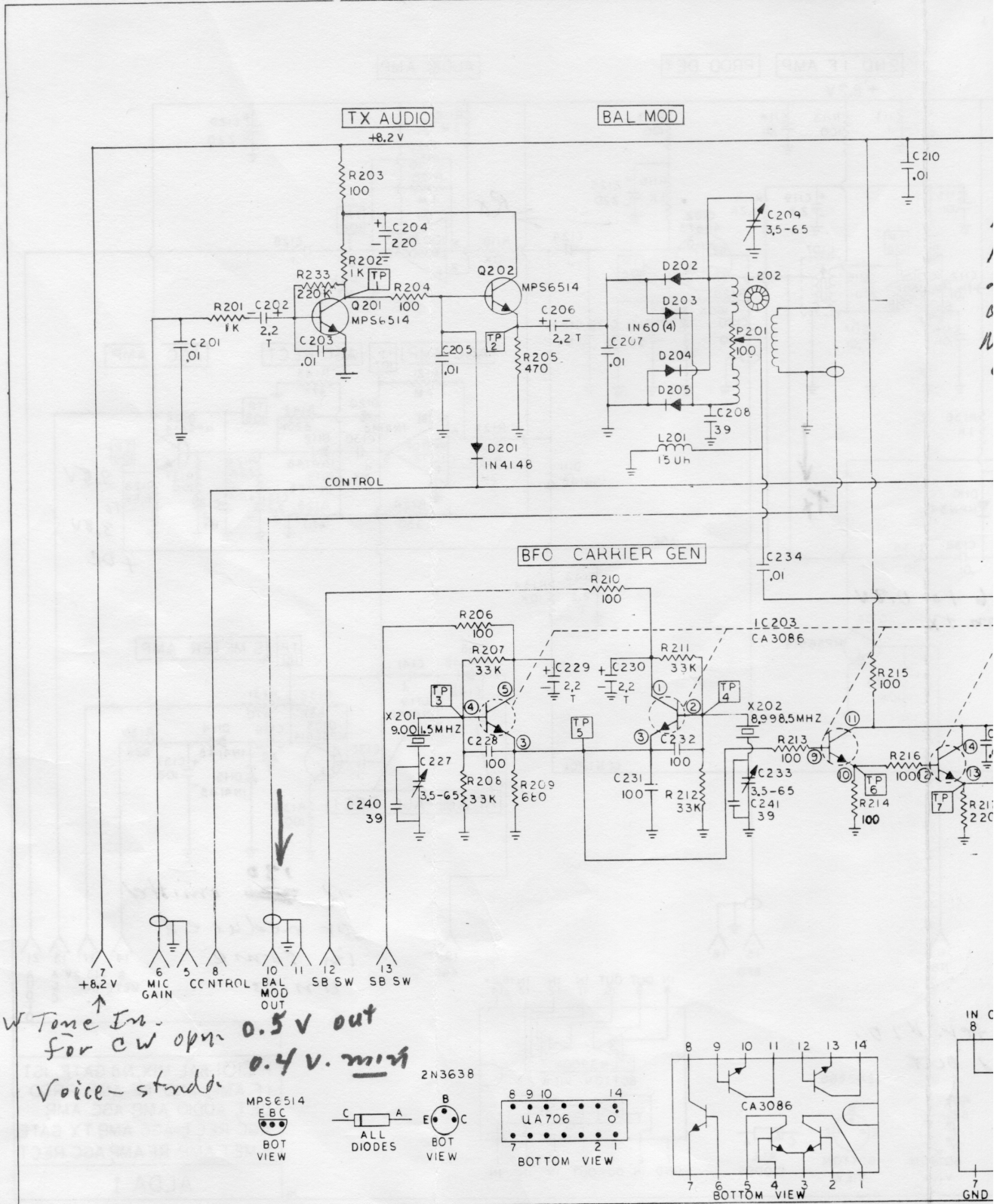

justing for null. C-209 x R201 switching "Upper" x "Lower" Side band
 l. with VTVM--(No signal in) Max. 2V RMS. allowed.

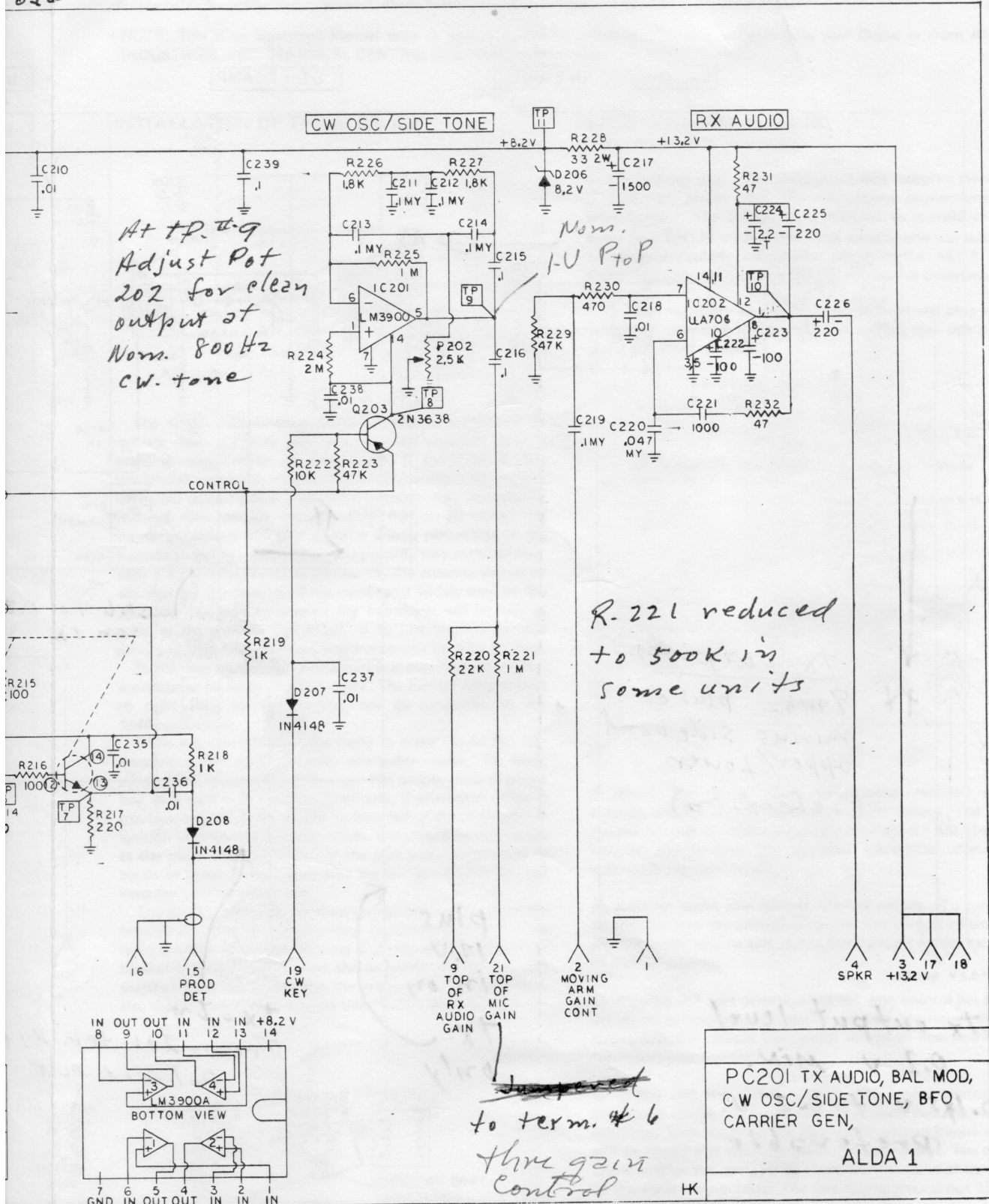

PC201 TX AUDIO, BAL MOD,
 CW OSC/SIDE TONE, BFO
 CARRIER GEN,
 ALDA 1

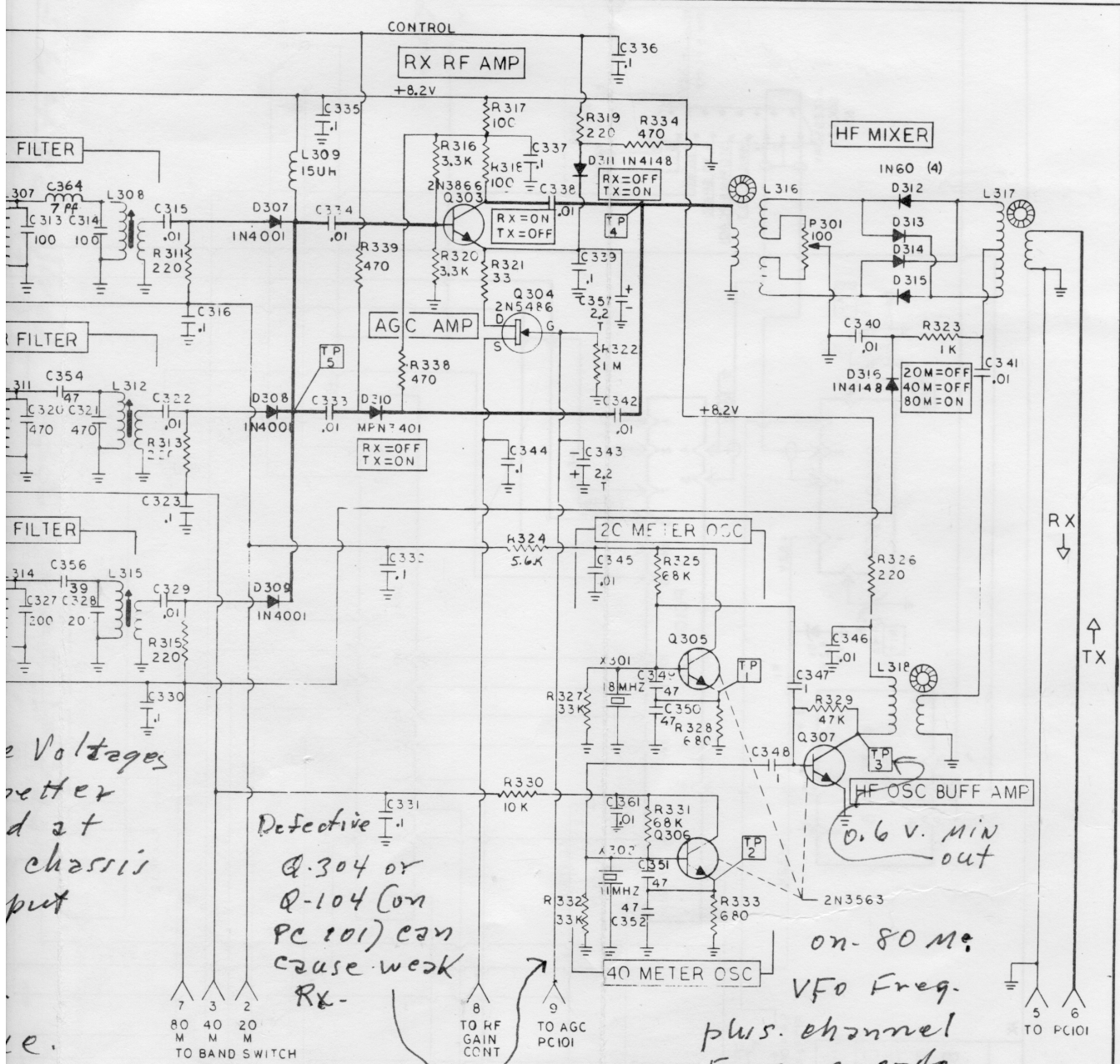

e Voltages
 better
 d at
 chassis
 put

Defective
 Q.304 or
 Q-104 (on
 PC 101) can
 cause weak
 Rx-

0.6 v. MIN out

on-80 Mc

Vfo Freq.
 plus. channel
 Freqs. create
 80M-freq. -

+12.v Applied to
 selected band for
 diode sw. turn-on.

No osc. is
 necessary.

PC301 TX AMP, AGC AMP,
 RX RF AMP, HF MIXER, 20
 METER OSC, 40 METER OSC,
 HF OSC BUFF AMP, 20, 40 &
 80 METER FILTERS.
 ALDA 1

being/blocking diodes on this PCB.

2 x Q308. Some of these will show up

HK

Notes: Over +6V. DC at collector of Q302 usually indicates defective unit. - (Open) -

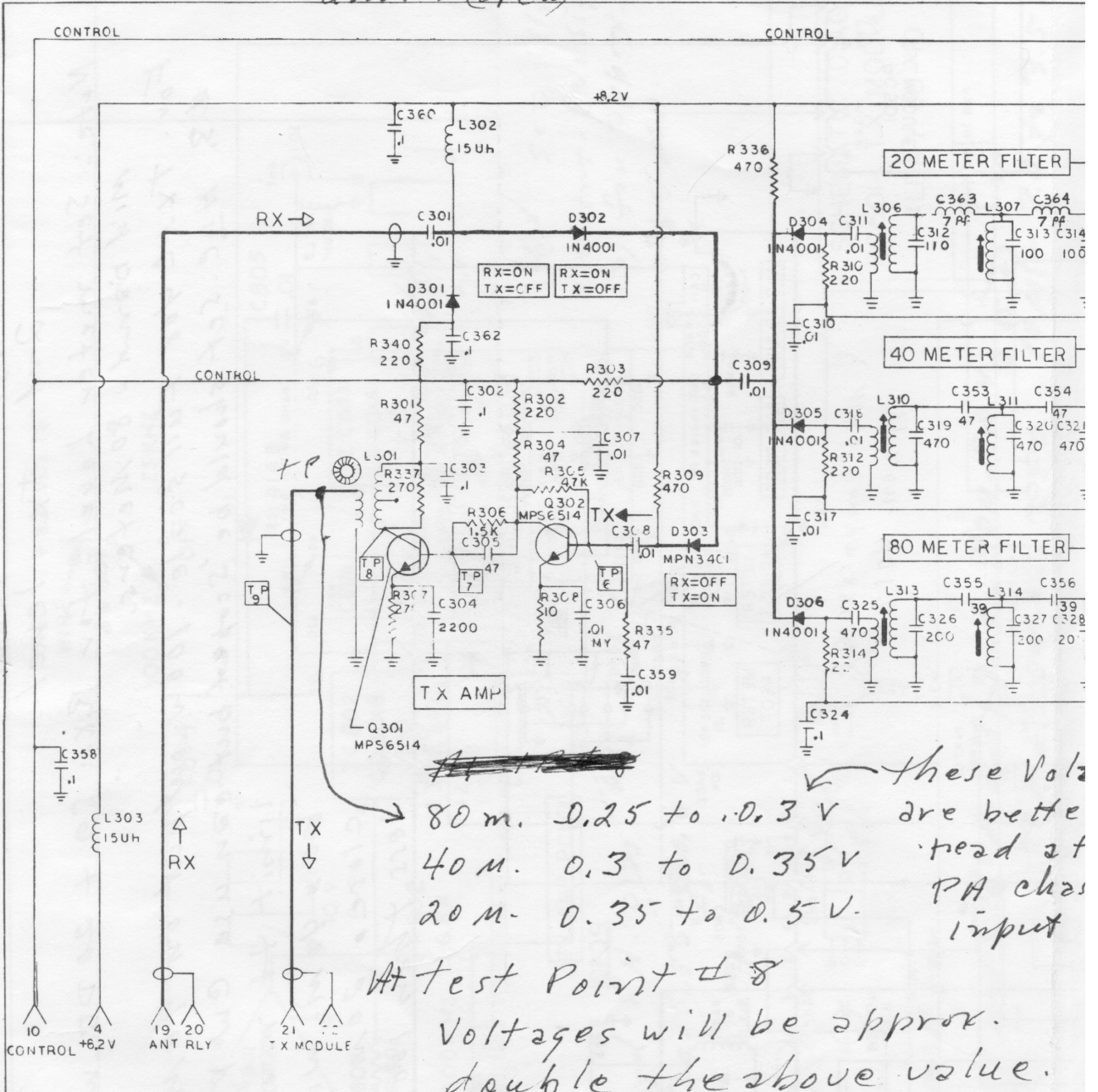

~~At test point 8~~
 At test point 8
 Voltages will be approx. double the above value.

These Voltages
 80m. 0.25 to 0.3V are better
 40m. 0.3 to 0.35V head at PA chas
 20m. 0.35 to 0.5V. input

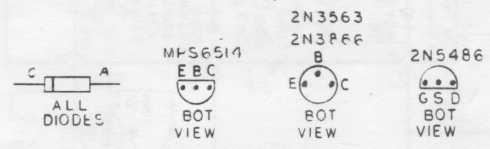

Note: 90% of Tx problems are faulty switching/ combined with defective 6514s. Q302 x Q ds. cause of weak Rx also.

Sig. Level. Meter Adjust

First- RX level
2nd- TX level.

Note: Set meter level- for Rx: 59 + 20 DB. with 50 Kvar.
Mid band - 80 Meters.

For. Tx. 2908 Full scale - 100w output on 40M. Midband
#3. ALC. Set should be 'Scope' but can use CW power out to
limit to. max 115w - on
80 yam. will be fairly
close 20m may show
less than 100w. - 10. max

(microvolts)

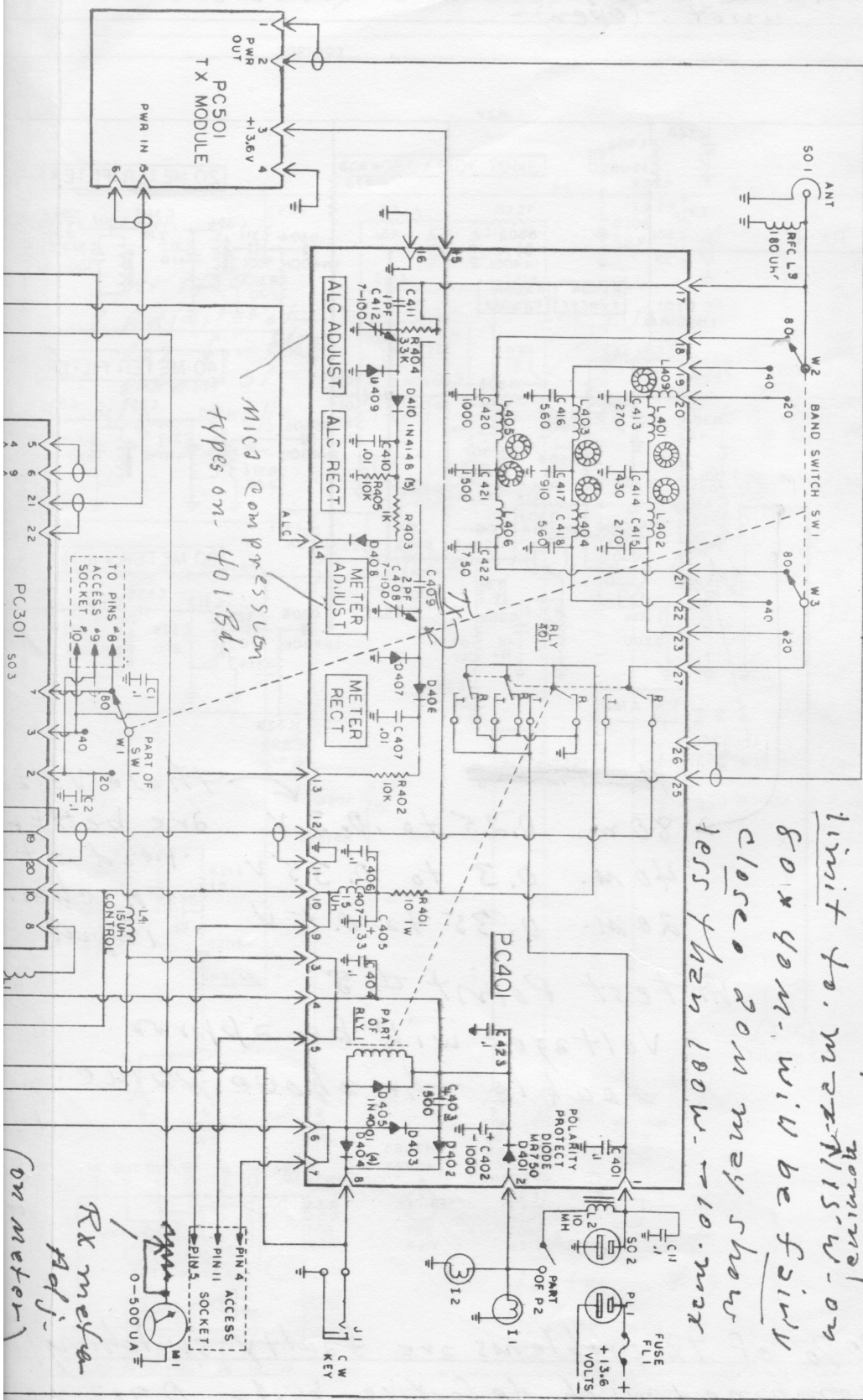

MIC Compression
types on 401 Bd.

Rx meter
Adj.
(on meter)

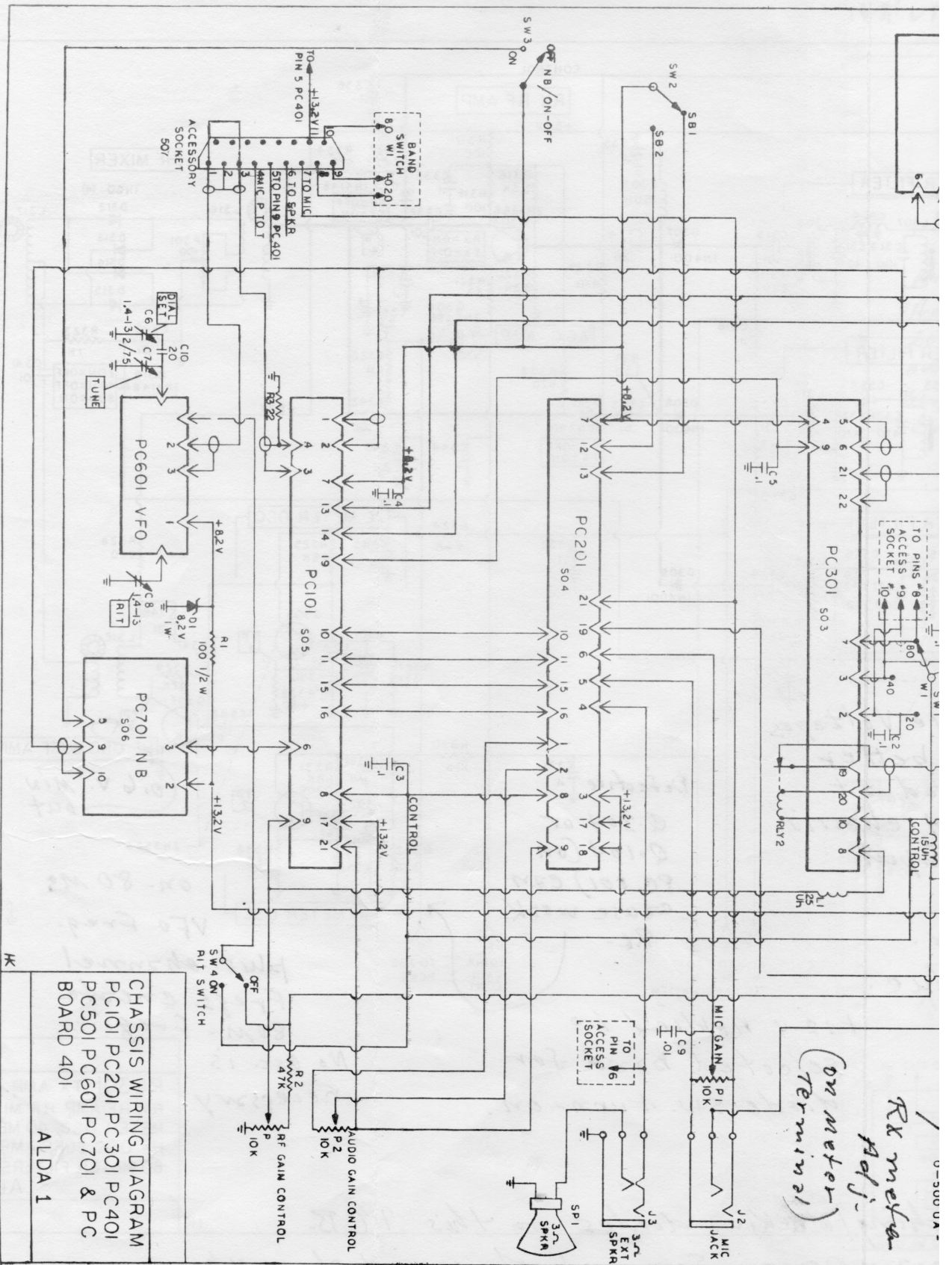

CHASSIS WIRING DIAGRAM
 PC101 PC201 PC301 PC401
 PC501 PC601 PC701 & PC
 BOARD 401
 ALDA 1

*Rx meter
 Adj. (on meter
 terminal)*

0-300 U.A.

6) **Dial.** The dial is calibrated directly in 5 KHz steps. The top (white) scale is used when operating the 7 Mhz and 14 Mhz amateur bands. If the bandswitch is set to 7 Mhz and the dial scale reads 150 the frequency is 7150 KHz. The red scale is used when operating the 3.5 mHz band. Note that the bandswitch 3.5 KHz indicator is also printed in red enabling the operator to instantly recognize the scale to be used.

7) **Bandswitch.** The bandswitch frequencies are indicated in two colors. When using the figures in the red box the red dial scale is the scale to be used. Likewise, the indicators in the red sideband selector box indicate the correct position of the sideband selector switch. For example, if the bandswitch is set to 3.5 Mhz (red box) the red dial scale is used and the sideband selector switch should use the sideband designation in the red box.

8) **Sideband Selector Switch.** Refer to the comments above. Note that when the sideband selector switch is changed from one sideband to the other a small shift in frequency takes place and it will thus be necessary to make a small change to the tuning.

In the CW condition an 800 Hz tone is transmitted. If the sideband selector switch is set to lower, the tone will be transmitted 800 Hz lower in frequency than the carrier frequency. Conversely, if the switch is set to upper, the tone will be 800 Hz higher than the carrier frequency. This system has the major advantage that the CW is automatically sidestepped so that it should not be necessary to retune when switching from SSB to CW. Additionally, as there is no established standard, some transceivers always transmit their tone on the upper sideband while others transmit on the lower. Still other transmitters reinsert carrier. The flexibility offered in the ALDA 103 enables the operator to meet the other station on his own ground, so to speak.

9) **Receiver Incremental Tuning.** The RIT control is activated when the RIT switch 10) is placed to the upper (on) position. This control enables the operator to adjust the receiver frequency without changing the transmit frequency. This feature will be particularly enjoyed by the serious CW operator as it enables him to select his own tone frequency or drop out an interfering heterodyne. When the RIT switch is placed to the lower (off) position the transmitter and receiver will be on the same frequency.

10) **RIT On/Off switch.** See 9) above.

11) **Dial Set.** The dial set control enables the operator to set the dial read out exactly to frequency. However, it should be realized that because the dial set control is a variable capacitor connected across the VFO coil it will have a little more effect at the high frequency end of the VFO than at the low frequency. Thus, as the receiver ages and the VFO long term drift is corrected with the dial set control, a certain amount of non linearity of the dial reading will take place.

12) **Noise Blanker Switch.** The noise blanker is automatically activated when the switch is placed to the upper (on) position. The blanker is of a type that does not require a threshold control. The noise blanker circuit contains an automatic kind of AGC system which tends to reduce cross modulation. However, in some instances, as in all noise blankers, some cross modulation may occur. Consequently, the noise blanker should be used only when necessary.

The particular noise blanker circuit used will also be found effective against certain kinds of power line interference.

13) **Microphone/CW gain control.** The microphone gain control operates in the normal way. Because the transceiver is fitted with ALC, *provided the antenna is properly matched*, no interference to others will be produced if the control is operated fully up. However, under these circumstances the background noise may well become objectionable. Although no hard and fast rule can be made due to the differences in microphones, antenna matching and operator voices, a setting somewhere about half way is recommended as a starting point. Obviously, the best method of setting the control is to use an oscilloscope.

When using CW, the control sets the transmitted tone level. However, due to the small size of the transceiver and consequent reduced heat sink area it is recommended that the control be set to give a meter reading of about 5 or 6 when the CW key is held down. It is recommended that the operator feel the heat sink at the rear of the radio. If you can bear your hand upon the heat sink for a minute or more you are operating the transceiver safely.

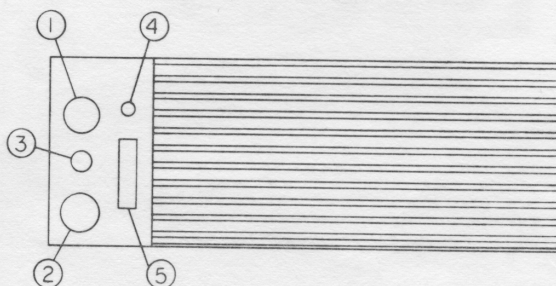

Refer to the rear panel layout.

1) **Antenna socket.** The transceiver is designed to operate into a 50 ohm load with a VSWR no greater than 1.5 to 1.

2) **Power Connector.** The ALDA 103 is designed to operate from a 13.6 volt 20 amps peak, 7 amps average power source. The transceiver may safely be operated with a supply voltage as high as 16 volts without damage. A power cord and an in-line fuse is supplied. The fuse type is 3AG rated at 20 amps slow-blow. If a different power cord is used the transceiver must be suitably fused.

When operated from the ALDA 103 Power Supply PS1 an in-line fuse is not required as the power supply is separately fused.

The ALDA 103 transceiver is suitably protected against power supply polarity reversal.

When a black and white power cord is supplied with the radio the white wire should be connected to the positive terminal.

3) **CW Key Jack.** Once the CW key plug is inserted it is only necessary to press the key to transmit CW. There are no knobs or adjustments to make except to vary the level of the sidetone for comfortable listening and to adjust the transmitted CW output power to the liking of the operator. These adjustments were covered in the preceding paragraphs 3) and 12).

Note that the ALDA 103 uses break-in keying. Once the key is pressed, the transceiver will go to the transmit position and stay there between characters and words but will return automatically to receive when the operator pauses.

4) **Extension Speaker/Headphone jack.** The internal speaker is automatically cut off when a plug is inserted. An extension speaker should have an impedance of 3 ohms. Headphones should be low impedance.

5) **Accessory socket.** This socket has been provided for future accessories and to obtain control voltages for the control of a linear amplifier. Refer to the Maintenance Manual for further information.

WARRANTY

ALD Industries warrants this equipment against defects in material or workmanship, for a period of 1 year from date of original purchase on parts and labor except 90 days on solid state devices. To establish date of purchase buyers should fill in the warranty card supplied with the transceiver and return it to the factory within 7 days of purchase. Do not ship the transceiver to the factory without prior consent. All returns must be sent freight prepaid. Provided the repairs are covered under the warranty, ALD Industries will pay the return freight. This warranty is limited to repairing or replacing only defective components and is not valid if the equipment has been tampered with, misused or damaged.

ACCESSORY SOCKET CONNECTIONS
Accessory Socket — Viewed From Rear of ALDA 103

0	0	0
12	11	10
0	0	0
9	8	7
0	0	0
6	5	4
0	0	0
3	2	1

MATING PLUG ALDA P/N 610012 — WINCHESTER P/N 56-12P1000
INSERT PINS ALDA P/N 610010 — WINCHESTER P/N 156-1024P

PIN NO.	CONNECTION AND FUNCTION
1	INTERNAL VFO OUTPUT
2	GROUND
3	REMOTE VFO INPUT OR JUMPER TO PIN 1
4	PTT LINE (REMOTE KEYING OF 103 OR KEYLINE TO EXTERNAL AMPLIFIER)
5	CONTROL LINE (GROUND ON RCV/+13 VDC ON XMT)
6	RECEIVER AUDIO OUTPUT (3 OHMS IMPEDANCE)
7	TRANSMITTER AUDIO INPUT (3K OHMS IMPEDANCE)
8	+13 VDC ON 80 METERS (FOR REMOTELY SWITCHED ANT. TUNER)
9	+13 VDC ON 20 METERS (FOR REMOTELY SWITCHED ANT. TUNER)
10	+13 VDC ON 40 METERS (FOR REMOTELY SWITCHED ANT. TUNER)
11	+13 VDC ON RCV AND XMT
12	BLANK