



**INSTRUCTION  
MANUAL**

**MODEL 5100 TRANSMITTER**

**BARKER & WILLIAMSON, Inc.**

**237 FAIRFIELD AVENUE  
UPPER DARBY, PENNA.**

## PUTTING YOUR B&W TRANSMITTER ON THE AIR

1. After the equipment has been carefully removed from its packing box—be sure all tubes are in their respective sockets and pushed firmly into place.
2. The equipment as shipped from the factory comes to you ready to operate, with the exception of—crystals, microphone, key and antenna.
3. Before plugging the power line cord into a 115 volt A.C. 60 cycle single phase power source receptacle be sure that the A.C. line switch and the plate **on** and **off** switches are in the **off** position.
4. **Take time to be sure** you thoroughly understand the function of each control.
5. Before attempting to place the transmitter in operation and on the air, **be sure** you have a suitable antenna or dummy load connected to the output power connector.
6. For phone operation, a microphone should be connected to the microphone connector on the front panel.
7. For C.W. operation, a key with cord and suitable plug should be inserted in the key jack on the front panel.
8. For crystal operation on phone or C.W., a suitable 80 meter crystal is to be inserted in the crystal holder — located inside the cabinet on the crystal-buffer-amplifier unit and the crystal-VFO selector switch near the crystal holder is thrown in the crystal position.
9. For VFO operation on Phone or C.W., the **crystal is removed** and the Crystal-VFO selector switch is thrown in the VFO position.
10. Turn the A.C. line switch to the **on** position and make sure all tubes are lit. Allow tube filaments to run at least ten minutes when the equipment is first turned on.
11. Proceed as directed under operating instructions.

### NOTICE

#### A FEW DONT'S TO REMEMBER

- A. **Do not** turn the **Master Band Selector Switch** when the plate switch is in the **on** position.
- B. **Do not** attempt to tune and operate the transmitter in VFO position unless you are sure that the **Frequency Control Dial Pointer** is correctly set on the appropriate frequency of each band corresponding to the **Master Band Selector Switch** — for crystal operation, make certain that a crystal of proper output freq. is chosen.
- C. **Do not** attempt to make connections to the rear terminal strip on back of the chassis apron unless the A.C. line cord plug is removed from the power source.
- D. **Do not** use the receiver disabling circuit nor the remote relay connections for conducting or breaking high current. Doing so will result in damage to the internal control relay contact points.
- E. **Do not** make the error of reversing the push-to-talk connections when assembling the microphone plug, since the relay voltage present could damage the microphone. (See instructions elsewhere in this manual under microphone connector.)
- F. **Do not** attempt to operate the equipment without a good ground attached to the ground terminal of the equipment.

### WARNING

Death or serious injury may result if operators fail to observe safety precautions. Extreme **caution** is to be exercised during any observations or voltage measurements around live power circuits carrying \*lethal voltages. Failure to observe all safety regulations may result in personal injury, if not loss of life.

\*Underwriters regulations consider lethal any potential above 24 volts.

### INTRODUCTION

The model 5100 transmitter has been designed for amateur communications service covering both radiotelephone and telegraph within the confines of the amateur frequency bands 80-40-20-15-11 and 10 meters. It is a compact, bandswitched, VFO or crystal controlled, self contained equipment containing all of the latest engineering advances leading toward the effective transmissions of signals with a minimum of harmonic content for prevention of television interference. Mainly intended for permanent station operation, the external source of power required for its operation is 115 volts, 50/60 A.C. It has been designed with a view toward striking appearance, high quality of workmanship, trouble free operation, ease of control and tuning and last, but not least for servicing, its unitized construction permits quick access and easy removal of any major section with minimum disturbance to other sections. The model 5100 transmitter may also be used to drive a higher powered R.F. final amplifier and class "B" audio modulator.

Its consistent operation coupled with an excellent quality of signal output, will meet all of the requirements of the most discriminating operator.

## SUMMARY OF VARIOUS SECTIONS

### Radio Frequency Section

The radio frequency section of the model 5100 consists of three separate units. First, the variable frequency oscillator (VFO) with the calibrated scale to read the frequency for each of the six amateur bands covered. Second, a buffer amplifier-crystal oscillator-keying tube unit which functions as a buffer amplifier when VFO operation is selected and as a crystal oscillator when operating in the crystal position. This unit also performs the function of block grid keying when either VFO or crystal operation is selected for CW operation. Third, the multiplier-final amplifier unit, the function of which is to multiply and amplify the selected output frequency.

### Speech Amplifier-Modulator Unit

The speech amplifier modulator is a separate unit consisting of 4 tubes in a compact subassembly providing speech amplification from a crystal microphone and ample audio power to fully modulate the RF power output under maximum power conditions.

### Power Supplies

Power supplies are of the conventional type utilizing heavy duty transformers and chokes and other components designed for typical amateur operation at maximum power. Two distinctly separate power supplies are used, the high voltage supply furnishing plate voltage for the R.F. final amplifier, modulators and multiplier stages, while a low voltage power supply provides the low potential D.C. and bias voltage as required. Provision has been made for front panel control of high voltage reduction during tune-up procedure.

### TVI Suppression

Television interference suppression has been carried out to a degree found necessary by B&W's experience in this field. Precautions have been taken to prevent radiation from the more critical leads coming from the transmitter cabinet. Functional design within the R.F.

section has been along lines which eliminate the source of much TVI. In addition to the details outlined above, the model 5100 contains as an integral part, a low pass filter which provides a minimum of 85 D.B. attenuation throughout the normal television channels with over 100 D.B. attenuation on channel #2.

### Front Panel

The front panel contains the following controls — the A.C. line switch, tune operate switch, meter selector switch, microphone input jack, audio gain control, key jack, function switch, pilot light, plate power switch, master band selector, loading control, excitation control, plate tuning control, and main VFO frequency control dial clearly marked and printed to indicate all six bands. Also included is an all purpose meter which registers amplifier screen grid current, amplifier plate current and modulator plate current. Accessible through the rear of the cabinet are the A.C. cord, antenna connector and remote control line connection terminals. All rotating controls on the panel are equipped with richly styled machined aluminum knobs, with knurled edges.

### Cabinet

The beautifully styled cabinet, finished in silver blue hammertone with gray panel, has rounded edges and corners and a hinged flush fitting lid providing access to the interior of the equipment for such functions as changing crystals and tube replacements, inspection etc. It is made of heavy gauge steel properly reinforced to adequately support the entire structure of the main chassis and associated subassemblies.

### Dial Mechanism

The main frequency control dial which operates the VFO is a friction drive unit, extremely smooth in operation and permitting adjustment of frequency at the will of the operator.

## SPECIFICATIONS

Frequency Coverage	$\frac{80 \text{ meters}}{3.5-4.0\text{mc}}$	$\frac{40 \text{ meters}}{7.0-7.3\text{mc}}$	$\frac{20 \text{ meters}}{14.0-14.35\text{mc}}$
	$\frac{15 \text{ meters}}{21.0-21.45\text{mc}}$	$\frac{11 \text{ meters}}{26.96-27.23\text{mc}}$	$\frac{10 \text{ meters}}{28.0-29.7\text{mc}}$

Complete bandswitching on all bands.  
 VFO or crystal operation on AM or CW.  
 Power input — 135 watts phone — 150 watts CW.  
 PI-network output.  
 Built-in low pass filter.  
 TVI suppressed.  
 Stable VFO with accurately calibrated scale.  
 Output impedance — 75 ohms unbalanced.  
 External audio power output — 75 watts — Impedance 500 ohms.  
 Power source nominal — 110 volts single phase 50/60 cycles A.C.  
 Size — Width - 22" — Height - 11 $\frac{1}{2}$ " — Depth - 14 $\frac{3}{4}$ ".  
 Net weight — approximately 83 lbs.  
 Shipping weight — 90 lbs.

### Tube Complement

VFO — 1 - Type 6BJ6  
 Crystal Oscillator Buffer Amplifier — 2 - Type 6BJ6  
 Multiplier — RF Amplifier — 4 - Type 6AQ5 - 2 Type 6146  
 Speech Amplifier — Modulator 1 - Type 6U8, 1 - Type 6AQ5, 2 - Type 6146  
 Low Voltage Power Supply — 1 - Type 5V4G  
 High Voltage Power Supply — 2 - Type 5R4GY  
 Voltage Regulators — 1 - Type VR150, 1 - Type VR105

## DESCRIPTION AND FUNCTION OF VARIOUS SECTIONS

### VARIABLE FREQUENCY OSCILLATOR

The variable frequency oscillator unit utilizes a type 6BJ6 tube in a Hartley type circuit, generating a fundamental frequency range between 1680 to 2005 KC.

The output frequency, through the medium of doubling is twice the value of the fundamental oscillator range, thus providing an output range equal to a low value of 3360 KC to a high of 4010 KC. This basic output range of frequencies, when multiplied covers all amateur frequencies within the limits of the amateur bands 80 - 40 - 20 - 15 - 11 and 10 meters.

The variable capacitor used in this unit has been designed to provide straight line frequency variation with respect to its rotation. The D.C. voltage for powering this unit is regulated by means of a VR-150 voltage regulator tube in the main low voltage power supply.

### BUFFER-AMPLIFIER-CRYSTAL-OSCILLATOR- KEYING-TUBE-UNIT

This compact unit performs several functions. The first of two 6BJ6 type tubes used, performs as a buffer amplifier, while the second 6BJ6 is used as a crystal oscillator, second buffer and keyer tube. During VFO operation, the second 6BJ6 tube functions as an additional

### FREQUENCY MULTIPLIER — FINAL AMPLIFIER

This unit which is driven by the output of the buffer amplifier-crystal oscillator-keyer tube unit, functions as a frequency multiplier and final amplifier.

The frequency multiplier section of this unit consists of 4 type 6AQ5 tubes in a broad-banded circuit eliminating the need of tuning each of the multiplier stages over the entire operating frequency range of the over-all equipment. This feature keeps tuning controls to a minimum. Selection of the multiplier stages is made through use of a switch which is ganged to the main band selector switch. Hence selection of the appropriate multiplier stages and final bandswitching is accomplished in one operation by the simple twist of one knob.

The power amplifier section of this unit employs two type 6146 beam power tubes in parallel providing the RF power output through a PI-network circuit.

Bandswitching is accomplished through the medium of a rotary type switch which as pointed out above is ganged to the multiplier section enabling simultaneous switching of the multiplier sections and the final amplifier. The PI-network in the output circuit enables loading and tuning adjustments to be made for compensating nominal

buffer stage, thus enhancing isolation between the VFO and the multiplier sections. In either case, VFO or crystal operation, the second 6BJ6 tube additionally functions as a keyer tube. This unit is driven by the variable frequency oscillator. The circuitry includes a band-pass filter for the purpose of attenuating fundamental oscillation frequencies, thus transferring only the desirable 80 meter signals required for the multiplier.

The VFO-crystal selector switch and crystal holder are located on the top of this unit in a convenient position for quick change-over from VFO to crystal or vice-versa. When crystal operation is desired, an 80 meter crystal providing fundamental or desired harmonic frequency, is inserted in the crystal holder and the VFO-crystal selector switch is thrown to the crystal position. When the VFO-crystal selector switch is in the crystal position, it functions to de-energize the first buffer and VFO while the second 6BJ6 tube then functions as a Pierce type oscillator.

The circuit has been designed to operate with 80 meter crystals, hence, the output frequency of the transmitter is either the basic crystal frequency or its multiples, depending on the setting of the band selector switch, which in part, functions to select the appropriate multiplier stages.

It is important to remove the crystal from its holder, during VFO operation on phone or CW.

variations in the antenna feed line system.

An excitation control in the grid circuit of the power amplifier stage is provided for effecting proper adjustment for the most efficient driving power as required for each individual band.

When the power amplifier is used in CW operation, the screen voltage is supplied by a constant source from the low voltage supply. However, when the power amplifier is modulated, the screen voltage is supplied from the high voltage supply by means of dropping resistors, so that plate and screen are modulated simultaneously. The circuitry of the multiplier and power amplifier has been designed to minimize spurious radiations.

All leads in the three units described above, constituting the complete RF section of this equipment, have been carefully filtered and shielded to minimize leakage and radiation. The mechanical construction of all three RF units as well as the speech amplifier-modulator unit have been designed with a view towards quick and easy removal of each individual unit, for purposes of inspection and service, with minimum disturbance to other functional units of the over-all equipment.

## SPEECH AMPLIFIER — MODULATOR UNIT

### SPEECH AMPLIFIER

The speech amplifier-section of this unit employs a type 6U8 triodepentode tube, the triode section of which is used as the preamplifier stage and the pentode section as a high gain second stage in order to obtain driving voltage for a type 6AQ5 tube functioning as a transformer coupled driver.

The volume control for governing the audio level is placed in the circuit between the triode and pentode sections of the dual purpose 6U8 speech amplifier tube. The audio power obtainable from the speech amplifier is more than ample to fully excite the 6AQ5 driver stage when a low level crystal microphone is used.

### MODULATOR

The modulator portion of this unit is composed of two type 6146 beam power tubes, operating in class AB2.

The speech amplifier and modulator system provides approximately 75 watts of audio power, a greater amount than is required for 100% modulation of the R.F. amplifier operating at maximum power input. This audio power is also available for external use in driving a high powered modulator. The external output impedance through terminal strip connections on the rear chassis apron is 500 ohms. Precautions have been taken to completely shield this unit as well as filter its connecting leads in order that no difficulty due to RF feed-back is experienced.

## POWER SUPPLIES

### HIGH VOLTAGE SUPPLY

The high voltage power supply used for powering the RF amplifier, modulator and multiplier section delivers a nominal potential of 600 volts D.C. Two type 5R4GY tubes are employed in a full wave circuit together with a conventional type filter.

For purposes of improved filtering and better regulation, the filter reactor has been resonated at approximately 120 cycles by means of a shunt condenser. A bleeder is utilized across the output of the high voltage supply for discharging the residual charge in the filter capacitor section.

For tune up purposes, a resistor is employed in series with the primary of this supply, thus reducing the high voltage to a safe value. The control of these two levels of potential is through the panel mounted tune-operate switch.

### LOW VOLTAGE SUPPLY

The low voltage power supply is a separate unit. It is used to furnish the plate power to the variable frequency oscillator, buffer-amplifier-crystal oscillator, speech amplifier, audio driver, modulator driver and the screens of the modulators.

In addition to the above, this power supply also delivers the required bias voltage for both the modulator and RF amplifier. In the CW operating position, this supply also provides the screen voltage for the RF power amplifier.

## OPERATING INSTRUCTIONS

### PHONE OPERATION

1. With either a suitable crystal inserted in the holder for crystal operation or the VFO adjusted to the desired frequency, the main band selector switch should be set to the proper band of operation.
2. Throw the A.C. line switch to the **on** position and allow tubes to warm up for at least two full minutes, meanwhile, throw the **tune operate switch** to the **tune position**, the meter switch to the **amp.** position and the **function switch** to phone position. The **load control knob** should be set at **zero**.
3. Throw the plate switch to the **on position** and adjust the plate tuning control to show a minimum meter reading. The **tune operate switch** should now be set to **operate**. The **loading control** should now be turned slowly toward ten and the plate tuning again adjusted for minimum. This procedure should be repeated until a reading of 200 is indicated by the meter.
4. Turn the meter switch to the **grid position** and **exc. control** until meter indicates approximately **17 mils**. Meter should now be switched to the **amp. position**. The **loading and plate tuning controls** should again be adjusted as outlined above, until a meter reading of 220 mils. is obtained. This indicates that the final is loading and power is flowing into either the dummy load or antenna, whichever is used.
5. When lower power output is desired, the **loading and plate tuning controls** should be adjusted accordingly as outlined in paragraphs 3 and 4 until the plate current as indicated by the meter registers proportionately with respect to the output power desired.
6. The transmitter is now ready to be modulated and the operator should proceed as follows:
  - A) Advance the audio gain control knob.
  - B) Turn meter selector switch to **mod. position**. This will indicate modulator resting plate current.
  - C) While speaking into the microphone with normal voice, proceed to adjust the **audio gain control** to a point where the peak increase under modulation as indicated by the meter does not exceed 100 mils.

The modulator has sufficient audio power to more than fully modulate the maximum power input of the RF power amplifier, hence, the possibility of over-modulation should be avoided by keeping the audio gain control in a position which permits just enough audio power output to be generated for 100% modulation of the RF power amplifier.

The process as outlined above covers phone operation on crystal or VFO and applies to all bands.

## OPERATING INSTRUCTIONS

### C. W. OPERATION

1. Proceed to tune the transmitter as outlined in the preceding paragraphs, after which the function switch should be turned to the C.W. position.
2. In C.W. operation the microphone remains connected, but unused and a telegraph key is plugged into the key jack as follows —
  - A) Insert the key plug into the **key jack**.
  - B) **Retard audio gain control knob to minimum.**
  - C) Turn the meter switch to the **amp. position**. When the plate switch is thrown to the **on** position, the **key** will further take control with respect to operation of the transmitter output.
3. In C.W. operation on any band, with key-up conditions, the oscillator is blocked and the power amplifier is biased to a safe value. Hence, under key-up conditions, the meter indication will be low, but normal under key down conditions.
4. Crystals for operation on the 40-20-15-11 and 10 meter amateur bands must always be of the 80 meter fundamental type. When the operator desires to operate on crystal at a specific frequency in any of these bands an 80 meter crystal which multiplies to the desired frequency of the chosen band **should be selected**.

### DESCRIPTION AND FUNCTIONAL SUMMARY OF VARIOUS FRONT PANEL CONTROLS AND SWITCHES

Reading from left to right the bottom row of controls and switches functions as follows:—

1. **The A.C. line switch**  
This switch is used to break the primary circuit of the low voltage power supply. When this switch is in the **on** position the low voltage power supply is energized, thus, furnishing all filament and plate voltages for the VFO, crystal-oscillator-buffer-amplifier unit, speech amplifier, audio driver, modulator driver, screen voltage for the modulator tubes and bias voltage for modulator and RF amplifier tubes.
2. **Tune operate switch**  
This switch functions as a shunt for a resistor in the primary circuit of the high voltage power supply. When this switch is in the **tune position** it places the resistor in series with the primary winding, thus reducing the input voltage to a value sufficient for safe reduction of the high D.C. potential. When it is in the **operate** position, it shunts the resistor allowing the full primary voltage to be applied for use under normal operating conditions.
3. **Meter switch**  
This three position switch functions to place the indicating **meter** in three separate circuits. In the **grid position**, the meter is in series with the power amplifier screen circuit and thus indicates screen-grid current. In the **mod. position**, the meter is in series with the modulator plate voltage circuit, thus indicating modulator plate current. In the **amp. position**, the meter is in series with the RF amplifier plate voltage circuit, thus indicating plate current of the RF amplifier.  

**Note**

When the meter switch is in the **grid position** the full scale reading of the meter is **40 mils**. In the mod. and amp. positions the full scale reading of the meter is 400 mils.
4. **Audio gain control**  
This control is a potentiometer for use in controlling the audio level to the speech amplifier driver tube (6AQ5) and is placed in the circuit of the speech amplifier between the triode and pentode sections

of the (6U8) dual purpose speech amplifier tube. It **should be in the minimum position when C.W. operation is in use.**

5. **Function switch**  
This switch is composed of two sections and is a six circuit, three position unit performing various functions as described below:—  
In the **C.W. position** it functions to short-circuit the secondary of the modulator transformer and switches the RF amplifier screen voltage to feed direct from the low voltage supply.  
In the **VFO position** it functions to disconnect the screen voltage from the RF amplifier, allowing plate voltage to remain on all other circuits. This position is used to **beat** the VFO signal selected, against the communications receiver for spot frequency operation purposes, etc.  
In the **phone position** it functions to remove the short-circuit across the secondary of the modulator transformer and switches the RF amplifier screen voltage to feed modulated voltage through dropping resistors from the high voltage supply.

#### Note

When it is desired to zero beat the transmitter operating frequency against a received signal, proceed as follows—

- A) With receiver BFO turned **on** tune to zero beat with desired incoming signal (on very strong incoming signals it may not be necessary to use receiver BFO).
  - B) Set function switch on model 5100 transmitter to **VFO position** and adjust VFO to zero beat against the received signal on the communications receiver.
6. **Plate on and off switch**  
This switch functions to complete the circuit (when thrown to the **on** position) of the D.C. voltage which energizes the control relay. Two contacts of the control relay, when closed, completes the primary circuits of the high voltage supply, thus providing the required high voltage D.C. for normal operation.

Reading from left to right, the upper group of con-

trols function as follows:—

### 1. Frequency control

The large knob designated — frequency control — functions through a reduction unit whose ratio is approximately 30 to 1, to control the adjustment of the VFO variable capacitor. The velvet action of this control knob, simultaneously permits the operator to adjust the dial pointer on the frequency selector scale to the desired frequency of operation on any of the six bands.

### 2. Loading control

This control functions to adjust the high capacity variable loading condenser located across the output side of the PI-network circuit of the RF amplifier. Its adjustment determines the degree of loading throughout the tune-up procedures for each of the various bands. Graduations printed on the panel, permits a means of logging the readings for reset purposes.

### 3. Exc. control

This control functions to adjust a variable tuning condenser in the grid circuit of the RF amplifier. In tune-up procedure, it is adjusted to a point where the meter indicates not more than 17 mils. when the meter switch is in the **grid position**.

### 4. Plate tuning

The plate tuning control functions to adjust a variable tuning capacitor located at the input side of the PI-network circuit of the RF amplifier. This variable capacitor is adjusted to a point effecting resonance of the RF amplifier with respect to frequency and

loading conditions as denoted by a minimum dip under loaded conditions as indicated by the meter when the meter switch is in the **amp. position**. The printed graduations on the panel, permits a means of logging the readings for reset purposes.

### 5. Band selector

This knob functions to simultaneously switch the multiplier stages and final amplifier PI-network to the desired frequency output. **This control should not be rotated when the plate switch is in the on position.**

### Microphone connector

This connector unit is of the dual conductor type. One conductor is used for the high side of the microphone, while the remaining conductor is used as the push-to-talk connection. From the front view, the hole on the left side is the microphone connection, the one on the right, the push-to-talk connection.

The push-to-talk connection is a parallel conductor with the plate switch which functions to energize the control relay. Hence, when push-to-talk is used by the operator, the plate switch is left in the **off position**. A microphone with a suitable grip operated push type switch is required to place this control into operation.

### Key Jack

The keying jack is of the closed circuit type, located in the grid circuit of the second buffer stage (6BJ6).

It functions to complete the circuit when not in use under phone operating conditions, while it breaks the grid circuit of the keying tube when the key plug is inserted. The on and off action in C.W. operation is then controlled by action of the key.

## MAINTENANCE

### Removing Chassis from Cabinet

The model 5100 panel is secured to the cabinet by **six** round head screws through the front panel and **two** camlock fasteners on the chassis.

The **two** camlock fasteners are used to firmly secure the chassis to the bottom of the cabinet for shipping purposes. They are located, one on each side of the chassis directly below the front side of the two power transformers, they fasten through the outer lip of the chassis onto the cabinet reinforcement rails on which the chassis slides and rests. See drawing showing cutaway view.

To remove the chassis from the cabinet, first remove the six round head screws on the front panel. These are the screws which run through the wide trim stripe around the outer edge of the front panel. Next, the two camlock fasteners should be loosened with a screw-driver by a one-quarter turn in a counter clockwise direction. After the camlocks are loosened, both hands should be used to reach inside the cabinet gripping each of the two power transformers, one by each hand. Using an upward pull with both hands, to release the camlocks from their seat — the operator should simultaneously pull the chassis with a forward motion until the camlocks are out of their seats and the front panel overlap has been detached from the cabinet.

When placing the chassis back into the cabinet, the camlocks may be left out, if desired.

## TROUBLE SHOOTING

Trouble shooting, parts replacement and repairs of a general nature, should be performed by a qualified technician or an operator with full knowledge of electrical circuits and ability to comprehend the function of each part as well as the ability to detect a defective component responsible for any erratic condition encountered, during the course of voltage and resistance tests and continuity measurements. In most cases of trouble, the difficulty can usually be isolated by means of tests and measurements and the section of the transmitter at fault, when determined, can be quickly and easily removed for repairs without in any way disturbing the other sections of the equipment. Proceed as follows:

1. In cases of interrupted service, first make a check for filament voltage when the A.C. switch is thrown to the **on** position. If tubes do not light, check the fuse and if blown, replace with one of similar value (5 amps.). Do not replace fuse with one of higher value. If fuse blows out when switch is thrown again, check primary circuit of low voltage power supply for a possible short circuit to ground. If primary checks out showing no short to ground, the secondary should be checked for a possible shorted filter capacitor or a defective rectifier tube and other components in the filter circuit.
2. Assuming that filament and low voltage D.C. potentials are normal when the A.C. switch is thrown to the

**on** position, but the fuse blows out when the tune-operate switch is thrown to the operate position, the checks and procedures outlined under paragraph (1) above also apply in these instances.

3. If difficulty persists after checks given under paragraphs 1 and 2, proceed with a voltage check for each pin connection of the chassis connectors to ground and compare meter readings with those given under chassis voltage Table #1. With all power switches in the **off** position — proceed as follows:—
  - A) Disconnect all male cable connectors from the chassis leading to the modulator, buffer-amplifier, VFO and multiplier-RF amplifier.
  - B) With all rectifier and regulator tubes in their respective sockets, throw the A.C. line switch to the **on** position and allow rectifiers to warm up. Next throw the tune-operate switch to the operate position and last, throw the plate switch to the **on** position.
  - C) The voltage reading as measured with a 20,000 ohms per volt volt-ohmmeter, between chassis and each female connector pin **on the chassis** should compare within a tolerance of plus or minus 10% of the voltage given for each respective pin of the various female chassis connectors listed under Table #1.

**TABLE #1  
CHASSIS CONNECTORS - VOLTAGE TABLE  
FUNCTION SWITCH IN PHONE POSITION**

FEMALE CONNECTORS	PINS											
PIN NO'S.	1	2	3	4	5	6	7	8	9	10	11	12
J-3	0	6.3AC	0									
J-4	+165	6.3AC	0	0								
J-5	0	0	0	-60	0	+880	0	0	0	0	6.3AC	6.3AC
J-6	6.3AC	0	-60	6.3AC	0	+300	+900	+900	0	+900	0	0

4. For continuity and resistance measurements utilizing a 20,000 ohm per volt volt-ohmmeter, proceed as follows:—
  - A) With all power switches in the **off** position and A.C. line cord removed from the power source, remove all tubes and **male connector plugs** from the chassis leading to VFO, buffer-amplifier, modulator and multiplier-RF amplifier.
  - B) Resistance measurements between chassis and each female connector pin and tube socket pin connection on the chassis should compare within a tolerance of plus or minus 10% of the values given for each respective value of the various female chassis connectors and socket pin connections under Table #2.

**TABLE #2**  
**FEMALE CHASSIS CONNECTORS & TUBE SOCKETS**  
**RESISTANCE MEASUREMENTS**  
**FUNCTION SWITCH IN PHONE POSITION**

FEMALE  
CHASSIS  
CONNECTORS

PINS

PIN NO'S.	1	2	3	4	5	6	7	8	9	10	11	12
J-3	0	0	∞									
J-4	∞	0	∞	32K								
J-5	∞	∞	∞	3700	—	60K	0	0	0	10K	0	0
J-6	0	∞	3800	0	0	—	60K	60K	∞	∞	0	0
<b>TUBE SOCKETS</b>												
V-14	∞	0	—	∞	∞	—	∞	∞				
V-15	∞	4800	—	∞	0	∞	4800	∞				
V-16	∞	70K	∞	40 Ω	∞	37 Ω	∞	60K				
V-17	∞	70K	∞	40 Ω	∞	37 Ω	∞	60K				
V-18	—	—	∞	—	0	—	—	—				

5. For continuity and resistance measurements of the individual units — VFO, buffer-amplifier, modulator speech amplifier and multiplier RF amplifier, proceed as follows, utilizing a 20,000 ohm per volt volt-ohm-meter—

A) With all power switches in the **off** position and the A.C. line cord removed from the power source, disconnect the male plug connector, (of any of

the units to be tested) from the female counterpart of that respective connector on the chassis and proceed with resistance measurements from each **male** connector plug pin to ground.

B) Resistance measurements between chassis and each plug pin should compare within a tolerance of plus or minus 10% of the values for each of the connector pins listed under Table #3.

**TABLE #3**  
**RESISTANCE MEASUREMENTS WITH TUBES OUT**  
**UNIT MALE PLUG CONNECTORS**

MALE PLUG  
CONNECTORS

PINS

PIN NO'S.	1	2	3	4	5	6	7	8	9	10	11	12
BUFF-AMP-P4	∞	FIL.	∞	∞								
MODULATOR-P6 SPEECH AMP.	FIL.	∞	∞	FIL.	∞	—	∞	∞	∞	∞	0	0
MULTIPLIER-P5 R.F. AMP.	∞	∞	∞	∞	∞	∞	0	0	0	∞	FIL.	FIL.
VFO - P3	0	FIL.	∞									

**Erratic Conditions**

6. Most erratic operating conditions such as, insufficient driving power to R.F. amplifier, modulators, and low D.C. potentials including plate, screen, bias voltages and currents are normally the result of low tube output, hence, it is recommended that all or such tubes as may be suspected of causing trouble resulting in interrupted or erratic operation of a particular section, be replaced or at least tested for compliance to standard performance, before any attempt is made to

seek other sources causing improper operation of any particular section.

7. When tubes have been eliminated as the possible source of any particular difficulty encountered, the schematic diagram of the equipment, provided in this manual, should be used for reference in identifying a particular defective component during the course of voltage and resistance measurements covered under paragraphs 1, 2, 3, 4, and 5 under trouble shooting above.

## TERMINAL CONNECTIONS

### CHASSIS APRON (Rear View)

Figure—

The information given below applies to the terminal connections located on the rear chassis apron of the model 5100 transmitter. Reading from left to right, the terminal connections are as follows:

1. R.F. power output connector
2. A.C. line connections
3. Directly below the A.C. line connections is the fuse holder
4. Terminal strip connections #11 through #1.

### FUNCTIONAL SUMMARY OF REAR CHASSIS APRON TERMINAL CONNECTIONS

The RF power output connector is an SO-239 coaxial fitting. This is the output of the built-in low pass filter. Its counterpart, PL.259 should be used with an appropriate length of 75 ohm coaxial line for power take-off.

The A.C. line connections are the external end of two high-pass type capacitors. The fuse holder is of the screw-in type housing a 5 amp. fuse cartridge, type 3AG.

The terminal strip connection #11 through #1 are as follows:

Terminals #11 and #10 are two of the internal control relay contacts. These contacts which are normally open, may be used in connection with an external antenna change-over relay circuit. When the plate switch is turned on they complete the antenna change-over energizing circuit and vice-versa.

Terminals #9 and #8 are two additional control relay contacts. These contacts which are normally closed, may be used for a communications receiver disabling circuit, choice of which is left to the operator. The internal control relay contacts #8, #9, #10 and #11 covered above have been provided for those who wish to

fully utilize the control features built into the model 5100 transmitter.

In addition to the normal multiband performance herein described the model 5100 transmitter can also be utilized to provide the following:

1. Unmodulated R.F. power output for driving a higher powered final amplifier.
2. 75 watts of audio power for driving a higher powered modulator, less the R.F. driving power. Impedance value of audio output is 500 ohms.
3. Unmodulated R.F. power output in combination with 75 watts of audio power output through 500 ohms for the dual purpose of driving a higher powered final amplifier and modulator unit.

To obtain unmodulated R.F. power output for driving purposes indicated under (1) above, turn the **function switch** on the front panel to **C.W. position**. Connect a suitable coax line from R.F. output power connector to input stage of high powered final. Proceed as directed under operating instructions.

To obtain 75 watts of audio power output less the R.F. driving power indicated under (2) above, turn **function switch** on front panel to **phone position**. Open jumper connections between terminals 7 & 6, 4 & 3 on rear terminal strip. Connect a suitable 500 ohm line between terminals 7 & 5 to input of high powered modulator.

To obtain the combination of unmodulated R.F. and audio driving power as indicated under (3) above, turn **function switch** on front panel to **C.W. position**. Open jumper connections 7 & 6, 4 & 3 on rear terminal strip. Connect a suitable coax line from R.F. output power connector to input stage of high powered R.F. amplifier. Connect a suitable 500 ohm line between terminals 7 and 5 to input of high powered modulator unit.

Terminals #2 and #1 are the extension of the push to talk circuit provided on the front panel through the microphone connector. These terminal connectors may be used for remote operation purposes as individually required by each operator. Terminal #1 also serves as the common chassis ground. It is highly recommended to tie #1 terminal down to a good ground through heavy copper wire or braid.

## ALIGNMENT AND TUNING PROCEDURE

### MULTIPLIER R. F. AMPLIFIER UNIT

1. Remove multiplier R.F. amplifier unit from main chassis by disconnecting power cable plug (#P 5), remove four mounting screws, all knobs and coax output cable.
2. Provide a suitable extension power cable with appropriate plug and jack connectors to match P#5, and J#5 permitting operation of unit external to chassis also a suitable extension coax line to match P#2 and J#2.
3. Set function switch on VFO position — **This is important.**
4. Place the test leads of a 20,000 ohm per volt, volt-ohmmeter across the R.F. amplifier grid resistor R 23, value 22K, located on back panel of RF amplifier unit. Set instrument scale to 250 volt D.C. and observe proper polarity.
5. Adjust excitation control — variable capacitor C 36 until its rotor plates are enmeshed approximately 60%. The unit is now prepared for alignment for each individual band and the next steps for each band are as follows—
6. **80 meter band**
  - (A) Set band selector switch on 80 meter position.
  - (B) Set VFO frequency to 3750 K.C.
  - (C) Adjust core screw of L-6 to obtain maximum reading on meter which has been placed across R 23.
7. **40 meter band**
  - (A) Set band selector switch on 40 meter position.
  - (B) Set VFO frequency to 7200 K.C.
  - (C) Adjust core screw of L-7 to obtain maximum reading on meter.

## 8. 20 meter band

- (A) Set band selector switch on a 20 meter position.
- (B) Set VFO frequency to 14,200 K.C.
- (C) Adjust core screw of L-8 to obtain maximum reading on meter.

## 9. 15 meter band

- (A) Set band selector switch on 15 meter position.
- (B) Set VFO frequency to 21,150 K.C.
- (C) Adjust core screw of L-9 to obtain maximum reading on meter.

## 10. 10 meter band

- (A) Set band selector switch on 10 meter position.
- (B) Set VFO frequency to 28,800 K.C.
- (C) Adjust core screw of L-10 to obtain maximum reading on meter.
- (D) Adjust capacitor trimmer C-31 which is across the grid of V-7 for maximum reading on meter. The C-31 capacitor trimmer is located on the underside of the multiplier RF unit.

## 11. 11 meter band

- (A) Set band selector switch on 11 meter position.
- (B) Set VFO frequency to 27,120 K.C.
- (C) Adjust capacitor trimmer C-38 accessible through hole on left side of multiplier RF amplifier panel, for maximum reading on meter.
- (D) Adjust capacitor trimmer C-33 accessible through hole on right side of multiplier RF amplifier panel, for maximum reading on meter.
- (E) Repeat adjustments of C-38 and C-33 as required to obtain maximum reading on meter.

The multiplier RF amplifier unit is now completely aligned and it can be placed back in its position on the main chassis, etc.

Detailed instructions covering the dial cord replacement is given in a drawing elsewhere in this manual.

## ANTENNA SYSTEMS

The Model 5100 may be used with a variety of antenna systems, however, since it is factory equipped with a low pass filter whose characteristic output impedance is 75 ohms, the output power should be arranged to feed into a load of equal impedance. This does not mean that the operator is limited to use an antenna feed line system with an impedance of 75 ohms only, on the contrary, several line impedance values can be utilized effectively, the choice of which is left entirely to the operator and local conditions affecting the installations, etc.

Several typical examples of antennas and feed line systems which can be successfully used with the 5100 transmitter are illustrated under figures (1A) (2A) (3A) (4A) (5A) (6A).

### SUMMARY OF VARIOUS ANTENNA SYSTEMS

#### Fig. (1A) SINGLE BAND HALF WAVE FOLDED DIPOLE ANTENNA

This diagram illustrates the Model 5100 transmitter connected to a half wave folded dipole antenna. The impedance match from 75 to 300 ohms

## ALIGNMENT AND TUNING PROCEDURE

### VFO UNIT

The VFO unit as shipped from the factory is completely aligned. Realignment is a matter which only becomes necessary in those cases where the oscillator tube needs to be changed or the dial cord requires replacement.

In such cases where the oscillator tube has been changed, the procedure for alignment of this unit is as follows:

1. A signal source of exactly 3.6 mc. is to be tuned in on a communications receiver.
2. After the VFO unit has been allowed to warm up, turn frequency control knob and set pointer on scale to read the exact frequency used as pointed out under paragraph #1 above.
3. The last step required is to adjust the small trimmer capacitor (C3) located on the top of the VFO chassis until the VFO frequency as varied by the adjustment of (C3) zero beats exactly with the standard as monitored on the communications receiver.

This completes the alignment procedure required in cases of tube replacements.

When the VFO unit requires realignment due to a broken dial cord, the procedure is as follows:

1. After the dial has been restrung with a new cord, tune in a signal of known frequency on the communications receiver. The known frequency in this case can also be same as used above, 3.6 mcs.
2. The next step is to turn the frequency control knob until the VFO produces a zero beat against the signal tuned in on the communications receiver.
3. The last step is to move the dial pointer assembly without in any way altering the zero beat signal on the communications receiver, until the pointer reads 3.6 mcs. on the scale.

and the transformation from unbalance to balance is effected through the medium of the B&W multi-band balun unit assembly made up with two B&W type #3975 bifilar wound coils.

Several of these antennas may be used for such applications where local conditions provide space and the operator chooses to use a separate antenna for each band of operation.

Where space and local facilities do not provide for high gain type antennas for 20-15 and 10 meters, these fundamental types will be found to give satisfactory results.

#### Fig. (2A) MULTIBAND ANTENNA FOR 80-40-20 and 10 METERS

A multi-band antenna of this type provides the operator with a radiating system for each of the bands listed above. Perhaps not as effective as separate half wave antennas due to orientation restrictions, it can be considered a compromise where space limitations and other local conditions would normally confine operations to one or two bands only.

Considering that no switching or tuning is required, this compromise antenna system provides a means of quick changeover from one band to another for those who wish to fully utilize multi-band operation with the Model 5100 transmitter.

#### Fig. (3A) BEAM ANTENNAS

This illustration shows the method of effectively connecting and matching the output of the Model 5100 to a beam antenna, through use of a B&W beam matching balun. 75 ohm coaxial line is used from the output of the Model 5100 to the beam matching balun which mounts at the beam. Instructions provided with the beam baluns covers installation instruction details.

Applicable baluns for the 20-15 and 10 meter bands are as follows:

- 20 Meter — B&W #702
- 15 Meter — B&W #701
- 10 Meter — B&W #700

#### Fig. (4A) HALF WAVE SPLIT DIPOLE ANTENNA

This illustration shows a half split dipole antenna. Its performance in every respect is similar to the folded dipole, illustrated in Fig. 1A. However, the feed line system is of the 75 ohm twin parallel wire type. The #3975 type balun in this case is wired accordingly as covered by the instruction sheets packed with these balun units. Like the folded dipole, several of these antennas can be arranged for quick switching when operation on another band is desired.

#### Fig. (5A & 6A) HALF WAVE SPLIT DIPOLE AND END FED ZEPP USING OPEN WIRE FEED LINE SYSTEM

These antennas from the operational viewpoint are basically similar to the other half wave types shown under Figs. 1A and 4A. Transformation from unbalance to balance is accomplished through the medium of the antenna coupler circuit.

The antenna coupler essentially consists of a B&W antenna coupler coil with a fixed link and a B&W JCX100E variable split stator condenser equipped with a jack bar and mounting brackets, providing a compact assembly without leads.

Feed line impedance matching is obtained by tapping of the open wire feed line at appropriate points across the antenna coupler coil, while the proper load for the transmitter is achieved by a combination of adjusting the transmitter loading and plate tuning controls and the adjustment of the antenna tuning condenser.

While this system is extremely flexible from the standpoint of its ability to match and function well with a varied collection of open wire feed line systems, the only objectional factor disliked by a few operators is the extra tuning control. However, in spite of such ob-

jections, it can be considered as the only simple and practical solution to the problem of matching an assortment of different antennas with various types of feed line systems of different impedance values.

Although this antenna coupler and matching system has been shown here as used with half wave antennas, its usefulness can also be extended in other applications with longer antennas, such as the odd or even half wave multiple types as well as the rhombic and "V" type high gain antennas, in fact, any antenna system where a resonant or non-resonant feed line system can be adapted.

A suggested method of adjusting the antenna coupler when used with the PI-network output of the B&W Model 5100 transmitter is given below:

1. With the **tune operate switch** in the **tune position**, adjust the loading control of the Model 5100 until the plates of the loading capacitor are fully meshed. The scale reading as indicated by the pointer on the knob will be "0".
2. Refer to Figs. 5A & 6A and short circuit C1 then adjust plate tuning control on Model 5100 transmitter for minimum dip as indicated by the meter, when **meter switch** is in **amp. position**.
3. Remove short circuit and adjust C1 for maximum loading.
4. Tap feeders on L1, starting at extreme outer ends of coil. Locate correct tap points on coupler coil, by moving taps towards center, that gives maximum loading, corresponding with reading of C1 under paragraph #3 above.
5. Throw **tune operate switch** to the **operate position** and proceed with adjustment of loading control on Model 5100 until the final is loaded to maximum and repeat the minimum dip of the plate tuning capacitor as explained under paragraph "2" above. At this point, if the setting of C1 is same as noted under paragraph #3 above, the standing wave ratio can be considered to be satisfactory while on the other hand if the setting of C1 indicates an increase in capacity for proper load conditions, the line is inductively reactive or capacitively reactive when the setting of C1 at this condition, shows a decrease in capacity.
6. The correction of either inductive or capacitive reactance in cases where the operator desires to obtain a minimum SWR, is best accomplished through use of an SWR indicator placed in the coax line between the transmitter output and the antenna coupler. Repeating the matching and tuning process explained above, until a minimum SWR is obtained.

For other type antennas not covered herein, reference to the ARRL antenna handbook provides a good source of information.



# CHASSIS-UNDERSIDE VIEW

INSIDE SHIELD COVER

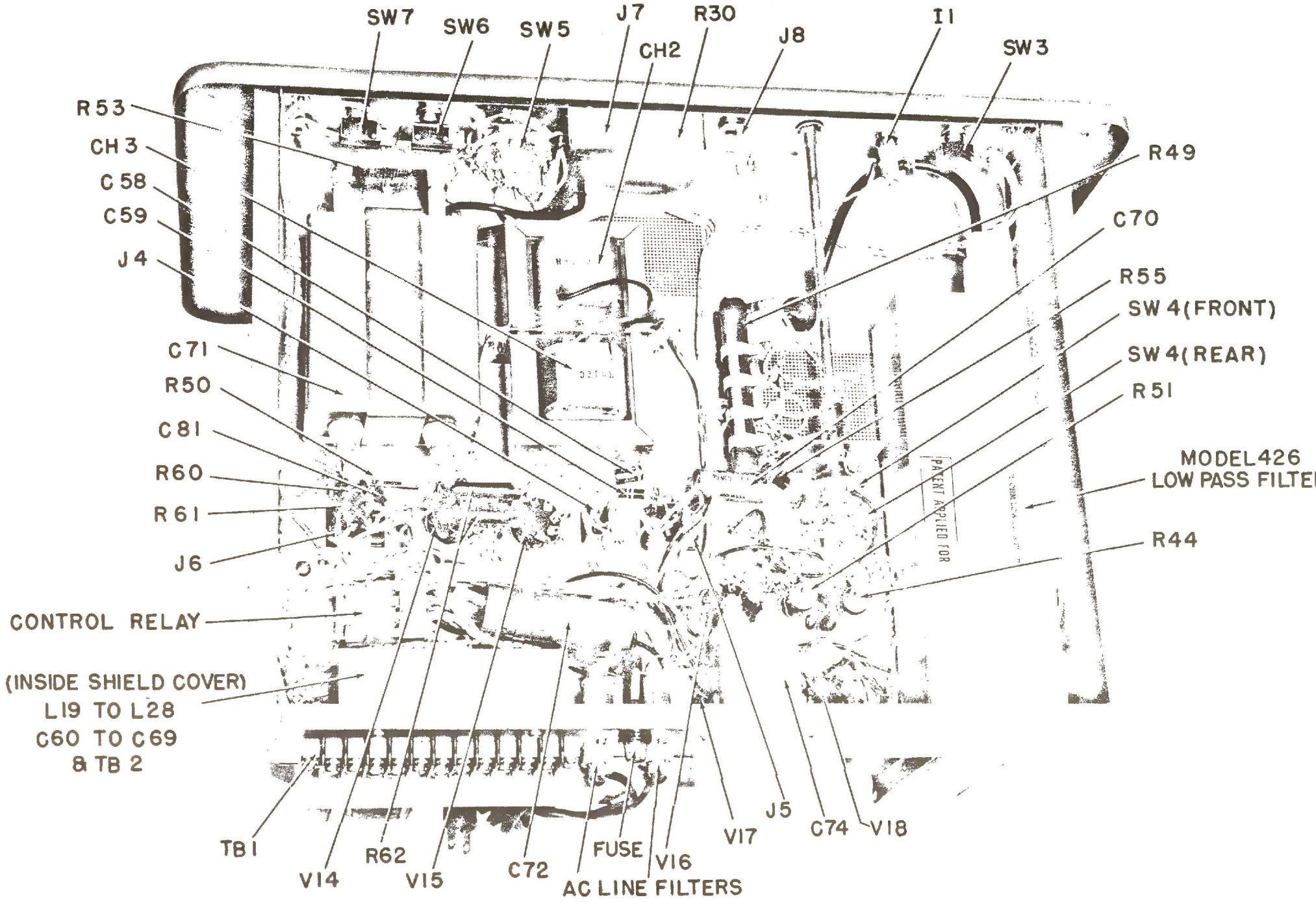

# INSTRUCTIONS FOR STRINGING VFO DIAL ASSEMBLY

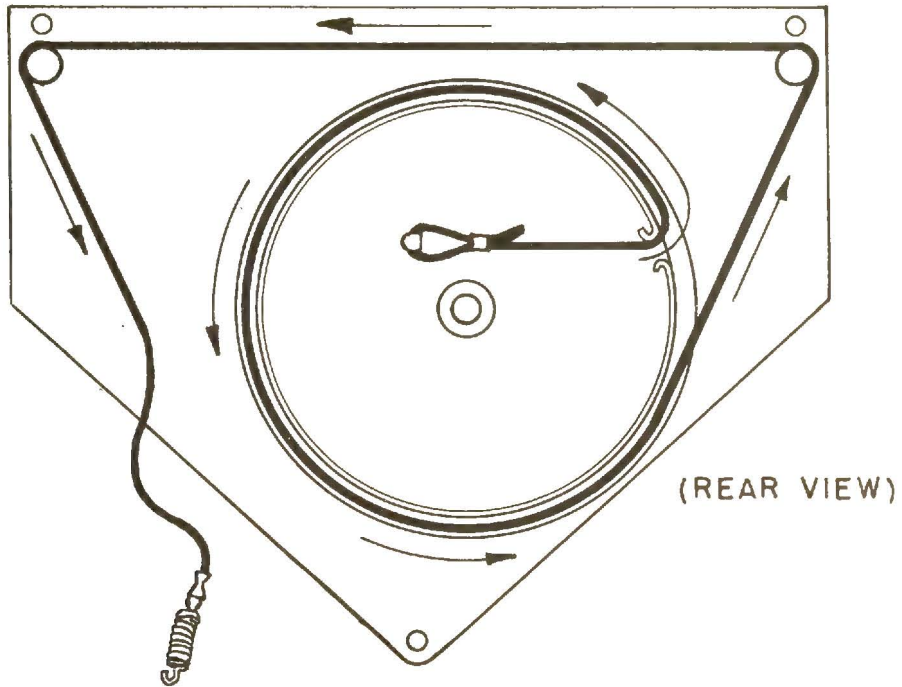

## STEP 1

ROTATE LARGE PULLEY TO POSITION SLOT AS SHOWN. USE A HOOK-ENDED TOOL TO CATCH LOOP OF CORD IN PROJECTION ON TOP OF PULLEY.

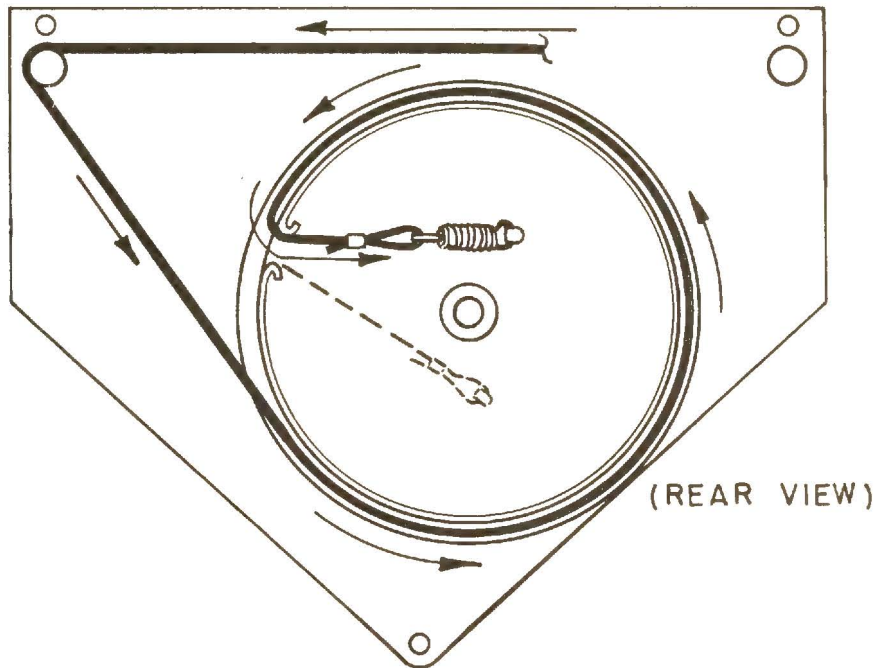

## STEP 2

ROTATE LARGE PULLEY TO POSITION SHOWN. USE HOOK-ENDED TOOL TO SECURE SPRING LOOP IN TOP PROJECTION.

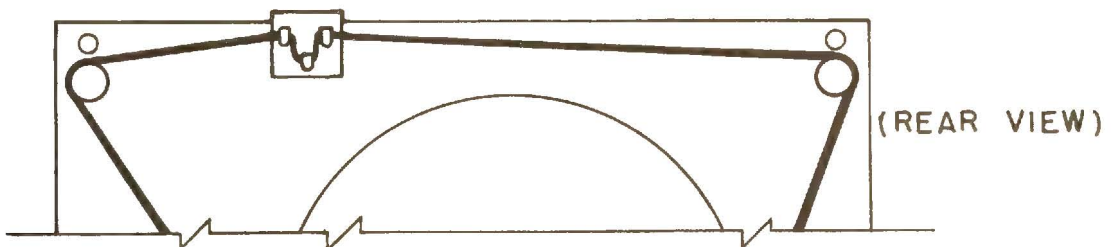

## STEP 3

ROTATE LARGE PULLEY TO THE MID-POINT OF ITS ROTATION AND INSTALL POINTER AS SHOWN.

\*  
V17  
5R4-GY

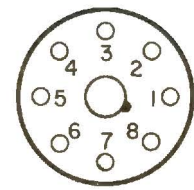

\*  
V18  
5V4

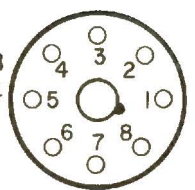

\*  
V16  
5R4-GY

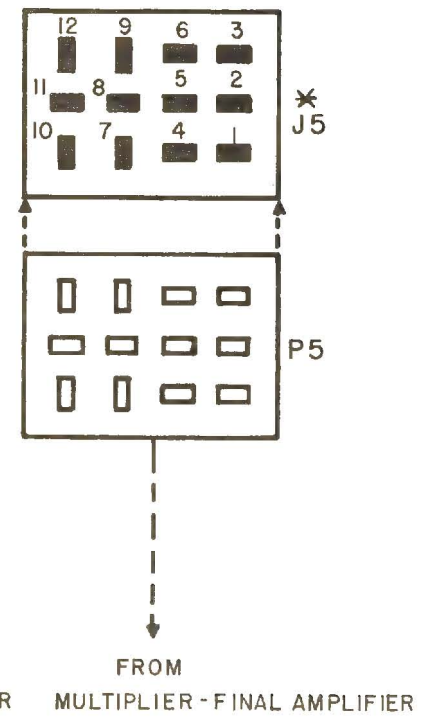
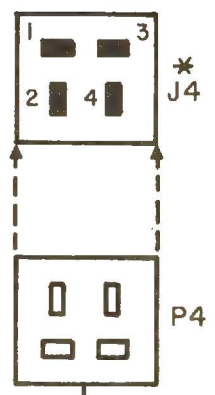
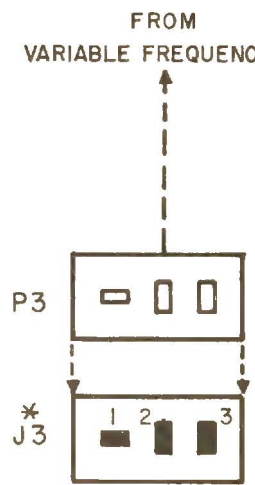
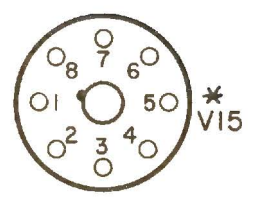
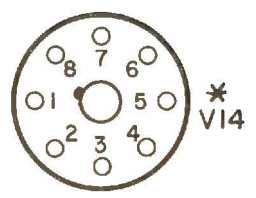
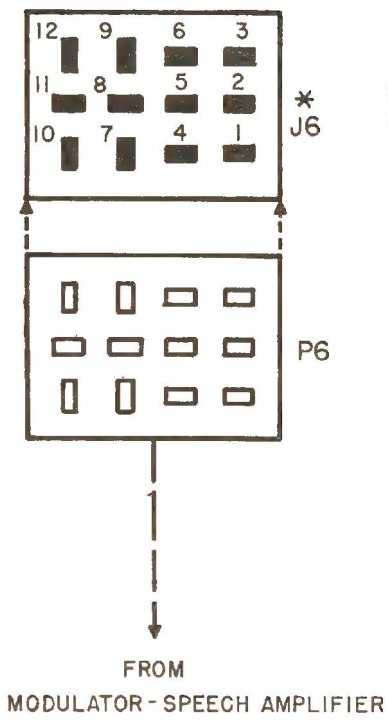
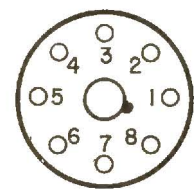

\* TUBE SOCKETS AND JACKS ARE LOCATED IN POWER SUPPLY CHASSIS

DOTTED LINES SHOW CONNECTIONS  
FOR OBTAINING A.C. POWER FOR ENERGIZING  
AND CONTROLLING EXTERNAL ANTENNA  
CHANGE-OVER RELAY.

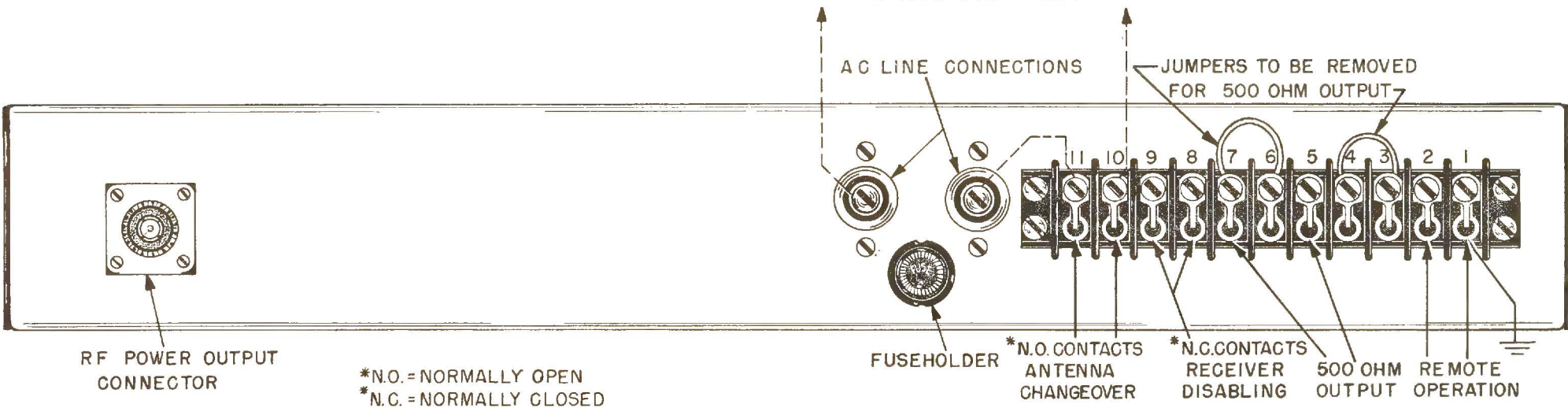

FIGURE - CHASSIS APRON (REAR VIEW)

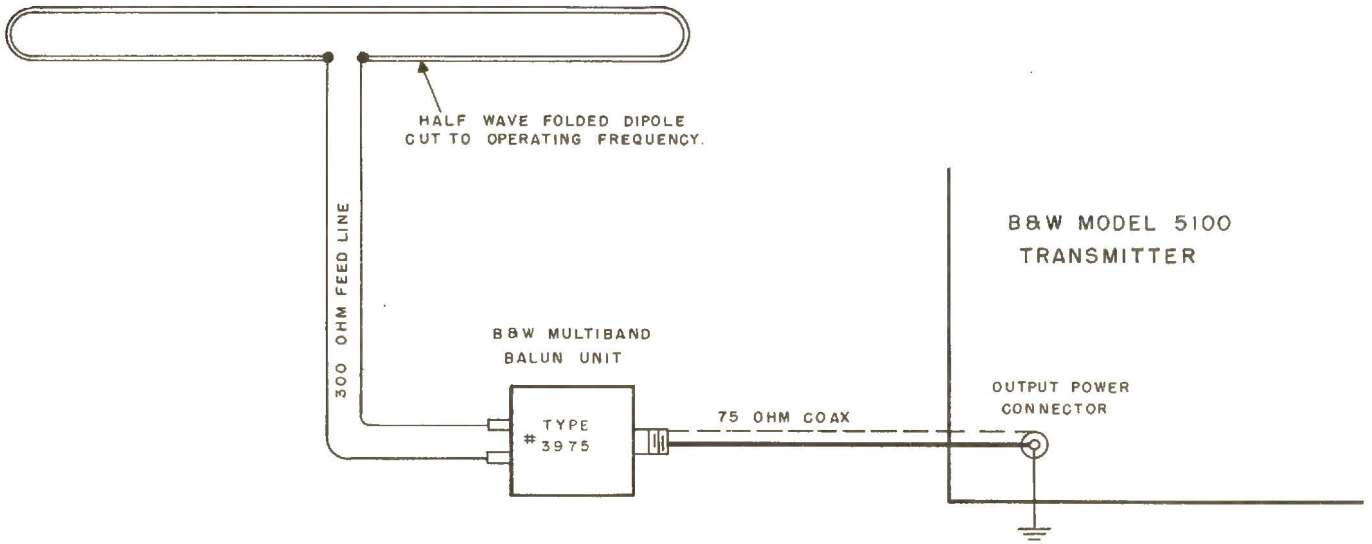

FIGURE 1A- SINGLE BAND ANTENNA

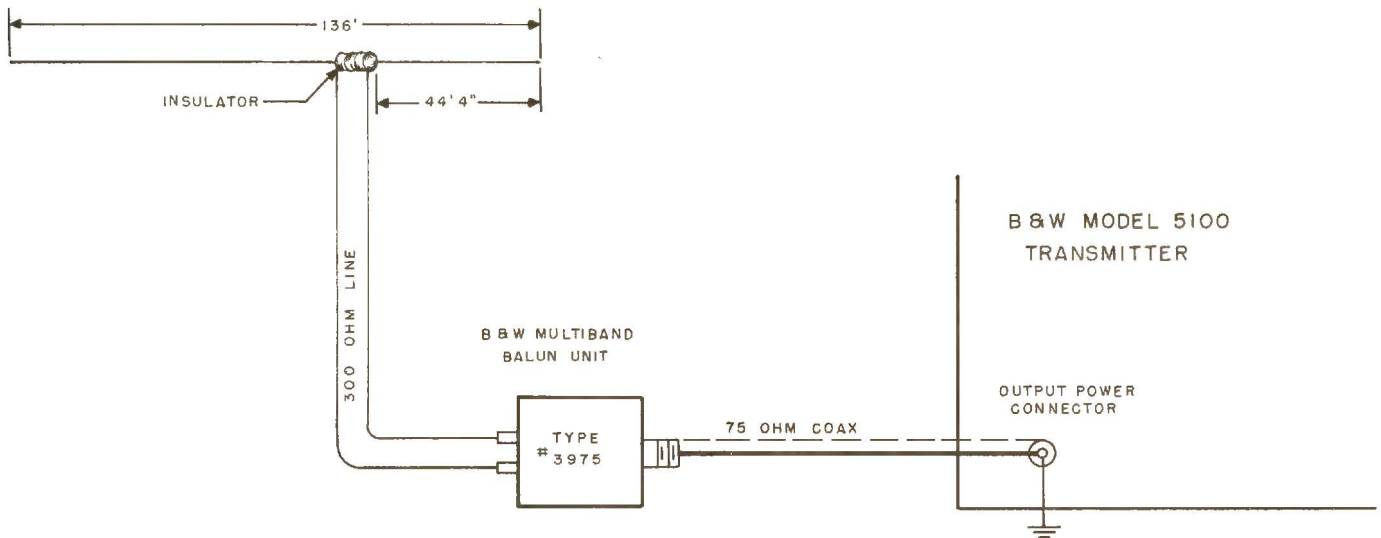

FIGURE 2A - MULTIBAND ANTENNA COVERS, 80, 40, 20 AND 10 METERS.

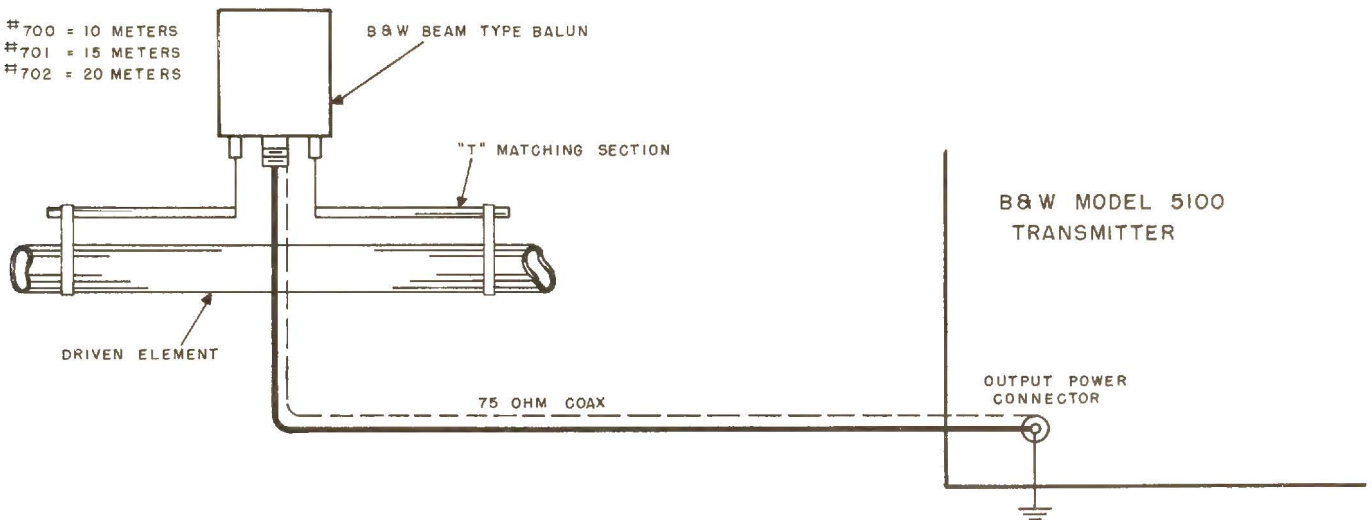

FIGURE 3A- BEAM ANTENNAS FOR EITHER 10, 15 OR 20 METERS.

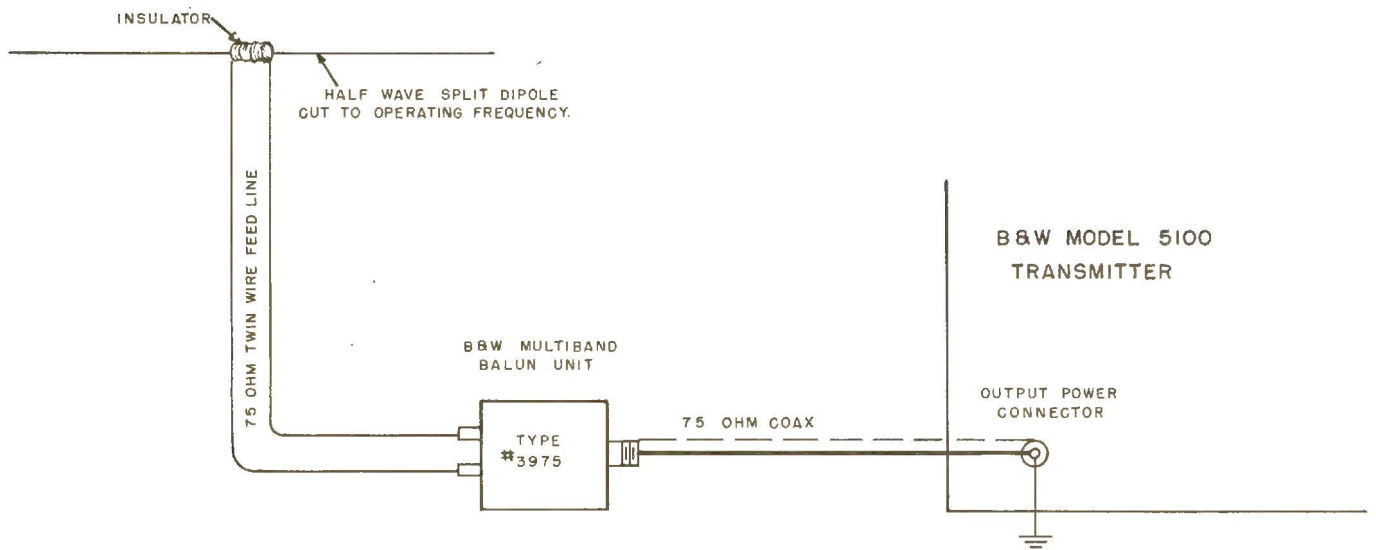

FIGURE 4A- SINGLE BAND ANTENNA

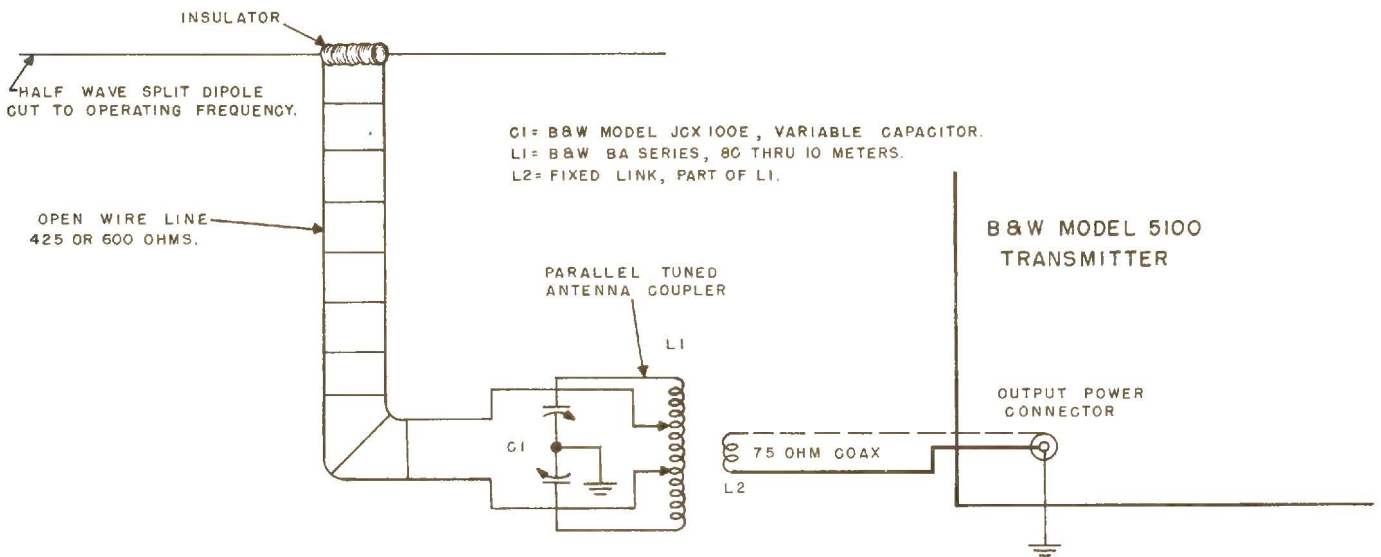

FIGURE 5A- CENTER FED, HALF WAVE SPLIT DIPOLE.

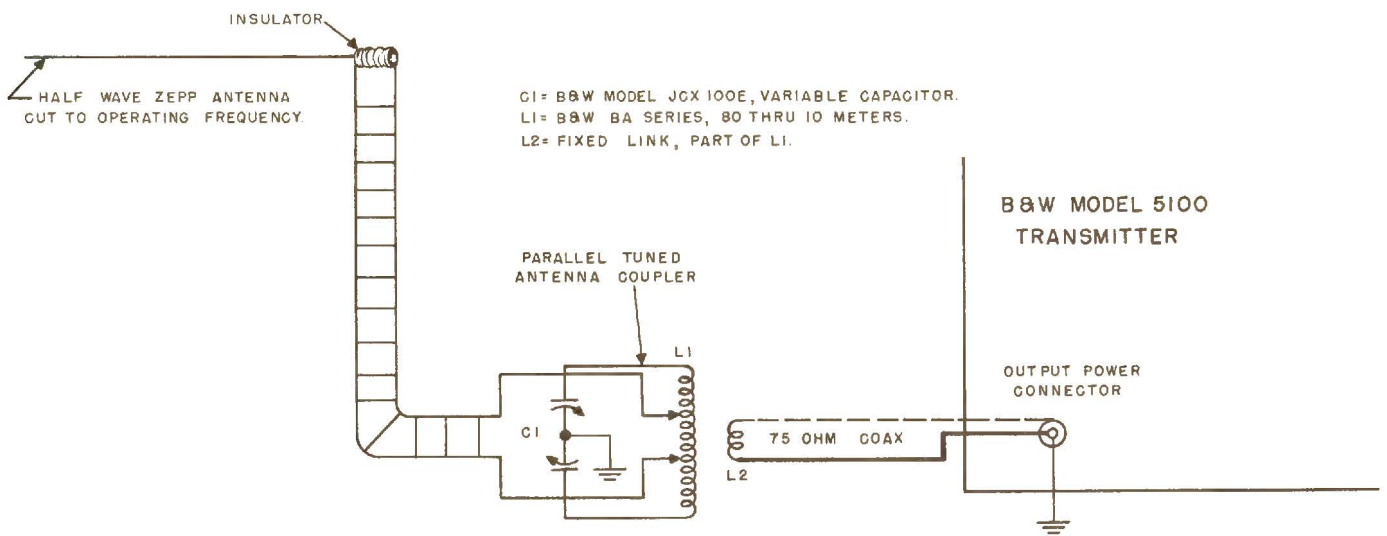

FIGURE 6A- END FED, HALF WAVE ZEPP.

# PARTS LIST - MODEL 5100 TRANSMITTER

Circuit Symbol	Sub. Assy. Location	Description	B & W Part #	Circuit Symbol	Sub. Assy. Location	Description	B & W Part #
C15	Buffer Xtal Osc.	Capacitor Ceramic Tubular 50 MMF $\pm 5$ MMF —750 Neg. Temp. Coeff.	T-616	C62	Power Supply C.	Capacitor Disc Ceramicon .001 MFD 1500 V.	T-679
C16	Buffer Xtal Osc.	Capacitor Disc .001 MF	T-509	C63	Power Supply C.	Capacitor Disc Ceramicon .001 MFD 1500 V.	T-679
C17	Buffer Xtal Osc.	Capacitor Disc .001 MF	T-509	C64	Power Supply C.	Capacitor Disc Ceramicon .001 MFD 1500 V.	T-679
C18	Buffer Xtal Osc.	Capacitor Ceramic Tubular 95 MMF $\pm 9.5$ MMF —750 Neg. Temp. Coeff.	T-643	C65	Power Supply C.	Capacitor Disc Ceramicon .001 MFD 1500 V.	T-679
C19	Buffer Xtal Osc.	Capacitor Ceramic Tubular 20 MMF $\pm 2$ MMF —750 Neg. Temp. Coeff.	T-644	C66	Power Supply C.	Capacitor Disc Ceramicon .001 MFD 1500 V.	T-679
C20	Buffer Xtal Osc.	Capacitor Disc .001 MF	T-509	C67	Power Supply C.	Capacitor Disc Ceramicon .001 MFD 1500 V.	T-679
C75	Buffer Xtal Osc.	Capacitor Disc .001 MF	T-509	C68	Power Supply C.	Capacitor Disc Ceramicon .001 MFD 1500 V.	T-679
C76	Buffer Xtal Osc.	Capacitor Disc .001 MF	T-509	C69	Power Supply C.	Capacitor Disc Ceramicon .001 MFD 1500 V.	T-679
C21	Multiplier F. A.	Capacitor Disc .001 MF	T-509	C70	Power Supply C.	Capacitor Electrolytic 20 MFD 150 V.	T-578
C22	Multiplier F. A.	Capacitor Disc .001 MF	T-509	C71	Power Supply C.	Cap. oil filled paper 10 MFD 1000 V. with mtg. strap for inv. mtg.	T-579
C23	Multiplier F. A.	Capacitor Fixed Ceramic CC21UJ430J	T-621	C72	Power Supply C.	Dual Elect. Capacitor Aluminum case 20-20 MFD 450V. with mtg. strap	T-581
C24	Multiplier F. A.	Capacitor Mica 100 MMF 1500 VDCW $\pm 20\%$	T-501	C74	Power Supply C.	Capacitor oil filled paper .25 MFD 2000 volts with mtg. strap for upright mtg.	T-580
C25	Multiplier F. A.	Capacitor Disc .001 MF	T-509	C81	Power Supply C.	Capacitor Disc .001 MF	T-509
C26	Multiplier F. A.	Capacitor Disc .001 MF	T-509	SW1	Buffer Xtal Osc.	Toggle Switch—S.P.S.T.	T-537
C27	Multiplier F. A.	Capacitor Mica 100 MMF 1500 VDCW $\pm 20\%$	T-501	SW2	Multiplier F. A.	Switch 6 position 5 wafer ceramic	T-556
C28	Multiplier F. A.	Capacitor Fixed Ceramic CC26UJ750J	T-622	SW8	Multiplier F. A.	Switch 6 position 1 wafer with detent & shaft $\frac{3}{8}$ " bushing 1- $\frac{5}{8}$ " shaft lgth.	T-555
C29	Multiplier F. A.	Capacitor Disc .001 MF	T-509	SW3	Power Supply C.	Bat Handle toggle switches 3A. 125V. S.P.S.T.	T-592
C30	Multiplier F. A.	Capacitor Disc .001 MF	T-507	SW4	Power Supply C.	Selector Switch non-shorting 3 pole 2 section	T-594
C31	Multiplier F. A.	Trimmer Erie TS-2A-N-500-7-45	S-123	SW5	Power Supply C.	Selector Switch non-shorting 3 pole 1 section	T-595
C32	Multiplier F. A.	Capacitor Mica 100 MMF 1500 VDCW $\pm 20\%$	T-501	SW6	Power Supply C.	Bat Handle toggle switches 3A. 125 V. S.P.S.T.	T-592
C33	Multiplier F. A.	Trimmer Erie TS-2A-N-500-7-45	S-123	SW7	Power Supply C.	Bat Handle toggle switches 3A. 125 V. S.P.S.T.	T-592
C34	Multiplier F. A.	Capacitor Disc .001 MF	T-509	P1	VFO	Phono Plug	T-288-1
C35	Multiplier F. A.	Capacitor Disc .001 MF	T-509	P3	VFO	Cable Plug (3)	T-667
C36	Multiplier F. A.	Capacitor Variable Air 28 MMF APC type	T-SP-160	P2	Buffer Xtal Osc.	Phone Plug (Jumper between Buffer & Multiplier)	T-288-1
C37	Multiplier F. A.	Capacitor Mica 100 MMF 1500 VDCW $\pm 20\%$	T-501	P9	Buffer Xtal Osc.	Phone Plug (Jumper between Buffer & Multiplier)	T-288-1
C38	Multiplier F. A.	Trimmer Erie TS-2A-N-500-7-45	S-123	P4	Buffer Xtal Osc.	Cable Plug (4)	T-666
C39	Multiplier F. A.	Capacitor Fixed Mica VCM20B 102M Elmenco 1000 V.	T-SP-164	P5	Multiplier F. A.	12 pin Jones Plug	T-633
C40	Multiplier F. A.	Capacitor Fixed Mica .002 MMF 2500 VDC - CM50A202J	T-SP-162	P6	Modulator S.A.	12 pin Jones Plug	T-633
C41	Multiplier F. A.	Capacitor Variable Air 325 MMF	T-SP-163	J1	Buffer Xtal Osc.	Phono Socket	T-288
C42(A&B)	Multiplier F. A.	Capacitor Variable Dual 530 MMF	T-656	J9	Buffer Xtal. Osc.	Phono Socket	T-288
C44	Multiplier F. A.	Capacitor Fixed Mica .0051 MF 2500 VDC CM50A512 J	T-SP-161	J2	Multiplier F.A.	Input Jack	T-288
C45	Multiplier F. A.	Capacitor Fixed Mica VCM20B 102 M 1000 Volt	T-SP-164	J3	Power Supply C.	3 terminal Jones Socket	T-674
C46	Modulator S. A.	Capacitor Disc .001 MF	T-509	J4	Power Supply C.	4 terminal Jones Socket	T-591
C47	Modulator S. A.	Capacitor Mica 50 MMFD	T-614	J5	Power Supply C.	12 terminal Jones Connector	T-590
C48	Modulator S. A.	Capacitor Disc .001 MF	T-509	J6	Power Supply C.	12 terminal Jones Connector	T-590
C49A	Modulator S. A.	Capacitor Electrolytic 10-10 MFD 500V.	T-577	J8	Power Supply C.	Jack, Key	T-593
C49B	Modulator S. A.	Capacitor Electrolytic 10-10 MFD 500V.	T-577	J7	Modulator S. A.	2 contact locknut receptacle Amphenol 80-PC2F	T-611
C50	Modulator S. A.	Tubular Paper Capacitor .1 MFD 400V.	T-617	L1	VFO	Oscillator Coil Assy.	T-715
C51	Modulator S. A.	Capacitor Disc .001 MF	T-509	L2	VFO	Filament Choke - RFC	T-359
C53	Modulator S. A.	Capacitor Electrolytic Single 10MF/25V	T-615	L3	VFO	Plate Choke	T-712
C54	Modulator S. A.	Capacitor Disc .001 MF	T-509	L4	Buffer Xtal Osc.	Grid Choke	T-712
C55	Modulator S. A.	Capacitor Disc .001 MF	T-509	L5	Buffer Xtal Osc.	Screen Choke	T-713
C56	Modulator S. A.	Capacitor Disc .001 MF	T-509	L6	Multiplier F.A.	80 M 37 MH Coil Assy.	5100-2
C57	Modulator S. A.	Capacitor Disc .001 MF	T-509	L7	Multiplier F.A.	40 M 9.5 MH Coil Assy.	5100-3
C58	Power Supply C.	Capacitor Tubular Paper .1 MFD 200V.	T-673	L8	Multiplier F.A.	20 M 2.5 MH Coil Assy.	5100-4
C59	Power Supply C.	Capacitor Disc Ceramic .01 MFD 500 V.	T-607	L9	Multiplier F.A.	15 M 2 MH Coil Assy.	5100-1
C60	Power Supply C.	Capacitor Disc Ceramicon .001 MFD 1500 V.	T-679	L10	Multiplier F.A.	10 M .68 MH Coil Assy.	5100-5
C61	Power Supply C.	Capacitor Disc Ceramicon .001 MFD 1500 V.	T-679	L11	Multiplier F.A.	R. F. Choke Screen	T-711

# PARTS LIST - MODEL 5100 TRANSMITTER

Circuit Symbol	Sub. Assy. Location	Description	B & W Part #	Circuit Symbol	Sub. Assy. Location	Description	B & W Part #
R1	VFO	Resistor 100,000 ohms 1/2 W. 5%	R-22	R38	Modulator S. A.	Resistor Composition 1000 ohm 1/2 W. 10%	R-65
R2	VFO	Resistor 560 ohms 1/2 W. 10%	T-244	R39	Modulator S. A.	Resistor Composition 1000 ohm 1/2 W. 10%	R-65
R3	VFO	Resistor 10,000 ohms 1/2 W. 5%	R-16	R40	Modulator S. A.	Resistor Carbon 100 ohm 1 W. 10%	R-58
R4	Buffer Xtal Osc.	Resistor Composition 150 ohm 1/2 W. 10%	R-62	R41	Modulator S. A.	Resistor Carbon 100 ohm 1 W. 10%	R-58
R5	Buffer Xtal Osc.	Resistor Composition 5600 ohm 1/2 W. 10%	R-63	R42	Modulator S. A.	Resistor 5000 ohm 10 watt 20% wire wound	T-113
R6	Buffer Xtal Osc.	Resistor Composition 220 ohm 1/2 W. 20%	R-64	R43	Modulator S. A.	Resistor wire wound 4.7 ohm 1 W. ±5%	R-70
R7	Buffer Xtal Osc.	Resistor 100,000 ohms 1/2 W. 5%	R-22	R60	Modulator S. A.	Resistor Composition 100,000 ohm 2 W. 10%	R-71
R8	Buffer Xtal Osc.	Resistor Composition 150 ohms 1/2 W. 10%	R-62	R61	Modulator S. A.	Resistor Composition 100,000 ohm 2 W. 10%	R-71
R9	Buffer Xtal Osc.	Resistor Composition 1000 ohms 1/2 W. 10%	R-65	R63	Modulator S. A.	Resistor 10,000 ohm 1/2 W. 20%	R-102
R10	Buffer Xtal Osc.	Resistor Composition 5600 ohms 1/2 W. 10%	R-63	R44	Power Supply C.	Resistor, wire wound, adj. 25,000 ohm 25 watts with one adj. lug 20%	T-584
R54	Buffer Xtal Osc.	Resistor Composition 220 ohm 1/2 W. 20%	R-64	R45	Power Supply C.	Meter Shunt to read full scale 40 MA D. C.	T-600
R11	Multiplier F. A.	Resistor Carbon 47,000 ohm 1 W. 10%	R-56	R46	Power Supply C.	Meter Shunt to read full scale 400 MA D. C.	T-601
R12	Multiplier F.A.	Resistor Carbon 560 ohm 2 W. 10%	R-57	R47	Power Supply C.	Meter Shunt to read full scale 400 MA D. C.	T-601
R13	Multiplier F.A.	Resistor Carbon 100 ohm 1 W. 10%	R-58	R48	Power Supply C.	Resistor Composition 33,000 ohm 1/2 W. ±10% insulated	T-598
R14	Multiplier F.A.	Resistor Carbon 2200 ohm 2 W. 10%	R-81	R49	Power Supply C.	Resistor wire wound adj. 20,000 ohms 50 watt with 2 mounting brackets and 4 adj. lugs	T-582
R15	Multiplier F.A.	Resistor Carbon 100 ohm 1 W. 10%	R-58	R50	Power Supply C.	Resistor wire wound 60,000 ohm 10 W. 20%	T-587
R16	Multiplier F.A.	Resistor Carbon 47,000 ohm 1 W. 10%	R-56	R51	Power Supply C.	Resistor wire wound adj. 2,000 ohm 25 watts with one adj. lug	T-583
R17	Multiplier F.A.	Resistor Carbon 1,000 ohm 2 W. 10%	R-80	R52	Power Supply C.	Resistor Composition 100,000 ohm 2 W. ±10%	R-71
R18	Multiplier F.A.	Resistor Carbon 100 ohm 1 W. 10%	R-58	R53	Power Supply C.	Resistor wire wound special heater	T-588
R19	Multiplier F.A.	Resistor Carbon 47,000 ohm 1 W. 10%	R-56	R55	Power Supply C.	Resistor Composition 100,000 ohm 2 W. ±10%	R-71
R20	Multiplier F.A.	Resistor Carbon 1,000 ohm 2 W. 10%	R-80	R59	Power Supply C.	Resistor Carbon 22,000 ohm 1 W. 10%	R-59
R21	Multiplier F.A.	Resistor Carbon 100 ohm 1 W. 10%	R-58	R62	Power Supply C.	Resistor 2,000 ohm 10 W. 10% Ohmite	R-101
R22	Multiplier F.A.	Resistor 18,000 ohm 2 W. 10%	R-82	C1	VFO	Cap. Ceramic Tubular 100 MMF ±1% Zero-Temp. uninsulated type	T-727
R23	Multiplier F.A.	Resistor Carbon 22,000 ohm 1 W. 10%	R-59	C2	VFO	Capacitor Variable	T-620
R24	Multiplier F.A.	Resistor Carbon 47 ohm 2 W. 10%	R-60	C3	VFO	Capacitor 25 MMF APC	T-314
R25	Multiplier F.A.	Resistor Carbon 100 ohm 1 W. 10%	R-58	C4	VFO	Capacitor Ceramic Tubular 100 MMF ± 10 MMF Zero Temp. Coeff.	T-646
R26	Multiplier F.A.	Resistor Carbon 100 ohm 1 W. 10%	R-58	C5	VFO	Capacitor Disc .001 MF	T-509
R56	Multiplier F.A.	Resistor Wire Wound 1500 ohm 5 W. 10% Ohmite	R-79	C6	VFO	Capacitor Disc .001 MF	T-509
R57	Multiplier F.A.	Resistor Carbon 47 ohm 2 W. 10%	R-60	C7	VFO	Capacitor Ceramic Tubular 75 MMF ± 7.5 MMF, -750 Neg. Temp. Coeff.	T-647
R58	Multiplier F.A.	Resistor Carbon 47 ohm 2 W. 10%	R-60	C8	VFO	Capacitor Disc .001 MF	T-509
R27	Modulator S. A.	Resistor 10 Meg. 1/2 W. ±10% insulated	R-38	C9	VFO	Capacitor Disc .001 MF	T-509
R28	Modulator S. A.	Resistor Composition 5600 ohm 1/2 W. 10%	R-63	C78	VFO	Capacitor Ceramic Tubular 75 MMF ± 1% Zero Temp. Coef. uninsulated	T-751
R29	Modulator S. A.	Resistor Carbon 270,000 ohm 1/2 W. 10%	R-49	C79	VFO	Temp. Comp. Cap. N-750 ±120K 5±0.1 MMF	T-749
R30	Modulator S. A.	Potentiometer Composition .5 Meg.	T-612	C80	VFO	Temp. Comp. Cap. N-750 ±120K 50± 1 MMF	T-750
R31	Modulator S. A.	Resistor Composition 560 ohm 1/2 W. 10%	T-244	C10	Buffer Xtal Osc.	Capacitor Ceramic Tubular 50 MMF ±5MMF -750 Neg. Temp. Coeff.	T-616
R32	Modulator S. A.	Resistor Fixed Composition 1 Meg Ohm 1/2 W. 5%	R-7	C11	Buffer Xtal Osc.	Capacitor Ceramic Tubular 95 MMF ±9.5 MMF -750 Neg. Temp. Coeff.	T-643
R33	Modulator S. A.	Resistor Composition 330,000 ohm 1/2 W. 5%	R-32	C12	Buffer Xtal Osc.	Capacitor Disc .001 MF	T-509
R34	Modulator S. A.	Resistor Composition 5600 ohm 1/2 W. 10%	R-63	C13	Buffer Xtal Osc.	Capacitor Disc .001 MF	T-509
R35	Modulator S. A.	Resistor Composition 470,000 ohm 1 W. ±10%	R-69	C14	Buffer Xtal Osc.	Capacitor Disc .001 MF	T-509
R36	Modulator S. A.	Resistor Composition 470,000 ohm 1/2 W. 10%	R-66				
R37	Modulator S. A.	Resistor Composition 300 ohm 1 W. ±5%	T-626				

# PARTS LIST - MODEL 5100 TRANSMITTER

Circuit Symbol	Sub. Assy. Location	Description	B & W Part #	Circuit Symbol	Sub. Assy. Location	Description	B & W Part #
L12	Multiplier F.A.	Parasitic Choke	T-714	V12	Modulator S.A.	6146 Vacuum Tube	T-553
L13	Multiplier F.A.	Parasitic Choke	T-714	V13	Modulator S.A.	6146 Vacuum Tube	T-553
L14	Multiplier F.A.	Parasitic Choke	T-714	V14	Power Supply C.	OD3/VR150	T-128
L15	Multiplier F.A.	R. F. Choke Plate	T-710	V15	Power Supply C.	OC3/VR105	T-196
L16	Multiplier F.A.	High Frequency Coil	T-722	V16	Power Supply C.	5R4G Vacuum Tube	T-605
L17	Multiplier F.A.	Low Frequency Coil Pi-Network	T-721	V17	Power Supply C.	5R4G Vacuum Tube	T-605
L18	Modulator S.A.	R. F. Choke Filament	T-359	V18	Power Supply C.	5V4 Vacuum Tube	T-606
L19	Power Supply C.	R. F. Choke 2.5 uhy	T-359	T1	Modulator S.A.	Transformer, driver	T-548
L20	Power Supply C.	R. F. Choke 2.5 uhy	T-359	T2	Modulator S.A.	Transformer Modulation	T-549
L21	Power Supply C.	R. F. Choke 2.5 uhy	T-359	T3	Power Supply C.	Transformer High Voltage	T-545
L22	Power Supply C.	R. F. Choke 2.5 uhy	T-359	T4	Power Supply C.	Transformer Filament & Low Voltage	T-544
L23	Power Supply C.	R. F. Choke 2.5 uhy	T-359	X	Buffer Xtal Osc.	Crystal Socket	T-361
L24	Power Supply C.	R. F. Choke 2.5 uhy	T-359	CH1	Power Supply C.	Choke, power supply 5 hy	T-546
L25	Power Supply C.	R. F. Choke 2.5 uhy	T-359	CH2	Power Supply C.	Choke, power supply 8 hy	T-547
L26	Power Supply C.	R. F. Choke 2.5 uhy	T-359	CH3	Power Supply C.	Choke, power supply 8 hy	T-547
L27	Power Supply C.	R. F. Choke 2.5 uhy	T-359	TB1	Power Supply C.	Barrier Strip	T-638
L28	Power Supply C.	R. F. Choke 2.5 uhy	T-359	TB2	Power Supply C.	Terminal Strip 10 Terminal Special	T-604
V1	VFC	6BJ6 Vacuum Tube	T-645	I-1	Power Supply C.	Neon Lamp miniature bayonet base	T-597
V2	Buffer Xtal Osc.	6BJ6 Vacuum Tube	T-645		Power Supply C.	Relay Control	T-589
V3	Buffer Xtal Osc.	6BJ6 Vacuum Tube	T-645		Power Supply C.	Meter 3" rectangular base	T-599
V4	Multiplier F. A.	6AQ5 Tube	T-284		Power Supply C.	Fuse Holder	T-602
V5	Multiplier F. A.	6AQ5 Tube	T-284		Power Supply C.	Fuse 5 Amp. 125 volt	T-603
V6	Multiplier F.A.	6AQ5 Tube	T-284		Power Supply C.	2 Line Filters	T-680
V7	Multiplier F.A.	6AQ5 Tube	T-284		Power Supply C.	TVI Filter	Model 426
V8	Multiplier F.A.	6146 Tube	T-553		Front Panel—	2 Pilot Lights	T-703
V9	Multiplier F.A.	6146 Tube	T-553		Dial Assy.		
V10	Modulator S.A.	6U8 Vacuum Tube	T-635				
V11	Modulator S.A.	6AQ5 Vacuum Tube	T-284				

# INSTRUCTION MANUAL - MODEL 5100 TRANSMITTER

## ADDENDA SHEET #1

### NOTE

The following changes have been made to current production units. These changes are not indicated by the schematic diagram in the present instruction manual, however, the parts list is up to date and includes the items used for the changes indicated below. —

1. Add 2 Resistors R60 & R61 — 100K, 2 watts in parallel, shunted across secondary of Modulation transformer T2.
2. Add 2K Resistor 10 watts R62 from terminal #3 on V15 to ground.
3. Connection change on high voltage screen feed supply lead — from SW4 section (C) contact #3 to J#5 terminal #3.
4. Buffer — XTAL — OSC. Unit — change circuit symbol reading P2 to read J9.
5. Multiplier Final Amplifier — change value of C44 from .005 MMF. to read .005 MF.
6. Add 10,000 ohm 1/2 watt 20% Resistor (R63) in series with high side of microphone lead. Change to take place inside of chassis, under shield cover.
7. **MICROPHONE CORD CONNECTOR FITTING**  
The Microphone Cord Connector (Not Supplied) is an Amphenol 80-MC2M. Refer to page 6 of the instruction Manual for proper wiring polarity.
8. **CAMLOCK FASTENERS**  
Reference to the 2 Camlock Fasteners and cutaway drawing contained on page 6 under the title of "Maintenance" should be deleted. These items have been omitted due to the difficulty they produced in withdrawing the chassis from the Cabinet.
9. **MODEL 5100 TUNING GUIDE**  
The following dial settings are average when the Model 5100 Transmitter is terminated into a 75 ohm non-inductive load circuit. Antenna loads should be such that the following settings be approximated as closely as possible.  
Final plate current for the following settings is 220 ma. in the "FONE" position. "CW" position will vary somewhat from this value.
10. **CAUTION**  
When no microphone is attached to the front panel connector, the audio gain control **MUST** be retarded to the full counter-clockwise position. Failure to do so may produce arcing at the modulation transformer output safety gap.

### DIAL SETTINGS

Frequency (KC's)	Loading	Tuning
3500	3.0	8.0
4000	5.0	6.0
7000	2.0	5.0
7300	2.5	4.5
14000	2.0	4.5
14350	2.1	4.0
21000	3.0	2.5
21450	3.1	2.5
26960	2.0	4.0
27230	2.0	4.0
28000	2.0	3.5
29700	2.5	2.5

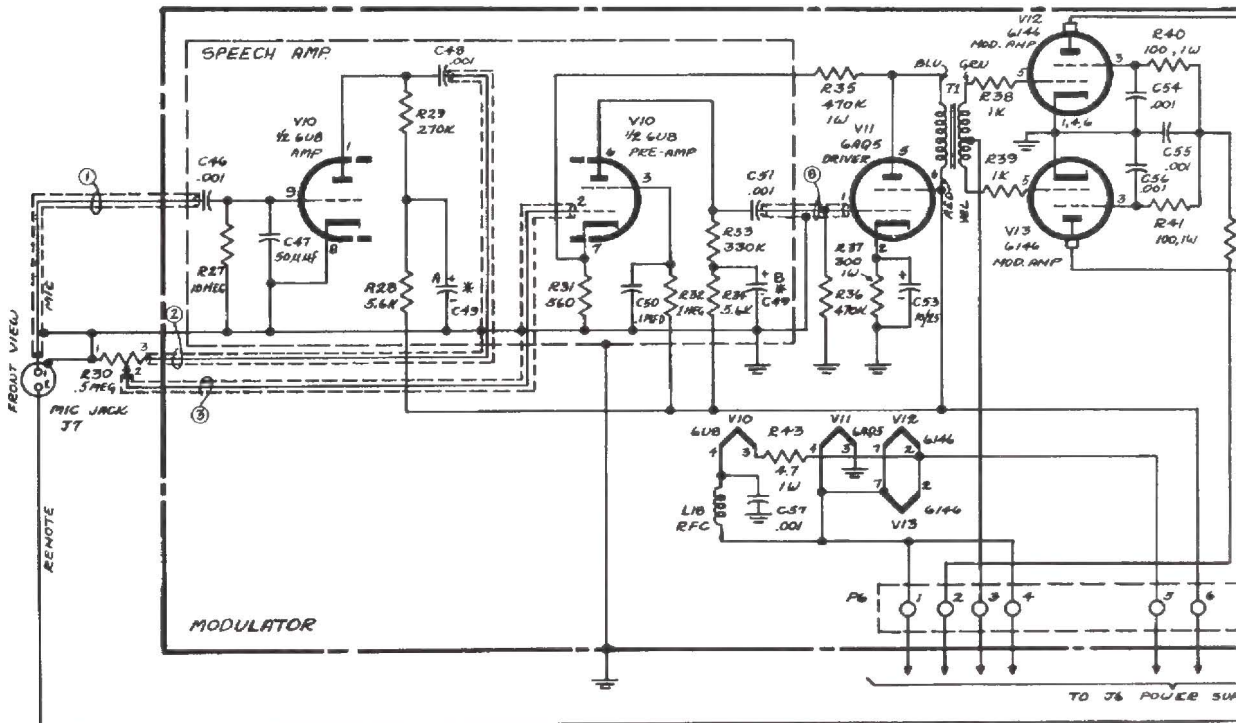
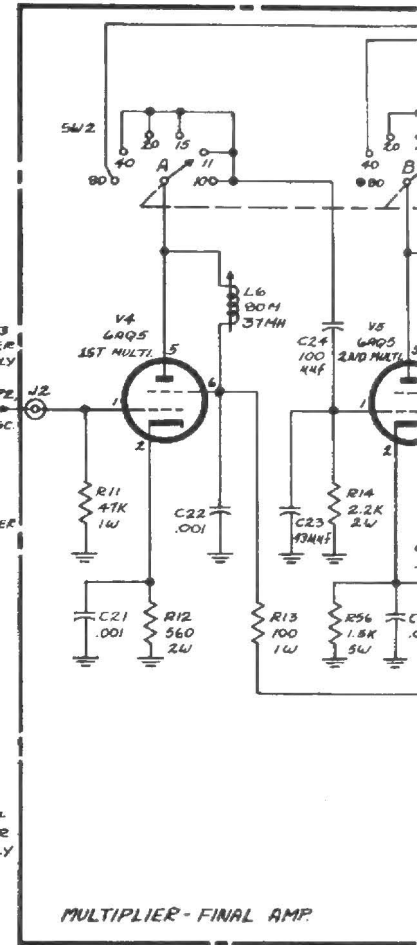
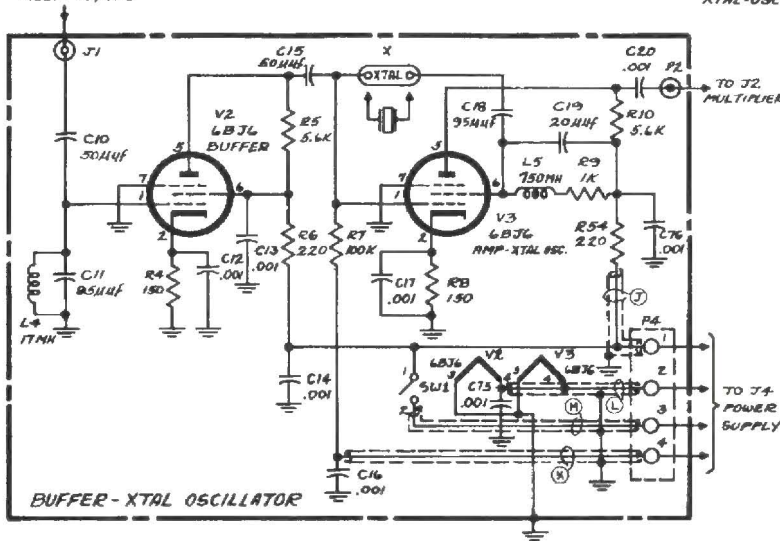
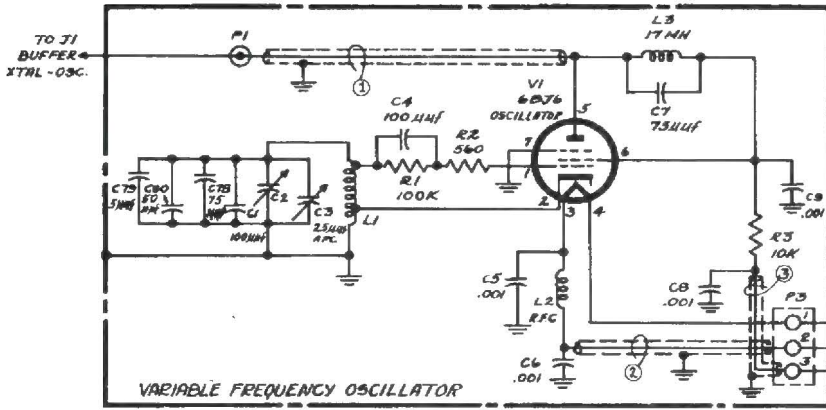

B&W 5100  
1/3



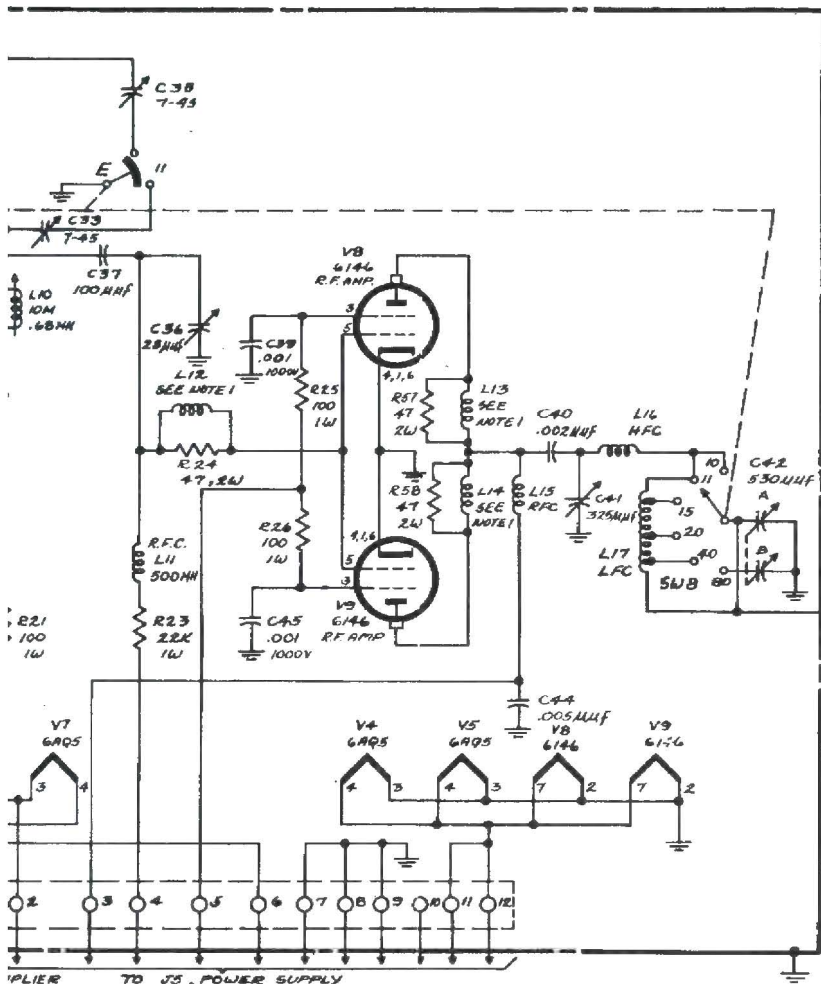

NOTES  
 1. PARASITIC SUPPRESSOR 3 1/2 TURNS  
 NO. 18 TUNED WIRE ON RESISTOR 47, 2W.  
 2. CAPACITORS ARE IN MF UNLESS  
 OTHERWISE SHOWN. ALL RES. ARE IN  
 OHMS AND ARE 1/2 WATT UNLESS OTHERWISE  
 SHOWN  
 \* - C49 A & B - 2 CAP. IN ONE SHIELD  
 A - R53 - SPECIAL RESISTOR.

LOW PASS FILTER  
 B&W

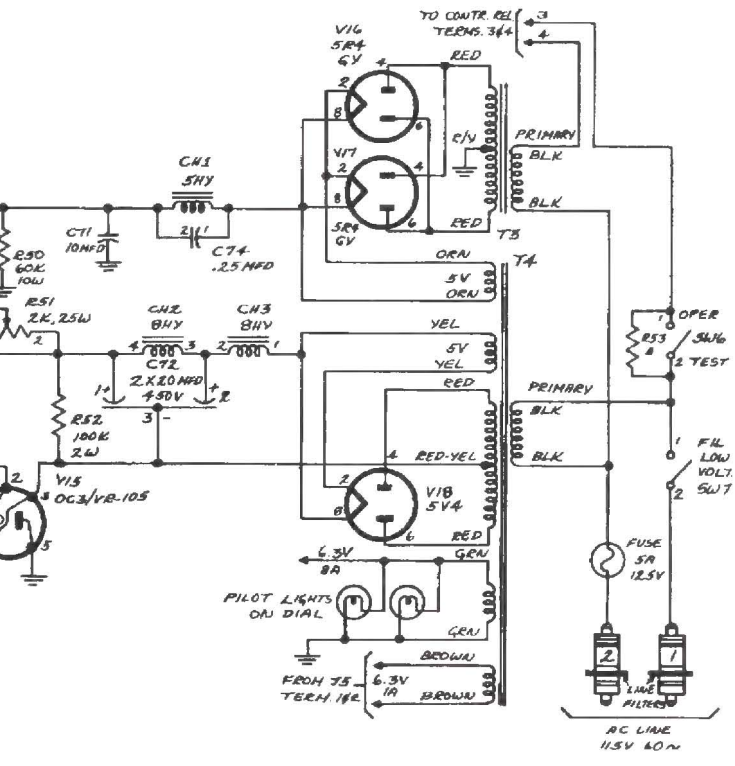
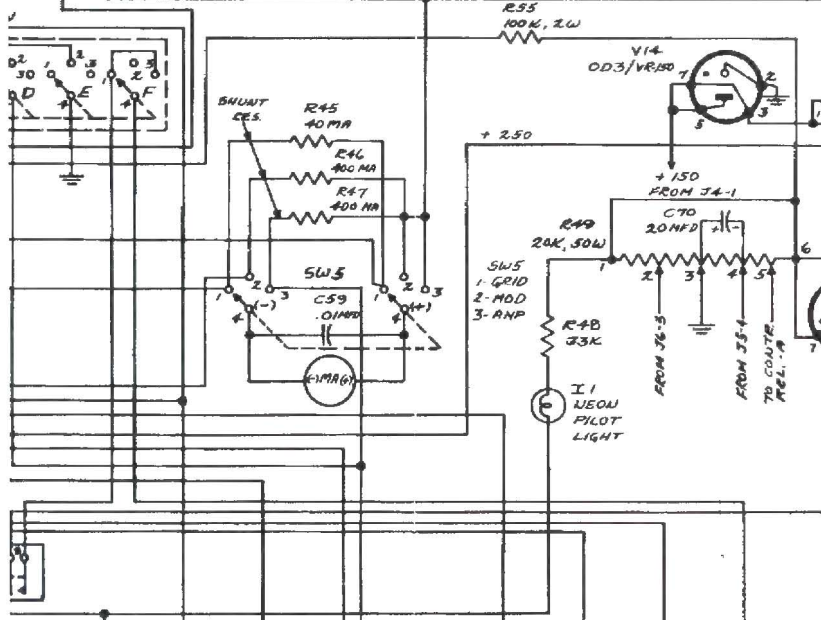
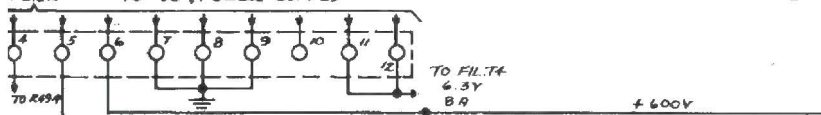

POWER SUPPLY

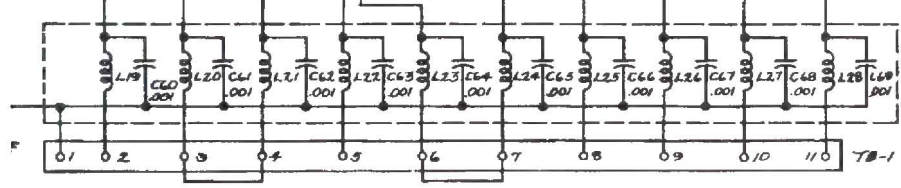

B&W 510C  
 3/3