

The New



Breting

"14"



NOISE SILENCER AND DISCONNECTING SWITCH →

COMMUNICATION SWITCH →

← BFO SWITCH

← RF GAIN CONTROL

← AUDIO VOLUME CONTROL

← CRYSTAL PHASING CONDENSER

← TUNING CONTROL

← BAND SELECTOR SWITCH

← TONE CONTROL AND AC SWITCH

CUSTOM BUILT... RADIO

OPERATING INSTRUCTIONS

A PERSONAL MESSAGE

It is our sincere desire that Breting users obtain from their receiver the utmost in satisfactory performance, and it is with that in mind that we offer the information which is contained in the following paragraphs. We cannot emphasize too strongly the necessity of carefully and thoroughly reading these operating instruction notes, and, even though the operator feels that he might be thoroughly familiar with the operation of this type receiver, we still insist that he should not overlook the importance of giving a few moments' time to this most necessary initial procedure.

We have endeavored to cover a considerable amount of information in this booklet without going into intricate details, but we are confident that the information given will enable the operator to enjoy the satisfaction which this receiver merits if he will follow out the instructions carefully.

Bretling "14"

OPERATING AND GENERAL INSTRUCTIONS

ANTENNA: To insure best results it is absolutely essential that a first-class antenna be used. We recommend a single solid wire, 50-75 feet in length, including lead-in. Height over any obstruction in the immediate vicinity is, of course, highly desirable, and should be obtained whenever possible. An ideal situation with respect to antenna would be the use of two or three antennas running in different directions and using a switch mounted near the radio. This procedure would enable the operator to select the antenna giving the best results in any particular location.

On the higher frequencies a short antenna will usually give better results, and on the 10 meter band a 16 ft. vertical generally proves most efficient.

The only advantage obtained in using a doublet antenna would be to locate the antenna pick-up portion out of a noisy field, such as is usually found in a location near a street car line or much traveled highway. In locations of this kind the antenna proper can be located as far away as possible from the disturbing factor, and the long lead-in can be brought to the receiver without a great amount of loss. Almost all commercially made doublets are furnished with the matching transformer equipped with electro-static shields to eliminate any capacity pick-up in the lead-in. There are many coupling transformers on the market that may be obtained by anyone who desires to construct their own doublet, but when this is done a matching transformer should be used that is equipped with electro-static shield.

SPEAKER BAFFLE: The 12-inch speaker supplied with the receiver requires a baffle of at least 4 ft. tone travel. Needless to say, the wall of a room makes an ideal baffle, but if a wall is used it is important that the rear of the speaker be open to give best possible tone quality. Any kind of soft heavy material such as white pine or Celotex makes an ideal material to use. To add auxiliary speaker, use one of the permanent magnet dynamic type, and connect across the two wires that lead to the small prongs of the speaker plug which is furnished as regular equipment with the receiver.

NOISE SILENCER CONTROL: The noise silencer is equipped with a filament switch that turns the two noise silencer tubes off when in the extreme left position. To operate the silencer the control should be turned to the right, and after the tubes have had sufficient time to heat advancing the control will cause the set to block when a station is tuned in. The point of operation is very critical and just below the blocking point. The weaker the signal the more effective becomes the noise silencer. It is worthless on a strong signal and on certain types of noise. The silencer cannot be used on local or extremely strong signals. The silencer is not a cure-all for static generally speaking, but it is very efficient in eliminating certain types of interference.

COMMUNICATION SWITCH: The communication switch disconnects the audio amplifier from the radio and connects it to the tip jacks on the rear of the chassis. The middle terminals on rear of chassis are connected to the 200 ohm line, the bottom one of which is grounded to the chassis. The terminals nearest the speaker plug when opened break the B+ to the RF portion of the receiver. Needless to say, these terminals are hot

with respect to the chassis. The audio amplifier will drive any type of final amplifier, and if used as a modulator, will modulate approximately 100 watts. When using the receiver as a modulator, a modulation transformer with a 200 ohm primary and a secondary with a correct load to match the transmitter must be used. Numerous speaker transformers when reversed will operate satisfactorily for this purpose and several manufacturers have special transformers expressly made for this service, such as Inca Models N18 and N17.

A large number of amateurs are modulating at speech frequencies, 100W transmitters. In case feed back difficulties are encountered, try reversing connections on the external transformers and shielding all connecting wires. Sometimes a separate switch on the B+ terminals will be necessary while transmitting. A microphone transformer and volume control will be necessary for high level carbon microphones, and a high gain preamplifier is necessary for low level microphones. A single high gain stage is generally sufficient for the diaphragm type crystal microphone.

The filament and plate power for the preamplifier stage can be supplied by the receiver. On rotary type communication switch extra terminals are supplied to turn transmitter on with the communication switch.

AUDIO VOLUME CONTROL: The audio volume control is connected between the first audio and the second detector.

CRYSTAL PHASING CONDENSER: To obtain results with the crystal circuit, a complete understanding of crystal selectivity must be had by the operator.

Let us consider the ordinary C. W. signal as received by a super with the crystal in the off position. The band width of the carrier is about 10,000 cycles and is heard as a series of dot and dash hissing sounds as the receiver is tuned thru the range of the 10,000 cycles. If the beat oscillator is turned on and adjusted when the dial is set to the center of the carrier, you will notice that the C. W. signal becomes a howl and the pitch varies as the beat oscillator adjustment is turned from one side to the other. It starts as an extremely high pitch howl down to a zero beat point and then up the other side until the pitch becomes so high it is lost to the ears.

Now set the beat oscillator until a 1,000 cycle note is heard. Next adjust the crystal trimmer until the background noise is at minimum and a ringing sound is heard in the speaker. The C. W. signal will probably have been lost during this operation and the main dial will have to be readjusted until you find the narrow peak of the signal.

Remember that the peak of the crystal is only 50 cycles wide compared to 10,000 cycles without crystal. You can understand by comparing the above figures why the average amateur never finds the C. W. peak on the crystal and is ready to condemn its performance. The signal strength should not change as the trimmer is turned from the left hand off position to the right hand position.

Greatest selectivity of the crystal will be found as the trimmer is turned about two-thirds of the way to the right. If the signal strength changes as the trimmer is adjusted, the signal is not tuned in on the peak or else the beat oscillator is not adjusted 1,000 cycles to one side of zero beat. Different degrees of selectivity can be obtained on C. W. by not bringing the crystal trimmer in exact

phase. The broad positions are on either side of where minimum noise is heard.

For phone reception leave beat oscillator off and keep crystal in either position. At best the reception will be poor.

On C. W. turn the volume control three-quarters on and use the manual control to bring up the signal level. Do not advance it too far on the crystal as it will overload the first detector and motor boating will result.

TUNING CONTROL: The tuning control has a simplified 2-speed action that automatically goes into high speed after the large knob has been rotated three times in either direction. If fairly slow speed tuning is desired, remove the brass arms behind the large knob. This can be accomplished by merely removing the knob itself.

BAND SWITCH: Trimmers and coils are mounted on the band switch and should not be tampered with. Rotate the band switch slowly to allow the calibrated dial to follow with the least amount of strain and to minimize arcing in the contacts.

STONE CONTROL AND AC SWITCH: The tone control carries the AC switch and turning same to left hand position disconnects the radio from the AC line. It is not necessary to turn any of the other controls to accomplish this purpose. This allows the user to leave the radio tuned to any station and upon returning only the AC switch need be turned.

BEAT FREQUENCY OSCILLATOR SWITCH: The beat oscillator control turns the R meter off and converts the vacuum tube volt meter tube into a beat oscillator. It also shorts out the AVC circuit requiring the manual volume control to be turned to the left to keep from blocking the receiver.

To locate weak stations, turn beat oscillator switch to the right. This should produce a hissing sound in the speaker, and as the tuning dial is rotated, all stations will be heard with a definite squeal. After locating station, retune to greatest volume.

Adjust beat oscillator by turning the condenser shaft extending through the bottom front, left corner until the desired pitch is obtained. To make the beat oscillator adjustable from the front panel solder a heavy wire or handle to the shaft and allow it to extend out under the base pan.

RF GAIN CONTROL OR MANUAL VOLUME CONTROL: The RF gain control is used for code reception and should be rotated to the left when silent tuning is desired.

R METER ADJUSTMENT: To adjust the R meter, disconnect the antenna, and after the receiver has been on a few minutes, turn the control marked "R" METER ADJUSTMENT until the pointer swings to the maximum left hand position. The meter is at ground potential and cannot be damaged except through rough handling in a mechanical way.

ANTENNA TRIMMER ADJUSTMENT: Adjust the antenna trimmer on any station around 14 megacycles. Turn adjusting screw carefully until greatest signal strength is shown on the R meter. DO NOT ADJUST ANY OTHER TRIMMERS. The trimmer is adjusted correctly at the factory and should not require over 1/2 turn in either direction.

GUARANTEE

The manufacturer warrants each new Bretling receiver manufactured by it to be free from defects in material and workmanship under normal use and service, its obligation under the warranty being limited to making good at its factory any part or parts thereof, including tubes and speaker, which shall within ninety (90) days after making delivery of such receiver to the original purchaser be returned to it with transportation charges prepaid, and which its examination shall disclose to its satisfaction to have been thus defective; this warranty being expressly in lieu of all other warranties expressed or implied and of all other obligations or liabilities on its part, and it neither assumes nor authorizes any other person to assume for it any liability in connection with the sale of its receivers. This warranty shall not apply to any receiver which shall have been repaired or altered by anyone outside of ourselves, nor which has been subject to misuse, negligence or accident.

8-158258-3

SUPPLEMENT to OPERATING INSTRUCTIONS

Breting • "14" ***AX***



The above specifications covering the various controls supercedes those shown in the New Breting 14 operating instructions.

All information pertaining to the individual controls as shown in the Instructions remains the same, no changes having been made in their various functions.

BRETING RADIO MANUFACTURING CO.

2117 Venice Boulevard

Los Angeles, California

Tune the Intermediate Freq trans to resonant point of Crystal. This point may be 200 to 1000 cycles different from the osc point of the crystal (if crystal was used as oscillator control). Adjust IF trans in following sequence:

- (1) Align the 2nd IFT stage
- (2) Band pass IF stage located in center of chassis
- (3) Crystal grid coil
- (4) 1st Detector plate coil (on rear of chassis)

Place crystal in the filter circuit, tune in a low freq broadcast station of 600kc adjust sensitivity cont until "R" meter reads 40. Then phase crystal and retune dial to min. modulation and max. R strength location. Turn crystal off, without disturbing dial, retune IF trimmers as before to greatest R strength. Next align crystal resonant point with the IF. Crystal osc not necessary if IF adjustment have not been disturbed.

To adjust Low Freq. of each band, Trimmers are located on top of chassis, 75 meter trimmer located on rear, High freq trimmers are located on coil sw, at most trimmer shall not require more than 1/8" turn.

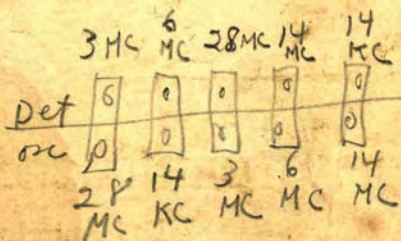
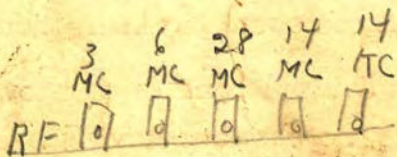

214





Breting

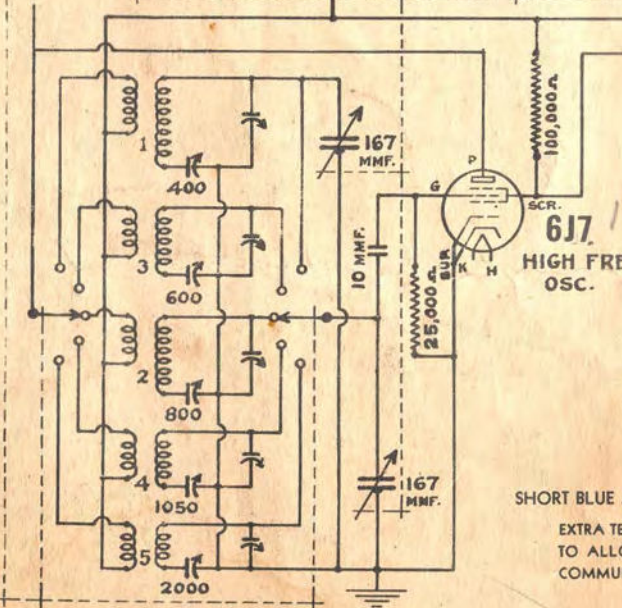
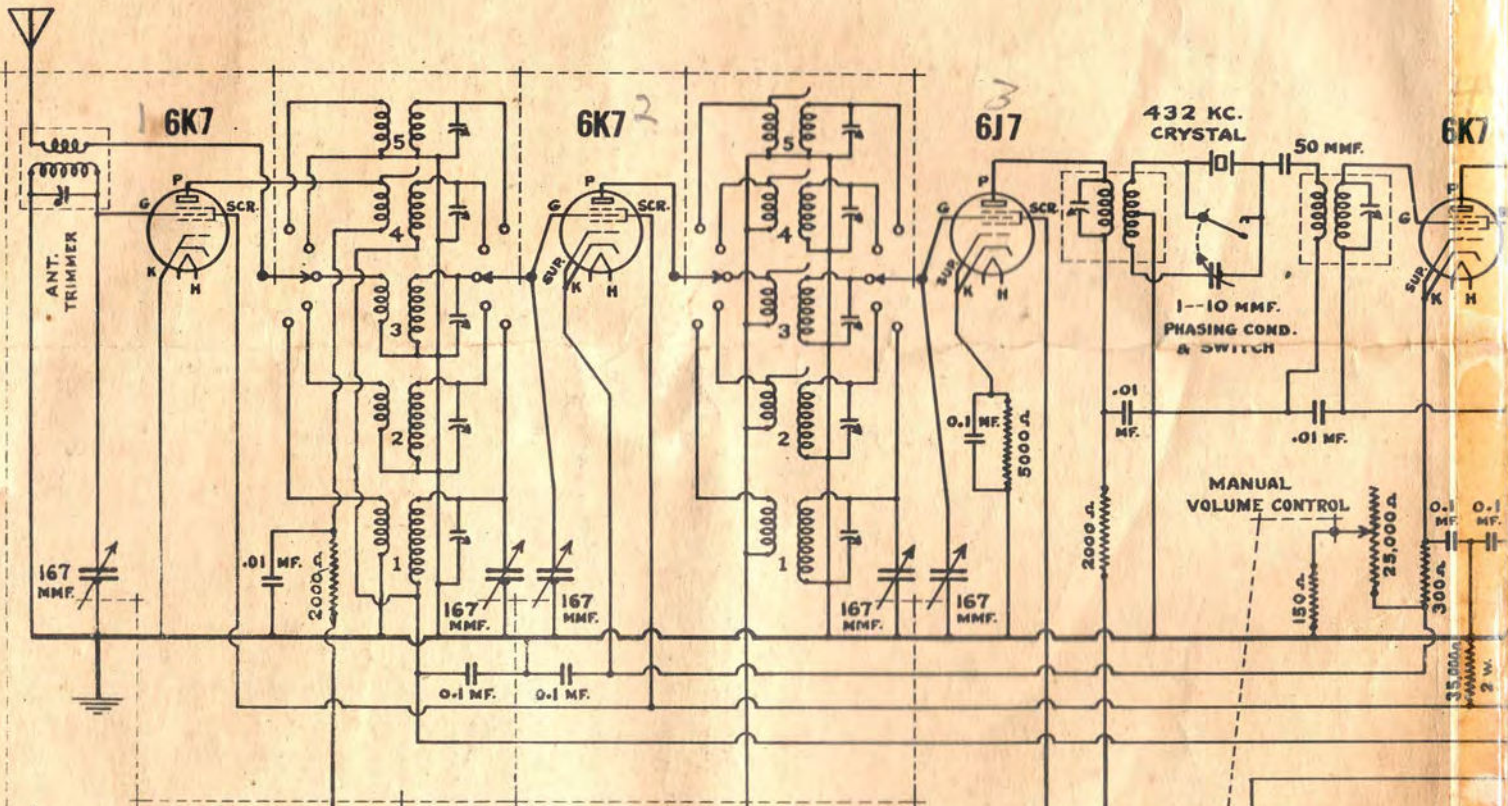

COILS
 NOS 1 & 4 ARE ON SAME FORMS
 " 3 & 5 " " " "
 " 2 ARE ON SEPARATE FORMS
 1ST R.F. IS IN CAN WITH ANT. TRIMMER

**OPTIONAL COMBINATIONS
 FOR CONNECTING
 COMMUNICATION SWITCH**

SHORT BLUE AND YELLOW WIRES FOR PHONOGRAPH USE
 EXTRA TERMINALS ARE SUPPLIED ON ROTARY SWITCHES
 TO ALLOW TRANSMITTER TO BE TURNED ON WHEN
 COMMUNICATION SWITCH IS IN TRANSMIT POSITION

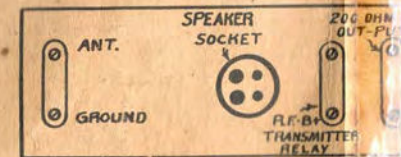

REAR VIEW OF CHASSIS

ABOVE VALUES
 IN MMF.

MANUFACTURED BY

BRETING RADIO MANUFACTURING CO.

2117 VENICE BOULEVARD

LEWIS

"14"

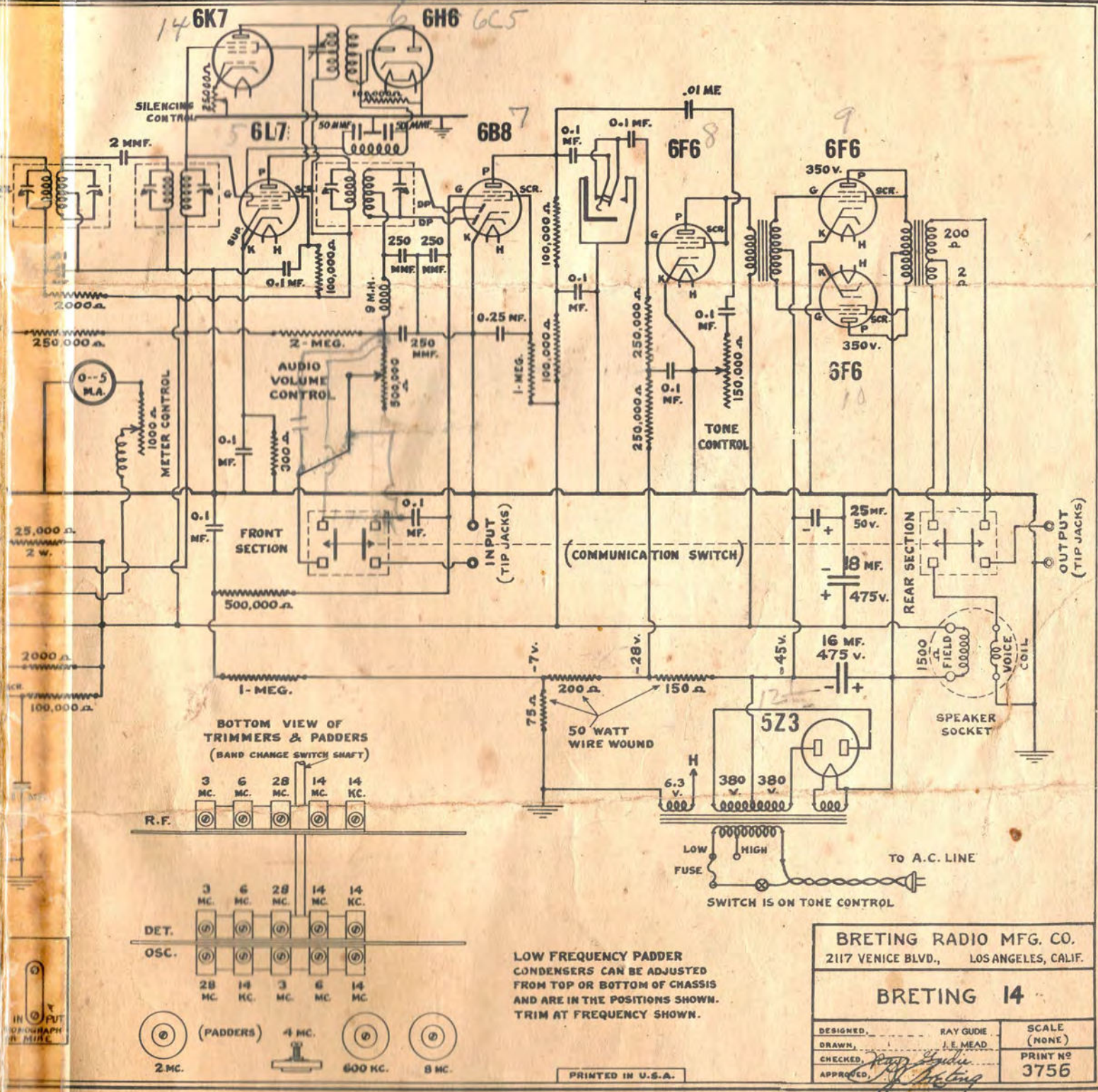

BOTTOM VIEW OF TRIMMERS & PADDERS (BAND CHANGE SWITCH SHAFT)

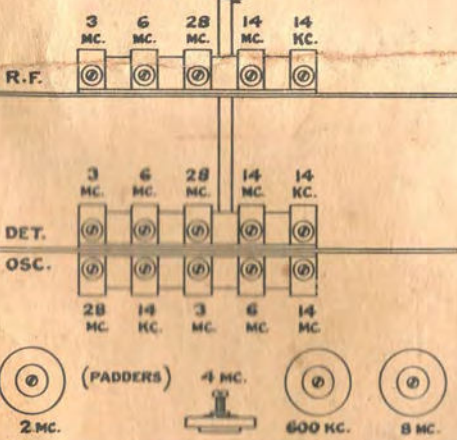

LOW FREQUENCY PADDERS
CONDENSERS CAN BE ADJUSTED
FROM TOP OR BOTTOM OF CHASSIS
AND ARE IN THE POSITIONS SHOWN.
TRIM AT FREQUENCY SHOWN.

PRINTED IN U.S.A.

BRETING RADIO MFG. CO.
2117 VENICE BLVD., LOS ANGELES, CALIF.

BRETING 14

DESIGNED, RAY GUDIE	SCALE (NONE)
DRAWN, J.E. MEAD	PRINT NO 3756
CHECKED, <i>Ray Gudie</i>	
APPROVED, <i>J.E. Mead</i>	

MANUFACTURED BY
FACTURING COMPANY
LOS ANGELES