

||
Eddystone

||
**UHF
COMMUNICATION
RECEIVER
MODEL 770U (MK. II)**

**EDDYSTONE RADIO LTD.
ALVECHURCH ROAD
BIRMINGHAM 31**

EDDYSTONE MODEL 770U (Mk.II)

UHF COMMUNICATION RECEIVER

The EDDYSTONE Model 770U (Mk.II) is a double conversion communication receiver covering the frequency band 150-500 Mc/s in six turret-switched ranges. Provision is made for reception of both AM and WBFM signals and the receiver operates directly from all standard AC mains supplies.

Outputs are available for use with either an external speaker or high impedance telephones, while a line output (600Ω) allows the receiver to be installed at some distance from the listening point. The audio stages incorporate push-pull output and are capable of extremely good quality. A low-level recording output is provided and the circuit arrangements permit the audio stages to be used separately if required.

The receiver can be used in conjunction with the Eddystone Model EP17R Panoramic Display Unit to provide full panoramic facilities over the range 150-500 Mc/s. A low-level wide-band IF output is provided for this purpose and the complete installation which includes a monitor speaker mounted in a base plinth is then referred to as the Model EPR25 Panoramic Receiver.

Other facilities which are standard features of the receiver include an extremely efficient muting circuit, a built-in crystal calibrator and a carrier level meter which can also be used as a tuning indicator for FM reception. A separate noise limiter is fitted for AM reception and a narrow band IF output is available from a cathode follower at the 2nd IF. External converters can be fed into the receiver at a socket which connects to the 1st IF Stages (50 Mc/s).

Surface-mounting or rack-mounting versions are available, the latter being suitable for installation in a standard 19" rack. Rugged construction and high quality components are used throughout and the receiver is suitable for continuous operation under adverse climatic conditions.

LIST OF CONTENTS

<u>Section</u>	<u>Page</u>
Technical Data	2
Circuit Description	4
Constructional Details	8
Installation	10
Operation	12
Maintenance	15
<u>Appendices</u>	
Appendix "A" Voltage Analysis	22
Appendix "B" List of Component Values, Tolerances and Ratings	23
Appendix "C" Spares	27
<u>Illustrations</u>	
Fig. 1. Block Schematic Diagram of 770U (Mk.II) Receiver	31
Fig. 2. Plan View of 770U (Mk.II) Receiver	32
Fig. 3. Underside View of 770U (Mk.II) Receiver	33
- Circuit Diagram	Rear cover

The Company reserve the right to vary the information contained in this publication.

Sole Manufacturers:- EDDYSTONE RADIO LTD., ALVECHURCH ROAD, BIRMINGHAM 31, ENGLAND

TECHNICAL DATA

GENERAL

Frequency Coverage.

150-500 Mc/s in six ranges.

Range 1	400 - 500 Mc/s.	Range 4	220 - 270 Mc/s.
Range 2	330 - 400 Mc/s.	Range 5	180 - 220 Mc/s.
Range 3	270 - 330 Mc/s.	Range 6	150 - 180 Mc/s.

Intermediate Frequencies.

1st IF 50 Mc/s. 2nd IF 5.2 Mc/s.

Valve and Semiconductor Complement.

Ref	Type	Circuit Function
V1	6AM4 - (CV5073)	RF Amplifier (grounded-grid).
V2	6AF4A - (CV5074)	1st Local Oscillator.
V3	12AT7 or ECC81 (CV455)	1st 50 Mc/s IF Amplifier (cascode).
V4	6AK5 or EF95 (CV850)	2nd 50 Mc/s IF Amplifier.
V5	12AT7 or ECC81 (CV455)	2nd Mixer / 2nd Local Oscillator.
V6	6BA6 or EF93 (CV454)	1st 5.2 Mc/s IF Amplifier.
V7	6BA6 or EF93 (CV454)	2nd 5.2 Mc/s IF Amplifier.
V8	6AU6 or EF94 (CV2524)	5.2 Mc/s Cathode Follower.
V9	6AU6 or EF94 (CV2524)	FM Limiter.
V10	6AL5 or EB91 (CV140)	FM Discriminator.
V11	6AL5 or EB91 (CV140)	Noise Limiter / AVC Rectifier.
V12	6AM6 or EF91 (CV138)	Crystal Calibrator.
V13	6AU6 or EF94 (CV2524)	Noise Amplifier.
V14	12AU7 or ECC82 (CV491)	1st AF Amplifier / Muting Control.
V15	12AU7 or ECC82 (CV491)	Phase Splitter / Meter Control.
V16	6AM5 or EL91 (CV136)	Push-pull Audio Output.
V17	6AM5 or EL91 (CV136)	
V18	150C3 or VR150/30 (CV216)	HT Stabiliser.
V19	5Z4G or GZ30 (CV2748)	HT Rectifier.
D1	GEX66 - -	1st Mixer Stage.
D2	GEX13 - -	AM Detector.
D3/4	GEX13 - -	Noise Rectifier.
TR1	BFY19 - -	Tone Oscillator (Crystal Calibrator).

Input and Output Impedances.

Aerial Input	75Ω (nominal) unbalanced.	
Audio Input	0.1MΩ (approx.).	
IF Input (IF1)*	75Ω (nominal) unbalanced.	*Can also be used as a low level 50 Mc/s o/p.
IF Output (IF2)†**	75Ω (nominal) unbalanced.	†For use with EP17R.
IF Output (IF3)**	75Ω (nominal) unbalanced.	**Matching is not critical.
Audio Output	Loudspeaker	:: 2.5/30.
		Lines	:: 600Ω (balanced or unbalanced).
		Telephones	:: Nominally 2000Ω but suitable for a wide range of impedances.

Power Supply.

Single-phase AC mains 100/125V and 200/250V (40-60 c/s). Consumption : 90VA

Fusing.

The live side of the mains input is fused at 1 Amp with a standard 1 $\frac{1}{4}$ " cartridge type fuse. The fuseholder is located at the rear of the receiver.

TYPICAL PERFORMANCE FIGURES

Sensitivity.

Better than 10 μ V for an output of 50mW with a s/n ratio of 15dB. (Taken with 50% modulation at 400 c/s).

Image Rejection.

Range 1	..	20dB down.	Range 4	40dB down.
Range 2	..	30dB down.	Range 5	45dB down.
Range 3	..	30dB down.	Range 6	50dB down.

Selectivity.

The overall IF response is 6dB down 20 kc/s off and 20dB down 50 kc/s off. The Discriminator will accept a deviation of 10 kc/s with negligible distortion.

Frequency Stability.

The overall drift does not exceed 1 part in 10⁴ per °C change in temperature after a warm-up period of 15 minutes.

IF Breakthrough.

Breakthrough at the 1st IF (50 Mc/s) is of the order 40dB down and breakthrough at the 2nd IF (5.2 Mc/s) 110dB down. Both measurements taken at 160 Mc/s on Range 6.

AVC Characteristics.

The audio output level does not change by more than 12dB when the input is varied 60dB above 10 μ V.

Muting Level.

The pre-set muting adjustment can be set so that signals as low as 10 μ V at the aerial input will release the muting control circuit.

Audio Output and Response.

The push-pull Audio Output Stage will deliver up to 2.5 watts of audio power at the 2.5 Ω terminals. An output of 1 watt is available at 5% distortion and the frequency response is level within 3dB from 200 c/s to 10 kc/s.

Audio Sensitivity.

A 200mV signal (1,000 c/s) at the AF Input terminals will produce an output of 50mW with the AF GAIN set to maximum.

CIRCUIT DESCRIPTION

The RF Section.

This portion of the receiver comprises the two triodes V1 & V2 and the germanium diode D1. Advanced VHF/UHF techniques are used throughout and all circuitry is closely integrated with the compact split-stator gang assembly employed for tuning. Standard miniature fixed capacitors are used except in those positions where improved performance is obtained by forming the capacitor as an integral part of the gang (e.g. C4 and C5). The valveholders are specially fabricated types which incorporate silver-plated connecting straps to keep lead inductance down to an absolute minimum.

Associated with the gang assembly is a six-position coil turret which introduces the appropriate inductors etc. for use on each range. The turret features self-cleaning contacts and is of extremely robust construction. Positive selection of the desired range is assured by the rugged mechanical drive, while indication of the range in use is given by six pilot lamps on the main dial. The lamp display is controlled by S7 which is linked to the range selector mechanism.

The RF Amplifier (V1 : 6AK4) is operated in grounded-grid and maintains a low μ/f throughout the range. Signal input is to the cathode and except on Range 1 is derived from a low impedance link on the first tuned circuit (L3, L6 etc.). The aerial feeder is taken to a tap on the tuned winding to give a nominal input impedance of 75 Ω on all ranges. On Range 1 the input circuit is untuned and the cathode return is completed by the miniature RF choke CH5. The 1-5pF trimmer (395) is adjusted during test to give the best image figure on this range and the aerial feeder is coupled to the cathode via C92 (20pF).

The anode circuit of the RF Stage is tuned by one section of the split-stator gang (C2) and is coupled to the diode 1st Mixer Stage (D1 : GEX66) by a low impedance link, one end of which is directly earthed. Injection to the diode from the Local Oscillator is in parallel with the signal input, the actual coupling arrangements being different on some ranges from others. Examination of the individual coil strip wiring diagrams will reveal the exact configuration for any particular range.

Output from the 1st Mixer Stage is taken from the cathode of the diode to a tap on the tuned primary winding of the 1st 50 Mc/s IF transformer T1. The untuned secondary on this transformer feeds the 1st 50 Mc/s IF Amplifier via a short length of coaxial cable.

The Local Oscillator (V2 : 6AF4A) employs the ultradion circuit, operates in the fundamental mode and tracks above the signal at all frequencies up to 330 Mc/s. Above this frequency the oscillator is run on the "low" side to maintain a high degree of frequency stability. The tuning scales are individually calibrated and the precision wound inductors, once set during initial alignment, will not require adjustment in any subsequent re-alignment. Air-spaced trimmers are provided on all oscillator coils and on all other coils except Range 1 Mixer.

HT for both the RF Amplifier and the 1st Local Oscillator is taken from the 150V stabilised HT supply (HT2), the actual voltage applied to the oscillator anode being adjusted from range to range by CH6, R89, R91 etc. The cathode bias resistor R4 is included to keep the oscillator anode dissipation within its limits when using Range 1.

The whole of the RF Section is mounted in a screened compartment which also houses the 1st 50 Mc/s IF Amplifier (V3). The Crystal Calibrator is mounted on the top cover of the RF Unit, its output being taken directly to the aerial input socket via a small coupling capacitor.

50 Mc/s IF Amplifiers.

Two stages operate at the 1st IF of 50 Mc/s, namely V3 (12AT7) and V4 (6AK5). The former employs the shunt cascode configuration and preserves the low noise figure achieved by employing a diode in the 1st Mixer Stage. The other 50 Mc/s Amplifier is operated as a normal pentode.

V3 is located inside the RF screening box and is fed from the 1st Mixer Stage via a short length of 75Ω coaxial cable terminating in a link winding on the grid transformer T2. The secondary winding is resonated by the valve capacity and a further link is provided to permit connection to SKT2. This socket (marked "IF1") is intended as a connection point for an externally derived 50 Mc/s signal, but can also be used as a low level output at the 1st IF.

SKT2 can be fed from the output of a converter specially designed to extend the frequency coverage of the 770U or alternatively from a converter tuned to a "guard" frequency either within or outside the tuning range. In either case simultaneous reception will be possible on both normal and "guard" channels, separate aërials being used for the receiver and converter.

The cascode stage is coupled to the pentode amplifier V4 (which is located on the main IF chassis) via a coaxial cable linking T3 and T4. V4 is effectively a "buffer" stage and is the first amplifier to which AVC is applied. Manual gain control is effected by RV1 (IF GAIN) which is included in the cathode circuit. The range of adjustment provided by this control is increased by supplying a bleed current from the main HT rail via the 0.27MΩ resistor R16. Standby switching is performed by the toggle switch S1 which introduces a 47,000Ω resistor (R14) in series with the gain control.

2nd Frequency Conversion and 5.2 Mc/s Amplifiers.

The final 50 Mc/s transformer (T5) couples the 2nd 50 Mc/s Amplifier to the grid of the 2nd Mixer Stage (V5A : $\frac{1}{2}$ 12AT7). The other half of the 12AT7 serves as the 2nd Local Oscillator and employs an ultradion circuit tuned 5.2 Mc/s below the 1st IF. V5 and its associated circuitry (including T6 and T7) is housed in a small screened box which is mounted on the IF chassis. All supply leads are filtered at their point of entry to limit radiation from wiring external to the unit. The AVC feed to the grid of the Mixer is filtered in a similar fashion.

IF output from the Mixer Stage is fed to the first of the two 5.2 Mc/s Amplifiers (V6 & V7 : 2 x 6BA6) through the 1st 5.2 Mc/s IF transformer T6. Both V6 and V7 have AVC applied and the final stage feeds V8, V9, V11B, V13 and the germanium diode D2.

A low level 5.2 Mc/s output is provided at SKT3 (marked "IF2") for feeding the EP17R Panoramic Display Unit when the receiver forms part of the EPR25 Panoramic Installation. The output is derived from an 82Ω resistor (R20) which is included in the earth return of the decoupling capacitor C26 in the anode circuit of the 2nd Mixer Stage V5A. The bandwidth at this point exceeds one megacycle and a full width display can therefore be presented on the EP17R Unit.

AM Detector and Noise Limiter.

A germanium diode (D2 : GEX13) is employed for detection when taking AM signals. The circuit is conventional and incorporates one half of a 6AL5 double-diode (V11A) as a series type Noise Limiter. This stage can be switched in or out as required by the toggle switch S3 and is effective against impulse noise of the type originating in ignition systems etc.

Output from the AM Detector is routed to the AM side of the MODE switch S4a and thence to the AF GAIN control RV2.

5.2 Mc/s Cathode Follower.

V8 (6AU6) provides a low impedance output at the 2nd IF for connection to ancillary equipment. The output bandwidth is that of the receiver IF channel (i.e. 40 kc/s at 6dB) and connection is made to SKT4 (marked "IF3").

The 6AU6 is strapped as a triode and fed from the anode of the last 5.2 Mc/s Amplifier via C52.

FM Channel, AVC and Meter Circuit.

The FM Channel employs a 6AU6 high-slope pentode as Limiter (V9) and a 6AL5 (V10) as a Foster Seeley Discriminator. The Limiter is fed from the final 5.2 Mc/s Amplifier via C55 and provision is made (JK1) for measuring the grid current under signal conditions. The Discriminator can handle deviations of up to 40 kc/s with negligible distortion and incorporates a normal de-emphasis circuit (R47/C64).

Audio from the Discriminator (and from the AM Channel) is taken to S4a which selects the appropriate output and routes it via C65 to the AF GAIN control RV2. Since neither Detector nor Discriminator output is blocked until C65, DC outputs are also present at S4a. These voltages are applied via the switch and R48 to the grid of the Meter Control Valve V15B ($\frac{1}{2}$ 12AU7). In the case of AM signals the voltage applied is proportional to the strength of the carrier being received while on FM it is dependent on the amount of mistuning.

The Meter Control Valve is wired as a cathode follower and has a very sensitive meter connected from a point in the cathode circuit to the slider of a potentiometer which forms part of a voltage divider across the main HT rail. The meter circuit is in fact a bridge which is balanced in the AM position of the MODE switch by adjustment of the pre-set control RV3. This positions the meter needle coincident with the zero of the carrier level scale under "no-signal" conditions. On receipt of a signal, the negative voltage developed across R33 and applied to the grid of V15B causes the bridge to become unbalanced due to the reduction in cathode voltage. The meter reading advances by an amount proportional to the voltage applied to the grid and an indication of relative signal strength is obtained. The meter can of course also be used as an aid to accurate tuning when receiving AM signals.

When the MODE switch is set to the FM position, the bridge is unbalanced by the operation of S4b (part of the MODE switch) which modifies the cathode connection of the meter circuit. The degree of unbalance is controlled by RV4 which is set such that in the absence of a signal, the meter needle takes up a mid-scale position. The meter now serves only as a tuning indicator and signals are tuned so that the meter needle lies on the red line which corresponds to the mid-scale position. This is the condition when the output from the Discriminator is zero as is the case when the carrier frequency coincides with the centre-frequency of the Discriminator characteristic. If the carrier frequency does not meet this condition there will be a DC voltage at S4a which, when applied to the grid of V15B will cause the meter reading to swing to the left or right depending on the direction of mistuning. In one direction the voltage is positive in the other it will be negative.

The AVC diode (V11B : $\frac{1}{2}$ 6AL5) is fed from the anode of V7 via the Limiter grid capacitor C55 and the 10pF capacitor C56. AVC is applied to V4, V5A, V6 and V7 and can be switched off by closing S2.

The AVC time constant is fixed and a delay is introduced by returning the cathode of V11B to the cathodes of the two push-pull output valves V16 and V17.

Muting Circuit. (Squelch)

Background noise, either between stations when tuning or in the absence of a carrier in single-frequency working can be eliminated by switching in the muting system which is incorporated in the post-IF section of the receiver. The system is arranged so that under "no-signal" conditions, noise voltages at the anode of the final IF Stage are fed to a Noise Amplifier and then rectified by a pair of germanium diodes. The diode voltage is applied to a Muting Control Stage which disables the 1st Audio Amplifier (V14A) and so prevents noise from appearing in the output of the receiver.

The circuit constants in the Noise Amplifier (V13 : 6AU6) are chosen so that only those noise voltages in the band above 15 kc/s are passed to the Noise Rectifier. This latter stage employs two GEX13 diodes (D3/D4) and is arranged as a voltage doubler with a positive output w.r.t. earth.

The grid return of the Muting Control Valve (V14B : $\frac{1}{2}$ 12AU7) is made up of five series-connected resistors which include the load resistor of the Noise Rectifier circuit (R111) and the grid resistor (R39) of the FM Limiter. Under signal conditions, V14B is biased to cut-off by the voltage developed at the grid of the Limiter and the 1st Audio Stage operates normally.

If the signal is tuned out however, the voltage at the grid of the Limiter is no longer maintained and the anode current of V14B increases. There is no AVC under these conditions and in consequence the IF chain operates at full gain to provide a substantial noise voltage at the diodes D3/D4. The resultant voltage developed across R111 causes the anode current of V14B to increase still further with the net result that a considerable voltage is developed across its anode resistor R52. This resistor is wired in series with the grid return of the 1st Audio Amplifier (V14A) and the voltage across it in the absence of a signal is sufficient to completely cut off this stage to prevent noise being heard in the output of the receiver. The lower end of R50 is earthed for AF voltages by the 0.1 μ F capacitor C67.

On receipt of a signal, AVC action causes the noise level to drop and the Noise Rectifier output falls rapidly as C130/C131 discharge through R111. The reduced positive bias at the grid of V14B allows its anode current to fall and so decreases the cut-off bias across R52. This action is hastened by the simultaneous production of a negative bias at the grid of the Limiter (i.e. across R39) so that recovery on receipt of a signal is virtually instantaneous.

The level at which V14B cuts off is adjustable by a pre-set control (RV5) in the cathode circuit of the Noise Amplifier and the muting circuit can be taken out of operation by the MUTING switch S6a/b.

Audio Section.

Three stages of audio amplification are employed, namely V14A ($\frac{1}{2}$ 12AU7), V15A ($\frac{1}{2}$ 12AU7) and the push-pull output stage V16/17 (2 x 6AM5). Up to 2.5 watts of audio are available at either the 2.5 or 600 Ω outputs when these are used independently and the response is level within 3dB over the range 200 c/s to 10 kc/s. The 600 Ω winding is electrostatically screened from both the primary and the other secondary. A telephone output is provided and is arranged so that the speaker output but not the 600 Ω line output is interrupted when telephones are in use. The output will give optimum results with 'phones of 2,000 Ω impedance but can be used satisfactorily with telephones of almost any impedance.

Provision is made for using the audio stages of the receiver with audio signals derived from an external source. Two terminals are provided for this purpose and can also be used to furnish a low level audio output to feed a recording channel. The AF GAIN control operates normally when the terminals are used as an input but is inoperative when feeding a recording channel.

Power Supplies.

The power supply provides outputs of 230V (HT1) and 150V (HT2) together with two 6.3V LT supplies (LT1 and LT2). Full-wave rectification is employed (V19 : 5Z4G) and the 150V supply is stabilised by V18 (VR150/30). The latter supply is used for V1, V2, V4 and V5B.

All stages are fed from the main 6.3V LT supply (LT1) with the exception of V11. This stage derives its supply from the LT2 winding which has its centre-tap returned to the junction of the divider network R113/R114. This arrangement maintains the heater of V11 a few volts above ground and ensures freedom from hum pick-up in the noise limiter circuit. LT1 has one side earthed and is also used to supply the three dial lamps and the six range indicator lamps.

Both sides of the mains input are switched and the live line is fused at 1 Amp by a standard 1 1/4" cartridge fuse. The power transformer is electrostatically screened and has taps to permit operation on 100/125V and 200/250V (40-60 c/s) AC.

Crystal Calibrator.

Scale calibration can be checked at 50 Mc/s intervals when the built-in calibrator is brought into operation by closing the CALIBRATOR switch S5. The tolerance of the calibrator crystal is 0.0015% and scale correction is achieved by means of a mechanical adjustment which shifts the cursor independently of the TUNING control.

The Crystal Oscillator (V12 : 6AM6) employs a series mode overtone circuit and is modulated at approximately 600 c/s for ease of identification of the marker signals. Modulation is applied to the grid of V12 and is derived from an N-P-N transistor (TR1 : BFY19) wired in a phase-shift circuit.

Supplies for the Calibrator Unit are obtained via PL1 from the B7G socket SKT5 on the power unit chassis and harmonic output is coupled to the aerial input circuit through C82 (6pF). The feed-through capacitor C79 serves as a test point (TP1) for use when adjusting the oscillator inductor L18.

CONSTRUCTIONAL DETAILS

Dimensions and Weight.

Width	16 3/4"	42.5 cm.
Width with rack-mounting brackets	19"	48.3 cm.
Height	8 3/4"	22.2 cm.
*Depth	13 3/8"	34.6 cm.
*Depth behind brackets (rack-mounting)	11 7/8"	30.2 cm.
Weight (standard receiver)	52 lb.	23.6 kg.
Weight (770U (Mk.II)/RM)	53 lb.	24.0 kg.
Weight (770U (Mk.II)/RM less cabinet)	44 1/2 lb.	20.2 kg.

*Excluding projections at rear of cabinet. An additional 2 1/2" (6.35 cm.) is needed for plugs, loads etc.

Cabinet.

The type of cabinet provided with the 770U (M.II) depends on the method of mounting which is to be employed. Cabinets are available for rack or surface-mounting. Both types are basically the same but the rack-mounting version has cut-outs along the leading edges of the vertical sides. These cut-outs extend approximately $\frac{1}{2}$ " back from the panel and give clearance for the two angled brackets which are attached to the rear of the panel to allow the receiver to be mounted in the rack. The brackets are provided with fixing slots which conform to the Post Office standard for racks of 19" width.

Both types of cabinet have extensive perforation to ensure adequate ventilation and suitably positioned apertures at the rear allow easy access to the aerial input socket, output terminals, pre-set controls etc. The cabinet is made of steel, suitably rust-proofed and enamelled.

Front Panel.

The front panel is an aluminium diecasting and contributes great mechanical strength to the receiver as a whole. All controls except the mechanical CURSOR SHIFT are located along the lower half of the panel and their functions are indicated on a clearly marked finger plate. The chromium-plated panel handles allow the receiver to be lifted easily and also afford protection to the panel controls when the receiver is placed in a face-down position as for example when removing the cabinet.

Chassis Assembly.

The RF Section of the receiver is housed in a screened enclosure which is mounted centrally on the rear of a steel support plate located immediately behind the panel. Two sub-chassis are disposed one on either side of the RF Unit and these carry all the IF and Power Supply circuits. The Audio Stages and Muting circuits are at the rear of the RF Unit on a third and smaller sub-chassis.

Dial and Drive Assembly.

The TUNING control, which drives a spring-loaded split-gear system with a reduction ratio of approximately 140:1 provides a convenient tuning rate on all ranges. The drive is flywheel-loaded, substantially free from backlash and ensures consistent re-setting accuracy. Total cursor travel on each range is some $12\frac{3}{4}$ " and the scales are calibrated directly in terms of frequency. A mechanical CURSOR SHIFT control allows the cursor to be set independently of the TUNING control when checking the scale against the internal crystal calibrator.

Mechanical bandspread is available in the form of a calibrated vernier scale which makes 22 complete revolutions for a full traverse of the cursor. The reading obtained from the vernier is combined with the reading on the logging scale which is found below the frequency scales on the main dial. Each range can be divided into 2200 divisions for accurate logging of specific stations or for interpolation between adjacent calibration marks on the main scale.

INSTALLATION

Unless otherwise stipulated, the 770U (Mk.II) is supplied complete with a standard cabinet in a form suitable for surface-mounting only. An interchangeable cabinet is available to special order and this has slots to clear the angled brackets which are fitted to allow the receiver to be mounted in a standard 19" rack. Receivers of the 770U (Mk.II) type supplied initially as rack-mounting units are referred to as the 770U (Mk.II)/RM. In rack-mounted installations operating at elevated temperatures it may be an advantage to remove the cabinet.

Instructions for installing the 770U (Mk.II) receiver with the Panoramic Display Unit Model EP17R will be found in the Instruction Manual for the latter unit.

Converting a Standard 770U (Mk.II) to 770U (Mk.II)/RM.

1. Remove the existing cabinet (four large screws at the rear) and store for use in the event of the receiver being required as a surface-mounting unit at a later date.
2. Place the receiver on its right-hand side and remove the two screws that hold the left-hand panel handle. An 18" screwdriver will be required for this operation.
3. Remove the two spacing washers from between the spacing pillars and the panel and store with the cabinet.
4. Unscrew the range lamp carrier strip, remove the existing captive screw and replace with the longer screw 6542P. The lamp assembly is replaced after (5) below, the fixing screw passing through the clearance hole provided in the bracket.
5. Slide one of the two angled brackets behind the outside edge of the panel and re-fit the spacing pillars and handle fixing screws.
6. Turn the receiver up the other way and repeat the operations in 2, 3 and 5 above to fit the angle bracket to the right-hand side of the panel.
7. Fit the replacement cabinet.

NB Part Nos. to be quoted when ordering rack-mounting cabinets and brackets are D3377 and D3381 respectively. The longer screw required bears the Part No. 6542P.

EXTERNAL CONNECTIONS

Mains.

The AC mains supply is connected to the socket at the rear using the connector provided with the receiver. The earthing wiper on the side of the connector should be wired to the earth pin on the supply plug.

The mains connector is a non-reversible type and is supplied ready-wired with six feet of mains lead. One end of this is left free so that the user can fit a plug of a type suitable for connection to the local mains supply. The lead is colour-coded as follows:- "Live" : RED, "Neutral" : BLACK, "Earth" : GREEN. If the existing lead proves too short it can easily be replaced with a longer length and the same code should be applied.

The receiver leaves the factory with the Voltage Selector set in the 230V position which is suitable for operation from AC supplies in the range 220-250V. For other voltages the Selector must be set as follows:-

100-125V	110V position.
200-220V	200V position.

The Voltage Selector is located on the side of the power transformer and takes the form of a three-way polarised socket together with an associated shorting plug. The Selector must be adjusted before connecting the receiver to the local AC supply.

Aerial.

The aerial feeder should be terminated with the coaxial plug provided with the receiver and then connected to the coaxial socket located above the centre aperture at the rear of the unit.

General information on aerials for use in the frequency range 150-500 Mc/s will be found in a separate publication, copies of which are available on request.

Earth.

The earth terminal should be connected to a suitable earthing point via a short heavy gauge conductor. In rack-mounted installations the terminal will normally be bonded to the frame of the rack.

IF Input. (IF1)

External converters with an output frequency of 50 Mc/s can be connected to this socket which is located at the rear of the unit. Connection is with a standard L.734 coaxial plug which is supplied with the receiver. The input impedance is closely matched to 75Ω and care should be taken to ensure that the output impedance of the external unit is of the same order.

IF1 can also be used as a low-level 50 Mc/s output.

IF Outputs. (IF2 and IF3)

Both IF2 and IF3 provide output at the 2nd IF of 5.2 Mc/s. IF2 is a low-level wideband output taken from the anode of the 2nd Mixer Stage and mainly intended for use when the receiver is used to feed an EP17R Panoramic Display Unit. The output impedance is of the order 75Ω but matching is not critical.

A cathode follower is used to provide the other 5.2 Mc/s output (IF3) which is derived from the final 5.2 Mc/s Amplifier. Maximum output at the IF3 socket is of the order 1 volt and the termination can be in any impedance between 75 and 300Ω .

Standard Belling Lee plugs (L.734) are used for connection to both outputs, IF2 being at the rear of the unit and IF3 on the front panel.

Loudspeaker.

An external loudspeaker can be connected to the two quick-release terminals which are marked "2.5 Ω ." The right-hand terminal, looking at the rear of the set is the earthy side of the output.

Suitable loudspeaker units in the Eddystone range are covered in Data Sheet No.123 a copy of which is available on request.

Line Output.

A 600Ω line output is available at the quick-release terminals labelled "600 Ω ." The output is electrostatically screened from the loudspeaker output and is for use when it is necessary to connect the receiver output to a distant listening point. If a balanced output is called for, the middle terminal (CT) should be linked to earth at the rear of the receiver.

Telephones.

The output provided for telephone use is suitable for a wide range of impedances so that almost any available pair of telephones will give satisfactory results. If optimum performance is required, telephones of 2000 Ω (total) impedance should be used. An auxiliary contact on the jack socket is arranged to interrupt the loudspeaker output (but not the line output) when telephones are in use.

AF Input.

Two quick-release terminals allow connection to external circuits when it is required to use the audio stages of the receiver for amplification of externally derived signals. The left-hand terminal is the earthy side of the input and screened lead should be used for connection.

The AF GAIN control functions normally when the receiver is used in this manner and speaker, line and telephone outputs are available as in normal operation. The MUTING switch must be at "Off" and the STANDBY switch should be set to "Standby" to avoid interference from signals received in the normal manner.

The same terminals can be used to furnish a low-level audio output for feeding a recording channel. In this case the output is unaffected by the AF GAIN control and level adjustment should be carried out in the recorder.

Limiter Grid.

Connection is by means of a standard jack plug, the sleeve of which is the earth connection. Grid current can be measured at this point or the jack plug can be shunted with a resistor (of the order 47,000 Ω) to provide a DC voltage for connection to an oscilloscope when using a sweep generator for checking the IF response.

OPERATION

CONTROL FUNCTIONS

Tuning.

This control alters the setting of the ganged tuning capacitors and the cursor on the main tuning dial. Ease of tuning is assured by the large control knob and the high reduction ratio of approximately 140:1. The dial is individually hand calibrated and is accurate to within 0.2% on all ranges.

Wavechange.

Rotates the coil turret to select the correct inductances for the range required. Range indication is given by a lamp display at the left-hand end of the frequency dial. A "Geneva" system is employed and gives positive selection of the correct range.

Gain Controls.

Two manual gain controls are provided. These are the IF GAIN which controls the 2nd 50 Mc/s IF Amplifier and the AF GAIN which controls the input to the audio section of the receiver. The latter control operates normally when the receiver is used with audio signals derived from an external source but has no effect on signals fed to an external recorder from the two AF Input terminals when these are used as a low-level output.

Signal Mode Switch.

This switch, marked "AM" "FM" brings about the circuit changes necessary for the desired type of reception.

Noise Limiter Switch.

The NOISE LIMITER switch is only operative in the "AM" position of the MODE switch. Impulse noise on AM signals will be reduced when the switch is set to the "On" position.

Standby Switch.

Applies a large negative bias to the 2nd 50 Mc/s Amplifier to desensitise the receiver on "Standby". The HT supplies remain on all stages during standby periods and the receiver functions normally immediately the switch is set to the "On" position. Retention of HT supplies in this way ensures that oscillator drift is negligible during periods when the receiver is not required but must be available for immediate use.

AVC Switch.

Provides normal AVC ON/OFF switching.

Muting Switch.

In the "Off" position of the switch a large negative bias is applied to the Noise Amplifier so rendering it inoperative. The Muting Control Valve is also disabled by breaking its cathode return. Under these conditions the 1st Audio Amplifier functions normally giving amplification to both signal and background noise.

With the switch to "On" and the pre-set MUTING LEVEL control set correctly, background noise will be eliminated during breaks in transmission and also when tuning between adjacent channels.

Calibrator Switch.

This switch is pressed to bring the built-in Crystal Calibrator into operation. Marker signals are available at 50 Mc/s intervals throughout the tuning range of the receiver.

Cursor Shift.

This is the small knurled control located above the dial aperture. It provides limited lateral movement of the cursor (independently of the TUNING control) to permit correction of scale errors when calibrating.

Mains Switch.

Double-pole switch controlling the AC mains input to the unit.

Pre-set Controls.

In addition to the main panel controls described above there are also three pre-set controls. These are located at the rear of the receiver and are adjusted with a small screwdriver. The three controls are as follows:-

Muting Level.

This control is wired in series with the cathode circuit of the Noise Amplifier and provides a means of adjusting the level at which the muting is rendered inoperative. The threshold can be set such that signals of 10 μ V will trip the muting circuit.

AM Zero.

Adjustment of this control allows the meter reading to be set to zero when it is desired to use the meter for carrier level indication during the reception of AM signals. When setting the meter adjustments, this control is always adjusted first.

Centre Zero FM.

When the MODE switch is moved to the FM position, the meter needle is electrically biased towards the centre of its traverse. The CENTRE ZERO FM control is used to set the meter needle in the dead centre of the meter scale coincident with the vertical red line. This is the correct setting when using the meter as a tuning indicator during FM reception.

TUNING INSTRUCTIONS

Preliminary.

Check that the AC mains supply is available and ascertain that a suitable aerial is connected to the socket at the rear. Connect a loudspeaker or plug in a pair of telephones and then move the MAINS and STANDBY switches to "On." Check that the dial becomes illuminated indicating that the receiver is operative and allow a short period for "warming-up".

Calibration Check.

Select the appropriate range and tune to the nearest crystal checkpoint to the intended working frequency. (Crystal checkpoints occur at 50 Mc/s intervals, this giving one checkpoint on Ranges 3, 4, 5 & 6, two checkpoints on Range 2 and three on Range 1.)

The crystal markers are amplitude modulated and can easily be identified. Press the CALIBRATOR switch and tune in the appropriate marker with the MODE switch at AM. Change to FM and then use the meter as a guide to the correct tuning point. When the tuning adjustment is completed, release the CALIBRATOR switch and then rotate the CURSOR SHIFT to position the cursor coincident with the correct calibration mark on the dial. The receiver is then ready for use and can be re-tuned to the required channel.

AM/FM Reception.

Selection of AM or FM reception is effected by the MODE switch which in addition to routing audio from the appropriate detection channel also modifies the connections to the tuning meter circuit. On AM the meter operates with a normal left-hand zero and signals are tuned for greatest deflection of the meter needle. The amount by which the needle is deflected is dependent on the strength of the received signal and the meter is scaled in terms of relative carrier level. When comparative measurements are to be made, it is recommended that the AVC is switched off and a convenient reference level is set by adjustment of the IF GAIN.

When the MODE switch is set at FM the meter functions only as a tuning indicator in which case the meter needle operates about a centre zero. In tuning across an FM transmission then the meter needle will swing away from centre as the signal is tuned in, back to centre at the correct tuning point, away from centre in the opposite direction as the signal is tuned out and finally back to centre again when the carrier lies outside the passband of the receiver.

Inter-station noise encountered when tuning on FM can be eliminated by bringing the muting circuits into operation, while impulse noise during AM reception can be reduced by switching "On" the Noise Limiter by means of the panel switch. Instructions for setting the muting level adjustment and also the meter zeroing will be found under "Adjustment of pre-set controls" which appears on the following page.

Standby.

The receiver can be desensitised at any time by means of the STANDBY switch which applies a cut-off bias to the 2nd 50 Mc/s IF Amplifier. HT supplies are retained during standby periods to limit frequency drift and the receiver functions normally immediately the switch is returned to the "On" position, i.e. dolly down.

ADJUSTMENT OF PRE-SET CONTROLS

Meter Adjustments.

The two pre-set meter zero controls are adjusted by following the procedure which is detailed below. This procedure obviates interaction between the adjustments and it will be found that the settings hold good over long periods of time.

The AM ZERO must be adjusted first. Set the MODE switch to AM, the IP GAIN to maximum and tune to the centre of any range. Terminate the aerial input socket with a 68Ω resistor and then adjust the AM ZERO so that the meter needle coincides with the zero mark at the left-hand end of the meter scale.

Leave the MODE switch at AM and tune any AM signal for maximum deflection of the meter needle. Change to FM, note the meter reading and then adjust the CENTRE ZERO FM control so that the meter needle takes up a position coincident with the red line at the centre of the meter scale.

Muting.

When the 770U (Mk.II) is employed as part of a communications link it may prove advantageous to make use of the built-in muting circuit. This will do much to relieve operator fatigue by eliminating background noise in the absence of a received carrier. A pre-set control (MUTING LEVEL) is provided for adjusting the circuit gain to suit the actual conditions under which the receiver is operated and the procedure for setting the control is as follows:-

First tune to the required signal and adjust the gain controls to give a convenient level of output. De-tune slightly to a clear channel so that the only output is background noise. Now move the MUTING switch to "On" and without touching the gain controls adjust the MUTING LEVEL control so that the noise just disappears. Tune back to the signal and check that it is of the same strength and that the receiver is effectively silenced when the distant transmitter is switched off.

The initial setting of the IF GAIN must not be disturbed once the muting adjustment has been made. Operation on a different frequency may call for a slight change in the setting of the MUTING LEVEL control.

MAINTENANCE

GENERAL

The 770U (Mk.II) receiver is suitable for continuous operation in all areas under adverse climatic conditions and should require very little in the way of maintenance over long periods of use. Normal routine maintenance schedules can be drawn up but should be restricted to such tasks as "cleaning the exterior", "checking the serviceability of external connections", "checking that full error correction is possible by use of the cursor shift", etc.

Lubrication.

The geared drive system, turret mechanism and other mechanical arrangements will not normally require attention since they are treated with a permanent lubricant during initial assembly. If additional lubrication should be thought necessary after the equipment has been in operation for a long period of time, this can be carried out with a light mineral oil suited to the temperature conditions under which the receiver is being used.

Replacing a faulty fuse.

A single fuse is fitted and is wired in series with the live side of the mains input to the power transformer. The fuseholder is located at the rear of the set and is accessible without the need for removal of the cabinet. A standard $1\frac{1}{4}$ " cartridge fuse rated at 1 Amp should be used as a replacement in the event of failure and appropriate checks should be made if the replacement fails immediately or after a short period of operation.

Changing Valves.

All valves with the exception of V1, V2, V3 and V5 are immediately accessible after removing the cabinet. V1-V3 are located in the RF Section and can be changed quite easily after taking off the top cover from the RF Unit. The cover can be removed with the Calibrator Unit in situ provided that its supply lead and output lead are freed from their terminations. V5 is located in the small screened unit on the IF chassis. A removable cover is fitted and this is retained with two 6BA screws.

Standard "CV" valve types are used throughout and no difficulty should be experienced in obtaining replacements. Direct equivalents can be used where necessary and any valve can be changed without necessitating re-alignment of the tuned circuits.

Replacing faulty bulbs.

Faulty dial bulbs can be changed quite simply after removal of the cabinet. The bulb holders are a spring fit in suitably shaped cut-outs in the support strip and are withdrawn by squeezing together and pulling away from the panel. The bulbs are standard bayonet types with a rating of 6.5V @ 0.3A.

A faulty range indicator lamp can be changed by removing the lamp assembly after taking out the knurled retaining screw located behind the scale plate. The bulbs are LES types with a rating of 6.5V @ 0.15A.

Always check on the possibility of poor contact in the holder before disposing of a suspected bulb.

Instructions for fitting a replacement cursor drive wire.

Stainless steel stranded wire of exceptional strength is used for the cursor drive and it is most unlikely that this would ever give trouble. If however a wire should break or be damaged in some way, a replacement can be obtained from Stratton & Co. by quoting reference SKK75. Fitting a new wire should present no difficulties if the instructions given below are carefully followed step by step. In the instructions, left-hand and right-hand are as viewed from the front of the receiver.

1. The first step is to remove the dial glass and scale plate to gain access to the drive assembly. Proceed as follows:-
 - (a) Free the range lamp assembly by slackening the chromium-plated retaining screw.
 - (b) Unscrew the two 4BA screws with long hexagonal heads which retain the two small side castings at the extremities of the dial aperture. The screws are accessible from the rear of the panel and can be turned by hand after slackening with a suitable spanner. Captive types are used to simplify replacement.

- (c) Slacken the four countersunk screws along the top edge of the panel and slide the dial lamp support strip towards the rear. This will free the top edge of the glass which can now be removed by lifting the bottom edge clear of the lip on the panel casting.
- (d) The scale plate is also free and can be removed by setting the cursor to its mid-travel position and "bowing" the rear cursor guide rod away from the front rod to allow the cursor to be tilted upwards away from the scale.
2. Remove the old drive wire by slackening the 8BA screws in the drive pulleys and unsoldering from the cursor carrier.
 3. Rotate the tuning control to its fully anti-clockwise position and set the cursor shift control to mid-travel.
 4. Attach one end of the new drive wire to the 8BA screw in the right-hand drive pulley. (The screw should lie at approximately 10 o'clock).
 5. Feed the wire through the pulley slot and into the groove nearest to the panel so that the wire leaves the pulley from left to right and passes under the meter.
 6. Take the wire under the cursor shift pulley and then vertically upwards and over the right-hand guide pulley.
 7. Pass the wire across the dial between the cursor guide rods and under the cursor carrier.
 8. Take the wire round the jockey pulley and then back towards the left-hand drive pulley.
 9. Hold the free end of the wire in tension and rotate the tuning control to its fully clockwise setting. This operation will wind approximately three complete turns of wire onto the right-hand drive pulley and the tension must now be maintained to prevent the wire from slipping out of the pulley grooves.
 10. Place the wire in the rear groove of the left-hand drive pulley and then increase the tension to cause the jockey pulley to take up a position approximately $\frac{1}{4}$ " from the guide rod support bracket. Tie off the wire to the 8BA screw. (2 o'clock).
 11. Rotate the tuning control to the fully anti-clockwise position and check that the wire runs smoothly onto the left-hand pulley.
 12. Replace the scale plate and dial glass.
 13. Set the cursor to the "0" mark on the logging scale and solder it to the drive wire.
 14. Check the drive for free and normal operation and then check the scale accuracy by reference to the internal Crystal Calibrator. Check the operation of the cursor shift control.
 15. Return the receiver to its cabinet.

Cleaning the dial glass.

The dial glass can be cleaned with one of the many domestic products which are available for this purpose. The glass can be removed by following the instructions given in paras 1 (a) - (c) above. The scale plate can also be cleaned if necessary, a lint-free cloth slightly moistened with warm water being ideal for the purpose. Make sure that all traces of moisture are removed before replacing the glass.

RE-ALIGNMENT

General.

In the unlikely event of a complete re-alignment being required, the instructions given in the following pages should be followed step by step in full. In the more usual case of partial re-alignment required to compensate for ageing components etc., the relevant instructions can be extracted as required. It must be stressed that alignment adjustments should not be tampered with unless there is a clear indication that alignment is in fact required and furthermore, adjustments should only be carried out by fully skilled technicians equipped with suitable test instruments. It should be noted that all trimmers and dust cores are self-locking.

Re-alignment of the 2nd IF Amplifiers.

Test Equipment Standard Signal Generator covering 5.2 Mc/s. (Modulation 30% at 400 c/s and output impedance in the range 10-75Ω).
.....
Output Meter matched to 2.5/3Ω.
Centre-zero μammeter (50-0-50μA deflection) and 0.1MΩ resistor.
(Required for Discriminator Alignment).
Small insulated trimming tool (screwdriver type).

Switch on the receiver and signal generator and allow at least half an hour to reach operating temperature. Set the receiver controls as follows:-

MODE SWITCH	"AM".	NL/AVC/MUTING	Off.
IF GAIN	Minimum.	STANDBY SWITCH	On.
AF GAIN	Maximum.			

Remove the bottom cover from the 2nd Mixer Unit and connect the output lead from the signal generator to the signal grid of V5A (pin 7). Connect the output meter to the 2.5Ω terminals at the rear, check the generator calibration against a reliable frequency standard and then tune it accurately to 5.2 Mc/s.

Set the attenuator for a suitable reading on the output meter and then adjust the cores in T6, T8 and T9 to their "outer" peak (i.e. the one which occurs with the core nearest to the trimming aperture). The top core in each case is the one which tunes the secondary winding and under no circumstances should the cores be set to the "inner" peak since this will upset the bandwidth of the amplifier.

On completion of the adjustments, the sensitivity of the 2nd IF Stages can be checked from the grid of the 2nd Mixer Stage. A figure of the order 350μV for an output of 50mW should be obtained (loudspeaker disconnected). If the sensitivity appears to be on the low side, transfer the generator to the grids of V6 and V7 and determine the stage by stage sensitivity. The grid connection is pin 1 in each case and typical sensitivity figures are as follows:-

Generator applied at grid of V6	4mV for 50mW output.
Generator applied at grid of V7	150mV for 50mW output.

The audio sensitivity should be checked if the sensitivity from the grid of V7 is lower than the figure quoted above. An AF signal (at 1,000 c/s) can be introduced at the AF Input terminals at the rear and should reveal a sensitivity of 200mV for 50mW output with the loudspeaker disconnected and the AF GAIN control set to maximum.

This completes alignment of the "AM" channel and adjustment can now be carried out on the "FM" channel.

Discriminator Alignment.

All the controls should be left as for IF alignment with the exception of the MODE switch which should be moved to the "FM" position.

The signal generator is adjusted to give an unmodulated output of the order one volt at 5.2 Mc/s (checked against an accurate standard) and is connected via a 0.01 μ F capacitor to the grid (pin 1) of the FM Limiter V9. The centre-zero μ Ammeter is used as an indication of Discriminator output and is connected from the junction of R45 and R46 to chassis via a 0.1M Ω isolating resistor.

Adjustment is quite straightforward and is carried out as follows. Set the secondary (top) core of the Discriminator Transformer (T10) so that it is flush with the top of the screening can and then adjust the primary core for maximum deflection on the meter. The secondary core controls the centre frequency of the characteristic and is now trimmed for zero reading on the meter. This adjustment should be made very carefully and should be followed by a check on the overall linearity of the characteristic. Any non-linearity which may be observed when the generator is detuned by equal amounts to either side of the centre frequency can be corrected by adjusting the primary core in the appropriate direction. The change in core position should be very small and if excessive trimming is required it may be best to replace V10 and repeat the adjustments again.

NOTE If the receiver forms part of the EPR25 Panoramic Display Installation, the EP17R Display Unit can be used for visual alignment of the 5.2 Mc/s Stages. Instructions will be found in the Manual supplied with the Display Unit.

Re-alignment of the 1st IF Amplifiers and 2nd Oscillator.

Test Equipment Standard Signal Generator covering 50 Mc/s and 180 Mc/s. (Modulation 30% at 400 c/s and output impedance 75 Ω).
Output Meter matched to 2.5/3 Ω .
Small insulated trimming tool (screwdriver type).

Switch on the receiver and signal generator and allow at least half an hour to reach operating temperature. Set the receiver controls as for alignment of the 5.2 Mc/s Stages but with the IF GAIN control at maximum. The MODE switch should be at "AM."

Check the generator calibration against a reliable frequency standard and then tune it accurately to 50 Mc/s. Terminate the output lead in a standard Belling Lee coaxial plug (Type L.734) and connect this to the "IF1" socket at the rear of the set. Arrange the generator to provide a modulated output (30% at 400 c/s) and connect the output meter to the 2.5 Ω terminals as before. Set the attenuator to provide a suitable output reading.

First align the 2nd Local Oscillator coil T7 to ensure that the oscillator is running on the correct frequency (44.8 Mc/s) for conversion of the 50 Mc/s 1st IF to the 2nd IF of 5.2 Mc/s. T7 is adjusted for a peak reading on the output meter.

Now proceed to trim the cores in the 50 Mc/s IF Transformers T2, T3, T4 and T5. Each transformer has a single core and untuned coupling winding(s). The cores should all be set to the peak which occurs nearest to the top of the screening can. T4 and T5 are located on the main IF chassis and are therefore easily adjusted from the top. The other two transformers are mounted on a small sub-chassis inside the screened RF compartment and are accessible through an aperture in the underside.

The overall IF sensitivity can now be checked with the generator still connected at the "IF1" input socket. A figure of the order 2.5 μ V should be obtained for an output of 50mW with the loudspeaker disconnected. Sensitivity from the grid of the pentode amplifier (V4, pin 1) is approximately 200 μ V.

The remaining 50 Mc/s IF Transformer T1 is the one in the output of the 1st Mixer Stage (D1). Direct connection is not permissible and the adjustment is therefore carried out by tuning the receiver to 180 Mc/s on Range 6, injecting a signal on this frequency at the aerial input socket and aligning on this signal after conversion to 50 Mc/s in the 1st Mixer Stage. The top cover must be removed from the RF Section to gain access to T1 which is mounted on the side of the gang assembly.

Re-alignment of the RF Section.

Test Equipment	Standard Signal Generator covering the range 150-500 Mc/s. (Modulation 30% at 400 c/s and output impedance closely matched to 75Ω). Crystal controlled harmonic generator providing markers at 10 Mc/s intervals throughout the range 150-500 Mc/s. Output Meter matched to 2.5/3Ω. Small insulated trimming tool (screwdriver type with metal tip).
-------------------------	---

The first step in this phase of the alignment procedure is to check the accuracy of the dial calibration to determine whether re-alignment of the 1st Local Oscillator is necessary. The receiver should be set up as for normal reception with the MODE switch at "FM" so that the built-in tuning meter can be used as an indication of correct tuning. The meter is more sensitive in this position than at "AM" and in any case it is doubtful whether a modulated generator of the type required would be readily to hand.

Arrange the harmonic generator to provide 10 Mc/s marker signals and connect its output lead to the aerial input socket at the rear of the receiver. Set the CURSOR SHIFT to its mid-travel position and then select each range in turn, checking the scale accuracy at 20 Mc/s intervals on the higher ranges and every 10 Mc/s on the low frequency ranges. If on completion of this check it is found that the errors are well within the range of the CURSOR SHIFT control it is in order to proceed immediately with re-alignment of the signal frequency circuits. On the other hand if re-alignment of the oscillator is necessary this must be carried out first. The relevant instructions can be extracted from the paragraphs which follow bearing in mind that adjustments should be restricted to the range or ranges on which errors are noted. Also it is most important to re-set the CURSOR SHIFT to mid-travel before commencing.

The trimmers for both oscillator and signal frequency circuits are accessible from the top of the coil turret after removal of the top cover and also the coil strip adjacent to the one to be adjusted. It will be found most convenient to combine the oscillator and signal frequency alignment in one operation, using the harmonic generator when aligning the oscillator stage and the modulated signal generator and output meter for the other circuits. This obviates the need for removing the coil strips twice and therefore saves time. The MODE switch must of course be moved to the "AM" position during signal frequency alignment.

Experience shows that adjustment of the coils is seldom necessary when carrying out re-alignment and though padding adjustments are given in the Tables which follow, this is only for the sake of completeness. In point of fact, the only time when adjustment of the coils is likely to be required is when a coil strip has been changed. The majority of the coils are wound on solid polystyrene formers and adjustment is effected by altering the turn spacing. In most cases it will be found that only very minor adjustment of the trimmer is all that is required to bring the appropriate circuit exactly into alignment.

Adjustments should be carried out at the frequencies listed in the Tables below, normal tracking procedure being employed on all ranges except Range 1. On this range there is no trimmer on the Mixer circuit and the aerial input circuit is different from that used on the other ranges. The trimmer in the Aerial section of the Range 1 strip is adjusted for best image performance and not for maximum signal as are the trimmers on the other five ranges.

To adjust the Range 1 trimmer (C93), the receiver is tuned to 400 Mc/s and the generator to the image frequency (twice the 1st IF below the signal frequency) i.e. 300 Mc/s. C93 is then set for minimum signal as indicated on the output meter.

OSCILLATOR ALIGNMENT FREQUENCIES AND ADJUSTMENTS

Range	Trimming Frequency	Trimmer	Padding Frequency	Coil
1	500 Mc/s	C95	400 Mc/s	L2
2	400 Mc/s	C99	330 Mc/s	L5
3	330 Mc/s	C103	270 Mc/s	L8
4	270 Mc/s	C108	220 Mc/s	L11
5	220 Mc/s	C114	180 Mc/s	L14
6	180 Mc/s	C120	150 Mc/s	L17

RF/MIXER ALIGNMENT FREQUENCIES AND ADJUSTMENTS

Range	Trimmer			Coil		
	Freq.	Aerial	Mixer	Freq.	Aerial	Mixer
1	500 Mc/s	†	-	400 Mc/s	-	L1
2	400 Mc/s	C96	C98	330 Mc/s	L3	L4
3	330 Mc/s	C100	C102	270 Mc/s	L6	L7
4	270 Mc/s	C105	C107	220 Mc/s	L9	L10
5	220 Mc/s	C110	C112	180 Mc/s	L12	L13
6	180 Mc/s	C116	C118	150 Mc/s	L15	L16

†C93. Adjust as described in text above.

The overall sensitivity on completion should be of the order 10 μ V or better for a s/n ratio of 15dB on all ranges.

APPENDIX "A"
VOLTAGE ANALYSIS

The following "Table of Voltage Values" will prove useful in the event of the receiver developing a fault which makes it necessary to carry out voltage checks. All readings are typical and were taken with a meter having a sensitivity of 20,000Ω/V. A nominal tolerance of 10% will apply to readings taken with a meter of this sensitivity and the tolerance should be increased accordingly if a meter of lower sensitivity is employed. Readings are quoted on the basis of an applied AC mains supply of 240V with the Voltage Selector in the 230V position. Checks should be made under "no-signal" conditions with the receiver controls set as follows:-

MODE SWITCH "AM".	MUTING SWITCH On.
WAVECHANGE Range 6.	MUTING LEVEL Max c/wise.
IF/AF GAINS Maximum.	STANDBY On.

Ref	Anode		Screen		Cathode		Note
	Pin	Reading	Pin	Reading	Pin	Reading	
V1	5	126V	-	-	2	0.45V	NOTE 1.
V2	1/7	34V	-	-	5	1.0V	NOTE 2.
V3A	1	157V	-	-	3	1.4V	
V3B	6	210V	-	-	8	1.7V	
V4	5	149V	6	147V	2/7	1.5V	NOTE 3.
V5A	6	220V	-	-	8	4.0V	
V5B	1	30V	-	-	3	-	
V6	5	205V	6	80V	7	0.8V	
V7	5	205V	6	80V	7	0.8V	
V8	5	74V	6	74V	7	0.4V	
V9	5	28V	6	28V	7	-	
V10	-	-	-	-	-	-	
V11A	7	-	-	-	1	-	
V11B	2	-	-	-	5	12.2V	
V12	5	210V	7	98V	2	-	NOTE 4.
V13	5	215V	6	188V	7	23.0V	
V14A	6	220V	-	-	8	27.0V	
V14B	1	6.5V	-	-	3	-	
V15A	6	162V	-	-	8	68.0V	
V15B	1	121V	-	-	3	3.3V	
V16	5	223V	7	218V	2	12.2V	
V17	5	223V	7	218V	2	12.2V	
V18	5	150V	-	-	2	-	
V19	4/6	250V AC	-	-	8	265V	

- NOTE 1. Anode voltage is measured on screw at front left-hand corner of T1. Cathode voltage is measured on valve base.
- NOTE 2. Anode voltage is measured on screw to front of oscillator valve. Cathode voltage is measured beneath valve base, approaching close to gang spindle.
- NOTE 3. Readings quoted are with IF GAIN at maximum. Cathode voltage becomes 8V with IF GAIN at minimum. Cathode voltage with IF GAIN at maximum and the STANDBY switch "up" is 38V.
- NOTE 4. Figures quoted are with CALIBRATOR switch pressed. Transistor voltages are Base 1.23V, Emitter 0.75V and Collector 7.6V.

APPENDIX "B"

LIST OF COMPONENT VALUES, TOLERANCES AND RATINGS

Capacitors.

Ref	Value	Type	Tolerance	Wkg. V.
C1 } C2 } C3 }	2-8pF	3-gang split-stator variable	-	-
C4	15pF	Mica (integral with gang)	-	-
C5	15pF	Mica (integral with gang)	-	-
C6	91pF	Tubular Ceramic Feed Through	20%	750V
C7	10pF	Tubular Ceramic	10%	750V
C7a	0.5pF	Tubular Ceramic	0.25pF	750V
C8	6pF	Silvered Mica	10%	350V
C9	50pF	Tubular Ceramic	10%	750V
C10	10pF*	Tubular Ceramic	10%	750V
C11	20pF	Tubular Ceramic	10%	750V
C12	500pF	Metallised Paper	20%	600V
C13	500pF	Metallised Paper	20%	600V
C14	500pF	Metallised Paper	20%	600V
C15	500pF	Metallised Paper	20%	600V
C16	500pF	Metallised Paper	20%	600V
C17	91pF	Tubular Ceramic Feed Through	20%	750V
C18	500pF	Metallised Paper	20%	600V
C19	500pF	Metallised Paper	20%	600V
C20	0.003 μ F	Metallised Paper	20%	350V
C21	500pF	Metallised Paper	20%	600V
C22	500pF	Metallised Paper	20%	600V
C23	91pF	Tubular Ceramic Feed Through	20%	750V
C24	500pF	Metallised Paper	20%	600V
C25	91pF	Tubular Ceramic Feed Through	20%	750V
C26	0.01 μ F	Polyester	10%	400V
C26a	91pF	Tubular Ceramic Feed Through	20%	750V
C27	50pF	Tubular Ceramic	10%	750V
C28	100pF	Polystyrene	5%	125V
C29	100pF	Polystyrene	5%	125V
C30	91pF	Tubular Ceramic Feed Through	20%	750V
C31	0.01 μ F	Metallised Paper	20%	200V
C32	500pF	Metallised Paper	20%	600V
C33	1pF	Tubular Ceramic	+0.5 -0pF	750V
C34	20pF	Silvered Mica	10%	350V*
C35	50pF	Silvered Mica	10%	350V
C36	50pF	Tubular Ceramic	10%	750V
C37	0.01 μ F	Polyester	10%	400V
C38	0.01 μ F	Polyester	10%	400V
C39	100pF	Polystyrene	5%	125V
C40	100pF	Polystyrene	5%	125V
C41	0.01 μ F	Metallised Paper	20%	200V
C42	0.01 μ F	Metallised Paper	20%	200V
C43	0.01 μ F	Metallised Paper	20%	200V
C44	0.01 μ F	Polyester	10%	400V

*Nominal value.

Ref	Value	Type	Tolerance	Wkg. V.
C45	0.01 μ F	Polyester	10%	400V
C46	100pF	Polystyrene	5%	125V
C47	100pF	Polystyrene	5%	125V
C48	100pF	Tubular Ceramic	10%	750V
C49	100pF	Tubular Ceramic	10%	750V
C50	0.01 μ F	Metallised Paper	20%	200V
C51	0.1 μ F	Polyester	10%	400V
C52	50pF	Tubular Ceramic	10%	750V
C53	0.01 μ F	Polyester	10%	400V
C54	0.01 μ F	Metallised Paper	20%	200V
C55	50pF	Tubular Ceramic	10%	750V
C56	10pF	Tubular Ceramic	10%	750V
C57	0.01 μ F	Metallised Paper	20%	200V
C58	0.01 μ F	Metallised Paper	20%	200V
C59	0.01 μ F	Metallised Paper	20%	200V
C60	100pF	Polystyrene	5%	125V
C61	50pF	Tubular Ceramic	10%	750V
C62	50pF	Polystyrene	5%	125V
C63	100pF	Tubular Ceramic	10%	750V
C64	100pF	Tubular Ceramic	10%	750V
C65	0.01 μ F	Metallised Paper	20%	200V
C66	0.01 μ F	Metallised Paper	20%	200V
C67	0.1 μ F	Polyester	10%	400V
C68	5 μ F	Tubular Electrolytic	+100% -20%	50V
C69	4 μ F	Tubular Electrolytic	+100% -20%	275V
C70	0.01 μ F	Polyester	10%	400V
C71	0.01 μ F	Polyester	10%	400V
C72	0.01 μ F	Polyester	10%	400V
C73	30 μ F	Tubular Electrolytic	+100% -20%	15V
C74	0.01 μ F	Metallised Paper	20%	200V
C75	0.01 μ F	Polyester	10%	400V
C76	500pF	Metallised Paper	20%	600V
C77	0.01 μ F	Polyester	10%	400V
C78	100pF	Tubular Ceramic	10%	750V
C79	0.0015 μ F	Tubular Ceramic Feed Through	20%	500V
C80	40pF	Tubular Ceramic	10%	750V
C81	20pF	Tubular Ceramic	10%	750V
C82	6pF	Tubular Ceramic	10%	750V
C83	0.001 μ F	Tubular Ceramic	+50% -25%	750V
C84	0.001 μ F	Tubular Ceramic	+50% -25%	750V
C85	10 μ F	Tantalum Electrolytic	20%	25V
C86	2 μ F	Tubular Electrolytic	+100% -20%	12V
C87	2 μ F	Tubular Electrolytic	+100% -20%	12V
C88	0.01 μ F	Metallised Paper	20%	200V
C89	0.01 μ F	Metallised Paper	20%	200V
C90	0.01 μ F	Metallised Paper	20%	200V
C91	0.01 μ F	Metallised Paper	20%	200V
C92	20pF	Tubular Ceramic	10%	750V
C93	1-5pF	Air Trimmer	-	-
C94	20pF	Tubular Ceramic	10%	750V

Ref	Value	Type	Tolerance	Wkg. V.
C95	1-5pF	Air Trimmer	-	-
C96	2-12pF	Air Trimmer	-	-
C97	100pF	Tubular Ceramic	10%	750V
C98	1-5pF	Air Trimmer	-	-
C99	1-5pF	Air Trimmer	-	-
C100	2-12pF	Air Trimmer	-	-
C101	100pF	Tubular Ceramic	10%	750V
C102	1-5pF	Air Trimmer	-	-
C103	1-5pF	Air Trimmer	-	-
C104	25pF	Silvered Mica	5%	350V
C105	2-12pF	Air Trimmer	-	-
C106	100pF	Tubular Ceramic	10%	750V
C107	1-5pF	Air Trimmer	-	-
C108	1-5pF	Air Trimmer	-	-
C109	25pF	Silvered Mica	5%	350V
C110	2-12pF	Air Trimmer	-	-
C111	100pF	Tubular Ceramic	10%	750V
C112	1-5pF	Air Trimmer	-	-
C113	1pF	Tubular Ceramic	0.25pF	750V
C114	1-5pF	Air Trimmer	-	-
C115	25pF	Silvered Mica	5%	350V
C116	2-12pF	Air Trimmer	-	-
C117	100pF	Tubular Ceramic	10%	750V
C118	1-5pF	Air Trimmer	-	-
C119	1pF	Tubular Ceramic	0.25pF	750V
C120	1-5pF	Air Trimmer	-	-
C121	25pF	Silvered Mica	5%	350V
C122	0.01μF	Metallised Paper	20%	200V
C123	0.01μF	Metallised Paper	20%	200V
C124	0.01μF	Metallised Paper	20%	200V
C125	10pF	Tubular Ceramic	10%	750V
C126	50pF	Tubular Ceramic	10%	750V
C127	0.01μF	Metallised Paper	20%	200V
C128	100pF	Tubular Ceramic	10%	750V
C129	0.005μF	Metallised Paper	20%	250V
C130	0.005μF	Metallised Paper	20%	250V
C131	0.005μF	Metallised Paper	20%	250V
C132	500pF	Metallised Paper	20%	600V
C133	0.01μF	Metallised Paper	20%	200V
C134	50μF	Tubular Electrolytic	+50% -20%	450V
C135	50μF	Tubular Electrolytic	+50% -20%	450V
C136	20pF	Tubular Ceramic	10%	750V
C137	20pF	Tubular Ceramic	10%	750V
C138	20pF	Tubular Ceramic	10%	750V
C139	20pF	Tubular Ceramic	10%	750V
C140	500pF	Metallised Paper	20%	600V
C141	91pF	Tubular Ceramic Feed Through	20%	750V
C142	500pF	Metallised Paper	20%	600V
C143	91pF	Tubular Ceramic Feed Through	20%	750V
C144	500pF	Metallised Paper	20%	600V

Ref	Value	Type	Tolerance	Wkg. V.
C145	0.01 μ F	Metallised Paper	20%	200V
C146	0.01 μ F	Metallised Paper	20%	200V
C147	0.01 μ F	Metallised Paper	20%	200V
C148	0.01 μ F	Metallised Paper	20%	200V

Resistors.

Ref	Value	Tol.	Rating	Ref	Value	Tol.	Rating
R1	3,300 Ω	10%	1 watt	R40	0.1M Ω	10%	$\frac{1}{2}$ watt
R2	6,800 Ω	10%	1 watt	R41	68 Ω	5%	$\frac{1}{2}$ watt
R3	22,000 Ω	10%	1 watt	R42	22,000 Ω	10%	$\frac{1}{2}$ watt
R4	150 Ω	10%	1 watt	R43	22,000 Ω	10%	$\frac{1}{2}$ watt
R5	2,200 Ω	10%	1 watt	R44	0.1M Ω	10%	$\frac{1}{2}$ watt
R6	6,800 Ω	10%	1 watt	R45	0.1M Ω	5%	$\frac{1}{2}$ watt
R7	200 Ω	10%	1 watt	R46	0.1M Ω	5%	$\frac{1}{2}$ watt
R8	200 Ω	10%	1 watt	R47	22,000 Ω	10%	$\frac{1}{2}$ watt
R9	10,000 Ω	10%	1 watt	R48	1 M Ω	10%	$\frac{1}{2}$ watt
R10	2,200 Ω	10%	$\frac{1}{2}$ watt	R49	0.82M Ω	10%	$\frac{1}{2}$ watt
R11	1,000 Ω	10%	$\frac{1}{2}$ watt	R50	1M Ω	10%	$\frac{1}{2}$ watt
R12	33,000 Ω	10%	1 watt	R51	3,300 Ω	10%	$\frac{1}{2}$ watt
R13	0.27M Ω	10%	$\frac{1}{2}$ watt	R52	0.27M Ω	10%	$\frac{1}{2}$ watt
R14	47,000 Ω	10%	1 watt	R53	6,800 Ω	10%	$\frac{1}{2}$ watt
R15	200 Ω	10%	1 watt	R54	27,000 Ω	10%	$\frac{1}{2}$ watt
R16	0.27M Ω	10%	1 watt	R55	0.1M Ω	10%	1 watt
R17	0.1M Ω	10%	1 watt	R56	47,000 Ω	10%	1 watt
R18	0.1M Ω	10%	1 watt	R57	47,000 Ω	10%	1 watt
R19	2,200 Ω	10%	1 watt	R58	0.47M Ω	10%	1 watt
R20	82 Ω	10%	$\frac{1}{2}$ watt	R59	3,300 Ω	10%	1 watt
R21	2,200 Ω	10%	1 watt	R60	47,000 Ω	10%	1 watt
R22	0.1M Ω	10%	1 watt	R61	1.8M Ω	10%	1 watt
R23	22,000 Ω	10%	1 watt	R62	0.47M Ω	10%	1 watt
R24	10,000 Ω	10%	1 watt	R63	0.47M Ω	10%	1 watt
R25	0.27M Ω	10%	1 watt	R64	1.8M Ω	10%	1 watt
R26	47,000 Ω	10%	1 watt	R65	620 Ω	10%	1 watt
R27	2,200 Ω	10%	1 watt	R66	4,700 Ω	10%	1 watt
R28	68 Ω	5%	1 watt	R67	4,700 Ω	10%	1 watt
R29	0.27M Ω	10%	1 watt	R68	47,000 Ω	10%	1 watt
R30	47,000 Ω	10%	1 watt	R69	4,700 Ω	10%	1 watt
R31	2,200 Ω	10%	1 watt	R70	100 Ω	10%	$\frac{1}{2}$ watt
R32	68 Ω	5%	1 watt	R71	22,000 Ω	10%	1 watt
R33	0.1M Ω	10%	1 watt	R72	22,000 Ω	10%	1 watt
R34	0.1M Ω	10%	1 watt	R73	33,000 Ω	10%	1 watt
R35	1M Ω	10%	1 watt	R74	2,200 Ω	10%	1 watt
R36	2M Ω	10%	1 watt	R75	68,000 Ω	10%	1 watt
R37	0.27M Ω	10%	1 watt	R76	0.1M Ω	10%	1 watt
R38	0.27M Ω	10%	1 watt	R77	22,000 Ω	10%	1 watt
R39	0.27M Ω	10%	1 watt	R78	1,000 Ω	10%	1 watt
				R79	4,700 Ω	10%	1 watt

Ref	Value	Tol.	Rating
R80	10,000Ω	10%	$\frac{1}{2}$ watt
R81	10,000Ω	10%	$\frac{1}{2}$ watt
R82	10,000Ω	10%	$\frac{1}{2}$ watt
R83	47,000Ω	10%	$\frac{1}{2}$ watt
R84	4,700Ω	10%	$\frac{1}{2}$ watt
R85	47,000Ω	10%	1 watt
R86	3.3MΩ	10%	$\frac{1}{2}$ watt
R87	68Ω	5%	$\frac{1}{2}$ watt
R88	68Ω	5%	$\frac{1}{2}$ watt
R89	10,000Ω	10%	$\frac{1}{2}$ watt
R90	68Ω	5%	$\frac{1}{2}$ watt
R91	6,800Ω	10%	$\frac{1}{2}$ watt
R92	68Ω	5%	$\frac{1}{2}$ watt
R93	10,000Ω	10%	$\frac{1}{2}$ watt
R94	68Ω	5%	$\frac{1}{2}$ watt
R95	10,000Ω	10%	$\frac{1}{2}$ watt
R96	68Ω	5%	$\frac{1}{2}$ watt
R97	10,000Ω	10%	$\frac{1}{2}$ watt
R98	47,000Ω	10%	1 watt
R99	330Ω	10%	$\frac{1}{2}$ watt
R100	1,000Ω	10%	$\frac{1}{2}$ watt
R101	22,000Ω	10%	$\frac{1}{2}$ watt
R102	0.47MΩ	10%	$\frac{1}{2}$ watt
R103	0.47MΩ	10%	$\frac{1}{2}$ watt
R104	1MΩ	10%	$\frac{1}{2}$ watt
R105	1MΩ	10%	$\frac{1}{2}$ watt
R106	0.27MΩ	10%	$\frac{1}{2}$ watt
R107	47,000Ω	10%	1 watt
R108	150Ω	10%	$\frac{1}{2}$ watt
R109	10,000Ω	10%	$\frac{1}{2}$ watt

Ref	Value	Tol.	Rating
R110	1MΩ	10%	$\frac{1}{2}$ watt
R111	1MΩ	10%	$\frac{1}{2}$ watt
R112	0.47MΩ	10%	$\frac{1}{2}$ watt
R113	0.27MΩ	10%	1 watt
R114	6,800Ω	10%	$\frac{1}{2}$ watt
R115*	1,800Ω	5%	6 watt
	*wirewound.		

Potentiometers.

Ref	Value	Type
RV1	10,000Ω	Carbon
RV2	0.5MΩ	Carbon
RV3	600Ω	Wirewound
RV4	600Ω	Wirewound
RV5	5,000Ω	Wirewound

ERRATUM

R99 should read "680Ω" both in the list above and on the circuit diagram.

APPENDIX "C"

SPARES

The following list details all major spares for the Model 770U (Mk.II) receiver. Spares should be ordered by quoting the Circuit Ref. (where applicable), the written description given in the list and the Part No. in the right-hand column. The Serial No. of the receiver should be stated in all communications.

All orders and enquiries should be addressed to:-

Eddystone Radio Ltd., Sales and Service Dept., Alvechurch Rd., Birmingham, 31.

In cases of extreme urgency, ring PRIory 2231/4, cable EDDYSTONE Birmingham or use TELEX 33708.

Ref	Description	Part No.
	<u>RF COIL UNITS.</u> (L1-L17)	
-	Range 1 (400-500 Mc/s).	D2158A
-	Range 2 (330-400 Mc/s).	D2159
-	Range 3 (270-330 Mc/s).	D2160
-	Range 4 (220-270 Mc/s).	D2161
-	Range 5 (180-220 Mc/s).	D2162
-	Range 6 (150-180 Mc/s).	D2163
-	Coil Unit contacts.	5025P
-	Mica washer (1 required with each contact).	5153P
	<u>CHOKES AND TRANSFORMERS.</u>	
CH1	RF Amplifier heater choke.	D2153A
CH2	1st Oscillator heater choke.	D2153A
CH3	Cascode neutralising choke.	D2154
CH4	2nd Mixer heater choke.	D2153A
CH5	Range 1 RF Amplifier cathode choke.	D2156
CH6	Range 1 Oscillator anode choke.	D2156
CH7	HT smoothing choke.	D2049
CH8	Crystal Calibrator anode choke.	D2854
CH9	Crystal Calibrator cathode choke.	D2922
L18	Crystal Calibrator grid coil.	D2868
T1	1st 50 Mc/s IF Transformer (1st Mixer Transformer).	D2043
T2	2nd 50 Mc/s IF Transformer (Cascode Input Transformer).	D2044
T3	3rd 50 Mc/s IF Transformer (Cascode Output Transformer).	D2045
T4	4th 50 Mc/s IF Transformer (Buffer Input Transformer).	D2045
T5	5th 50 Mc/s IF Transformer (Buffer Output Transformer).	D2042
T6	1st 5.2 Mc/s IF Transformer.	D1906/1B
T7	2nd Local Oscillator coil.	D2046A
T8	2nd 5.2 Mc/s IF Transformer.	D1906/2B
T9	3rd 5.2 Mc/s IF Transformer.	D1906/1B
T10	5.2 Mc/s Discriminator Transformer.	D2815/1
T11	Output Transformer (600Ω CT and 2.5/30).	D1791A
T12	Power Transformer.	3937P
	<u>CRYSTALS.</u>	
XL1	50 Mc/s Style "D". (0.0015% - 25pF - 25°C.).	6284P
	<u>SWITCHES.</u>	
S1	Standby Switch (DPDT toggle type with long dolly).	4772/1PC
S2	AVC Switch (SPST toggle type).	4771PB
S3	NL Switch (SPST wafer type).	5178P
S4	Mode Switch:- Wafer (2P2W).	D3307
	Control spindle/clicker plate.	D3301
	Extension spindle.	4344/1P
S5	Calibrator Switch (DPCO push-button type).	6364P
S6	Muting Switch (DPDT toggle type).	4772PC
S7	Range Indicator Switch (wafer only, 1P6W).	4917P
S8	Mains Switch (DPDT toggle type).	4772PC

Ref	Description	Part No.
	<u>POTENTIOMETERS.</u>	
RV1	IF Gain (10,000).	4614PA
RV2	AF Gain (0.5M).	4103PB
RV3	AM Zero (5000 pre-set).	6566F
RV4	Centre-Zero FM (6000 pre-set).	6566P
RV5	Muting Level (5,000 pre-set).	6123P
	<u>PLUGS AND SOCKETS.</u>	
PL1	Calibrator Supply Plug (B7G type).	6100P
-	Standard coaxial plug (as used for Aerial Input etc.).	6079P
-	Mains plug (polarised with earth connection and 6' lead).	D2311/1
-	Telephone plug.	6567P
SKT1-4	Standard coaxial sockets (Aerial Input, IFI etc.).	6087P
SKT5	Calibrator Supply Socket (B7G type).	6086P
SKT6	Mains socket (polarised with earth contact).	D2310
JK1	Limiter grid socket.	6090P
JK2	Telephone socket.	6090P
	<u>KNOBS.</u>	
	Tuning.	5817P
	Wavechange.	5817P
	Small knobs as used for IF Gain etc.).	5816P
	<u>DRIVE ASSEMBLY.</u>	
	Main Drive Unit.	LP2242/1
	*Control spindle and bearing assembly.	4055P
	*Flywheel.	D2581
	*Screw for flywheel.	1484P
	*Stainless steel driving disc (with gears).	D1559/1
	*Condenser (output) gear.	D2077
	*Vernier gear.	D2075
	Drive pulley (cursor drive wire).	5837P
	Guide pulley (cursor drive wire).	6125P
	Jackey arm assembly with rivet and spring.	D3410
	Cursor assembly.	D3087/1
	Cursor shift mechanism (less concentric pulley)	D5233
	Cursor guide rod.	5801P
	Length of steel drive wire.	SKK75
	Vernier dial with hub.	D2250
	*Included in Main Drive Unit.	
	<u>MISCELLANEOUS.</u>	
	Calibrator Unit (less valve/crystal).	LP2882
	Chromium plated panel handles.	5826P
	Cover fixing screws.	5446PC
	Dial glass retaining strip.	6261P
	Dial lamps (6.5V @ 0.3A).	3131P
	Dial lamp holders.	6374P

Ref	Description	Part No.
	<u>MISCELLANEOUS.</u> (contd.)	
	Dust cores as used in IF Transformers.	6568P
	Finger Plate.	6610P
	Flexible coupler	D1680
	Fuse (standard cartridge type 1 $\frac{1}{4}$ " x $\frac{1}{4}$ " x 1 Amp).	6124P
	Fuseholder.	6103P
	Gang assembly (with valveholders, contacts, wiring etc.).	D2659
	Glass window.	5847P
	Range Indicator Lamps (LES 6.5V @ 0.15A).	6599P
	Range Indicator Lampholders.	6600P
	Scale plate (plain uncalibrated).	6617P
	Terminals	6102P
	Tuning Meter.	5888P
	Valveholders (special):- V1 RF Amp (Modified B9A).	D2229
	V2 1st Osc (Modified B7G).	D2228
	Valve retainer (V16/17).	D2360
	Valve screening can (B7G).	6126P
	Valve screening can (B9A).	6127P

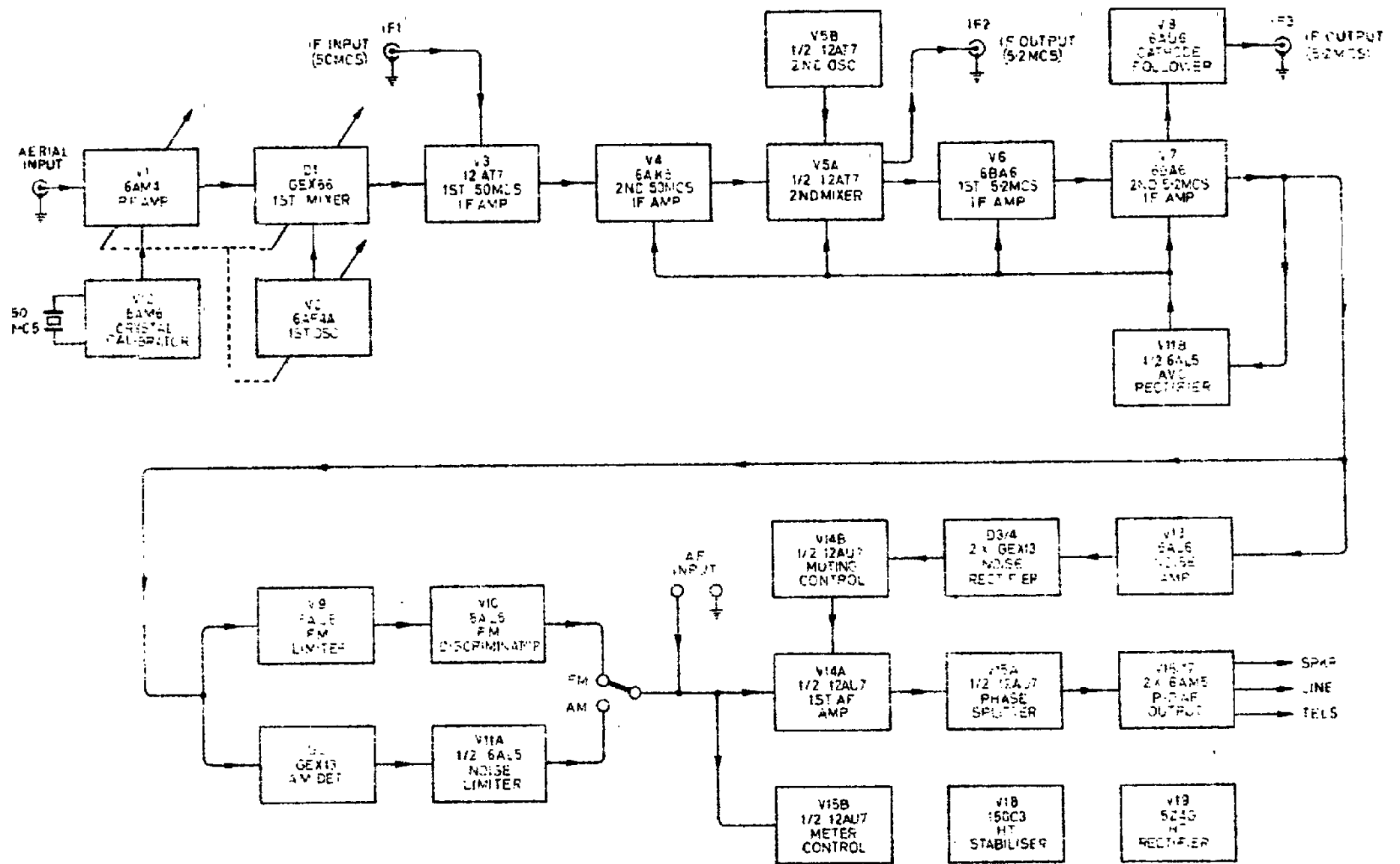
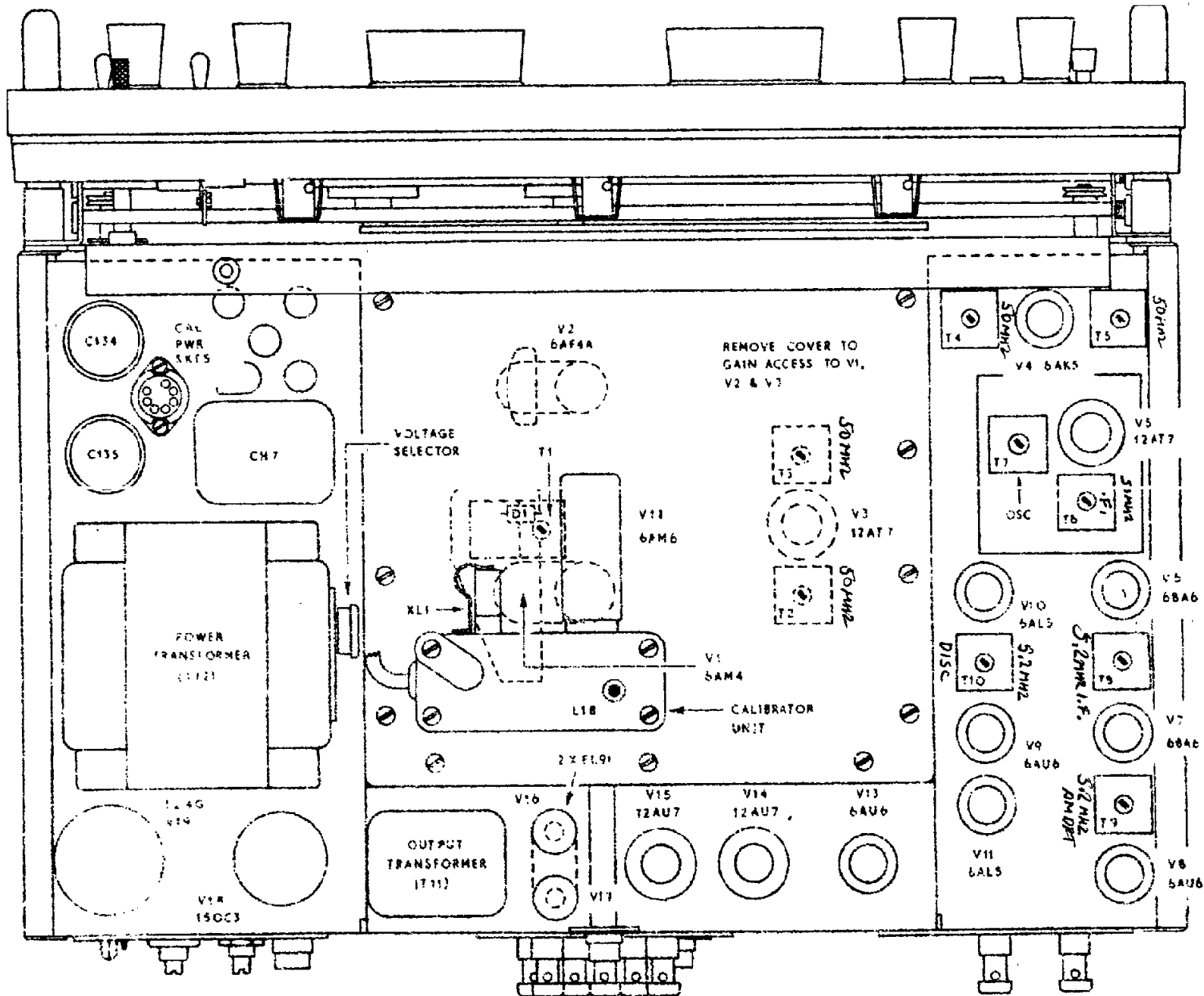

Fig. 1. Block Schematic Diagram of 770U (L3, II) Receiver.

-52-

12
13
14
15
16
17
18
19
20
21
22
23
24
25
26
27
28
29
30
31
32
33
34
35
36
37
38
39
40
41
42
43
44
45
46
47
48
49
50
51
52
53
54
55
56
57
58
59
60
61
62
63
64
65
66
67
68
69
70
71
72
73
74
75
76
77
78
79
80
81
82
83
84
85
86
87
88
89
90
91
92
93
94
95
96
97
98
99
100



-33-

UNIT 111 (11) A-001-000

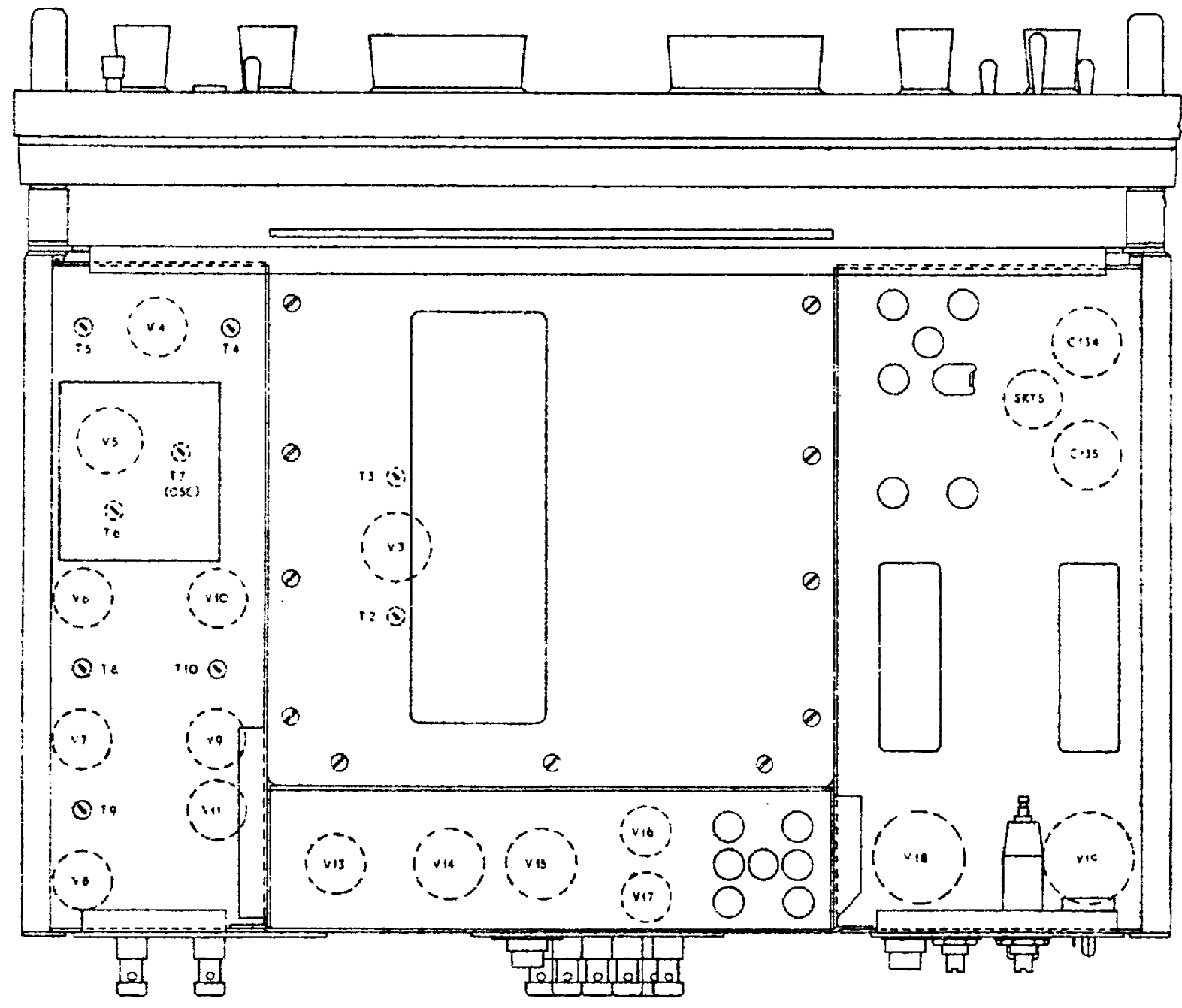

AMENDMENT SHEET NO.

Pages 23/24

Change type pe the owing capac tors to read Tubular
ap

17, 38 44, 51 17, 70 71, 72
175 177.

Page 24

Change ad μ F Circui correc

Circuit
Diagram.

change la! abo V13 to 01 AMPLIFIER

by EDD SFC RAD TD ALVECHUR AD WEST DEATH BIRMINGHAM 31

RF AMPLIFIER
1ST MIXER

1ST OSCILLATOR

1ST 50MCS AMPLIFIER

2ND 50MCS AMPLIFIER

2ND MIXER

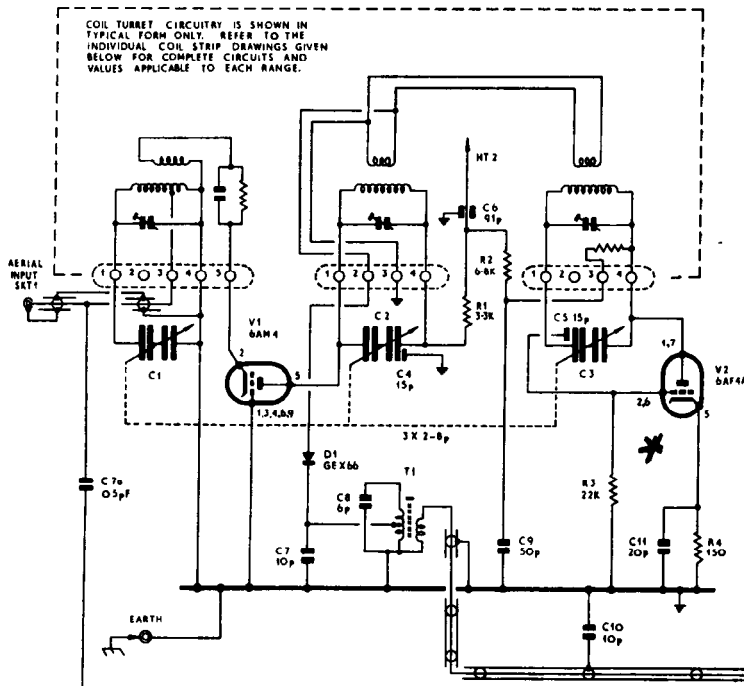

COIL TURRET CIRCUITRY IS SHOWN IN TYPICAL FORM ONLY. REFER TO THE INDIVIDUAL COIL STRIP DRAWINGS GIVEN BELOW FOR COMPLETE CIRCUITS AND VALUES APPLICABLE TO EACH RANGE.

NOTE: SRT2 CAN BE USED FOR INPUT OR OUTPUT (Z=75Ω NOM)

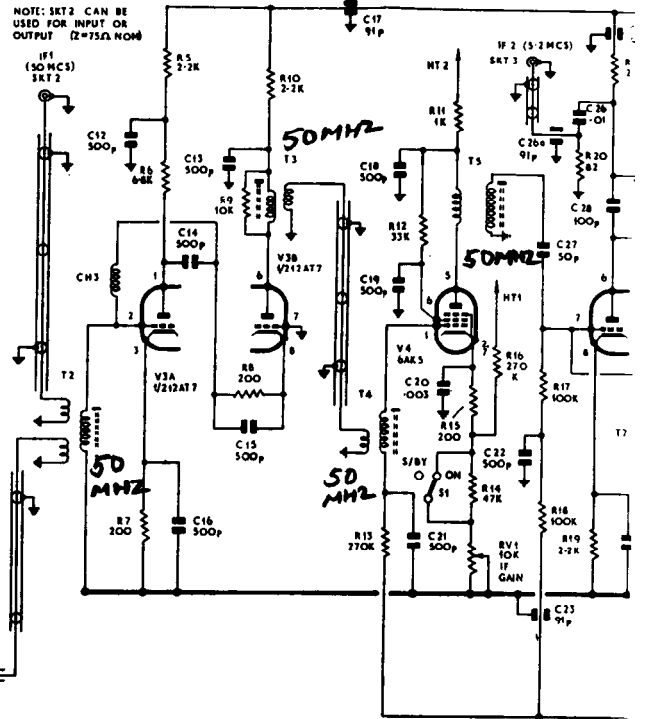

CRYSTAL CALIBRATOR

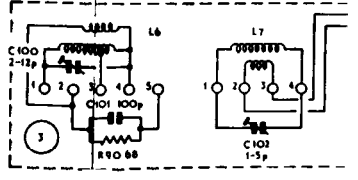
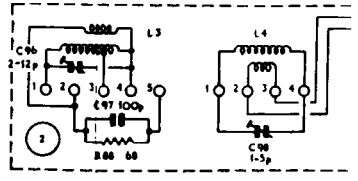
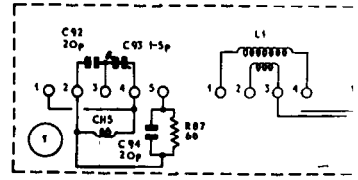
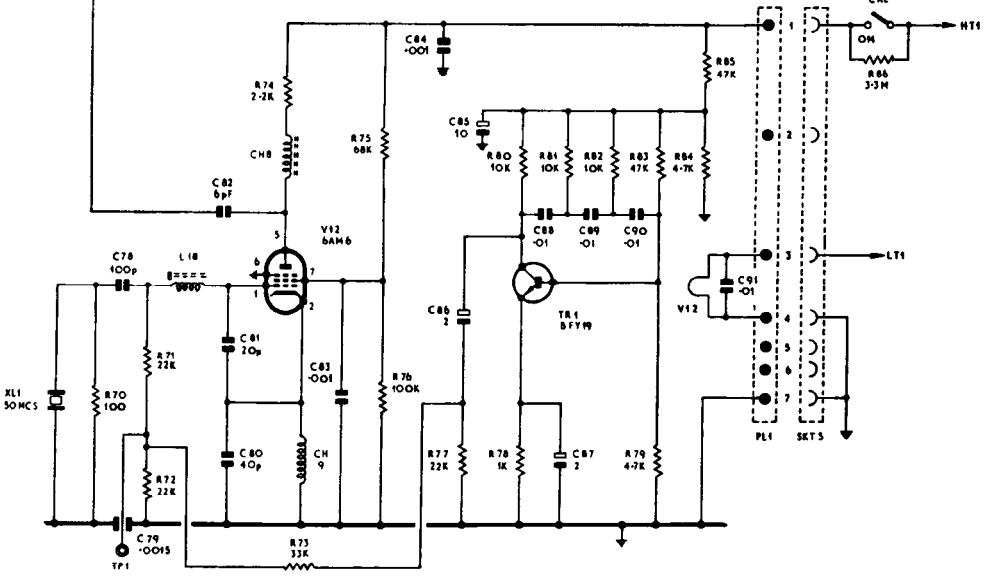

* 1ST OSCILLATOR

BANDS 1+2 OSC IS 50MHZ BELOW RF

BANDS 3,4,5,6
OSC IS 50MHZ
ABOVE RF

MODEL 770U MK II

COIL TURRET WIRING (RINGED NUMBER IND)

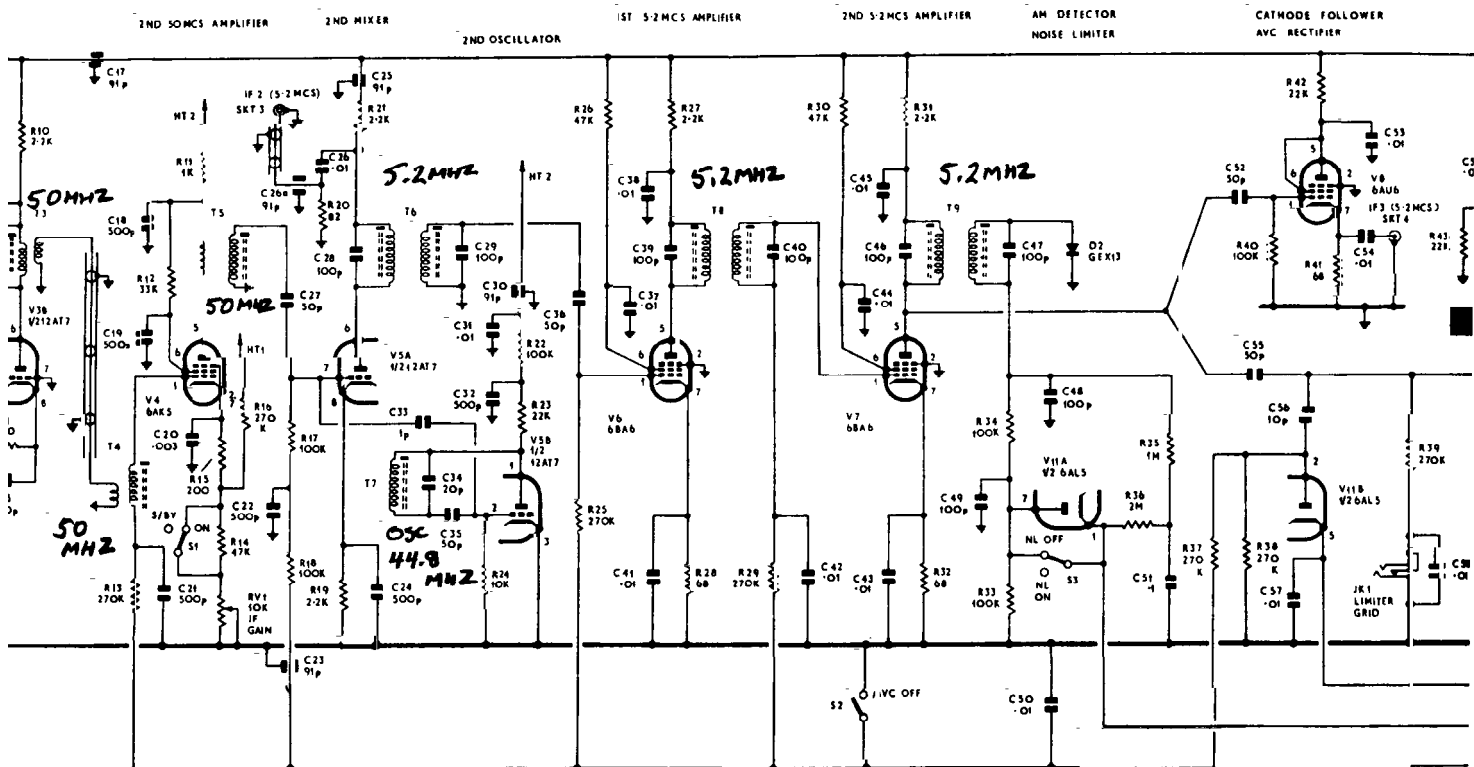

METER CONTROL

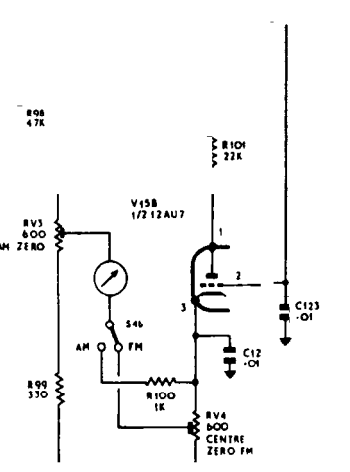
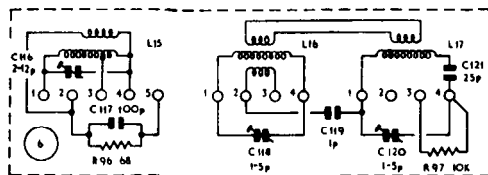
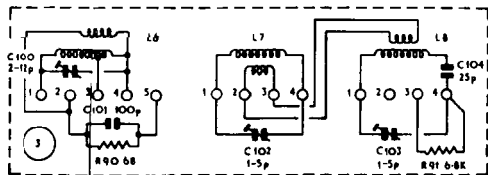
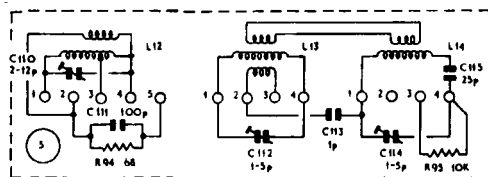
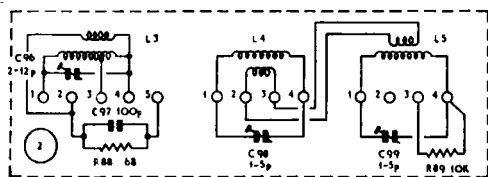
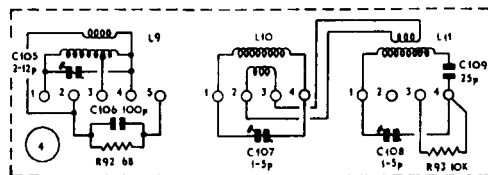
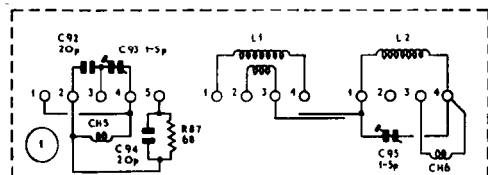

CCL TURRET WIRING (RINGED NUMBER INDICATES RANGE)

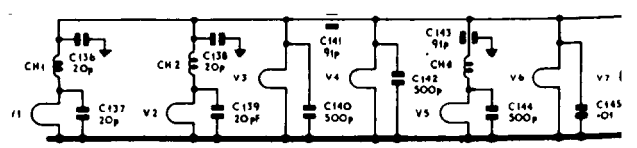

CATHODE FOLLOWER
AVC RECTIFIER

FM LIMITER

FM DISCRIMINATOR

1ST AUDIO AMP

PHASE SPLITTER

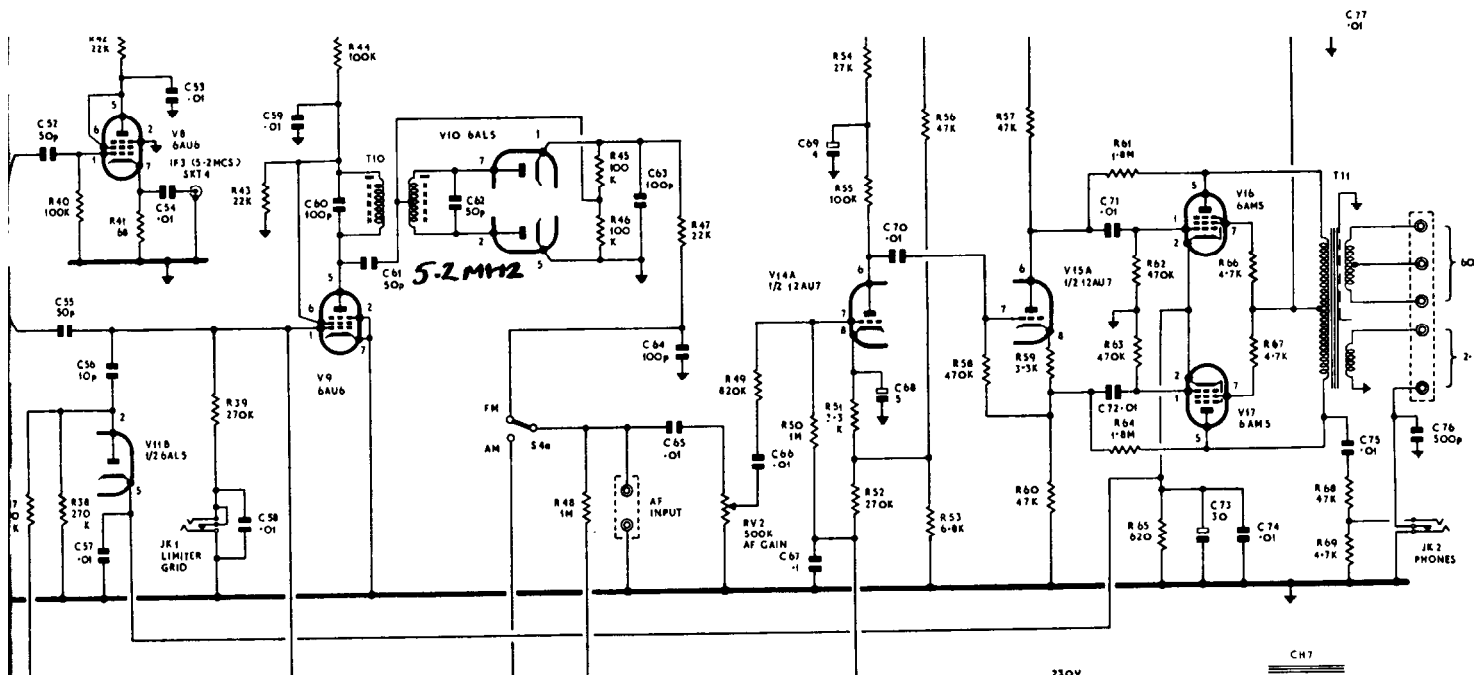

METER CONTROL

NOISE RECTIFIER

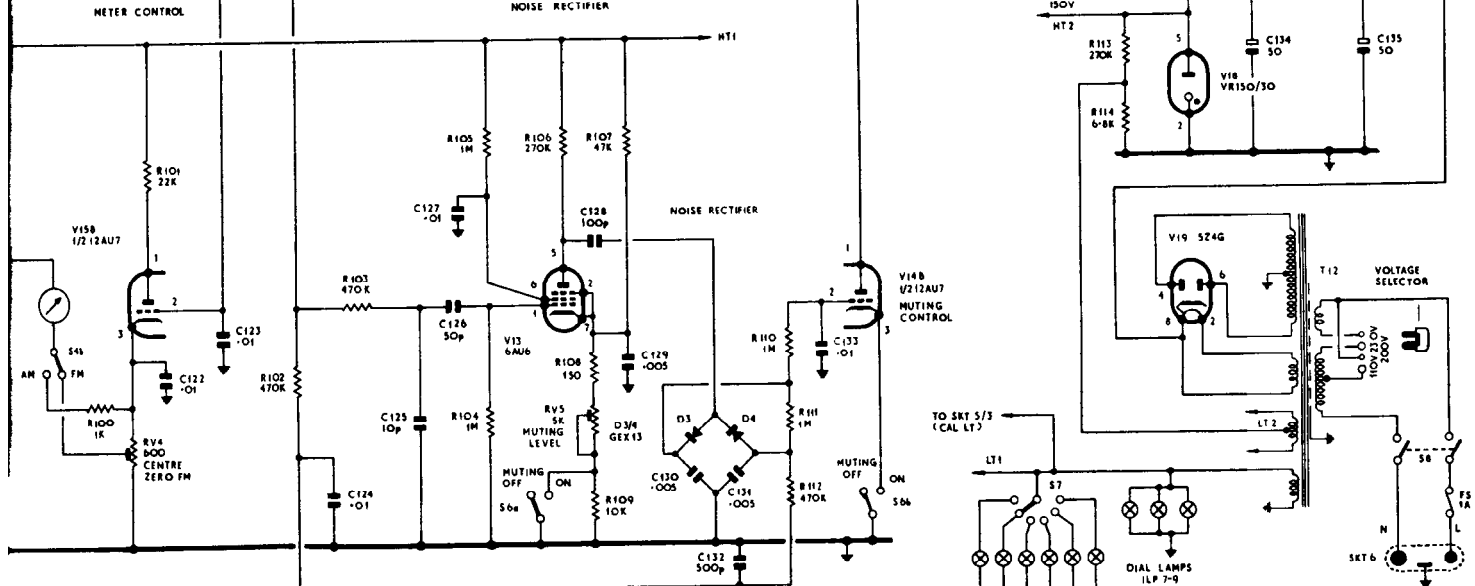

NOTE - S7 IS OPERATED BY THE TURRET SELECTOR MECHANISM

