

EDDYSTONE

COMMUNICATION RECEIVER

Type E.C.R.

For A.C. MAINS, 200/250 VOLTS, 40/60 CYCLES.



BRITISH MADE

**INSTRUCTION MANUAL for
INSTALLATION and OPERATION**

IN ANY COMMUNICATIONS CONCERNING THIS RECEIVER PLEASE QUOTE

SERIAL No. AP.3.

STRATTON & CO. LTD., Bromsgrove Street, Birmingham, ENGLAND

Notes on the ECR-receiver.

Corrections:

- 1: Page 10 line 5 from the bottom: For C76 substitute C30
2. Page 11 line 10 from the top: For C30 substitute C76
3. Page 11 line 12 from the top: For C50 substitute C23
4. Page 11 line 18 from the top: For C76 substitute C30
5. Page 16: Voltage at point N should be 145 Volts.

If your voltmeter is more sensitive than the recommended type you can load the terminals with the following resistors:

Range 250 Volts - 250 kOhms

Range 100 Volts - 100 kOhms

Range 10 Volts - 10 kOhms

ECR with noise limiter.

V6 (6H6) is now used as A.V.C. detector and Noise Suppressor.
V7 is now type 6Q7G, with the diodes connected as signal detectors, the triode being the L.F. amplifier.

Please note the following component changes:

Change R29 = 20 kOhms

" R30 = 250 "

Add R41 = 100 "

" R42 = 100 "

" R43 = 100 "

" R44 = 1 MOhms

" C78 = 0.1 uF Paper

" C79 = 100 pF Ceramic

" C80 = Small trimmer



"Eddystone" Communication Receiver Type E.C.R.



Moving Coil Loudspeaker Cat. No. 1134.

The Eddystone Communication Receiver type "ECR" is the result of extensive research and development, the outcome of which is the production of an instrument highly efficient for all communication purposes.

To obtain the best results the following instructions should be followed with care.

The receiver employs a ten valve superheterodyne circuit and various stages and valve types being shown below:-

<u>Valve Stage</u>	<u>Valve Used</u> <u>International Range</u>	<u>Osram.</u>
H.F. Amplifier (V1)	6K7	W63
Mixer (V2)	6L7	X64
Oscillator (V3)	6J7	Z63
1st I.F. (V4)	6K7	W63
2nd I.F. (V5)	6K7	W63
Signal and A.V.C. Detector (V6)	6H6	D63
^{Noise Supp.} Signal and A.V.C. Detector } ^{DET. &} L.F. Amplifier (V7)	6F5 6Q7	D H63
Output (V8)	6F6	KT63
B.F.O. (V9)	6J7	Z63
Rectifier (V 10)	5Y3	U50

WAVERANGE.

The "ECR" receiver tunes over a frequency range of 32.0 to 1.605 Megacycles. Individual ranges are given below, each range being selected by a hand-operated rotary switch (Fig.1).

	<u>Frequency in Megacycles.</u>		<u>Wavelength in metres.</u>	
Range 1.	32.0	- 14.7.	9.375	- 20.4
Range 2.	15.5	- 7.13	19.7	- 42.2.
Range 3.	7.44	- 3.39	40.04	- 88.5.
Range 4.	3.5	- 1.605	85.8	- 187.

AERIALS.

The aerial input circuit is fitted with two terminals so that either a single wire aerial, a doublet or an impedance line may be used (Fig.3.).

The H.F. amplifier operates on all waveranges . The hexode mixer valve is fed from a separate electron-coupled oscillator which produces little change in frequency with variations of mains voltages or the warming up of the set. The HF, Mixer and Oscillator circuits are tuned by two ganged condensers, one being the bandset (or tank) and the other the bandsread condenser. The controls for these condensers move two indicators over a calibrated scale (Fig.1).

There are two valves in the IF amplifier and three transformers. The first transformer is followed by a crystal filter unit which has phasing and selectivity controls and is also fitted with an "in-out" switch to bring the crystal into circuit when necessary.

The next valve is a double diode. One diode is used for signal detection and the other to provide AVC voltage which is applied to the HF and IF valves. A separate switch is fitted to cut the AVC out and to bring the manual volume control into use.

The LF gain control regulates the amplitude of the signal applied to the next valve which is a triode LF amplifier. The signals are then passed to the output valve which supplies the audio power to the loudspeaker.

A separate valve is used to produce the beat frequency oscillations and this circuit is operated by an "on-off" switch and pitch frequency control.

The rectifier is fed from the mains transformer which can be set for a mains input voltage of 210, 230 or 250 volts.

TELEPHONES.

A Jack is fitted to rear of Chassis and is arranged to accommodate headphones having a resistance of 2,000 ohms.

SPEAKER.

The Eddystone Moving Coil Loudspeaker Cat.No. 1134 is designed for use with this receiver. If any other speaker is used it should be fitted with a transformer that will accommodate the output (7,000 ohms) of the receiver and also have a field resistance of 1000 ohms capable of dissipating 10 watts.

INSTALLATION.

Important. Before switching on the receiver it is necessary to set the mains voltage adjusting screw (as shown in Fig.3), to suit the mains voltage that is being used. The speaker must always be connected, even when headphones only are used, as the loudspeaker field winding is necessary to complete the high tension circuit and provide smoothing.

The positions of the valves are shown in Fig.1.

The "R" meter should be set to zero by means of the adjusting screw shown in Fig.3. The AVC is switched on, The BFO switched off and the aerial disconnected. The screw is then adjusted until the meter reads zero.

OPERATION.

The various names of the controls and their positions are shown in Fig. 1.

ON-OFF switch.

This will switch the set on when turned in a clockwise direction.

L.F.GAIN.

This controls the amount of audio amplification which will be greatest when the knob is turned fully clockwise.

WAVELENGTH SWITCH.

This switch enables the desired waveband to be selected. Ranges 1,2,3 and 4 coils are selected as the knob is turned anti-clockwise and at the same time the calibrated scale is turned so

that the actual waveband in use is always indicated.

MAIN TUNING AND BANDSPREAD CONTROL.

The left hand tuning knob operates the tank condenser and at the same time moves the lower pointer across the calibrated scale. The portion of the dial to be used with reference to this pointer consists of a scale calibrated in Megacycles and a lower one divided into one hundred divisions. Now, while tuning with this control is very easy, critical tuning should be done with the bandspread tuning control on the right. This controls a small bandspread condenser and moves the top pointer along the top scale which is also divided into 100 divisions. It will be noted that the tuning spread of a station is much greater over this scale. The frequency calibrated scale of the tank condenser will only apply if the bandspread condenser is set at its minimum position- that is with the pointer fully to the right.

If it is desired to receive a station of known frequency it is only necessary to move the bandspread condenser to its minimum position and then adjust the main tuning pointer to the required frequency and tune over a degree or so. Most tuning, however, will be by means of the bandspread control, and in this case the main tuning condenser will be set to a slightly higher frequency than the band desired to be covered. Various amateur and broadcast bands are indicated on the lower scale. Thus, supposing it is desired to cover the ten metre amateur band, the main tuning pointer would be set a degree or so above the H.F. end of the band- that is at about 92 divisions. The band would now be extended to nearly full scale length by the bandspread pointer moving over the top scale. When covering the lower frequency bands, say the 80 or 160 amateur band, it will be necessary to re-set the main tuning pointer two or three times, as the bandspread will not cover the full band. This is not a disadvantage as the size of the bandspread condenser is a compromise, and if it covered a large span on the high wavelengths then at the low wavelengths the amount of bandspread would be very small.

Both tuning controls are fitted with a flywheel, which not only enables the pointers to be moved from one end of the dial to the other more quickly, but also facilitates fine tuning.

A.V.C.ON-OFF.

The receiver is fitted with Automatic Volume Control which may be switched off by turning this switch in an anti-clockwise direction. This also switches the H.F.control into operation.

To search for a very weak station the A.V.C. should be off and the H.F. control fully advanced in a clockwise direction. A.V.C. should also be turned off when using the Beat Frequency Oscillator as otherwise the local oscillations will cause the set to become insensitive. For all C.W. reception the A.V.C. should always be switched off.

For Telephony Reception the A.V.C. is switched on so that fading is minimised.

H.F.GAIN.

This controls the amount of H.F. amplification, which is greatest when the knob is turned fully clockwise. It should be remembered that the control is only in use when the A.V.C. is switched off. The H.F. gain control should be retarded on powerful stations to prevent overload of the H.F. and I.F. stages. Actual audio output should always be regulated by the L.F. gain control as the best signal noise ratio can be obtained with the H.F. gain at maximum and the L.F. gain low.

B.F.O. ON-OFF

This switch starts the beat frequency valve oscillating when turned in a clockwise direction and is used when it is desired to receive a C.W. station. The B.F.O. may also be switched on when searching for a weak telephony station although in this case it may be more helpful to watch for deflections in the R meter, which indicates the presence of a carrier wave.

BEAT FREQUENCY CONTROL.

This controls the frequency generated by the local oscillator. The frequency generated is the same as the intermediate frequency of the receiver when the dial is set to 0, and therefore, the audio beat produced will be zero in frequency when the receiver is correctly tuned so that the intermediate frequency produced is 465 Kc/s. Turning the knob clockwise will raise the local oscillator frequency above 465 so that an audio note of rising pitch is produced. Turning the knob anti-clockwise decreases the frequency and an audio note of rising pitch is again produced.

It can be seen that an audio difference frequency will be produced if the B.F.O. is set at 465 Kc/s and the receiver detuned so that the I.F. produced is above or below that value. The receiver should not be operated in this condition as sensitivity and selectivity will be decreased. The tuning control must always be adjusted for maximum output and then zero beat should be produced at the 0 reading in the B.F.O. control. If the crystal

filter is switched in, the zero beat position of the B.F.O. can be found even with no signal, as the characteristic ring note of the crystal will fall to zero in that position. In all circumstances the B.F.O. must be turned from this position to produce the audio beat.

The audio note is usually adjusted to a pitch of about 1000 cycles but this may be varied to suit individual conditions. By adjusting the note of the required signal to a distinctive pitch it may be followed even when other signals are also being received.

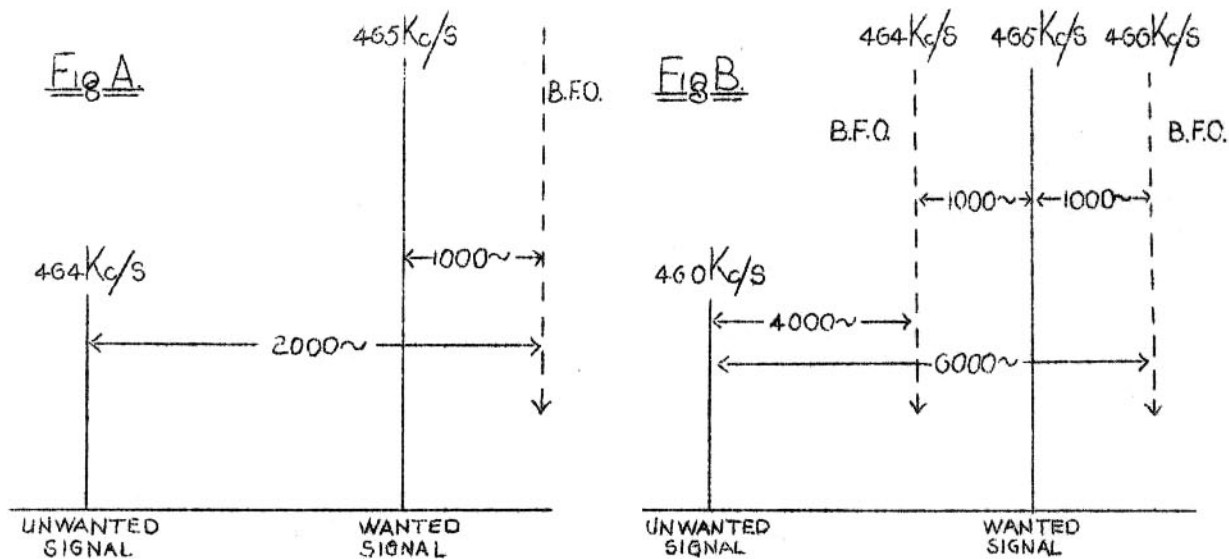

It has already been explained that the B.F.O. may be adjusted to either a higher or lower frequency than the I.F. to produce the beat note, and as the correct choice will reduce interference, reference should now be made to the diagram above.

In Fig. (A) the required signal is shown to produce an I.F. of 465 Kc/s and the unwanted signal a frequency of 464 Kc/s in the I.F. amplifier. Now, we could set the B.F.O. at a frequency of 466 Kc/s, as shown by the dotted lines, which would produce a 1000 cycle note from the wanted signal and a 2000 cycle note from the unwanted signal. By setting the B.F.O. at the other side of the I.F. at exactly 464 Kc/s the unwanted signal will be rejected, as zero beat is produced and the wanted signal will produce a 1000 cycle note as before.

Besides varying the pitch of the wanted signal, that of the interference can also be varied by adjusting the B.F.O. either side

of the I.F. Thus in Fig.b, if the B.F.O. is adjusted to 464 Kc/s, the wanted station will produce a 1000 cycle note and the unwanted station a 4,000 cycle note. If the B.F.O. is adjusted to 466 Kc/s then the pitch of the wanted signal is the same but that of the unwanted signal is 6,000 cycles. If the unwanted signal was producing a still lower frequency in the I.F., or the B.F.O. adjusted to a higher frequency it may be possible to eliminate the interference altogether as the beat note produced would be above audibility. The same considerations apply if the unwanted signal produces a frequency higher than 465 Kc/s.

CRYSTAL ON AND OFF AND CRYSTAL PHASING.

The dial of this control is marked with the word "out" and if this is set to the indicator mark, the crystal filter will be out of circuit, and the I.F. selectivity will have its normal value of about 8 Kc/s wide at 100:1 down.

Turning the phasing control in a clockwise direction will put the crystal in the circuit and the selectivity of the I.F. will be increased to about 150 cycles at 100:1 down. The crystal produces a ringing note which may be varied in pitch by the Beat Frequency Control. The pitch of the ringing note is the same as that which will be produced by the received signal so that the Beat Frequency Control should be adjusted until a ringing note of about 1000 cycles is produced. When the crystal is switched out the selectivity control is switched out of circuit.

At this point it is necessary to explain single signal reception as the receiver is set for this when the crystal is in the circuit.

The superheterodyne receiver produces an intermediate frequency (in this case 465 Kc/s) to pass through the I.F. amplifier, by mixing the incoming signals with the local oscillator, as already explained an audio beat note may be produced for reception of C.W. by adjusting the beat frequency oscillator to a frequency slightly different from the I.F. With the crystal out of circuit it is possible to vary the audio beat, not only by the correct method of adjusting the B.F.O. control, but also by detuning the receiver.

On moving the tuning control the signal circuits are put off tune slightly from the wanted signal but that signal still reaches the mixer at the same frequency. The oscillator frequency has changed, however, so that the I.F. produced has also varied from

465 Kc/s. Because the I.F. response is comparatively wide the frequency will pass through it, but the audio note will change in pitch. The actual I.F. beating with the local oscillator may be varied from a frequency higher to a frequency lower from that of the B.F.O, so that the audio beat produced on tuning through a station, commences at a high frequency drops to zero beat and then rises in frequency again.

Now consider the position when the crystal is in the circuit. We should not vary the tuning as the I.F. amplifier will greatly attenuate an intermediate frequency that differs from 465 Kc/s by more than a few cycles. If we tune the receiver, therefore, the pitch of the note will vary a little but the strength will drop off very quickly. Tuning the receiver for maximum output will result in the correct I.F. being used, this is important.

With the phasing condenser and selectivity control adjustments it will be as well to remember that minimum noise will result when the I.F. is most selective. If the phasing condenser is moved over the 90 divisions this minimum position will be found and this corresponds to what is known as the phasing position. Here the response curve is symmetrical and the selectivity greatest. Unwanted signals, heterodyne notes etc can be rejected by moving the phasing condenser either side of the phasing position. This is possible because one frequency can be almost completely attenuated and this frequency can be varied either side of the I.F. depending on the position of the control. At the same time the overall selectivity will be decreased slightly.

SELECTIVITY CONTROL.

When interference is very bad it will be an advantage to use the crystal filter for telephony reception. The higher audio frequencies will, of course, be attenuated to the high selectivity of the circuits, but under very bad conditions the speech will be more intelligible as noise and interference is reduced. Higher audio frequencies can be passed by making the I.F. less selective by means of the selectivity control. It will be seen, by the resulting set noise, that when the control is turned fully anti-clockwise, selectivity is at a minimum. To increase the selectivity for the reception of C.W. the control should be moved in a clockwise direction.

SEND AND RECEIVE SWITCH.

When using a transmitter this switch should be turned anti-clockwise as then the H.T. circuit is broken and the valves protected.

SIGNAL STRENGTH METER.

9.

This meter is in use when the A.V.C. of the receiver is in operation and enables a report of reception to be given in the well-known amateur units of R strength. To read signal strength the A.V.C. should be switched in and the B.F.O. switched off.

NOISE LIMITER.

This may be brought into operation by moving the switch at the back of the receiver towards the aerial terminals. As the noise limiter produces no losses when in circuit, it may be to advantage to leave the switch in this position.

NOTE: The trimmers of this receiver must not be altered unless it is absolutely necessary to do so, in which case the procedure as given in the alignment instructions must be adhered to.

10.

ALIGNMENT INSTRUCTIONS FOR EDDYSTONE E.C.R. COMMUNICATION
RECEIVER.

Method of indicating Resonance.

If the A.V.C. is switched into operation the R meter will form a very convenient method of indicating resonance. The input signal should be as small as possible and the various trimmers adjusted for maximum reading on the meter.

If some indicator operating from the L.F. output is used the A.V.C. must be switched off. Such an indicator could be an output meter. It would be adjusted for a load of 7,000 ohms, and connected in parallel or in place of the loudspeaker; or an A.C. voltmeter reading 0.5 volts may be connected across the loudspeaker transformer primary in series with a condenser of about 1 mfd.

The I.F. Amplifier.

Before commencing alignment one should make quite certain that the receiver is in the same condition as it will be when operated. For instance, all valves should be tightly in place, **AND** the earth connected, ~~and the chassis in the cabinet.~~

The first procedure is to align the I.F. amplifier.

The signal generator or test oscillator should first be set to give a modulated output of 465 Kc/s and connected between the mixer valve grid and earth. The valve is shown in Fig.1 and the grid is the terminal on the top of the valve. The grid clip connection should first be removed and the high potential lead from the generator connected instead. The earth lead of the generator is connected to the earth connection on the receiver. With the crystal out of circuit and the B.F.O. switched off the following trimmers should be adjusted in the order given, and the local generator being turned down as required.

C40, C38, C37, C36, C34, C76, and C26.

The modulation on the signal generator should now be switched off so that only a pure wave is injected. The phasing knob should be turned just far enough clockwise to switch the crystal in; the selectivity control should be set at 0; and the B.F.O. should be

11.

switched on and adjusted by the beat frequency control, so that the crystal ring produced is about 1000 cycles. The dial of the generator should be rotated until the under output is maximum; the pitch of the note will vary also but to a small extent compared with the signal strength, as has already been explained under the operating instructions. If the R meter is being used as an indicator then the crystal frequency will be indicated by maximum reading. The following trimmers should now be adjusted in this order until no increase in output results.

C40, C38, C37, C36, C34, C30, C26.

The B.F.O. may now be aligned. Switch on the oscillator and set the beat frequency control to zero. Trimmer C50 should now be adjusted until zero beat is produced and the B.F.O. switched off again.

Finally the crystal should be switched out and the modulation of the signal generator switched in. Then with the signal generator dial at the same position as just found, which is the exact crystal frequency, the trimmer C76 should be adjusted.

Selectivity and Phasing controls can be checked when alignment is completed by observing the variation in set noise, as explained in the operating instructions.

General Alignment.

The signal generator should now be connected through a dummy S.W.aerial, or a 400 ohm non-inductive resistance, to the aerial terminal of the receiver. In all cases the input signal should be as small as possible and the receiver operating at maximum sensitivity. The crystal filter should be out of the circuit.

The waverange switch should be turned to the range under consideration and the highest frequency injected. The tuning and bandsread condensers are turned to minimum capacity by moving both pointers to the left of the dial and the signal tuned in by means of the oscillator trimmer.

It will be generally found that the signal can be tuned in with two different positions of the trimmer. In every case the circuit should be left at the highest frequency- that is with the trimmer at its smallest capacity value.

The tracking frequency is next injected and tuned in by the main tuning condenser, after the bandspread condenser has been moved so that the pointer is a few inches from its zero position. The signal is tuned to maximum by adjusting the H.F. and aerial trimmers. Due to the small degree of pulling that may be present at the high wavelengths it may be best to rock the bandspread control to keep the oscillator in tune when the H.F. trimmers are being adjusted. After which it will be necessary to set the range again and the whole process should be repeated until no improvement results. Every range is aligned in the same manner.

	Frequency in Megacycles.				Osc,	Trimmers.	
	H. F.	Tracking.	L.F.			H.F.	Aerial.
Range 1.	32.0	29.0	14.7		C12	C8	C4
" 2.	15.5	14.0	7.13		C13	C9	C5
" 3.	7.44	7.0	3.39		C14	C10	C6
" 4.	3.5	3.11	1.605		C15	C11	C7

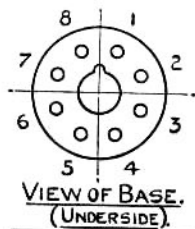

H: Heater.
 A: Anode.
 G: Grid.
 C: Cathode.
 G1: Control grid.
 (For remaining grids count from G1).

VALVE TYPE.	PINS.								TOP CAP.	POSITION IN RECEIVER.
	1	2	3	4	5	6	7	8		
6K7G	-	H	A	G2	G3	-	H	C	G1	V1 V4 V5
6L7G	-	H	A	62864 G3	G3	-	H	C & G5	G1	V2
6J7G	-	H	A	G2	G3	-	H	C	G1	V3 V9
6H6G	-	H	A	G2	A	-	H	C1	-	V6
6F5G	-	H	-	A	-	-	H	C	G	V7
6F6G	-	H	A	G2	G1	-	H	C	-	V8
5Y3G	-	H	-	A	-	A	-	H	-	V10

Valve Pin Connections

EDDYSTONE COMMUNICATION RECEIVER.TYPE ECR.
COMPONENT VALUES.

R1	15,000 ohms	X	R21	500 ohms
R2	100 ohms		R22	50,000 ohms
R3	1,000 ohms		R23	.25 megohms
R4	100 ohms	Meter zero adjuster.	R24	25,000 ohms
R5	10,000 ohms	X	R25	3,000 ohms
R6	1,000 ohms		R26	.1 megohm
R7	1,000 ohms		R27	25,000 ohms
R8	15,000 ohms		R28	3,000 ohms
R9	25,000 ohms	X	R29	50,000 ohms
R10	1,000 ohms		R30	.5 megohms
R11	25,000 ohms	X	R31	.5 megohms A.F.gain
R12	1,000 ohms		R32	.25 megohms
R13	.1 megohm		R33	.5 megohms
R14	.25 megohms		R34	2,200 ohms
R15	70,000 ohms		R35	.25 megohms
R16	20,000 ohms	X	R36	20,000 ohms
R17	1 megohm		R37	400 ohms X
R18	300 ohms		R38	.1 megohm
R19	.1 megohm		R39	50,000 ohms R.F.gain.
R20	50,000 ohms		R40	50,000 ohms.

X 2,1 watt resistances in parallel to give specified value.

EDDYSTONE COMMUNICATION RECEIVER.TYPE ECR.
COMPONENT VALUES.

C1 and C1A 21-239 mmfd with C1A at minimum)
 C2 and C2A 21-239 mmfd with C2A at minimum) C1, C2 & C3 (Air)
 C3 and C3A 21-239 mmfd with C3A at minimum) are ganged.

C1A 10 mmfd max. bandsread)
 C2A 10 mmfd max. bandsread) Ganged. Air.
 C3A 10 mmfd max. bandsread)

C4 3-30 mmfd Air	C36 Incorporated in I.F.Units.Air
C5 3-30 mmfd Air	C37 do do do
C6 3-30 mmfd Air	C38 do do do
C7 3-30 mmfd Air	C39 .1 mfd Paper
C8 3-30 mmfd Air	C40 Inc.in I.F. Units. Air.
C9 3-30 mmfd Air	C41 100 mmfd Ceramic
C10.3-30 mmfd Air	C42 100 mmfd Ceramic
C11.3-30 mmfd Air	C43 100 mmfd Ceramic
C12.3-30 mmfd Air	C44 100 mmfd Ceramic
C13.3-30 mmfd Air	C45 100 mmfd Ceramic
C14.3-30 mmfd Air	C46 100 mmfd Ceramic
C15.3-30 mmfd Air	C47 .01 mfd Mica
C16. .006 mfd Mica	C48 3 mmfd Ceramic
C17 .005 mfd Mica	C49 100 mmfd Ceramic
C18 .0017 mfd Mica	C50 .01 mfd Mica
C19 960 mmfd Mica	C51 .005 mfd Mica
C20 10 mmfd Ceramic	C52 .1 mfd Paper
C21 10 mmfd Ceramic	C53 .1 mfd Paper
C22 .1 mfd Paper	C54 .1 mfd Paper
C23 3-30 mmfd Air	C55 .1 mfd Paper
C24 .0001 mfd Ceramic	C56 .1 mfd Paper
C25 2-15 mmfd Air	C57 .1 mfd Paper
C26 3-30 mmfd Air	C58 100 mmfd Ceramic
C27 75 mmfd Ceramic	C59 .1 mfd Paper
C28 65 mmfd(XTL Selectivity)	C60 .02 mfd Paper
C29 20 mmfd Ceramic Air)	C61 .1 mfd Paper
C30 3-30 mmfd Air	C62 .1 mfd Paper
C31 75 mmfd Ceramic	C63 .1 mfd Paper
C32 1-18 mmfd XTL Phasing. Air.	C64 .1 mfd Paper
C33 20 mmfd Ceramic	C65 .1 mfd Paper
C34 3-30 mmfd Air	C66 .1 mfd Paper
C35 .0001 mfd Ceramic	C67 .1 mfd Paper

- | | | | | | |
|------|-------------|------------------|------|-----------|--------------|
| C68) | 20 + 20 mfd | 30V Electrolytic | C73 | .1 mfd | Paper |
| C69) | | | C74) | 8 + 8 mfd | Electrolytic |
| C70 | 4 mfd | Paper | C75) | | |
| C71 | 8 mfd | Electrolytic | C76 | 3-30 mmfd | Air |
| C72 | .1 mfd | Paper | C77 | .1 mfd | Paper |

V1	6K7G	H.F.Amp.	Mullard
V2	6L7G	Mixer	"
V3	6J7G	Osc.	"
V4	6K7G	1st.I.F.	"
V5	6K7G	2nd.I.F.	"
V6	6H6G	Noise Supp. & 2nd. Det. A.V.C. }	"
V7	6F5G 6Q7G.	DET. & 1st. L.F. }	"
V8	6F6G	Output	"
V9	6J7G	B.F.O.	"
V10	5Y3G	Rectifier.	"

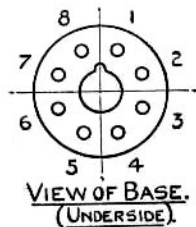

H: Heater.
A: Anode.
G: Grid.
C: Cathode.
G1: Control grid.
(For remaining grids count from G1).

VALVE TYPE.	PINS.								POSITION IN RECEIVER.	
	1	2	3	4	5	6	7	8 TOP CAP.		
6K7G	-	H	A	G2	G3	-	H	C	G1	V1 V4 V5
6L7G	-	H	A	G2	G3	-	H	C & G5	G1	V2
6J7G	-	H	A	G2	G3	-	H	C	G1	V3 V9
6H6G	-	H	A	G2	A	-	H	C1	-	V6
6F5G	-	H	-	A	-	-	H	C	G	V7
6F6G	-	H	A	G2	G1	-	H	C	-	V8
5Y3G	-	H	-	A	-	A	-	H	-	V10

Valve Pin Connections

SPEC. 160 - VOLTAGES. (APPROXIMATE).

Receiver tuned to 7 Mc. with A.V.C. ON, Xtl. out, B.F.O. OFF
and no aerial. Voltmeter used:- 0-250V. 1000 ohms/volt.
(Except where otherwise stated).

ALL VOLTAGES MEASURED FROM CHASSIS.

A	110	L	220
B	215	M	6.4 (Voltmeter range 0-10V).
C	2.6 (Voltmeter range 0-10V).	N	45
D	130	O	0.8 (Voltmeter range 0-10V).
E	220	P	210
F	5.8 (Voltmeter range 0-10V).	Q	225
G	Ranges 2,3 & 4 :- 125 V	R	16 (Voltmeter range 0-100V).
H	Range 1:- 205 V.	S	85 Volts negative "
I	105	T	0-25V. A.V.C. OFF "
J	220	U	40. B.F.O. ON "
K	6.4 (Voltmeter range 0-10V).	V	105 Volts negative.
	100		

SPEC. 160

INDUCTANCE VALUES.COIL UNIT.

	RANGE	PRIM	SEC.	COLOUR CODE
AERIAL	1		.4 Micro H.	1 Blue Spot
	2		1.83 "	1 Yellow "
	3		8.3 "	1 Red "
	4		38.18 "	1 Green "
H.F.	1		.4 Micro H.	2 Blue Spots
	2		1.87 "	2 Yellow "
	3		8.25 "	2 Red "
	4		38.18 "	2 Green "
OSC.	1	.3 Micro H.		3 Blue Spots
	2	1.67 "		3 Yellow "
	3	7.15 "		3 Red "
	4	27.88 "		3 Green "

CRYSTAL INPUT TRANS:-, PRIM. 1.1 mH SEC. 1.2 mH.

" OUTPUT " .950 mH.

B.F.O. COIL:- .850 mH.

L.S.FIELD:- 10.5 H.

L.F.CHOKE:- 10.5 H.

SPEC. 160.APPROXIMATE RESISTANCE VALUES (IN OHMS).COIL UNIT.

	<u>RANGE.</u>	<u>PRIM.</u>	<u>SEC.</u>
AERIAL	1	.72	.01
	2	.04	.025
	3	.1	.26
	4	.26	.9
H.F.	1	.51	.02
	2	.04	.03
	3	.07	.26
	4	.32	.8
OSC.	1		.01
	2		.025
	3		.25
	4		1.9

CRYSTAL INPUT TRANS:-	PRIM. 9.55	SEC. 9.3.
" OUTPUT " :-	6.75	
B.F.O. COIL :-	8.4	
L.S. FIELD:-	1,000 (D.C.)	
L.F. CHOKE:-	230 (D.C.)	

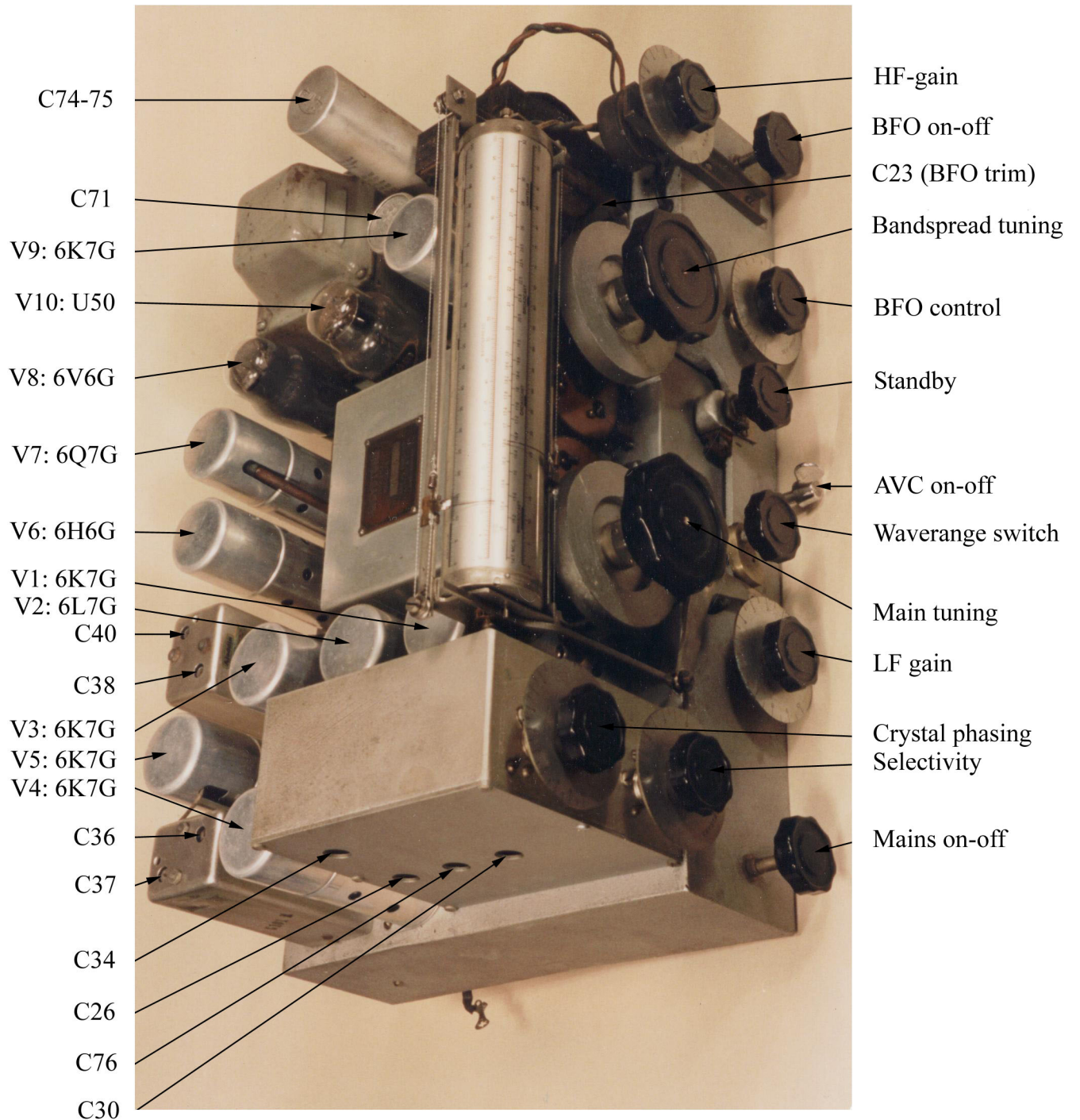

Chassis Layout showing Valve and Trimmer Positions

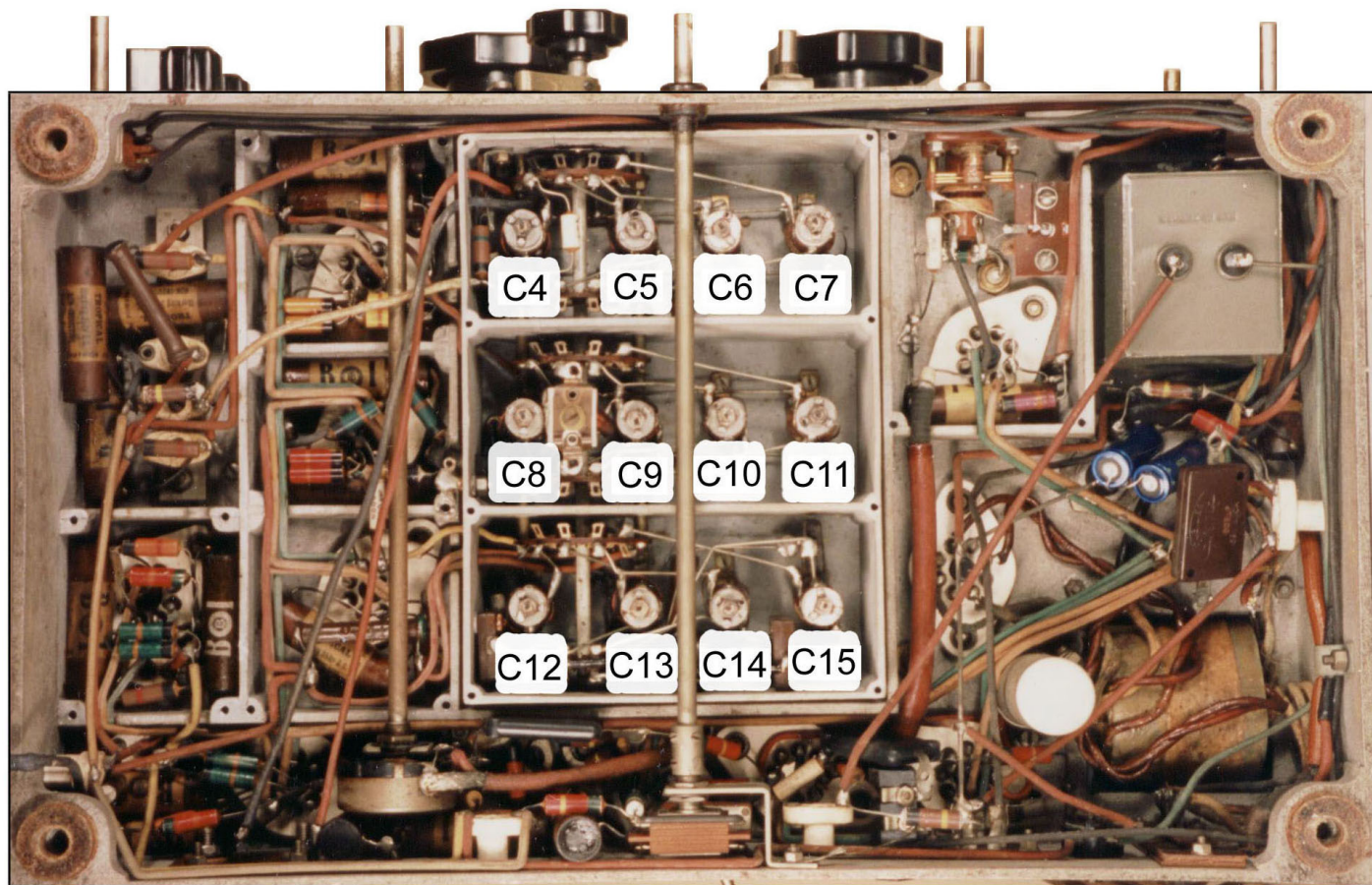

Frequency in Megacycles.

Trimmers.

	H.F.	Tracking.	L.F.	Osc.	H.F.	Aerial.
Range 1.	32.0	29.0	14.7	C12	C8	C4
" 2.	15.5	14.0	7.13	C13	C9	C5
" 3.	7.44	7.0	3.39	C14	C10	C6
" 4.	3.5	3.11	1.605	C15	C11	C7

REAR CONNECTIONS

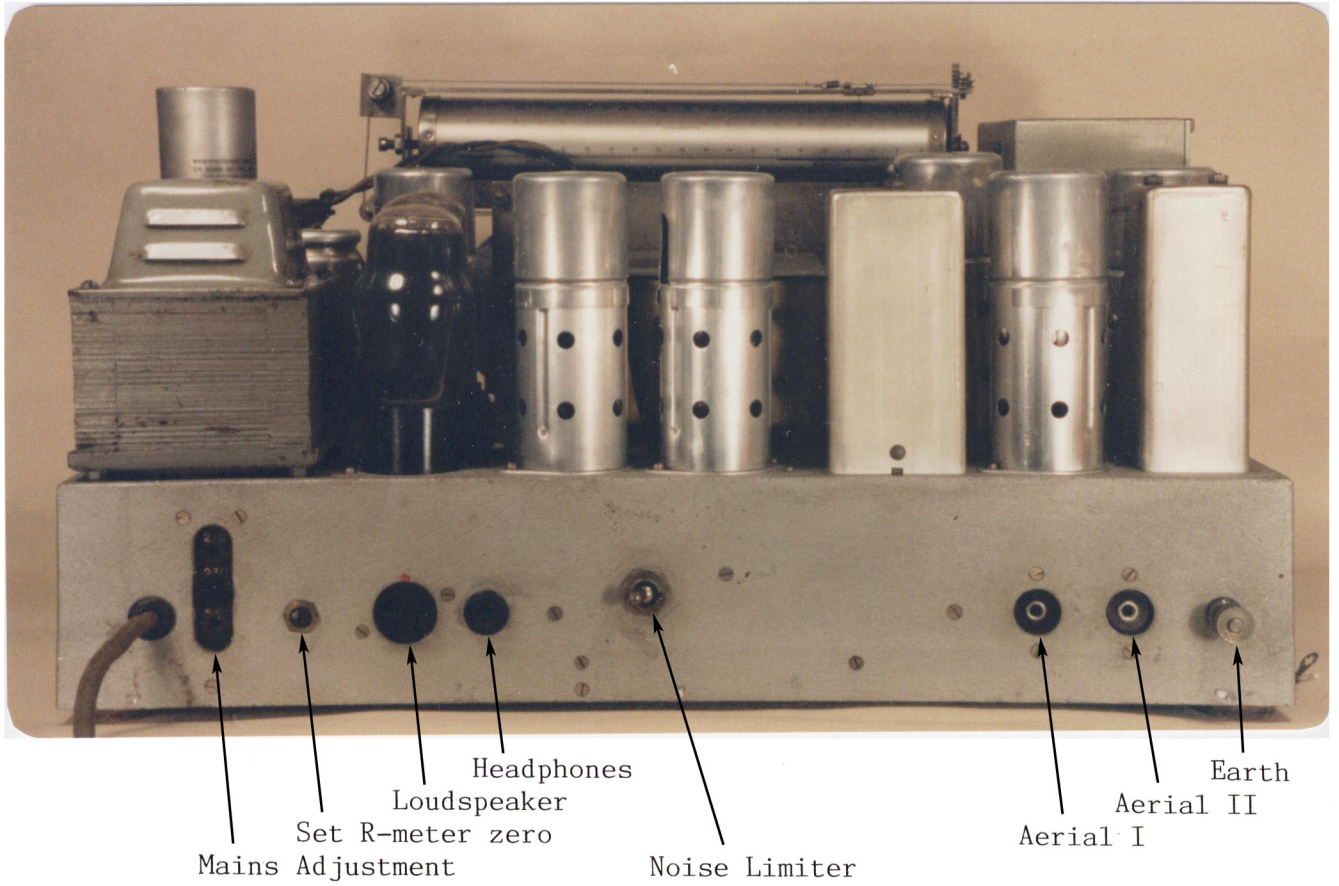

DRUMS and PULLEYS

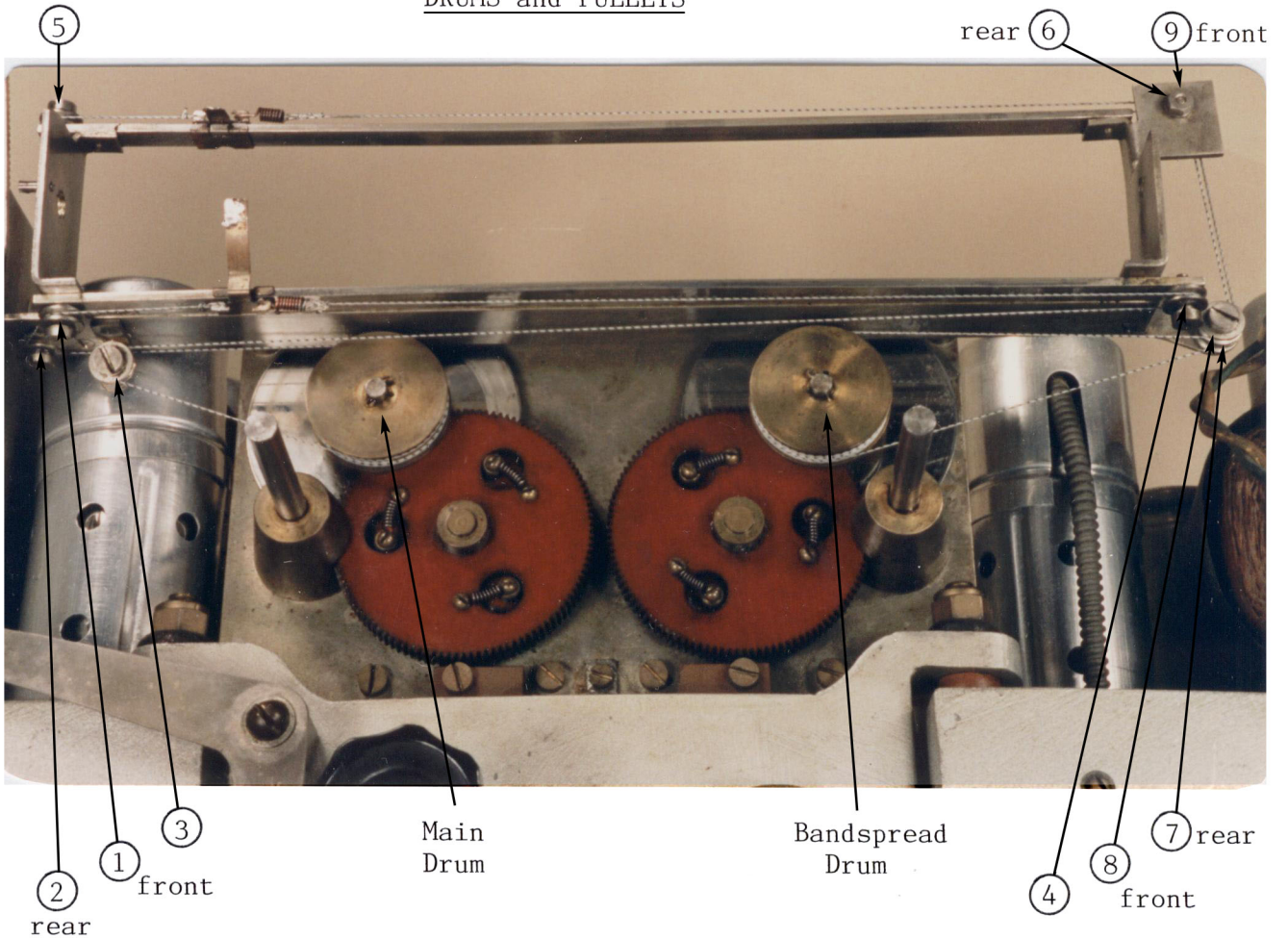

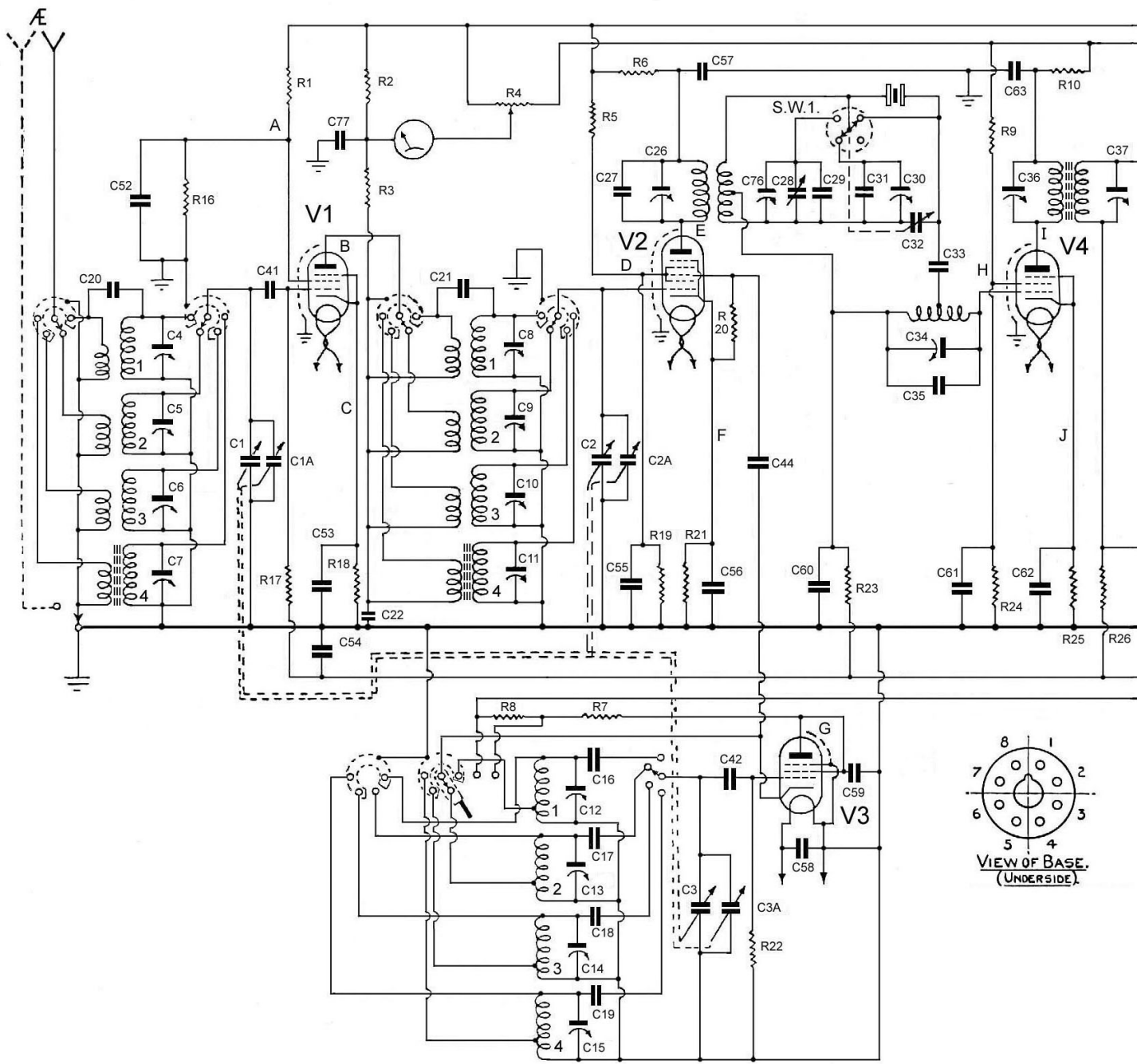

Blueprint 387, RF-section

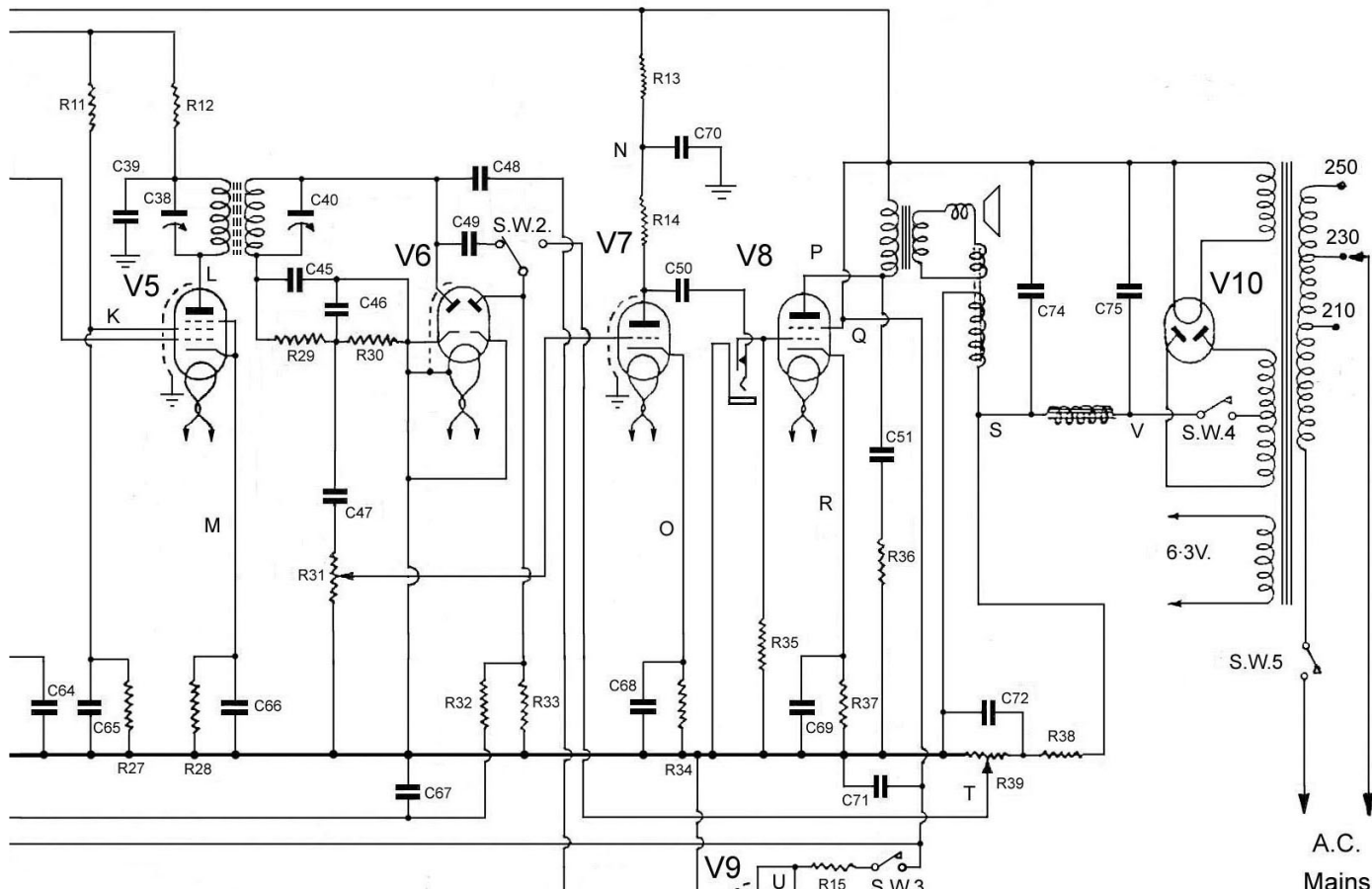

A.C. Mains

H: Heater.
 A: Anode.
 G: Grid.
 C: Cathode.
 G1: Control grid.
 (For remaining grids count from G1).

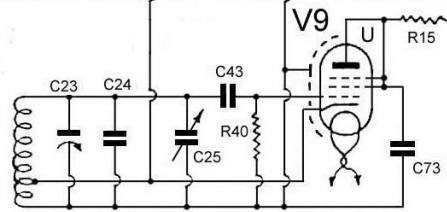

Valve Type	Pins								Position in Receiver	
	1	2	3	4	5	6	7	8		top cap
6K7G	—	H	A	G2	G3	—	H	C	G1	V1, V4, V5
6L7G	—	H	A	G2,4	G3	—	H	C, G5	G1	V2
6J7G	—	H	A	G2	G3	—	H	C	G1	V3, V9
6H6G	—	H	A2	C2	A1	—	H	C1	—	V6
6F5G	—	H	—	A	—	—	H	C	G	V7
6F6G	—	H	A	G2	G1	—	H	C	—	V8
5Y3G	—	H	—	A	—	A	—	H	—	V10

Valve Pin Connections

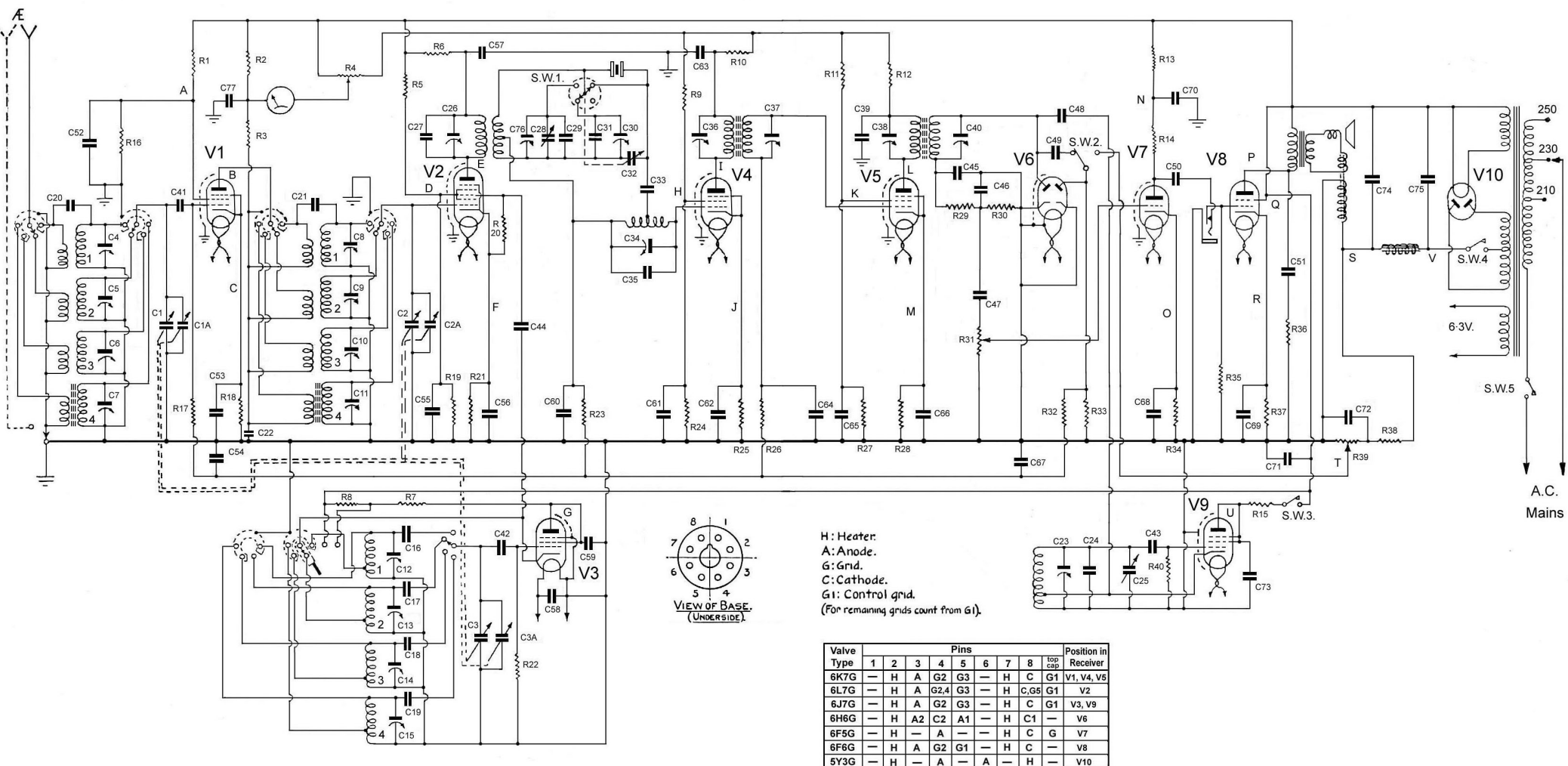

H: Heater.
 A: Anode.
 G: Grid.
 C: Cathode.
 G1: Control grid.
 (For remaining grids count from G1).

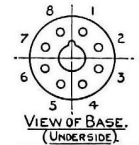

Valve Type	Pins								Position in Receiver	
	1	2	3	4	5	6	7	8		
6K7G	-	H	A	G2	G3	-	H	C	G1	V1, V4, V5
6L7G	-	H	A	G2,4	G3	-	H	C, G5	G1	V2
6J7G	-	H	A	G2	G3	-	H	C	G1	V3, V9
6H6G	-	H	A2	C2	A1	-	H	C1	-	V6
6F5G	-	H	-	A	-	-	H	C	G	V7
6F6G	-	H	A	G2	G1	-	H	C	-	V8
5Y3G	-	H	-	A	-	A	-	H	-	V10

Valve Pin Connections

Blueprint 387, RF-section

Blueprint 387, AF-section

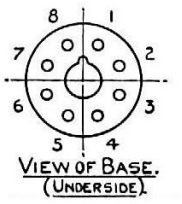
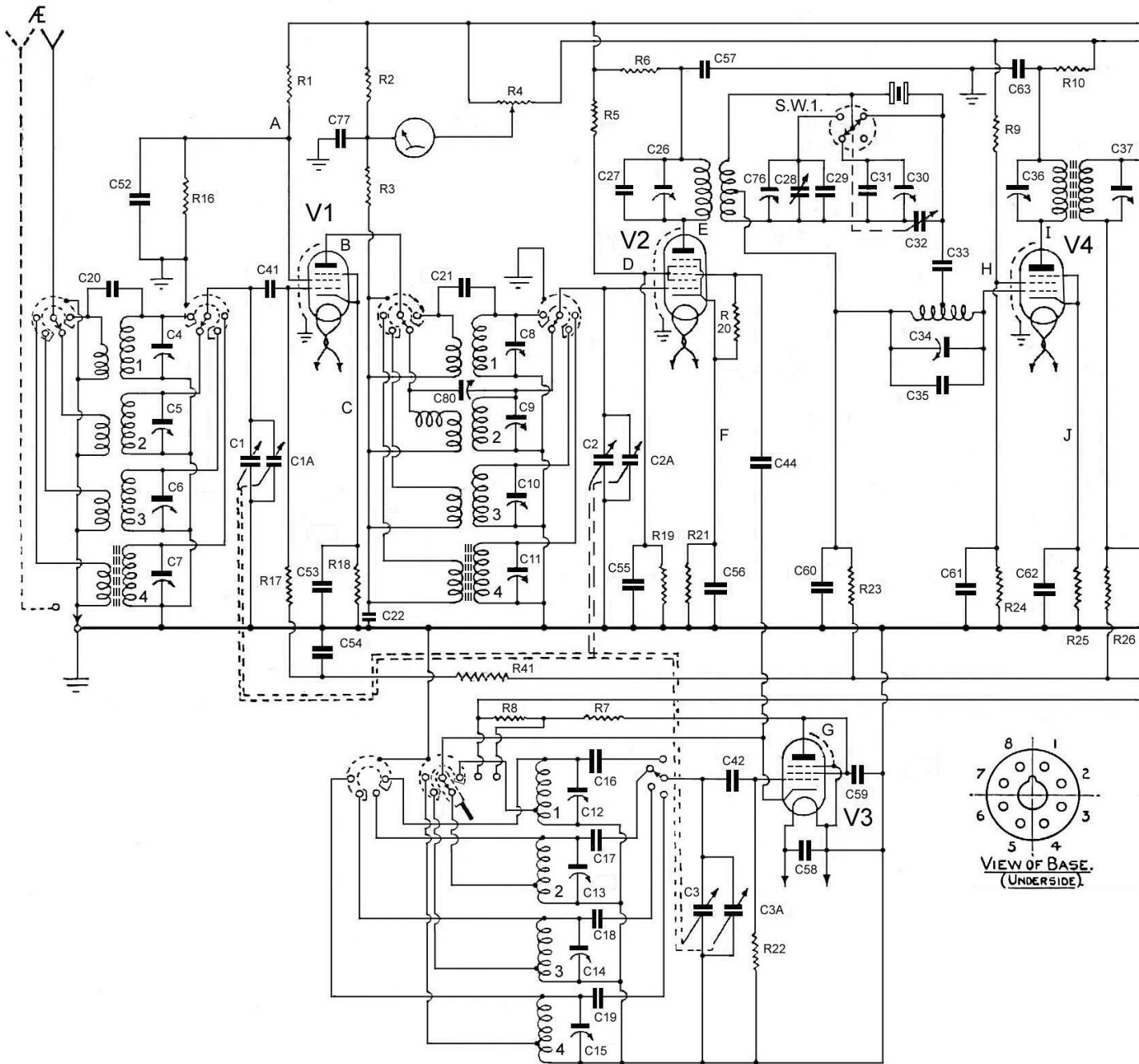

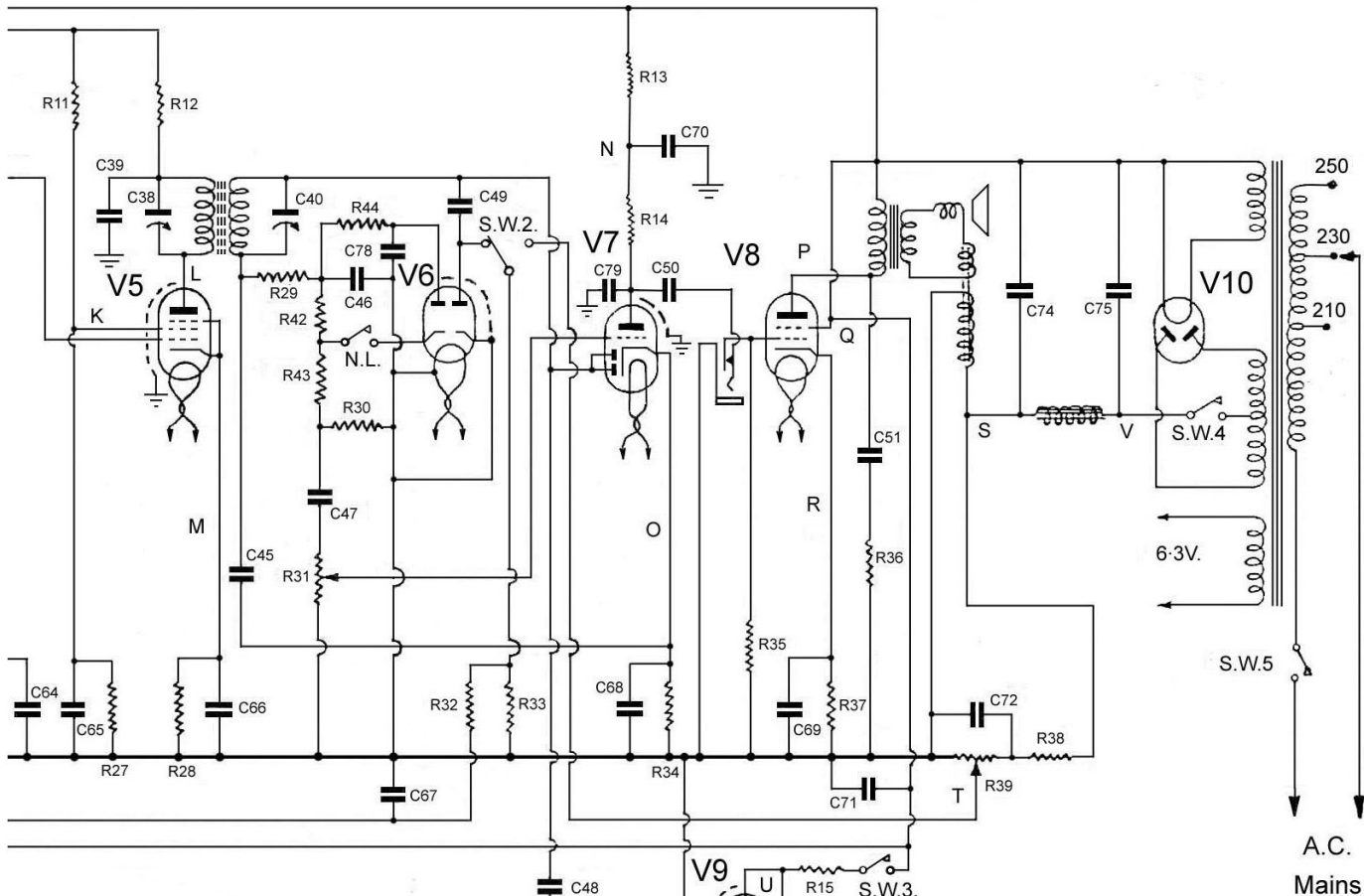

H: Heater.
 A: Anode.
 G: Grid.
 C: Cathode.
 G1: Control grid.
 (For remaining grids count from G1).

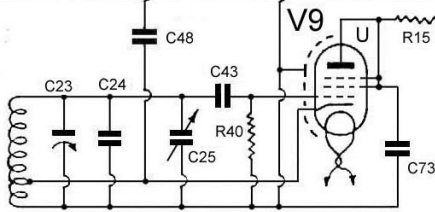

Valve Type	Pins								Position in Receiver	
	1	2	3	4	5	6	7	8		
6K7G	—	H	A	G2	G3	—	H	C	G1	V1, V4, V5
6L7G	—	H	A	G2,4	G3	—	H	C, G5	G1	V2
6J7G	—	H	A	G2	G3	—	H	C	G1	V3, V9
6H6G	—	H	A2	C2	A1	—	H	C1	—	V6
6Q7G	—	H	At	Ad1	Ad2	—	H	C	G	V7
6F6G	—	H	A	G2	G1	—	H	C	—	V8
5Y3G	—	H	—	A	—	A	—	H	—	V10

Valve Pin Connections

EDDYSTONE COMMUNICATION RECEIVER TYPE E.C.R.

(With noise limiter.)

Diagram reconstructed in March 1998 from a single receiver.
 For component values please consult 'Notes on....'

T.M.

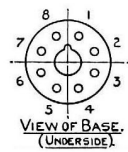
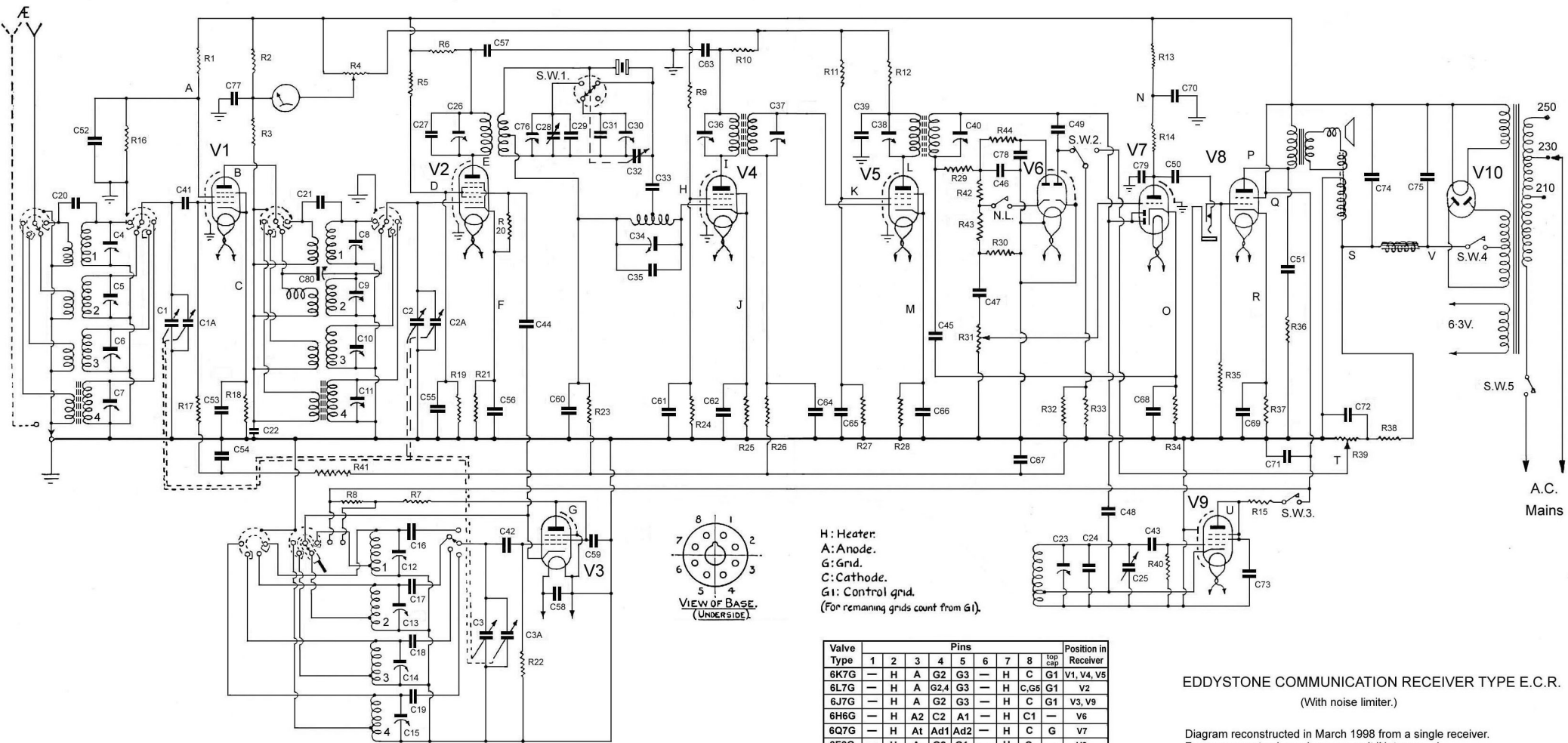

H: Heater.
 A: Anode.
 G: Grid.
 C: Cathode.
 G1: Control grid.
 (For remaining grids count from G1).

Valve Type	Pins								Position in Receiver	
	1	2	3	4	5	6	7	8		
6K7G	-	H	A	G2	G3	-	H	C	G1	V1, V4, V5
6L7G	-	H	A	G2,4	G3	-	H	C, G5	G1	V2
6J7G	-	H	A	G2	G3	-	H	C	G1	V3, V9
6H6G	-	H	A2	C2	A1	-	H	C1	-	V6
6Q7G	-	H	At	Ad1	Ad2	-	H	C	G	V7
6F6G	-	H	A	G2	G1	-	H	C	-	V8
5Y3G	-	H	-	A	-	A	-	H	-	V10

Valve Pin Connections

EDDYSTONE COMMUNICATION RECEIVER TYPE E.C.R.
 (With noise limiter.)

Diagram reconstructed in March 1998 from a single receiver.
 For component values please consult 'Notes on...'

T.M.

Restranging an Eddystone ECR receiver.

Remove the case and put the two tuning knobs back on, turn the variable capacitors to maximum capacitance, that is all the way counter clockwise. Now remove the knobs and the two flywheels, noting that they are of different size.

Each dial drive consists of a drum and a number of pulleys. The two drums are connected to the tuning drive via split gears, so there is no backlash. Examining the drums you will find a hole drilled almost diametrically through, on a sample receiver the holes were at three o'clock and nine o'clock for both drums.

Check that all pulleys run smoothly with no perceptible friction, and that the two gliders carrying the pointers slide smoothly on their respective rails. I recommend that you unsolder the pointers, as it is very easy to bend them inadvertently.

Now place the receiver in front of you as if you were to operate it. I've numbered the pulleys as follows:

1. This is the front horizontal pulley on the left side below the dial
2. " " rear " " " " "
3. This is the vertical pulley to the left of the main tuning drum.
4. This is the horizontal pulley on the right side below the dial.
5. This is the horizontal pulley on the left side above the dial.
6. This is the rear vertical pulley on the right side above the dial
7. " " " " " below "
8. " front " " " " "
9. " " " " " above "

Numbers 1, 2, 3 and 4 belong to the main tuning, numbers 5, 6, 7, 8 and 9 belong to the bandsread tuning. The cords pass over the pulleys in succession as indicated by their numbers.

Examine the position of pulleys 7 and 8 with respect to the bandsread drum as the cord from these pulleys must arrive at the drum at 90 degrees to the axis of the drum, otherwise the cord may unwind off the drum while tuning. If necessary fit washers between the pulleys and the frame they are mounted on.

The original cord was a very thin steel wire, if you are unable to find this a non-stretch monofilament fishing-line about 0.1-0.2 mm thickness will do. For easy threading you need about 1.5 metres per drive. The following description is for restranging with the fishing-line.

Main dial drive.

Take the cord and make a loop just large enough to pass over the notch in the glider, note that you may have to take it off again while adjusting the tension. Push the bottom glider all the way to the left, hook the loop on to the lefthand notch of the glider. From now on you must keep the cord under tension. Put the cord on to pulley no. 1 from the front and round on the left side, further to pulley no. 2 coming out at the rear pointing right. Lead the cord behind pulley no. 3 directly to the top of the main tuning drum. Now put 3 and 1/3 turns of cord on to the drum in a clockwise direction and outwards, making sure not to make turns cross. Wind on further to reach the nearest hole in the drum. All the cord must be on the innermost half of the drum so you can thread the cord through the hole.

Now thread the cord through the hole and put on 1 full turn and whatever it takes to exit the drum at 7 o'clock, still clockwise and outwards, round pulley no. 3 clockwise and out to the right, passing in front of the main drum in the direction of pulley no. 4, round this from the rear to the front and to the right side of the glider. Now this is where you attach the small spring. In tightening the cord you will probably find that the glider is no longer all the way to the left, you can correct this by making single knots on the cord as close to the first loop as possible. This is not difficult if you use the tuning control to put the glider in the mid-position. Ideally you should end up with a cord drive with just enough tension to take up the slack at all positions along the rail, and with about the same distance from the end stop at the extreme positions.

Bandsread drive.

Start with a loop as above, glider all the way to the left, slide the loop on to the left notch on the glider, pass the cord round the pulley no. 5 from the front to the back. Keep tension on the cord from now on. Feed cord to the right, round pulley no. 6 (the rear one), down round pulley no. 7 and to the bandsread drum, touching it a 5 o'clock. Now put 3 and 1/3 turns of cord on to the drum in a clockwise direction and outwards, making sure not to make turns cross. Wind on further to reach the nearest hole in the drum. All the cord must be on the innermost half of the drum so you can thread the cord through the hole. Now thread the cord through the hole and put on 1 full turn and whatever it takes to exit the drum at the top, still clockwise and outwards, pointing right. Feed cord round pulley no. 8 and upwards, round pulley no. 9, to the left and to the glider where it is attached to the spring here. The adjustment of position and tension is as for the main drive.

You will now see that at the extreme ends of tuning there is at least one full turn of cord on the respective half of the drums, in order to guide the cords correctly while winding on. You may have to move this single turn towards the centre of the drums to get enough space for the rest of the cord.

Now put the flywheels back on, fit the tuning knobs and try out the drives. If you are satisfied you can solder the pointers back on, making sure that the main pointer is set to the lowest frequency when the main tuning knob is turned all the way counter-clockwise and the bandsread pointer points to 100 (to the right) when the bandsread tuning knob is turned all the way clockwise.