

other quality electronic products
engineered by Genave for general
use at moderate prices

Aviation:

Alpha/600
All transistor Nav/Com
Beta/5000
TSO'd ATC Transponder
Sigma/1500
Digital ADF
Delta/303
Marker Beacon Receiver

Marine:

Marine/Master-25w
25 watt Marine R/T
Marine/Gain-50
3 db gain Marine antenna
Marine/Gain-100
6 db gain Marine antenna
Marine/Gain-50M
3 db gain Sailboat antenna

Amateur:

GTX-10
2-Meter FM
10 watt output, rotary channel selector
GTX-2
2-Meter FM
30 watt output, pushbutton channel selection

MANUFACTURED IN THE UNITED STATES

marine division



GENERAL AVIATION ELECTRONICS, INC.

4141 Kingman Drive
Indianapolis, Indiana 46226
AREA (317) 546-1111

Specifications subject to change without notice.

© Copyright, 1973, General Aviation Electronics, Inc. All Rights Reserved.
Printed in U.S.A. 1973

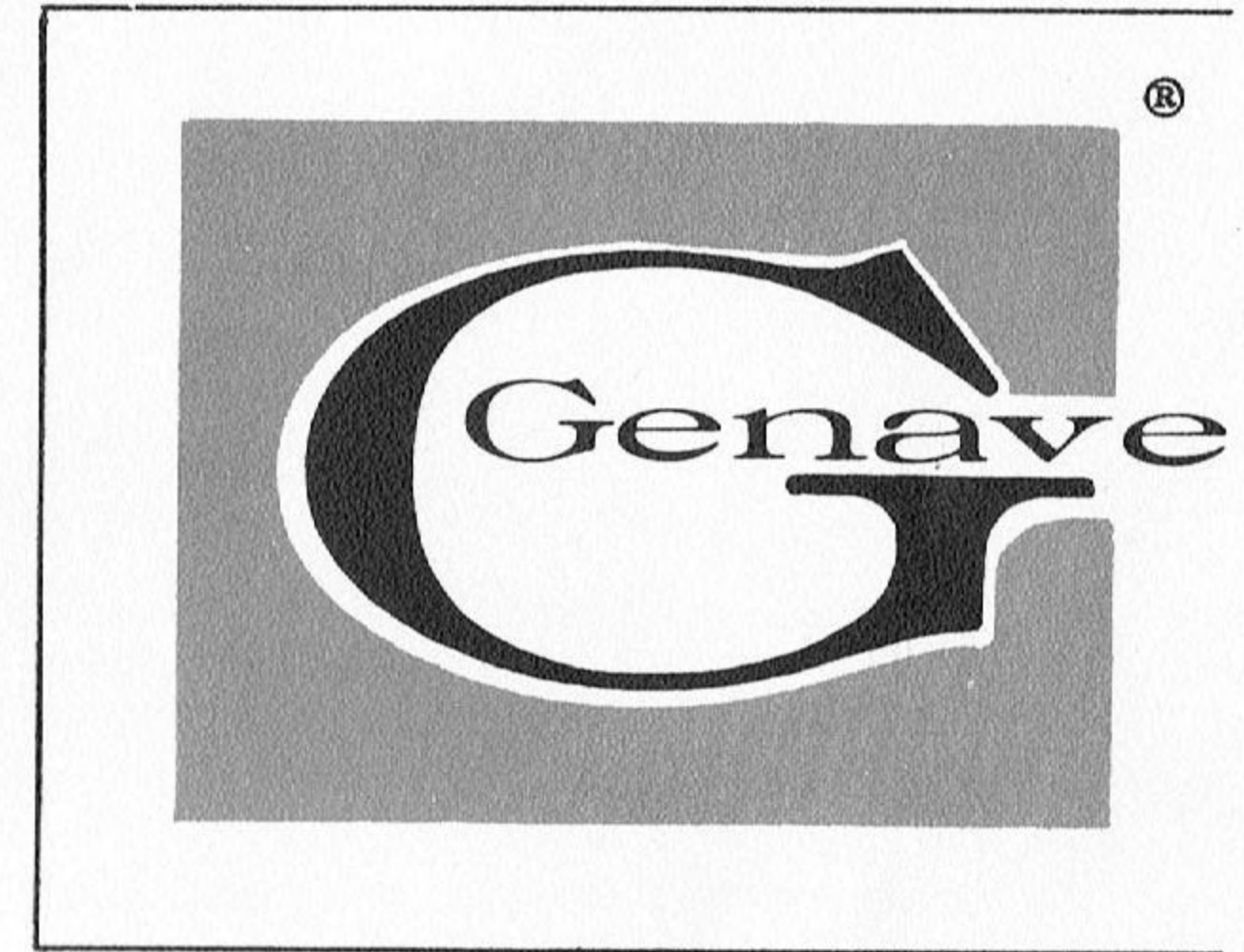

OWNERS MANUAL

CONGRATULATIONS!

You now own one of the finest pieces of electronics equipment available for amateur radio use. The GTX-200 is the end product of research, design and engineering by General Aviation Electronics, Inc. (Genave)—space age innovators in electronic equipment for general aviation, marine and the communications industries.

GTX-200 2 Meter
FM Transceiver

Price \$2.00

Warranty

General Aviation Electronics, Inc., warrants this product to be free from material defects for a period of 90 days from the date of purchase.

Our obligation under this warranty is to replace any parts (except service items such as bulbs, fuses, etc.) which upon our examination appear to us to be defective in materials or workmanship, with any labor charges involved at the cost of the owner, provided the unit is delivered to the Factory within the specified time period.

The owner may elect to have the unit repaired at an authorized Genave dealer, in which case Genave will replace only those defective parts returned shipping pre-paid to the Factory, and will not be responsible in any way for payment of any labor or other charges incurred therein.

This warranty does not apply to defects, malfunction, or breakage due to improper installation or to the servicing thereof by other than an authorized Genave dealer, or due to abuse, misuse, tampering, submersion in water or willful destruction of the unit.

The Company offers no other guarantees or warranties expressed or implied.

Your unit was under strict quality control during its fabrication and was thoroughly checked by skilled technicians prior to shipment. With reasonable care and handling it will provide years of satisfactory operation.



Specifications:

GENERAL:

Front Panel Size: 6 1/2" x 2 1/2"
Over-all Dimensions: 9" deep x 6 1/2" wide x 2 1/2" high
Number of Transistors: 11 all silicon transistors, 6 diodes, 2 zeners, 6 FETs, 3 integrated circuits
Power Supply: 12 VDC system, negative ground
Current Drain: Receive: .09 amps
Transmit: Hi 5.0 amps
Lo 1.7 amps
Frequency Range: 144 to 148 MHz
Number of Channels: 10 Xmit x 10 Receive = 100 poss. channel combinations. (Includes 146.94 MHz. Remaining frequencies at nominal charge each for installation at factory or by owner).
Weight: 5 lbs. (approx.)

RECEIVE:

Sensitivity: .25 microvolts nom. for 12 db

SINAD

.35 microvolts nom. for 20 db quieting
Image: More than 45 db
Spurious: More than 50 db
Selectivity: ±8 kHz, 3 db or less
Adjacent Channel Rejection: ±30 kHz, more than 65 db
Receiver Circuit: Double conversion, superheterodyne, crystal controlled
Audio Output: 1.5 watts at less than 15% distortion
Modulation Acceptance: More than 7.5 kHz
Squelch Threshold: .35 microvolts max.

TRANSMIT:

Frequency Range: 144 to 148 MHz
Power Output: 30 watts, nom.; 25 watts min. @ 14 VDC input
Output Impedance: Matches standard 50 ohm amateur antennas
Deviation: Adjustable to 10 kHz max.

The GTX-200 was designed for fixed, mobile, and portable operation.

The GTX-200 features paired or independent frequency selection at the flip of a single mode selector switch. In the "unlocked" mode the operator can independently select the transmit and receive frequencies desired. The "locked" mode allows the operator to transmit and receive on a preselected frequency pair.

INSTALLATION

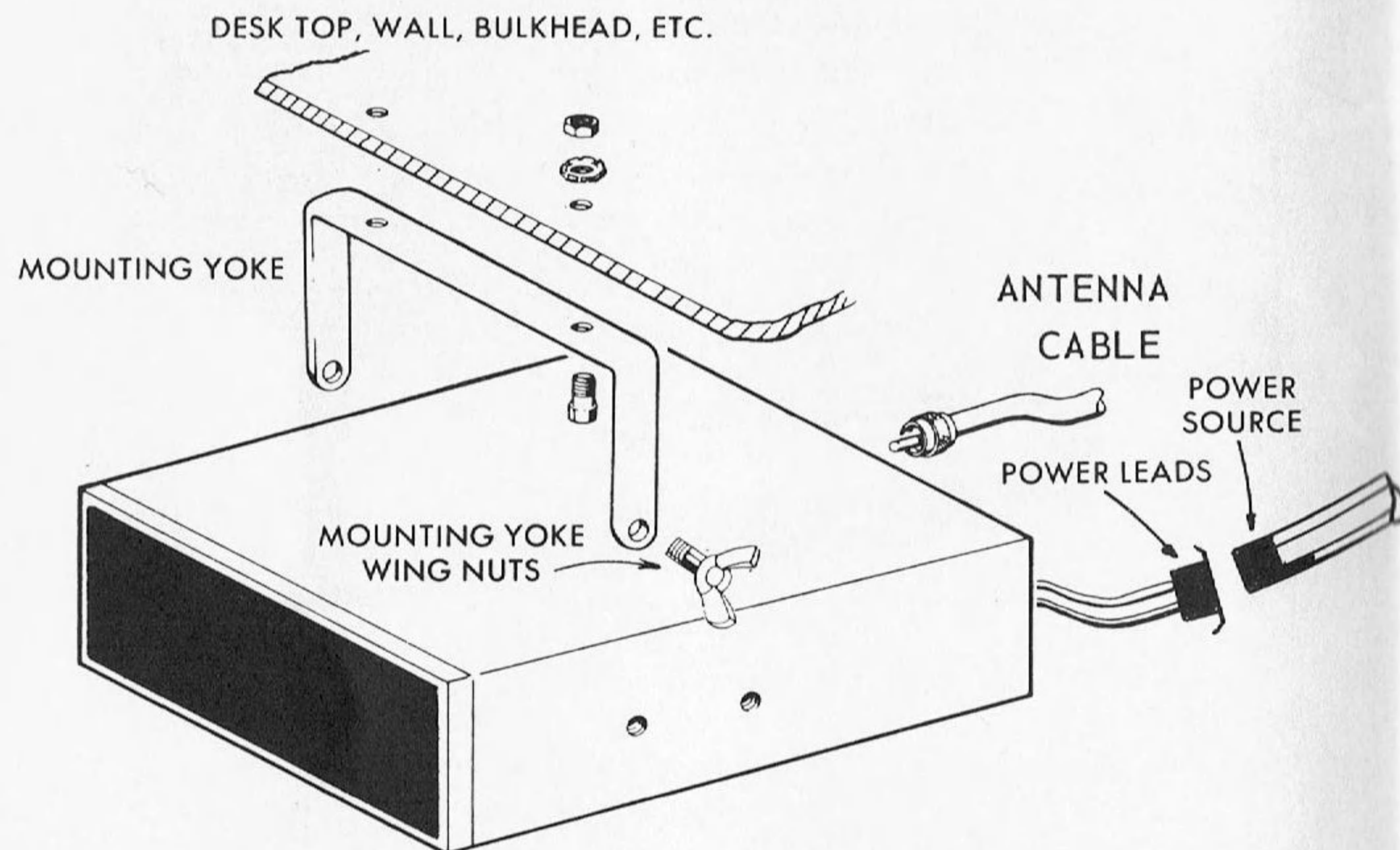

FIXED OPERATION

1. Remove the mounting yoke from the top of unit and reposition the mounting yoke on the bottom side of the unit to function as a supporting stand.
2. Connect the color coded power leads to the power source. The power source can consist of a battery or a well regulated power supply (1.5 V max. peak ripple) such as the power supply shown in figure 3. The unit will only operate on a supply with negative ground. If it is necessary to extend the power leads, use #14 gauge or heavier insulated copper wire. If polarity is reversed the unit will be inoperative. If this occurs check wiring polarity (RED to positive and BLACK to negative) and the protective fuse. A blown fuse should be replaced with a 7½-amp, type 3AG fuse only.
3. If desired, attach the microphone mounting clip to the selected mounting surface using two small screws or bolts.
4. Plug the microphone into the microphone jack located on the front left side of the unit. The microphone supplied with the unit is recommended, however, most standard high impedance ceramic microphones will work.
5. Connect the antenna to the antenna connector located on the rear panel. The unit is designed to match standard 50 ohm 2-meter amateur antennas. In the interest of good engineering practice and maximum efficiency, the antenna system should exhibit a low VSWR.

MOBILE OPERATION

1. Remove the unit from the mounting yoke.
2. With screws or bolts securely fasten the yoke in the desired location (under dash, on console, overhead, etc.). Unit performance is not affected by mounting position.
3. Replace the unit in the mounting yoke and tighten the thumbscrews.
4. Connect the color-coded power leads to the power source. Take care to use RED for positive and BLACK for negative. Unit will only operate on a supply with negative ground. If it is necessary to extend power leads, use #14 gauge or heavier insulated copper wire. If polarity is reversed the unit will be inoperative if this occurs check wiring polarity (RED to positive and BLACK to negative) and the protective fuse. A blown fuse should be replaced with a 7.5-amp, type 3AG fuse only.
5. Attach the microphone mounting clip to the desired mounting surface using two small screws or bolts.
6. Plug the microphone into the microphone jack located on the front left side of the unit. The microphone supplied with the unit is recommended, however, most standard high impedance ceramic microphones will work.
7. Connect the antenna to the antenna connector located on the rear panel. The unit is designed to match standard 50 ohm 2-meter amateur antennas. In the interest of good engineering practice and maximum efficiency, the antenna system should exhibit a low VSWR.

PORTABLE OPERATION

The easiest method of portable operation is to utilize the Genave HamPak-2 Portable Power Case. For instructions on utilization of the HamPak-2 see the instruction sheet supplied with the HamPak-2.

Portable operation of the unit requires the same considerations as fixed and mobile operations (power supply, antenna, etc.). Battery operation of the unit is possible and the low power feature reduces power drain to a minimum.



OPERATING INSTRUCTIONS

1. Turn volume (#1) and squelch control (#2) knobs completely counterclockwise.
2. Move the OFF/LO/HIGH switch (#3) to the LO position.
3. Turn the volume control clockwise to adjust the volume to the desired level.
4. Turn the squelch control clockwise until the background sounds just disappear. Don't adjust squelch when a signal is being received.
5. Select the desired frequency mode on the Mode Selector Switch (#4). The "unlocked" mode permits selection of the transmit frequency on the Transmit/Transceive frequency selector (#5) and selection of the receive frequency on the Receive frequency selector (#6). When operating in the "locked" mode prepared receive and transmit frequencies are selected on the Transceive frequency selector (#5).
6. To transmit: depress microphone button, hold microphone 4 to 6 inches from mouth, and talk in a normal voice.
7. Release the microphone button to listen.

* The GTX-200 comes with 146.940 Mhz transmit and receive crystals installed. The remaining 9 transmit and 9 receive frequencies can be installed by the owner or the factory, at a nominal charge.

MAINTENANCE

Keep the unit dry and check electrical connections regularly to insure satisfactory operation under normal conditions.

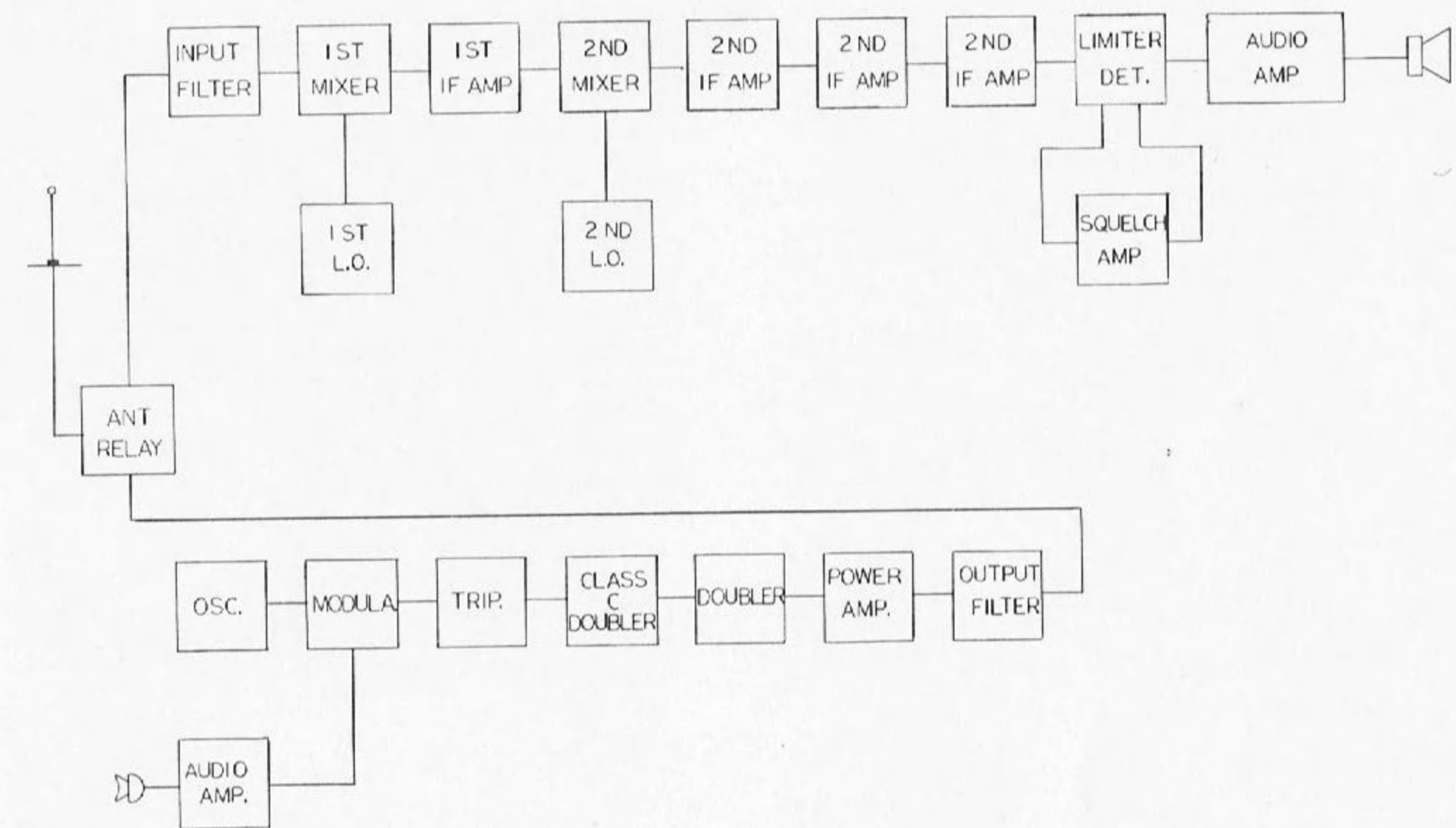

Block Diagram

THEORY OF OPERATION

INTRODUCTION

The Genave GTX-200 is a VHF FM transceiver intended for use in the amateur radio services. It transmits and receives 16F3 emission in the frequency range from 144.0 to 148.0 MHz on any one of ten possible selected transmit/receive frequency pairs. The unit provides a nominal 30 watts of output power into a 50 ohm load. The unit was designed for fixed, mobile, or portable operation.

RECEIVER

The receiver is basically a dual conversion superheterodyne type utilizing a single integrated circuit to perform the limiting and detection functions.

The received signal is applied from the antenna connector to the three pole low pass filter comprised of C270, L213, and C254. This filter also functions as a low pass filter for the transmit function. The signal from the low pass filter is applied to pin 15 of K201, the T/R relay. In the receive mode the signal is fed to the input filter of the receiver via pin 14 of the T/R relay.

The receiver input filter consists of L101, L102, and L103 and their associated tuning and coupling capacitors. The output of the input filter is capacitively coupled to the base of Q101, the first mixer.

The first local oscillator consists of Q107 and associated circuitry. The desired crystal in the 43.633 to 44.966 MHz range is selected by means of the frequency selection switches, SW202B or SW203. The collector circuit of Q107

is tuned to the third harmonic of the crystal frequency and the 130.89 to 134.89 MHz output is capacitively coupled to the base of Q101.

The 13.1 MHz difference signal produced in the first mixer is coupled to the first IF amplifier consisting of Q102 and associated circuitry. The output of the first IF amplifier is fed to Q103, a dual gate FET which together with its associated circuitry functions as the second mixer.

The second local oscillator consists of Q111 and associated circuitry. The second local oscillator operates at the crystal controlled frequency of 12.645 MHz. This 12.645 MHz signal produced is mixed with the 13.1 MHz signal from the first IF in the second mixer. The 455 KHz difference frequency produced by the second mixer is applied to the second IF amplifiers of Q104, Q105, Q106, and their associated circuitry.

The 455 KHz second IF signal is applied to pins 1 and 2 of IC101. IC101 performs the limiting and detection functions in the receiver. C130 sets the de-emphasis level in the detection circuitry. T111, R136, and C132 form the quadrature detector transformer circuit. Detected audio is fed from pin 8 of IC101 through C133 and R121 to the audio amplification circuits via pin 14. Detected audio from pin 8 is also fed to the noise amplifier consisting of Q109 and associated circuitry. The amplified noise from Q109 is fed to the voltage doubling detector of CR101, CR102, and C137. The detected noise level is fed to the base of Q110. R127, the squelch control, controls the authority of the detected noise level on the base of Q110. As Q110 begins to turn on, the audio level at the output (pin 12) of IC101 is reduced.

R129, the volume control, sets the level of audio fed to IC102, the audio amplifier. R130 and C140, and R131 and C141 perform the frequency response shaping of the audio amplifier while C143, C144, and C147 provide feedback to various stages within IC102. Output audio from IC102 is applied from pin 12 through C146 to the speaker.

TRANSMITTER

The modulator audio amplifier in the unit is built around a single integrated circuit, IC201. This IC is a dual operational amplifier and is shown on the schematic diagram as IC201A and IC201B. The audio output of the ceramic microphone is amplified by IC201A. A 6 db/octave rising characteristic is given to the audio frequencies by loading the 1500 pfd microphone capacitance with the bias resistors R231 and R232. IC201 also provides the clipping function required for limiting the modulation by saturating symmetrically against the supply voltage and ground. The regulated supply voltage for the modulator is obtained by applying 13.75 VDC primary power through R253 and across a 6.8 volt zener diode, CR206.

The output from IC201A is applied to IC201B which acts as an active, 2-pole, Chebyshev low pass filter with a cutoff frequency of 3 KHz. R238 and C266 add a third pole to the filter give the required -18 db/octave rolloff above 3 KHz.

R239 controls the audio level applied to the modulator varactor diode, CR202. R207 and C215 convert the audio signal applied to the modulation diode to the form required to produce phase modulation.

DC bias for the modulation diode is provided by IC201B through R238, R239, and R207. The audio return from R239 is provided by C267.

Q201 is the oscillator transistor and accordingly generates the required RF signal. Power for the oscillator is derived from an independent voltage regulator (R201 and CR210). The oscillator is a basic Colpitts or Clapp crystal circuit. Variable capacitors are used in series with each crystal to allow exact setting of the generated frequency. Output from the oscillator is from 12.00 MHz to 12.33 MHz. The oscillator output is multiplied by 12 in the multiplier stages resulting in a final output frequency from 144.00 to 148.0 MHz.

Frequency modulation of the carrier signal is accomplished by CR202. A signal from Q201, the oscillator transistor, is applied to CR202 by a tuned transformer, T201. As an audio signal is applied to the varactor diode, CR202, from the modulation audio amplifier; the capacitance of the diode changes thus varying the resonant frequency of the tuned transformer, T201. This results in phase modulation of the carrier signal. The audio signal is de-emphasized before application to CR202, however, resulting in frequency modulation of the carrier rather than phase modulation.

The output of the modulator is first applied to Q202, an RF tripler. In this stage the input frequency of 12.2 MHz is multiplied to 36.6 MHz. Other harmonics and subharmonics are filtered out by a double-tuned transformer, T202.

The output of T202 is fed to Q203, a Class C doubler, which increases the signal frequency to 73.2 MHz. The undesired signals generated in this stage are removed by the tuned transformer, T203.

The output of T203 is applied to the base of Q204, the last multiplier stage. Q204 doubles the signal frequency to 146 MHz. The output of Q204 is matched to the input of Q205 by a resonant "L" section consisting of L201 and C230. This circuit also provides some degree of subharmonic suppression.

The power amplifier in the transmitter consists of Q205, Q206, Q207 and associated circuitry. This complement of devices increases the output from Q204, nominally 50 milliwatts, to the rated output of the transmitter, 30 watts. Frequency selective matching networks are used between each of the stages to effectively couple power between devices and to reject the unwanted spurious responses from the desired signal.

SW201A switches R224 into a series connection between the collector supply and Q206 when the switch is in the "LO" position. This reduces the output power of the transmitter to approximately 1 watt for short distance, low power drain operation.

A relatively complex filter is used to remove subharmonic spurious outputs and harmonic radiations from the RF signal prior to transmission. C246, C247, L207, and C248 comprise a resonant matching network which matches the output of Q207 to the 50 ohm antenna impedance. The remainder of the components up to the output connector form an elliptic function, low pass filter which reduces the level of all spurious outputs, above the output frequency, to less than -13 dbm.

CRYSTAL SWITCHING

Crystal switching for the transmit and receive oscillators is accomplished through the use of switches SW202, SW203, and SW204. SW202A selects the desired transmit frequency by placing the appropriate transmit crystal and trimmer in shunt with the base circuit of Q201, the transmit oscillator.

SW204 connects either SW202B or SW203 to the base circuit of the receive oscillator, Q107. In the "unlocked" mode SW203 is connected to the base circuit of the receive oscillator and connects the receive crystals in shunt with the oscillator base circuit. When operating in the "unlocked" mode the 0 position of the receive frequency selector, the receive crystal in the A position on the printed circuit board is placed into operation (See figure 7). The 9 position of the receive selector connects the receive crystal in the J position on the printed circuit board to the receive oscillator circuit.

In the "locked" mode SW202B is connected to the oscillator base circuitry, and since this switch is mechanically connected to the transmit selector, allows the positioning of the Transmit/Transceive frequency selector to select the receive crystal. When the Transmit/Transceive switch is in the 0 position it selects the transmit and receive crystals in the A position on the printed circuit board (See figure 7). In the 9 position of the Transmit/Transceive switch the crystals in the J position on the printed circuit board are selected.

PRIMARY POWER

Power to operate the unit is supplied from the 13.75 VDC external power source via the input connector, F201, and SW201B. The 13.75 VDC line supplies power to operate the relay, K201; the panel backlighting lamp, DS101 and the transmitter and receiver circuitry, via Pins 11, 12, and 13 of K201.

The transceiver is protected against a reversed polarity input voltage by means of CR203 and CR205. CR204 prevents the feedback of induced voltage spikes generated by K201, on the 13.75 VDC line. C268 acts as a filter on the 13.75 VDC line.

ALIGNMENT PROCEDURE

GENERAL

The unit comes prealigned from the factory and realignment should never be necessary during the normal life of the unit unless components within the unit have been replaced due to damage.

NEVER attempt to realign the circuitry of the unit unless the test equipment specified for each section is available.

RECEIVER ALIGNMENT

PREPARATION

To properly align the receiver of the unit the following test equipment or its equivalent is required:

- Oscilloscope, DC—8MHz, DC coupled, Calibrated vertical attenuator, (Heath-kit 10-14, or equivalent).
- RF Signal Generator, 13.1 MHz, 144 MHz, and 148 MHz.
- Sweep Signal Generator, Must be capable of sweeping the frequency range 143 to 149 MHz.
- FM Signal Generator, Must cover the frequency range 144 to 148 MHz with a deviation of at least 5 KHz at 1000 Hz.
- Frequency Counter, DC—150 MHz.
- AC VTVM, any accurate instrument.
- DC Power Supply, low ripple.

To facilitate test-equipment connections to the receiver during alignment, short pieces of wire can be soldered to the bottom of the receiver board at the following points:

Secondary pins of T110 (455 KHz output transformer)

Pin 3 of T102 (13.1 MHz output coil)

Tap of L103 (RF filter output coil)

Emitter of Q101 (1st mixer transistor)

Select 146.940 MHz and turn the volume and squelch controls fully counterclockwise.

Connect the transceiver to a 13.75 VDC, filtered power supply.

455 KHz IF ALIGNMENT

- Connect the scope vertical input to the secondary of T110 with a length of co-ax cable. Set the scope vertical attenuation for maximum sensitivity.
- Connect the RF output of the RF signal generator to the frequency counter, and set the frequency to exactly 13.1 MHz, unmodulated.
- Disconnect the frequency counter, and connect the RF output of the Signal Generator between Pin 3 of T102 and receiver ground.
- Turn the transceiver power switch on, and adjust the Signal Generator RF attenuator and scope controls to give a usable pattern of the 455 KHz IF signal.

NOTE: Small changes in the amplitude of the IF signal are more easily seen if the attenuator on the signal generator is kept set so that the IF signal covers about $\frac{3}{4}$ of the scope screen vertically, and the scope internal sweep is set slow enough to display a large number of IF cycles.

- Tune the cores of 455 KHz IF transformers T110, T109, T108, T107, T106, T105, T104, and T103 (in that order) for maximum amplitude on the scope. Reduce signal generator attenuator as necessary to keep a usable presentation on the scope.
- Turn the transceiver power switch OFF, and disconnect the RF cable of the signal generator from Pin 3 of T102. Check that the signal generator is still set exactly to 13.100 MHz.

13.1 MHz IF ALIGNMENT

- Connect the RF cable of the signal generator between the tap of L103 and ground. Leave oscilloscope connected as above.
- Turn the transceiver power switch on, and reduce the setting of the signal generator RF attenuator to keep a usable presentation on the scope screen.
- Adjust the bottom core of T102 for maximum amplitude, then adjust the top core of T102 for maximum amplitude. Adjust bottom and top cores of T101 for maximum amplitude.
- Adjust all four cores in this manner, until no further increase in amplitude can be obtained.

- Turn the transceiver power switch OFF, and disconnect the oscilloscope and the signal generator from the transceiver.

RF-INPUT FILTER ALIGNMENT

- With the transceiver still off, connect the RF output cable of the sweep generator to the transceiver ANT connector. Connect the vertical input of the oscilloscope between the emitter of Q101 and transceiver ground.
- Set the sweep generator to sweep from 143 MHz to 149 MHz. Use the RF signal generator as a marker generator to produce 144 and 148 MHz markers.
- Turn the transceiver power switch on.
- Set the scope vertical attenuator to the most sensitive position, and set the RF output of the sweep generator low enough to prevent over driving the RF input filter.
- Adjust C101, C103, and C105 to give a 4 MHz bandpass similar to that shown in figure 1.
- Turn the transceiver power switch off, and disconnect the test equipment from the transceiver.

OSCILLATOR COIL ADJUSTMENT

CAUTION: Never depress the microphone push-to-talk button while a signal generator is connected to the ANTENNA connector, as the transmitter power would damage the RF attenuator.

- Using the frequency counter, set the FM signal generator exactly to 146.940 MHz. Disconnect the frequency counter from the FM signal generator RF cable and connect the RF cable to the transceiver ANTENNA connector. The FM signal generator RF attenuator should be set to the minimum position, and the modulation should be off.
- Set the AC VTVM, or other DB meter, to a convenient range, such as -10 db, and connect the meter leads across the speaker voice coil.
- The transceiver frequency selector should be set to 146.940 MHz and the squelch and volume controls turned fully counterclockwise.
- Turn the transceiver power switch on.
- Adjust the volume control clockwise until the receiver background noise indicates -10 db on the AC VTVM. Increase the setting of the FM signal generator RF attenuator until the receiver background noise drops to approximately -27 db (17 db quieting).
- Adjust the RF filter capacitor, C105, for maximum quieting (Minimum indication on the AC VTVM).
- Tune the core of the oscillator coil, L104, for maximum quieting. If necessary, reduce the output of the signal generator, to keep a readable indication on the DB meter.
- Turn the transceiver power switch off, but leave the FM signal generator and DB meter connected to the transceiver.

DETECTOR TRANSFORMER ADJUSTMENT

- Connect the oscilloscope vertical input cable across the speaker voice coil, paralleling the AC VTVM leads.
- Check to insure that the FM signal generator is still set to 146.940 MHz. Set the signal generator modulation for 5 KHz deviation at 1 KHz. The signal generator RF attenuator should be set in the vicinity of 2 microvolts.
- Turn the transceiver power switch on, and adjust the scope controls to give a readable display of the 1 KHz modulation.
- Adjust the core in the discriminator transformer, T111, for best linearity of the 1 KHz signal. The AC VTVM and the scope will show maximum amplitude of the 1 KHz modulation at this point.
- The receiver is correctly aligned now, and the sensitivity for 20 db quieting may be checked. Leave the test equipment connected to the transceiver.

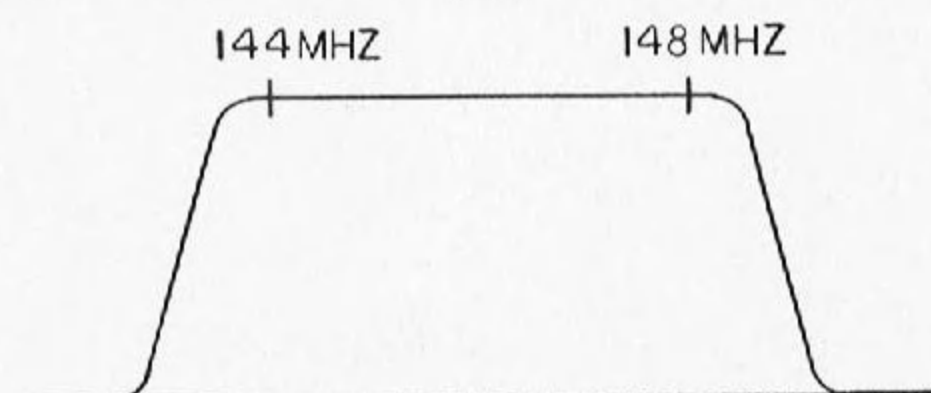

Swept Input Filter
Figure 1

RF INPUT FOR 20 DB QUIETING

1. Turn the FM signal generator modulation off, and ascertain that the generator is set exactly to 146.940 MHz. Set the FM signal generator RF attenuator for minimum output.
2. Check that the transceiver is set on 146.940 MHz. Adjust the transceiver volume control so that the receiver background noise indicates -10 db on the AC VTVM.
3. Slowly increase the setting of the FM signal generator RF attenuator, until the AC VTVM indicates -30 db. Note the RF level shown on the FM signal generator attenuator. This is the RF input required to produce 20 db receiver quieting. Normally, an input of -109 dbm (0.8 uvolt) to -112 dbm (0.55 uvolt) will quiet the receiver 20 db.
4. Check the receiver quieting with the transceiver and signal generator on each additional frequency installed in the unit. On each frequency the receiver should quiet 20 db with an input of -109 dbm (0.8 uvolt) to -112 dbm (0.55 uvolt).

SQUELCH OPERATION

1. Set the signal generator on 146.940 MHz, and set the modulation for 5 MHz deviation at 1 KHz. Set the RF attenuator for minimum RF output.
2. Set the transceiver on 146.940 MHz, and turn the squelch control fully clockwise. The receiver audio control should be set for maximum volume. The receiver is now fully squelched, and should be completely silent.
3. Reduce the DC input voltage to approximately 11 volts, and note that the receiver is still fully squelched. Return DC input to 13.75 VDC, and set volume control at midrange.
4. Increase the setting of the signal generator RF attenuator until the squelch just fully opens. The RF attenuator should show -111 dbm (0.6 uvolt) or better.
5. Repeat the above steps for each additional frequency installed in the unit. On each frequency, the squelch should open at approximately -110 dbm or better.

AUDIO OUTPUT POWER

1. Set the FM signal generator on 146.940 MHz, and set the modulation for 5 KHz deviation at 1 KHz. Set the RF attenuator in the vicinity of 5 microvolts.
2. Set the transceiver on 146.940 MHz and turn the volume control fully clockwise. The AC VTVM should indicate not less than 2.83 volts (1 watt).
3. Set the signal generator for 5 KHz deviation at 400 Hz, and note that the AC VTVM indicates at least 2.83 volts with the transceiver volume control fully clockwise.
4. Set the signal generator for 5 KHz deviation at 3 KHz. Again the AC VTVM should indicate at least 2.83 volts at maximum setting of the transceiver volume control.
5. Turn off the transceiver power switch, and disconnect the AC VTVM and oscilloscope from the transceiver.

FREQUENCY MEASUREMENT

To insure that the receiver will operate on the correct frequency, each high frequency oscillator crystal frequency should be measured. The frequency should be within plus or minus .003% of the frequency stamped on the crystal case divided by 3.

$$\text{Tolerance} = \pm (.003\%) \times \frac{\text{Stamped Frequency}}{3}$$

Example: for 146.940 MHz

$$\text{Tolerance} = \pm (.003) \times \frac{146.940 \text{ MHz}}{3}$$

= 1.469 KHz

Connect the frequency counter to the transceiver with a short length of coax cable. The braid should be connected to the transceiver chassis, and the inner-conductor should be connected to the tap (pin 3) of the oscillator coil, L104.

1. Turn the transceiver power switch on.
2. Select 146.940 MHz and read the crystal frequency, which should fall within the range listed above.
3. Repeat these steps for each receive frequency installed in the unit.
4. Turn off power switch, and disconnect frequency counter.

RECEIVER PREAMPLIFIER

DESCRIPTION

The receiver preamplifier consists of a single N-channel dual-gate MOS FET RF amplifier with LC tuned input and output. The input and output are LC coupled to 50 ohm coaxial cables which connect to the receiver circuit board. The broadband preamplifier circuitry provides a nominal 6 to 9 db of additional gain over the receiver tuning range. All power necessary for operation of the preamplifier is provided by the transceiver.

The entire preamplifier is constructed on a 1 inch by 1.4 inch epoxy-fiberglass circuit board. The preamplifier is enclosed on four sides by a tin-plated steel enclosure which is predrilled on one side for convenient mounting.

The information herein contained can be used to install the receiver preamplifier in Genave transceivers which are not so equipped. If your transceiver has the receiver preamplifier presently installed this information is intended to assist you should maintenance ever be required.

INSTALLATION PROCEDURES

1. Remove the transceiver from its protective case.
2. Using a knife or similar instrument, carefully cut the receiver input track and relay ground connection in the appropriate locations as shown in Figure A.
3. Remove the speaker from its mounting tabs.
4. Drill the appropriate holes in the circuit board as shown in Figure A. The two holes for the preamplifier input and output cable grounds should be drilled with a 1/16 inch diameter drill. The remaining three holes should be drilled with a #60 (.040 inch diameter) drill.
5. Prepare the preamplifier input and output cables, insert them into their appropriate circuit board holes and solder them in place (See Figure B).
6. Insert the red preamplifier A+ lead into its appropriate hole in the circuit board and solder.
7. Place the predrilled side of the preamplifier case over the speaker mounting tab located on the siderail closest to the power lead grommet. Secure the preamplifier in place between the speaker and the speaker mounting tab using the speaker mounting screw (See Figure D). Replace the other speaker mounting screw.
8. Reinstall the transceiver in its protective case.

CIRCUIT BOARD CONNECTIONS

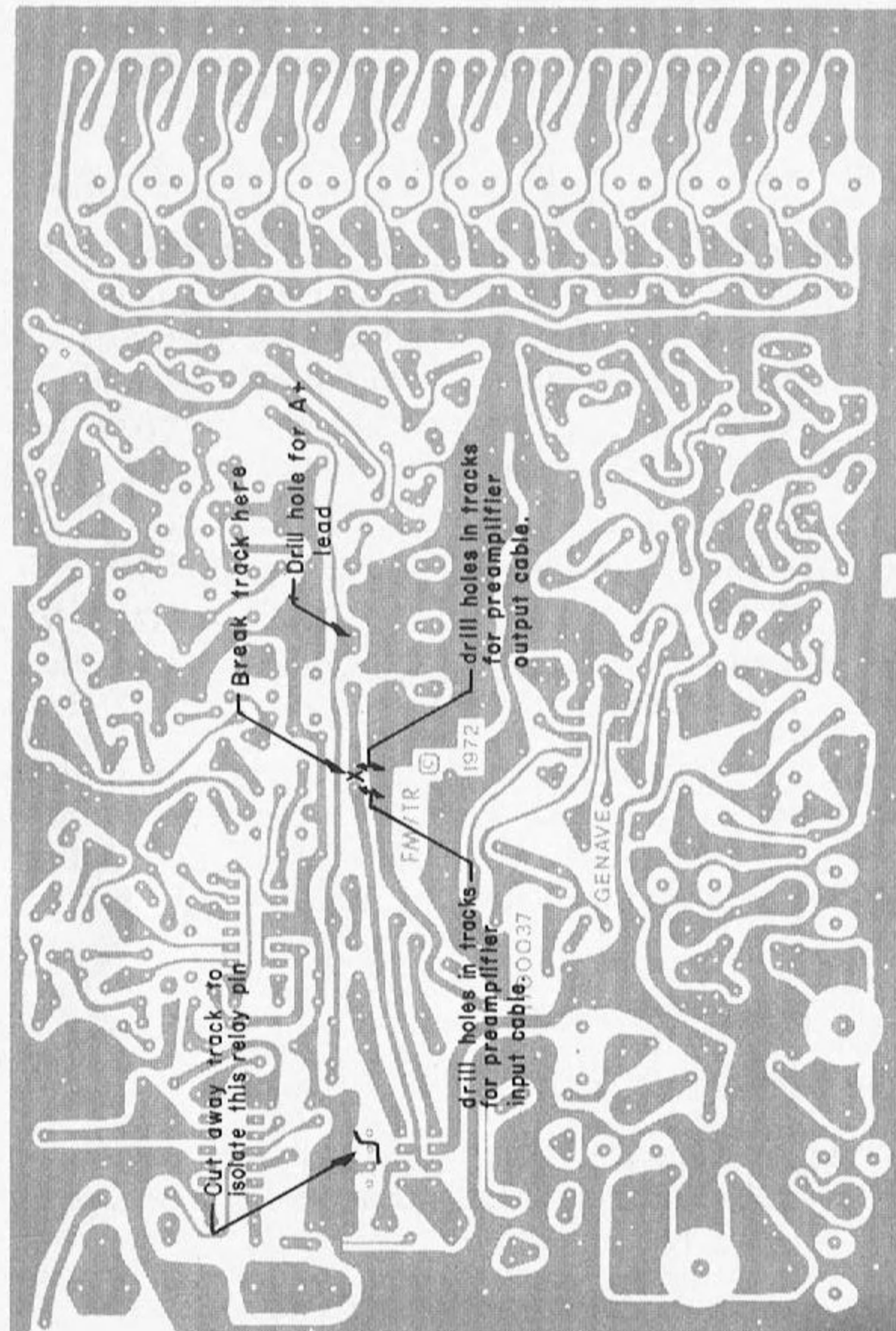

Figure A

CABLE CONNECTIONS

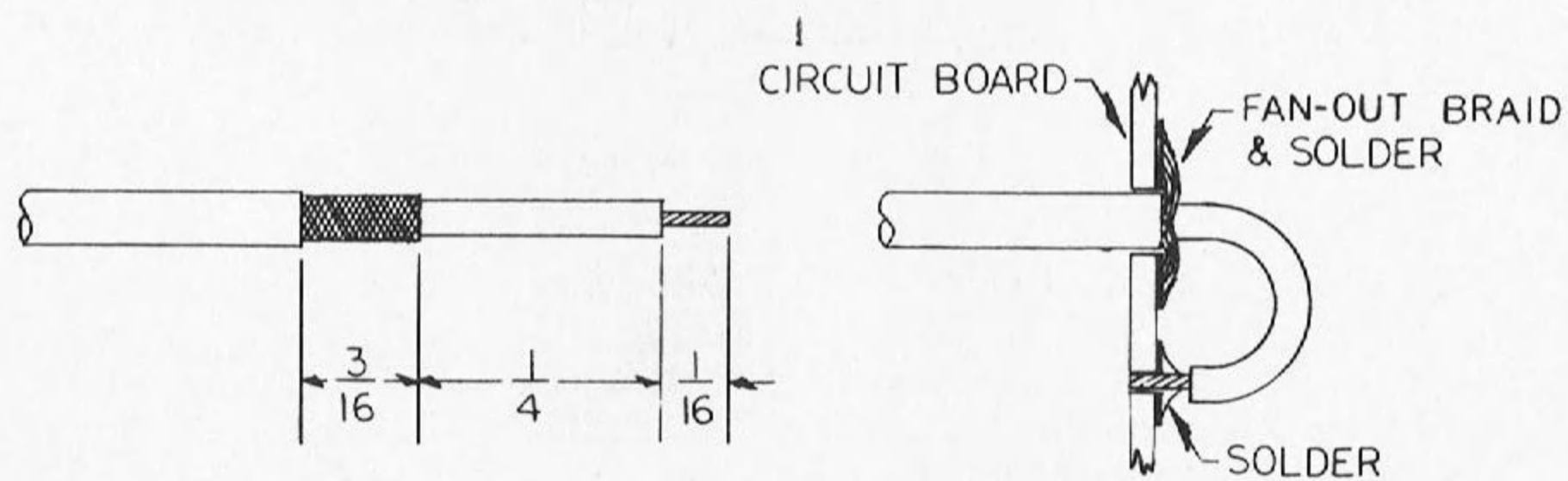

Figure B

MOUNTING LOCATION

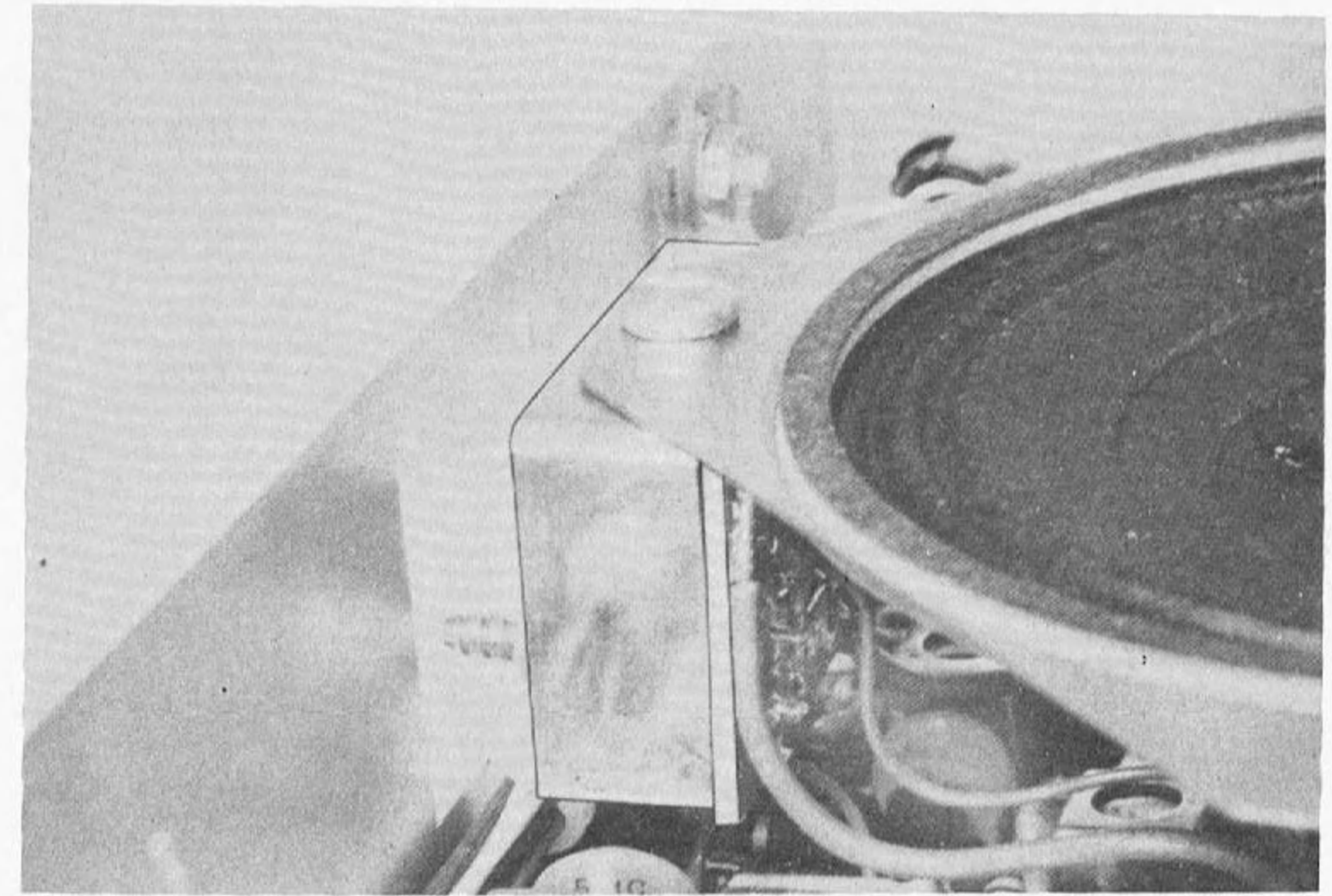

Figure C

ALIGNMENT PROCEDURES

1. Set receiver to a frequency at approximate center of receiving range.
2. Apply a signal to receiver input at a low level such that noise is heard on the received audio.
3. By alternately tuning C302 and C304 and by reducing the applied signal level tune the preamplifier for minimum noise on the received audio.

NOTE: The above alignment may be performed using either a signal generator or "on-the-air" signals.

SCHEMATIC DIAGRAM

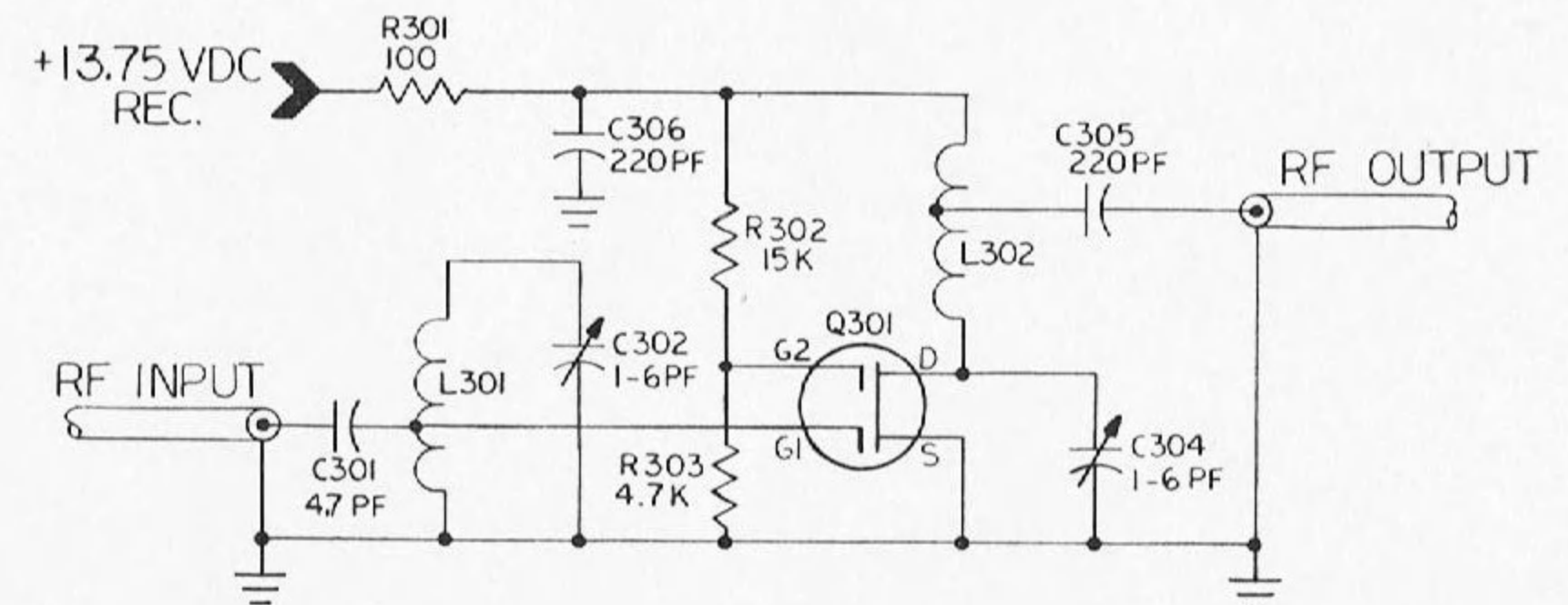

Figure D

PARTS/TRACK MAP

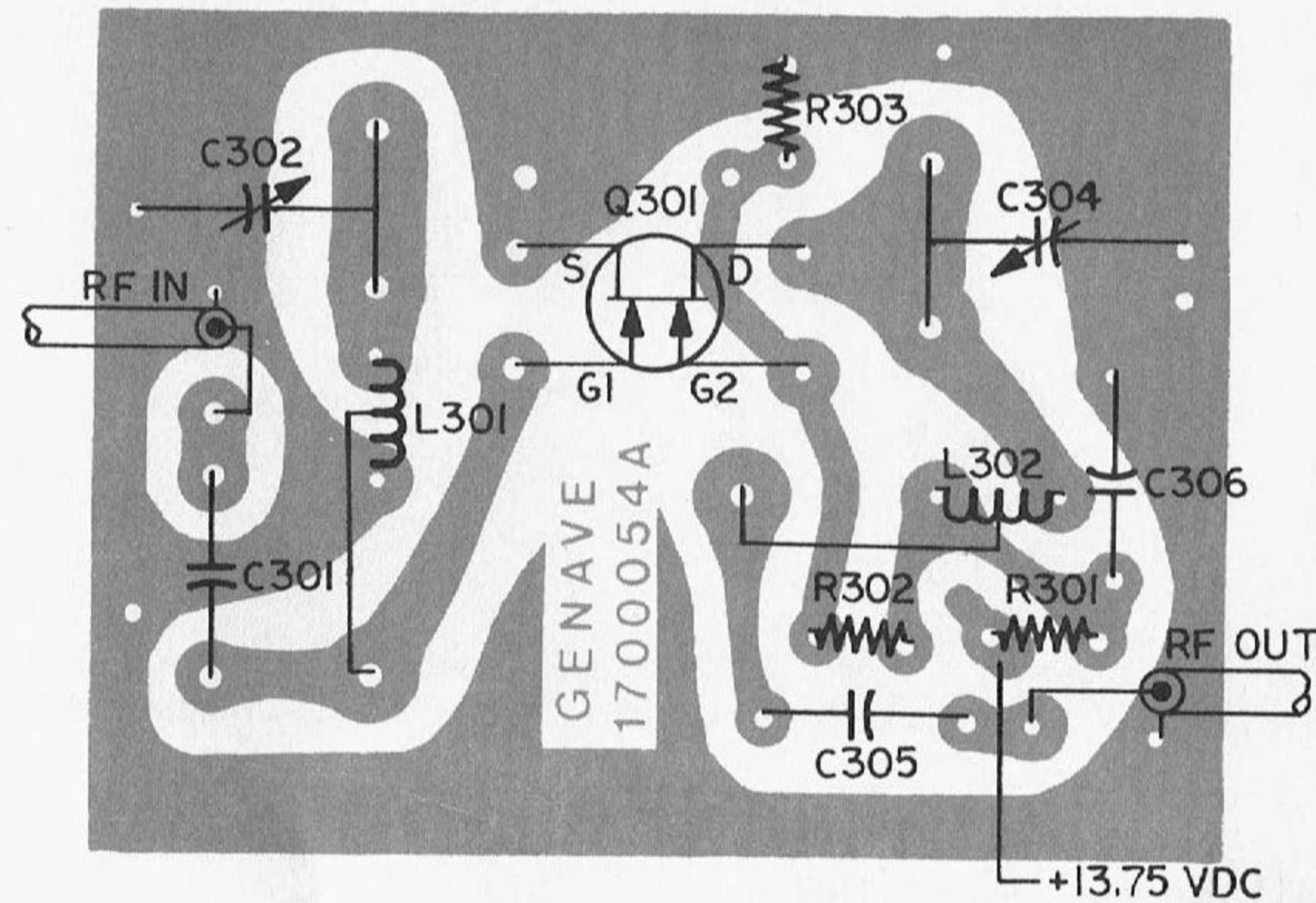

Figure E

PREAMPLIFIER PARTS LIST

Ref. No.	GENAVE Part No.	Description
CAPACITORS		
C301	1520004	NPO Disc, 4.7 pfd, 10%
C302	1570120	Trimmer, 1-6 pfd
C303	1520033	Z5F Disc, 220 pfd, 10%
C304	1520120	Trimmer, 1-6 pfd
C305	1520033	Z5F Disc, 220 pfd, 10%
COILS		
L301	1800073	R.F. Input
L302	1800074	R.F. Output
RESISTORS		
R301	4710008	100 ohm, 10%, 1/4W
R302	4710030	15K, 10%, 1/4W
R303	4710025	4.7K, 10%, 1/4W
SEMICONDUCTORS		
Q301	4800054	Dual Gate, N-Channel, MOS-FET, MPF-120 or 3N201

TRANSMITTER ALIGNMENT

PREPARATION

To properly align the transmitter the following test equipment or its equivalent is required:

- Power Meter, 35 watts @ 148 MHz, or relative output indicating device, (See figure 4.) with 50 ohm dummy load.
- Frequency Counter, DC—150 MHz, or other accurate frequency measuring device.
- Deviation Meter, to read ± 7.5 KHz.
- Power Supply, 13.75 VDC at 8 amp minimum, filtered.
- VTVM. Any accurate instrument.
- Audio Generator, 1700 Hz.

To prepare the unit for alignment perform the following steps:

- Attach a 50 ohm dummy load to the RF output connector through a power meter or relative output indicating device (figure 4).
- Set the OFF/LO/HIGH switch to the HIGH position.
- Preset the deviation potentiometer to its lowest setting (potentiometer rotated toward the receiver 3-pole input filter capacitor trimmers).
- Connect the unit to a 13.75 VDC power source.

FREQUENCY AND POWER ALIGNMENT

- Select 146.940 MHz.
NOTE: The signal peak voltage measurements in the following steps of this section were made with a VTVM and DC probe. Key the transmitter *only* when adjustments are being made.
- Connect the DC probe to the emitter of Q202, key the transmitter and adjust the single slug of T201 for a peak at 12.245 MHz. Adjust the VTVM attenuator for an on-scale reading.
NOTE: T201's slug will peak in two places . . . the peak with the slug closest to the printed circuit board is correct. The peak should reach about 1.4 volts.
- Move the DC probe to the emitter of Q203. Key the transmitter and adjust the 2 slugs of T202 for a peak, centered on 36.74 MHz. Each slug should adjust between the winding and the outside end of the coil form. The signal should peak at about 0.38 volts.
- Adjust T203 by connecting the DC probe to the emitter of Q204, keying the transmitter, and adjusting the 2 slugs of T203 for a peak centered on 73.47 MHz. Each slug should adjust between its winding and the outside end of the coil form. The signal should peak at about 1.2 volts.
- If the relative output indicating device of figure 4 is used, connect the VTVM DC probe to the relative output terminal. Otherwise, observe the wattmeter or other relative output indicator.
- Preset C235 by tightening the adjustment screw down firmly and backing it off 1/2 turn.
- Key the transmitter and adjust C230, C234, C235, C239, C243, C247, and C248 for maximum relative output indication on 146.940 MHz. This step may be repeated if necessary.
- With the 146.940 MHz still selected and the OFF/LO/HIGH switch in the HIGH position, key the transmitter and adjust C203, the 146.940 MHz crystal netting trimmer, for a frequency reading of 146.940 MHz on the frequency measuring device.
- Repeat the above procedure for each transmit crystal installed in the unit, adjusting its respective netting trimmer for the frequency stamped on the top of the crystal case.

POWER MEASUREMENT PROCEDURE

- Select 146.940 MHz.
- Key the transmitter and note the transmitter power reading on 146.940 MHz. It should be no less than 25 watts.
- Repeat the above step for each transmit frequency installed.
- Set the OFF/LO/HIGH switch to the LO position.
- Key the transmitter and note the transmitter power reading on 146.940 MHz. The power level on the LO position is factory adjusted to approximately 1 watt. This level can be changed by adjusting the value of R224.
- Repeat the above step for each transmit frequency installed.

CARRIER DEVIATION ADJUSTMENT

1. Depress the 146.940 MHz pushbutton.
2. Set the OFF/LO/HIGH switch to the LO position.
3. Connect the deviation meter to the frequency measuring output of the relative output indicating device.
4. Feed an audio signal of 1700 Hz into the transceiver microphone.
5. Key the transmitter, observe the frequency deviation meter, and increase the microphone audio input until no further increase in deviation is indicated. The modulator stage is now saturated.
6. With the frequency deviation meter set to either + or - deviation, key the transmitter and adjust the slug of T201 for a peak reading. The deviation potentiometer, R239, can be adjusted for an on-scale reading of the deviation meter.
7. Set the deviation potentiometer, R239 for a deviation reading of 5 KHz. Switch the deviation meter to the + and - positions and check the amount of deviation in each position.
8. If a difference exists between + and - deviation levels adjust T201 by rocking the slug slightly until the two levels are brought into balance. The difference in deviation levels should not exceed 0.4 KHz.

FREQUENCY CHANGES

GENERAL

To add an additional receive frequency to the unit it is only necessary to install the additional receive crystal. When a transmit crystal is added it will be necessary to adjust the corresponding netting capacitor to center the transmitter on the desired frequency. A single receive or transmit crystal can be used in more than one frequency selection position. This is accomplished by a simple wiring addition which allows the same crystal to operate when either of the selected frequency pushbuttons is depressed. The following information describes how to select the necessary crystals, when installing additional frequencies and how to wire the unit to utilize a single crystal for more than one receive/transmit frequency pair.

CRYSTAL SELECTION

The receive and transmit crystals used in the unit must meet the following specifications:

Transmit

Parallel Mode: $C_p = 20$ pfd.

Fundamental Cut

Tolerance: $\pm .002\%$

$$\text{Crystal Frequency} = \frac{\text{Operating Frequency}}{12}$$

*(eg.) Operating Frequency = 146.940 MHz
Crystal Cut Frequency = 12.245 MHz

Receive

Parallel Mode: $C_p = 39$ pfd.

Third Overtone

Tolerance: $\pm .003\%$

$$\text{Crystal Frequency} = \frac{\text{Operating Frequency} - 13.1 \text{ MHz}}{3}$$

*(eg.) Operating Frequency = 146.940 MHz
Crystal Frequency = $\frac{146.940 - 13.1 \text{ MHz}}{3} = 44.613333 \text{ MHz}$

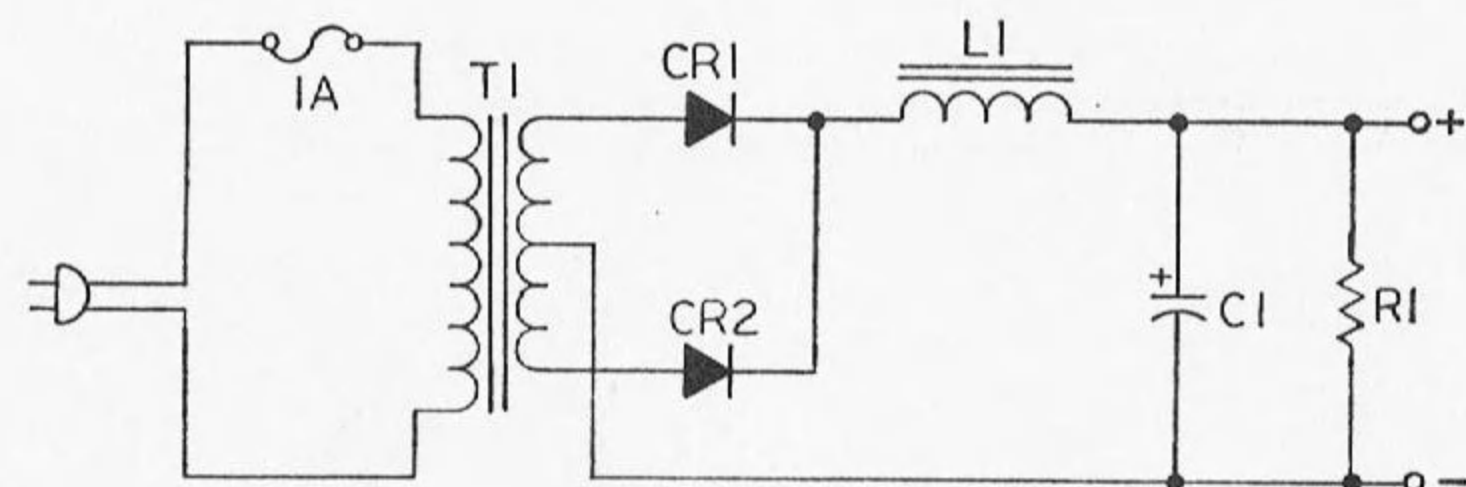

C1—29,000MFD, 25VDC, MALLORY CGS293U025V4C3PH OR EQUIVALENT—GENAVE PART NO. 1550014—PRICE \$ 5.45

DI,D2—6.0A, 50 PRV, SILICON—IN349I, INI314, 20F10, ETC.—GENAVE PART NO. 4812111—PRICE \$1.22 EACH

T1—120 VAC PRI: 34 V C.T. SEC @6A—GENAVE PART NO. 5600037—PRICE \$15.48

L1—SAT. CORE REACTOR, .25 MHY, 100 MILLIOHM—GENAVE PART NO. 1800210—PRICE \$ 8.04

RI—47 OHM, 10W, WIREWOUND—GENAVE PART NO. 4740028—PRICE \$.36

THE ABOVE PARTS ARE AVAILABLE FROM GENAVE BY MAILING CHECK OR MONEY ORDER ALONG WITH GENAVE PART NUMBER OF DESIRED PARTS.

Figure 2
AC Power Supply

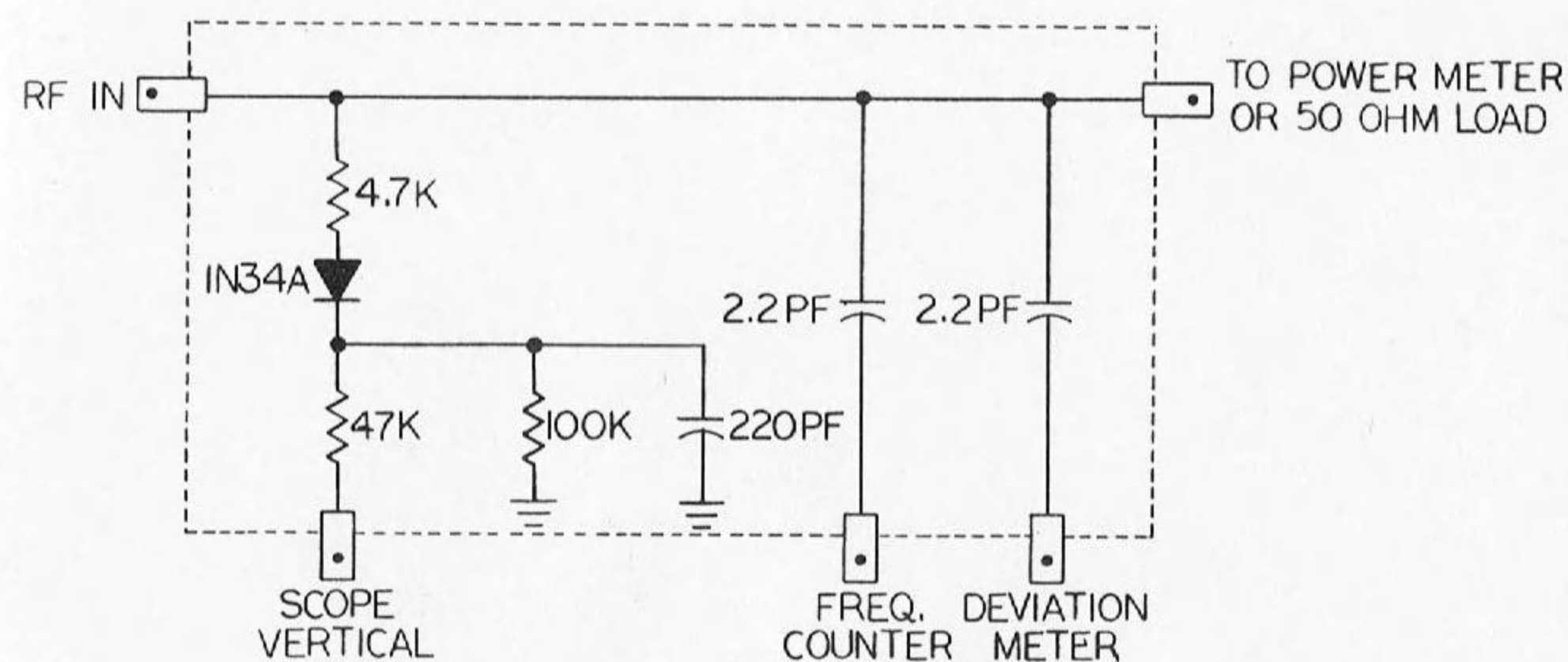

Figure 3
Relative Output Indicator

Mainboard Schematic Figure 6

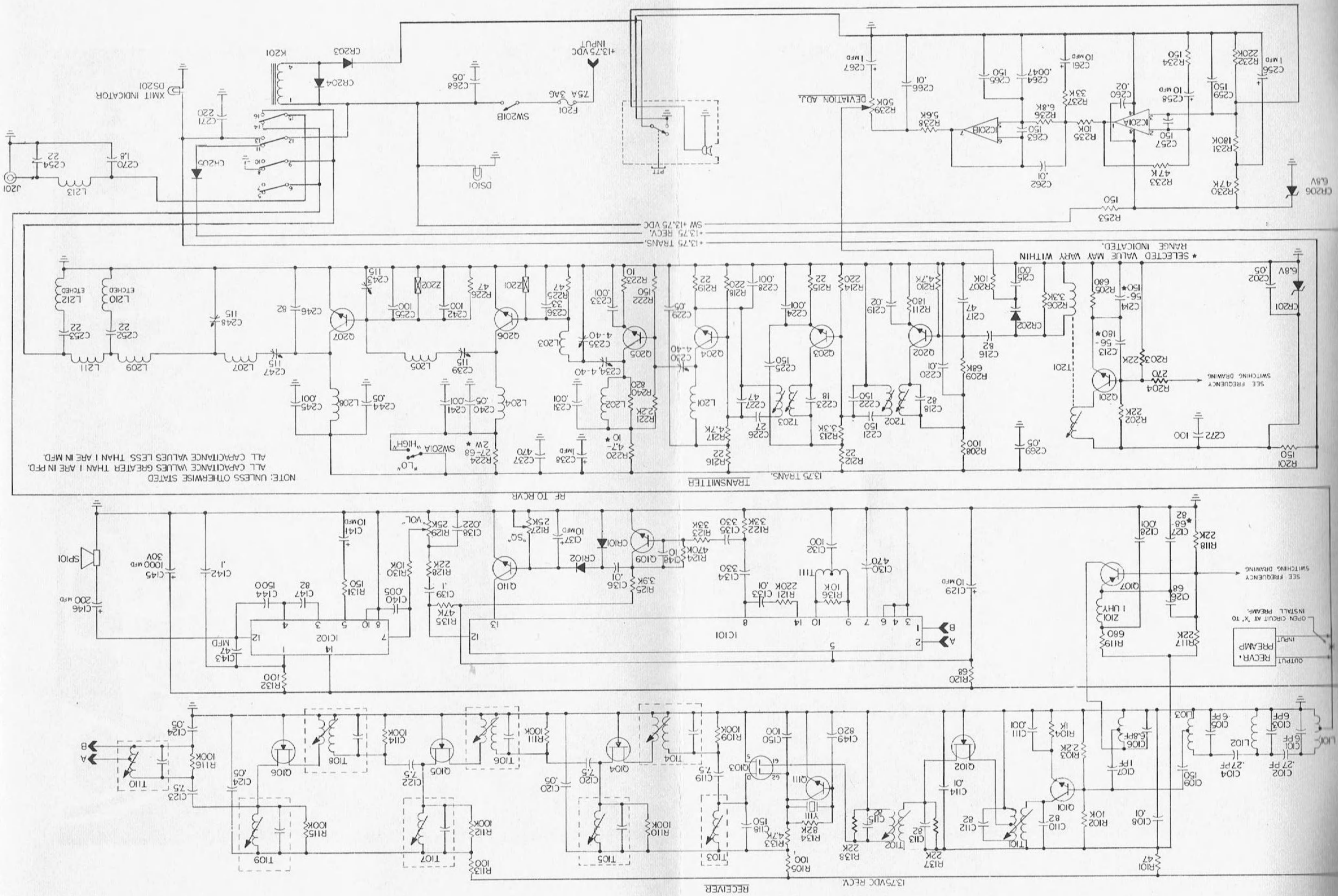

Figure 5
Series 170037L Board & Later

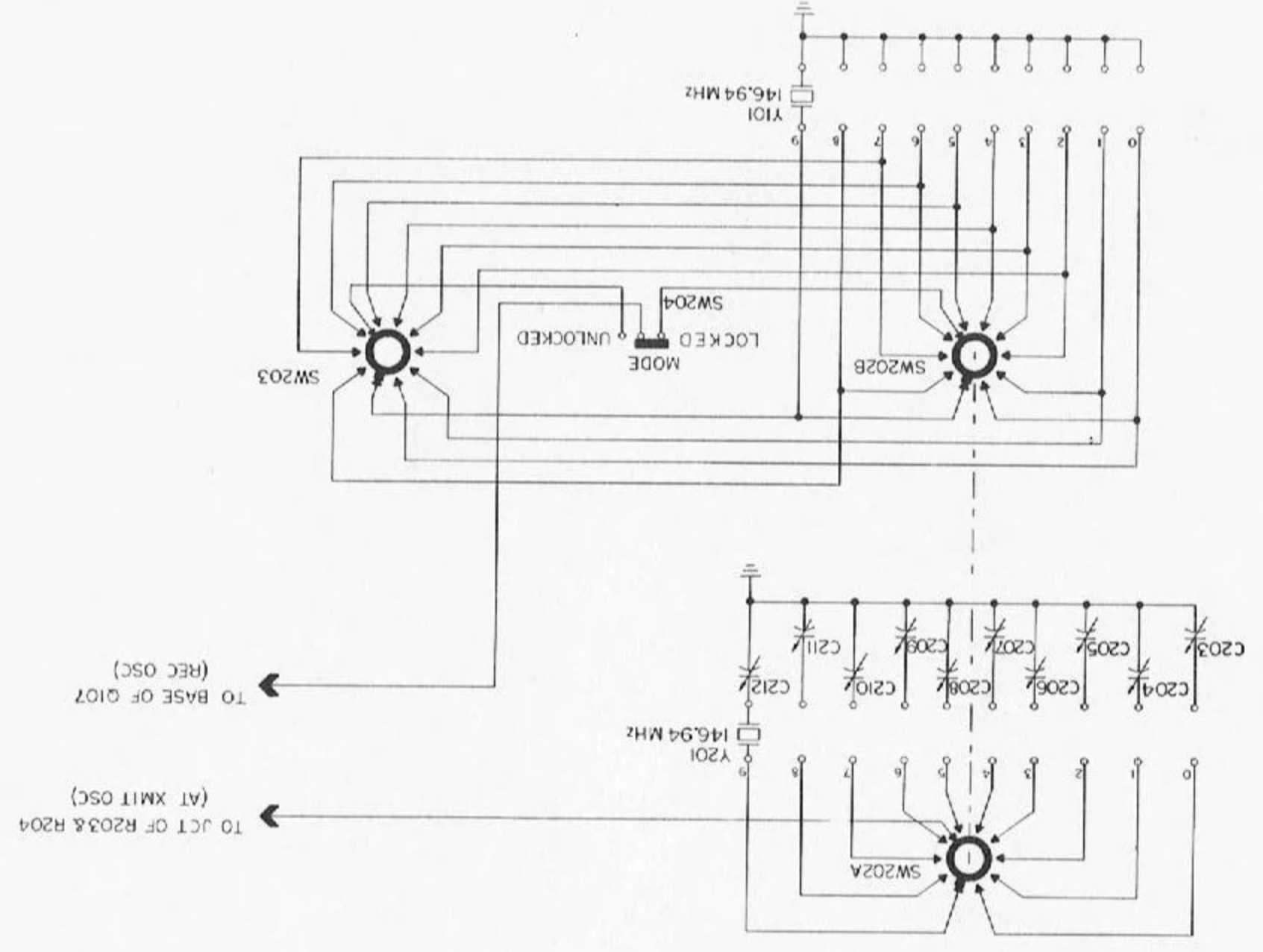
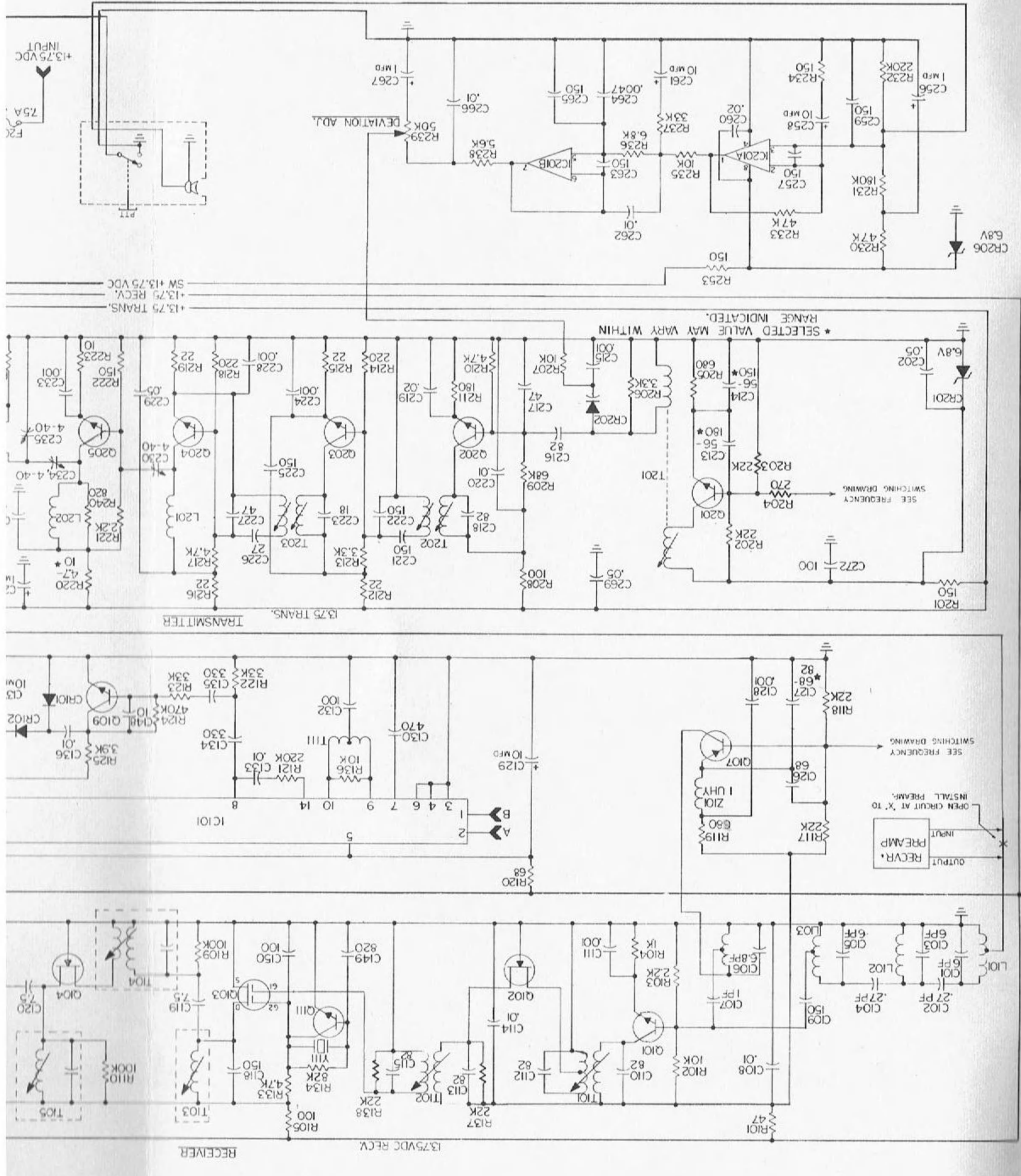
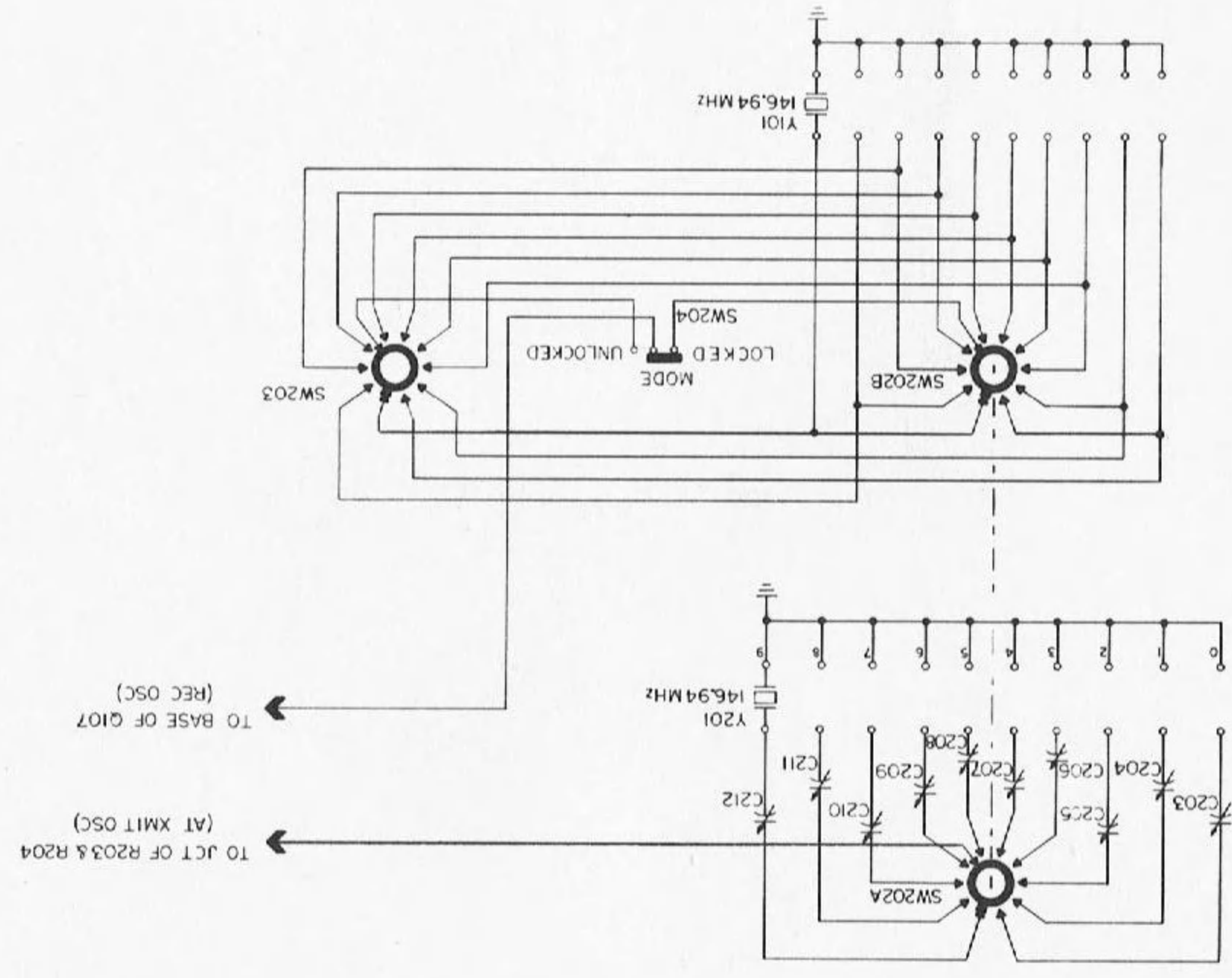
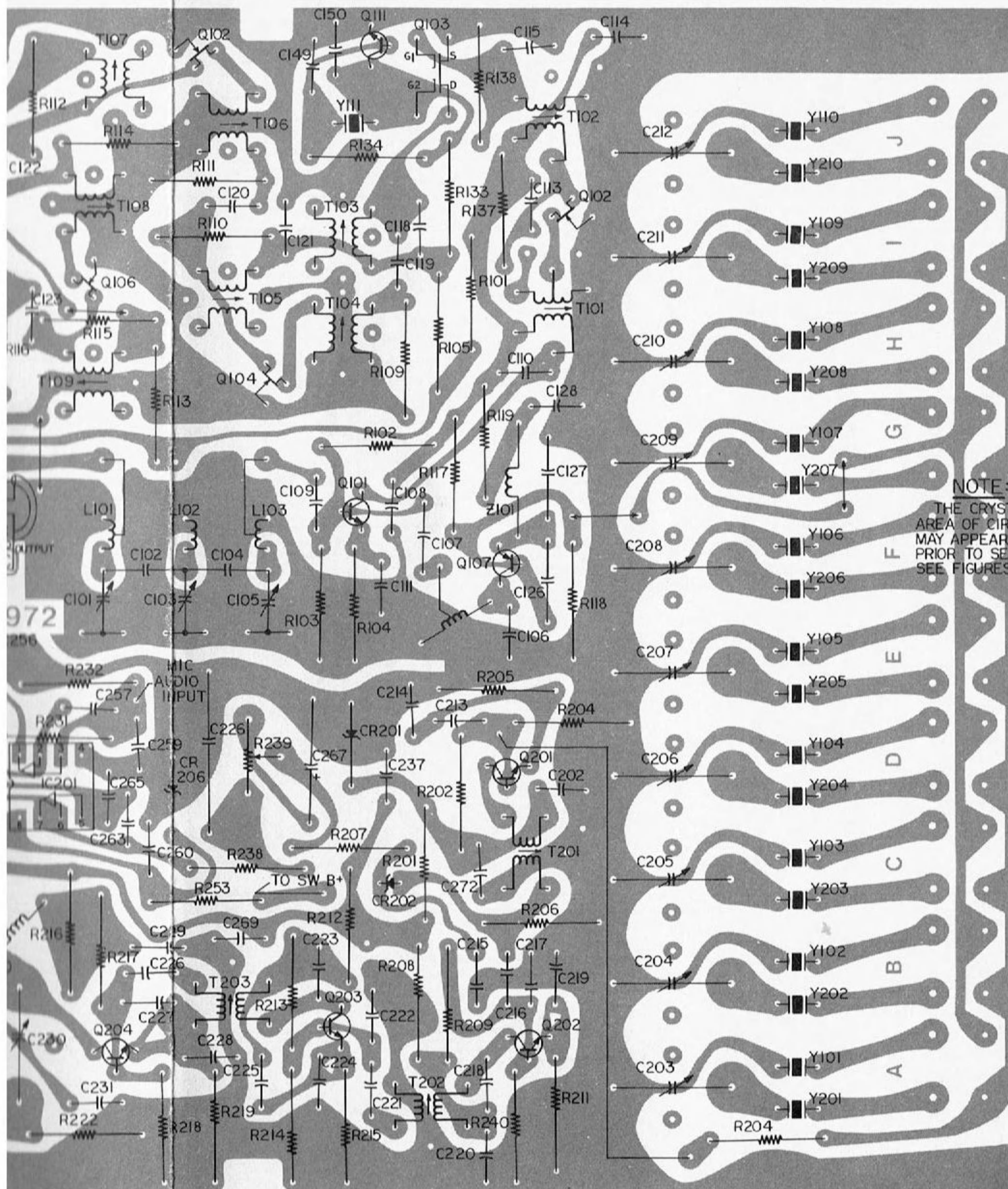

Figure 4
Series 170037K Board & Earlier



PARTS LIST



Ref. No.	Genave Part No.	Description
CAPACITORS		
C101	1570120	Trimmer, 1-6 pf
C102	1510004	NPO Gimmick, .27 pf
C103	1570120	Trimmer, 1-6 pf
C104	1510004	NPO Gimmick, .27 pf
C105	1570120	Trimmer, 1-6 pf
C106	1520005	NPO Disc, 6.8 pf, 10%
C107	1510011	NPO Gimmick, 1.0 pf, 10%
C108	1520051	Y5U, Disc, .01 mfd, 25V, 10%
C109		Unassigned
C110	1520176	N330, Disc, 82 pf, 10%
C111	1520048	Z5P, Disc, .001 mfd, 10%
C112	1520176	N330, Disc, 82 pf, 10%
C113	1520176	N330, Disc, 82 pf, 10%
C114	1520051	Y5U, Disc, .01 mfd, 25V, 10%
C115	1520176	N330, Disc, 82 pf, 10%
C116		Unassigned
C117	1520027	N750, Disc, 150 pf, 10%
C118	1520027	N750, Disc, 150 pf, 10%
C119	1520175	NPO, Disc, 7.5 pf, 5%
C120	1520175	NPO, Disc, 7.5 pf, 5%
C121	1520054	M25, Disc, .05 mfd, 25V, +80-20%
C122	1520175	NPO, Disc, 7.5 pf, 5%
C123	1520054	M25, Disc, .05 mfd, 25V, +80-20%
C125	1520054	M25, Disc, .05 mfd, 25V, +80-20%
C126	1520019	NPO, Disc, 68 pf, 10%
C127	1520016	NPO, Disc, 82 pf, 10%
C128	1520048	Z5P, Disc, .001 mfd, 10%
C129	1540014	Aluminum Electrolytic, 10 mfd, 16V
C130	1520047	Y5E, Disc, 820 pf, 10%
C131	1520022	N220, Disc, 100 pf, 10%
C132	1520022	N220, Disc, 100 pf, 10%
C133	1520051	Y5U, Disc, .01 mfd, 52V, 10%
C134	1520037	Y5E, Disc, 330 pf, 10%
C135	1520037	Y5E, Disc, 330 pf, 10%
C136	1520051	Y5U, Disc, .01 mfd, 25V, 10%
C137	1540014	Aluminum Electrolytic, 10 mfd, 16V
C138	1500024	Mylar, .022 mfd, 10%, 100V
C140	1520048	Z5P, Disc, .001 mfd, 10%
C139	1520055	Disc, .1 mfd, +80-20%, 12V
C141	1550004	Tant, 10 mfd, 25V, 10%
C142	1520055	Disc, .1 mfd, +80-20%, 12V
C143	1550005	Tant, 47 mfd, 10%, 15V
C144	1500004	Polyethyle, .0015 mfd, 10%, 250V
C145	1540038	Aluminum Electrolytic, 1000 mfd, 30V
C146	1540212	Aluminum Electrolytic, 200 mfd, 12V
C147	1520176	N330, Disc, 82 pf, 10%
C148	1520007	NPO, Disc, 10 pf, 10%
C149	1520047	Y5E, Disc, 820 pf, 10%
C150	1520176	N330, Disc, 82 pf, 10%
C202	1520054	M25, Disc, .05 mfd, +80-20%, 25V
C203	1560403	Trimmer, 40 pf
C204	1560403	Trimmer, 40 pf
C205	1560403	Trimmer, 40 pf
C206	1560403	Trimmer, 40 pf
C207	1560403	Trimmer, 40 pf
C208	1560403	Trimmer, 40 pf
C209	1560403	Trimmer, 40 pf
C210	1560403	Trimmer, 40 pf
C211	1560403	Trimmer, 40 pf
C212	1560403	Trimmer, 40 pf
C213		Selected value 22-220 pfd
C214		Selected value 22-220 pfd
C215	1520048	Z5P, Disc, .001 mfd, 10%
C216	1520176	N330, Disc, 82 pf, 10%
C217	1520015	N1500, Disc, 47 pf, 10%
C218	1520176	N330, Disc, 82 pf, 10%
C219	1520053	M25, Disc, .02 mfd, 10%
C220	1520051	Y5U, Disc, .01mfd, 10%, 25V
C221	1520027	N750, Disc, 150 pf, 10%
C222	1520027	N750, Disc, 150 pf, 10%
C223	1520010	NPO, Disc, 18 pf, 10%
C224	1520048	Z5P, Disc, .001 mfd, 10%
C225	1520027	N750, Disc, 150 pf, 10%
C226	1520012	NPO, Disc, 27 pf, 10%
C227	1520015	N1500, Disc, .001 mfd, 10%
C228	1520048	Z5P, Disc, .001 mfd, 10%

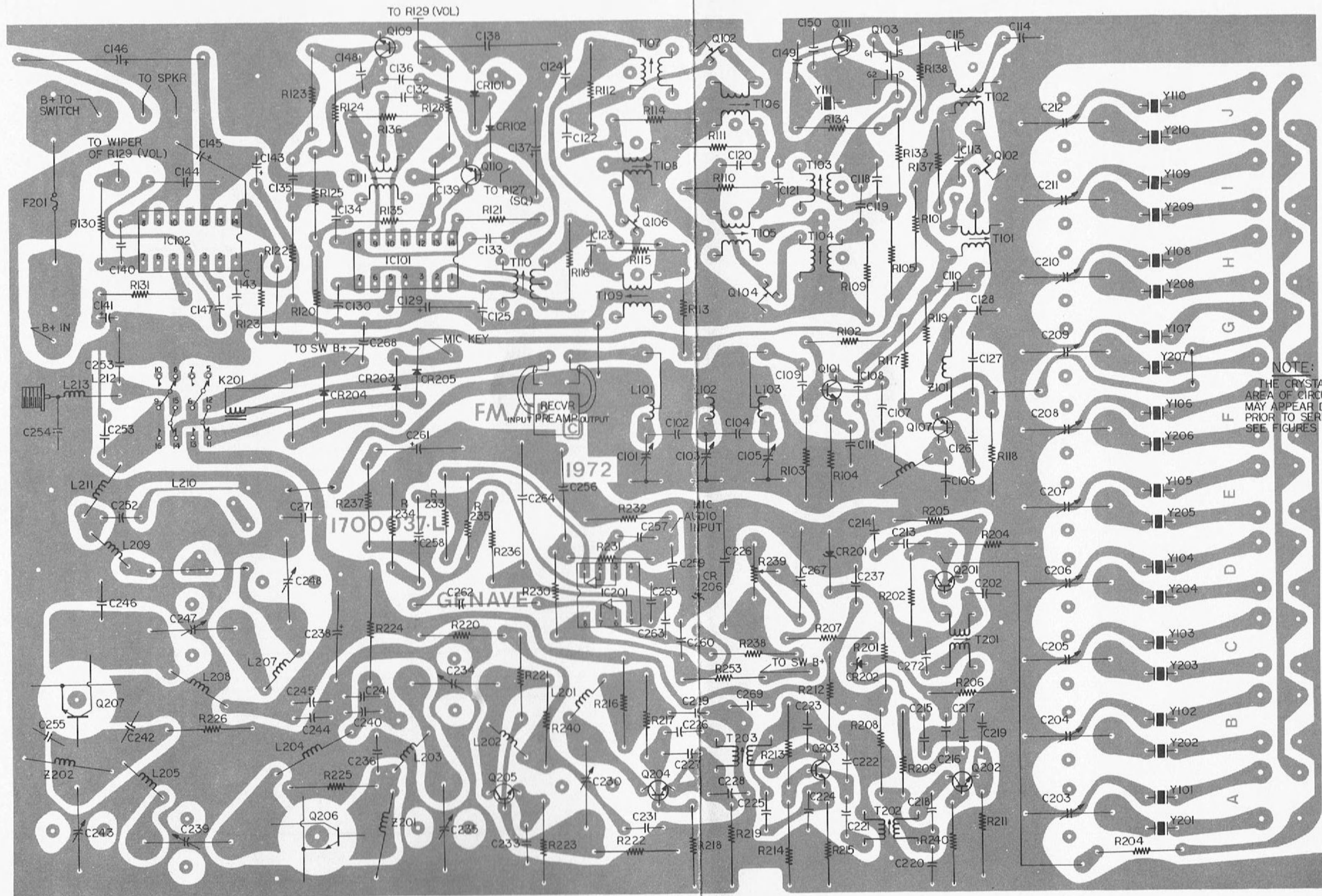

Parts/Truck Map
Figure 7

Ref. No.	Genave Part No.	Description
C229	1520054	M25, Disc, .05 mfd, +80 - 20%, 25V
C230	1560403	Trimmer, 40 pf
C231	1520048	Z5P, Disc, .001 mfd, 10%
C232		Unassigned
C233	1520048	Z5P, Disc, .001 mfd, 10%
C234	1560403	Trimmer, 40 pf
C235	1560403	Trimmer, 40 pf
C236	1520013	NPO, Disc, 33 pf, 10%
C237	1520042	Y5E, Disc, 470 pf, 10%
C238	1540002	Aluminum Electrolytic, 1 mfd, 40V
C239	1560406	Trimmer, 115 pf
C240	1520054	M25, Disc, .05 mfd, +80 - 20%, 25V
C241	1520048	Z5P, Disc, .001 mfd, 10%
C242	1520022	N220, Disc, 100 pf, 10%
C243	1560406	Trimmer, 115 pf
C244	1520054	M25, Disc, 0.5 mfd, +80 - 20%, 25V
C245	1520048	Z5P, Disc, .001 mfd, 10%
C246	1520014	NPO, Disc, 39 pf, 10%
C247	1560406	Trimmer, 115 pf
C248	1560406	Trimmer, 115 pf
C249		Unassigned
C250		Unassigned
C251		Unassigned
C252	1520011	NPO, Disc, 22 pf, 10%
C253	1520011	NPO, Disc, 22 pf, 10%
C254	1520011	NPO, Disc, 22 pf, 10%
C255	1520022	N220, Disc, 100 pf, 10%
C256	1540002	Aluminum Electrolytic, 1 mfd, 40V
C257	1520028	Y5E, Disc, 150 pf, 10%
C258	1540014	Aluminum Electrolytic, 10 mfd, 16V
C259	1520028	Y5E, Disc, 150 pf, 10%
C260	1520053	M25, Disc, .02 mfd, 10%, 25V
C261	1540014	Aluminum Electrolytic, 10 mfd, 16V
C262	1500018	Mylar, .01 mfd, 10%, 100V
C263	1520028	Y5E, Disc, 150 pf, 10%
C264	1500013	Mylar, 5 mfd, 10%, 100V
C265	1500028	Y5E, Disc, 150 pf, 10%
C266	1500018	Mylar, .01 mfd, 10%, 100V
C267	1540002	Aluminum Electrolytic, 1 mfd, 40V
C268	1520054	M25, Disc, .05 mfd, +80 - 20%, 25V
C269	1520054	M25, Disc, .05 mfd, +80 - 20%, 25V
C270		Unassigned
C271	1520034	Y5E, Disc, 220 pf, 10%
C272	1520022	N220, Disc, 100 pf, 10%
DIODE		
CR101	4810021	IN34A, Germanium
CR102	4810021	IN34A, Germanium
CR201	4810007	Zener, 6.8V, ±10%
CR202	4812109	Varicap, MV2109 SKV1638
CR203	4810013	Gen. Purpose, 100V @ 1 amp
CR204	4810013	Gen. Purpose, 100V @ 1 amp
CR205	4810013	Gen. Purpose, 100V, @ 1 amp
CR206	4810007	Zener, 6.8v, ±10%
LAMPS		
DS101	3900025	Clear—14.4V #53
DS201	3900025	Clear—14.4V #53
COILS		
L101	1800109	Coil, Input
L102	1800107	Coil, Center Pole Input Filter
L103	1800108	Coil, Output
L104	1800200	Coil, Osc.
L201	1800201	Coil, Transmitter
L202	1800201	Coil, Transmitter
L203	1800201	Coil, Transmitter
L204	1800202	Coil, Transmitter
L205	1800201	Coil, Transmitter
L206	1800204	Coil, Transmitter
L207	1800201	Coil, Transmitter
L208	1800204	Coil, Transmitter
L209	1800201	Coil, Transmitter
L210		Etched on Circuit Board
L211	1800203	Coil, Transmitter
L212		Etched on Circuit Board
L213	1800205	Coil, Transmitter
TRANSISTORS		
Q101	4800024	Silicon, NPN, Blue, MPS 3563
Q102	4805484	JFET, N. Channel, 2N5484

Ref. No.	Genave Part No.	Description
Q103	4800122	MOSFET, N. Channel, Dual Gate, MPF 122
Q104	4805458	JFTT, N. Channel, 2N5458
Q105	4805458	JFET, N. Channel, 2N5458
Q106	4805458	JFET, N. Channel, 2N5458
Q107	4800043	Silicon, NPN, MPS 5172
Q108		Unassigned
Q109	4800028	Silicon, NPN, Red, MPS 6513S
Q110	4800028	Silicon, NPN, Red, MPS 6513S
Q111	4800033	Silicon, NPN, MPS 5172
Q201	4800033	Silicon, NPN, MPS 5172
Q202	4800026	Silicon, NPN, White, MPS 3693S
Q203	4800026	Silicon, NPN, White, MPS3693S
Q204	4804427	Silicon, NPN, 2N4427
Q205	4804427	Silicon, NPN, 2N4427
Q206	4806080	Silicon, NPN, 2N6080
Q207	4806082	Silicon, NPN, 2N6082
RESISTORS		
R101	4700009	10 ohm, ±10%, 1/2 W
R102	4700037	10K ohm, ±10%, 1/2 W
R103	4700029	2.2K ohm, ±10%, 1/2 W
R104	4700025	1K ohm, ±10%, 1/2 W
R105	4700013	100 ohm, ±10%, 1/2 W
R106		Unassigned
R107		Unassigned
R108		Unassigned
R109	4700049	100K ohm, ±10%, 1/2 W
R110	4700049	100K ohm, ±10%, 1/2 W
R111	4700049	100K ohm, ±10%, 1/2 W
R112	4700049	100K ohm, ±10%, 1/2 W
R113	4700013	100 ohm, ±10%, 1/2 W
R114	4700049	100K ohm, ±10%, 1/2 W
R115	4700049	100K ohm, ±10%, 1/2 W
R116	4700049	100K ohm, ±10%, 1/2 W
R117	4700033	4.7K ohm, ±10%, 1/2 W
R118	4700041	22K ohm, ±10%, 1/2 W
R119	4700023	680 ohm, ±10%, 1/2 W
R120	4700011	68 ohm, ±10%, 1/2 W
R121	4700053	220K ohm, ±10%, 1/2 W
R122	4700043	33K ohm, ±10%, 1/2 W
R123	4700043	33K ohm, ±10%, 1/2 W
R124	4700057	470K ohm, ±10%, 1/2 W
R125		Unassigned
R126	4700031	3.3K ohm, ±10%, 1/2 W
R127	4760024	Variable, Linear Taper, 25K, ±20% (SQ)
R128		Unassigned
R129	4760025	Variable, Audio Taper, 25K, ±20%, (Vol)
R130	4700037	10K ohm, ±10%, 1/2 W
R131	4700015	150 ohm, ±10%, 1/2 W
R132	4700013	100 ohm, ±10%, 1/2 W
R133	4700033	4.7 ohm, ±10%, 1/2 W
R134	4700057	82K ohm, ±10%, 1/2 W
R135	4700045	47K ohm, ±10%, 1/2 W
R136	4700037	10K ohm, ±10%, 1/2 W
R137	4700041	22K, ±10%, 1/2 W
R138	4700041	22K, ±10%, 1/2 W
R201	4700015	150 ohm, ±10%, 1/2 W
R202	4700041	22K ohm, ±10%, 1/2 W
R203	4700041	22K ohm, ±10%, 1/2 W
R204	4700018	270 ohm, ±10%, 1/2 W
R205	4700023	680 ohm, ±10%, 1/2 W
R206	4700031	3.3K ohm, ±10%, 1/2 W
R207	4700037	10K ohm, ±10%, 1/2 W
R208	4700013	100 ohm, ±10%, 1/2 W
R209	4700047	68K ohm, ±10%, 1/2 W
R210	4700033	4.7K ohm, ±10%, 1/2 W
R211	4700016	180 ohm, ±10%, 1/2 W
R212	4700006	22 ohm, ±10%, 1/2 W
R213	4700031	3.3K ohm, ±10%, 1/2 W
R214	4700017	220 ohm, ±10%, 1/2 W
R215	4700006	22 ohm, ±10%, 1/2 W
R216	4700006	22 ohm, ±10%, 1/2 W
R217	4700033	4.7K ohm, ±10%, 1/2 W
R218	4700017	220 ohm, ±10%, 1/2 W
R219	4700006	22 ohm, ±10%, 1/2 W
R220	4700002	4.7 ohm, ±10%, 1/2 W
R221	4700029	2.2K ohm, ±10%, 1/2 W
R222	4700015	150 ohm, ±10%, 1/2 W

Ref. No.	Genave Part No.	Description
R223	4700003	10 ohm, $\pm 10\%$, 1/2 W
R224	4740009	68 ohm, Wire Wound, $\pm 10\%$, 2 W
R225	4700009	47 ohm, $\pm 70\%$, 1/2 W
R226	4700009	47 ohm, $\pm 10\%$, 1/2 W
R227		Unassigned
R228		Unassigned
R229		Unassigned
R230	4700045	47K ohm, $\pm 10\%$, 1/2 W
R231	4700052	180K ohm, $\pm 10\%$, 1/2 W
R232	4700053	220K ohm, $\pm 10\%$, 1/2 W
R233	4700045	47K ohm, $\pm 10\%$, 1/2 W
R234	4700015	150 ohm, $\pm 10\%$, 1/2 W
R235	4700037	10K ohm, $\pm 10\%$, 1/2 W
R236	4700035	6.8K ohm, $\pm 10\%$, 1/2 W
R237	4700043	33K ohm, $\pm 10\%$, 1/2 W
R238	4700034	5.6K ohm, $\pm 10\%$, 1/2 W
R239	4760021	50K ohm, Variable Minipot, 20%
R240	4700024	820 ohm, 10%, 1/2 W
R253	4700015	150 ohm, $\pm 10\%$, 1/2 W
IC's		
TC101	3136666	Silicon, TISN76666N
TC102	3136001	Silicon, Audio Output, 5N76001N
TC201	3130012	Op. Amp., N5558V
TRANSFORMERS		
T101	5600080	Input, 1st IF
T102	5600080	Input, 1st IF
T103	5600076	455 kHz
T104	5600012	455 kHz IF, White Core
T105	5600012	455 kHz IF, White Core
T106	5600012	455 kHz IF, White Core
T107	5600012	455 kHz IF, White Core
T108	5600012	455 kHz IF, White Core
T109	5600012	455 kHz IF, White Core
T110	5600012	455 kHz IF, White Core
T111	5600012	455 kHz IF, White Core
T201	5600081	Osc
T202	5600082	Tripler
T203	5600083	1st Double
CRYSTALS		
Y111	2300251	12.645 MHz
Y201	2300423	146.940 MHz, Xmit
Y202	2300422	146.940 MHz, RCV
CHOKES		
Z101	1800035	1 microhenry, 200 series
Z201	1800063	Ferrox Cube Core
Z202	1800063	Ferrox Cube Core
MISCELLANEOUS		
K201	4500007	Relay, 4PDT, R10-E2-X4-V185 PB
SW201	5100051	Switch, Slide, Off/Lo/Hi
SW202	5100073	Switch, Rotary, XMIT/XCVE
SW203	5100072	Switch, Rotary, RCVE
SW204	5100039	Switch, Mode Selection
	2502311	Panel Front
	2508061	Panel Trim
	2502331	Knob, Vol & Sq.
	2508211	Knob, Freq. Selectors
	2508072	Bracket Sub-Panel
	2502281	Bracket Transistor
	2502292	Bracket Mtg. (Handle)
	2502321	Cover
	1325069	Microphone (ceramic)
	1340408	Speaker, 1.5 W, 8 ohm

Figure 8 DC VOLTAGE MEASUREMENTS

All voltages shown in this table were measured with a VTVM from chassis ground. The DC input to the radio should be set to 13.75 VDC. The squelch control should be in the full off position and the volume control in the minimum position. No signal should be applied. The receiver A+ line should measure 13.0 VDC. A variation of $\pm 20\%$ of the measured voltages from those listed may be considered normal.

Ref. No.	E	B	C	or	D	S	G	G ²						
Q101	1.8	2.4	12.4											
Q101														
Q102					12.4	0	0							
Q103					11.0	0	0	5.8						
Q104					11.0	0	0							
Q105					11.6	0	0							
Q106					11.6	0	0							
Q107	6.8	6.2	0											
Q109	0	0.6	2.8											
Q110	0	0.47	5.8											
Q111	0	0.42	5.8											
Q201 (Recv)	6.5	7.2	6.8											
Q201 (Xmit)	2.5	3.2	6.8											
Pin	1	2	3	4	5	6	7	8	9	10	11	12	13	14
IC101	2.0	2.0	0	0	11.5	—	5.6	4.8	4.1	4.1	—	5.4	5.8	1.6
IC102	12.8	—	7.7	0.8	0.6	—	0	0	—	0	—	6.5	—	12.9

RECEIVER SENSITIVITY & GAIN MEASUREMENTS

Frequency	Input Point	Measurement Point	Measured Value
146.940 MHz	Ant. Conn.	Across Speaker	-109 dbm or better for 20 db quieting
13.1 MHz	Tap L103	Sec. T110	500 uv or less for 0.3 V P-P (Scope)
13.1 MHz	Pin 3 T102	Pri. T104	45 mv for 0.3 V P-P (Scope)
13.1 MHz	Pin 3 T102	Source Q104	70 mv for 0.3 V P-P (Scope)
13.1 MHz	Pin 3 T102	Drain Q104	11 mv for 0.3 V P-P (Scope)
13.1 MHz	Pin 3 T102	Pri. T106	13 mv for 0.3 V P-P (Scope)
13.1 MHz	Pin 3 T102	Source Q105	23 mv for 0.3 V P-P (Scope)
13.1 MHz	Pin 3 T102	Drain Q105	3.4 mv for 0.3 V P-P (Scope)
13.1 MHz	Pin 3 T102	Pri. T108	5.5 mv for 0.3 V P-P (Scope)
13.1 MHz	Pin 3 T102	Source Q106	10 mv for 0.3 V P-P (Scope)
13.1 MHz	Pin 3 T102	Drain Q106	1.5 mv for 0.3 V P-P (Scope)
13.1 MHz	Pin 3 T102	Pri. T110	1.5 mv for 0.3 V P-P (Scope)
13.1 MHz	Pin 3 T102	Sec. T110	3 mv for 0.3 V P-P (Scope)
146.940 MHz	Ant. Conn.	Across Speaker	2 uv or better for 1 watt output, 400 to 3000 Hz.