

• Recent Equipment —

The Gonset Sidewinder

2-Meter Transceiver

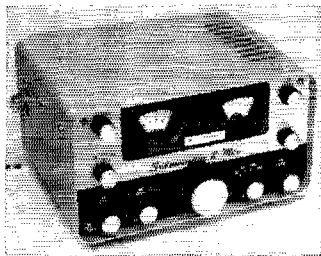

THE transceiver-oriented ham from the h.f. bands will feel quite at home with the Gonset 2-meter Sidewinder. Only the readings in megacycles will be greatly different from what he has already learned to live with in sideband work on lower bands. But the v.h.f. man, steeped in band-tuning traditions of the 2-meter band, will likely find the Sidewinder transceiver approach about as foreign as anything can be — at least for a while.

The Sidewinder is "sideband" all the way. In technical concept or in the operating habits it induces, this is a clean break with v.h.f. practice. It will be interesting to see how it fares on the commercial market, on this account. Here we have the first true transceiver, in the h.f. sideband sense, that has become available to the 2-meter fraternity. One tuning system and one crystal-lattice filter work on both transmitting and receiving. The operator must become accustomed to transmitting on the receiving frequency, regardless of mode, with an equipment design tailored to the needs of the sideband operator.

Like most sideband transceivers, the Sidewinder works beautifully on c.w. (praises be!) but a.m. operation, while satisfactory, is defini-

tely a secondary matter. Reception on a.m. is very good, and so is transmitter quality — if (and it is a large if) the operator will follow instructions and turn the output down to the appropriate level. From what we've heard of other Sidewinders on the air, there is a certain unwillingness on the part of users to accept this inevitable limitation on a.m. operation with sideband gear. The 3-ke. selectivity of the receiver will come as something of a shock to the 2-meter man accustomed to the bandwidth of a.m. transceivers of this same maker's earlier production. You don't drift and stay in *this* receiver's passband!

Another respect in which the Sidewinder is new to most v.h.f. men is its all-solid-state receiver and sideband generator circuitry. There are only three vacuum tubes in this outfit, all in the r.f. portion of the transmitter. All other circuits: receiver, audio stages and all sideband-generating stages, use transistors and diodes. A pleasant by-product of this is extremely low receiving drain. If you leave the transmitter heaters off (and there's a switch to permit this) you could receive for days on a car battery. Even on TRANSMIT the power drain at 12 volts is 8 amperes, maximum. This is for 20 watts input on c.w. or p.e.p. sideband, or 6 watts a.m.

How It Works

With the many overlapping functions of stages in a transceiver, explaining operation with the aid of a block diagram almost reaches the point of diminishing returns, but we'll have a go at it with Fig. 1. This is similar to the diagram in the Sidewinder instruction manual, but with minor changes for purposes of this discussion. First, don't let the diagram fool you — the Sidewinder is not really this simple. Only 22 circles appear in Fig. 1, but this little box has 3 tubes, 21 transistors and 8 diodes in the r.f. package, 9 diodes in the a.c. supply, and 6 in the d.c. supply — and many of these do double duty.

Functions are indicated in the diagrams; T denotes use on transmitting only, R is for receiving only, and TR for both. Here, briefly, is what happens along the way. At the top of Fig. 1 is a crystal oscillator, Q_{18} , with v.h.f. crystals at 64.75, 65.25, 65.75 or 66.25 Mc., depending on the position of the FREQUENCY SELECTOR switch on the front panel. A buffer, Q_{19} , follows, trans-

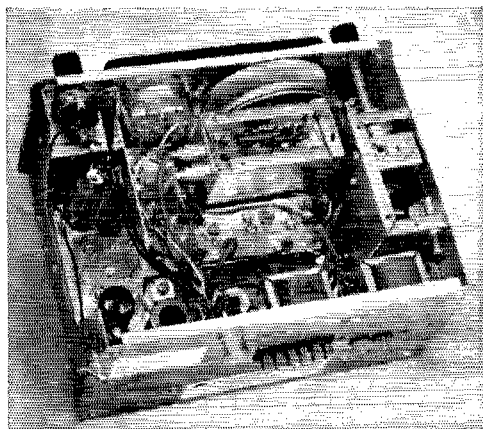

Top view of the Sidewinder interior. The transmitter r.f. tubes at the left are the only vacuum tubes in the outfit. The assembly at the far right, with cover plate removed, is the balanced modulator. Near the upper center, also with cover removed, is the v.f.o. assembly.

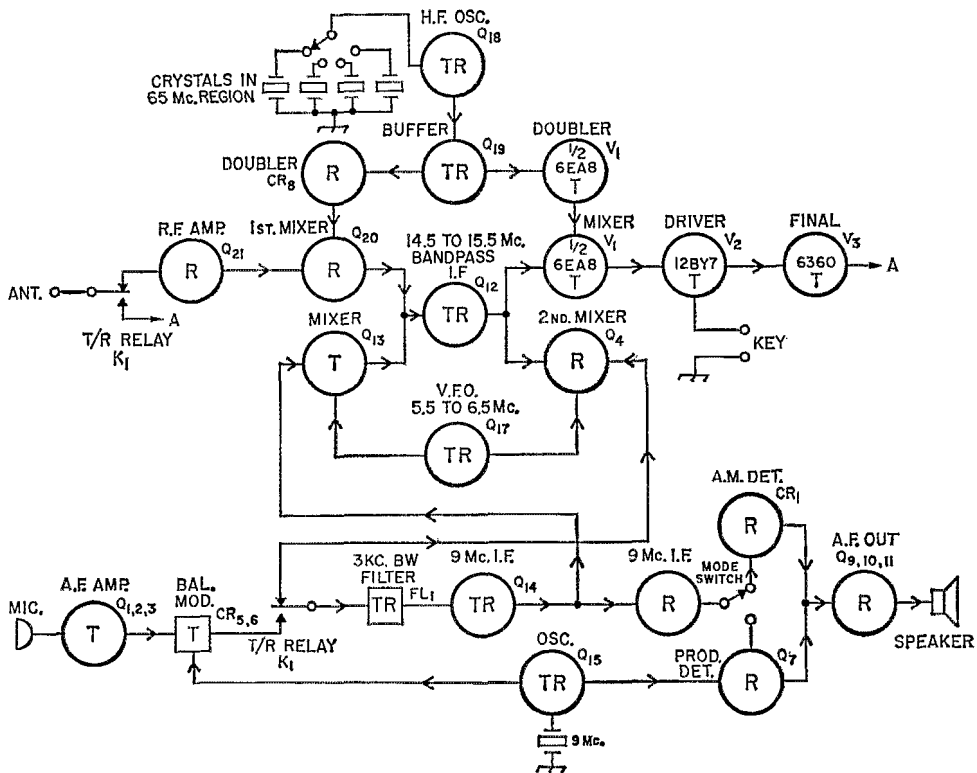

Fig. 1—Simplified block diagram of the Sidewinder 2-Meter Transceiver.

mitting or receiving. Next, we have doublers; a diode, CR_8 , in the receiver, and the triode portion of a 6EA8, V_1 , in the transmitter. Output frequency is 129.5, 130.5, 131.5 or 132.5 Mc., either way.

At the upper left we see a receiving r.f. amplifier, Q_{21} , and the first mixer, Q_{20} , where the above frequencies beat with incoming signals, converting them to an intermediate frequency in the 15-Mc. region, after which they are built up by the band-pass i.f. amplifier, Q_{12} . Each of the crystals with Q_{18} thus accounts for a 1-megacycle segment of the band, starting at 144, 145, 146 or 147 Mc., in the order given above, the i.f. being 14.5 to 15.5 Mc.

In receiving there follows a second mixer, Q_4 . In addition to the i.f. signal, this gets energy from a tunable oscillator, Q_{17} , working at 5.5 to 6.5 Mc., and driven by the main tuning dial. Result: output on 9 Mc., which is fed to the crystal-lattice filter, FL_1 , and then through Q_{14} and Q_5 and Q_6 , all 9-Mc. i.f. amplifiers. FL_1 and Q_{14} will be encountered again later when we follow the transmitting circuitry through the maze. Finally, the signal is fed to a diode a.m. detector, CR_1 , or a transistor product detector, Q_7 , to an audio driver, Q_9 , and push-pull audio amplifier, Q_{10-11} , to the phones or speaker.

Now let's back-track and follow the transmitting lineup. Generation of the basic carrier signal begins with the 9-Mc. crystal oscillator,

Q_{15} , at the bottom of Fig. 1. This also serves as a beat oscillator in receiving, its output being fed to the product detector or to the balanced modulator. We're concerned with the latter now. With the mode switch in the AM or USB positions the audio from the speech amplifier, Q_{1-2-3} , is combined with the 9-Mc. signal in the balanced modulator, CR_{5-6} . In the CW position, the audio is disconnected by the mode switch. In the USB position the balanced modulator cancels out the carrier, leaving audio sidebands. These pass on to the filter, where the high selectivity suppresses the unwanted lower sideband. The amplifier output of Q_{14} is then a 9-Mc. s.s.b. (upper sideband) or c.w. signal.

In the AM position of the mode switch the modulator is slightly unbalanced by a front-panel control, so that a carrier and a normal pair of sidebands are fed into the filter. The filter eliminates the lower sideband, and partially attenuates the carrier, leaving reduced carrier and upper sideband to be fed into Q_{14} . The original carrier level is adjusted manually, so that the signal is the equivalent of a 100-percent-modulated a.m. signal. It will sound just like one to the casual operator at the receiving end, but it will occupy a narrower band.

Now the process is about the reverse of that in receiving. The output of Q_{14} is whatever kind of signal we intend to radiate, but it is on 9 Mc., and at very low level. It is fed to another mixer, Q_{13} , along with the signal from our old friend the

5.5 to 6.5-Mc. dial-tuned v.f.o., Q_{17} . Result: output on 14.5 to 15.5 Mc., which then goes through the band-pass amplifier, Q_{12} , just as did the i.f. output from the receiving mixer. Now we get back almost to where we started. Remember, we had energy at 129.5 to 132.5 Mc. applied to the pentode section of V_1 , the first vacuum tube in the transmitting lineup, a mixer. Adding 14.5 to 15.5 to these frequencies, we get output at 144-plus, 145-plus, 146-plus or 147-plus, depending on the position of the sector switch and the setting of the v.f.o.

From here on we're on more familiar ground, with a 12BY7, V_2 , and a final amplifier 6360, V_3 , building up whatever type of signal we selected with the mode switch. This will have seemed like old stuff to the experienced sidebander, but this 2-meter job is going to catch a lot of newcomers to the s.s.b. mode, who may have paid very little attention in the past to the way in which a sideband signal is produced and processed in the

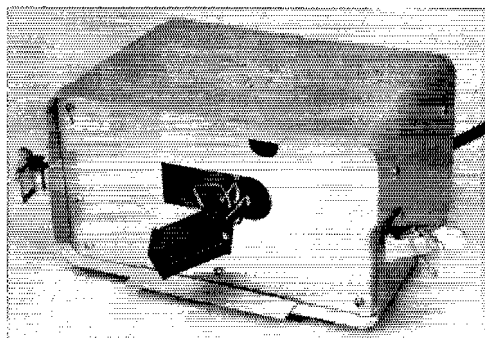

The Sidewinder power supply package clamps onto the back of the r.f. unit. Two supplies are available, one for a.c. and the other for 12-volt d.c. service.

only the r.f. package, which is just about the front half. Snapping onto the back of this is a power supply, which can be for 115 volts a.c., or 12 volts d.c. Supplies are sold separately, which helps to hold the price down a little for the man who is interested in only one or the other. The power unit is shown separately in a later photograph.

Being almost entirely solid-state, the Sidewinder is a very compact and light unit, even with supply attached. The main r.f. and audio assembly is a printed circuit job, visible as the dark portion of the bottom view. The transmitter r.f. section is at the left side of this same picture.

Front-panel control for the main tuning, at the lower center, is a smooth-working two-speed vernier drive. Its scale is numbered .1 .2 .3 and so on, with each radial line between these numbers representing 25 kc. Tuning rate on the outer portion of the knob is fast enough to get you across the 1-megacycle range in good time, and the slow-speed inner knob handles s.s.b. signals very smoothly. You have never tuned in sideband any more easily.

Flanking the main dial are the receiver r.f. gain, left, and the sector switch, right; the latter for choosing the 1-megacycle range you want to listen to or transmit on. The r.f. gain control has a pull-out switch for turning on the transmitter heaters and dial lights. With these off (knob in) you receive with very low drain, and instantaneously when the audio gain control switch (left corner) is turned on.

Above left are the mode switch and carrier-balance controls. The latter is a 10-turn potentiometer, for very smooth vernier action. Lower right is the amplifier tuning control, and above it the antenna loading control for transmitting. Top right: microphone gain control, with pull-out switch for send-receive. The microphone jack, on the left side of the case, takes a push-to-talk microphone on a PL-68 plug. Just below it is the c.w. keying jack. Grid-block keying is applied to the 12BY7 driver, making the c.w. signal of the Sidewinder a far cry from the thumping of unfiltered cathode keying that we hear so much of in v.h.f. c.w. work.

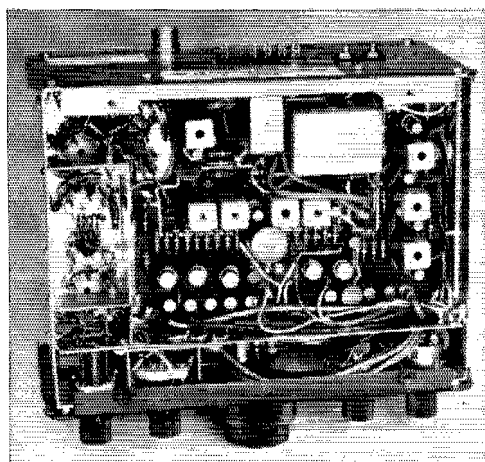

Bottom of the Sidewinder, showing the printed-circuit assembly and most of the transistors. The final amplifier plate circuit is visible at the left.

crystal-filter type of transmitter. It sounds complicated, and in a way it is, merely because we do a lot of things along the way, but each step in itself is a basically simple process.

The end product is a sideband signal that can stand comparison with any you'd find on lower bands, because the quality and stability are developed and maintained in exactly the same way. This is a v.h.f. rig in which the phone signal, regardless of mode, is no more than 3 kc. wide, and the c.w. signal is a beautiful T9, and rock steady, despite its being v.f.o.-controlled. Sideband tunes in on 2 just as easily as it would on 75, and c.w. reception is a real joy as well.

Construction

If the Sidewinder package looks smaller in our first picture than other shots of the equipment you've seen, it's because we photographed

The Instruction Manual has an incomprehensible paragraph on loaded mobile antennas that must have slipped in from another book, but otherwise it is detailed and well done.

Performance

Transmitter input is about 20 watts c.w., and 20 watts p.e.p. on upper sideband (upper only). Input on a.m. is rated at 6 watts, maximum. Like all linear amplifier operation, this is a critical business, but it can be made to sound very fine indeed if adjusted with care.

Stability is adequate for dependable s.s.b. work, after 15-minute warmup, and drift, even from a cold start, is not observable on other than s.s.b. — *W1HDQ*

QST

Gonset Sidewinder 2-Meter Transceiver, Model 900A

Height: 5½ inches.

Width: 9½ inches.

Depth: 7¾ inches, without power supply, which is 6 inches deep.

Weight: 10 pounds, 10 ounces; power supply 13 pounds, 8 ounces.

Power Requirements: 115 volts a.c., 100 watts; 12.6 volts d.c., 8 amps. max. A.c. and d.c. supplies are separate units.

Price Class: \$100. A.c. power supply, \$68, d.c. power supply, \$80.

Manufacturer: Gonset, Inc., 1515 S. Manchester Ave., Anaheim, California.

NEW BOOKS

Space Communications, by Stanley Leinwolf. Published by John F. Rider Publisher, Inc., Div. of Hayden Publishing Company, Inc., 850 Third Ave., New York 22, N. Y. 6 by 9 inches, 166 pages, including index, illustrated, paper cover. Price, \$3.95.

The book is a valuable treatment of the subject to the radio amateur interested in participating in such a program or solely interested in reading about the amazing discoveries in space communications during the past seven years. In understandable language even to the nontechnical reader, it describes as well what we are to expect in the immediate future in this rapidly advancing science.

Opening chapters cover the present state of world communications (ionosphere, seasonal and geographical variations, sunspots — of extreme importance in this field), principles of space communications (noise sources, frequency dependence on antenna systems, tracking). These are followed by chapters on passive space communications systems (transatlantic moon relay, moonbounce, Operation Smokepuff, amateur participation, Echo), active communications satellites (Project SCORE, Telstar, Telemetry, Relay 1, Syncom), special purpose satellites (Pioneer, Ranger, orbiting observatories, Tiro, Nimbus), Flight of Mariner II (significant to the hobbyist in that the electronic equipment developed to monitor its signal will soon be available commercially). From there on, are chapters especially interesting to the radio amateur — amateur in space, followed by descriptions of the Oscar satellites. There is a brief history of the radio amateur from the days of Marconi to the present time. — *W1ZIM*

Semiconductor Network Analysis and Design, by Vasil Uzunoglu. Published by McGraw-Hill Book Company, 330 West 42nd St., New York, N. Y. 10036. 372 pages, 6¼ inches, cloth cover. McGraw-Hill Series in Solid-State Engineering. Price, \$12.50.

Here is an up-to-date reference text for the design engineer that covers all the advances in the semi-conductor field. Distributed parameters in semiconductors, pole-zero amplifier design methods, root-locus design of feedback amplifiers, negative resistance devices, active *R.C.* filters, and return ratio and difference in transistor networks are covered. Each circuit is explained as an active device and its associated passive networks. The mathematical analysis of each circuit is presented, and examples given for clear understanding. Other chapters cover transistor physics, small-signal parameters and equivalent circuits, matrix analysis of transistors, high-frequency behavior, stability considerations, broadbanding techniques, and logic and switching circuits. As one can see, this book is only for the

very advanced radio amateur who wishes to keep pace with transistor technology.

Transistor Specifications and Substitution Handbook, by the Editorial Staff of TechPress Publications, P.O. Box 32, Brownsburg, Indiana. 6 × 9 inches, paper cover. Price, \$1.95.

The sheer numbers of transistors available today, each with its associated set of specifications, has made the job of substitution rather a difficult one. No one could plow through the mountain of specs to find one that is like the transistor being replaced. Many books on transistor substitution have been printed, but the question arises as to what constitutes an acceptable substitute. This book has chosen each listed substitution so that the transistor will be at least equal to the original, and up to 30 per cent higher specifications. This job of sorting and matching all the transistor types was done on a computer. The transistor type is given with a notation if it is an obsolete type, the manufacturer, the transistor's ratings, base type, and the substitute types with a notation if the substitute is obsolete. The type is large enough to be easily read at a normal distance. In the rear of the book is a complete list of all the base diagrams referenced in the transistor listings. Several pages are devoted to explaining the transistor ratings, and how the ratings can be used to help in the selection of a substitute.

Radio Operating Questions & Answers, 13th edition, by Jules L. Hornung and Alexander A. McKenzie. Published by McGraw-Hill Book Company, 330 West 42nd St., New York, N. Y. 10036. 598 pages, including index, 5½ by 8¼ inches, cloth cover. Price, \$825.

The thirteenth edition of this well-known book is for those interested in the FCC commercial licenses. This book covers the examination requirements for all classes of radiotelephone and radio telegraph licenses, plus the restricted radiotelephone permit, the aircraft operators endorsement, and the ship radar endorsement. The text is broken into the same elements as the FCC exams, and is in a question and answer format. The changes from the twelfth edition include a complete rewriting of Element 1, new questions added to Element 2, and the new Broadcast Operation Element 9. The questions are grouped into sections according to topics, such as power supplies, theory, receivers, etc. This information is for self-testing and reference, and not to teach the complete subject of electronics. The appendix gives additional information to complete the book, such as world time signals, color codes, artificial respiration, and the current radio operating codes.

— *W1KLL*