

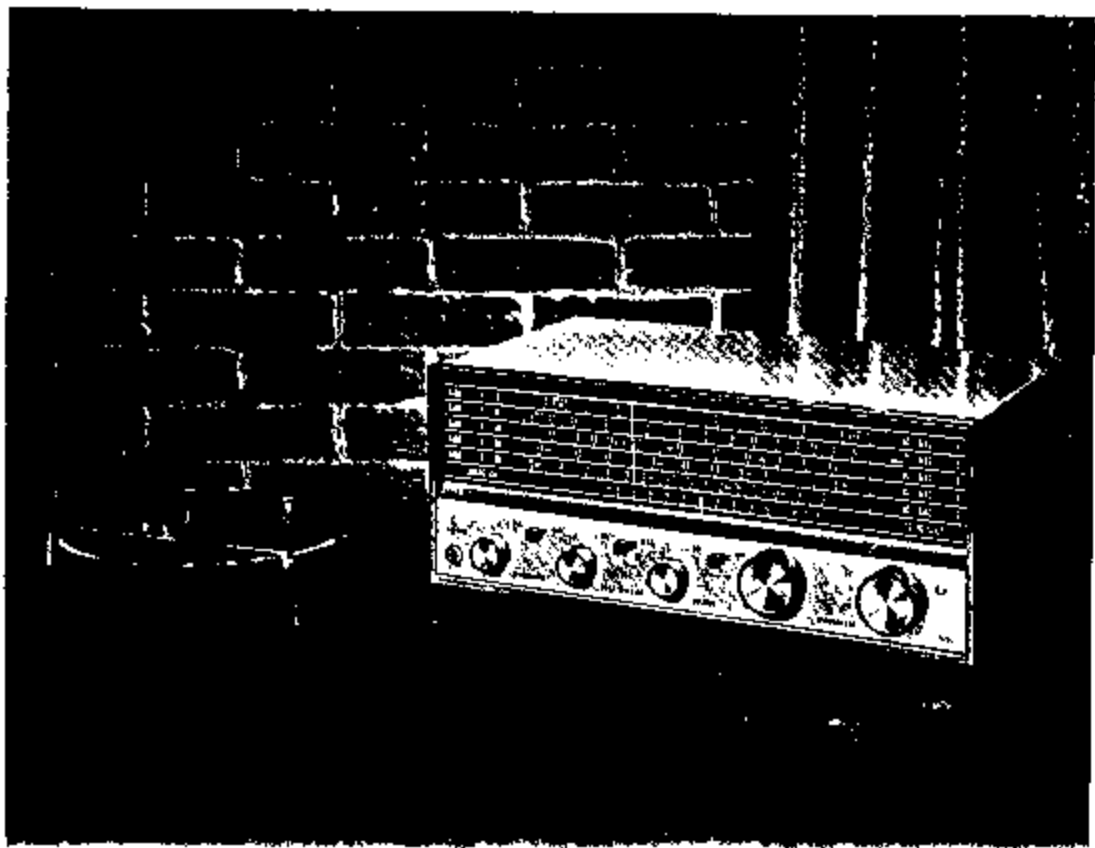

*hallicrafters*

OWNERS GUIDE

MODEL S-118 MARK II  
FIVE BAND  
COMMUNICATIONS RECEIVER



GET SET FOR EXCITING ADVENTURES  
 OUT OF THIN AIR .  
 AS YOU TUNE IN THE WORLD  
 ON YOUR *hallicrafters* COMMUNICATIONS RECEIVER

From the grim wilderness of a remote village in the central Congo the voice of a missionary cries out, "Please hurry . we need help . there's no time



A hair's breadth away another voice--almost monotonous in its calm business-like, professional manner, booms in--"Charlie base this is Air Force Zebra Two Nine Bravo target bearing Zero-Three-Zero angels fifty-two Roger, I have him in sight "

From a bomber over the Aleutians to the darkest reaches of Africa from a satellite in outer space to America's nuclear submarines voices like these, the voices of modern pioneers of adventure, are yours to command with a twist of the dial, in your own living room



This is the amazing world of Short Wave Listening--an exciting world, a serious world, a world of infinite variety

Only by short wave radio can you become a witness to history as it occurs

And only through short wave can you hear, in a single day a Wagnerian opera from Heidelberg . . . a news broadcast from behind the Iron curtain and an airport control tower bringing in a crippled plane :



Every moment of every day and night, Short Wave brings into your home an absorbing new interest--a fascinating way to keep up with international affairs, to be informed and stay informed.

This book was prepared to give you a quick and thorough Guided Tour of Short Wave, and to help you enjoy more fully this wonderfully informative pastime  
 Good listening \*

Where You Will Find It

How SHORT WAVE LONG WAVE Broadcasting works	Page 2
Why SHORT WAVE is used for long distance transmission	Page 2
What you will hear . . . . .	Page 3
Radio terms . . . . .	Page 4
Morse Code (CW) . . . . .	Page 4
Setting up your Communications Receiver	Page 5
Description of features and controls . . . . .	Page 6, 7
How to operate your receiver . . . . .	Flap & Page 8
Service and operating questions . . . . .	Page 8
Outside antenna . . . . .	Page 9
Megacycles to meters conversion . . . . .	Page 9
Greenwich Mean Time (G.M.T.) and conversion to local time	Page 10
Station Log . . . . .	Page 11 & 12
Service Data . . . . .	Inside Back Cover

## HOW SHORT WAVE ... LONG WAVE BROADCASTING WORKS

Understanding the mechanics of short-wave radio will help you receive the most enjoyment and the greatest thrills for the hours you spend at the dials.

You may often have heard the term *wave length* applied to the radio signals transmitted by a broadcasting station. Radio signals travel in waves; the wave length is the distance between the crests of the waves.

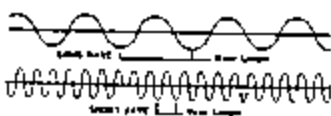

The total number of complete waves (or cycles) that a station can send out per second is referred to as *frequency*. The broadcasting frequency, therefore, is determined by the wave length on which a particular station is transmitting. The shorter the wave length, the higher the frequency.

Every radio station in the world is licensed to broadcast on certain assigned frequencies or bands of frequencies.

The standard broadcasting stations such as those in your home town are assigned to lower frequencies, or longer wave lengths. The high-frequency bands are reserved for other types of transmitting stations throughout the world known as Short-Wave Stations.

### Why Short Wave Is Used For Long Distance Transmission

The chief characteristic of short waves is their amazing ability to span enormous distances.

The illustration shows the manner in which all radio signals travel in waves as they leave the transmitter antenna. Some of the signal hugs the ground while the rest travels upward and outward away from the earth.



You are able to hear short-wave radio signals over great distances because they are refracted back to earth from layers of rarified gases high in the ionosphere. Short-wave signals enter the ionosphere and are refracted (bent) by the layer's electrical particles.

The physical action is similar to skipping a stone on smooth water. If the stone is of the correct size and shape and is thrown with enough power at the right angle, it will skip over the water's surface. The short-wave signal finds the ionosphere just as particular

Similarly, the short-wave signal must be of the right size (frequency)

It must strike or enter the ionosphere at precisely the correct angle and it must have sufficient power.

It may take several skips (just like a stone) for the signal to travel from the distant transmitter to your receiver. With each consecutive bounce, the signal becomes weaker until it is too weak to continue its process of refracting from the ionosphere back to earth (where it is heard), back off the earth into the ionosphere, and then again back to earth.

At different periods of the year, short-wave reception improves above the normal value between your receiving site and various areas of the world. As an example, the Spring months bring the strongest signals from Australia and the South Pacific. In the fall months, signals from Europe and the Far East dominate the dials. Also as daylight comes into darkness each day between your receiving location and the transmitting station, so does the nature of the reception. Day-to-day variations are also present.

## What You May Hear On The Short Wave Bands

The Short Wave Bands are your passport to a world of exciting adventures

**AMATEUR RADIO** Amateur (ham) radio stations are operated by private citizens in more than 250 countries around the globe

Amateurs talk to other amateur operators for personal pleasure or experimentation. No business or commercial transactions are permitted over stations operating in this service. Hams are allowed to operate on any frequency within assigned bands. The most commonly used are the 80-meter band; and the 40-, 20-, 15-, and 10-meter bands. (See page 9 for an explanation of the relationship between megacycles and meters.)

**SHIP-TO-SHORE, MOBILE RADIO-TELEPHONE** Essentially a telephone without wires. Operated by telephone companies and businesses who lease transmitters and receivers to individuals.

Listen at approximately 2.1 MC

**AERONAUTICAL-AIRPLANES-AIRPORTS** - Weather information, flight conditions, re-routing of planes in time of bad weather. General communications between planes and stations on the ground

You will find signals in this service at approximately 2.6, 2.9 to 3.0, 4.1, and at approximately 7.6 MC

**MILITARY** Air Force, Army, Navy, Marine, and Coast Guard communications may be heard between ground stations and planes or vehicles 24 hours a day. These signals may be heard throughout the short-wave frequency range

**MARITIME MOBILE.** In addition to military naval forces, commercial vessels, fishing fleets, and pleasure craft regularly communicate routine and emergency messages on short wave. These may be heard in the ranges from 2 to 3 MC, 4 to 4.4 MC, 6.2 to 6.5 MC, and 8.1 to 8.6 MC

**CITIZENS BAND** Low-cost, two-way radio now available to private citizens on the 11-meter band. More than 1,000,000 U.S. citizens are expected to be operating citizen-band transmitters. No operator's license is required. You will find the 11-meter band at approximately 27 MC

**INTERNATIONAL SHORT-WAVE BROADCASTING** Of all of the services you'll meet on short wave international broadcasting offers the most varied entertainment. Many governments operate powerful short-wave transmitters (e.g., the U.S. Government's Voice of America) to keep the world informed of activities within their countries. Many countries also license commercial short-wave stations, and in fact, many regions of the world conduct much of their daily broadcasting on short wave, instead of the standard broadcast band. Major frequency assignments are indicated by the dots located in the upper portion of the bands. For specific stations and frequencies consult your Station Log

**STANDARD TIME SIGNALS** WWV United States National Bureau of Standards broadcasts the correct time with voice as well as code identification. The identification occurs during the last two minutes of each 5 minute period (i.e., 03 to 05, 08 to 10, 13 to 15, etc). Other checks such as radio frequency, audio frequency, and forecast of conditions which will affect radio reception are broadcast. WWV will be found at 2.5, 5.0, 10.0, 15.0, 20.0, and 25.0 MC

# ADDITIONAL INFORMATION WHICH WILL ENRICH YOUR SHORT WAVE LISTENING PLEASURE

## Glossary of Familiar Short Wave Terms

AF Gain Control -- same as volume control      AM -- Amplitude Modulation -- the transmitting frequency amplitude is varied at an audio rate . . . ANL -- Automatic Noise Limiter -- reduces impulse noises (ignition, static, crashes, etc.) . . . ANT -- Antenna . . . AVC -- Automatic Volume Control -- controls radio frequency gain automatically -- (i.e., reduces gain on strong signals) . . . BFO -- Beat Frequency Oscillator -- provides a special beating signal so that CW (code) signals can be heard . . . CQ -- a general call used by radio amateurs to establish contact. Caller will talk to anyone who answers. Can also be used specifically (CQDX, when calling only DX stations, or CQ Chicago, when calling stations only in Chicago) . . . CW -- Continuous Wave -- unmodulated signal wherein intelligence is transmitted by interrupting signal to produce dots and dashes (code) . . . DX -- distant stations . . . FM -- Frequency Modulation -- the transmitting frequency is varied at an audio rate      QRM -- interference from other signals . . . QRN -- interference-static      QRX -- Standby . . . QSL -- usually a card which verifies contact or acknowledges specific transmission . . . QSO -- a contact between two stations . . . QSY -- change operating frequency . . . RF Gain Control -- radio frequency gain control: controls the sensitivity of the radio frequency amplifier stage . . . RST -- readability, strength, tone . . . SWL -- short-wave listener.

## Official Radiotelegraph Signals [Police, fire, citizens band, etc.]

10-1	Receiving poorly	10-11	Remain in service
10-2	Receiving well	10-13	Advise weather and load conditions
10-3	Granted	10-14	Correct time
10-4	Received	10-18	Anything for us?
10-5	Relay	10-19	Nothing for you
10-6	Standby	10-20	What is your location?
10-7	Out of service	10-21	Too weak, talk louder
10-8	In service	10-22	Too loud
10-9	Repeat, conditions bad	10-23	Frequency check
10-10	Out of service -- subject to call	10-24	Give a test

## International Morse Code

Letter	Phonetic Sound	Dot-Dash Sequence	Letter	Phonetic Sound	Dot-Dash Sequence
A	di-dah	--	T	dah	-
B	dah-di-di-di	....	U	di-di-dah	..-
C	dah-di-dah-dit	....	V	di-di-di-dah	....
D	dah-di-dit	---	W	di-dah-dah	--
E	dit	.	X	dah-di-di-dah	..--
F	di-di-dah-dit	..-	Y	dah-di-dah-dah	....
G	dah-dah-dit	---	Z	dah-dah-di-dit	....
H	di-di-di-dit	----	Numbers		
I	di-dit	..	1	di-dah-dah-dah-dah	-----
J	di-dah-dah-dah	----	2	di-di-dah-dah-dah	----
K	dah-di-dah	..-	3	di-di-di-dah-dah	----
L	di-dah-di-dit	....	4	di-di-di-di-dah	....
M	dah-dah	--	5	di-di-di-di-dit	....
N	dah-dit	-.	6	dah-di-di-di-dit	....
O	dah-dah-dah	---	7	dah-dah-di-di-dit	....
P	di-dah-dah-dit	---	8	dah-dah-di-di-dit	....
Q	dah-dah-di-dah	....	9	dah-dah-dah-dah-dit	-----
R	di-dah-dit	..-	0	dah-dah-dah-dah-dah	-----
S	di-di-dit	...-			

## How to Set Up Your Receiver

Your Hallicrafters Model S-118 Mark II is a Communications Receiver designed and manufactured to the most stringent quality standards. It has been packaged to insure safe arrival.

First, carefully lift the receiver out of the shipping carton and remove the specially coated wrapping paper.

Inspect the receiver for any visible damage.

Decide where you want to set up the receiver. In making your decision, you should consider several things:

- 1 ● **YOUR COMFORT** You will spend many fascinating hours with your receiver. Be sure you place it where you will be able to enjoy tuning and listening at any time.
- 2 ● **YOUR ANTENNA** The first time you turn the receiver on and start your adventure in short wave listening you will most likely be using a 15-foot length of antenna wire. As you get more experience and begin reaching out for more distant stations you may want to set up an outside antenna. With this in mind, try to choose a location which is near a window or outside wall.
- 3 ● **YOUR GROUND** Should you progress to an outside antenna it is GOOD PRACTICE TO GROUND YOUR SET FOR SAFETY. This will require running a ground wire from the ground connection on the back of the receiver to a cold water pipe or to a metal pipe driven into the earth.

Now let's set up the SHORT WAVE antennas needed to operate your receiver. Attach the length of antenna wire to terminal marked A. Extend it about the room or out a window.

Your LW and AM (BROADCAST BAND) antenna (Band 1 and Band 2) is already built into your receiver. No setup is required.

To complete your initial installation, plug your receiver into an electrical outlet which provides 105- to 125-volt, 50/60-cycle, AC only. Power consumption is 33 watts. This is the type of electrical supply common throughout the United States.

Now let's look at some of your receiver features and controls.

*hallicrafters*

# MODEL S-118 MARK II FIVE BAND COMMUNICATOR

**COVERAGE:** The S-118 Mark II receiver has five individual bands: a Long Wave Band covering 150 KC to 475 KC; a Broadcast Band covering 500 KC to 1500 KC; plus three Short Wave Bands which provide continuous coverage from 1.7 MC to 21 MC.

**BAND 1 - Long Wave** reception covering current and old time weather and navigation reports.

**BAND 2 - Standard AM Broadcast** station reception. The intermediate circuit frequency may be increased to 500 KC.

**BAND 3 - Spans 1.7 to 4.6 megacycles (MC)** range. Marine and aviation broadcasts and weather bulletins, weather forecasts can be heard on this band. The exact time broadcast by world time standard station WWV may be tuned in at 2.5 MC. The same time broadcasting at 3.5 MC is the 40-meter amateur radio band. All same sites (other lines) located above the main lines of bands 2 through 5 designate the amateur radio bands in meters. (Page 4 shows the meter-frequency relationships.)

**BAND 4 - covers 5.0 to 10 megacycles (MC).** This short wave band carries international broadcasts from distant countries, the 40- and 20-meter amateur radio bands, and WWV located at 5 and 10 MC.

**BAND 5 - Includes 15 to 20 megacycles (MC).** International broadcasts from many places can be found in this band in addition to the 15- and 10-meter amateur radio bands and 20 same band stations. WWV time can be checked on this band at 15, 20, and 25 MC.

**SPEAKER:** 4-ohm permanent magnet, 2.7-ohm voice coil.

**PHONES:** Front panel jack for plugging in any commercial low-impedance headphones ranging from 3 to 2000 ohms. With headphones plugged in the receiver, the built-in speaker will be disconnected.

**SENSITIVITY CONTROL:** Control set fully clockwise for maximum sensitivity. Should hiss or background noise be heard, or strong signals cause distortion, reduce the sensitivity by turning the control slowly counterclockwise. If this action reduces volume, advance the VOLUME control.

**REC-STAY SWITCH:** Normally set to REC (receive). When in STAY position, the receiver is ON and remains at existing frequency and the speaker or headphones will be disconnected, no sound is heard. The STAY feature allows through the direct warming of the tubes for use as local or distant tuned stations. With the receiver preset, inserting the STAY feature permits listening at the receiver and direct return of frequency to REC.

**BAND SELECTOR CONTROL:** When the band selector knob indicates the corresponding band on the dial, the receiver is being tuned.

OFF

OFF -  
re-  
increa  
A'low  
& slig  
re 2.

# COMMUNICATIONS RECEIVER

## Identification of features and controls

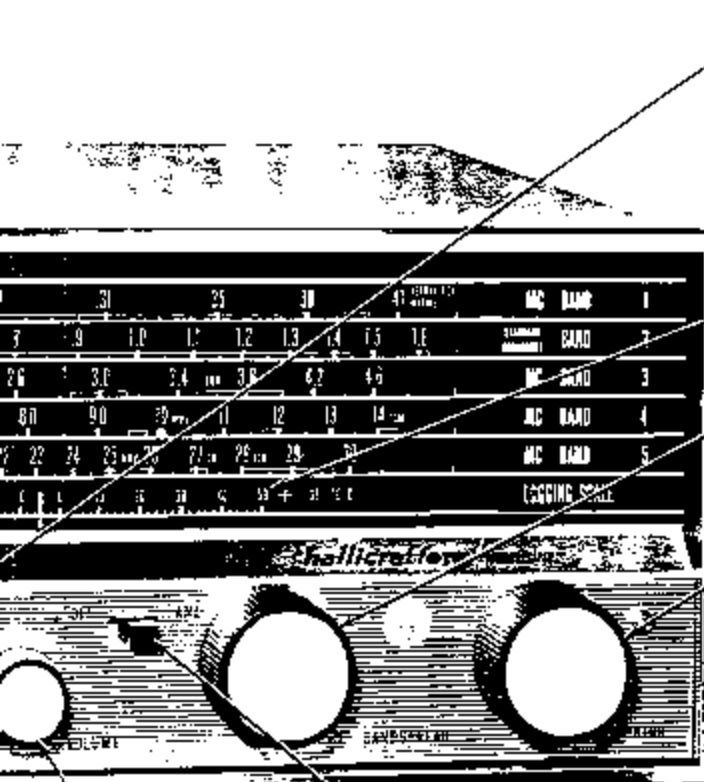

**OFF-B.F.O. SWITCH:** This switch is primarily used to provide the necessary beat frequency tone when receiving CW coded signals, or single sideband. Set it to OFF for CW signals, or for FM broadcast reception. When listening to CW signals, advance the VOLUME control to maximum, fully clockwise, and adjust the SENSITIVITY control to a comfortable volume level. Many voice stations using Single-Sideband Suppressed Carrier Transmission. In order to receive this type signal, it will be necessary to switch B.F.O. OFF. Tuning will be more critical. The SENSITIVITY control should be set toward minimum and the VOLUME control advanced toward maximum.

**LOGGING SCALE:** Professional microphone-type ear which reads in one-thousandths of a megacycle. The yellow pointer, moved by the BANDSPREAD control, indicates reading on the LOGGING SCALE.

**BANDSPREAD CONTROL:** Similar to a fine tuning control, only far more sensitive. Use for fine tuning or for using Main Tuning Control to move red pointer to approximate dial location of station you wish to receive. Electrically expands dial reading 100 times. Control, move yellow pointer on LOGGING SCALE.

**TUNING CONTROL:** Use for regular or fast tuning. Moves the pointer to dial location. Adequate for tuning most Standard Broadcast stations and for scanning the Short Wave Bands.

### SPECIFICATIONS

- ANTENNAS:** Self-contained ferrite loopstick for Band 1 and Band 2 (broadcast). Two contact, screw-type terminal strip on rear panel for external antenna of 22 wires to 500 ohm impedance for Band 3, Band 4, and Band 5.
- TUBES:** Five: 6BE6 Mixer, 12BA6 F Amplifier, 12SA6 IF Amplifier, 6F6, 12AV6 First Audio Detector, AVC ANL: 6AD5A Audio Detector; plus two silicon diodes.
- PANEL LAMPS:** Two type NO. 44.
- PHYSICAL DATA:** Grey peel cabinet with silver trim. Size: 6-3/8 inches high by 18-1/2 inches wide by 8-3/4 inches deep. Approximate weight: 15 pounds.

**OFF-ON/VOLUME CONTROL:** Turn receiver On (clockwise) and OFF (counterclockwise). Volume is increased as control is turned in the clockwise direction. Allow one minute for warmup after turning receiver ON. A slight hum is normal. To cut hum, insert plug in the electrical outlet in room in which the receiver is used.

**OFF-ANL SWITCH:** This switch is normally set at OFF. Increase station volume with reception, place the switch in the ANL position. This will reduce interference. However, some control of all speech and music reproduction may result.



hallicrafters

## How to Operate Your Receiver

Some of the basics, such as setting up your receiver and plugging it in have already been covered. Now you are ready to start listening. Here's how:

A good way to become familiar with your receiver is to first try it out on Band 2, the Standard AM Broadcast Band. You will find that stations with which you are familiar come in loud and clear. You will also discover many other stations which you may never have heard before.

### Getting Ready to Tune Your Receiver

1. Turn receiver ON by turning the OFF/VOLUME Control to the right. The dial will light up.
2. Place the REC/STBY Switch into the REC position.
3. Place the BFO switch in the OFF position.
4. Turn the BANDSPREAD Control until the short yellow pointer is at 0 on the LOGGING SCALE.
5. Select the band to which you wish to tune by turning the BAND SELECTOR Control to the appropriate band number.

### Tuning Long Wave (Band 1) and AM Broadcast (Band 2)

1. Turn BAND SELECTOR Control to the Band 1 or Band 2 setting.
2. Using the TUNING Control, move the red pointer to the station frequency desired.

### Tuning Short Wave Stations

The transmission of short wave signals is a more precise operation. Reception of these signals is subject to several things which are, for the most part, beyond the control of your receiver. These are: 1) atmospheric conditions such as solar disturbances which can help make a signal come in loud and clear, reduce signal strength and clarity or even block it out completely, 2) day-to-night and month-to-month atmospheric variance, and 3) your skill as a Short Wave Listener in tuning your receiver. These skills are quickly developed, however, and a good way to start is Dial Scanning.

#### Dial Scanning Method

1. Select the band you wish to scan (by tuning through the entire band) by turning the BAND SELECTOR Control to Band 3, 4, or 5.
2. Adjust the yellow pointer on the LOGGING SCALE to about 0 by turning the BANDSPREAD Control.
3. Slowly move the red pointer across the dial, using the TUNING Control. You will alternately hear nothing, a few squeals, and then dots and dashes, voice, or music.
4. After you have tuned in as fine as you can with the TUNING Control, use the BANDSPREAD Control. Slowly move the yellow pointer, first from 0 to +50, and then down through 0 toward -50 until you bring a station in clearly.
5. You will notice as you scan the dial you can hear CW code (dots and dashes) if you wish to hear the code with the clarity required to read it, turn the BFO switch ON and adjust the SENSITIVITY control to the point which gives the clearest tone. You can make the tone sound higher or lower by turning the BANDSPREAD Control.

- 6 By waiting until the station identifies itself, you can log the station call letters, country and city of origin, transmitting frequency, and the time of reception so that you can tune in again at a later date. (See Station Log starting on Page 11.) For future location of the station, note the numbers indicated by the red and yellow pointers. For example: if the Band frequency is indicated as 8.0 and the LOGGING SCALE yellow pointer shows +22, the dial location should be logged as 8.022.

TUNING A SPECIFIC STATION follows the same steps as for Dial Scanning, except that you start with a specific frequency selected from your Station Log (see page 11). For example: if you wish to tune Radio MOSCOW you will see that one of the frequencies is 9.805. Taking 9.805 to demonstrate you would:

- 1 Turn the BAND SELECTOR Control to Band 4.
- 2 Make sure the yellow LOGGING SCALE pointer is at 0.
- 3 Move the red pointer slightly above 8 on Band 4 with the TUNING Control.
- 4 Then, with the BANDSPREAD Control, slowly move the yellow pointer from 0 on the LOGGING SCALE to the vicinity of +5. NOTE: You may find that the station comes in a little below or above the +5 mark on the scale. Adjust if you wish.
- 5 Procedure for using the BFO switch for CW (code) or voice or music reception is the same as in Dial Scanning.

### Questions on Service or Operation

Most service problems are relatively minor. For example: if you hear a disturbing buzz, when trying to tune in a weak station, chances are it is being caused by a fluorescent light. Look for the cause and, if you can, turn it off.

If the receiver is ON, but you hear nothing, look to see if the REC/STBY Switch is in the Receive position.

When you turn the OFF/VOLUME Control to ON and nothing happens, look to see if the receiver is securely plugged into the electrical outlet.

If signals are coming in very weak, check to see if your antenna wire is securely connected.

For further information regarding operation or servicing of this equipment, contact the dealer from whom the unit was purchased. The Hallicrafters Company maintains an extensive system of Authorized Service Centers where any required service will be performed promptly and efficiently at no charge if this equipment is delivered to the service center within 90 days from date of purchase by the original buyer and the defect falls within the terms of the warranty. It is necessary to present the Bill-of-Sale in order to establish warranty status. After the expiration of the warranty, repairs will be made for a nominal charge. All Hallicrafters' Authorized Service Centers display the sign shown at the right. For the location of the one nearest you, consult your dealer or your local telephone directory.

No service shipments should be made to the factory, unless instructed to do so by letter, as The Hallicrafters Company will not accept the responsibility for unauthorized shipments.

The Hallicrafters Company reserves the privilege of making revisions in current production of equipment and assumes no obligation to incorporate such revisions in earlier models.



## THE ANTENNA

All short-wave receivers need an antenna. A better antenna will receive signals that are weak and far away. Chances are you'll do very well with the antennas provided.

More elaborate antennas generally are built either to operate on one frequency, or to perform with effective results over a wide band of frequencies.

Because most listeners want results on all short-wave frequencies covered by their receiver, a suitable antenna for general coverage is illustrated.

This antenna will produce the best reception when it is mounted high and clear away from power lines, trees, and surrounding objects.

Listeners desiring specific design information on more specialized antennas are referred to the "A.R.R.L. Antenna Book" published by the American Radio Relay League.

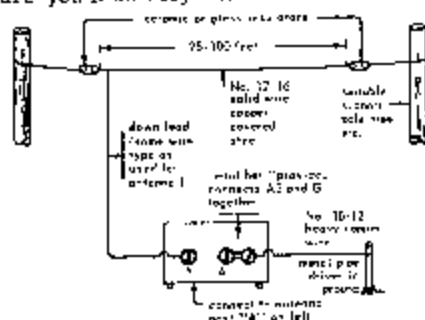

## Megacycles to Meters

All modern communication receivers are calibrated in megacycles. None the less, it is sometimes helpful to know what meter band corresponds to 11.866 megacycles for example. This is particularly true when tuning the International Short Wave Broadcasting stations who often announce only in meters. Megacycles may be converted to meters through the use of this simple formula:

$$300/\text{Megacycles} = \text{Meters}$$

For example:

$$300/11.866 = 25.28$$

or 11.866 MC = 25.28 meters

The conversion from meters to megacycles uses the same formula:

$$300/\text{meters} = \text{megacycles}$$

For example:

$$25.28 \text{ meters}$$

$$300/25.28 = 11.866 \text{ MC}$$

## Reference Material

Here are sources through whom a logbook with listing of foreign and local stations, as well as other information of interest to both radio and short-wave listeners, may be obtained:

AMERICAN RADIO RELAY LEAGUE, 38 La Salle Rd., West Hartford, Conn. Official organization of radio amateurs in the U.S. Free literature. Special publications on how to become a radio amateur.

WORLD RADIO HANDBOOK, available through Giltner Associates, BLX 239, Park Ridge, New Jersey. Yearly handbook of all short-wave stations, printed in Denmark.

POPULAR ELECTRONICS, 1 Park Avenue, N.Y. 16, N.Y. Monthly magazine available on newsstands. General news and features for the electronics hobbyist; excellent regular column on short-wave listening plus occasional SWL feature stories.

## TIME AND INTERNATIONAL BROADCASTING

Communications time is told on a 24-hour clock. One AM is 0100; 4 AM is 0400, Noon is 1200; 3:30 PM is 1530; 8:45 PM is 2045, etc. With this method, there can be no confusion between AM and PM.

The base for telling time in International Broadcasting is Greenwich Mean Time, GMT, the time at Greenwich Observatory in England.

Converting from GMT to a local time zone is accomplished by adding or subtracting the hours shown on the INTERNATIONAL TIME MAP. For example: 1000 GMT is 0400 in CST (Central Standard Time).

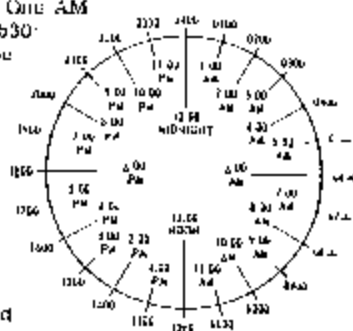

Conversion from GMT to any other time zone is likewise accomplished by adding or subtracting hours. The chart for this is shown at the bottom line on the INTERNATIONAL TIME MAP.

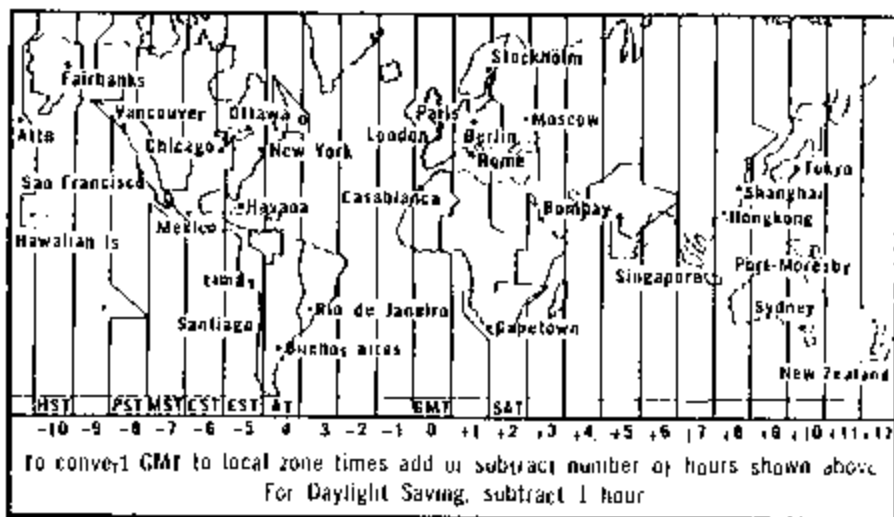

### International Station Log

Instructions for use --- International Station Log

Short wave listeners will find the following pages of great use in spotting and identifying international short-wave broadcasting stations operating from locations around the globe. The "Log" is prepared by broadcast frequencies. A column is provided for listing "Local Time Heard." Conversion from GMT to local time is explained above.

Stations listed in the log can be heard by listeners throughout the North American Continent. Transmission periods vary throughout the day and night. All broadcasts are in the English language unless otherwise indicated.

Column five, TYPE PROGRAM is included in the log so that you may list the type of broadcast you heard. The following abbreviations will be of assistance in filling out that column.

NE	News in the English language	ML	Music, English
EI	Commentary in English	MS	Music, Spanish
SI	Commentary in Spanish.	MN	Music, native to the country of location.

ND - Indicates station does not broadcast daily.

In addition to the transmissions listed in the log, you will hear many English language broadcasts from such countries as Canada, Great Britain, and the United States. Because of the great volume of such broadcasts, and as they are easily heard without consulting a prepared guide, we have listed only a few such stations.

## STATION LOG

COUNTRY OF ORIGIN	CITY OF ORIGIN	CALL LETTERS	FREQUENCY IN MEGACYCLES	TYPE PROGRAM	LOCAL TIME HEARD
Liberia	Monrovia	ELBC	3.255		
British Honduras	Belize		3.300		
Ghana	Accra		3.365		
S. Africa	Faradya		4.810		
Singapore		FBS	5.010		
Tanzania	Dar-es-salaam		5.050		
Ethiopia	Addis Ababa		5.060		
Brazil	Sao Paulo	ZYR226	5.955		
Germany	Ismaning		5.960		
Dominican Republic	Ciudad	Radio Caribe	5.970		
North Borneo	Jessalton		5.980		
Haiti	Cap. Nation	4VR	5.980		
Romania	Bucharest		5.990		
Belgium	Brussels	DRU	6.000		
Egypt	Abu Zabal		6.015		
Rhodesia	Salisbury		6.020		
Morocco	Tangier		6.025		
Iraq	Abu Ghurayb		6.030		
England	Derentry	GWS	6.035		
Monaco		3M3	6.037		
China	Nanking	BCA22	6.040		
Indonesia	Djakarta	YDF	6.045		
Nigeria	Ibadan		6.050		
Poland	Warsaw		6.055		
Canada	Sackville N.B.	CKR2	6.060		
India	Delhi		6.065		
U.S.S.R.	Minsk		6.075		
Canada	Hallifax		6.100		
England	London	BBC	6.110		
Morocco			6.115		
Japan	Tokyo	RON	6.160		
Mexico	Mexico City		6.165		
Switzerland	Berne		6.165		
Nigeria	Kaduna		6.175		
North Korea	Pyongyang		6.195		
North Korea	Pyongyang		6.250		
Egypt	Cairo		7.051		
Taiwan	Chiayi		7.100		
Congo	Brazzaville		7.105		
Okinawa	Naha	VOL	7.160		
Hungary	Budapest		7.220		
Pakistan	Karachi		7.280		
East Germany	Berlin		7.300		
Czechoslovakia	Prague		7.340		
U.S.S.R.	Moscow	Radio Moscow	7.555		
Belgium	Brussels		9.144		
Bulgaria	Sofia		9.255		
China	Peking		9.480		

COUNTRY OF ORIGIN	CITY OF ORIGIN	CALL LETTERS	FREQUENCY IN MEGACYCLES	TYPE PROGRAM	LOCAL TIME HEARD
Denmark	Copenhagen	OIF	9.520		
Cuba	Havana		9.534		
Hong Kong	Lugan		9.535		
Switzerland	Berne		9.535		
New Zealand	Wellington	ZLZ	9.540		
Czechoslovakia	Prague		9.580		
Windward Islands	St. George's	WBBS	9.550		
Hungary	Budapest		9.570		
Italy	Rome	RAI	9.575		
Canada	Montreal	CBC	9.585		
Mozambique	Luanda				
	Maputo	CB7HJ	9.610		
Sweden	Stockholm	Radio Sweden	9.665		
Argentina	Buenos Aires	LRA	9.690		
Dominican Republic	Santiago	Radio Caribe	9.735		
China	Peking		9.785		
U.S.S.R.	Moscow	Radio Moscow	9.805		
Windward Islands	Barbados	2MX30	11.475		
U.S.S.R.	Moscow	Radio Moscow	11.570		
Egypt	Cairo		11.665		
Thailand	Bangkok	HSK9	11.670		
Pakistan	Karachi		11.674		
Sweden	Stockholm	Radio Sweden	11.705		
India	New Delhi		11.710		
Australia	Melbourne	YLA	11.710		
Norway	Oslo		11.720		
Windward Islands	St. George's		11.735		
Morocco	Rabat		11.755		
Vietnam	Hanoi City	HVJ	11.760		
Canada	Montreal	CBC	11.760		
Indonesia	Djakarta		11.765		
Australia	Melbourne	YLA	11.810		
U.S.S.R.	Moscow	Radio Moscow	11.810		
Bulgaria	Sofia	BBU	11.850		
Katanga	Elisabethville		11.866		
Philippines	Manila	QZF2	11.920		
Spain	Barcelona		11.925		
Singapore	Singapore	BBC RES	12.955		
China	Peking		12.125		
Iran	Tehran	2PB	15.125		
Japan	Tokyo	JOA15	15.175		
Finland	Helsinki	OJK4	15.190		
Canada	Montreal		15.190		
Liberia	Monrovia	ELWA	15.198		
Taiwan	Taipei	8ED2	15.235		
Yugoslavia	Belgrade		15.240		
Sweden	Stockholm	Radio Sweden	15.240		
Israel	Tel Aviv		15.250		
Ceylon	Columbo		15.265		
Poland	Warsaw		15.275		
New Zealand	Wellington	ZLA	15.280		
Australia	Melbourne	YLA	15.315		
France	Paris		15.350		
United States	New York City	WRUL	15.380		
West Germany	Cologne	DMQ15	15.405		
South Korea	Seoul	MLXP	17.745		
United States	New York City	WRUL	17.750		
Portugal	Lisbon	CSA44	17.870		

*the new ideas in electronics*



*are born at ..... hallicrafters*



**Provision Amateur Radio** ♦ One of the few remaining avenues of uncensored personal communication among the peoples of the world is amateur radio. Hundreds of thousands of individuals from all walks of life, in 92 nations of the world (over half in the United States alone) devote much of their spare time to this fascinating and useful activity. Far more than a hobby, "ham" radio is America's front line of defense in communication in times of national emergency or disaster. Hallicrafters manufactures more precision communications equipment for the amateur than any other company in the world. Its technological leadership has been acknowledged for 30 years.

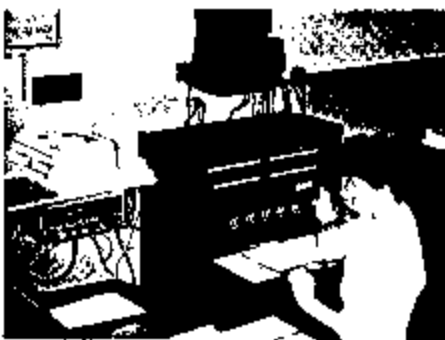

**Personal Communication** ♦ In this age of exotic communications, space probes and satellites, has come a simple but tremendously important opportunity for private citizens to communicate. It is called Citizens Band Radio.

Any adult with a need for personal two-way radio communication can own and operate a citizens band radio. No operator's license is required, only an easily-obtained station license, making it ideal for business and professional men who must be away from their phones frequently.

Nearly a million sets are now in use in homes, offices, cars, tractors, boats, and in industry. From its earliest stages, Hallicrafters has been

a pioneer in Citizens Band Radio. Many of the major technical developments have come from Hallicrafters' electronic research laboratories. Today's Hallicrafters Citizens Band Radios are setting industry standards for compactness, for versatility, and outstanding performance.

Here, once again, is a working demonstration of new ideas in electronics, born at Hallicrafters for you.



**Aerospace Electronics** ♦ For a quarter century Hallicrafters has played a significant and special role in America's military defense. In addition to its widely used military communications equipment, Hallicrafters pioneered with the United States Air Force in the development of special research and development techniques known as "QRC," or Quick Reaction Capability, which have kept America ahead in the critical race for supremacy in electronic counter measures, reconnaissance, and other electronics warfare equipment. Today, advanced devices designed and manufactured by Hallicrafters aerospace division are at work in every phase of missile development from tracking system to nose cone.



*hallicrafters*

## WARRANTY

The Hallicrafters Company warrants its products to be free from defective material and workmanship and agrees to remedy any such defect or to furnish a new part in exchange for any part of any unit which under normal installation, use and service discloses such defect, provided the unit is delivered by the owner to our authorized radio dealer, wholesaler, new unit purchaser, or authorized service center, inasmuch as examination, with all transportation charges prepaid within ninety days from the date of sale to original purchaser and provided that such examination discloses to our judgment that it is thus defective.

This warranty does not extend to any of our radio products which have been subjected to misuse, neglect, accident, incorrect wiring or use, or improper installation, or to any in violation of instructions furnished by us, nor extended to units which have been repaired or altered outside of our factory or authorized service center, nor to cases where the serial number (plate) has been removed, defaced or changed, nor to accessories used therewith not of our own manufacture.

Any part of a unit approved for repair or exchange hereunder will be remedied or exchanged by the authorized radio dealer or wholesaler without charge in the future.

This warranty is in lieu of all other warranties, expressed or implied and no representative or person is authorized to assume for us any other liability in connection with the sale of our radio products.

*The hallicrafters* CO.

156-501223

**NOTE:** Fill out and return immediately the enclosed  
**WARRANTY CARD**

Record equipment information for future reference

### RECEIVER:

Model number \_\_\_\_\_

Serial number \_\_\_\_\_

Date purchased \_\_\_\_\_

Purchased from \_\_\_\_\_

### ACCESSORIES:

\_\_\_\_\_ # \_\_\_\_\_

\_\_\_\_\_ # \_\_\_\_\_

\_\_\_\_\_ # \_\_\_\_\_

For maximum enjoyment from your equipment . . . read your  
Owner's Guide before you start operating your receiver.

# SERVICE REPAIR PARTS LIST

Schematic Symbol	Description	Manufacturer Part Number	Schematic Symbol	Description	Manufacturer Part Number	Schematic Symbol	Description
<b>CAPACITORS</b>			<b>RESISTORS (cont.)</b>			<b>ELECTRON TUBES, DIODES AND TUBE SOCKETS</b>	
C1	Variable, BANDSPREAD	048-000555	R17	220K ohm	451-252924	V1	6BE6, Mixer-Oscillator
C2	0.05 $\mu$ F, 20%, 100V, Ceramic Disc	047-001649	R10	100K ohm	451-252104	V2	12BA6, IF Amplifier
C3 4, 5, 6, 7	Variable, Antenna Tuning Assembly	044-002597	R20	56 ohm, 2 wpts	451-252566	V3	12BA6, IF Amplifier-BFO
C9	Variable, TUNING	048-000554	R21	470 ohm, 1 watt	451-252471	V4	12AV6, First Audio-Converter - AVC - AML
C10	220 $\mu$ F, 2.5%, 500V Plastic	505-201231	R27	1500 ohm, 2 wpts	451-252152	V5	6AD5A, Diode
C11	4.7 $\mu$ F, 10%, 500V Composition	047-200402-06	R24	15K ohm, 1 watt	451-252153	CV1 2	IN5194, Silicon Rectifier Socket, 4-Pin
C12	16 $\mu$ F, 10%, 500V NFD Ceramic Tubular	401-106150-22	R25	Variable, 10K ohm, 20%, 2 wpts, SENSITIVITY	015-002236	CV2, 3, 4, 5	IN5194, Silicon Rectifier Socket, 7-Pin
C13, 14, 15	0.01 $\mu$ F, $\pm$ 50% -20% 500V Ceramic Disc	047-100228	R2	470K ohm	451-252874	<b>MSCCELLARODES</b>	
C16 17, 18	0.02 $\mu$ F, $\pm$ 50%, 20% 500V Ceramic Disc	047-100242	R3	270 ohm, 1 watt	451-252971	Bracket Assembly, Dial Plate Mounting	
C19, 22, 24	1 $\mu$ F, 10%, 500V Composition	047-200402-03	R28	47 ohm, 1 watt	451-252470		
C20	100 $\mu$ F, 1000V, Ceramic	047-051789	R29	4.7 ohm	451-252047	Bracket Assembly, Powder Rail Cabinet Comp. Loop	
C23, 26, 27 *	0.002 $\mu$ F, 20%, 1000V Ceramic Disc	047-100794	*All RESISTORS are 10%, 1/2 watt unless otherwise specified				
C25, 46, 47	51 $\mu$ F, 10%, 500V NFD Ceramic Tubular	401-006210-22	<b>CDRLS AND TRANSFORMERS</b>			Clip, IF Transformer Mounting	
C27	Variable, Oscillator Tuning Assembly	044-000595	L 1	7 mil, Airmao (capacitive load)	05-000432		
C30, 31, 34	2400 $\mu$ F, 2.5%, 500V, Plastic	505-201242	L	Coil, Antenna, Base 1	051-003467	Dial Cord	
C31	1900 $\mu$ F, 2.5%, 500V, Plastic	505-201137	L3	Coil, Antenna, Band 4	050-001908		
C32	390 $\mu$ F, 2.5%, 500V, Plastic	505-201071	L4	Coil, Antenna, Band 5	051-003404	Dial Glass, Col. Broken	
C33	500 $\mu$ F, 2.5%, 500V Plastic	505-201231	S	Coil, Antenna, Band 2	050-001229		
C39, 40, 41	0.01 $\mu$ F, 60V, 1400V Ceramic Disc	047-200759	16	Coil, 700 ohm, RF Cross	050-001064-10	Face, Plastic	
C42A, B	10 $\mu$ F, 50V, 40V, 700V	045-000652	t	Coil, Oscillator, Band 5	051-003409		
C43	45-45 $\mu$ F, 50V, Electrolytic	045-000651	1M	Coil, Oscillator, Band 4	05-002400	Inner Case	
C44	0.1 $\mu$ F, 20%, 200V, Paper	046-001294-05	L9	Coil, Oscillator, Band 3	051-003407		
C45	0.001 $\mu$ F, 500V, Ceramic Disc	047-001671	L15	Coil, Oscillator, Band 2	051-003406	Knob, BAND SELECTOR and VOLUME	
			L11	Coil, Oscillator, Band 1	051-003405		
			R 1, 2, 3	Transformer, IF, 455K <sup>1</sup>	050-000945	Knob, SENSITIVITY	
			T4	Transformer, Power	052-001518		
			T5	Transformer, Output (Part of SP1)	-----	Loop Pilot (Ins. w/ Linc Card and Plug Jack), Line Card	
			<b>SWITCHES AND CONNECTORS</b>				
R	15 ohm	451-252150	S1	Switch, Rotary, BAND SELECTOR	060-007647	First Lame Assembly	
R2	25K ohm	451-252223	S2	Switch, Slide, SPDT, RFCEIVE-STANDBY	060-002565		
R3	47 ohm	451-252470	S3	Switch, Slide, DPDT, BFO-OFF	060-007641	Photo, Dial Background	
R4, 11	1200 ohm	451-252132	S4	Switch, ON/OFF (Part of R16)	-----		
R5, 6	7.2 megohm	451-252935	S5	Switch, Slide SPB	060-007550	Pointer, Bandspread	
R7	4700 ohm	451-252474	S6	Switch, Slide SPB	-----		
R8	210K ohm	451-252274	S7	Connector, Socket	016-100041	Pointer, Main Tuning Rail, Power	
R9	220 ohm	451-252221	S8	Connector, Socket, Enamel Audio	016-100041		
R10	12K ohm	451-252126	S9	Connector, Socket, BIKINES	016-100041	Ring, Retaining	
R11	1 megohm	451-252125	S10	Connector, Socket, Enamel Audio	016-100041		
R12	68 ohm	451-252680	S11	Connector, Socket, Enamel Audio	016-100041	Shaft, Bandspread	
R14	Variable, 500K ohm, 20%, 1/4 watt, VOLUME (inc SP1)	025-002316	S12	Connector, Socket, Enamel Audio	016-100041		
R15	4.7 megohm	45-232475	S13	Connector, Socket, Enamel Audio	016-100041	Shaft, Main Tuning Shield, Electron Tube (V), 3, 4	
R16	100 ohm	45-232475	S14	Connector, Socket, Enamel Audio	016-100041		
R17	220 ohm	45-232475	S15	Connector, Socket, Enamel Audio	016-100041	Shield, Pilot Lamp	
R18	100 ohm	45-232475	S16	Connector, Socket, Enamel Audio	016-100041		
R19	100 ohm	45-232475	S17	Connector, Socket, Enamel Audio	016-100041	Screw, Pointer Rail Mounting	
R20	56 ohm, 2 wpts	451-252566	S18	Connector, Socket, Enamel Audio	016-100041		
R21	470 ohm, 1 watt	451-252471	S19	Connector, Socket, Enamel Audio	016-100041	Strip, Cabinet	
R22	Variable, 10K ohm, 20%, 2 wpts, SENSITIVITY	015-002236	S20	Connector, Socket, Enamel Audio	016-100041		
R23	1500 ohm, 2 wpts	451-252152	S21	Connector, Socket, Enamel Audio	016-100041	Tape Strip, Cabinet	
R24	15K ohm, 1 watt	451-252153	S22	Connector, Socket, Enamel Audio	016-100041		
R25	Variable, 10K ohm, 20%, 2 wpts, SENSITIVITY	015-002236	S23	Connector, Socket, Enamel Audio	016-100041	Tape Strip, Cabinet	
R26	470K ohm	451-252874	S24	Connector, Socket, Enamel Audio	016-100041		
R27	1500 ohm, 2 wpts	451-252152	S25	Connector, Socket, Enamel Audio	016-100041	Tape Strip, Cabinet	
R28	47 ohm, 1 watt	451-252470	S26	Connector, Socket, Enamel Audio	016-100041		
R29	4.7 ohm	451-252047	S27	Connector, Socket, Enamel Audio	016-100041	Tape Strip, Cabinet	
R30	4.7 ohm	451-252047	S28	Connector, Socket, Enamel Audio	016-100041		

# ALIGNMENT

- Use an amplitude modulated signal generator covering 135 KC to 31 MC
- Connect the output meter across the speaker voice coil.
- Use a non-metallic alignment tool
- Connect a 27-ohm carbon resistor between the generator and the receiver

Step	Signal Generator Connections	Generator Frequency	Band Selector Setting	Receiver Dial Setting	Adjust
1	High side through 0.01- $\mu$ f capacitor to pin 2 of V1; low side to chassis ground.	455 KC (modulated 30%)	2	Center of dial	Alignment points A, B, C, D, E, and F for maximum output. Reduce the generator output to maintain meter indication below 50 milliwatts.
2	High side through 27-ohm resistor to terminal A on rear panel; low side to terminal G.	1400 KC (modulated 30%)	2	1400 KC	Adjust C36 (oscillator) and C3 (antenna) for maximum output.
3	Same as step 2	550 KC (modulated 30%)	2	550 KC	Adjust L10 (oscillator) and L5 (antenna) for maximum output.
4	Same as step 2	...	2		Repeat steps 2 and 3 until no increase in output can be obtained with either adjustment.
5	Same as step 2	410 KC (modulated 30%)	1	410 KC	Adjust C38 (oscillator) and C7 (antenna) for maximum output.
6	Same as step 2	190 KC (modulated 30%)	1	190 KC	Adjust L1 (oscillator) for maximum output. L1 lead adjustment should not be necessary.
7	Same as step 2				Repeat steps 5 and 6 until no increase in output can be obtained with either adjustment. Then repeat steps 2 and 3.

NOTE 1 The 1000- $\mu$ f capacitor frequency is using the tuning signal on bands 2, 3, 4, and 5.

## TUBE AND DIAL LAMP REPLACEMENT

For access to the tubes remove the three screws holding the rear panel in place and remove the panel. Care should be exercised to prevent damage to the leads from the loopstick antenna mounted on this panel (see CHASSIS REMOVAL.)

## CHASSIS REMOVAL

To remove the chassis, remove the four screws securing the chassis to the cabinet and slide the chassis out the rear of the cabinet.

**CAUTION** Before removing the chassis from the cabinet rotate the MAIN TUNING and BANDSPREAD controls fully counterclockwise to prevent damaging the variable capacitors.

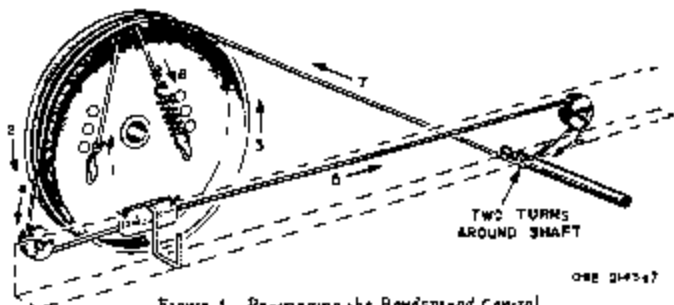

Figure 4. Restringing the Bandspread Control

# PROCEDURE

- Set REC-STBY Switch to REC; AM/CW to AM OFF-ANL to OFF; SENSITIVITY fully clockwise, VOLUME fully clockwise and BANDSPREAD at mid-scale for Bands 3, 4, and 5, fully counterclockwise for Bands 2 and 7.
- Refer to the top and bottom views for location of adjustments.

Step	Signal Generator Connections	Generator Frequency	Band Selector Setting	Receiver Dial Setting	Adjust
8	Same as step 2	4200 KC (modulated 30%)	3200	4200 KC	Adjust C34 (oscillator) and C4 (antenna) for maximum output.
9	Same as step 2	1900 KC (modulated 30%)	3	1900 KC	Adjust L9 (oscillator) and L2 (antenna) for maximum output.
10	Same as step 2	-----	3		Repeat steps 8 and 9 until no increase in output can be obtained with either adjustment.
11	Same as step 2	14 MC (modulated 30%)	4	14 MC	Adjust C32 (oscillator) and C5 (antenna) for maximum output.
12	Same as step 2	5.0 MC (modulated 30%)	4	5.0 MC	Adjust L3 (oscillator) and L3 (antenna) for maximum output.
13	Same as step 2	---	4		Repeat steps 11 and 12 until no increase in output can be obtained with either adjustment.
14	Same as step 2	30.0 MC (modulated 30%)	5	30.0 MC	Adjust C30 (oscillator) and C6 (antenna) for maximum output.
15	Same as step 2	15.0 MC (modulated 30%)	5	15.0 MC	Adjust L7 (oscillator) and L4 (antenna) for maximum output.
16	Same as step 2	---	5		Repeat steps 14 and 15 until no increase in output can be obtained with either adjustment.

and a lower than the incoming signal on band 5.

## DIAL CORD RESRINGING

Remove the chassis from the cabinet to restore return dial cord (see CHASSIS REMOVAL). Remove the dial scale by removing two screws; remove the dial plate by removing four hex-head screws. Removing the dial plate provides complete access to the drive pulleys. Exercise care when removing the dial plate to prevent damage to the pointers. Follow the arrows and number sequence in figure A for the main tuning dial and figure B for the logging scale dial. The dial cord springs should be expanded from one-quarter inch to one-half inch. Engage the dial cord with the pointer clips; replace the dial plate and dial scale. With the MAIN TUNING and BANDSPREAD controls fully counterclockwise, align the pointers to the mark on the dial scale and apply a drop of cement to the dial cord and pointer clip. Replace the chassis in the cabinet.

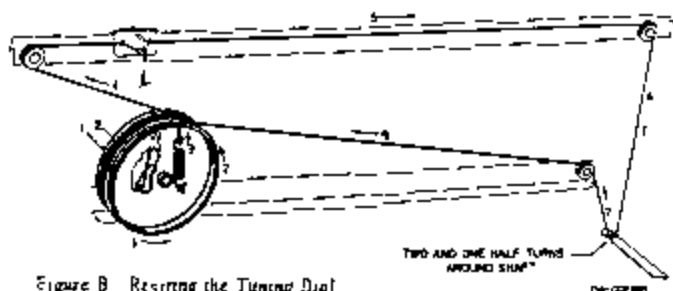
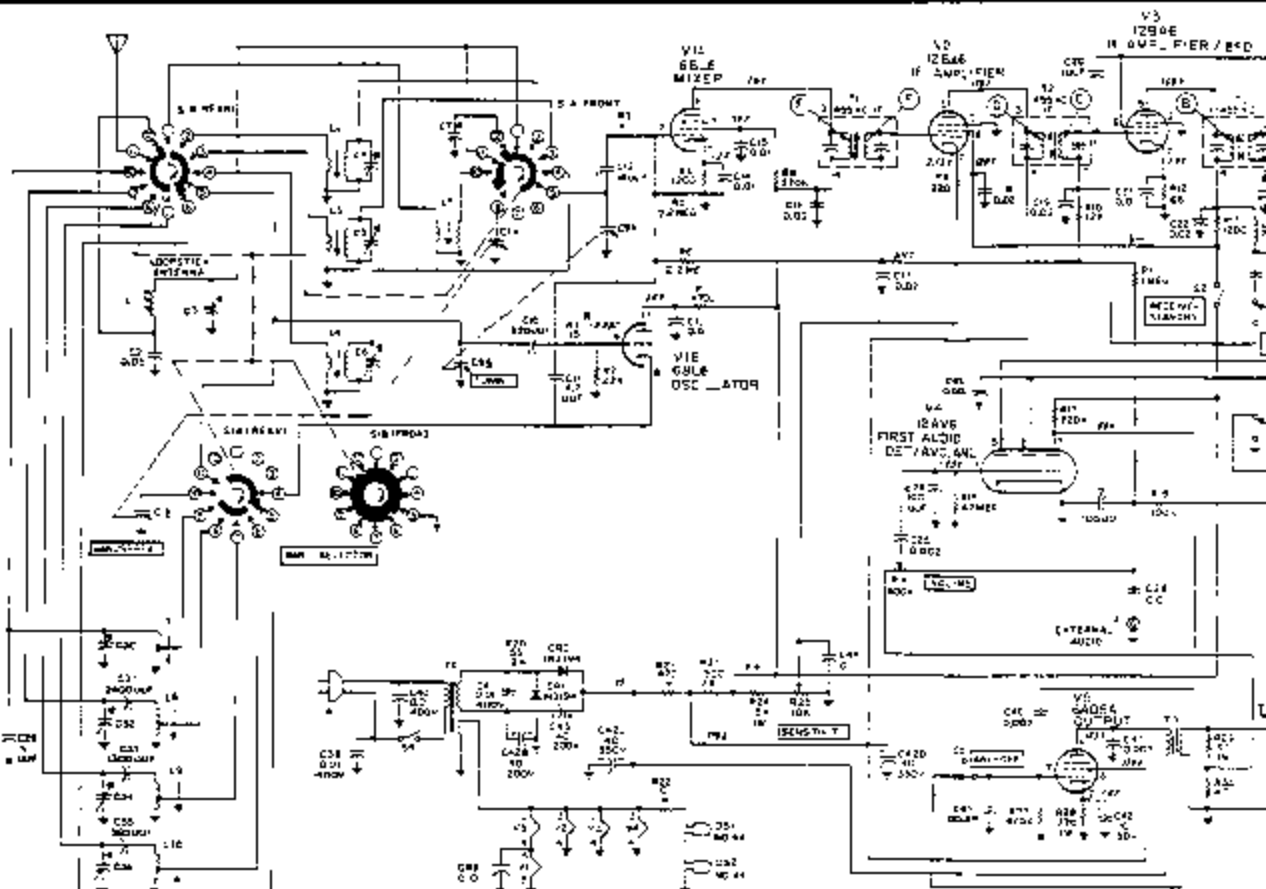

Figure B Respring the Tuning Dial



- NOTES
1. UNLESS OTHERWISE SPECIFIED ALL RESISTORS ARE IN OHMS.
  2. ALL CAPACITORS ARE IN MICROFARADS UNLESS OTHERWISE SPECIFIED.
  3. BAND SELECTOR SWITCHES ARE SET FROM THE FRONT PANEL. THE BAND SWITCH IS IN FULL COUNTERCLOCKWISE POSITION ON S.B. FRONT AND S.B. REAR ARE CONNECTED TOGETHER RESPECTIVELY. BAND 1 FROM BAND 1.
  4. BAND SELECTOR SWITCH IS IN BAND 1. BAND 1 OF VOLUME CONTROL IS IN BAND 1.

5. S2 SHOWN IN STANDBY POSITION.
  6. S3 SHOWN IN OFF POSITION.
  7. S4 SHOWN IN ALL BAND POSITION.
- INDICATES EQUIPMENT MOUNTING.
- ALL VOLTAGES ARE D.C. MEASUREMENTS WITH RESPECT TO CHASSIS GROUND UNDER NO CONDITIONS. PH BIAS CONTROL FULLY ON AT GAIN CONTROL, FULL COUNTERCLOCKWISE AND BAND SELECTOR POSITION AND RECEIVING IN RECEIVE POSITION.  $V_{AVC}$  VARIES WITH BAND SETTINGS.

TOP

BOTTOM

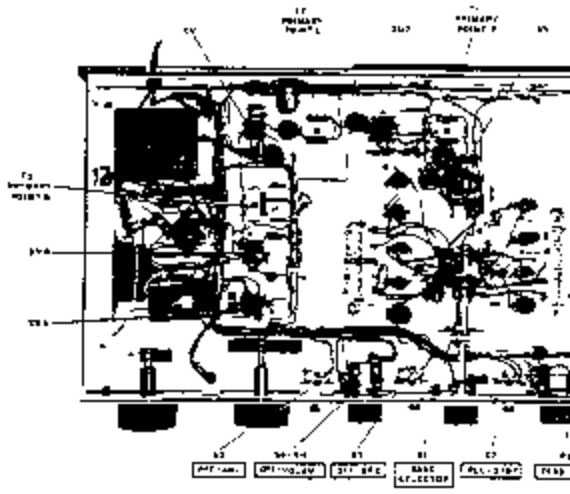
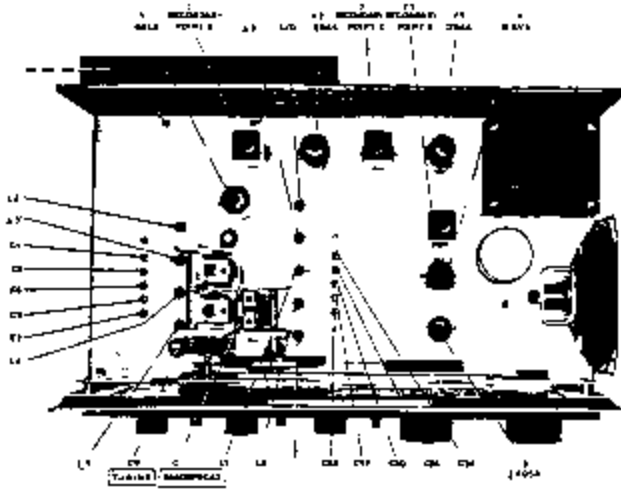

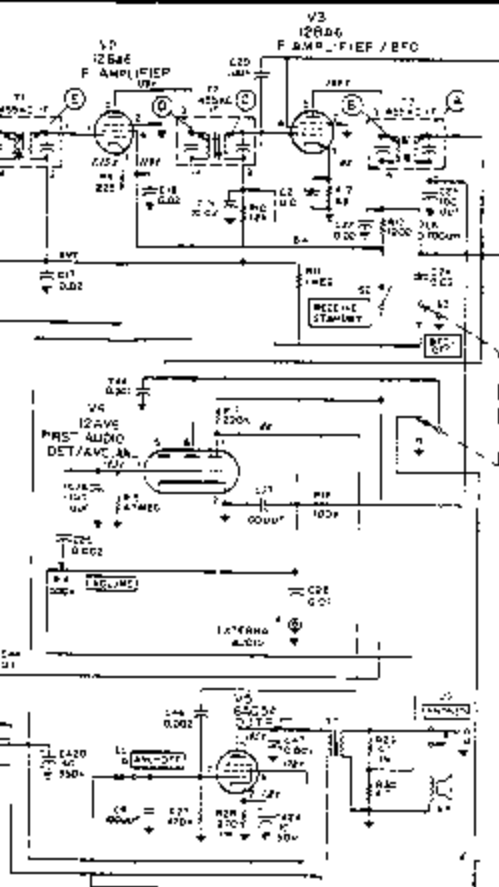

W STANBY POSITION  
 IN OFF POSITION  
 IN AM POSITION  
 AUTOMATIC MIXING

ALL VOLTAGES ARE TO BE MEASURED WITH  
 REFERENCE TO CHASSIS GROUND UNDER NO SIGNAL  
 CONDITIONS BY GAIN CONTROL FULLY CLOCKWISE OR  
 BY GAIN CONTROL FULLY COUNTERCLOCKWISE OR  
 AMO BFO IN OFF POSITION AND RECEIVE-STANBY  
 IN RECE-PC POSITION  
 \* SERIES WITH BAND SETTINGS

55-20823

## BOTTOM

