

R. M. HARTWELL M. D.

h
communications
OPERATING and SERVICE
INSTRUCTIONS

S-40B
S-40BU
RUN 3

the hallicrafters co.
MANUFACTURERS OF RADIO AND ELECTRONIC EQUIPMENT, CHICAGO 24, U. S. A.

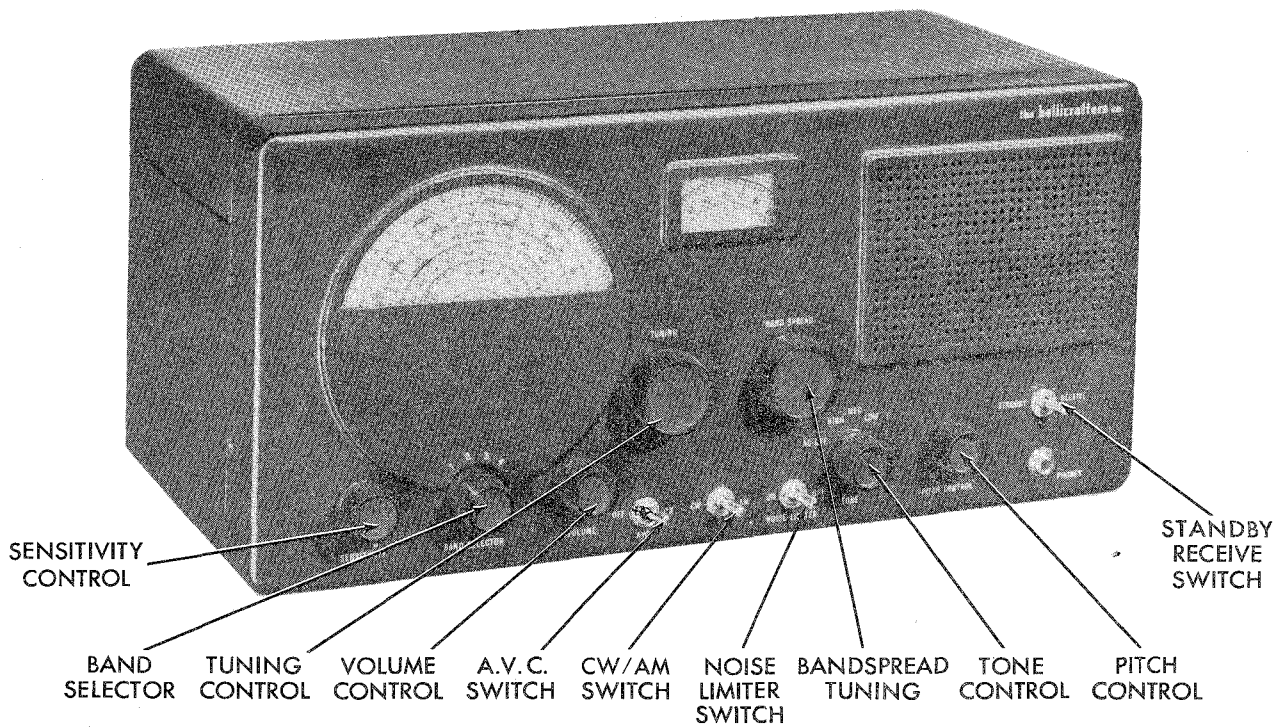

FIG. 1 MODELS S-40B & S-40BU

92X1140

DESCRIPTION

Models S-40B and S-40BU are sensitive superheterodyne communications receivers which provide reception of standard broadcast and foreign or domestic shortwave stations over four frequency ranges with continuous tuning from 540 KC (kilocycles) to 44 MC (megacycles). The receivers employ seven tubes plus rectifier and provide both AM and CW reception.

FREQUENCY COVERAGE

BAND	FREQUENCY RANGE
1	540 KC - 1680 KC
2	1680 KC - 5.4 MC
3	5.3 MC - 15.5 MC
4	15.5 MC - 44 MC

The four frequency ranges or bands are clearly indicated on the large main tuning dial. The locations of the amateur bands and foreign stations are indicated on the dial for convenient reference. Also on the main tuning dial is a special logging scale for use when logging frequencies of special interest.

The electrical BAND SPREAD control provides a vernier or fine tuning adjustment throughout the entire tuning range of the receiver.

Other special features included in the receiver are automatic volume control (AVC), automatic noise limiter and provision for headphone operation. The STANDBY/RECEIVE switch permits disabling of the receiver for standby periods, at the same time maintaining the tube heaters at operating temperature.

The receiver is housed in an attractive, well ventilated steel cabinet which has a length of 18-1/2 inches, a height of 8-1/2 inches and depth of 11 inches.

The S-40B is designed to operate from a 105-125 volt, 50-60 cycle AC power source. The S-40BU, a universal model of the S-40B, permits operation from 25-60 cycle AC sources at voltages ranging from 110 to 250 volts. The power consumption of each model is 75 watts.

INSTALLATION

UNPACKING Check all shipping tags and labels for instructions before removing or destroying them.

LOCATION - The receiver is equipped with rubber mounting feet for table top or shelf mounting. When locating the receiver, avoid excessively warm locations and recessed installations which prevent proper air circulation.

POWER SOURCE - The S-40B can be operated from a 105-125 volt, 50-60 cycle AC power outlet. The universal model, the S-40BU, is designed for operation from 115, 130, 150, 220 and 250 volt, 25-60 cycle AC sources. A selector switch, located on the power transformer, permits operation of the S-40BU at the line voltages shown. If in doubt as to the frequency and voltage rating of your power source, contact the local power company representative. Attempting to operate the receiver from sources of power not specified above may result in damage to the receiver.

CAUTION - When operating the universal model, it is essential that the selector switch setting on the power transformer correspond to the operating line voltage before connecting the receiver to the AC power source.

ANTENNA - A three terminal strip marked A1, A2 and G, is provided on the rear apron of the chassis for antenna connection. Very satisfactory results can be obtained throughout the tuning range of the receiver with a conventional single wire antenna installation (see Fig. 2). In some instances, a short length of wire strung about the room may suffice. However, for improved reception of the higher frequency bands, it is recommended that a doublet antenna installation be employed (see Fig. 3). For further information concerning antennas refer to "ARRL ANTENNA HANDBOOK".

SINGLE WIRE ANTENNA - Connect a single wire antenna 50 to 100 feet long (including lead-in) to terminal A1 on the antenna terminal strip. Connect the jumper between terminals A2 and G. Erect the antenna as high as possible and free of surrounding objects. A ground wire connected between terminal G and a suitable ground such as a cold water pipe or outside ground rod may improve reception.

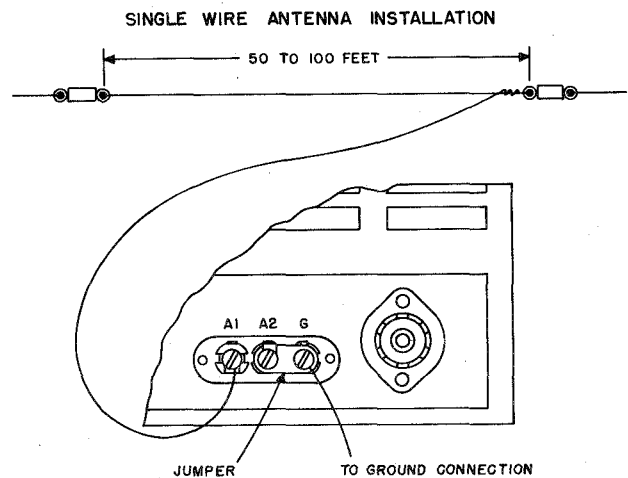

92A432

FIG. 2 SINGLE WIRE ANTENNA INSTALLATION

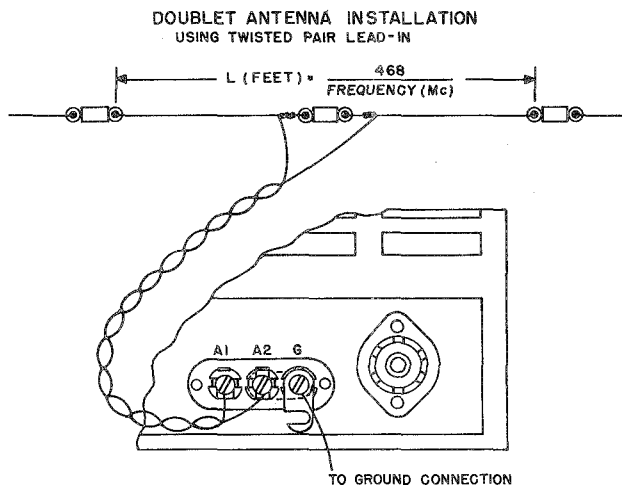

92A433-A

FIG. 3 DOUBLET ANTENNA INSTALLATION

DOUBLET ANTENNA - The overall length, in feet, of the doublet antenna may be determined by dividing 468 by the desired frequency in megacycles. A doublet antenna is somewhat directional broadside to its length and should be so oriented if maximum pickup from a given direction is to be expected.

When feeding the doublet antenna with twisted pair or a ribbon type transmission line, connect the transmission line to terminals A1 and A2 on the antenna terminal strip and disconnect the jumper between terminals A2 and G.

When using a coaxial transmission line, connect the inner conductor to terminal A1, the outer conductor to terminal A2 and place the jumper between terminals A2 and G.

OPERATION

Each control of this receiver performs a definite function that contributes to the outstanding reception capabilities. Full appreciation of the receiver is to be expected only after you have become familiar with each of the controls and the effect their operation has on the performance of the receiver. As an added feature for convenience, the control positions for standard broadcast reception are marked in red. The following use of the controls is recommended to obtain optimum performance from the receiver.

SENSITIVITY control This control is normally set fully clockwise for maximum sensitivity. In some rare instances, strong local signals may overload the receiver input. Distortion, caused by this condition, can be eliminated by reducing the receiver sensitivity slightly.

BAND SELECTOR switch This switch is used to select the desired band or frequency range. The frequencies covered by each position of the **BAND SELECTOR** are read directly from the main tuning dial scale which corresponds to the setting of the **BAND SELECTOR** switch.

VOLUME control This control is used to regulate audio volume. Turning the control clockwise increases volume.

AVC switch This switch, when set to the ON position, places the automatic volume control circuit in operation. The AVC circuit provides a constant audio output level over large variations in signal strength at the antenna. The AVC switch should be set at OFF for CW reception.

TUNING control This control should be set for the desired station frequency after setting the **BAND SELECTOR** switch. Frequencies on all bands are shown in megacycles.

IMPORTANT - The main tuning dial calibration is correct only when the **BAND SPREAD** dial pointer is set at 0.

AM/CW switch This switch, when set at CW, places the beat frequency oscillator (BFO) in operation making code signals audible. For AM reception, set the switch at AM.

BAND SPREAD control This control functions to electrically spread out the crowded amateur and short-wave bands. Band spread tuning is not necessary on the broadcast band.

Band spread tuning is accomplished as follows: (1) Set the band spread dial pointer at 0 (2) Position the **TUNING** control for the high frequency end of the amateur band or range of frequencies to be covered and (3) Tune through the amateur band or frequency range with the **BAND SPREAD** control.

NOTE: It is possible to log shortwave stations by recording the settings of the main tuning and band spread logging scales.

NOISE LIMITER switch This switch is normally set at OFF. Set the **NOISE LIMITER** switch at ON when severe electrical disturbances interfere with reception.

TONE control This control attenuates the high audio frequencies to the extent required by various receiving conditions. In addition, it is used to turn the receiver on and off. In the AC OFF position, the power to the receiver is disconnected. For CW reception, set the **TONE** control at LOW.

PITCH CONTROL This control is used to vary the pitch of the CW code signal when listening to amateur or commercial code stations and should be set for the tone most pleasing to the operator.

STANDBY/RECEIVE switch This switch, normally set at RECEIVE, is particularly useful to the "ham" as it provides a means of placing the receiver in an inoperative condition for standby periods, at the same time maintaining the tube heaters at operating temperature. The receiver is inoperative when the switch is set at STANDBY.

HEADPHONE OPERATION - The PHONES jack, located on the front panel, permits the use of standard headphones with the receiver. The speaker is automatically disconnected when the headphone plug is inserted in the PHONES jack.

SERVICE

GENERAL SPECIFICATIONS

Tubes Eight including one rectifier
 Speaker 5" PM
 Voice Coil Impedance 3.2 ohms
 Antenna Input For a 50-600 ohm line or
 single wire lead-in
 Intermediate Frequency 455 KC
 Power Supply . . Model S-40B: 105-125 V.
 50-60 cycle AC
 . . Model S-40BU: 105-250 V.
 25-60 cycle AC
 Power Consumption 75 watts

FREQUENCY COVERAGE

Band	Frequency Range	Reception
1	540 KC - 1680 KC	AM/CW
2	1680 KC - 5.4 MC	AM/CW
3	5.3 MC - 15.5 MC	AM/CW
4	15.5 MC - 44 MC	AM/CW

DIAL LAMP REPLACEMENT - Refer to Fig. 7 for the location of the dial lamps used in the receiver. To gain access to defective lamps, raise the hinged top cover of the cabinet. To make a dial lamp replacement, unclip the dial lamp socket from the mounting bracket. Replace defective lamps with 6-8 volt, 250 ma (blue bead) Mazda #44 pilot lamps.

RESTRINGING DIAL CORD - The dial drive system of the receiver consists of two separate string drives (1) main tuning dial drive and (2) band spread tuning dial drive. All restringing should be done with the main tuning and band spread gangs fully meshed.

MAIN TUNING DIAL DRIVE - Tie one end of an 16 inch length of 30 lb. test dial cord to the tension spring at position 1 on the main tuning capacitor drive pulley. Stretch the tension spring and follow the stringing procedure 1 through 4. At position 4, tie the cord securely to the spring.

BAND SPREAD DIAL DRIVE - Tie one end of a 24 inch length of 30 lb. test dial cord to the tension spring at position A on the band spread capacitor drive pulley. Stretch the tension spring and follow the stringing procedure A through G. At position G, tie the cord securely to the spring.

TUBE REPLACEMENT - The tube types and their relative location in the receiver are shown in Fig. 7. Raise the hinged top cover of the cabinet to gain access to all tubes. When installing a replacement tube, insert the center guide pin of the tube into the center hole of the tube socket, rotate the tube until the key on the guide pin drops into the notch in the socket hole and then push down until the base of the tube rests firmly on the socket. Handle all tubes with care as they are fragile and will not withstand mechanical abuse.

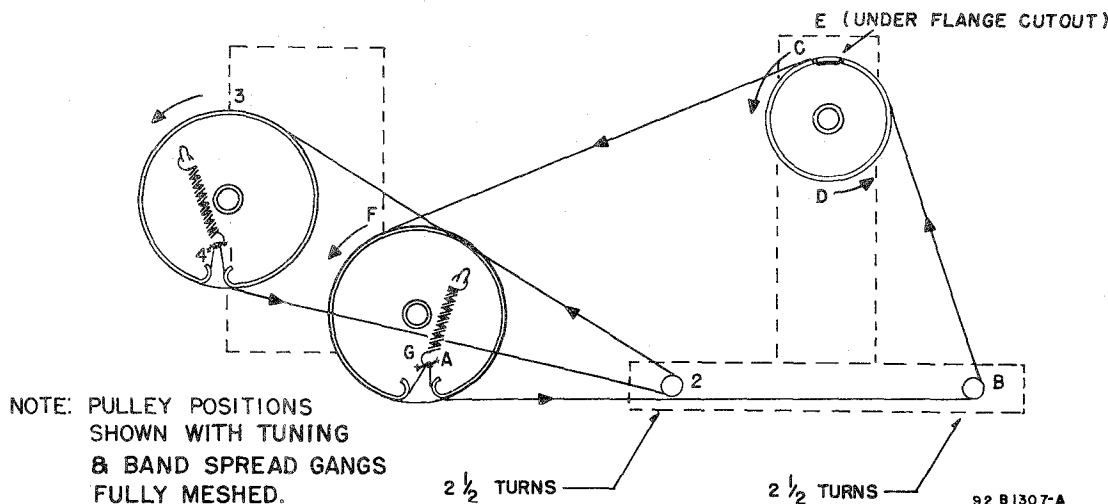

FIG. 4 DIAL CORD STRINGING DIAGRAM

SERVICE OR OPERATING QUESTIONS - For further details regarding operation or servicing of the receiver, contact your dealer. Make no shipments directly to the factory as the factory does not accept the responsibility for unauthorized shipments. Factory type service is available at any HALLICRAFTERS AUTHORIZED SERVICE CENTER. For the location of the SERVICE CENTER nearest you; consult your dealer, telephone directory or look for the sign shown at the right.

The Hallicrafters Co. reserves the privilege of making revisions in current production of equipment and assumes no obligation to incorporate these revisions in earlier models.



ALIGNMENT PROCEDURE

EQUIPMENT REQUIRED

1. Signal generator, with amplitude modulated output, covering 455 KC to 36 MC. Use a modulated signal generator output for every step except step 2.
2. Output meter. Connect the meter across the speaker voice coil terminals.
3. Standard RMA dummy antenna consisting of a 200 mmf. capacitor in series with a 20 microhenry choke which is shunted by a 400 mmf. capacitor in series with a 400 ohm carbon resistor.
4. Alignment tool made of polystyrene or other similar material.

It is necessary to remove the receiver chassis from the cabinet to make the I-F alignment. The chassis is held in the cabinet by three screws along the bottom edge of both the front panel and rear of the cabinet and by two screws on either side of the front panel.

RF alignment should be made with the chassis in the cabinet. Holes in the bottom of the cabinet provide access to all RF adjustments.

Before starting alignment, set the VOLUME, SENSITIVITY and BAND SPREAD controls fully clockwise, AVC and NOISE LIMITER switches at OFF, CW/AM switch at AM and the TONE switch at HIGH. Refer to Figs. 5 and 6 for the location of all adjustments.

ALIGNMENT CHART

STEP	SIGNAL GENERATOR CONNECTION	SIGNAL GEN. FREQUENCY	BAND SELECTOR SETTING	MAIN TUNING DIAL SETTING	ADJUST	REMARKS
1	Connect the high side of the generator to the stator plates of the center section of the tuning gang. Connect the ground side of the generator to the chassis.	455 KC	1	1000 KC	S1, S2, S3, S4, S5, S6	Adjust for maximum audio output at the speaker voice coil. Use only enough signal generator output to obtain a 50 milliwatt reading on the output meter.
2*	Same as Step 1	455 KC (No Modulation)	1	1000 KC	S7	Set the CW/AM switch at CW. Remove the PITCH CONTROL knob and adjust S7 for a zero beat. Replace the knob with the dot in top center position.
3	Connect the high side of the generator to A1 on the antenna terminal strip through a standard RMA dummy antenna. Place the jumper between A2 and G. Connect the ground side of the generator to the chassis.	36 MC	4	36 MC	A, B, C	Maximum output as in Step 1.
		18 MC	4	18 MC	S8, S9, S10	
4	Same as Step 3	14 MC	3	14 MC	D, E, F	Maximum output as in Step 1.
		10 MC	3	10 MC	S11, S12, S13	
5	Same as Step 3	5 MC	2	5 MC	G, H, I	Maximum output as in Step 1.
		1.8 MC	2	1.8 MC	S14	
6	Same as Step 3	1500 KC	1	1.5 MC	J, K, L	Maximum output as in Step 1.
		600 KC	1	.6 MC	M	

* Reset the CW/AM switch at AM when Step 2 is completed.

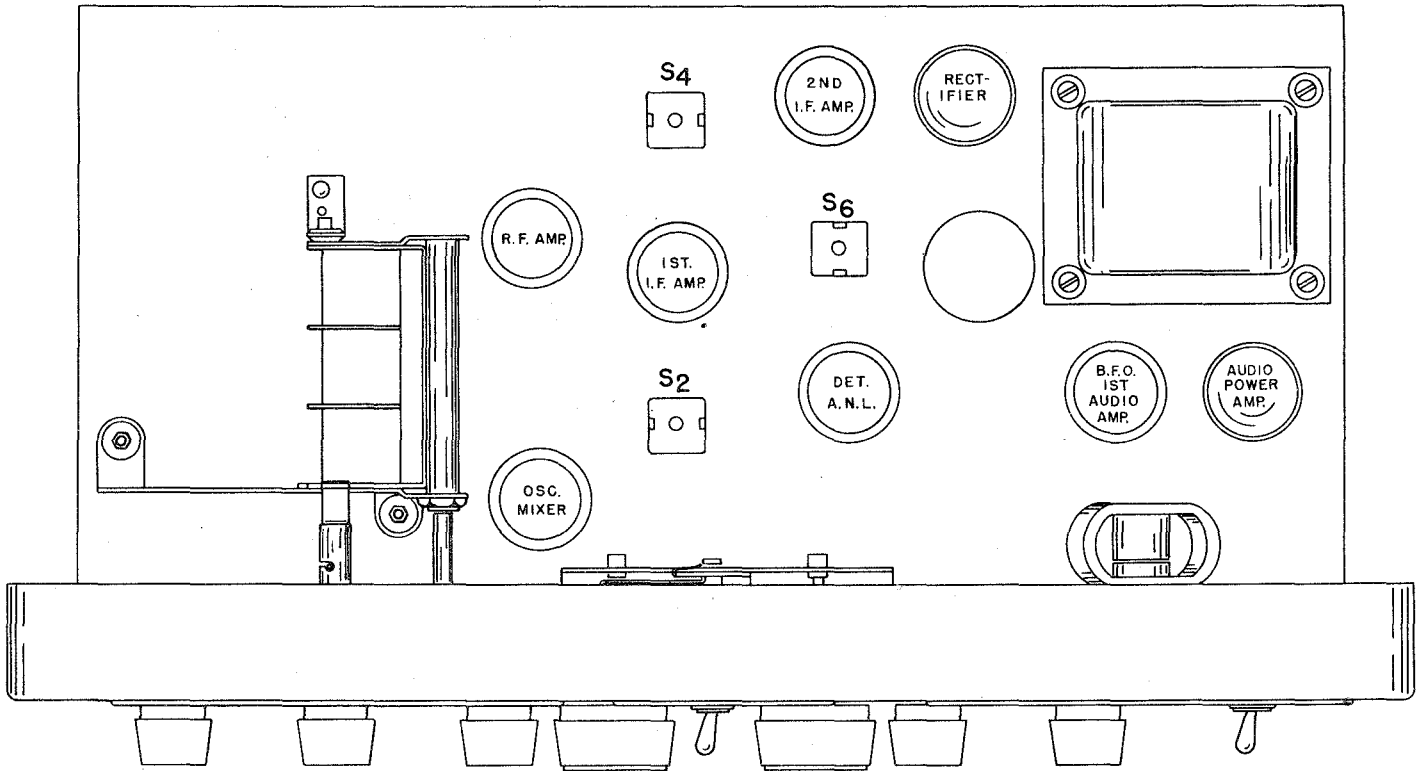

92D1132

FIG. 5 TOP VIEW - LOCATION OF ALIGNMENT ADJUSTMENTS

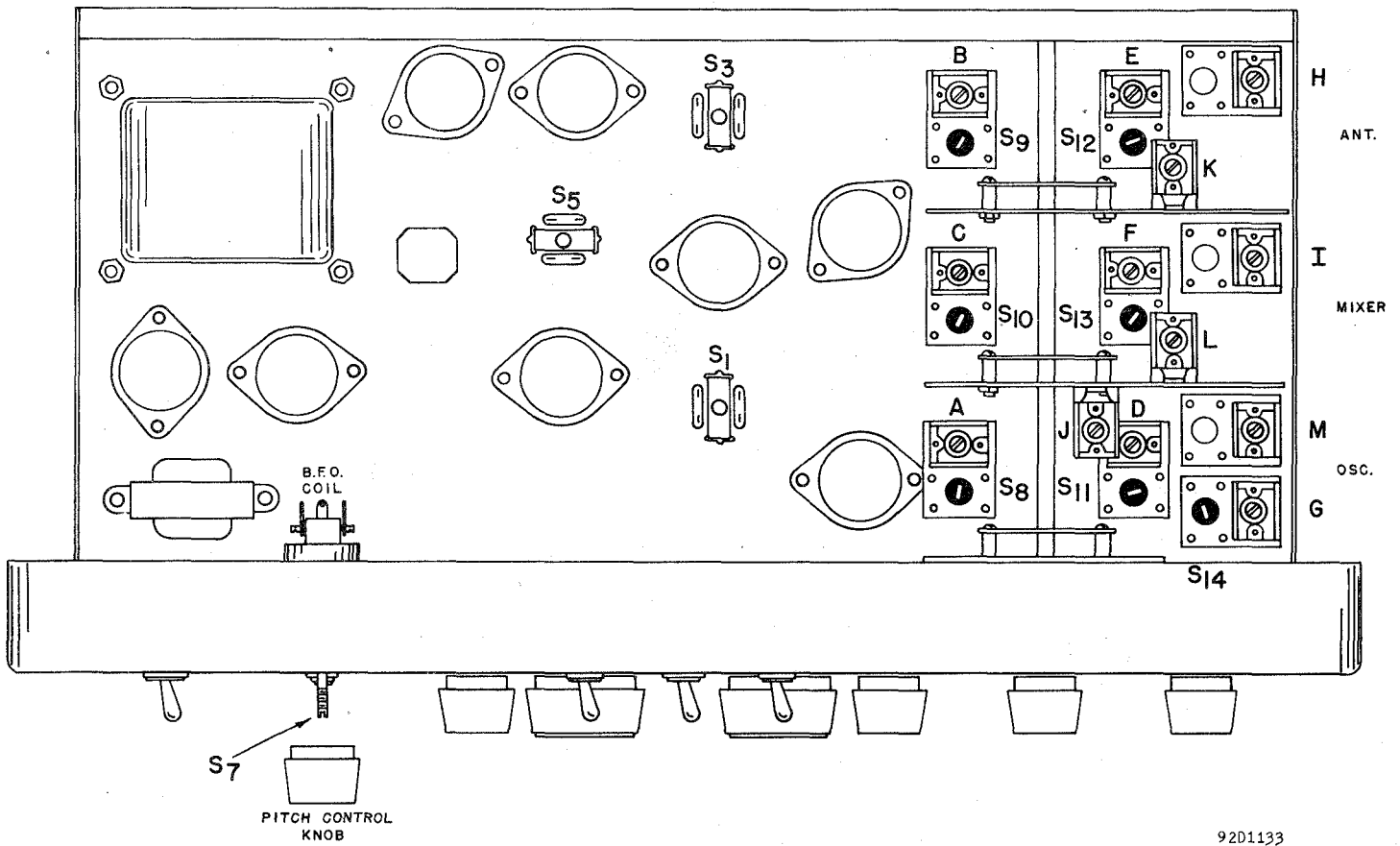

92D1133

FIG. 6 BOTTOM VIEW - LOCATION OF ALIGNMENT ADJUSTMENTS

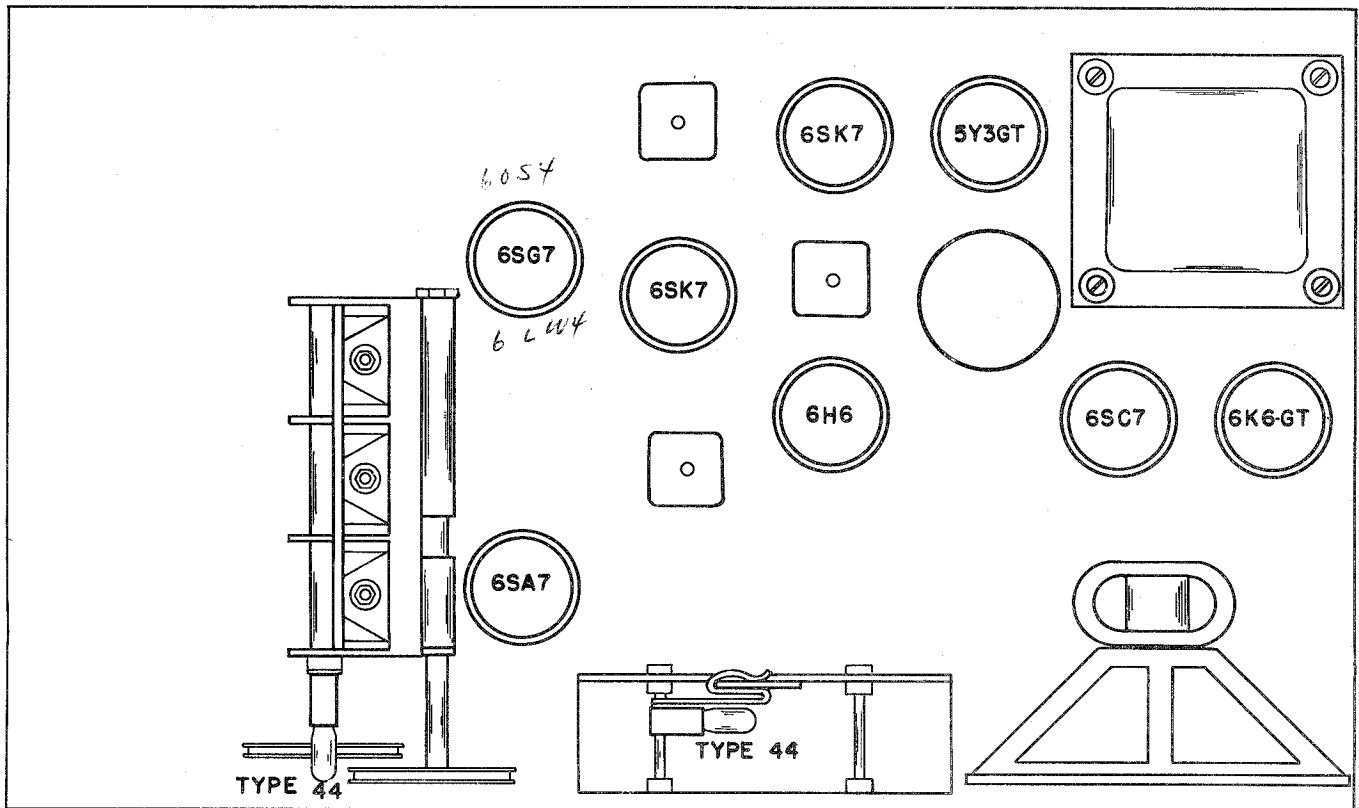

FIG. 7 TOP VIEW - LOCATION OF TUBES AND DIAL LAMPS

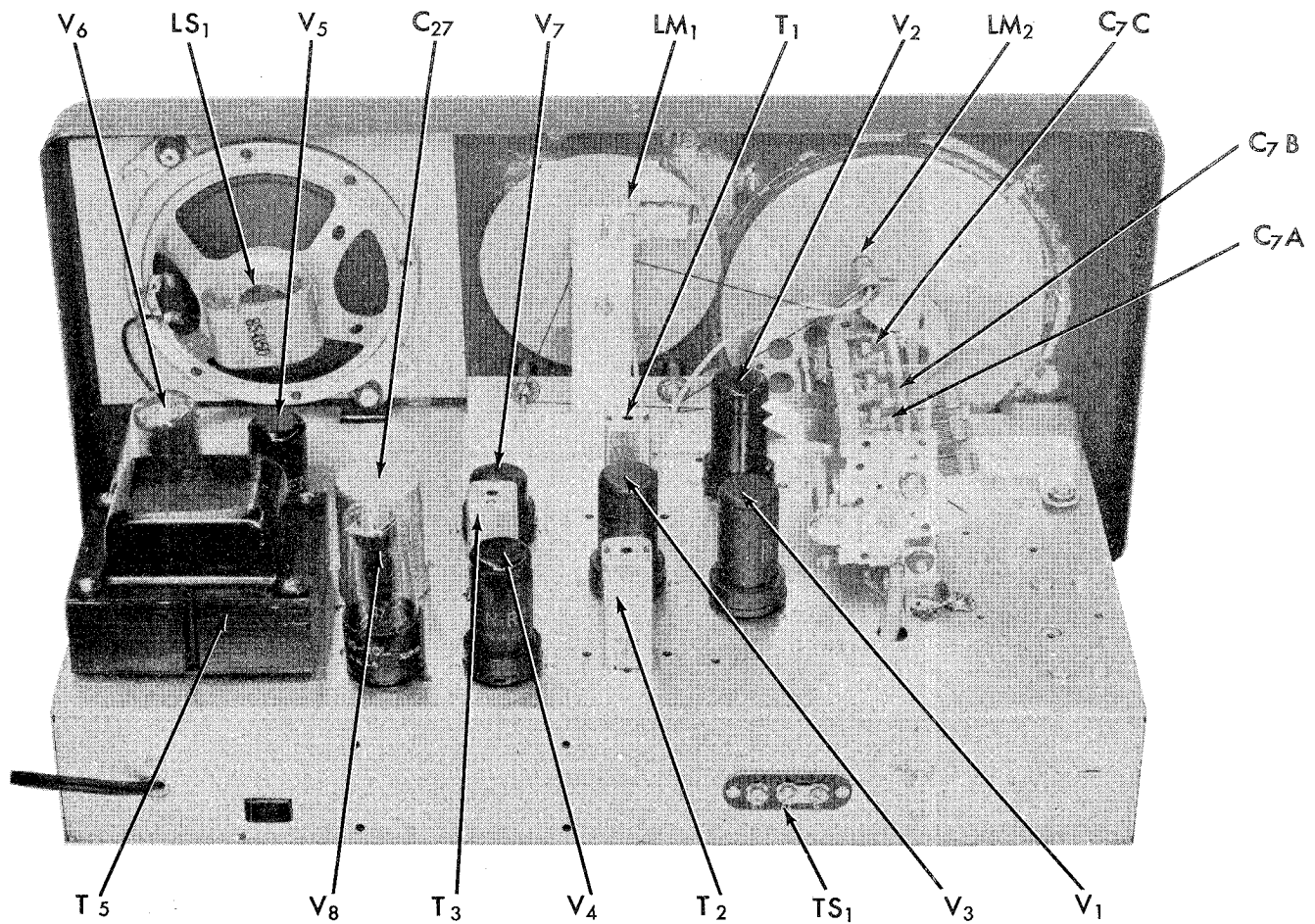

FIG. 8 TOP VIEW - COMPONENT LOCATION

92X1126-A

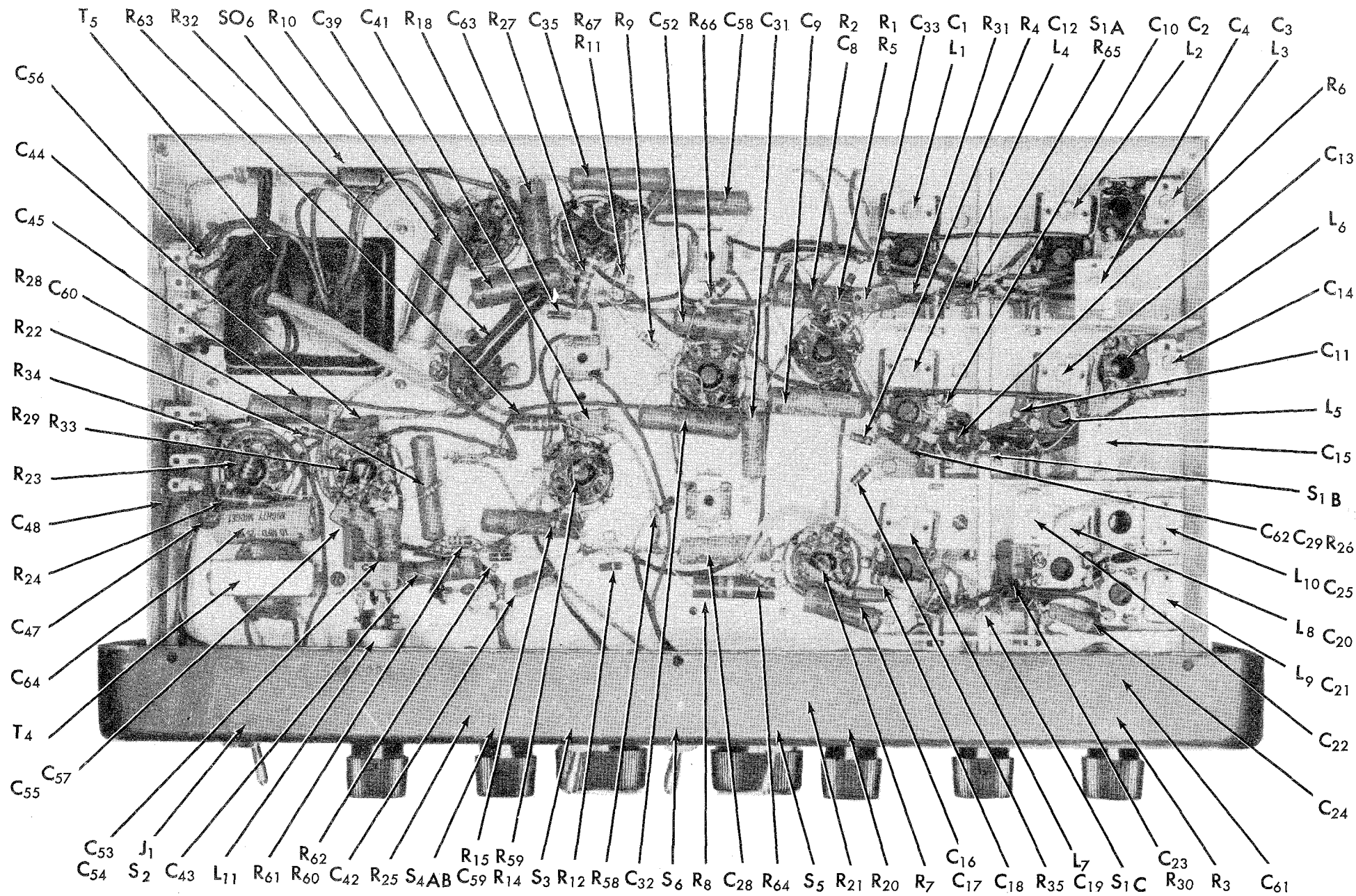
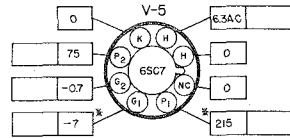
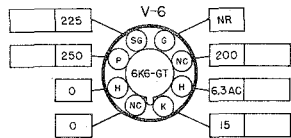
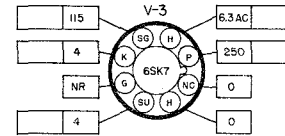
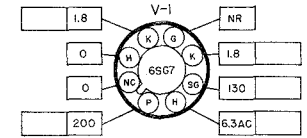
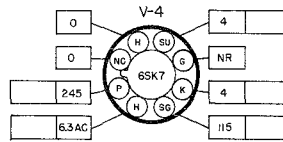
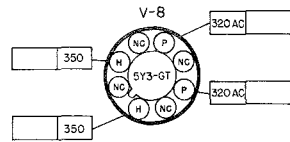
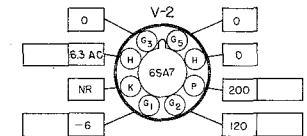
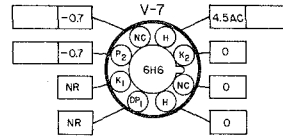

FIG. 9 BOTTOM VIEW - COMPONENT LOCATION

92X1127-A



*CW/AM SWITCH IN CW POSITION.



NOTES--

1. SOCKET VIEWS ARE BOTTOM VIEWS.
2. ALL VOLTAGES ARE MEASURED BETWEEN TUBE SOCKET TERMINALS AND CHASSIS WITH ZERO SIGNAL INPUT.
3. LINE VOLTAGE 117 V. AC.
4. ALL VOLTAGES ARE DC UNLESS OTHERWISE SPECIFIED.
5. DC VOLTAGES SHOWN WERE MEASURED WITH A VACUUM TUBE VOLTMETER.
6. "NC"=NO CONNECTION (VOLTAGE SHOWN FOR THIS TERMINAL ONLY WHEN TERMINAL IS USED AS A TIE LUG)
7. "NR"=NOT READABLE (READING GENERALLY MEANINGLESS)
8. □ SPACE PROVIDED FOR SERVICE METER READINGS.

FRONT APRON
BOTTOM VIEW OF CHASSIS

FIG. 10 TUBE SOCKET VOLTAGE CHART

SERVICE PARTS LIST

Schematic Symbol	Description	Hallicrafters Part Number	Schematic Symbol	Description	Hallicrafters Part Number
CAPACITORS			COILS AND TRANSFORMERS (Cont.)		
C-1,2,3,12,13,14,19,20,21	Trimmers; part of coils L-1,2,3,4,5,6,7,8 and 9 respectively	- - - - -	L-6	Coil, RF; bands 1 and 2	51B1240
C-4,15,22	Trimmer, 1.5-15 mmf.	44A191	L-7	Coil, oscillator; band 4	51B791
C-7A,B&C	Tuning capacitor, 3 section	48C240	L-8	Coil, oscillator; band 3	51B913
C-8,32,35,58,59,60	.05 mfd. 200 V., tubular	46AU503J	L-9	Coil, oscillator; band 2	51B789
C-9,28	.05 mfd. 600 V., tubular	46AY503J	L-10	Coil, oscillator; band 1	51B912
C-10	22 mmf. 500 V., ceramic	47X21UK220M	L-11	Coil, BFO	54B044
C-11	15 mmf. 500 V., ceramic	47X21UK150M	T-1,2	Transformer, 1st and 2nd IF	50C243
C-16	390 mmf. 500 V., mica	47X20B391K	T-3	Transformer, IF; detector stage	50C242
C-17,53	.01 mfd. 600 V., tubular	46AY103J	T-4	Transformer, audio output	55B093
C-18	68 mmf. 500 V., ceramic	47X25UK680K	T-5	Transformer, power; model S-40B	52A209
C-23	3000 mmf. 500 V., mica	47X30C302K	T-5	Transformer, power; model S-40BU	52C210
C-24	1500 mmf. 500 V., mica	47X30C152J	SWITCHES		
C-25	Padder; part of coil L-10	- - - - -	S-1A	Switch wafer, BAND SELECTOR; antenna stage	⊙ 60B389 or * 62B070
C-27A,B&C	30-10-10 mfd. 450 V., electrolytic	45A062	S-1B	Switch wafer, BAND SELECTOR; RF stage	⊙ 62B039 or * 62B072
C-29,33	220 mmf. 500 V., mica	47X20B221K	S-1C	Switch wafer, BAND SELECTOR; oscillator stage	⊙ 62B044 or * 62B071
C-31,43	.02 mfd. 200 V., tubular	46AU203J	S-2,3,5,6,	Switch, toggle (spst); STANDBY/RECEIVE, NOISE LIMITER, AVC and CW/AM	60A138
C-38	2 mmf., twisted wire assembly	- - - - -	S-4	Switch, PWR-TONE	60A225
C-39	.1 mfd. 600 V., tubular	46AY104J		Shaft and index plate, BAND SELECTOR	⊙ 60B392 or * 60B485
C-41,42	47 mmf. 500 V., mica	47X20B470M	PLUGS AND SOCKETS		
C-44,55	270 mmf. 500 V., mica	47X20B271K	J-1	Jack, PHONES	36A002
C-45,48,52,63	.02 mfd. 600 V., tubular	46AY203J	PL-1	Line cord and plug	87B1573
C-47	.002 mfd. 1000 V., tubular	46A104		Socket, dial lamp; main tuning dial	86A070
C-54	470 mmf. 500 V., mica	47X20B471J		Socket, dial lamp; band spread dial	86B049
C-56	.01 mfd. 600 V., molded tubular	46AC103J		Socket, octal tube	6A250
C-57	1000 mmf. 500 V., mica	47X25B102M	TUBES AND DIAL LAMPS		
C-61	.25 mfd. 200 V., tubular	46AT254J	V-1	6SG7: RF amplifier	90X6AG7
C-62	2.2 mmf. 500 V., bakelite	47A160-4	V-2	6SA7: converter	90X6SA7
C-64	10 mfd. 25 V., electrolytic	45A121	V-3,4	6SK7: 1st and 2nd IF amplifiers	90X6SK7
RESISTORS			V-5	6SC7: BFO and audio amplifier	90X6SC7
R-1,62	1 megohm 1/2 watt, carbon	23X20X105M	V-6	6K6GT: audio output	90X6K6GT
R-2	120 ohms 1/2 watt, carbon	23X20X121K	V-7	6H6: ANL, AVC and detector	90X6H6
R-3	10,000 ohms, SENSITIVITY control	25B590	V-8	5Y3GT: rectifier	90X5Y3GT
R-4,31	22 ohms 1/2 watt, carbon	23X20X220M	LM-1,2	Lamp, dial; Mazda #44	39A003
R-5	39,000 ohms 1 watt, carbon	23X30X393K	MISCELLANEOUS		
R-6,26	6800 ohms 1 watt, carbon	23X30X682K	Cabinet		66D359
R-7	18,000 ohms 1/2 watt, carbon	23X20X183K	Cabinet top cover		66D616
R-8	10,000 ohms 2 watts, carbon	23X40X103K	Cabinet front panel		68D157
R-9	470 ohms 1/2 watt, carbon	23X20X471K	Dial cord, 40 inch		38A001
R-10	12,000 ohms 4 watts, carbon	23X65CE123K	Dial, band spread		83B372
R-11,18,65	1000 ohms 1/2 watt, carbon	23X20X102K	Dial, main tuning		83C240
R-12,59	2.2 megohms 1/2 watt, carbon	23X20X225M	Foot, mounting; rubber		16A007
R-14	47,000 ohms 1/2 watt, carbon	23X20X473M	Glass, band spread dial		22A307
R-15,29,58	100,000 ohms 1/2 watt, carbon	23X20X104M	Glass, main tuning dial		22B199
R-20	500,000 ohms, VOLUME control	25A534	Iron core, RF		77A068
R-21	150 ohms 1/2 watt, carbon	23X20X151M	Knob, BAND SELECTOR		15A266
R-22	270,000 ohms 1/2 watt, carbon	23X20X274K	Knob, PITCH CONTROL		15A058
R-23,61	470,000 ohms 1/2 watt, carbon	23X20X474M	Knob, SENSITIVITY, VOLUME and TONE		15A049
R-24	680 ohms 1 watt, carbon	23X20X681K	Knob, TUNING and BAND SPREAD		15A048
R-25	15,000 ohms 1 watt, carbon	23X30X153M	Lock, line cord		76A397
R-27,66	47,000 ohms 1 watt, carbon	23X30X473K	Speaker, 5" PM		85B050
R-28	22,000 ohms 1/2 watt, carbon	23X20X223M	Spring, dial cord		75A012
R-30,68	10 ohms 1/4 watt, carbon	23X10X100M	Spring, retainer; band spread and main tuning drive shafts		75A062
R-32	1500 ohms 10 watts, WW	24BG152E	Terminal strip, antenna		88A032
R-33	15 megohms 1/4 watt, carbon	23X10X156M			
R-34	10,000 ohms 1/2 watt, carbon	23X20X103M			
R-35	27 ohms 1/4 watt, carbon	23X10X270K			
R-60,67	330,000 ohms 1/2 watt, carbon	23X20X334K			
R-63	6.8 ohms 1 watt, carbon	23X30X068K			
R-64	330 ohms 1/2 watt, carbon	23X20X331K			
COILS AND TRANSFORMERS					
L-1	Coil, antenna; band 4	51B783			
L-2	Coil, antenna; band 3	51B782			
L-3	Coil, antenna; bands 1 and 2	51B1241			
L-4	Coil, RF; band 4	51B787			
L-5	Coil, RF; band 3	51B786			

⊙ Switch wafers 60B389, 62B039 and 62B044 can be used only in conjunction with shaft and index plate 60B392.
 * Switch wafers 62B070, 62B072 and 62B071 can be used only in conjunction with shaft and index plate 60B485.

Changed to 6DS4/6CW4

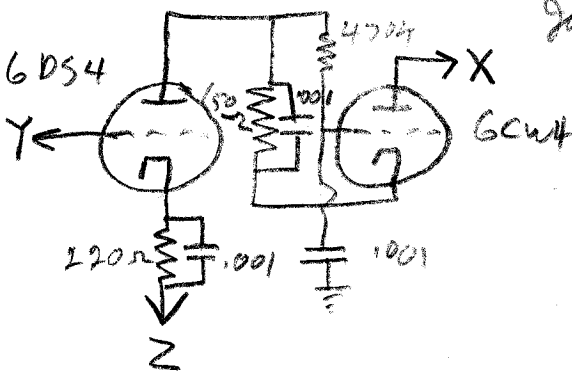
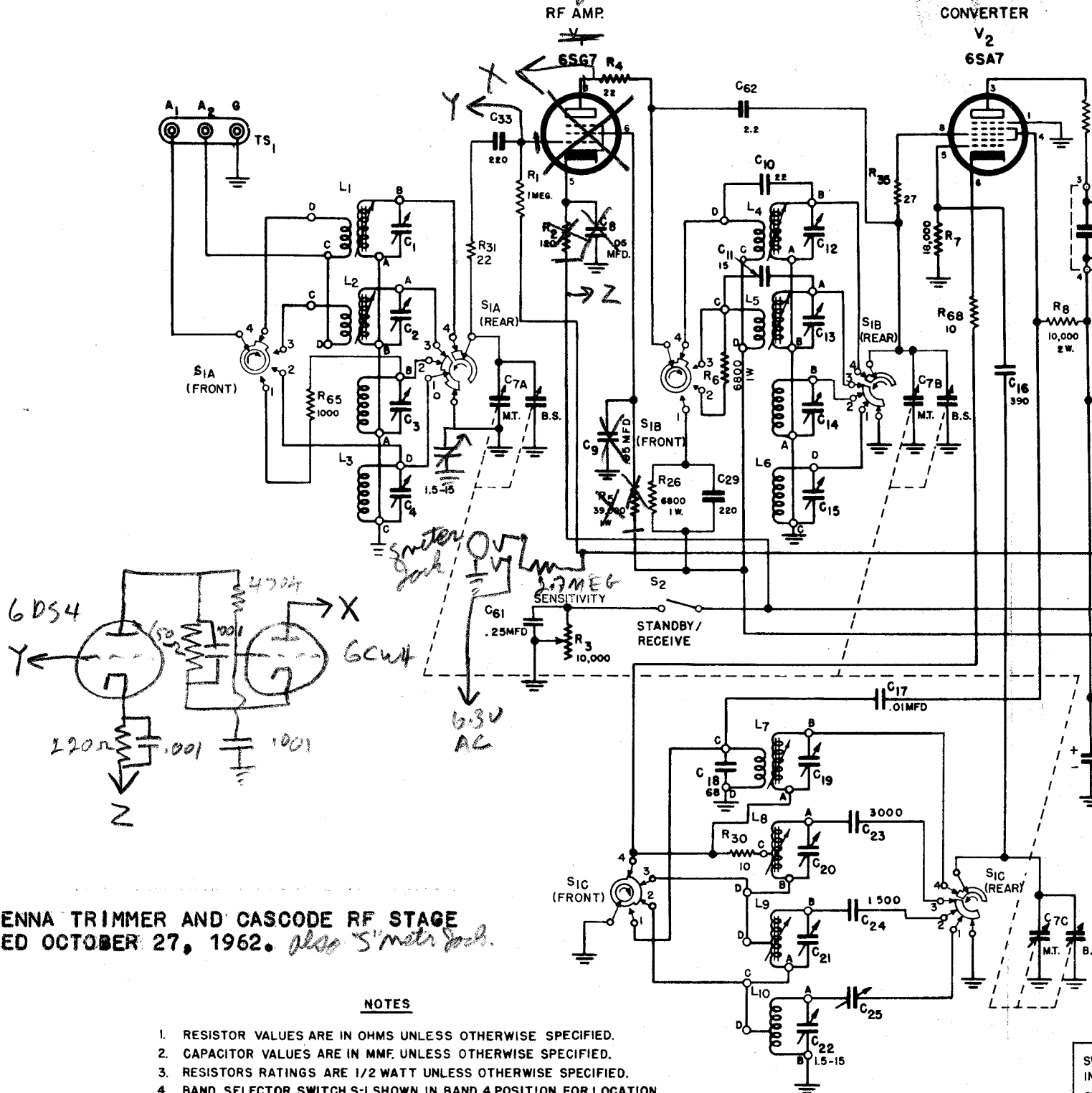

ANTENNA TRIMMER AND CASCODE RF STAGE
 ADDED OCTOBER 27, 1962. *also 5' meter Jack.*

NOTES

1. RESISTOR VALUES ARE IN OHMS UNLESS OTHERWISE SPECIFIED.
2. CAPACITOR VALUES ARE IN MMF UNLESS OTHERWISE SPECIFIED.
3. RESISTORS RATINGS ARE 1/2 WATT UNLESS OTHERWISE SPECIFIED.
4. BAND SELECTOR SWITCH S-1 SHOWN IN BAND 4 POSITION. FOR LOCATION OF SWITCH SECTIONS, SEE FIG. 9.

VALUES AND TOLERANCES SHOWN ARE NOMINAL AND VARIATIONS MAY BE FOUND. IT IS RECOMMENDED THAT THE VALUE OF ANY REPLACEMENT CORRESPOND TO THE NOMINAL VALUE OF THE PART BEING REPLACED.

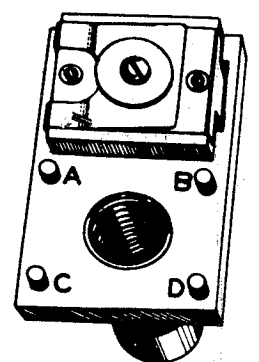

REPRESENTS COILS L₁ TO L₁₀

Changed to 6DS4/6DS4

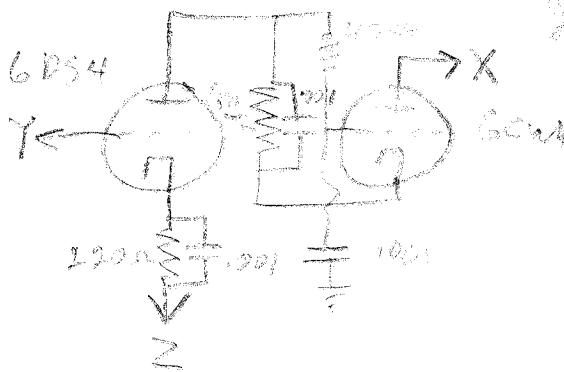
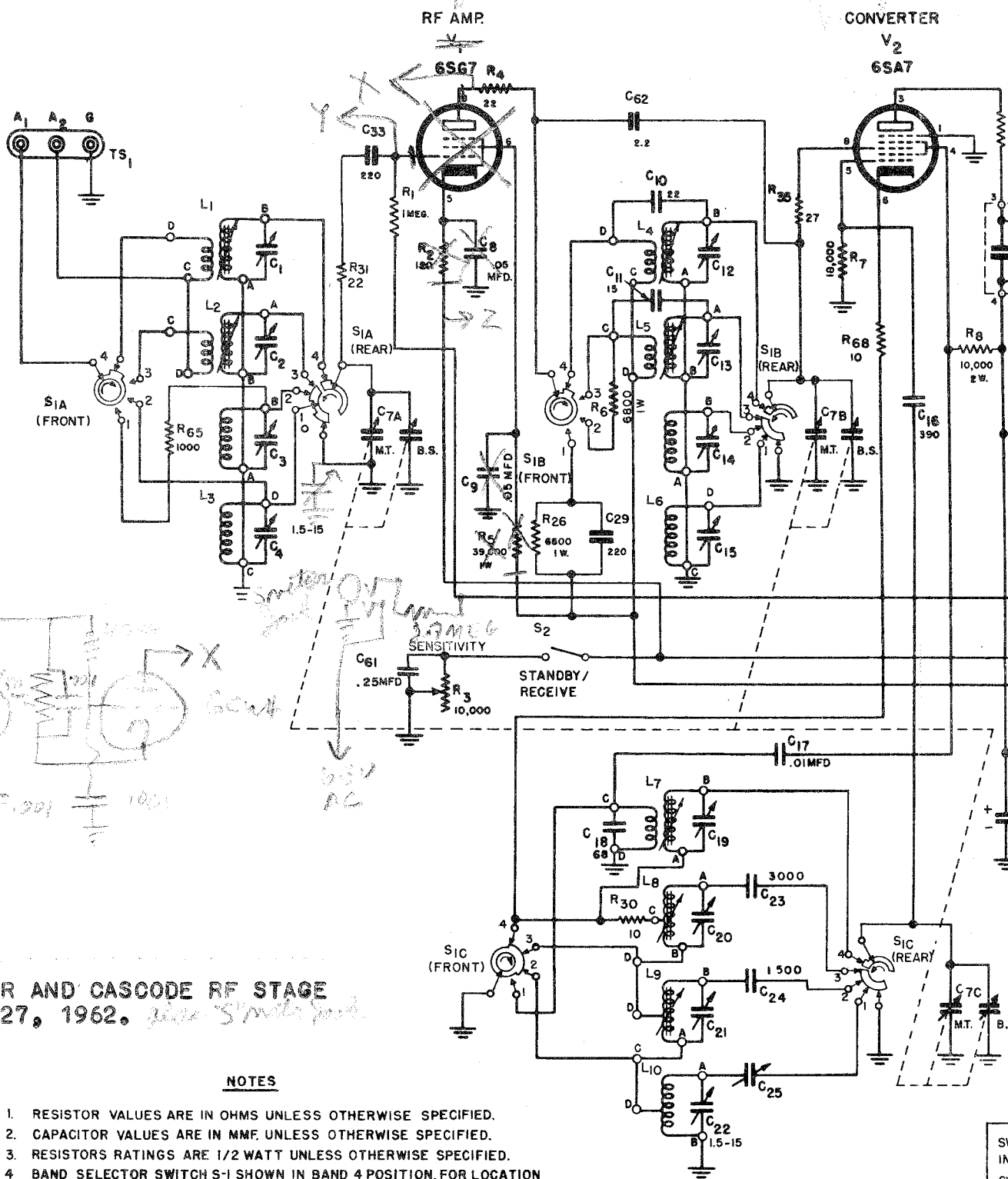

ANTENNA TRIMMER AND CASCODE RF STAGE
 ADDED OCTOBER 27, 1962. *same Smith Chart*

NOTES

1. RESISTOR VALUES ARE IN OHMS UNLESS OTHERWISE SPECIFIED.
2. CAPACITOR VALUES ARE IN MMF. UNLESS OTHERWISE SPECIFIED.
3. RESISTOR RATINGS ARE 1/2 WATT UNLESS OTHERWISE SPECIFIED.
4. BAND SELECTOR SWITCH S-1 SHOWN IN BAND 4 POSITION. FOR LOCATION OF SWITCH SECTIONS, SEE FIG. 9.

VALUES AND TOLERANCES SHOWN ARE NOMINAL AND VARIATIONS MAY BE FOUND. IT IS RECOMMENDED THAT THE VALUE OF ANY REPLACEMENT CORRESPOND TO THE NOMINAL VALUE OF THE PART BEING REPLACED.

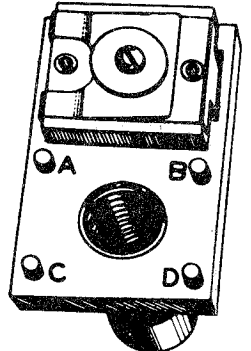

REPRESENTS COILS L₁ TO L₁₀

SW
 IN
 SW
 PC

MODELS S-40B S-40BU

RUN 3

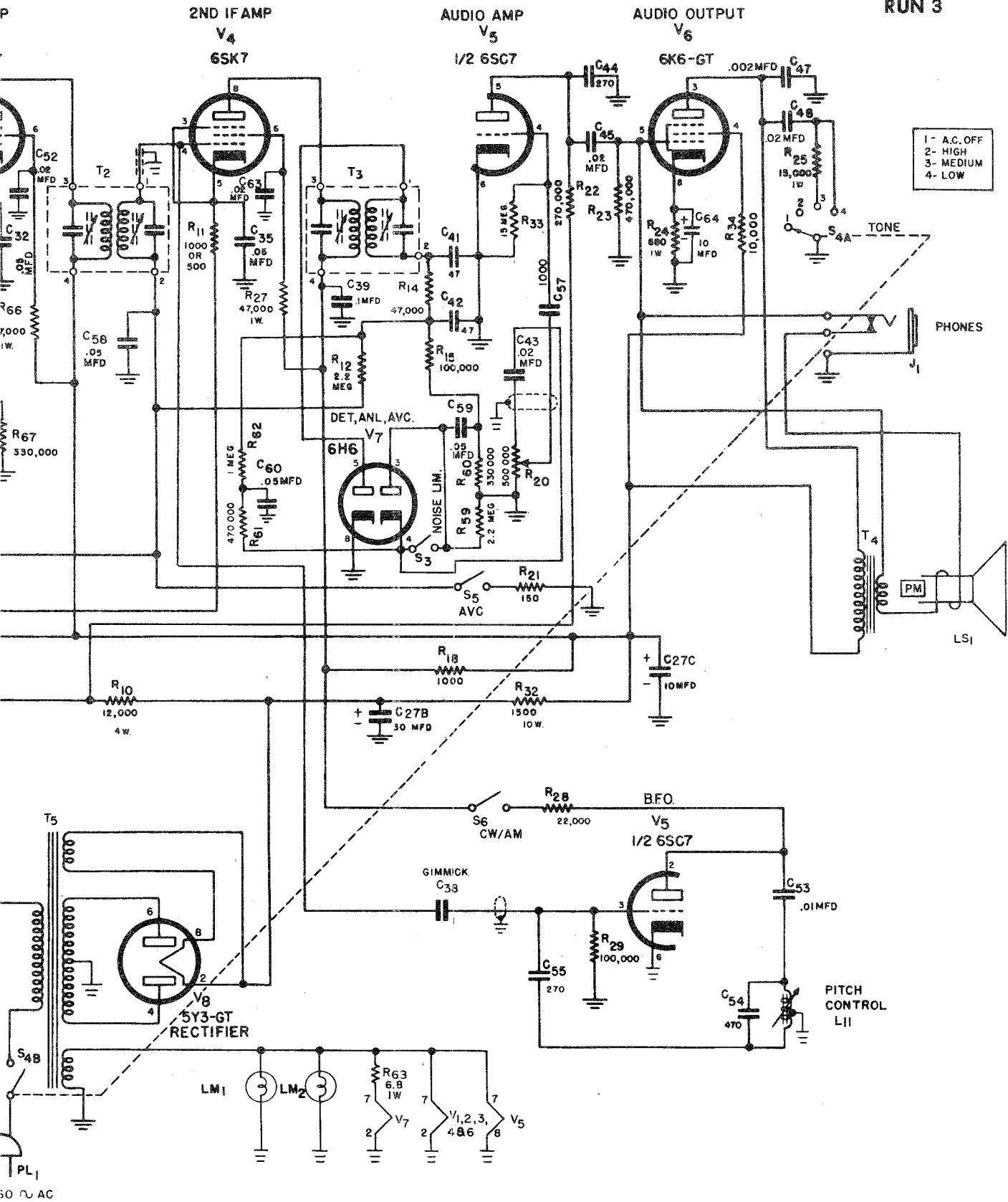

LAST R SYMBOL R-68
LAST C SYMBOL C-64

890349-D

FIG. 11 SCHEMATIC DIAGRAM

ANTENNA INSTALLATION NOTE

To facilitate convenient installation, a 15 foot insulated antenna wire has been included with your receiver. The entire length of this antenna should be uncoiled and run about the room in any convenient manner. One end of the antenna wire should be connected to terminal "A1" on the antenna terminal strip located on the rear of the receiver. The jumper provided on the strip should be connected between terminals "A2" and "G". In some locations, a lead connected between terminal "G" and a cold water pipe or other good ground may improve reception.

Refer to your "OPERATING AND SERVICE INSTRUCTION" book for further antenna information. The antenna wire provided may later be used as a lead-in for certain types of outdoor antennas.

ERRATA SHEET NO. 94X821

INSTRUCTIONS FOR USING ANTENNA TRIMMER

IF S METER IS ATTACHED, TUNE TRIMMER FOR THE HIGHEST READING ON THE METER. IF THERE IS NO S METER IN USE, ADJUST THE TRIMMER FOR THE LOUDEST SIGNAL WITH THE AVC TURNED OFF.
NOTE: ON THE LAST BAND (4) THE TRIMMER SETTING WILL AFFECT THE TUNING A SLIGHT AMOUNT.

R. M. HARTWELL M. D.

Warranty

"The Hallicrafter's Company warrants each new radio product manufactured by it to be free from defective material and workmanship and agrees to remedy any such defect or to furnish a new part in exchange for any part of any unit of its manufacture which under normal installation, use and service discloses such defect, provided the unit is delivered by the owner to our authorized radio dealer, wholesaler, from whom purchased, or, authorized service center, intact, for examination, with all transportation charges prepaid within ninety days from the date of sale to original purchaser and provided that such examination discloses in our judgment that it is thus defective.

This warranty does not extend to any of our radio products which have been subjected to misuse, neglect, accident, incorrect wiring not our own, improper installation, or to use in violation of instructions furnished by us, nor extend to units which have been repaired or altered outside of our factory or authorized service center, nor to cases where the serial number thereof has been removed, defaced or changed, nor to accessories used therewith not of our own manufacture.

Any part of a unit approved for remedy or exchange hereunder will be remedied or exchanged by the authorized radio dealer or wholesaler without charge to the owner.

This warranty is in lieu of all other warranties expressed or implied and no representative or person is authorized to assume for us any other liability in connection with the sale of our radio products."

Form No. 94X622

the Hallicrafters co.