

MODEL S-72

GENERAL

- Tubes Eight plus selenium rectifier
 - Speaker 5-inch PM
 - Speaker V.C. Impedance 3.2 ohms (100 ohm headset tap)
 - Headset Output. For 500 to 5000-ohm phones
 - Antenna Loop for band 1
Whip for bands 2, 3 and 4
Provisions for connection to an external antenna
 - Tuning Manual
- | Tuning Range. | Band Selector Position | Frequency Range |
|-----------------------|------------------------|------------------|
| | 1. | 550 kc - 1600 kc |
| | 2. | 1500 kc - 4.4 mc |
| | 3. | 4.5 mc - 11.5 mc |
| | 4. | 11 mc - 30 mc |
- Intermediate Frequency. 455 kc.
 - Power Supply. 105-125 V. DC/60 cycles AC or Battery Pack
 - Power Consumption 25 Watts

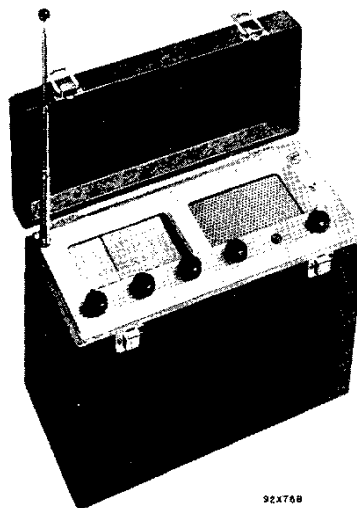

92X76B

drive following the lettered sequence "A" through "E" and at position "E" stretch the tension spring and tie the cord securely. In cases where the set screw on the band spread pulley has been loosened, set the general coverage dial to the frequency of a signal generator or local short wave station and tune in the signal with the band spread drive shaft. Turn the pulley counter clockwise to the stop, tighten the set screw and attach the band spread pointer and index it at 100 on the band spread dial scale.

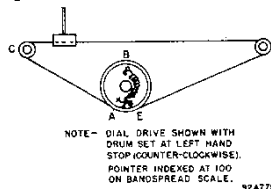

Figure 2. Dial cable stringing procedure, band spread

RESTRINGING DIAL CORD

GENERAL COVERAGE DIAL

To restring the general coverage tuning dial drive, cut a 32-inch length of 30 lb. test dial cord and tie one end to the tie-point "1" shown in Fig. 1. Follow the number sequence "1" through "12" and at position "12" stretch the tension spring and tie the cord securely. Note that the string is wrapped around the drive shaft three and a fraction times for proper traction. Close the gang capacitor and attach the pointer so that it is aligned with the index marks on the left side of the dial scales.

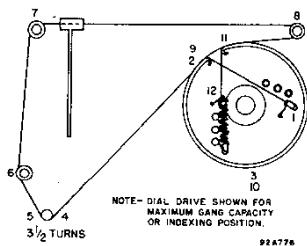

Figure 1. Dial cable stringing procedure, general coverage

BATTERY REPLACEMENT

A strip of canvas webbing and a hold down screw are used to keep the battery in the cabinet. To replace the battery, disconnect the battery plug and loosen the hold down screw. Refer to Fig. 3.

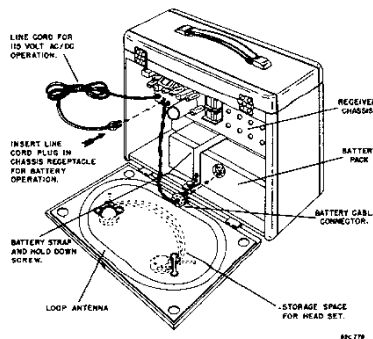

Figure 3. Battery compartment

BAND SPREAD DIAL

To restring the band spread tuning dial drive, cut a 24-inch length of 30 lb. test dial cord and tie one end to the tension spring in the band spread pulley at position "A" in Figure 2. Turn the pulley counter-clockwise to the stop and string up the

Suitable replacement packs can be found from the list shown below.

REPLACEMENT BATTERY LIST

Manufacturer	Type No.	Manufacturer	Type No.
BRIGHT STAR	.66-50	OLIN	0615 0614
BURGESS	G6M60 F6A60	RAY-O-VAC	AB878 AB994
DELCO	.8760	RCA	VS018 VS019
EVERREADY	.754 753	SEARS ROEBUCK	.67E605
GENERAL	60BF65 60A6F65	USALITE	.680
MONTGOMERY WARD	62A35M 62A33	WESTERN WIZARD	60B6F65 60A6F65
NATIONAL UNION	N808		

NOTE - Only one battery pack of the type listed above is required.

CAUTION - When the receiver is to operate on batteries it is necessary to insert the line cord plug in the chassis receptacle as shown in Fig. 3.

ALIGNMENT PROCEDURE

It will be necessary to remove the receiver chassis from the cabinet to make the I.F. alignment adjustments. To do this, first, remove all the knobs from the control panel; next, unfasten the ANL switch and phone jack from the front panel; then, unsolder the antenna connections, two for the loop antenna and one for the whip antenna; last, remove the two screws fastened to the cabinet through the angle brackets mounted on the chassis and lift out of the case.

The primaries of the I.F. transformers are adjusted from the bottom of the chassis and the secondaries are adjusted from the top of the chassis.

Before starting the alignment procedure, check the position of the general coverage dial pointer at the low frequency end of the range. The pointer should index at the maximum capacity of the tuning capacitor.

Set the following controls before alignment.

- VOLUME Set at maximum
- VOICE/CODE Set at maximum VOICE
- ANL. Set at OFF
- BAND SPREAD Set at 0

ALIGNMENT CHART

Step	Dummy Antenna	Signal Generator Coupling	Signal Generator Frequency	Band Switch Setting	Receiver Dial Setting	Adjust	Remarks
1.	None	Stator plates in center section of tuning gang	455 kc	"1"	1000 kc	A,B,C,D	Maximum audio output at speaker voice coil. Use just enough signal generator output to obtain a 50 mw signal level.
2.	None	See step 1.	455 kc (No mod.)	"1"	1000 kc	E	With the VOICE/CODE switch set at CODE, adjust E for a 1000 cycle note.
3. Just before r-f amplifier alignment, run band spread pointer to zero to check operation of the band spread compression trimmer. If the trimmer is fully tight before the pointer reaches zero, loosen the set screw on the drum dial and turn the drive shaft clockwise until the trimmer is fully compressed. Now back off the trimmer one and one-half turns and turn the pulley counter-clockwise until the pointer indicates 100. Now tighten the set screw on the shaft. This check permits the compression trimmer to work over its operating range without binding. Before proceeding to the next step, set the band spread dial at 0							
4.	10 mmf from ext. antenna lead to chassis.	Couple the generator to the ext. ant. lead thru a 15 mmf capacitor	30 mc	"4"	30 mc	F,G,H	Maximum output as in step 1.
5.	See step 4.	See step 4.	11.5 mc	"3"	11.5 mc	I,J,K	Maximum output as in step 1.
6.	See step 4.	See step 4.	4.4 mc	"2"	4.4 mc	L,M,N	Maximum output as in step 1.
*7.	See step 4.	See step 4.	1500 kc	"1"	1500 kc	O,P,Q	Maximum output as in step 1.

*NOTE - Loop must be reconnected for this step.

MODEL S-72

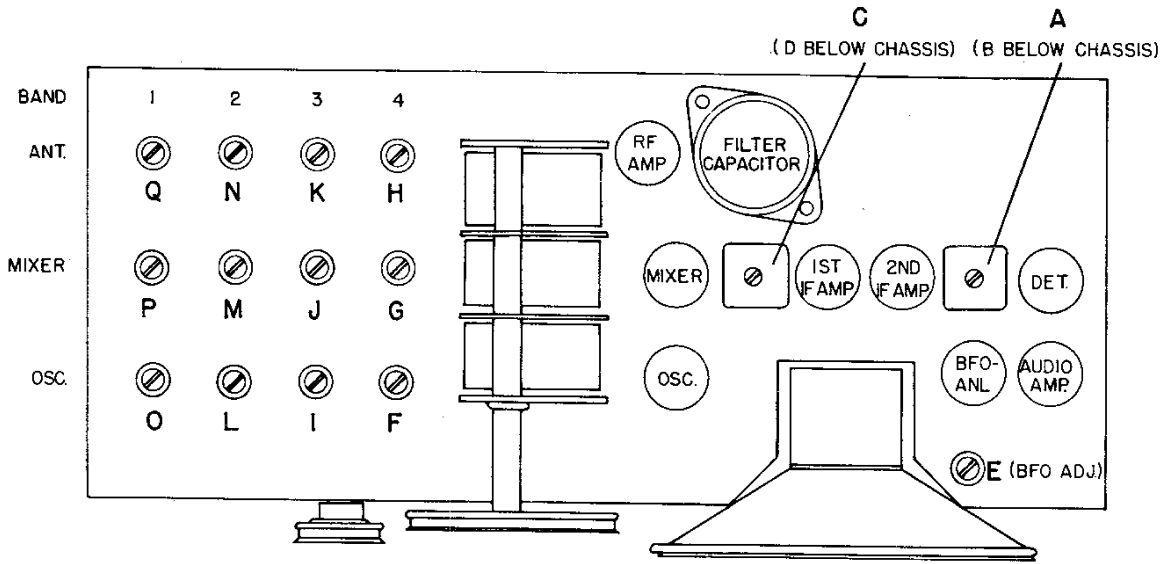

92G782-0

Figure 4. Alignment points

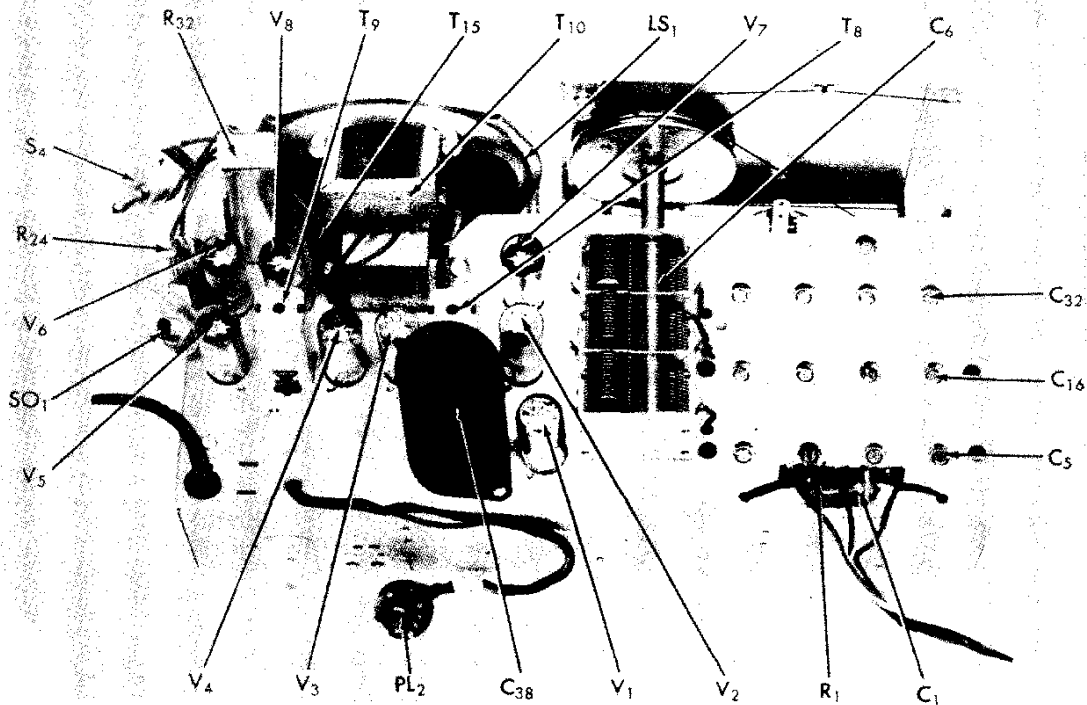

92X781

Figure 5. Top view, component location

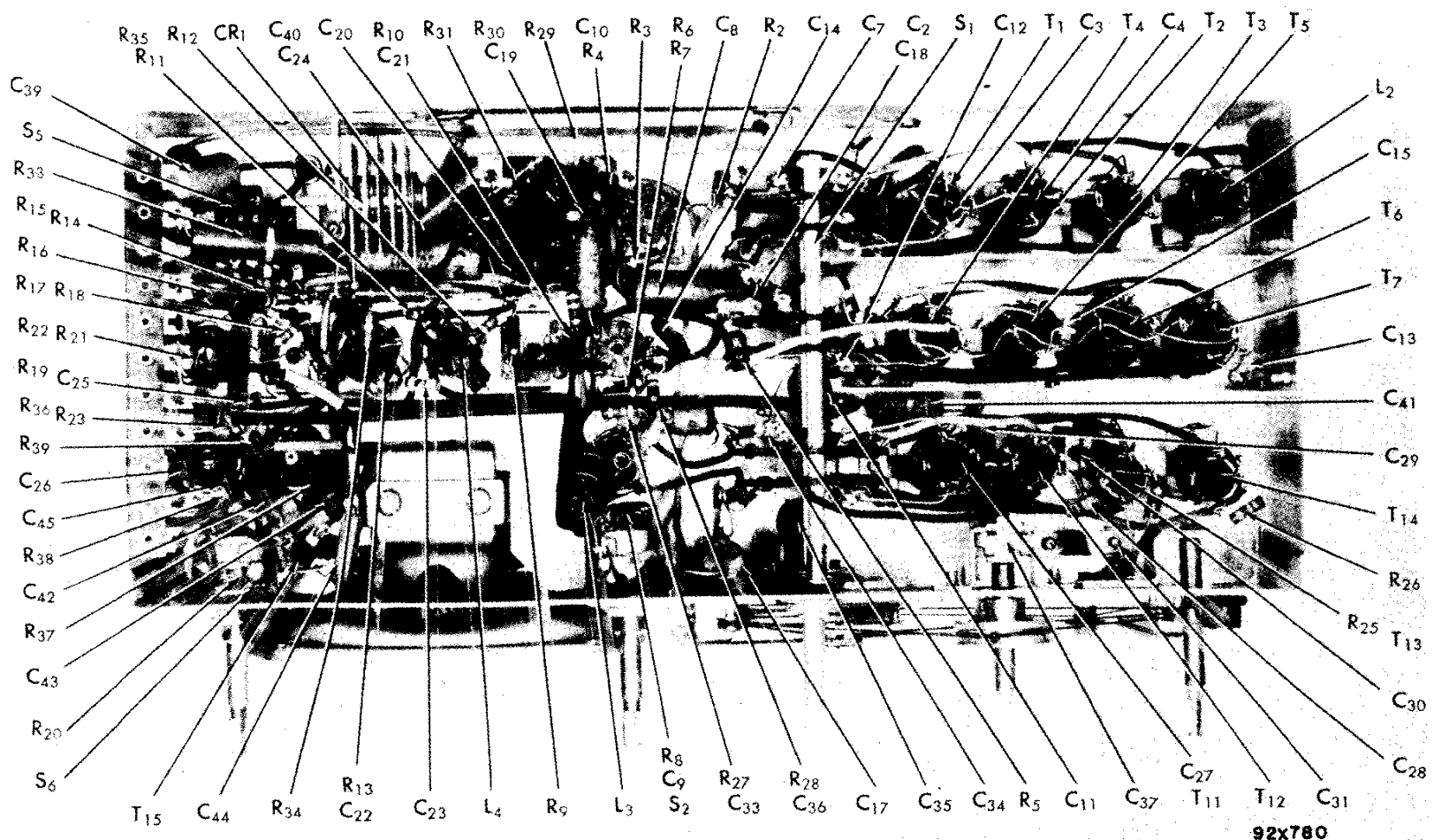

92X780

Figure 6. Bottom view, component location

MODEL S-72

SERVICE PARTS LIST

Ref. No.	Description	Hallcrafters Part Number	Ref. No.	Description	Hallcrafters Part Number
CAPACITORS					
C-1,33,42	.003 mfd., 600 V., tubular	46AZ302J	T-1	Transformer, antenna stage, band 4	51B1139
C-2,13,23,34	100 mmf., 500 V., ceramic	47B20101K5	T-2	Transformer, antenna stage, band 3	51B1138
C-3,4,15	15 mmf., 500 V., ceramic	47B20150K5	T-3	Transformer, antenna stage, band 2	51B1137
C-5	Trimmer, ant. assy., 4 sections (Bands 1,2,3,4)	44B374-1	T-4	Transformer, mixer stage, band 4	51B1143
C-6	Tuning capacitor, 3 section	48C221	T-5	Transformer, mixer stage, band 3	51B1142
C-7,18	68 mmf., 500 V., ceramic	47B20680K5	T-6	Transformer, mixer stage, band 2	51B1141
C-8	.05 mfd., 200 V., tubular	46AU503J	T-7	Transformer, mixer stage, band 1	51B1140
C-9,10,11,14, 20,21,22, 35	5000 mmf., 500 V., ceramic	47A168	T-8	Transformer, 1st I.F.	50C233
C-12	47 mmf., 500 V., ceramic	47B20470K5	T-9	Transformer, 2nd I.F.	50C234
C-16	Trimmer, mixer assy., 4 sec- tions, (Bands 1,2,3,4)	44B374-2	T-10	Transformer, audio output (part of speaker assy. LS-1)	
C-17	Capacitor, resonant (455KC)	46A150	T-11	Transformer, osc. stage, band 4	51B1147
C-19	.01 mfd., 600 V., tubular	46AY103J	T-12	Transformer, osc stage, band 3	51B1146
C-24	.1 mfd., 200 V., tubular	46AU104J	T-13	Transformer, osc. stage, band 2	51B1145
C-25	Capacitor, composite; .002, .005, .0001, .005 mfd, 500 V., ceramic	47A203	T-14	Transformer, osc. stage, band 1	51B1144
C-27	22 mmf., 500 V., ceramic	47B20220K5	T-15	Transformer, B.F.O. (with mtg. clip)	50B402
C-28	50 mmf., 500 V., ceramic	47B20500K5	L-1	Loop antenna	57C125
C-29	3900 mmf., 500 V., mica	47X35A392J	L-2	Coil, antenna loading (band 1)	51B1136
C-30	1400 mmf., 500 V., mica	47X30A142J	L-3	Choke, R.F.	53A008
C-31	Padder, adjustable, (Band 1)	44A376	L-4	Choke, filament	53A121
C-32	Trimmer, osc. assy., 4 sections (Band 1,2,3,4)	44B374	SWITCHES		
C-36	7 mmf., 500 V., ceramic	47X20UK070K	S-1	Switch, band (6 section assy. complete)	60C362
C-37	Capacitor, band spread, (with shaft and bracket)	44B375	S-2	Switch, VOICE/CODE, (Part of r-f gain control, R-8)	
C-38	60-20-20 mfd., 150 V., 1000 mfd., 10 V., electrolytic	45B155	S-3	Switch, TONE	60A361
C-39	.02 mfd., 600 V., moulded paper	46BR203L6	S-4	Switch, ANL. (S.P.S.T.)	60A365
C-40	.02 mfd., 200 V., tubular	46AU203J	S-6	Switch, ON-OFF (D.P.S.T. power switch, part of volume control R-20)	
C-41,44	470 mmf., 500 V., mica	47X20A471K	PLUGS AND SOCKETS		
C-43	100 mmf., 500 V., mica	47X20A101M	PL-1	Line cord	87B1683
C-45,26	1000 mmf., 500 V., ceramic	47B20102K5	PL-2	Battery plug, 6 prong	10A344
C-46	100 mfd., 25 V., electrolytic	45A116	SO-1	Jack, phone	36A036
C-47	5.6 mmf., 500 V., composition	47A160-7	TUBES AND RECTIFIERS		
RESISTORS					
R-1	10,000 ohms, 1/2 watt, carbon	23X20X103K	V-1	Type 1T4, r-f amplifier	90X1T4
R-2,6,10,13, 14,15	4.7 megohms, 1/2 watt, carbon	23X20X475M	V-2,3,4	Type 1U4, mixer, 1st and 2nd i-f amplifier	90X1U4
R-3	150 ohms, 1/2 watt, carbon	23X20X151K	V-5,8	Type 1U5, detector and B.F.O.	90X1U5
R-4,37	22,000 ohms, 1/2 watt, carbon	23X20X223K	V-6	Type 3V4, audio power amplifier	90X3V4
R-5,19	470 ohms, 1/2 watt, carbon	23X20X471K	V-7	Type 1R5, oscillator	90X1R5
R-7,24	100 ohms, 1/2 watt, carbon	23X20X101K	CR-1	Rectifier, selenium	27A151
R-8	Resistor, variable, 500,000 ohms, VOICE/CODE control	25B847	MISCELLANEOUS		
R-9	2200 ohms, 1/2 watt, carbon	23X20X222K		Socket, 7 prong miniature (tube)	6A292
R-11	100,000 ohms, 1/2 watt, carbon	23X20X104K		Lock, line cord	76A397
R-12	6800 ohm, 1/2 watt, carbon	23X20X682K		Escutcheon	7D109
R-16,23,39	2.2 megohms, 1/2 watt, carbon	23X20X225M		Escutcheon, dial	22B250
R-17,27,38	47,000 ohms, 1/2 watt, carbon	23X20X473K		Plate, dial	83C355
R-18,22	470,000 ohms, 1/2 watt, carbon	23X20X474K		Knob	15B172
R-20	Resistor, variable, 2 megohm, VOLUME control	25B839		Knob (with dot)	15B177
R-21	3.3 megohms, 1/2 watt, carbon	23X20X335M		Pointer, main tuning	82A161
R-25	1000 ohms, 1/2 watt, carbon	23X20X102K		Pointer, band spread	82A161-1
R-26	680 ohms, 1/2 watt, carbon	23X20X681K		Dial cord	38A001
R-28	47 ohms, 1/2 watt, carbon	23X20X470K		Spring, general coverage dial	75A012
R-29	270 ohms, 2.3 watts; 350 ohms, 5.5 watts; W.W.	24A912		Spring, band spread dial	75A070
R-30,34	560 ohms, 1 watt, carbon	23X30X561K		Assembly, pulley, bushing and cam	41X13804
R-31	680 ohms, 1 watt, carbon	23X30X681K		Pulley, idler	28A052-7
R-32	600 ohms, 9.3 watts, W.W.	24A913		Shaft, main tuning	74A274
R-33	22 ohms, 2 watts, W.W.	24BV 220E	LS-1	Antenna, whip	72A035
R-35	1200 ohms, 1/2 watt, carbon	23X20X122K		Antenna, insulator	65A533
R-36	33 ohms, 1/2 watt, carbon	23X20X330K		Speaker	85C093
				Strap, battery	76B467
				Cabinet	78F423

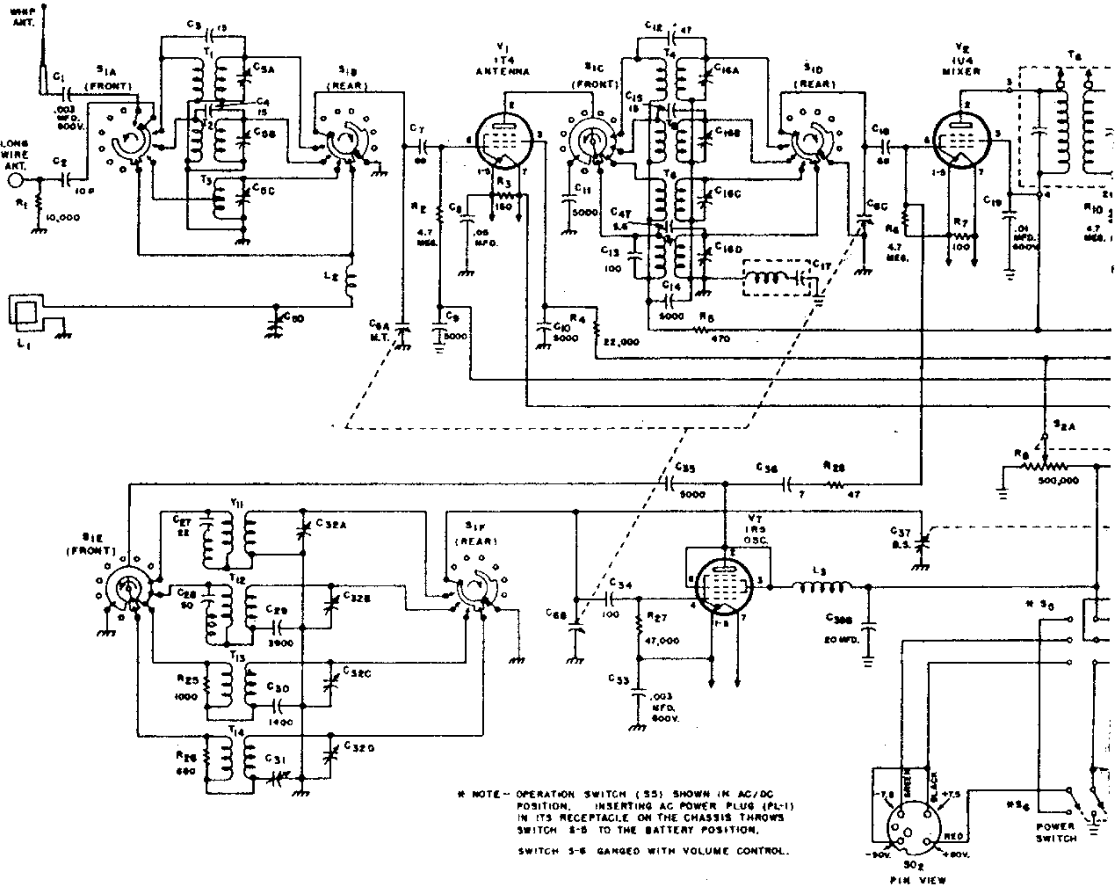

- NOTES -
1. SOCKET VIEWS ARE BOTTOM VIEWS.
 2. ALL VOLTAGES ARE MEASURED BETWEEN TUBE SOCKET TERMINALS & THE ELECTRICAL GROUND BUSS (NOT CHASSIS) WITH ZERO SIGNAL INPUT.
 3. LINE VOLTAGE - 117V AC. BATTERY VOLTAGES TAKEN WITH FRESH BATTERY PACK.
 4. ALL VOLTAGES SHOWN ARE DC UNLESS OTHERWISE SPECIFIED.
 5. DC VOLTAGES SHOWN WERE MEASURED WITH AN ELECTRONIC VOLTMETER.
 6. "NC" - NO CONNECTION.
 7. "NR" - NOT READABLE (READING GENERALLY MEANINGLESS).
 8. SPACE PROVIDED FOR SERVICE METER READINGS.
 9. UPPER VOLTAGE READINGS IN INDICATOR SPACE SHOW BATTERY OPERATION.
 10. VOLTAGES FOR TUBE V-8, ARE SHOWN WITH VOICE-CODE SWITCH IN CODE POSITION.
 11. ALL READINGS TAKEN WITH LINE PLUG POLARIZED SO THAT GROUND BUSS & CHASSIS ARE AT SAME POTENTIAL AS THE CHASSIS GROUND.

92D777

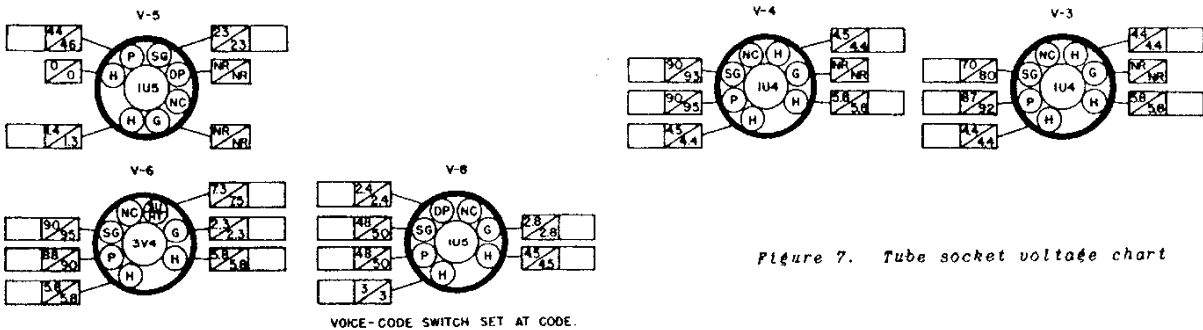
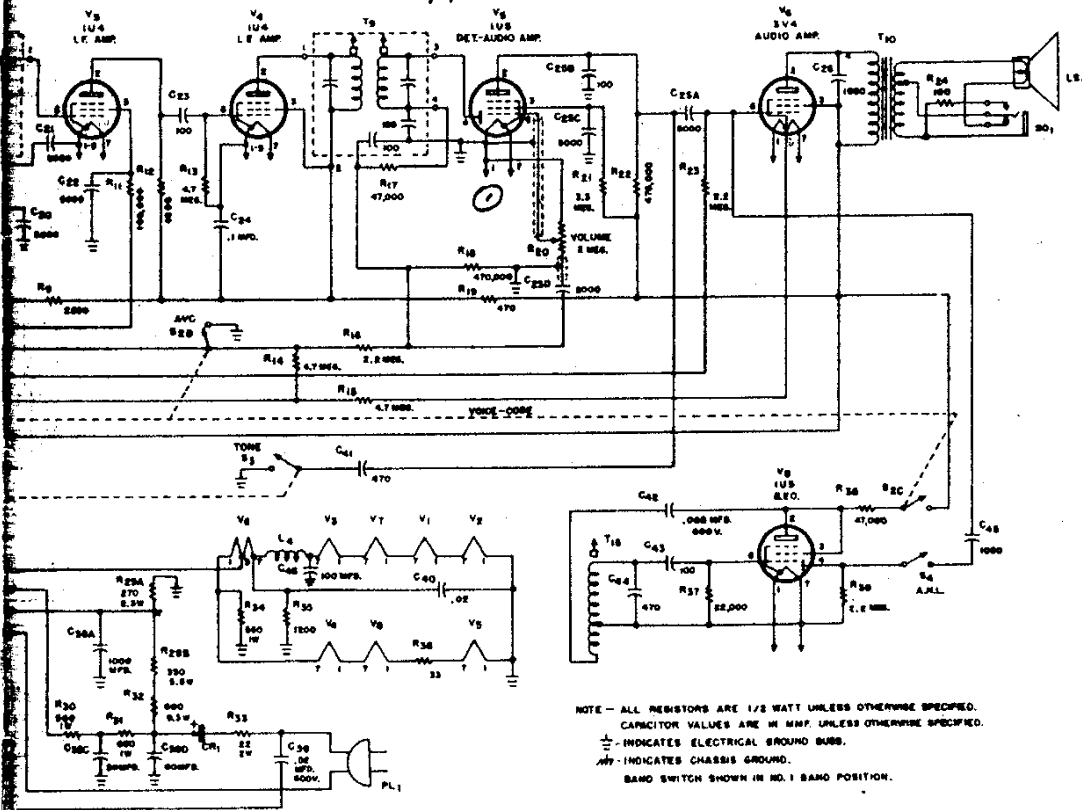

Figure 7. Tube socket voltage chart

FRONT APRON
BOTTOM VIEW OF CHASSIS

*0 - reverse leads to filament
ground # 7.
Suppressor is returned to pin 1 internally*



NOTE - ALL RESISTORS ARE 1/2 WATT UNLESS OTHERWISE SPECIFIED.
CAPACITOR VALUES ARE IN MMF. UNLESS OTHERWISE SPECIFIED.
⊥ INDICATES ELECTRICAL GROUND BUSS.
⏏ INDICATES CHASSIS GROUND.
BAND SWITCH SHOWN IN NO. 1 BAND POSITION.

Fig. 8. Schematic diagram

LAST RESISTOR SYMBOL - R39
LAST CAPACITOR SYMBOL - C47

802510-0

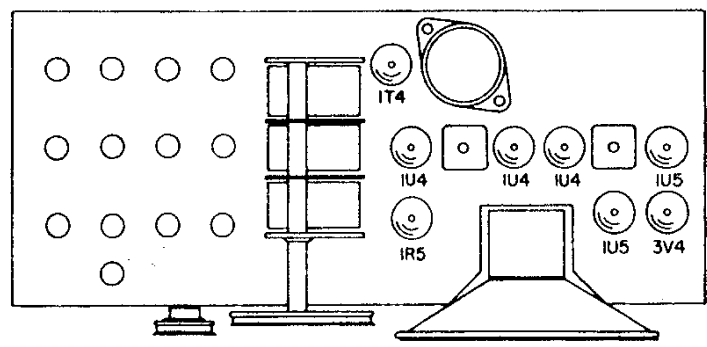
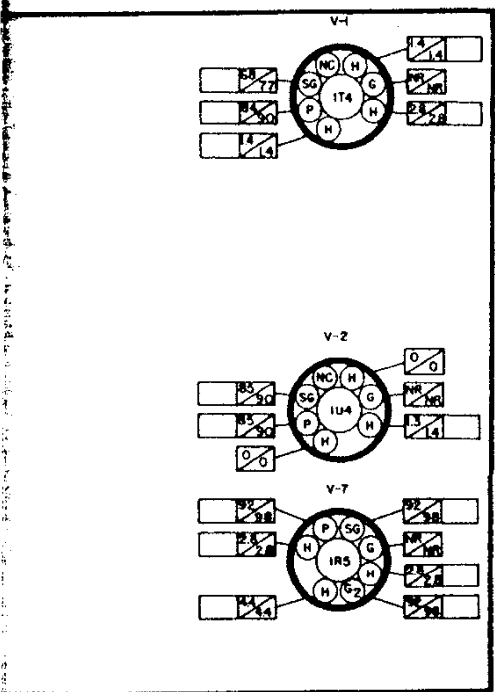

92C773-0

Fig. 9. Top view, location of tubes and dial lamp