

communications

**OPERATING and SERVICE
INSTRUCTIONS**

**SX-71
&
SX-71U
RUN 4**

the hallicrafters co.

MANUFACTURERS OF RADIO AND ELECTRONIC EQUIPMENT, CHICAGO 24, U. S. A.

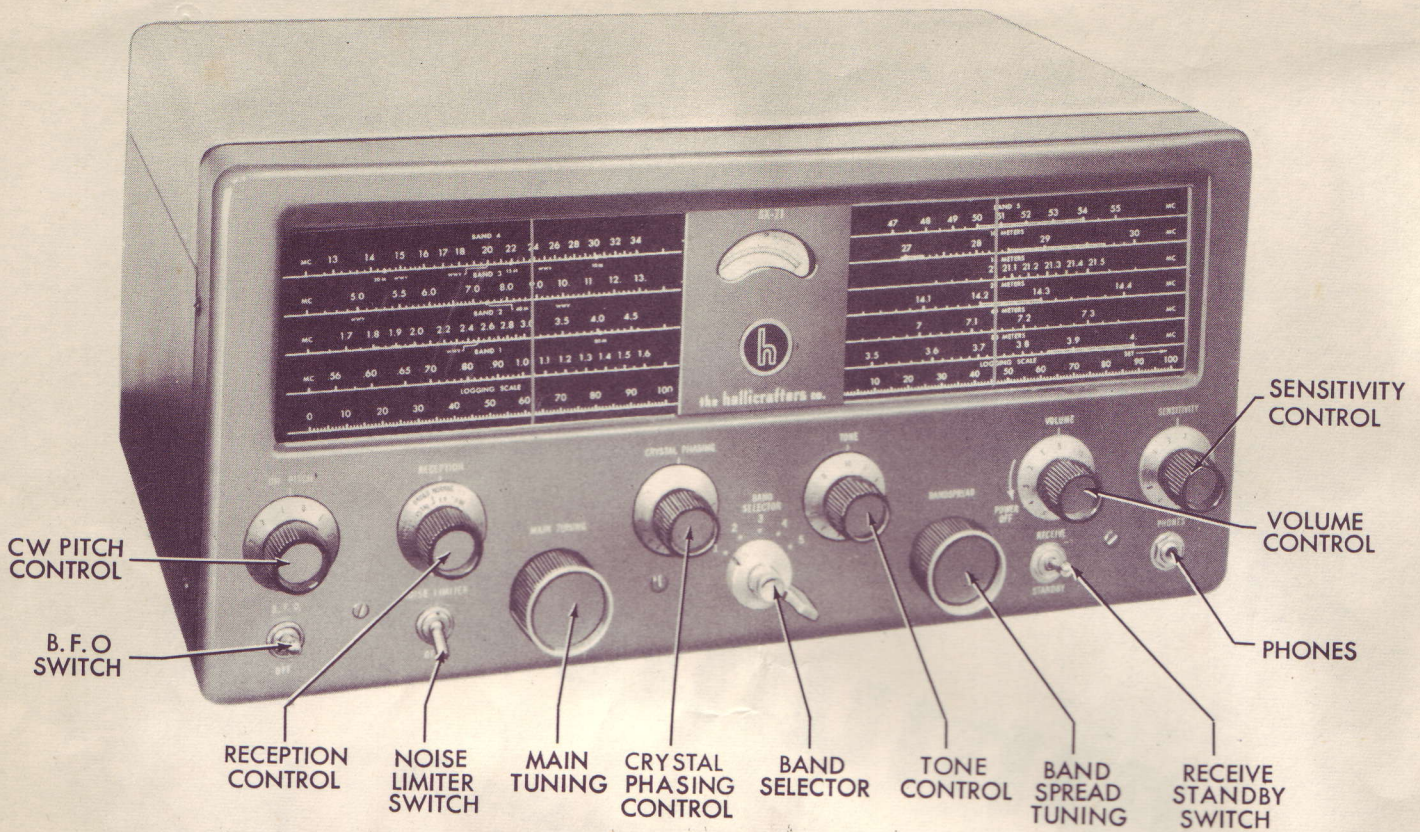

FIG. 1. COMMUNICATIONS RECEIVER MODEL SX-71

92X1841

DESCRIPTION

The Model SX-71 is a precision built, highly sensitive, double conversion superheterodyne communications receiver which employs 11 tubes plus voltage regulator and rectifier and covers the frequency range of 560 kilocycles (KC) to 56 megacycles (MC). The receiver is designed for reception of code (CW), amplitude modulated (AM) and narrow band frequency modulated (NBFM) signals over its entire frequency range as shown below. The use of double conversion makes possible greater image rejection than is practical in a single conversion superheterodyne receiver.

For ease and flexibility of operation, two extra-wide slide rule dials are provided. One provides for general coverage over the frequency range of 560 KC to 34 MC and the other is a bandspread dial calibrated specifically for the 80, 40, 20, 15, 10 and 6 meter amateur bands. The electrical BANDSPREAD control provides a vernier or fine tuning adjustment throughout the entire tuning range of the receiver.

For the ultimate in selectivity, a variable crystal filter and a crystal phasing control are used so that the receiver can be peak adjusted for that hard-to-read signal.

A carrier level meter has been provided to aid in tuning the receiver and to give a relative indication of received signal strength.

The audio system provides sufficient audio power to operate either a speaker or headphones. For speaker operation, a separate external loud speaker of either 3.2 or 500 ohms is required. A phono jack permits attachment of a record player.

An automatic series noise limiter, operated by a toggle switch, permits the operator to reduce the background noise caused by severe electrical disturbances.

The RECEIVE-STANDBY switch permits disabling of the receiver for standby periods without having to wait for the tube heaters to reach operating temperature when reception is again required.

The SX-71 normally operates from a 105-125 volt 50/60 cycle alternating current (AC) power source. The SX-71U, a universal model of the SX-71, permits operation from 25/60 cycle AC sources at voltages ranging from 105 to 250 volts. Both models have provision for operation from an external DC power source. The power consumption of each model is 90 watts.

FREQUENCY COVERAGE

BAND	FREQUENCY RANGE	RECEPTION
1	560 KC - 1600 KC	AM/NBFM/CW
2	1650 KC - 4700 KC	AM/NBFM/CW
3	4.7 MC - 13.4 MC	AM/NBFM/CW
4	12.8 MC - 34 MC	AM/NBFM/CW
5	46 MC - 56 MC	AM/NBFM/CW

Your careful attention is especially invited to the installation and operating instructions. They have been provided to insure the satisfaction you have a right to expect from a Hallicrafters "Precision Built" product. Your receiver has an unusually high degree of sensitivity necessary to receive weak and distant stations. Careless operation of a high sensitivity receiver may result in excess noise or background hiss. These undesirable effects can be held to a minimum by careful adjustment of the sensitivity, tuning and tone controls as well as proper selection and arrangement of the antenna.

INSTALLATION

UNPACKING - Check all shipping tags and labels for instructions before removing or destroying them.

LOCATION - The receiver is equipped with rubber mounting feet for table top or shelf mounting. When locating the receiver, avoid excessively warm locations and recessed installations which prevent proper air circulation. The separate loud speaker should not be placed on the top of the cabinet but should be located as far from the receiver as is practical.

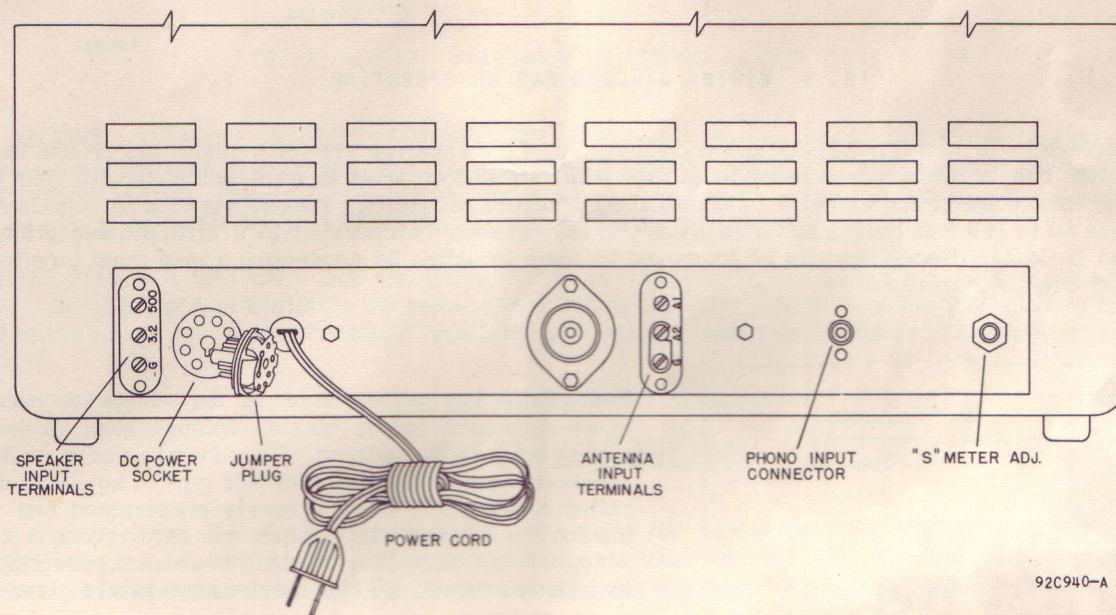

FIG. 2. REAR VIEW

POWER SOURCE - This receiver may be operated directly from an AC source or indirectly from a DC or battery source.

AC OPERATION - The SX-71 can be operated directly from a 105-125 volt, 50/60 cycle AC power outlet. The universal model, the SX-71U, is designed for operation from 115, 130, 150, 220 and 250 volt, 25/60 cycle AC sources. A selector switch, located on the power transformer, permits operation of the SX-71U on any of the line voltages shown. The normal power consumption of each model is 90 watts. If in doubt as to the frequency and voltage rating of your power source, contact the local power company representative. Attempting to operate the receiver from sources of power not specified may result in costly repairs.

CAUTION - When operating the universal model, it is essential that the selector switch setting correspond to the operating line voltage before connecting the receiver to the AC power source.

NOTE: The receiver will not operate from an AC source unless the JUMPER PLUG is inserted in the DC POWER SOCKET. See Fig. 2.

DC OPERATION - The receiver may be operated from a 6 volt DC source (storage battery or equivalent) and a 270 volt DC supply in the form of "B" batteries, vibrator power supply or motor generator set. The voltage and current requirements for the DC operation are listed below.

DC power is connected to the receiver through the DC POWER SOCKET located on the rear apron of the chassis. The JUMPER PLUG, normally located in this socket for AC operation, is replaced with a standard octal plug for DC operation. Wire the octal plug for DC operation as shown in Fig. 3.

VOLTAGE AND CURRENT REQUIREMENTS FOR DC OPERATION

"B" Voltage	270 volts
"B" Current	110 ma
Heater Voltage	6.3 volts
Heater Current	4.4 amps.

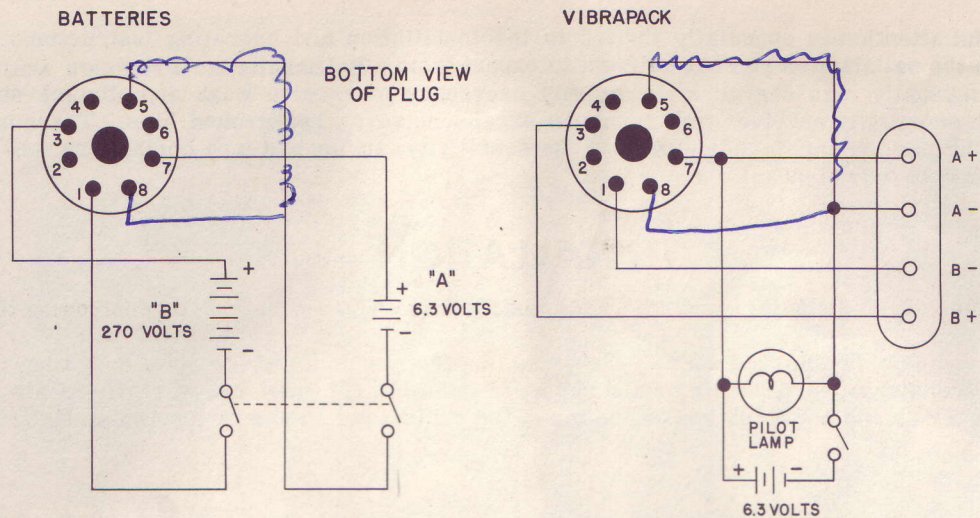

92B1453

FIG. 3. WIRING DIAGRAM FOR DC OPERATION

ANTENNA - The terminals marked A1, A2 and G on the back of the receiver are for antenna and ground connection. Satisfactory results can be obtained in most localities with the 15 foot antenna wire included with your receiver. Simply uncoil the wire, connect one end of it to terminal A1 and then connect the jumper between terminals A2 and G. An outside antenna 50 to 100 feet long may be necessary if the receiver is operated in a difficult reception area or steel constructed building. Reception may be improved in some locations by connecting a lead from terminal G to a cold water pipe or outside ground rod.

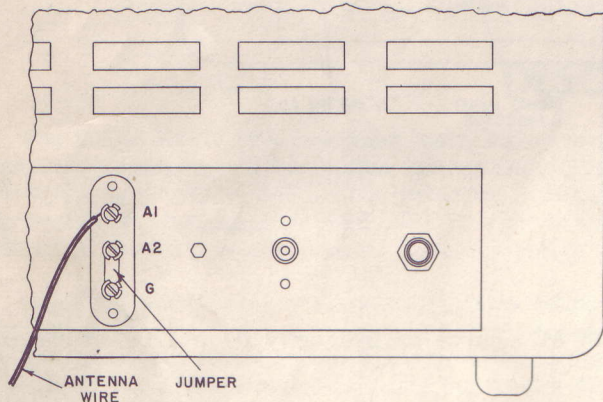

92B1451-A

FIG. 4. SINGLE WIRE ANTENNA INSTALLATION

For really top performance on the shortwave bands, there is no substitute for an outside antenna such as used by the commercial radio stations. Provision has been made on your receiver for the connection of this type of antenna, commonly called a doublet. When properly constructed and installed, the doublet antenna will provide not only optimum shortwave reception but excellent standard broadcast reception as well. Installation details for the doublet antenna are given below.

DOUBLET ANTENNA - The overall length (in feet) of the doublet antenna is determined by dividing 468 by the frequency (in megacycles) at the high end of the range to which you wish to listen. A doublet antenna is directional broadside to its length and should be so oriented with respect to a desired station for maximum signal pickup.

By feeding the doublet antenna with a 300-ohm transmission line, a broader frequency response is obtained than that possible with 50-75 ohm line.

When feeding the antenna with a ribbon type transmission line, connect the line to terminals A1 and A2 and disconnect the jumper between A2 and G.

When using a coaxial transmission line, connect the inner conductor to A1, the outer conductor to A2 and place the jumper between A2 and G.

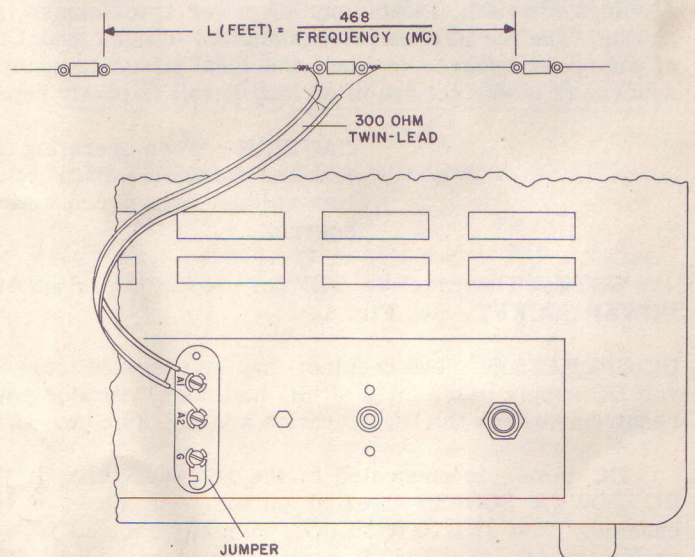

92B1452-A

FIG. 5. DOUBLET ANTENNA INSTALLATION

SPEAKER CONNECTION- Three screw type terminals, marked 3.2, 500 and G, are provided on the rear apron of the chassis for connection to an external 3.2 or 500 ohm speaker. It is recommended that the Hallicrafters speaker R-46 be employed.

RECORD PLAYER CONNECTION- - A shielded type phono jack is provided on the rear of the chassis to accommodate any record player employing a crystal pickup. Refer to Fig. 6 for wiring details.

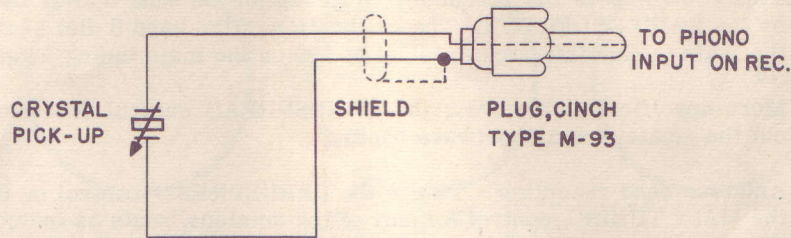

92B1395-A

FIG. 6. WIRING DIAGRAM FOR RECORD PLAYER CONNECTION

REMOTE RECEIVE / STANDBY SWITCH CONNECTION - The receiver may be disabled remotely by connecting a remote spst switch between pins 1 and 4 of the JUMPER PLUG (see Fig. 2). To operate the receiver remotely, set the RECEIVE/STANDBY switch, located on the front panel of the receiver, to the STANDBY position. The receiver can then be placed in RECEIVE or STANDBY operation with the remote switch.

TRANSMITTER CONTROL SWITCH - One terminal of the spdt RECEIVE/STANDBY switch is connected to pin 2 of the DC POWER SOCKET and is available for transmitter relay control. The arm of the RECEIVE/STANDBY switch is grounded to the chassis. In the STANDBY position, pin 2 is grounded; in the RECEIVE position, pin 2 is insulated from ground.

OPERATION

Each control of the Model SX-71 communications receiver performs a definite function that contributes to the outstanding reception capabilities. Full appreciation of the receiver is to be expected only after you have become familiar with each of the controls and the effect their operation has on the receiver's performance.

RADIO TELEPHONE RECEPTION- To receive amplitude modulated (AM) and narrow band frequency modulated (NBFM) radio telephone signals, the following use of the controls is recommended to obtain optimum performance from the Model SX-71 communications receiver.

- | | |
|-------------------------------|--|
| VOLUME control | This control turns the receiver on and off in addition to controlling the volume. Turn the control clockwise to turn the receiver on or increase volume and counterclockwise to reduce volume. To turn the receiver off, turn the VOLUME control counterclockwise beyond the point of switch action. |
| RECEIVE/STANDBY switch | This switch, normally set at RECEIVE, is particularly useful to the "ham" as it permits disabling of the receiver for standby periods, at the same time maintaining the tube heaters at operating temperature for instant use. The receiver is disabled by setting this switch to the STANDBY position. |
| B.F.O. switch | This switch is set at OFF for RADIO TELEPHONE RECEPTION. |
| RECEPTION control | This control should be set at N.B.F.M. for the reception of narrow band frequency modulated radio telephone stations located in any of the shortwave bands. To receive amplitude modulated radio telephone signals over any portion of the frequency range, three positions of the RECEPTION control may be used: NORMAL I.F., BROAD CRYSTAL and SHARP CRYSTAL. The broadest bandwidth is obtained in the NORMAL I.F. position and the narrowest in the SHARP CRYSTAL position. Note that as the receiver is made more selective, the background noise and interference from adjacent channels is reduced. The use of the crystal filter will require an adjustment of the CRYSTAL PHASING control. Refer to "USE OF CRYSTAL PHASING CONTROL" for details. |
| BAND SELECTOR control | Set the BAND SELECTOR for the desired position as indicated by the band number on the dial scale. Bands 1 through 4 are found on the left hand or main tuning dial and band 5 is on the right hand or bandspread dial. |

- MAIN TUNING control This control sets the frequency of reception on bands 1 through 4 after the individual band has been selected by the BAND SELECTOR. Frequencies of all bands are shown in megacycles (MC). For reception on band 5, this control must be set for 100 on the logging scale.
- IMPORTANT - The calibrations on the main tuning dial scales will be true only when the bandspread dial pointer is set at 100 on the bandspread logging scale.
- BANDSPREAD control This control sets the frequency of reception on band 5 after the band has been selected by the BAND SELECTOR. The calibration of the band 5 dial scale will be true only when the main tuning dial pointer is set at 100 on the main tuning logging scale.
- More specifically, however, the BANDSPREAD control functions to electrically spread out the amateur and shortwave bands.
- Amateur band reception - To use the BANDSPREAD control on the amateur bands, index the MAIN TUNING control for any of the amateur bands as indicated by the white dots on the main tuning dial. Then tune through the band with the BANDSPREAD control. The frequency of reception can be read directly from the bandspread dial scale.
- Short Wave reception - To tune shortwave broadcast stations with the BANDSPREAD control; set the bandspread dial pointer at 100; set the main tuning dial pointer slightly higher in frequency than the desired group of short wave stations and then tune in the stations with the BANDSPREAD control. Note that the frequency of reception cannot be read directly from either set of dial scales when tuning in this manner. However, short wave stations may be logged by recording the dial pointer settings indicated on the bandspread and main tuning logging scales.
- SENSITIVITY control This control is normally set fully clockwise for maximum sensitivity. For a correct "S" meter indication, the SENSITIVITY control must be set fully clockwise.
- TONE control This control attenuates the high audio frequencies to the extent required by various receiving conditions and should be set at 10 for normal response. Turn the TONE control counterclockwise to attenuate the high frequency audio response.
- NOISE LIMITER switch This switch is normally set to the OFF position. When natural or "man made" static interferes with reception, this switch should be set at NOISE LIMITER to reduce the interference.
- C.W. PITCH control This control is not used for RADIO TELEPHONE RECEPTION.
- CW RECEPTION** - The following use of the controls is recommended for CW (code) reception to obtain optimum performance from the receiver.
- B.F.O. switch This switch should be set at B.F.O. for CW RECEPTION.
- C.W. PITCH control This control varies the frequency of the beat frequency oscillator thus varying the pitch of the CW code signal. After tuning in a code signal, this control should be adjusted for the tone most pleasing to the operator.
- VOLUME control Same as for RADIO TELEPHONE RECEPTION.
- RECEIVE/STANDBY switch Same as for Radio TELEPHONE RECEPTION.
- BAND SELECTOR control Same as for RADIO TELEPHONE RECEPTION.
- MAIN TUNING control Same as for RADIO TELEPHONE RECEPTION.
- BANDSPREAD control Same as for RADIO TELEPHONE RECEPTION.
- RECEPTION control Set this control at NORMAL I.F. If a greater selectivity is desired, this control should be set at BROAD CRYSTAL or SHARP CRYSTAL. The use of the crystal filter will require an adjustment of the CRYSTAL PHASING control. Refer to "USE OF CRYSTAL PHASING CONTROL" for details.
- TONE control This control should be set at 0 for CW RECEPTION.

SENSITIVITY control Increase receiver sensitivity by turning the **SENSITIVITY control** clockwise. If strong code signals block the receiver, reduce the sensitivity slightly.

NOISE LIMITER switch The noise limiter circuit is particularly useful for code reception because it "clips" the intermittent noise peaks down to the level of the desired signal where they tend to become unnoticeable. See Fig. 7 for an illustration of limiter action.

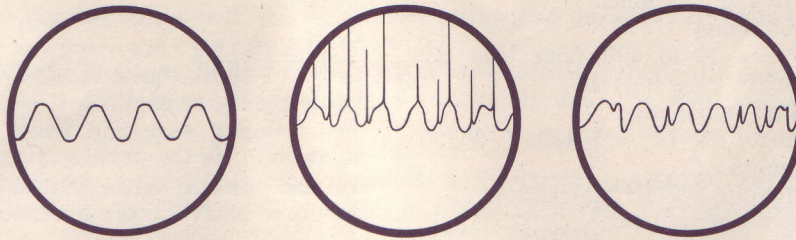

FIG. 7. NOISE LIMITER ACTION

92X972

USE OF CRYSTAL PHASING CONTROL - This control permits the discrimination of interfering signals whose frequencies are very near the desired signal. To attain single signal reception with the SX-71, first set the **RECEPTION** switch to either **BROAD CRYSTAL** or **SHARP CRYSTAL**. Choose a strong signal, preferably a commercial station because a commercial station is likely to remain on long enough for you to complete the phasing adjustment for single signal reception.

You will find on tuning across this signal that it has two amplitudes. Turn the **CRYSTAL PHASING** control until the weaker of the two amplitudes is reduced to a minimum. Then, tune to the stronger of the two amplitudes and adjust the **C.W. PITCH** control (for c-w reception) to a tone most pleasing to you. This adjustment for single signal selectivity will require no further adjustment unless you change the **CRYSTAL PHASING** control. See Fig. 8 for an illustration of single signal operation.

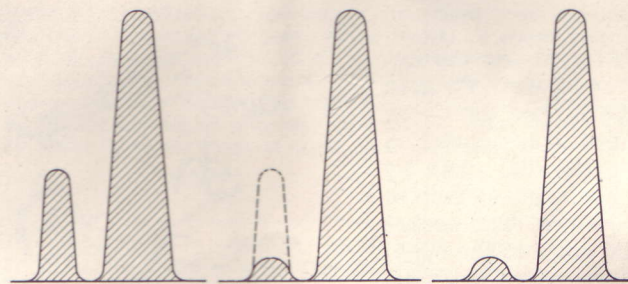

FIG. 8. SINGLE SIGNAL OPERATION

92X974

NOTES ON NBFM RECEPTION - When tuning in amateur radiophone stations using narrow band frequency modulation, tune for minimum distortion. Note that in general, the headset or speaker volume is slightly less than for AM phone reception. This is normal. However, when the volume level is very low, it indicates that the deviation of the FM signal is considerably below ± 2.5 KC. When the received signal is loud and very distorted, the transmitted signal has a deviation in excess of ± 2.5 KC. In extreme cases of distortion, reception may be improved by switching to normal AM reception and tuning off to one side of the transmitted carrier as is customary with receivers not equipped with FM detectors, however, in this case the quieting effects of FM are not available. The SX-71 receiver has been designed to provide optimum results when receiving FM signals having a maximum of ± 2.5 KC deviation. Note that when the receiver is switched to NBFM, the "S" meter is rendered inoperative.

USE OF THE "S" METER - The "S" meter or carrier level meter has been provided to aid in tuning the receiver for amplitude modulated radio telephone reception and to give an indication of relative carrier strength of each incoming AM signal. For a correct "S" meter indication, the **SENSITIVITY control** must be fully clockwise and the receiver must be tuned for a maximum reading on the "S" meter. The "S" meter circuit is disabled for CW and narrow band FM reception.

RECORD PLAYER OPERATION - Connect the record player to the receiver; set the **RECEPTION control** to **PHONO** and then place the receiver in operation by turning the **VOLUME control** clockwise beyond the point of switch action. Operate the **VOLUME** and **TONE** controls as for **RADIO TELEPHONE RECEPTION**. The setting of the remaining controls is immaterial as they are not in use for record player operation.

HEADPHONE OPERATION - The **PHONES** jack, located on the front panel, permits the use of headphones with this receiver. Insertion of the headphones disables the speaker. Use any standard headset of low or medium impedance.

SERVICE

GENERAL SPECIFICATIONS

Tubes	11 plus voltage regulator and rectifier
Speaker Output	3.2 and 500 ohms
Headset Output	500 ohms
Antenna Input	For a 50 to 600 ohm line or single wire lead-in
Phono Input	High Impedance
Power Supply	Model SX-71: 105-125 V. 50/60 cycles AC Model SX-71U: 105-250 V. 25/60 cycles AC
Power Consumption	90 Watts
Reception	AM/NBFM/CW

FREQUENCY COVERAGE

Band	Frequency Range	Intermediate Frequency
1	560 KC - 1600 KC	455 KC
2	1650 KC - 4700 KC	455 KC
3	4.7 MC - 13.4 MC	2.075 MC & 455 KC
4	12.8 MC - 34 MC	2.075 MC & 455 KC
5	46 MC - 56 MC	2.075 MC & 455 KC

DIAL LAMP REPLACEMENT- Refer to Fig. 11 for the location of the dial lamps used in the receiver. To gain access to defective lamps, raise the hinged top cover of the cabinet. The dial lamp sockets are mounted on metal brackets which are fastened to the dial plate by self-tapping hex head screws. To replace a defective lamp, remove the bracket mounting screws. The socket and defective lamp can then be brought out into the open. The two end lamps should be replaced with a 6-8 volt, 150 ma (brown bead) Mazda #47 pilot lamp or equivalent. When replacing the center lamps, use a 6-8 volt, 250 ma (blue bead) Mazda #44 pilot lamp or equivalent.

TUBE REPLACEMENT

- The tube types and their relative location in the receiver are shown in Fig. 11. Raise the hinged top cover of the cabinet to gain access to all tubes. When installing a replacement octal tube, insert the center guide pin into the center hole of the tube socket, rotate the tube until the key on the guide pin drops into the notch in the socket hole and push down until the base of the tube rests firmly on the socket. A slightly different technique must be used on the miniature tubes. They have seven small pins which must be lined up with the socket holes before pushing the tube into place. Handle all tubes with care as they are considered fragile and will not withstand mechanical abuse.

"S" METER ADJUSTMENTS

MECHANICAL ADJUSTMENT

- Turn the receiver off. Directly below the "S" meter on the front panel is a round metal medallion which is pivoted at the bottom so that it may be rotated to one side to provide access to the "S" meter adjustment screw. Carefully rotate this adjustment screw until the pointer is in line with the right hand index mark on the "S" meter.

ELECTRICAL ADJUSTMENT

1. Short the antenna terminals to the chassis.
2. Set the RECEIVE/STANDBY switch at RECEIVE, B.F.O. switch at OFF, SENSITIVITY control fully clockwise and the NOISE LIMITER switch at OFF.
3. Turn the receiver on.
4. The electrical adjustment control for the "S" meter is located on the rear apron of the chassis (see Fig. 2). Slowly rotate this control until the "S" meter pointer indicates zero.

RESTRINGING DIAL CORD - The dial drive system of the SX-71 consists of four separate string drives. The two drive shaft string systems are identical; the two pointer drive systems are similar but right and left handed.

DRIVE SHAFT - To restring either one, use a 26 inch length of 30 lb. test dial cord. Tie one end of the cord to the spring at position 1, stretch the spring and follow the stringing sequence 1 to 9 as shown in Fig. 9. At position 9, tie the cord securely to the spring. Note that two and one half turns of dial cord are wrapped around the drive shaft for proper traction.

POINTER DRIVE - To restring either one, use a 66 inch length of 30 lb. test dial cord. Tie one end of the dial cord to the spring at position A, stretch the spring and follow the stringing procedure A through U as shown in Fig. 9. At position U, tie the cord securely to the spring.

With the pointer drive pulleys positioned as shown in Fig. 9, the tuning capacitor plates should be fully meshed. The main tuning and bandspread dial pointers should be fastened to the dial cord and aligned with the 0 positions on the logging scales. The ends of the pointers should be carefully crimped around the dial cord and cemented in place.

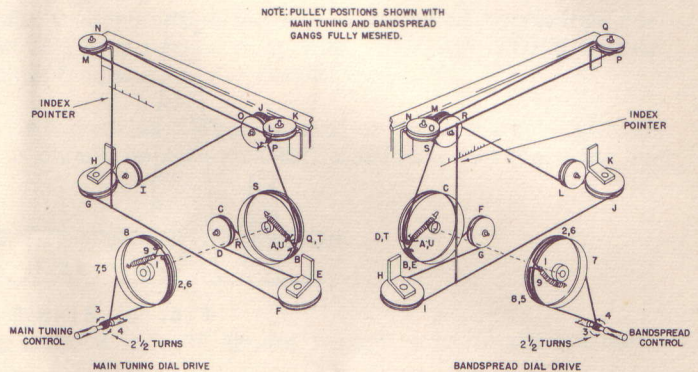

FIG. 9. DIAL CORD STRINGING PROCEDURE 92C962-A

I-F ALIGNMENT PROCEDURE

- EQUIPMENT REQUIRED:**
1. Vacuum tube voltmeter (VTVM)
 2. Signal Generator covering 455 KC and 2.075 MC
 3. Output meter. (Use AC scale of VTVM)

It is necessary to remove the receiver chassis from the cabinet to make the I-F alignment. The chassis is held in the cabinet by two screws on the bottom rear and by screws on the side and bottom of the panel flanges.

The output meter should be connected between the 500 ohm speaker terminal and ground. The output of the receiver should be properly loaded by means of a speaker or dummy load. Speaker loading will enable the operator to monitor the signal.

The following adjustments were made with the VOLUME, TONE and SENSITIVITY controls fully clockwise, NOISE LIMITER switch at OFF, RECEIVE/STANDBY switch at RECEIVE, CRYSTAL PHASING control at zero and both dials set at 50 on the logging scale. With the CRYSTAL PHASING control set at zero, the capacitor plates should be half meshed. Refer to Figs. 11 & 12 for location of all adjustments.

Step	Signal Gen. Coupling	Signal Gen. Frequency	Receiver Control Settings	Receiver Dial Settings	Adjust	Remarks
*1	Connect gen. to stator of gang. (center section) through a .00025 mfd. capacitor.	455 KC No Modulation	BAND SELECTOR at 2. RECEPTION SWITCH at BROAD CRYSTAL. BFO switch at BFO.	Both dials set at 50 on the logging scale.	BFO Slug	Remove CW PITCH control knob and set shaft for a zero beat. Do not replace knob.
*2	Connect gen. to pin 4 of V-5 through a .00025 mfd mica capacitor.	455 KC (approx.) No Modulation	Adjust CW-PITCH for a 400-1000 cycle note. Other controls same as Step 1.	Same as Step 1	U	While turning the slug very slowly in one direction, slowly "rock" the signal generator. As the adjustment passes through the response of the crystal filter, the output goes through a maximum, dips down, and starts going up again. The correct setting of this slug is in the center of the observed dip. A swishing note, in contrast to the sharp crystal tone will be apparent when the correct adjustment has been reached.
<p>*NOTE: The crystal filter I-F transformer secondary winding (adjustment U) is carefully adjusted at the factory to the frequency of the crystal. A signal generator which may be accurately set to within .25 KC of any frequency between 450 to 460 KC is required to make this adjustment. Since the average service signal generator will not meet this requirement, DO NOT attempt to make this adjustment unless a suitable signal generator is available. Start the I-F alignment with Step 3 when a standard type of signal generator is used.</p>						
3	Same as Step 1	Crystal Frequency	RECEPTION SWITCH at SHARP CRYSTAL. Other controls same as Step 1.	Same as Step 1	Sig. Gen.	Adjust the generator frequency for maximum output. This will be the exact frequency of the crystal. A slight reduction in output will be noted when switching from BROAD to SHARP CRYSTAL.
4	Same as Step 1	Same as Step 3	Same as Step 1	Same as Step 1	BFO slug	Rotate shaft of C. W. PITCH control until a zero beat is obtained. Replace knob with zero in line with the panel index mark.
5	Same as Step 1	Same as Step 3 (Modulated)	RECEPTION SWITCH at NORMAL I.F. BFO switch at OFF. Other controls same as Step 1.	Same as Step 1	V W X Y Z 1 2	Maximum output Maximum output Maximum output Maximum output Maximum output Maximum output Repeat above steps for maximum gain.
6	Same as Step 1	Same as Step 3. Increase output to approx. 1000 microvolts.	RECEPTION SWITCH at NBFM. Other controls same as Step 1.	Same as Step 1	3	Connect the test circuit shown in Fig. 10 to test points (A) and (B). Adjust core (3) for a zero reading between a positive and negative peak.
7	Same as Step 1. To prevent a spurious indication, keep the generator output as low as possible.	2.075 MC Modulated	RECEPTION SWITCH at NORMAL I.F. BAND SELECTOR at 4.	Same as Step 1	4 5 6 6	Until a signal is heard. Maximum output Maximum output Repeat above steps for maximum gain.

R-F, MIXER, & OSCILLATOR ALIGNMENT

EQUIPMENT REQUIRED:

1. Output meter. The AC scale of a vacuum tube voltmeter (VTVM) or other suitable meter may be used.
2. Signal generator covering 600 KC to 54 MC. Provisions for a modulated signal should be available.

CONNECTING THE TEST EQUIPMENT:

1. The output meter should be connected between the 500 ohm speaker terminal and ground. The output of the receiver should be properly loaded by means of a speaker or dummy load. Speaker loading will enable the operator to monitor the signal and better alignment will result.
2. Connect the high side of the signal generator to antenna terminal "A1" through a 330 ohm carbon resistor. The jumper provided on the antenna terminal strip should be in place between "A2" and "G". Keep the output of the signal generator as low as possible at all times to prevent overloading of the high gain stages. Use just enough output to give a useable indication on the output meter. If the signal generator output is too high when coupled through the resistor, use a capacitor or place the hot lead from the generator near antenna terminal "A1". The ground side of the signal generator should be connected to the frame of the large main tuning capacitor. A modulated signal is used for all of the following alignment adjustments.

NOTE: An alignment tool made of polystyrene or similar material will be required. These adjustments may be made without removing the receiver from the cabinet. However, if the chassis is removed from the cabinet the bottom cover plate of the R.F., MIXER, and OSC. compartments must be in place.

The following adjustments are made with VOLUME, TONE, and SENSITIVITY controls fully clockwise, BFO switch OFF, CRYSTAL PHASING at ZERO, NOISE LIMITER switch at OFF, RECEPTION switch at NORMAL I.F., and BFO switch at OFF. Refer to Figs. 11 & 12 for location of all adjustments.

Step	Signal Generator Frequency (Mod.)	BAND SELECTOR Switch Setting	Band Spread Dial Setting	Main Tuning Dial Setting	Adjust	Remarks
1	1500 KC	1	100	1.5 MC	A	Until a signal is heard.
	1500 KC	1	100	1.5 MC	B	Maximum output
	1500 KC	1	100	1.5 MC	C	Maximum output
	600 KC	1	100	.60 MC	D	Until a signal is heard.
	1500 KC	1	100	1.5 MC	A	Maximum output
	1500 KC	1	100	1.5 MC	B	Maximum output
	1500 KC	1	100	1.5 MC	C	Maximum output
	600 KC	1	100	.60 MC	D	Maximum output
	1500 KC	1	100	1.5 MC	A, B & C	Maximum output
2	4 MC	2	100	4.0 MC	E	Until a signal is heard.
	4 MC	2	100	4.0 MC	F	Maximum output
	4 MC	2	100	4.0 MC	G	Maximum output
	4 MC	2	100	4.0 MC	E, F & G	Maximum output
3	12 MC	3	100	12. MC	H	Until a signal is heard.
	5.2 MC	3	100	5.2 MC	I	Until a signal is heard.
	12 MC	3	100	12. MC	H	Maximum output
	5.2 MC	3	100	5.2 MC	I	Maximum output
	12 MC	3	100	12. MC	H, J & K	Maximum output
4	30 MC	4	100	30 MC	L	Until a signal is heard.
	14 MC	4	100	14 MC	M	Until a signal is heard.
	14 MC	4	100	14 MC	N	Maximum output
	14 MC	4	100	14 MC	O	Maximum output
	30 MC	4	100	30 MC	L	Maximum output
	30 MC	4	100	30 MC	P	Maximum output
	30 MC	4	100	30 MC	Q	Maximum output
	14 MC	4	100	14 MC	M, N & O	Maximum output
	30 MC	4	100	30 MC	L, P & Q	Maximum output
5	54 MC	5	54 MC	100	R	Until a signal is heard.
	54 MC	5	54 MC	100	S	Maximum output
	54 MC	5	54 MC	100	T	Maximum output
	54 MC	5	54 MC	100	R, S & T	Maximum output

PERFORMANCE DATA FOR SERVICE ENGINEERS

MEASUREMENT CONDITIONS

- Modulation - 30% at 400 cycles
- Dummy Antenna:
- Standard RMA on bands 1 and 2.
- 300 ohm resistor on bands 3, 4 and 5.
- Output - 50 milliwatts into 500 ohms.
- Power Supply - 117 volts, 60 cycles.

AUDIO RESPONSE ± 5 db from 100 to 3000 cycles.

SIGNAL TO NOISE RATIO - Not less than 10 db with 2 microvolt input.

I-F AMPLIFIER GAIN (455 KC) & BANDWIDTH

Stage	Gain	6 db	60 db
2nd conv. (osc. working; receiver tuned to 3 MC)	15X	6 KC	15 KC
1st I-F amplifier	29X	6 KC	16 KC
2nd I-F amplifier	4.5X	6 KC	15 KC
3rd I-F amplifier	24X	20 KC	125 KC

OVERALL BANDWIDTHS

Frequency	6 db	60 db
2075 KC (NORMAL I.F.)	3.5 KC	14 KC
2075 KC (BROAD XTAL)	.7 KC	11 KC
1000 KC (NORMAL I.F.)	3.2 KC	13 KC

GENERAL PERFORMANCE

ANT., RF & OSC. STAGE GAIN

Band	Freq. (MC)	GENERAL PERFORMANCE		ANT., RF & OSC. STAGE GAIN		
		Sens. (uv)	Image Ratio	Ant.	RF	Osc. (Conv. Gain)
1	.6	13	24,000 X	3.4 X	2.9 X	14 X
	1.0	6.5	7,000 X	3.5 X	3.5 X	13 X
	1.5	5.3	1,800 X	3.6 X	3.5 X	12 X
2	1.8	1.5	28,000 X	4.7 X	3.2 X	18 X
	3.2	*	1,000 X	4.9 X	6.1 X	18 X
	4.0	*	300 X	4.7 X	7.2 X	16 X
3	5.2	2.4	8,800 X	1.9 X	7.1 X	10 X
	9.0	1.4	2,500 X	2.9 X	7.6 X	12 X
	12.0	*	570 X	3.3 X	7.7 X	12 X
4	14.0	*	1,500 X	1.3 X	8.0 X	12 X
	24.0	*	180 X	1.7 X	8.5 X	14 X
	30.0	1	100 X	1.7 X	8.1 X	9 X
5	48.0	1	36 X	1.8 X	6.6 X	13 X
	54.0	*	20 X	1.8 X	7.7 X	18 X

* Less than one microvolt.

Authorized
hallicrafters
 Service Center

communications
 equipment

92X1401

SERVICE OR OPERATING QUESTIONS - For further details regarding operation or servicing of the receiver, contact your dealer. Make no shipments directly to the factory as the factory does not accept the responsibility for unauthorized shipments. Factory type service is available at any **HALLICRAFTERS AUTHORIZED SERVICE CENTER**. For the location of the **SERVICE CENTER** nearest you; consult your dealer, telephone directory or look for the sign shown at the left.

The Hallicrafters Co. reserves the privilege of making revisions in current production of equipment and assumes no obligation to incorporate these revisions in earlier models.

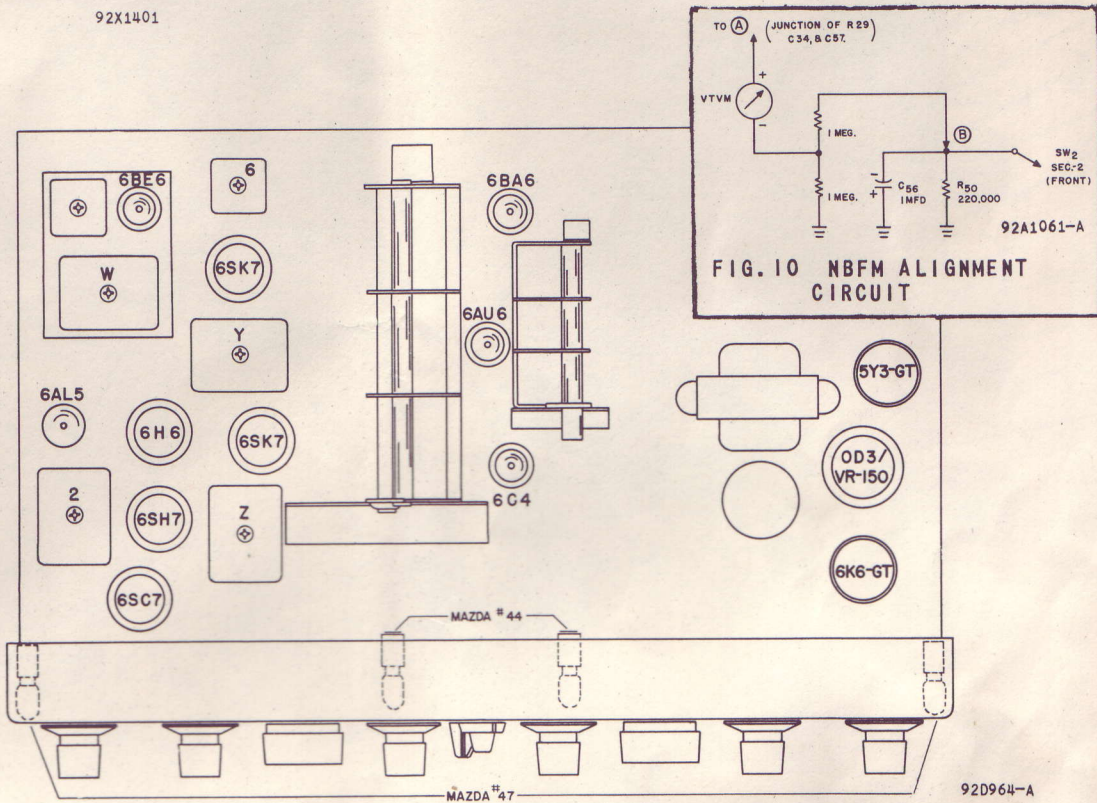

FIG. 11 TOP VIEW - LOCATION OF ALIGNMENT ADJUSTMENTS, TUBES AND DIAL LAMPS

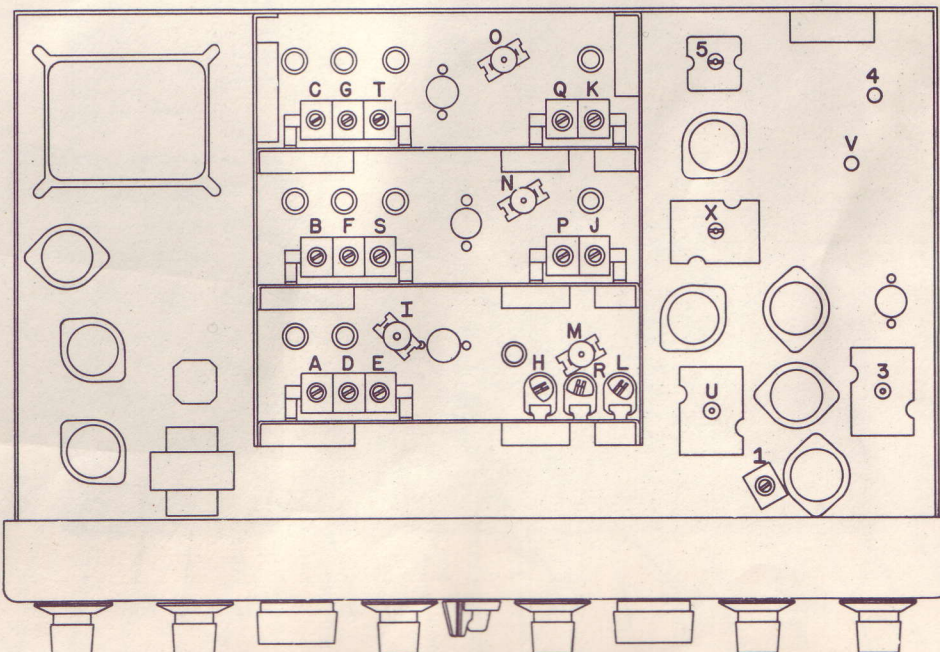

FIG. 12 BOTTOM VIEW - LOCATION OF ALIGNMENT ADJUSTMENTS

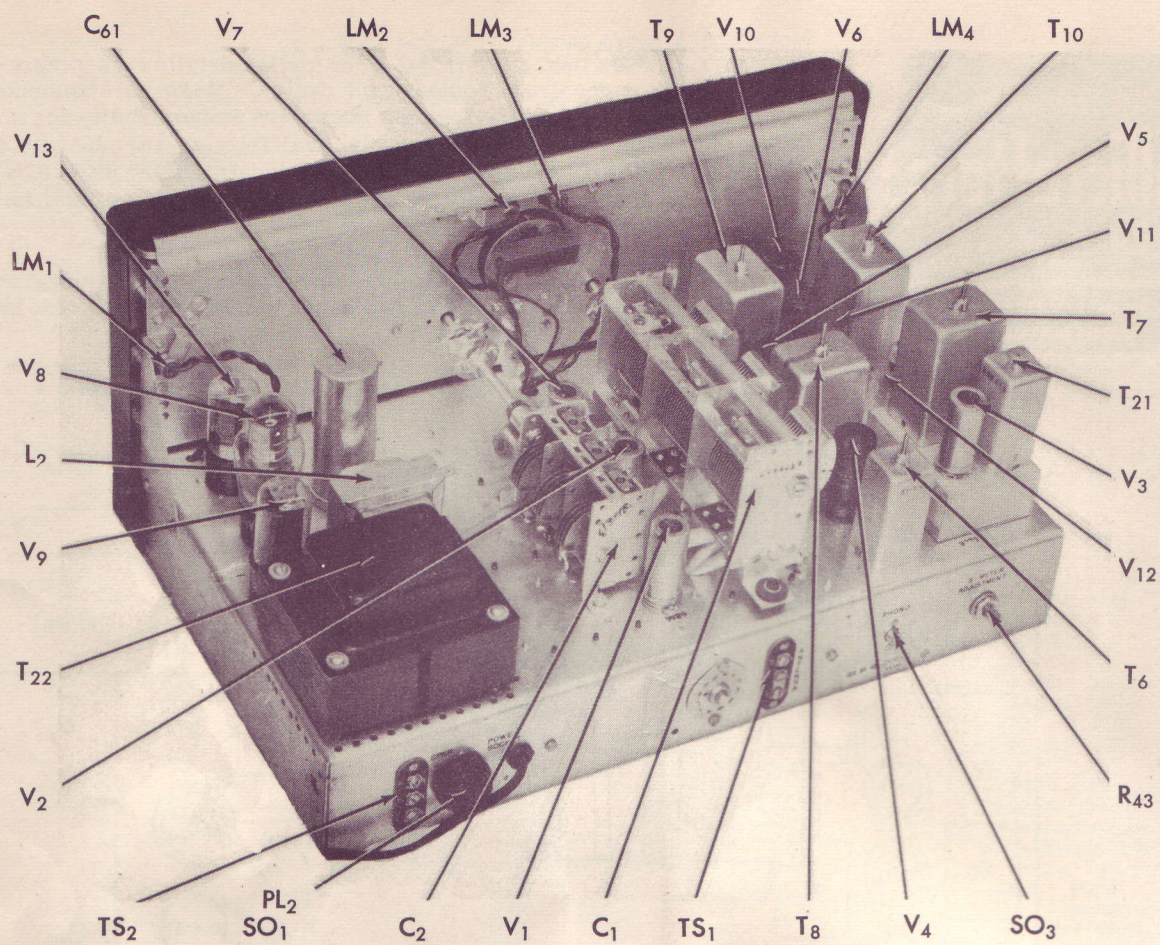

FIG. 13. TOP VIEW - COMPONENT LOCATION

92X966-A

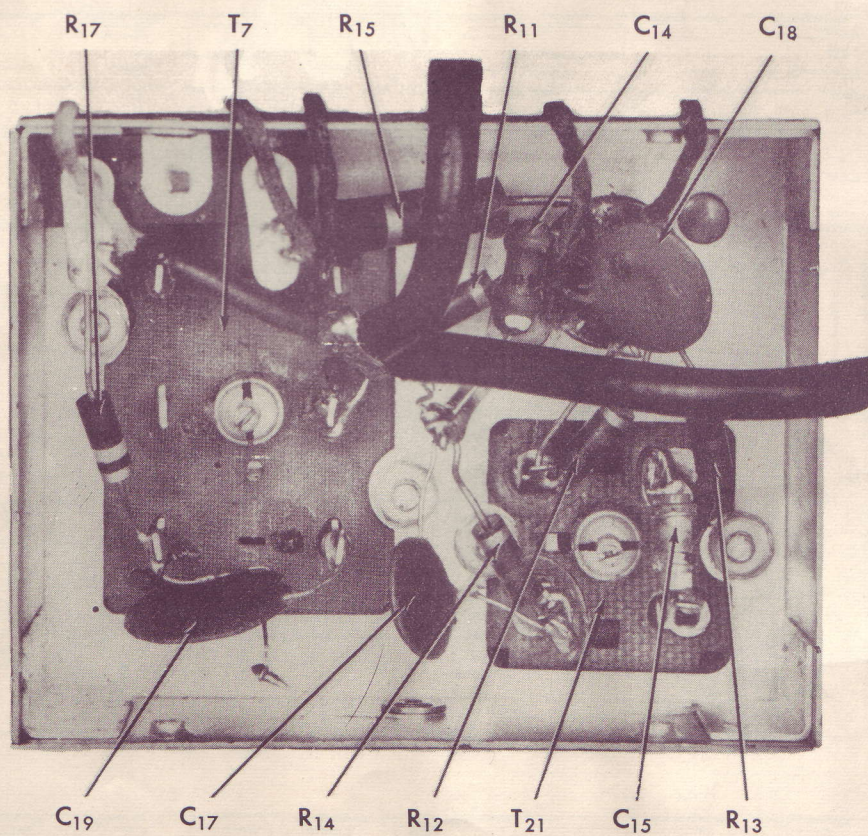

FIG. 14. BOTTOM VIEW OF 2ND CONVERTER UNIT - COMPONENT LOCATION

92X1075

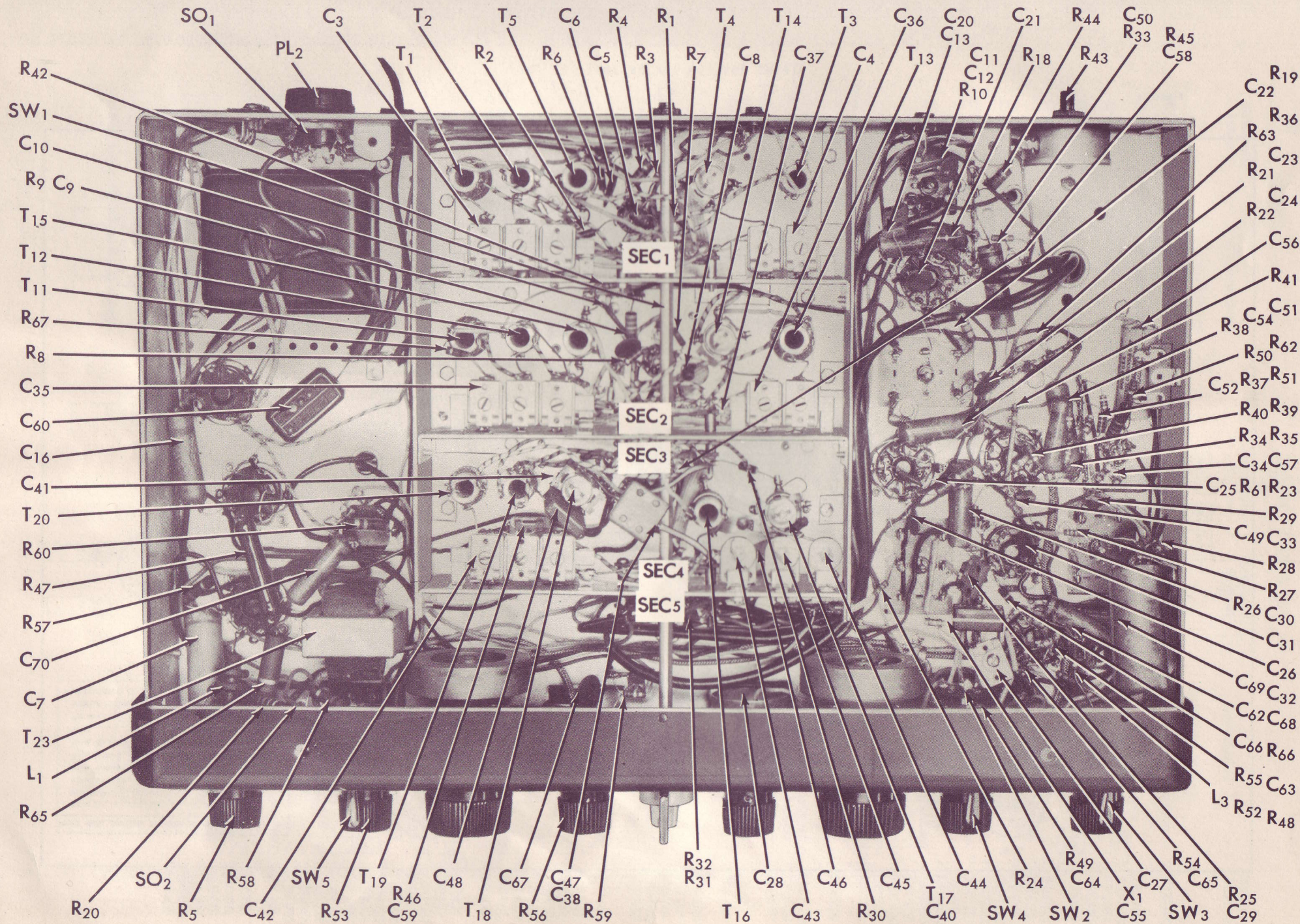
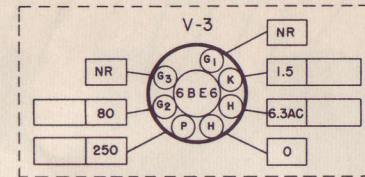
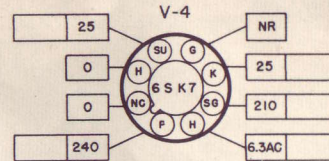
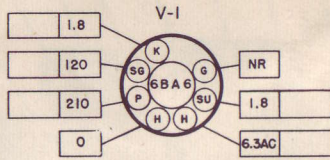

FIG. 15. BOTTOM VIEW - COMPONENT LOCATION

FRONT PANEL CONTROL SETTINGS UNLESS OTHERWISE NOTED

B.F.O.	-----	OFF
RECEPTION	-----	NOR. I.F.
NOISE LIMITER	-----	ON
MAIN TUNING	-----	LOW FREQ. END OF DIAL
BAND SPREAD	-----	LOW FREQ. END OF DIAL
BAND SELECTOR	-----	BAND 1
TO NE	-----	CCW
VOLUME	-----	CCW (SWITCH ON)
RECEIVE / STANDBY	-----	RECEIVE
SENSITIVITY	-----	CW



VOLTAGES SHOWN FOR V-3 WERE MEASURED WITH BANDSWITCH IN POSITIONS 3, 4 AND 5. VOLTAGE AT G₂ IS ZERO ON BANDS 1 AND 2.

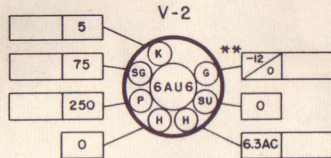

** NOTE - MAX./MIN. GRID VOLTAGE VARIES WITH SETTING OF MAIN TUNING GANG AND BANDSWITCH.

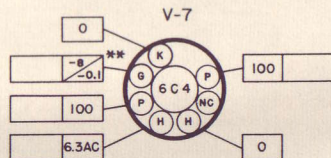
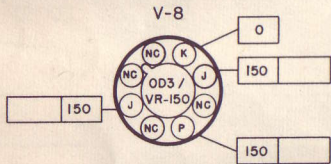
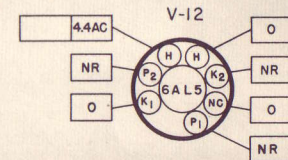
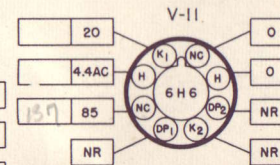
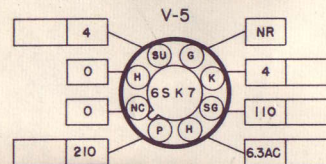
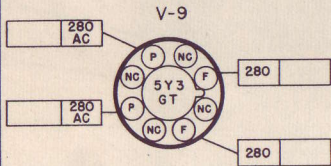

** NOTE - MAX./MIN. GRID VOLTAGE VARIES WITH SETTING OF MAIN TUNING GANG AND BANDSWITCH.

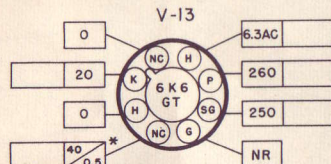
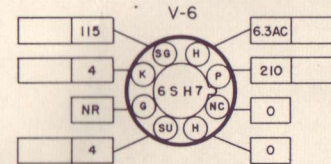

* SENSITIVITY CONTROL CCW/CW.

NOTES-

1. SOCKET VIEWS ARE BOTTOM VIEWS.
2. ALL VOLTAGES ARE MEASURED BETWEEN TUBE SOCKET TERMINALS AND GROUND WITH ZERO SIGNAL INPUT.
3. LINE VOLTAGE 117 V. AC.
4. ALL VOLTAGES SHOWN ARE DC UNLESS OTHERWISE SPECIFIED.
5. DC VOLTAGES SHOWN WERE MEASURED WITH AN ELECTRONIC VOLTMETER.
6. "NC"- NO CONNECTION, VOLTAGE SHOWN FOR THIS TERMINAL ONLY WHEN TERMINAL IS USED AS A TIE LUG.
7. "NR"- NOT READABLE, VOLTAGES MEASURED AT THESE TERMINALS GENERALLY MEANINGLESS.
8. "CW"- CLOCKWISE. "CCW"- COUNTER-CLOCKWISE.
9. SPACE PROVIDED FOR SERVICE METER READINGS.

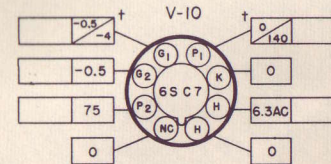

† B.F.O. SWITCH OFF/ON

FRONT PANEL

FIG. 16. TUBE SOCKET VOLTAGE CHART

SERVICE PARTS LIST

Schematic Symbol	Description	Hallicrafters Part Number	Schematic Symbol	Description	Hallicrafters Part Number
CAPACITORS			RESISTORS (Cont.)		
C-1	Capacitor, MAIN TUNING (3 section)	48D209	R-10,24,28,42	3300 ohms 1/2 watt, carbon	23X20X332K
C-2	Capacitor, BANDSPREAD (3 section)	48C210	R-11	220 ohms 1/2 watt, carbon	23X20X221K
C-3	Trimmer ass'y, antenna stage (Bands 1, 2 & 5)	44B381	R-12,45	22,000 ohms 1/2 watt, carbon	23X20X223K
C-4	Trimmer ass'y, antenna stage (Bands 3 & 4)	44B379	R-14,48	150 ohms 1/2 watt, carbon	23X20X151K
C-5,33,34,52,57,63,68	220 mmf. 500 V., ceramic	47B20221K5	**R-15,46,60	10,000 ohms 1 watt, carbon	23X30X103K
C-6,10,19,67	Dual 4000 mmf. 450 V., ceramic	47A218	R-17,21,25,49,52,55	100,000 ohms 1/2 watt, carbon	23X20X104K
C-7	.25 mfd. 200 V., tubular	46AT254J	R-18,26	270 ohms 1/2 watt, carbon	23X20X271K
**C-8,14,38,41,58	100 mmf. 500 V., ceramic	47X20UJ101K	R-19,27	33,000 ohms 1/2 watt, carbon	23X20X333K
C-9,12,17,18,21,22,23,25,26,31,64,65	5000 mmf. 450 V., ceramic	47A168	R-20	47,000 ohms 1 watt, carbon	23X30X473K
**C-11,13	300 mmf. 500 V., mica	47X20B301J	R-22	1000 ohms 1/2 watt, carbon	23X20X102M
**C-15	47 mmf. 500 V., ceramic	47X20UK470K	R-23	6800 ohms 1/2 watt, carbon	23X20X682K
C-16,20,24,30,50	.05 mfd. 600 V., tubular	46AY503J	R-29	56,000 ohms 1/2 watt, carbon	23X20X563K
C-27	Trimmer, adjustable	44A047	R-31	680 ohms 1/2 watt, carbon	23X20X681K
C-28	Capacitor, variable; CRYSTAL PHASING	48A182	R-32,33	2700 ohms 1/2 watt, carbon	23X20X272K
**C-29	33 mmf. 500 V., mica	47X20A330K	R-34,35,40	470,000 ohms 1/2 watt, carbon	23X20X474K
C-32	.25 mfd. 600 V., tubular	46AX254J	R-36	180,000 ohms 1/2 watt, carbon	23X20X184K
C-35	Trimmer ass'y, mixer stage (Bands 1, 2 & 5)	44B382	R-37	82,000 ohms 1/2 watt, carbon	23X20X823K
C-36	Trimmer ass'y, mixer stage (Bands 3 & 4)	44B380	R-38,50,59	220,000 ohms 1/2 watt, carbon	23X20X224K
**C-37	15 mmf. 500 V., ceramic	47X20UJ150K	R-43	500 ohms, variable; "S" METER ADJUSTMENT	25C022
**C-40,49	25 mmf. 500 V., ceramic	47X20UK250K	R-43	200 ohms, variable; "S" METER ADJUSTMENT	25B714
C-42	Trimmer ass'y, oscillator stage (Bands 1 & 2)	44B383	R-47	2500 ohms 10 watts, wirewound	24BG252D
C-43,44,45	Trimmer ass'y, oscillator stage (Bands 3, 4, & 5)	44A378	R-51	39,000 ohms 1/2 watt, carbon	23X20X393K
**C-46	2200 mmf. 500 V., mica	47X30D222J	R-53	500,000 ohms, variable; VOLUME control	25B604
**C-47	910 mmf. 500 V., mica	47X30D911J	R-54	15 megohms 1/2 watt, carbon	23X20X156K
**C-48	1500 mmf. 500 V., mica	47X30D152G	R-56	500,000 ohms, variable; TONE control	25B589
C-51	.1 mfd. 200 V., tubular	46AU104J	R-57,58	560 ohms 1 watt, carbon	23X30X561K
C-54	.02 mfd. 200 V., tubular	46AU203J	R-61,62	6.8 ohms 1 watt, carbon	23X30X068K
**C-55	10 mmf. 500 V., ceramic	47X20UK100K	R-63	27,000 ohms 1/2 watt, carbon	23X20X273K
C-56	1 mfd. 50 V., electrolytic	45A163	R-65	47,000 ohms 2 watts, carbon	23X40X473K
**C-59	Capacitor, temperature compensator	44A158	R-67	100 ohms 1/2 watt, carbon	23X20X101K
C-60	.01 mfd. 600 V., molded tubular	46X35X103M	TRANSFORMERS AND COILS		
C-61	60-20 mfd. 450 V., & 20 mfd. 400 V.; electrolytic	45B113	T-1	Coil, antenna; band 1	51B1088
C-62,70	.01 mfd. 600 V., tubular	46AY103J	T-2	Coil, antenna; band 2	51B1089
C-66	1 mmf. 450 V., ceramic	47A160-2	T-3	Coil, antenna; band 3	51B1090
**C-69	470 mmf. 500 V., mica	47X20B471J	T-4	Coil, antenna; band 4	51B1091
			T-5	Coil, antenna; band 5	51B1092
			T-6	Transformer, 1st IF (2.075 MC)	50C414
			T-7,8	Transformer, 1st and 2nd IF (455 KC)	50C416
			T-9	Transformer, 3rd IF (455 KC)	50C415
			T-10	Transformer, FM detector	50C418
			T-11	Coil, RF; band 1	51B1093
			T-12	Coil, RF; band 2	51B1094
			T-13	Coil, RF; band 3	51B1095
			T-14	Coil, RF; band 4	51B1096
			T-15	Coil, RF; band 5	51B1097
			T-16	Coil, oscillator; band 5	51B1160
			T-17	Coil, oscillator; band 4	51B1101
			T-18	Coil, oscillator; band 3	51B1100
			T-19	Coil, oscillator; band 2	51B1099
			T-20	Coil, oscillator; band 1	51B1098
			T-21	Coil, oscillator; 2nd converter (bands 3, 4 and 5)	50C448
			T-22	Transformer, power (SX-71)	52C174
			T-22	Transformer, power (SX-71U)	52C175
			T-23	Transformer, audio output	55B120
			L-1	Choke, RF	53A107
			L-2	Choke, filter	56B107
			L-3	Coil, BFO	54B039

** Use exact replacement part only.

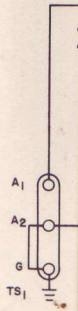

SW1
SEC-2
(REAR)

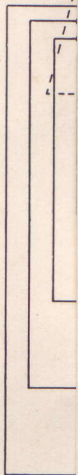

BAND
P

V.
V.
T.
T.C.

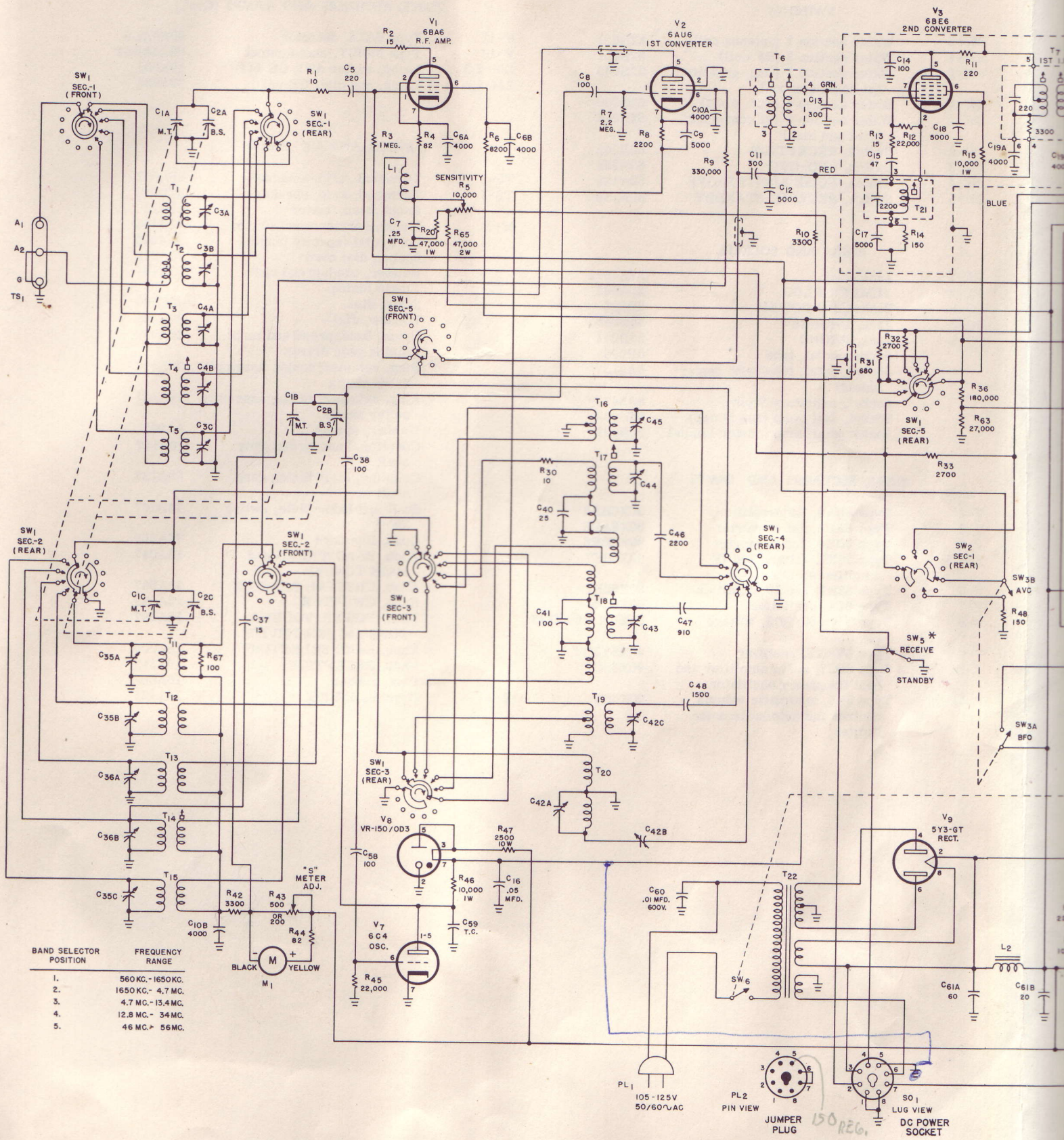

BAND SELECTOR POSITION	FREQUENCY RANGE
1.	560 KC. - 1650 KC.
2.	1650 KC. - 4.7 MC.
3.	4.7 MC. - 13.4 MC.
4.	12.8 MC. - 34 MC.
5.	46 MC. - 56 MC.

VALUES AND TOLERANCES SHOWN ARE NOMINAL AND VARIATIONS MAY BE FOUND. IT IS RECOMMENDED THAT THE VALUE OF ANY REPLACEMENT CORRESPOND TO THE NOMINAL VALUE OF THE PART BEING REPLACED.

MODELS SX-71 & SX-71U RUN 4

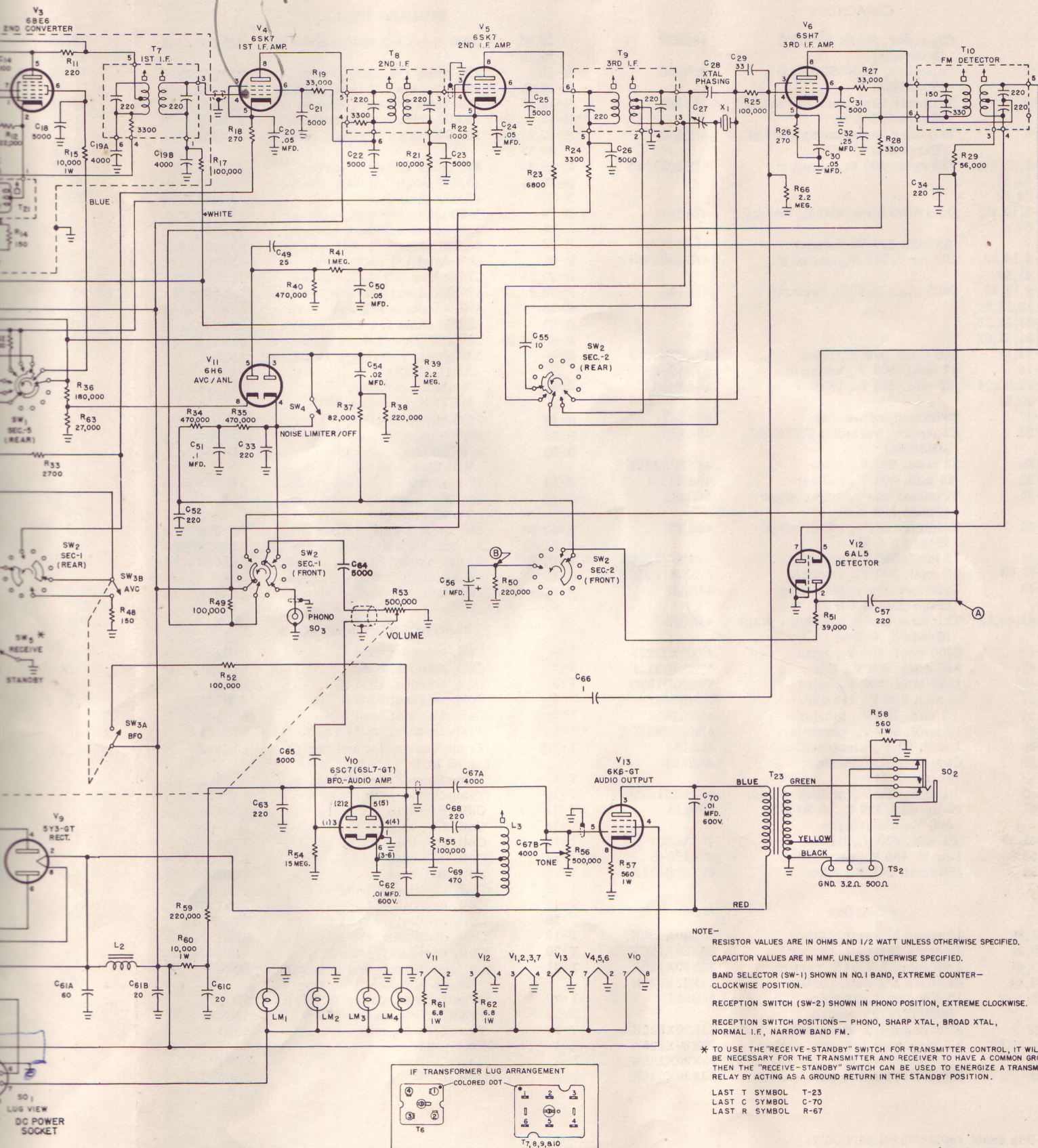

FIG. 17. SCHEMATIC DIAGRAM

Warranty

"The Hallicrafter's Company warrants each new radio product manufactured by it to be free from defective material and workmanship and agrees to remedy any such defect or to furnish a new part in exchange for any part of any unit of its manufacture which under normal installation, use and service discloses such defect, provided the unit is delivered by the owner to our authorized radio dealer, wholesaler, from whom purchased, or, authorized service center, intact, for examination, with all transportation charges prepaid within ninety days from the date of sale to original purchaser and provided that such examination discloses in our judgment that it is thus defective.

This warranty does not extend to any of our radio products which have been subjected to misuse, neglect, accident, incorrect wiring not our own, improper installation, or to use in violation of instructions furnished by us, nor extend to units which have been repaired or altered outside of our factory or authorized service center, nor to cases where the serial number thereof has been removed, defaced or changed, nor to accessories used therewith not of our own manufacture.

Any part of a unit approved for remedy or exchange hereunder will be remedied or exchanged by the authorized radio dealer or wholesaler without charge to the owner.

This warranty is in lieu of all other warranties expressed or implied and no representative or person is authorized to assume for us any other liability in connection with the sale of our radio products."

Form No. 94X622

the Hallicrafters co.

Dear Jerry:

I have modified the power socket somewhat. All the changes are shown on the schematic and on top of page 4.

I also have a crystal oscillator circuit on a small chassis packed near the top so be carefull pulling out the packing. I didn't remove the tubes I took your advise. If you will get a 100KC crystal to use with this it would give you band edge markers and make tunning more reliable. I don't have a crystal or would include it. I used it to locate a mars frequency that was hard to locate. The oscilator was attached to the top along the back edge. It has a power type plug attached to it so just remove the plug that is in the power socket and install this one.

If you want to remote control the transmitter or reciever there is instructions on page 5 above Operations. These wires can be brought out of this power plug very easily.

I am enclosing an envelope from JAN Crystals. If you would send them a post card and ask for their latest crystal catalogue you can get fairly good buys on crystals of all kinds. I believe they get \$4.50 for the 100 Hz crystal but their novice and amateur crystals are \$1.50 each or 4 for \$5.

I have added an RCA type coaxial connector along side of the regular antenna posts. If you want this can be used for 52 or 72 ohm coaxial lead. The instruction book tells about connecting up for different antennas.

You mentioned that you were going to put up a dipole for the various bands. The November QST has an article on an antenna system you might be interested in.

I can not think of anything else at the moment that I should pass on. I wanted to get this in with the instruction book.

I hope that this receiver works well for you and that it helps you have many good contacts on the air.