

THE HAMMARLUND

HQ-145A

&

HQ-145AX



HAMMARLUND

THE HAMMARLUND

HQ-145A

&

HQ-145AX

HAMMARLUND MANUFACTURING COMPANY
53 WEST 23RD STREET
NEW YORK, N.Y. 10010

9001-06-00002



Figure 1. The HQ-145A Communications Receiver

TUBE COMPONENT

<u>SYMBOL</u>	<u>TYPE</u>	<u>TUBE</u>	<u>FUNCTION</u>
V1	6BZ6	Pentode	RF Amplifier
V2	6BE6	Pentagrid Converter	1st Mixer
V3	6BE6	Pentagrid Converter	Converter or 455 Kcs IF Amplifier
V4	6BA6	Pentode	455 Kcs IF Amplifier and SSB Detector Driver
V5	6BA6	Pentode	455 Kcs IF Amplifier
V6	6AL5	Double Diode	AM and SSB Detector, Noise Limiter
V7	12AX7	Double Triode	455 Kcs BFO, Audio Amplifier
V8	6AQ5	Pentode	Audio Power Output
V9	6C4	Triode	High Frequency Oscillator
V10	OB2	Gas Filled Diode	Voltage Regulator

INTRODUCTION

The Hammarlund HQ-145A multi-purpose continuous coverage communications receiver incorporates many new circuit innovations in addition to the well known Hammarlund crystal filter and series noise limiter circuits. It will provide years of top performance with a minimum of maintenance.

The HQ-145A receiver has a self-contained power supply operating from a 117 volt 50/60 cps source or 220/230 volt, 50/60 cps source. The HQ-145AC incorporates a telechron automatic clock timer in its design. The HQ-145AX version provides 11 fixed-frequency crystal controlled channels. Six of the crystals are easily interchangeable from the front panel--the balance are located within the cabinet but are readily accessible from the cabinet top.

The HQ-145A is an eleven tube continuous coverage (540 Kcs to 30 Mcs) superheterodyne receiver which employs the double conversion process on the 10 to 30 Mcs range and on the 20 Meter amateur bandspread position. The special bandspread ranges of 21.0 to 21.6 Mcs and 28.0 to 30.0 Mcs are included in the double conversion process.

Electrical bandspread tuning is provided with direct calibration every 10 Kcs on the 15 meter band and every 50 Kcs on the 10 meter band. In addition an arbitrary bandspread logging scale is provided for use throughout the tuning range of the receiver.

The 100 Kcs crystal calibrator (optional accessory) provides marker signals at every 100 Kcs on all bands for checking dial calibration accuracy. A tuned RF stage with the addition of an antenna trimmer assures maximum sensitivity and a high signal to noise ratio for outstanding reception of weak and distant signals. A manual sensitivity (RF gain) control prevents the receiver from overloading on strong signals.

The well known Hammarlund crystal filter provides optimum selectivity for high rejection of closely spaced interfering signals.

The HQ-145A communications receiver is equipped with an unusually stable beat frequency oscillator which provides the operator of the receiver with a range of audio tones for excellent reception of single side band (SSB) signals as well as code (CW) signals.

One special feature of the HQ-145A receiver is a "razor sharp" adjustable slot filter to eliminate co-channel interference. A single knob controls the position of the "hole" in the IF passband and provides up to 40 db attenuation of the unwanted signals over a range of 10 Kcs. In addition, the slot depth control may be used to obtain an additional 20 db rejection at any single frequency.

Accurate reports of signal strength on AM reception are obtained with the aid of the "S" meter for that "on the nose" tuning. A send-receive switch is provided to silence the receiver while transmitting.

The receiver possesses the Auto Response feature which automatically narrows and widens the frequency range of the audio output, according to the gain required. This feature permits higher fidelity reception on stronger signals, while providing the sharp cut-off required in receiving communications under adverse conditions. A second advantage of the Hammarlund Auto-Response is the rapid damping of the audio power in the speaker voice coil which greatly minimizes undesirable speaker "hangover". The receiver may be used with either speaker or headphones. A-c hum is made inaudible by means of adequate power supply filtering.

Large comfortable controls in logical groupings are provided for the greatest of operating ease. The new futuristic front panel is clearly marked to permit full attention to the operation at hand.

The HQ-145A was designed with you in mind. You will have many hours of pleasure in operating this truly fine communications instrument.

The HQ-145A Series differs from the 145 Series in the following respects:

1. The power supply is designed for 115/230 volt 50/60 cycle AC operation.

2. A new accessory socket plus a systems socket has been added. The accessory socket may be used to power most 6 and 2 meter converters. The systems socket will be found convenient when the HQ-145A series of receiver is employed in conjunction with a transmitter since all of the necessary VOX anti trip and/or relay connections are available from this socket. This also provides a rapid disconnect without the need of tools once the installation has been completed properly. A Coordination Cable is available for use with the HQ-145A series of receivers designed primarily for use with the HX-50 Hammarlund transmitter but useable with other transmitters as well. This is part #PL39286-G1 at \$8.50.

3. 3.2 ohms and 500 ohms output terminations are now provided for voice coil or line operation. The 500 ohm line termination will be found very advantageous for phone patch and improved anti trip operation of most VOX circuits.

4. The 5U4G tube formerly used in the HQ-145X has now been replaced with two (2) silicon diode rectifiers thus providing cooler operation and better regulation from the power supply.

5. The HQ-145AX series of receivers provides an 11 position fixed frequency crystal oscillator assembly which is factory installed in the panel space provided for the 24 hour clock timer. The knob on this assembly allows selection of normal variable frequency tuning or any one of eleven fixed frequencies crystal controlled. Six crystals are mounted on the front plate of the oscillator assembly and may be changed quite readily to shift frequency. The remaining 5 crystals are mounted behind the front panel on the oscillator box and may be changed by lifting the top cover of the cabinet. It is intended that the five inside crystals will be for commonly used channels not subject to being changed very often.

The use of the crystal controlled oscillator will permit the highly stable reception of signals on the eleven channels selected. The only operation required beside turning the selector switch to the desired crystal position is to turn the band switch to the required position and tune the main dial to the approximate frequency rocking the knob finally for maximum "S" meter indication.

In order to ensure proper operation the crystals should be ordered from your local authorized Hammarlund distributor.

The oscillator or actual crystal frequency for a given signal frequency shall be determined from the following:

<u>SIGNAL FREQUENCY</u> <u>RANGE mc</u>	<u>ADD IF -----</u> <u>FREQUENCY mc</u>	<u>MODE OF</u> <u>OPERATION</u>
.54 to 1.60 mc	.455000	Fundamental
1.60 to 4.0 mc	.455000	Fundamental
4.0 to 10.0 mc	.455000	Fundamental
10.000 to 20.000 mc	3.035	Fundamental
20.000 to 30.000 mc	3.35	2nd Harmonic

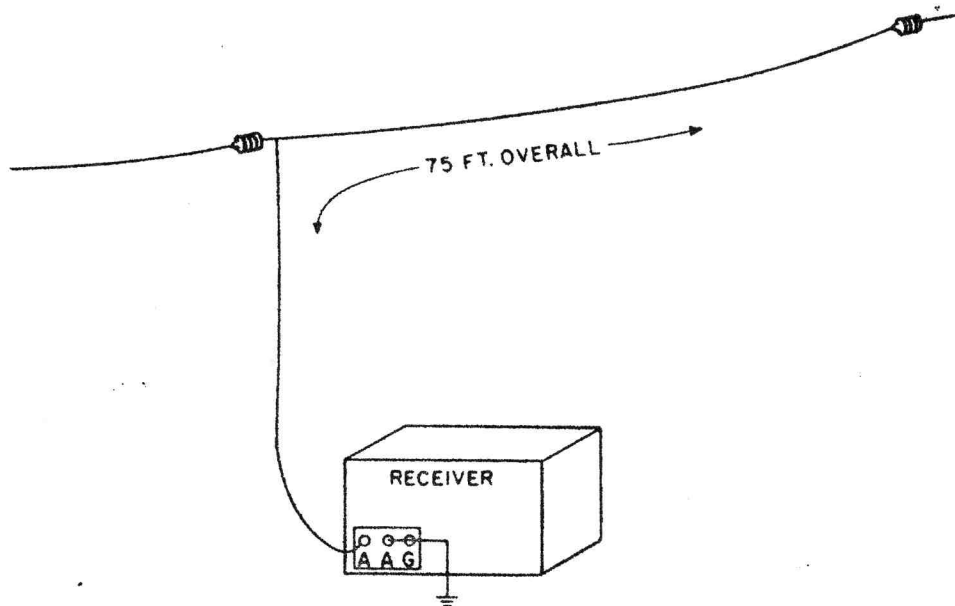

Figure 2. Installation of Single Wire Antenna

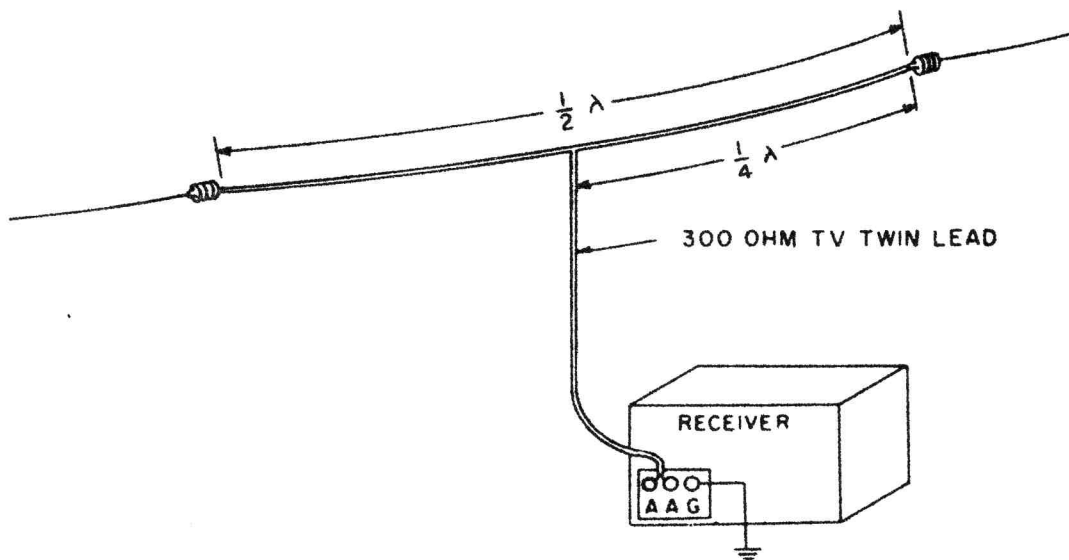

Figure 3. Installation of Folded Dipole Antenna

INSTALLATION

UNPACKING

Unpack the receiver carefully. Make sure the tubes, associated tube shields and pilot lamps are in place.

SPEAKER CONNECTION

Connect a 3.2 ohm permanent magnet speaker (Hammarlund S-100 or S-200 Speaker) to the two terminals marked GND and 3.2 ohms on the rear of the chassis. (Note Figure 4.) For best performance do not place speaker on top of receiver cabinet.

POWER CONNECTIONS

Before inserting attachment plug into power outlet, make certain power source is of proper voltage and frequency. (Refer to paragraph two of INTRODUCTION.)

INSTALLING ANTENNA

The HQ-145A is designed to operate with a single wire or a balanced type antenna. The front panel antenna trimmer control (Figure 5) permits a good match to most antenna systems of 50 to 600 ohms.

For general coverage, single wire antenna of 20 to 50 feet length will provide surprisingly good reception. A long single wire outdoor antenna, such as shown in Figure 2, will generally provide entirely satisfactory performance. This wire may be 50 to 150 feet long.

For best reception, the antenna should be isolated as much as possible from neighboring objects and at right angles to power lines or busy highways so as to minimize possible interference pickup.

Optimum performance on a particular amateur band or other narrow tuning range will be obtained by using a tuned half-wave dipole or folded dipole fed with 300 ohm transmission line or other suitable lead-in, as shown in Figure 3.

To tune the one-half wave length dipole, the following formula for the length of the antenna may be used:

$$\text{Length (feet)} = \frac{463}{\text{Freq. (MCS)}}$$

Each half (1/4 wave length) is half the length found from the above formula.

A good ground, although not always necessary, will generally aid in reception and reduce stray line hum. Reversal of polarity of power cord plug may possibly further reduce line hum in some locations.

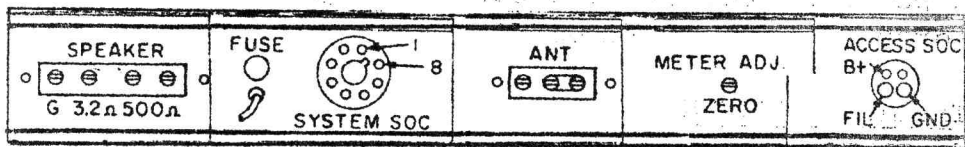

Figure 4. Connection Points at Rear of Chassis

GENERAL OPERATING INSTRUCTIONS

MAIN TUNING

The Main Tuning dial provides continuous coverage throughout the entire range of the receiver. In order for the Main Dial calibration to be accurate, the bandspread dial scale must be set at the indicated vertical marking which is located at the extreme clockwise end of its dial scale.

BAND SPREAD TUNING

The Band Spread Dial scale provides expanded dial scale coverage on the 80, 40, 20, 15 and 10 meter amateur bands. To use the Band Spread Dial, set the Main Dial scale to the highest indicated frequency of the amateur band in which operation is desired. The amateur bands are prominently shown on the Main Dial scale by means of the boxed off areas.

20 METER BAND SPREAD POSITION

A special 20 Meter Band Spread position is incorporated in the Tuning Range switch to provide the optimum dial scale spread on this band. To obtain the proper dial calibration on the 20 Meter bandspread dial, the Tuning Range switch must indicate 20 BS. The adjustment of the Main Tuning dial for bandspread operation is the same as previously mentioned. (The BS dial calibration is inaccurate on the 15 and 10 Meter bands when the Tuning Range switch indicates 20 BS).

100 KCS CRYSTAL CALIBRATOR (OPTIONAL ACCESSORY)

The 100 Kcs crystal calibrator provides 100 Kcs check points for precise calibration throughout the range covered by the receiver. The 100 Kcs crystal controlled oscillator has been set at the factory with sufficient accuracy for all practical purposes.

For dial calibration checking, the Send-Receive-CW/SSB-CALIBRATE switch is set to CAL position and all other controls should be set as listed under Code or SSB Reception.

The receiver is adjusted with the Band Spread CAL Set line aligned to the vertical marker and should be reasonably correct. The Cal Set knob is used to accurately reset the B.S. dial indicator line if it is found to be slightly off calibration at any area on the dial where precise calibration is desired.

SUGGESTED TUNING PROCEDURE

First set the bandspread dial at the high frequency end of the particular amateur band. Next set the main tuning dial to the high frequency end of the band. If a 100 Kcs crystal calibrator is available, the Main tuning dial should be carefully adjusted, plus or minus the high frequency band edge marker until the 100 Kcs calibrator is heard. Care must be taken that the proper 100 Kcs marker is employed in order to prevent setting the main tuning dial 100 Kcs higher or lower than the band edge. Next rotate the bandspread dial to the 100 Kcs marker nearest to the center of the bandspread tuning range. It will undoubtedly be found that upon doing this, the 100 Kcs marker will be plus or minus of the exact frequency. The bandspread dial is therefore set to the exact 100 Kcs marking, and the main tuning dial is then very carefully adjusted until whatever error existed in the bandspread dial reading has been corrected. Once this condition has been obtained, the main tuning dial should be left alone and all tuning of the amateur bands accomplished with the bandspread tuning dial. Using this procedure of setting the bandspread dial near the center of its tuning range will halve the frequency error that may result when either band edge alignment is employed.

In the event that the 100 Kcs crystal calibrator is not available, a signal of known frequency, such as harmonics from the crystal oscillator in your transmitter, should be set up accurately on the BANDSPREAD tuning dial and the MAIN tuning dial rotated very carefully, plus or minus, from the high frequency band edge marker until the signal of known frequency reads correctly on the bandspread dial. For best accuracy of bandspread dial calibration, the known frequency should preferably be near the center of the bandspread dial tuning range, since, here again, this will result in halving the possible error that may result by setting up the bandspread dial to a known frequency at or near either of the band edges.

Without a 100 Kcs crystal calibrator or a known frequency, setting up the main tuning dial to the high frequency band edge marker may result in the bandspread tuning dial being off by as much as 100 Kcs or more. If the above procedure is followed, the bandspread tuning dial will usually read to within approximately 15 Kcs or better of the exact frequency.

TELECHRON AUTOMATIC TIMER

If your receiver is equipped with the built-in Telechron Automatic Clock-Timer, the following instructions should be noted:

Every radio-frequency device is stable only at pre-determined operating temperatures. In order to eliminate waiting for the receiver to warmup to operating temperature, the Telechron Timer automatically turns on the receiver ahead of anticipated operating time. This is accomplished by setting the hand of the timer (small knob at rear of receiver) to approximately one-half hour before operating time. The front panel control under Timer is then set to "Auto" position. The function switch is set to REC. The receiver is then automatically turned on at the desired time.

The clock hands are set by the rear knob. "Push in" and turn the knob to set the switch timing hand and "pull out" and turn the knob to set the clock hands. The front switch is set to AUTO and the function switch is set to REC when it is desired to use the automatic clock switch for pre-warming the receiver before operation or for use as an alarm to turn the receiver on to a pre-tuned station. To use the function switch normally, the clock switch should be left in the ON position.

The clock will continue to run as long as the receiver line cord is connected to the power outlet, and is extremely useful for checking sign-in periods and schedules.

If your receiver is not equipped with the Telechron Automatic Clock-Timer, and you would care to have the accessory added, the Clock Kit, with full installation instructions, may be purchased from your local Hammarlund dealer.

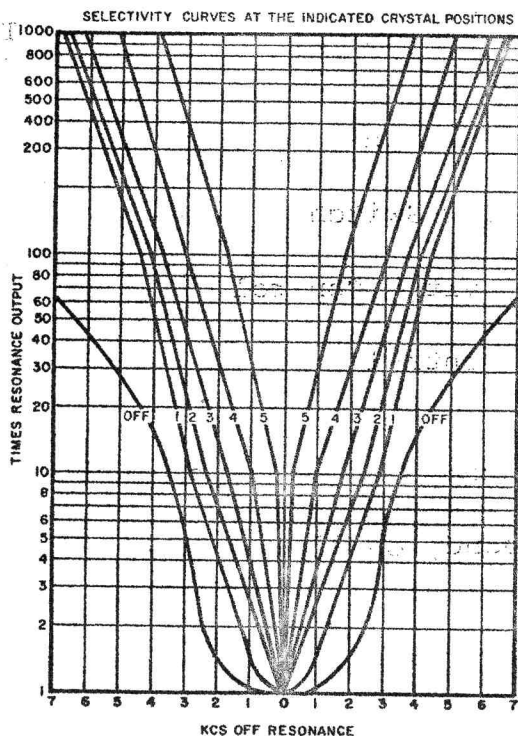

Figure 5. Selectivity Curves

OPERATION

AM RECEPTION

For AM reception the position of the controls nominally should be as follows:

Send-Receive-CW/SSB-Cal Switch	Receive
Selectivity Switch	* Off
Crystal Phasing	Triangular Marker
Slot Frequency	*** Clockwise
Slot Depth	**** See detailed instructions for use of slot filter
Main Tuning Control	Tune for the highest "S" Meter reading
Band Spread Control	Extreme Clockwise marking
Tuning Range Switch	Set to desired frequency range
Antenna Trimmer	Tune for the highest "S" Meter reading
AVC ON-OFF Switch	ON
Noise Limiter Switch	OFF
RF (Sensitivity) Control	** Fully Clockwise
AF (Gain) Control	***** Adjust to desired level
Timer Switch	ON
Beat Frequency Oscillator Control	Triangular Marker

* To obtain maximum fidelity in AM Reception, the widest bandwidth is normally used. However, under conditions of severe interference from spurious signals or atmospheric noise, the bandwidth is reduced to improve intelligibility although some sacrifice of fidelity results. Adjust crystal selectivity to suit reception conditions.

** For normal AM reception, the RF gain control is rotated fully clockwise. The "S" meter calibration holds only when the Manual-AVC switch is on AVC. In the presence of extremely strong signals, the RF (Sensitivity) Control may be reduced to limit meter swing.

*** The Slot Frequency control provides an extremely sharp adjustable slot or hole in the selectivity curve (See Figure 7). It is normally located outside of the passband of the 455 Kcs IF Amplifier system. It is brought into the passband for the purpose of eliminating interference from heterodyne signals on AM and monkey chatter on SSB. On CW Reception, the Slot Filter will materially aid in reducing or eliminating adjacent or co-channel interference.

CAUTION

WHEN TUNING THE RECEIVER ACROSS ANY BAND,
MAKE CERTAIN THAT THE SLOT FREQUENCY CONTROL
IS AT THE 5 KCS POSITION NOT ON "O".

**** The Slot Depth control is actually a very gradual vernier adjustment. In view of this its effect will not be very noticeable unless the proper procedure is employed. The suggested procedure is as follows:

Tune in a broadcast signal on the broadcast band or any other strong constant carrier of similar nature. Whenever the receiver is being tuned for normal reception be sure to first rotate the Slot Frequency control to the extreme clockwise or counter clockwise position. In other words, never leave the Slot Frequency control at or near the zero setting. If this procedure is not followed it is obvious that the center of the passband will be slotted out, some cases this being made quite obvious by producing 2 spot tuning or 2 peak "S" meter readings.

After tuning in the constant carrier, peaking the "S" meter, and taking the above precautions, rotate the Slot Frequency control. It will be noticed that upon approaching the zero setting, the "S" meter reading will be affected. A very definite null or minimum "S" meter reading will be obtained with the Slot Frequency control adjusted at or near zero. Observe this "S" meter reading.

With the Slot Frequency control set at the minimum "S" meter reading position, the Slot Depth control should be rotated very slowly throughout its range, observing the "S" meter. It will be found that at one particular spot throughout the range of the Slot Depth control a further reduction in the "S" meter reading will be obtained. A very slight readjustment of the Slot Frequency may now result in a further reduction of the "S" meter reading. Once this setting has been obtained, the Slot Depth control may be left permanently in this position, and all future Slot Filter adjustments made by the Slot Frequency control only. A periodic check of the Slot Depth control setting may be advisable.

***** A feature of the audio system is the variable negative feedback employed. Maximum feedback is provided at low settings of the Audio Gain Control for maximum quality reception of strong signals. As the Audio Gain Control is increased, the feedback decreases to provide additional selectivity by the audio system for reception of weak signals. This results in an increased signal to noise ratio. A further advantage is the critical damping of the speaker for the elimination of speaker "hangover". This upgrades the reception of speech and decreases receiver output noise. Another advantage is the reduction of distortion at low settings of the Audio Gain Control.

CODE OR SINGLE SIDEBAND RECEPTION

For CW Code reception the position of controls nominally should be as follows:

Send-Receive-CW/SSB-Cal Switch	CW/SSB
Selectivity	* OFF
Crystal Phasing	Triangular Marking
Slot Frequency	Clockwise
Slot Depth	See AM Rec.
Main Tuning Control	Tune for loudest signal
Band Spread Control	Tune for loudest signal, if used
Tuning Range Switch	Set to desired frequency range

Antenna Trimmer	Tune for the loudest signal
AVC ON-OFF Switch	OFF
Noise Limiter Switch	OFF
RF (Sensitivity) Control	Adjust to desired output level
AF (Gain) Control	3/4 Clockwise
Timer Switch	ON
Beat Frequency Oscillator	***Tune signal to zero beat with knob pointing to triangular marking, then turn off zero beat in either direction for desired tone on CW or best intelligibility on single sidebands reception

* Under conditions of severe interference, increase the selectivity of the receiver by turning knob to a higher position.

*** When a Single Sideband signal is received, the CW Pitch knob must be turned in the correct direction so that the re-inserted carrier (provided by the BFO) has the proper phase relationship to the sideband signal. For upper sideband signal reception, the CW Pitch knob must be set on the plus (+) side for intelligible reception. For lower sideband reception, the CW Pitch knob must be set on the minus (-) side for intelligible reception

The RF (sensitivity) control should be advanced the least amount required for the desired audio output. The use of a minimum sensitivity control setting insures that no overload distortion occurs in the receiver for single sideband reception.

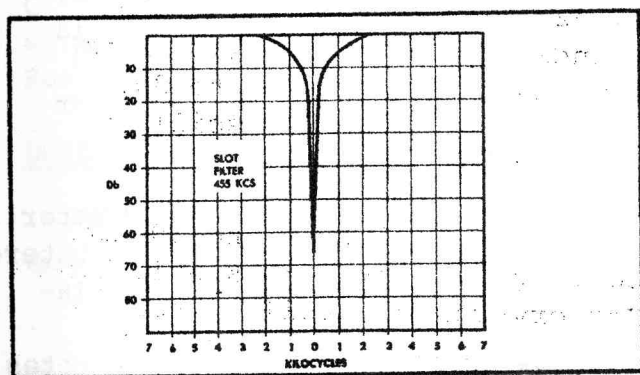

Fig. 6

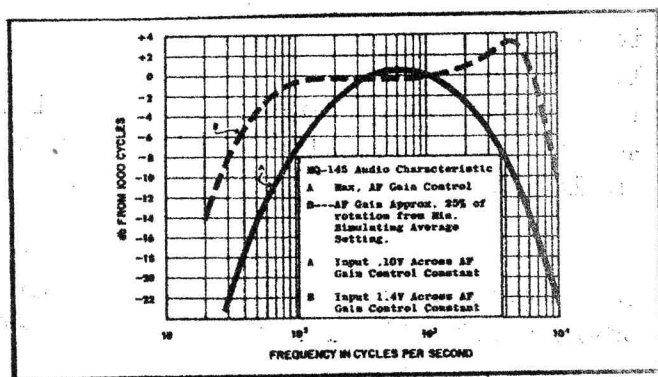

Fig. 7

CIRCUIT THEORY

The HQ-145A superheterodyne communications receiver employs double conversion on all signals above 10 megacycles. This receiver provides continuous coverage of all signals between the range of 540 kilocycles and 30 megacycles. Eleven tubes are used including the voltage regulator, and 100 Kcs Crystal Calibrator (optional accessory). The circuitry of the receiver includes an adjustable IF bandwidth selector (crystal filter), a crystal phasing control, a slot frequency and depth control, a series noise limiter and special band spread ranges for the 80, 40, 20, 15 and 10 meter amateur radio bands.

PRE-SELECTION

The antenna input coupling and RF amplifier stage provide the necessary pre-selection and gain for high performance and rejection of undesired signals. The high signal level at the 1st mixer grid, V2, contributes to a favorable signal-to-noise ratio.

Both grid and plate circuits of the RF stage are tuned (except plate circuit on .54 - 1.6 Mcs Band); individual tuning coils are selected for each band.

The antenna compensation capacitor, adjustable from the front panel, permits the receiver to be resonated for optimum performance with the particular antenna in use.

CONVERTER STAGE

A high degree of oscillator stability is attained by the use of a separate mixer (6BE6) V2, and an independent oscillator (6C4) V9.

The output signal from the RF amplifier V1 is heterodyned with the output of the local high frequency oscillator V9 and electronically combined within the mixer tube V2. On the .54 to 1.6 Mcs, 1.6 to 4.0 Mcs, and 4.0 to 10.0 Mcs bands the local oscillator is located 455 Kcs above the signal frequency. On the 10.0 to 30.0 Mcs and the 20 meter bandspread positions the local HF oscillator is located at 3035 Kcs above the signal frequency.

When operating on 10.0 to 30.0 Mcs and the 20, 15 and 10 meter band spread positions, the difference frequency of 3035 Kcs is heterodyned with the output of the 2580 Kcs crystal controlled oscillator and electronically combined in the converter tube V3 (6BE6), to produce 455 Kcs, 2nd IF. When the Band Selector switch indicates

.54 - 1.6 Mcs, 1.6 - 4.0 Mcs, or 4.0 - 10.0 Mcs, the crystal oscillator section of the converter tube ceases to oscillate, and the converter becomes a regular 455 Kcs IF amplifier.

Low-loss tube sockets, low-loss phenolic insulation, temperature compensating capacitors, and stable coaxial trimmers all contribute to the excellent oscillator's stability. Additional frequency stability is attained by applying a regulated voltage to the oscillator circuit, and by the rugged constructional design of the entire HF oscillator section.

455 KCS IF AMPLIFIER

The output of the second conversion stage V3 is fed into two stages of 455 Kcs IF amplification. The interstage coupling network to the first tube contains the well known Hammarlund 455 Kcs Crystal Filter and phasing network.

The Crystal Selectivity switch provides six different bandwidths which enable the operator to successfully receive signals under the most severe conditions of interference due to atmospheric or man made noises. The six position Selectivity switch includes an Off position (highest fidelity) and five progressively increasing selective bandwidths as shown in Figure 5.

Switch positions Off, 1, 2 and 3 are recommended for phone or single sideband reception. Positions 4, and 5 are recommended for reliable CW or code reception. The phasing capacitor C16 may be adjusted to provide additional rejection to very strong, closely spaced, interfering signals.

The output circuit of the first 455 Kcs IF amplifier consists of two IF transformers T9 and T10 which are interconnected by means of a network of resistors, capacitors, and coils comprising the Slot Filter section. This low-impedance network forms a balanced bridge arrangement known as a Bifilar "T" trap. The slot filter inductor L3 and slot tuning capacitor C22 (with capacitors C20, and C21) form a tuned circuit which presents a very high impedance to signals passing through at the resonant frequency (See Figure 7). Resistive balance is controlled by the Slot Depth potentiometer R21.

DETECTOR AND NOISE LIMITER

One section of 6AL5 tube, V6, is used for the second detector and AVC system. This system produces a minimum of distortion.

The other half of V6 operates as a series, self-adjusting noise limiter. It will reduce automobile ignition and other types of impulse noise to minimum. Intelligibility is not affected by

the noise limiter, although it may be switched off if desired.

AVC SYSTEM

Automatic Volume Control minimizes fading and signal strength variations by controlling the gain of the RF stage V1 and IF stage V4. As a result, a comfortable and constant level of audio is maintained.

AUDIO AMPLIFIER

The first audio stage is a resistance coupled voltage amplifier employing one section of the 12AX7 (V7A). The audio output stage is a 6AQ5 beam power amplifier (V8) providing an undistorted output level of at least one watt.

A feature of the audio system is the variable negative feedback employed (See Auto-Response Curve, Figure 8). Maximum feedback is provided at low settings of the AUDIO GAIN control for the fine quality reception of local broadcast and strong short wave stations. As the AUDIO GAIN control is increased, the feedback decreases, so that on reception of weak signals additional selectivity is provided by the audio section. This results in an increased signal-to-noise ratio. A further advantage is the critical damping of the speaker for elimination of speaker "hangover". This upgrades the reception of speech and music and decreases the noise output of the receiver. Another advantage is the reduction of distortion at lower settings of the AUDIO GAIN control.

"S" METER (CARRIER LEVEL)

The "S", or Tuning, Meter is provided to assist in tuning and to give an indication of relative signal strength. Because the meter readings are proportional to AVC voltage, it is operative only in the Receive Position with AVC "ON".

The meter, which is calibrated to 40 db over S-9, is factory adjusted so that a signal input of approximately 50 microvolts gives a reading of S-9. Each "S" unit indicates a 6 db increase, equivalent to doubling signal strength. Should meter readjustment be necessary:

1. With receiver off, mechanically adjust meter pointer to zero with the aid of a small screw-driver.
2. Turn power on, set function switch to REC., and Sensitivity control to MAX.

3. Allow the receiver to warm up for at least 15 minutes.
4. With AVC ON, and the Antenna Terminals shorted, turn Zero Adjust potentiometer R24 until meter pointer indicates "0".

BEAT FREQUENCY OSCILLATOR

The Beat Frequency Oscillator control L8 varies the tuning of the 455 Kcs BFO (1/2 of 12AX7-V7B) over a range from zero beat to plus or minus 2 Kcs. The BFO is connected in an ultra stable modified Colpitts oscillator circuit. The high C to L ratio tuned circuit with the addition of the temperature compensating capacitor C56 substantially contribute to the outstanding performance of this section of the receiver.

CRYSTAL CALIBRATOR (OPTIONAL ACCESSORY)

A 6BZ6 vacuum tube, a hermetically sealed quality quartz crystal unit, and associated components form a highly stable 100 Kcs crystal-controlled oscillator to provide calibrating markers at 100 Kcs intervals throughout the range of the receiver. A ceramic trimmer capacitor located on the calibrator assembly is provided for accurately adjusting the oscillator frequency to zero beat with any primary frequency standard signal off the air such as "WWV".

SERVICE AND ALIGNMENT PROCEDURE

NOTE

Before servicing this receiver, disconnect the unit from the power source and remove all lead wires attached to the terminal connections located at the rear of the chassis apron. Carefully turn the receiver on its front panel and rest the unit on top of smooth clean surface (preferably a soft cloth). Remove the three No. 10 Hexagon head machine screws which fasten the chassis to the cabinet at the rear skirt. Remove the knob from the clock adjustment shaft if the receiver is equipped with a clock assembly. Lift the cabinet straight up and off the chassis. To re-assemble, reverse this procedure.

RF AND IF ALIGNMENT

Two non-metallic alignment tools are required for the complete alignment:

General Cement Co. No. 5097 or equal

General Cement Co. No. 8282 or equal

Unless otherwise specified, the front panel controls shall be positioned as follows for the complete alignment of the receiver:

Send-Receive-CW/ SSB-Cal Switch	Receive
Selectivity Switch	Off
Crystal Phasing	Triangular Marker (Mid-position)
Slot Frequency	Clockwise
Slot Depth	Clockwise
Main Tuning Control	4.0 Mcs
Band Spread Control	Extreme Clockwise Marking
Tuning Range Switch	1.8 - 4.0 Mcs
Antenna Trimmer	Mid-position
AVC-ON-OFF Switch	OFF

Noise Limiter Switch	OFF
RF (Sensitivity) Control	Adjust to prevent overloading
AF (Gain) Control	Minimum Gain
Timer Switch	On
Beat Frequency Oscillator Control	Triangular Marker (Mid-position)

NOTE

The receiver should be warmed up for a period of at least 1/2 hour before proceeding with the complete alignment.

IF ALIGNMENT

A high degree of stability has been designed into the receiver making re-alignment unnecessary unless electrical parts are replaced which would affect the tuning of the IF circuits; such as IF transformers, or 455 Kcs crystal.

If for any reason, the 455 Kcs IF system performs unsatisfactorily, it is strongly recommended that a standard tone modulated AM signal generator be used for thoroughly checking the performance of this receiver before proceeding with the alignment.

The IF alignment of the receiver can be accomplished by the sweep generator method and the AM single frequency method. The sweep generator method is the preferred method for re-alignment of the HQ-145A Communications Receiver because of the greater precision to which the IF coils can be adjusted. However, in view of the fact that there are a very limited number of 455 Kcs Sweep Generators available as test equipment, the alternate single frequency alignment method is also described.

SWEEP GENERATOR METHOD (PREFERRED)

The IF alignment of the receiver requires the use of a 455 Kcs sweep generator, an oscilloscope, and a phasing network for proper synchronization. Alignment should not be attempted unless suitable equipment is on hand and considerable experience in sweep alignment techniques has been acquired.

In practically all of the cases requiring re-alignment an over-all touch-up operation will be required. This is accomplished by connecting the sweep generator cable to the grid of the first mixer (pin 7-V2), and connecting the oscilloscope input cable across the volume control. Connect a large ceramic disc type of capacitor (.01 mfd) in series with the cable inner conductor (dc blocking capacitor).

Apply a small amount of sweep signal to the receiver and adjust the oscilloscope for a relatively large amount of gain and satisfactory picture size. Check the phasing control knob position to indicate the triangular indice and turn crystal knob to position "4". Adjust phasing network so that forward and return traces of the sweep co-incide.

Peak align 455 Kcs windings for maximum amplitude (T5 and T6 (top cores), T7, T9, T10, T11) and omit T8. Then turn crystal selectivity knob to position "1", and adjust T8 so that a tall selectivity curve with a slightly flattened peak is obtained. At the proper adjustment the abrupt change (spike) in the smooth selectivity curve will be located very close to the baseline of the trace, and the amplitude of the trace on positions "OFF" and "1" will be practically identical.

Re-adjust all 455 Kcs IF coils again (except T8) so that symmetry and phasing coincide on positions "OFF", 1, 2, 3, and 4.

NOTE

The sweep generator frequency must be adjusted to obtain exact coincidence of the forward and return trace. If complete coincidence is not obtained, alternately make slight adjustments of the phasing control and sweep generator frequency until the images coincide. After these steps have determined the exact frequency of the 455 Kcs crystal, the center frequency of the sweep generator should be re-adjusted.

SINGLE FREQUENCY METHOD (ALTERNATE)

Connect the output cable of the 455 Kcs unmodulated signal generator to the grid (pin 7) of the first mixer V2 and the chassis. Connect a dc vacuum tube voltmeter between the diode plate pin 1 (V6) 6AL5 socket and chassis.

Adjust the Front Panel Controls as specified above, and adjust the Signal Generator frequency for maximum output with crystal selectivity set to position "4". Turn to position No. "1" and peak align all 455 Kcs IF transformer windings (T5 and T6 top cores), T7, T8, T9, T10 and T11). Repeat procedure on crystal

positions 1 and 4 to insure accurate coil adjustments.

BEAT FREQUENCY OSCILLATOR ALIGNMENT

With the same equipment and set-up as used in the preceding paragraph, turn crystal selectivity to position 5 and adjust the signal generator frequency for maximum reading. Turn signal generator modulation on, turn crystal selectivity off, and turn Send-Receive switch to CW/SSB.

Loosen stop collar set screws on CW Pitch shaft (located directly behind the Front Panel). Turn CW Pitch knob for an audible zero beat on the loudspeaker. Tighten set screws so that the longer set screw is located in the mid-position with respect to the stop lug. Loosen the CW Pitch knob set screws and adjust knob indication so that it points vertically up on zero beat (mid-position).

3035 KCS IF ALIGNMENT

After 455 Kcs IF Alignment using either system, peak align the bottom cores of T5 and T6 by feeding in a 3035 Kcs signal in the same manner described in previous paragraph, and make certain that the Band Selector switch indicates 10-30 Mcs Range.

RF ALIGNMENT

1. The slugs and trimmers have been factory adjusted and should require a minimum amount of adjustment during re-alignment.
2. All Antenna, RF, and Oscillator coil adjustments are made from the top side of the chassis at the specified frequencies as shown in figure 9.
All trimmer adjustments are made at the specified frequencies as shown in figure 10.
3. Connect the unmodulated, signal generator output cable to the antenna and ground terminals of the receiver, with the Terminal A adjacent to the G terminal jumped together (see figure 4). Insert in series with the inner conductor of the output cable, a 100 ohm dummy antenna resistor.
4. Set the controls the same as for IF alignment as described above.
Adjust the Sensitivity Control as required to prevent overloading and also to obtain sufficient signal reading on the VTVM connected to pin 1 of V6 (6AL5).

5. The Oscillator Circuit is first adjusted to indicate proper dial calibration at the specified frequencies on each band, then the RF and finally the Antenna Circuits. A certain amount of interaction will occur between the Oscillator and RF adjustments, particularly on the higher frequency bands. Final adjustment should be accomplished by combined or alternate adjustment of the oscillator and RF for maximum amplitude and accurate dial calibration.

NOTE

The trimmer adjustments should always be the final adjustment for each band

There is no adjustment of the RF Amplifier on the .54 to 1.6 Mcs band.

6. Note that the HF oscillator frequency in the HQ-145 is always located above the signal frequency by 455 Kcs for signals located below 10 Mcs., and by 3035 Kcs. for signals located above 10 Mcs. It is necessary to make certain the oscillator frequency is always adjusted so that it is above the incoming signal frequency.

7. During RF alignment the Antenna Tuning Capacitor C3 must be placed in the mid-position of its range on all bands except the broadcast band.

On the broadcast band (.54 to 1.60 Mcs), the antenna tuning capacitor (C3) is adjusted to approximately 20 degrees from its maximum capacity position when the Main Dial indicates 600 Kcs. With this setting the Antenna Coil (T1) is peak aligned.

When the Main Dial indicates 1600 Kcs the Antenna tuning capacitor (C3) will tune for maximum signal at approximately 20° from its minimum capacity. While tuning across the band, the capacitor setting required for maximum signal pick-up will progressively change from maximum to minimum as the frequency of received signal increases.

POSSIBLE RECEIVER DIFFICULTY

1. If upon turning the power "ON" the dial scales are not illuminated, and after two minutes of waiting the receiver still fails to operate, the clock timer switch is not making contact. Manipulate the Clock Timer Knob to indicate the "ON" position with the AC power switch, (Audio Gain Knob) "ON". The Clock Timer Switch should always point to the "ON" position unless the Automatic Timer is utilized.
2. Excessive hum usually is due to a defective 12AX7 tube (V7). This tube type may test good in a tube testing device but may be unusable because of higher than average heater-to-cathode leakage within the tube.
3. Poor Noise Limiter action is usually due to a poor or defective 6AL5 tube (V6)). Remember that the use of the noise limiter will always result in some signal distortion for effective noise limiting action. When listening to strong broadcast stations or strong local signals, the noise limiter switch should be in the "OFF" position unless slight distortion is preferable to excessive pulse type of noise such as ignition interference.
4. Erratic or Poor "S" Meter performance is due to the two 6BA6 (V4 and V5) vacuum tubes. Merely interchanging these tubes may provide sufficient improvement. Replacing one or both of these tubes may be advisable before suspecting other troubles.

The majority of all receiver troubles have been found to be due to one or more defective tubes. Rough handling in shipment is largely responsible for the poor performance of the receiver.

Please, therefore, be sure to follow the above suggestions and have all vacuum tubes tested before writing to the Hammarlund Mfg. Co.

MAINTENANCE

The HQ-145A is designed to give years of trouble-free service. Tube failure is the most common source of trouble. The second most common cause of difficulty is component failure among small resistors and fixed capacitors.

The following charts give voltages and resistances between tube socket terminals and chassis. Voltages indicated are those measured with a vacuum tube voltmeter; resistances with a vacuum tube ohmmeter. Slight variations in the order of 10 percent from indicated values should be disregarded.

With the aid of the chart and schematic diagram, components can usually be located. The parts listing in the back pages of this manual gives component values and Hammarlund part numbers.

Standard items may be purchased locally, non-standard components are available on order from the factory.

A sensitive communications receiver should be entrusted only to a qualified technician. Should difficulty be experienced, please write Hammarlund Manufacturing Company, for advice or to arrange for factory service.

TABLE 1. TUBE SOCKET VOLTAGES

Controls adjusted to the following positions unless otherwise specified:

- 10-30 Mcs
ON-OFF Switch - OFF
Volume Limiter - OFF

Function Switch - Receive
RF Gain - Max.
AF Gain - Max.

Antenna - Disconnected
Crystal Selectivity - OFF
AC line Volts - 117 V. AC

SOCKET	SOCKET PIN NUMBER								
	1	2	3	4	5	6	7	8	9
RF Tube 6BZ6	0	1.55	0	6.3AC	245	105	0	--	--
1st Mixer 6BE6	-1.6 to -7.5	1.2	0	6.3AC	243	80	0	--	--
2nd Mixer 6BE6	-3.1	0	0	6.3AC	238	77	-.66	--	--
IF Ampl. 6BA6	0	0	0	6.3AC	225	98	2.35	--	--
IF Ampl. 6BA6	0	0	0	6.3AC	230	100	2.65	--	--
DET. -NL 6AL5	-2.0	-3.2	0	6.3AC	0	0	-2.0	--	--
Audio-BFO 12AX7	90	0	.75	6.3AC	6.3AC	168	-2.3	0	0
PWR. Ampl. 6AQ5	0	15	0	6.3AC	255	245	0	--	--
HF Osc. 6C4	100	--	6.3AC	0	--	-2.5 to -3.7	0	--	--
Volt. Reg. OB2	105	--	--	--	105	--	0	--	--

TABLE 2. TUBE SOCKET RESISTANCES
 CONDITIONS SAME AS IN THE TABLE 1. - TUBE SOCKET VOLTAGES.

PIN SOCKET	SOCKET PIN NUMBER							
	1	2	3	4	5	6	7	8
RF Tube 6BZ6	10K	180	0	--	100K	100K	0	--
1st Mixer 6BE6	47K	470	0	--	100K	100K	0	--
2nd Mixer 6BE6	22K	0	0	--	100K	100K	100K	--
IF Ampl. 6BA6	0	0	0	--	100K	100K	180	--
IF Ampl. 6BA6	0	0	0	--	100K	100K	300	--
DET. -NL 6AL5	1.2K	9.0	0	--	0	0	1.2M	--
Audio-BFO 12AX7	600K	1.0M	2200	--	--	INF	47K	0
PWR. Ampl. 6AQ5	500K	430	0	--	100K	100K	500K	--
HF Osc. 6C4	100K	--	--	0	--	47K	0	--
Volt. Reg. 0B2	100K	--	--	--	100K	--	0	--

PARTS LIST HQ-145A

Schematic Designation	Description	Hammarlund Part No.
<u>Capacitors</u>		
C1, A-C	Variable, Main tuning	T41604-6
C2, A-F	Variable, Bandsread	T41604-7
C3	Variable, Antenna Compensator	K34454-G24
C4,C5,C6,C7,C8, C14,C15,C18,C19, C27,C28,C29,C31, C32,C33,C39,C55, C67,C68,C69	Fixed, ceramic disc, .01 mf, 600 W.V.D.C.	M23034-19
C10	Fixed, silver mica, 2.0 mmf 500 W.V.D.C.	K23006-37
C12	Fixed, silver mica, 560 mmf 500 W.V.D.C.	K23027-6
C13	Fixed, silver mica, 10 mmf, 500 W.V.D.C.	1519-01-00006
C16	Variable, crystal phasing	M11776-G2
C17, C34,C52,C53	Fixed, silver mica, 100 mmf 500 W.V.D.C.	K23006-1
C20	Fixed, silver mica, 1200 mmf 500 W.V.D.C.	K23027-4
C21	Fixed, molded mylar, 3300 mmf 200 W.V.D.C.	K23044-1
C22	Variable, Slot Frequency	K420
C23,C24	Fixed, ceramic disc, .01 mf 1000 W.V.D.C.	M23034-25
C25,C26,C66	Fixed, ceramic disc, .04 mf 600 W.V.D.C.	M23034-12
C30	Fixed, ceramic disc, .005 mf 1000 W.V.D.C.	M23034-10
C35,C36,C47,C49 C50,C51	Variable, rotary trimmer	K23008-1
C38	Fixed, disc NPO 6.8 PF 1000 W.V.D.C.	1509-01-00022
C41	Fixed, Temp. Comp., 2.7 mmf 1000 W.V.D.C.	K23010-1
C42	Fixed, Temp. Comp., 6.8 mmf, 1000 W.V.D.C.	K23010-11
C43	Fixed, silver mica, 1170 mmf 500 W.V.D.C.	K23027-15
C44	Fixed, silver mica, 3000 mmf 300 W.V.D.C.	K23041-8
C45	Fixed, silver mica, 1300 mmf 300 W.V.D.C.	K23041-7
C46	Fixed, silver mica, 430 mmf 300 W.V.D.C.	K23006-44

PARTS LIST HQ-145A (CONT'D)

Schematic Designation	Description	Hammarlund Part No.
<u>Capacitors</u>		
C48	Fixed, Temp. Comp., 2.7 mmf 500 W.V.D.C.	K23061-30
C54	Fixed, Temp. Comp., 1.5 mmf 500 W.V.D.C.	K23061-20
C56	Fixed, Temp. Comp., 130 mmf 500 W.V.D.C.	K23063-92
C57	Fixed, silver mica, 1200 mmfd 500 W.V.D.C.	K23027-13
C58,C59	Fixed, silver mica, 4300 mmf 500 W.V.D.C.	K43042-2
C60	Fixed, silver mica, 3 PF 500 W.V.D.C.	1519-01-00011
C61	Fixed, silver mica, 510 mmf 500 W.V.D.C.	K23027-3
C62,A,B,C,	Fixed, electrolytic, 40/60/25 mfd 450/450/50 W.V.D.C.	K15504-64
C63,C64	Fixed, ceramic disc, .01 mf 1400 W.V.D.C.	M23034-26
C65	Fixed, silver mica, 8.0 mmf 300 W.V.D.C.	K23006-31
C70	Fixed, mylar .22 mf, 400 W.V.D.C.	K1528-02-020011
<u>Resistors</u>		
R1,R3	22 ohms, 1/2 w. 10%	K19309-9
R2	180 ohms, 1/2 w. 10%	K19309-31
R4	470 ohms, 1/2 w. 10%	K4703-01-00328
R5,R38,R39	47K ohms, 1/2 w., 10%	K19309-89
R6	6.2K ohms, 1/2 w., 5%	K19309-17
R7,R10,R11,R19, R25,R26,R29,R34, R44	2.2K ohms, 1/2 w., 10%	K19309-57
R8	3.3K ohms, 1/2 w., 10%	4703-01-00350
R9	4.3K ohms, 1/2 w., 5%	K19309-21
R12	300 ohms, 1/2 w., 5%	K19309-20
R13,R31	100 ohms, 1/2 w., 10%	K19309-25
R14	33 ohms, 1/2 w., 10%	K19309-13
R15	470K ohms, 1/2 w., 10%	K19309-11
R16	180 ohms, 1/2 w., 5%	K19309-26
R17	1200 ohms, 1/2 w., 5%	K19309-26
R18	Variable, 10K ohms, Sensitivity	K26218-5
R20	120 ohms, 1/2 w., 5%	K19309-25
R21	Variable 200 ohms slot depth	K15368-7
R22	68 ohms, 1/2 w., 5%	K19309-25
R23	39 ohms, 1/2 w., 5%	K19309-25
R24	Variable, 300 ohms, Meter Zero Adj.	K15379-1
R27	Variable, 1.0 megohm, Audio with Power Switch	K38977-1

PARTS LIST HQ-145A (CONT'D)

Hammarlund

Part No.

Schematic
Designation

Description

Resistors

R28	47 ohms, 1/2 w., 10%	K19309-17
R30	430 ohms, 1 w., 5%	K19310-212
R32	10K ohms, 1/2 w., 10%	K19309-73
R33,R37	1K ohms, 1/2 w., 10%	K19309-49
R35	10 ohms, 1/2 w., 10%	K19309-1
R40	100K ohms, 1 w., 10%	K19309-97
R41	4K ohms, 10 w., 10%	K19337-3
R42	100K ohms, 1/2 w., 10%	K19309-97
R43	6.8 megohms, 1/2 w., 10%	K19309-141
R45	68K $\pm 10\%$, 1/2 w.	K4703-01-00354
R46	22 ohms, $\pm 10\%$ 1 w.	K4704-01-00612
R47	1 meg, $\pm 10\%$ 1/2 w.	K4703-01-00368
R48	2.2 meg, $\pm 10\%$ 1/2 w.	K4703-01-00372

Coils

L1	RF Choke, 38 microhenries	K15629-1
L2	Bifilar coil	K42032-1
L3	Slot Filter coil	K42034-1
L4	RF Coil Assembly, .54 to 1.6 Mcs, 1.6 to 4.0 Mcs	K38816-1
L5	RF Coil Assembly, 4.0 to 10.0 Mcs, 10.0 to 30.0 Mcs	K38817-;
L6	Osc Coil Assembly, .54 to 1.6 Mcs, 1.6 to 4.0 Mcs	K38818-1
L7	Osc Coil Assembly, 4.0 to 10.0 Mcs, 10.0 to 30.0 Mcs	K38819-1
L8	BFO Coil Assembly	K38989-G1
L9	Filter Choke	K38939-1

Transformers

T1	Antenna Coil Assembly, .54 to 1.6 Mcs	K38812-1
T2	Antenna Coil Assembly, 1.6 to 4.0 Mcs	K38813-1
T3	Antenna Coil Assembly, 4.0 to 10.0 Mcs	K38814-1
T4	Antenna Coil Assembly, 10.0 to 30.0 Mcs	K38815-1
T5,T6	IF transformer, composite	K26402-1
T7,T8	IF transformer, crystal filter	K26399-1
T9,T10	IF transformer	K38946-1
T11	IF transformer	K38829-1
T12	Audio output transformer	K38828-2
T13	Power Transformer 230/115 volt primary	P5603-02-00011

Switches

S1, A,B,C	Switch, wafer, Ant, RF, Osc	K38824-1
S1 D	Switch, wafer, Osc. 2nd Mixer	K26377-1
S2	Switch, Selectivity	K26396-1

PARTS LIST HQ-145A (CONT'D)

Schematic Designation	Description	Hammarlund Part No.
<u>Switches</u>		
S3,S4	Switch, SPST (AVC ON-OFF or Noise Limiter)	K38857-1
S5	Switch, Send-Receive-CW/SSB-Cal.	K26395-1
S6	Switch, Power ON-OFF (part of R27)	
<u>Special Assemblies</u>		
CMC	Crystal panel, clock window	K38877-1
M1	Clock, Telechron auto-timer	K38874-1
Y1	Meter, "S" (Carrier Level)	K26149-4
Y2	Quartz crystal, 2,580 Mcs	K38972-2
Z1	Quartz crystal, 455 Kcs	K26404-1
Z2	RC printed network (AVC-Noise)	K38885-1
	RC printed network (Ammeter)	K38846-1
<u>Crystal Calibrator (Accessory)</u>		
C301	Capacitor Fixed, silver mica, 100 mmf 500 W.V.D.C.	K23006-1
C302	Capacitor, Variable, Frequency Adjust	K23038-2
Y301	Quartz crystal, 100 Kcs	K38661-1
Z301	RC printed network (Calibrator)	K38981-1
	Crystal Socket	K16092-5
	Power Plug	K26412-1
	Power Plug Cover	K26419-1
<u>Miscellaneous</u>		
DS1, DS2	Lamp pilot, No. 47 6.3 V., .15 A.	K16004-1
J1	Phone Jack	K35608-1
J2	System Socket	K16083-1
J3	Accessory Socket	K41138-1
	Spring	K38895-1
J4	Socket 115/230 V.	K2126-01-00002
J5	Calibrator Socket	K2102-02-00014
<u>OPTIONAL ACCESSORIES</u>		
	Plug-in crystal calibrator assembly XC-100P	PL38653-G7
	Telechron Clock Assembly Conversion Kit including instructions for converting model HQ-145A to model HQ-145AC	PL26380-G1
	Loudspeaker Assembly in cabinet matched to the models HQ-145A, HQ-145AC and HQ-145AXC	PL26394-G1

PARTS LIST HQ-145A (CONT'D)

Schematic Designation	Description	Hammarlund Part No.
	<u>Crystal Box</u>	
CR2,CR3	Rectifier, Silicon Cer 72C	M4807-01-00001

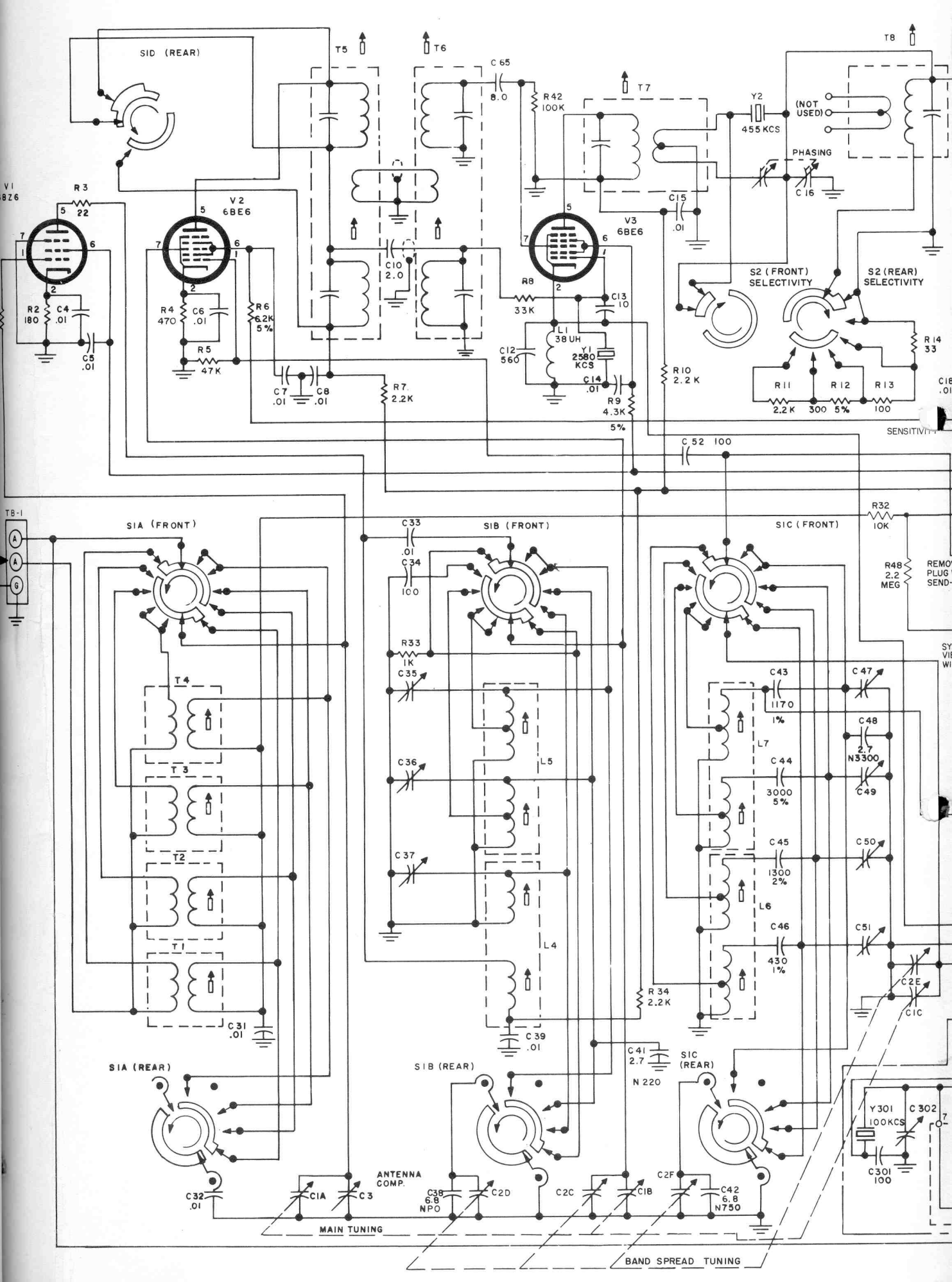

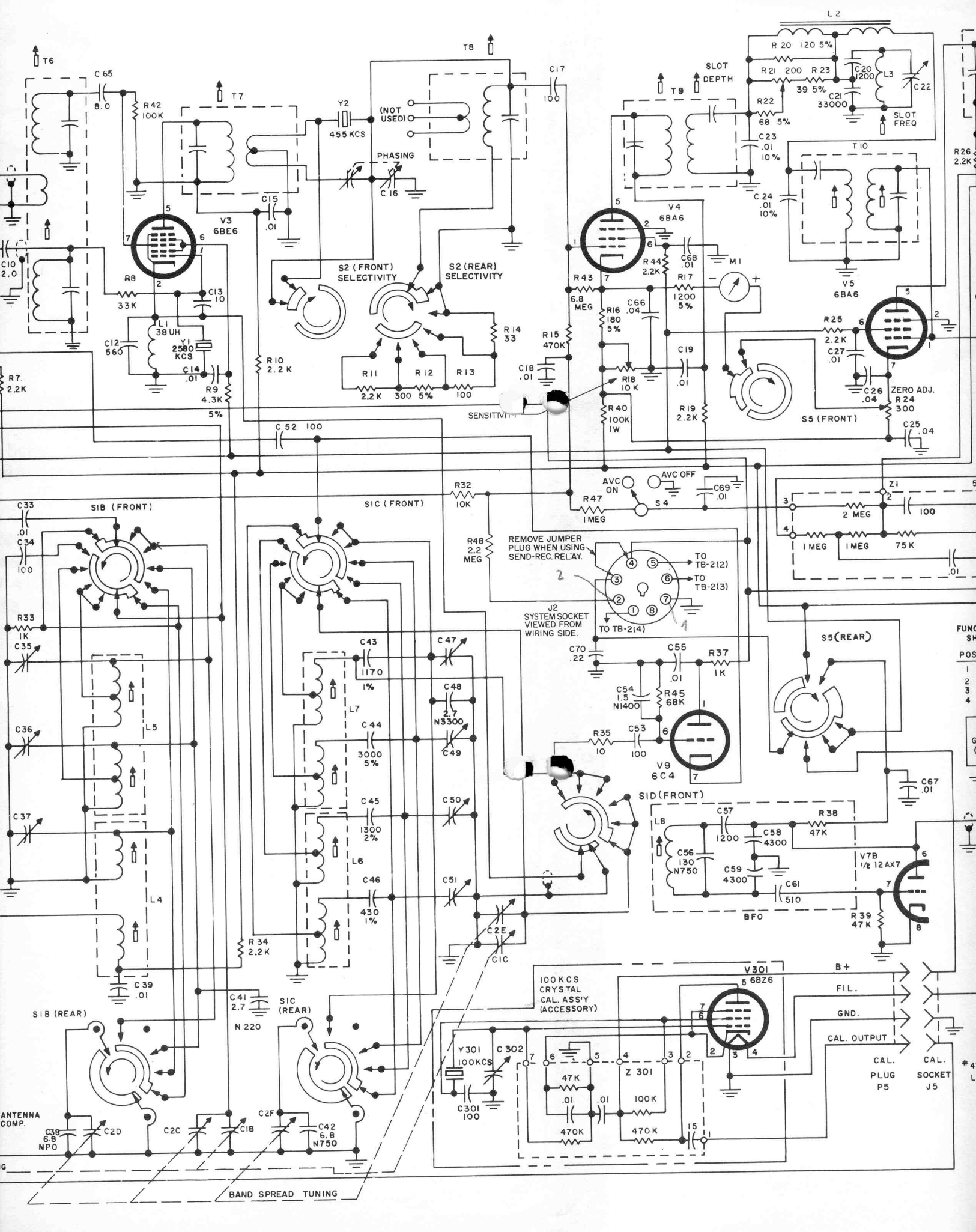

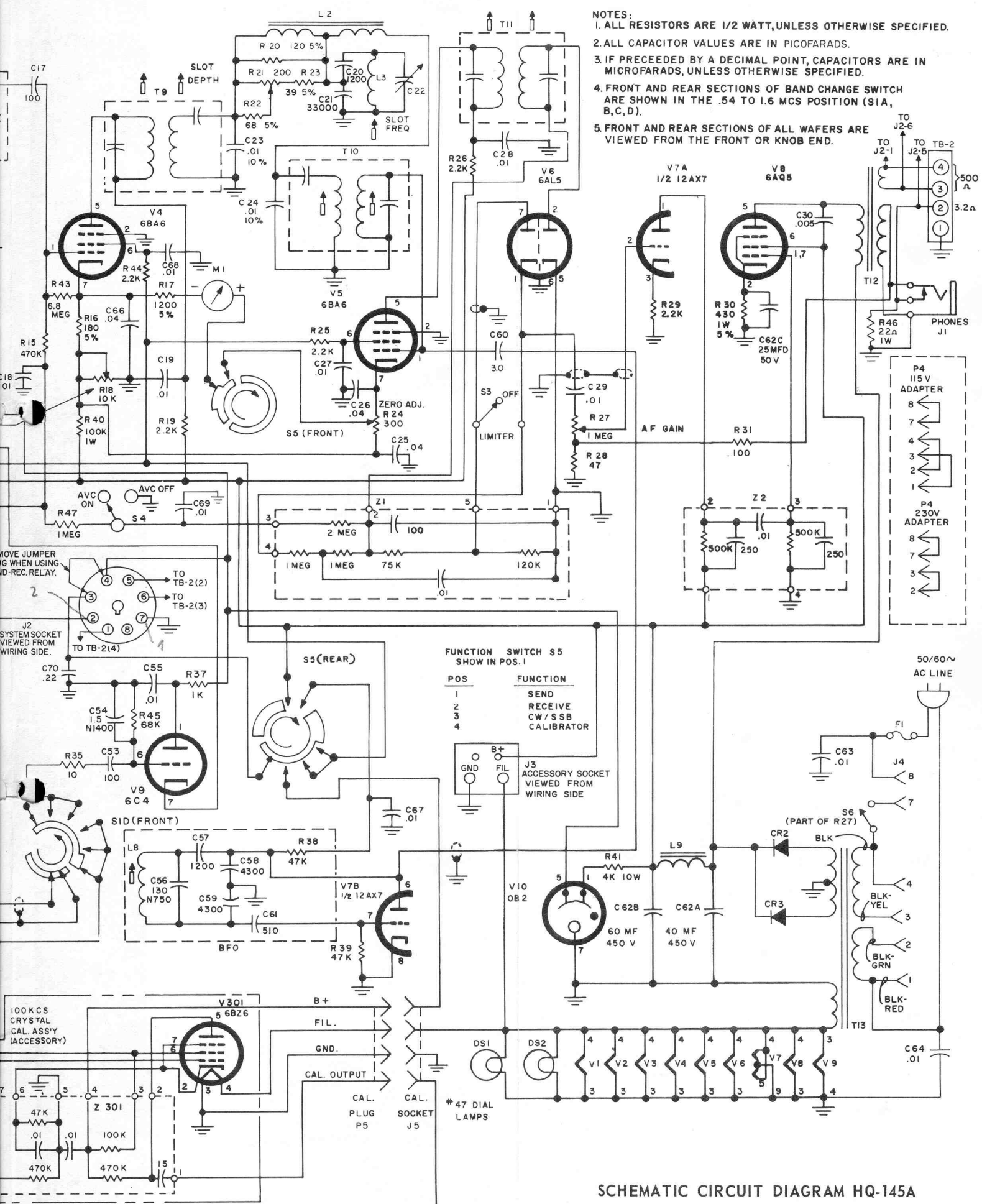

- NOTES:
1. ALL RESISTORS ARE 1/2 WATT, UNLESS OTHERWISE SPECIFIED.
 2. ALL CAPACITOR VALUES ARE IN PICOFARADS.
 3. IF PRECEDED BY A DECIMAL POINT, CAPACITORS ARE IN MICROFARADS, UNLESS OTHERWISE SPECIFIED.
 4. FRONT AND REAR SECTIONS OF BAND CHANGE SWITCH ARE SHOWN IN THE .54 TO 1.6 MCS POSITION (S1A, B, C, D).
 5. FRONT AND REAR SECTIONS OF ALL WAFERS ARE VIEWED FROM THE FRONT OR KNOB END.

FUNCTION SWITCH S5 SHOW IN POS. 1

POS	FUNCTION
1	SEND
2	RECEIVE
3	CW / SSB
4	CALIBRATOR

J3 ACCESSORY SOCKET VIEWED FROM WIRING SIDE

SCHMATIC CIRCUIT DIAGRAM HQ-145A
NO. 9001-04-00001