

## INSTALLATION

**Connection to Power Supply**—Connect Receiver to Power Supply as follows:

(1) Remove the sheet-metal covers from terminal strip (E4, Fig. 3) on rear of Receiver and from terminal strip (E1, Fig. 3) on Power Supply. See that all ten screws on each strip are unscrewed at least three turns. Then attach one end of the connector cable to each terminal strip *exactly* as shown in Fig. 3 and tighten all screws securely. Make certain that each slotted spade lug on the cable strips makes contact with its respective screw terminal *only*, since a lug jammed between *two* screws could cause considerable trouble. Immediately replace both metal covers and do not remove them while the Power Supply is connected to the a-c power line.

(2) The spacing of spade lugs on cable terminal strips is exactly the same as the spacing of screws on Receiver and Power Supply. If the two fail to go together easily, **DON'T USE FORCE**. Be sure *all* screws are unscrewed far enough. If a spade lug has been bent or pushed out of place by rough handling, straighten it and try again. Spade lugs should slip under screws from the top.

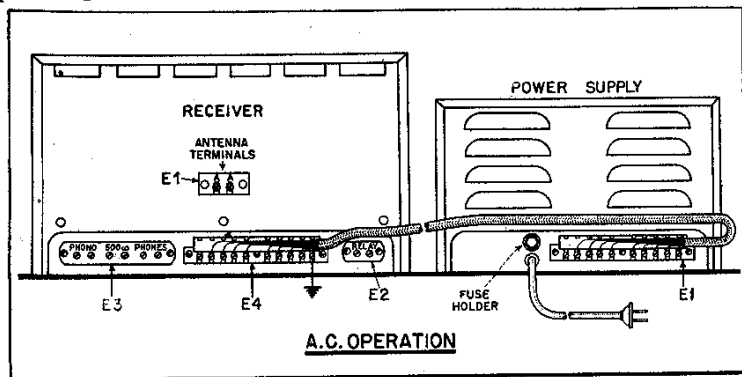

FIG. 3—Connections for power cable—A.C. operation.

**Connection for Battery Operation**—A cable for use in battery operation is available on special order. This cable (W2 in Parts List) has only one terminal strip. The other end of the cable is made up of eight loose wires. Connect this cable according to Fig. 4 (note the color code for the eight loose wires), or make up connections to serve the purpose. Connect the battery cable to the Receiver *first* and re-

place the terminal cover *before* making connections to the batteries. When discontinuing battery operation, disconnect the battery cable from the receiver. All operations of the Receiver are the same with either the Power Supply or the battery set-up.

**Chassis Ground:** It is not usually necessary to ground the Receiver chassis, but this can be done by connecting the ground lead to the left-hand PHONO or to the left-hand PHONES terminal (located on terminal strip E3, Fig. 3). These two terminals are grounded to the inside of the chassis.

**Earphones:** Plug a headset into the PHONES jack (J1, Fig. 2), or connect it to screw terminals marked PHONES on rear of chassis. No matching transformer is necessary.

**Loudspeaker:** The permanent magnet dynamic loudspeaker supplied with the Receiver has a transformer mounted on its housing. This transformer matches the voice coil of the loudspeaker to the 500-ohm output terminals (on terminal strip E3, Fig. 3) located at the rear of the chassis (marked 500 ohms). For loudspeaker operation, connect the two-wire lead attached to the terminals of the loudspeaker transformer to the 500-ohm terminals on the Receiver. Disconnecting the loudspeaker will not impair the operation of the Receiver.

**Power Transformer Primary Tap:** Before plugging the power cord into the a-c line, remove bottom plate from Power Supply to see that power cord is properly connected for the a-c voltage of the power line being used. One wire of the power cord is permanently connected to the fuse-holder (E3, Fig. 5); the other wire is connected at the factory to one of the screw terminals on terminal strip E2 (Fig. 5). These screw terminals are marked 105, 115 and 125, and are connected to primary taps on the power transformer. See that the power cord wire is connected to the screw terminal most closely agreeing with the available a-c line voltage and replace the bottom cover plate.

## POWER SOURCES

**A-C Operation . . .**

105-125 Volts, 50-60 cps

180 watts average power consumption

**Battery Operation . . .**

6-volt storage battery, drain

6.25 amperes for heaters.

Five 45-volt "B" batteries, drain

117 milliamperes at 225 volts;

4.5 milliamperes at 90 volts.

One 45-volt "C" battery, drain

10 milliamperes.

## OPERATION

a. *Radiophone Reception:* Set the front panel controls (FIG. 2) as follows:

CONTROL	POSITION
CRYSTAL SELECTIVITY	OFF
PHASING	on arrow
BAND WIDTH	3
LIMITER	Off
AVC-MANUAL	AVC
SENSITIVITY	10
BAND SPREAD	100
SIGNAL-MOD-CW	MOD
AUDIO GAIN	6
SEND-REC	REC
BEAT OSCILLATOR	0

(1) Throw OFF-ON power switch in center of panel to ON. This puts Receiver in operation.

(2) Adjust band switch (S1, FIG. 2) to a band which is likely to be very active. This will facilitate the process of getting familiar with the various adjustments. If interference is not serious, BAND WIDTH control can be adjusted to a wider band width (higher number), depending upon the degree of fidelity desired. In general, adjust this control to band width giving best tone with least interference.

(3) Do all tuning, with or without the meter with BAND WIDTH control set at 3. Other settings give wider bands, making exact tuning difficult. Make band width adjustments *after* signal is tuned properly.

(4) LIMITER-OFF-ON control turns noise limiter on and off. The noise limiter will be most valuable on the higher frequencies, where interference from automobile ignition system is most bothersome.

b. *Code Reception:* Flip AVC-MANUAL switch to MANUAL and turn down SENSITIVITY control to provide proper sensitivity.

(1) On strong signals, do not turn SENSITIVITY control all the way on, because it will cause overloading. If the AUDIO GAIN control is set at about 7, it is possible to regulate volume by using only the sensitivity control.

(2) To turn on the beat oscillator, set SIGNAL-MOD-CW switch at CW. The BEAT OSCILLATOR control varies the pitch of the beat

between oscillator and incoming signal. Use beat oscillator for code reception and for locating weak modulated signals.

(3) Fading signals can be improved by returning AVC-MANUAL switch to AVC.

c. *Crystal Filter:* First three positions of CRYSTAL SELECTIVITY control are generally used for radiophone reception and will serve for code reception where interference is not serious. Last two positions are intended for code reception *only* since they provide so narrow a band that "phone" signals are usually unintelligible. After adjusting CRYSTAL SELECTIVITY control for desired degree of selectivity, use PHASING control to eliminate or reduce any heterodyne interference or "whistle" which may be present.

d. *Receiver Silencing:* Receiver can be silenced by flipping the SEND-REC switch (S6, FIG. 2) to SEND. This operation opens the "B" supply to the R-F and 1st detector tubes (V1, V2 and V3). The Receiver then remains ready for instant service during transmission periods. Note also that instead of using the SEND-REC switch, a relay may be connected to the RELAY terminals (E2, FIG. 3) at rear of Receiver and silencing controlled by relay action, actuated, for example, by the associated transmitter. When using a relay for silencing, flip SEND-REC switch to SEND (open) and *leave* it there. While the transmitter is operating, the relay should remain *open*; when the transmitter is "off the air," the relay contacts should *close* to restore Receiver operation.

e. *Phono Operation:* Leads from a phonograph pickup may be connected to the PHONO terminals (on terminal strip E3, FIG. 3) at the rear of the Receiver. (Note that the left-hand terminal of this pair is grounded to chassis.) Use the SEND-REC switch (S6) as a "phono-radio" switch by flipping it to the SEND position, thus eliminating radio interference and making it unnecessary to hunt for a "dead spot" on the tuning dial.

f. *Tuning:* All tuning *can* be done with the MAIN TUNING control. In this case, leave the band spread dial at 100. BAND SPREAD control spreads out a narrow band of frequencies *below* the frequency to which the main dial is set. This control operates continuously throughout the entire tuning range of the Receiver, and signals can be spread out in any one of the five bands.

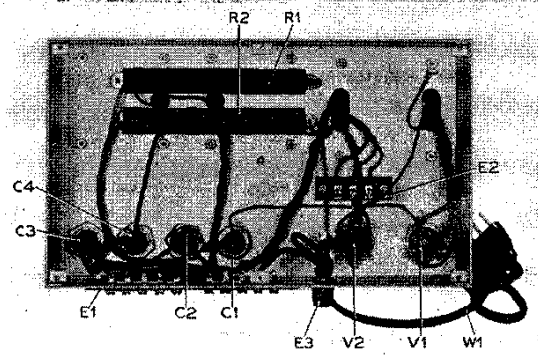

FIG. 5—Bottom view of power supply.

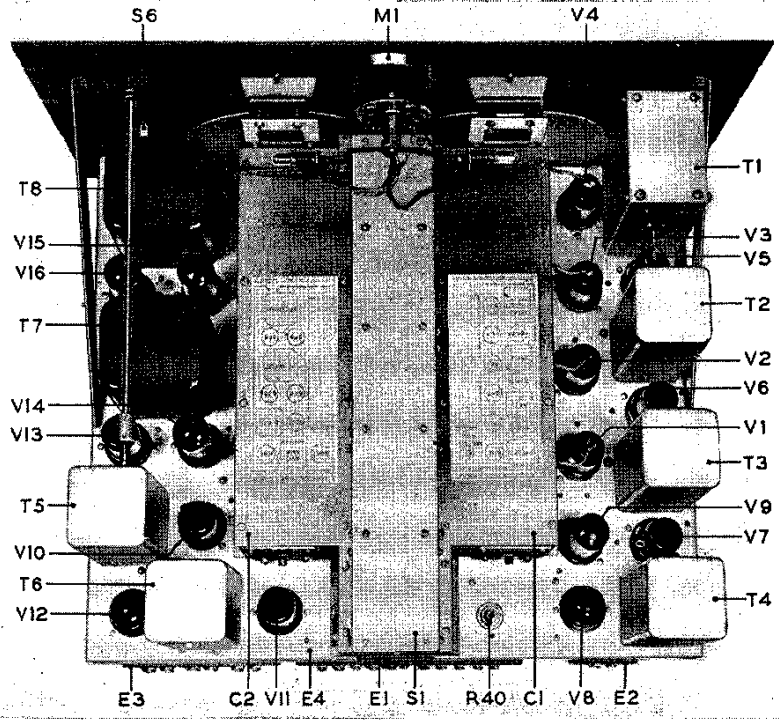

FIG. 7—Top chassis view showing arrangement of components.

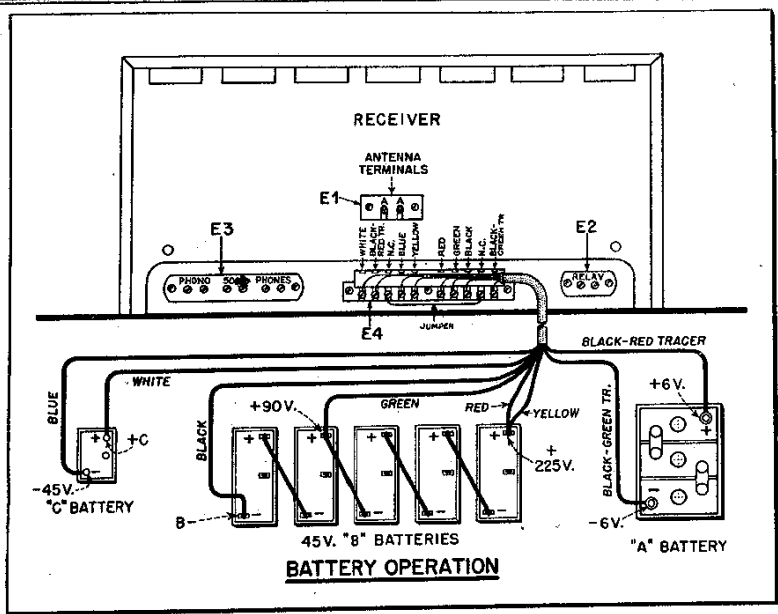

FIG. 4—Connections for power cable—battery operation.

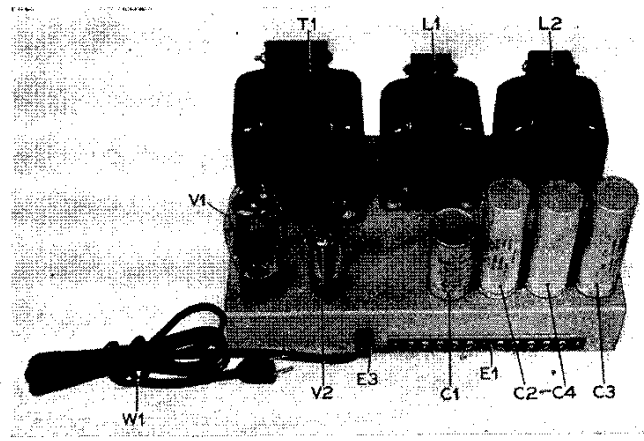

FIG. 6—Top view of power supply.

g. *Earphone Operation:* For earphone operation, plug earphones into the PHONES jack (J1, Fig. 2) provided for them on the front panel, or connect them to the PHONES terminals on the rear of the Receiver chassis. These terminals are connected in parallel with the jack on the front panel.

h. *S-Meter Tuning:* The S-meter (M1, Fig. 2), a tuning guide, operates only when the Receiver is set for AVC. Its reading increases as the Receiver approaches resonance with the incoming signal. Exact resonance is shown by the greatest reading of the meter. BAND WIDTH control must be set at 3 for accurate tuning by means of the meter. A screwdriver adjustment (R40, Fig. 7) at the rear of the chassis varies the resistance in shunt with the meter. By means of this adjustment, an "S9" reading may be obtained on any input between approximately 10 and 10,000 microvolts. The normal factory adjustment is made on an input of 50 microvolts, and when so adjusted each "S" number represents a change in signal input of approximately 6 decibels, or a ratio of two-to-one.

### CIRCUIT ARRANGEMENT

#### RF AMPLIFIER

a. *Antenna Circuit:* The antenna is coupled to the grid of the 1st RF amplifier (V1) through an input transformer having an untuned primary and tuned secondary. The terminals of the primary coils are ungrounded, and are connected through a double-pole section (S1A) of the band switch to the "A," "A" terminals (E1) on the rear of the tuning unit. This symmetrical arrangement of the antenna primary coils permits full advantage to be taken of the noise-reducing properties of a balanced transmission line lead-in. The impedance of the input circuit averages approximately 100 ohms throughout the tuning range of the Receiver.

b. *Amplifier Stages:* There are two stages of RF amplification preceding the first detector or mixer. These stages are coupled by means of RF transformers having tuned secondaries and low inductance untuned primaries. The plates of the two RF amplifier tubes (V1, V2) are shunt fed through RF chokes L35, L36 and are coupled to their respective tuned circuits through fixed capacitors C26, C30. This shunt feed keeps plate voltage off the tuned RF amplifier circuits. Two stages of RF amplification, in the frequency range covered by the

540-1240 kc band, normally provide more selectivity than is desirable for the reception of high-fidelity programs. To prevent loss of audio quality resulting from RF side-band cutting, resistors (R4, R8) have been placed in series with the secondaries of RF transformers L14, L19, to broaden their pass band.

#### CRYSTAL FILTER

a. *Controls:* The Quartz Crystal Filter (T1) couples the 1st detector (V3) to the 1st IF amplifier (V5). Its selectivity can be varied in definite steps by the CRYSTAL SELECTIVITY switch (S2) controlled from the front panel by knob and pointer. In addition, its selectivity characteristic can be greatly sharpened *on one side* or the other (to avoid heterodyne "whistle") by adjusting the PHASING capacitor (C46), also controlled by a knob on the front panel.

b. *Variable Selectivity:* Curves A and B, Fig. 8, show Receiver selectivity curves which indicate certain effects of the Crystal Filter. When the CRYSTAL SELECTIVITY switch is set at OFF, the quartz crystal is short-circuited and signal voltages present in the secondary of the 1st detector plate coil (L26) are impressed directly on the control grid of the first IF amplifier tube (V5). At any other setting (1 to 5), the quartz crystal is in use and acts as an extremely high "Q," high impedance, series tuned circuit interposed between the secondary of plate coil L26 and the 1st IF grid circuit (L27, C48), which constitutes the load into which the crystal

works. Selectivity is varied by altering the impedance of this parallel tuned circuit (L27, C48), which is accomplished by adding resistance. (R17, R18, R19, R20) in series with coil L27 and capacitor C48.

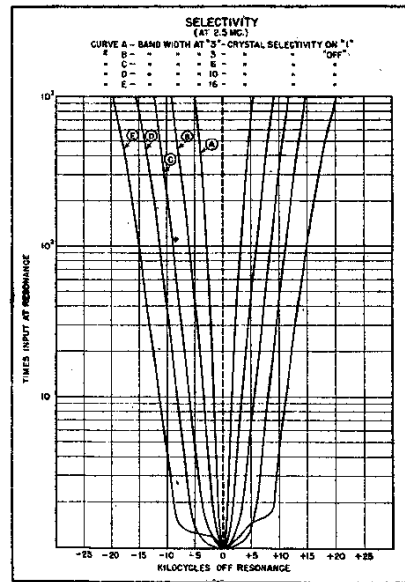

Fig. 8—Selectivity curves.



### AVC AMPLIFIER AND RECTIFIER

Special amplifier and rectifier stages are employed in order to give most satisfactory AVC action. AVC voltages are applied to the two RF stages and to the first two IF stages and compensate for variations in signal strength due to fading. A different rate of compensation is required for voice modulated signals than for code signals. This is automatically adjusted when the beat frequency oscillator is turned on or off.

### BEAT OSCILLATOR

The beat oscillator tube (V10) and associated oscillator circuit (T5) provide a voltage at approximately the intermediate frequency. This voltage, when introduced into the input circuit of the 2nd detector (V8) by means of a small coupling capacitor (C60), mixes with the I-F signal being delivered to the detector by the 3rd I-F amplifier (V7). The mixture of these two similar frequencies results in a "beat" or difference frequency in the output of the 2nd detector. The beat oscillator frequency is adjusted so that the pitch of this difference frequency falls within the audio-frequency range. Fine adjustment of the beat frequency pitch is accomplished by means of the BEAT OSCILLATOR control on the front panel which turns a small variable capacitor (C69) in transformer T5. The beat oscillator is turned on by throwing the SIGNAL-MOD-CW switch (S4) to CW. In addition to being necessary for proper reception of CW signals, the beat oscillator is useful for locating weak signals of any kind.

### AF AMPLIFIER

a. *Circuits:* The AF amplifier has three stages, using one 6J5 triode (V13) and three 6F6 pentodes (V14, V15, V16). The grid of the first tube (V13) is connected to the moving arm of the AUDIO GAIN control (R48) through a blocking capacitor (C82). Its plate is coupled to the grid of the second AF amplifier by means of capacitor C83, plate resistor R53 and grid leak R54. The second amplifier tube (V14), while a pentode, is operated as a triode by connecting its plate and screen together. It drives the output tubes (V15, V16) through a push-pull input transformer (T7). The output tubes (V15, V16) are also triode-connected pentodes and are operated as class AB<sub>2</sub> amplifiers.

b. *Output Transformer:* The output transformer (T8) has two secondary windings; a 500-ohm secondary (4-5) for power output, and a secondary for earphones (6-7) designed to deliver about 3% of the output power into an 8000-ohm resistive load when the 500-ohm sec-

ondary is connected to a matching load such as the loudspeaker

The turns ratio and resistance of the earphone winding are such that the power delivered to any load between 8000 ohms and 80 ohms varies less than 6 db, and the power input to a 250-ohm load is but 2 db greater than that to a 4000-ohm load. Fig. 16 shows curves of overall audio fidelity with different settings of the CRYSTAL SELECTIVITY and BAND WIDTH controls.

### POWER SUPPLY

The Power Supply furnishes "A," "B" and "C" voltages for the Receiver. The "A," or heater voltage, is 6.3 volts AC obtained from a separate secondary winding (1-2) on the power transformer (T1, Fig. 10). "B" voltage is obtained from the center-tapped high-voltage secondary (7-8-10) connected to the plates of the "B" rectifier tube (V1). After this voltage is rectified, it is filtered by the combined action of the first filter choke (L1) and the two filter capacitors C1 and C2. This provides 380 volts DC for the plates of the power output tubes in the Receiver. Further filtering by the second filter choke (L2) and the first two sections of capacitor C3 provides 250 volts DC for the plates of the remaining tubes in the Receiver. Approximately 100 volts DC for the screen grids of the Receiver tubes is obtained from the tap on the bleeder resistor (R1), which is by-passed by the remaining section of capacitor C3. Negative "C" voltage is obtained from a tap (9) on the high-voltage secondary connected to the filament of the "C" rectifier tube (V2). The rectified output from the plates of tube V2 is filtered by the three sections of resistor R2 and the three sections of filter capacitor C4. When connected to the Receiver, the voltage at the end of this filter is approximately minus 50.

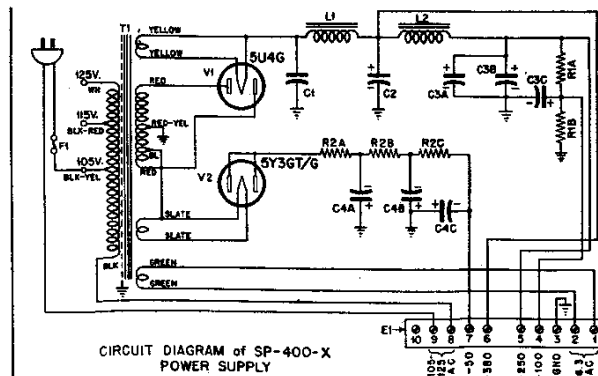

FIG. 10—  
Power supply  
diagram.

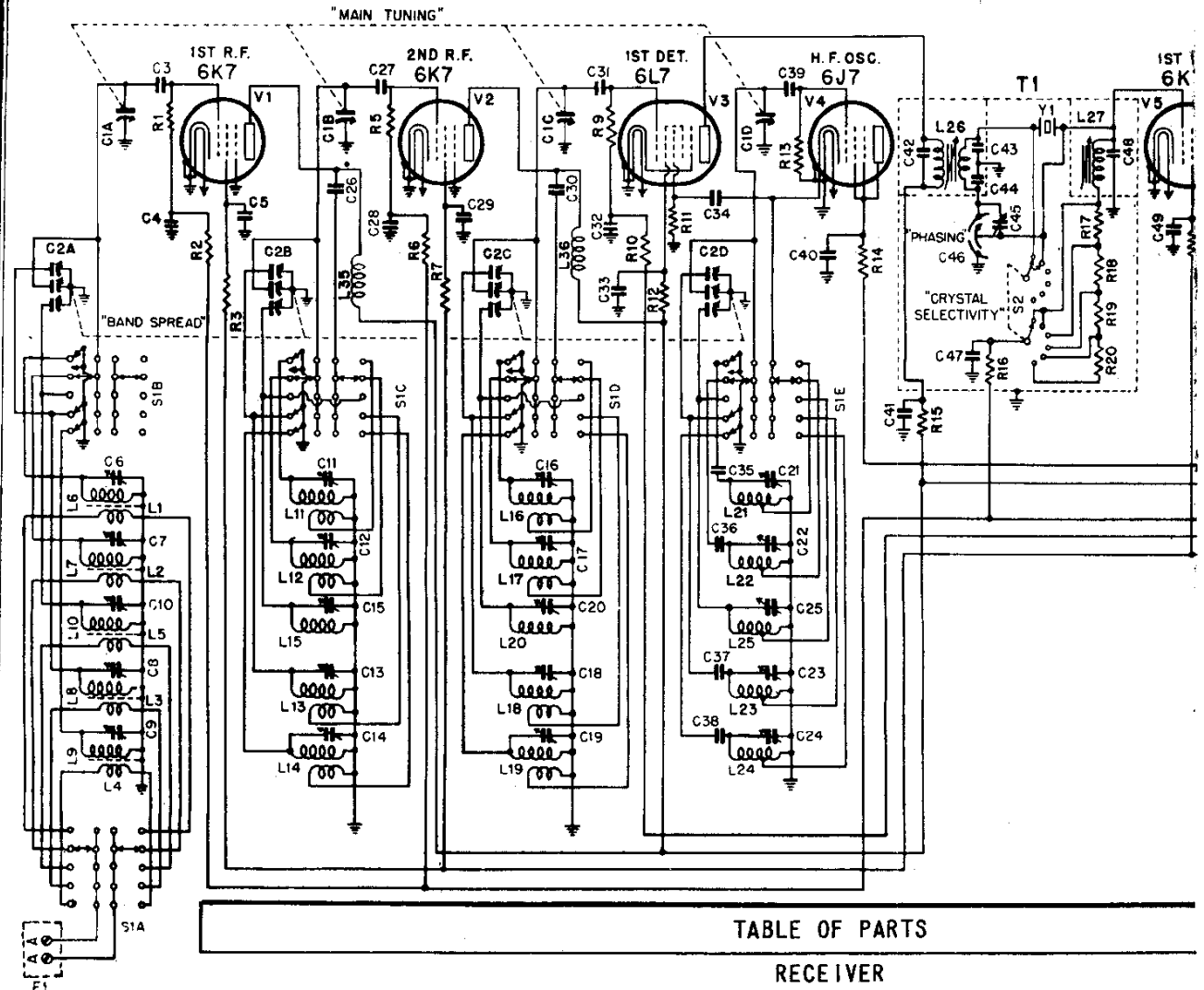

TABLE OF PARTS

RECEIVER

CIRCUIT REF. NO.	DESCRIPTION	PART NO.				
<b>CAPACITORS</b>						
C1	Main Tuning			C17	Trimmer, Mica, 3-30 mmf	Part of SA-114
C2	Band Spread			C18	Trimmer, Mica, 3-30 mmf	Part of SA-117
C3	620 mmf, Mica	23005-86		C19	Trimmer, Mica, 3-30 mmf	Part of SA-137
C4	.02 mf, Paper	23912-1		C20	Trimmer, Air, 4-16 mmf	Part of SA-131
C5	.05 mf, Paper	23912-2		C21	Trimmer, Air, 4-28 mmf	Part of SA-112
C6	Trimmer, Mica, 3-30 mmf	Part of SA-110		C22	Trimmer, Air, 4-28 mmf	Part of SA-115
C7	Trimmer, Mica, 3-30 mmf	Part of SA-113		C23	Trimmer, Air, 4-28 mmf	Part of SA-118
C8	Trimmer, Mica, 3-30 mmf	Part of SA-116		C24	Trimmer, Air, 4-28 mmf	Part of SA-138
C9	Trimmer, Mica, 3-30 mmf	Part of SA-136		C25	Trimmer, Air, 4-25 mmf	Part of SA-132
C10	Trimmer, Air, 4-36 mmf	Part of SA-130		C26	300 mmf, Silver Mica	23003-105D
C11	Trimmer, Mica, 3-30 mmf	Part of SA-111		C27	620 mmf, Mica	23005-86
C12	Trimmer, Mica, 3-30 mmf	Part of SA-114		C28	.02 mf, Paper	23912-1
C13	Trimmer, Mica, 3-30 mmf	Part of SA-117		C29	.05 mf, Paper	23912-2
C14	Trimmer, Mica, 3-30 mmf	Part of SA-137		C30	300 mmf, Silver Mica	23003-105D
C15	Trimmer, Air, 4-16 mmf	Part of SA-131		C31	620 mmf, Mica	23005-86
C16	Trimmer, Mica, 3-30 mmf	Part of SA-111		C32	.02 mf, Paper	23912-1
				C33	.05 mf, Paper	23912-2
				C34	95 mmf, Silver Mica	6195
				C35	4800 mmf, "Toothpick"	Part of SA 112
				C36	2400 mmf, "Toothpick"	Part of SA 115

"Clarified Schematics"

© John F. Rider

BAND-SWITCH SHOWN AT 3rd POSITION CLOCKWISE 5 to 10 Mc. \* STARS SHOW CHANGES IN PARTS DESIGNATIONS FOR 3rd POSITION - OTHERWISE SCHEMATIC REMAINS THE SAME AS 4th POSITION.

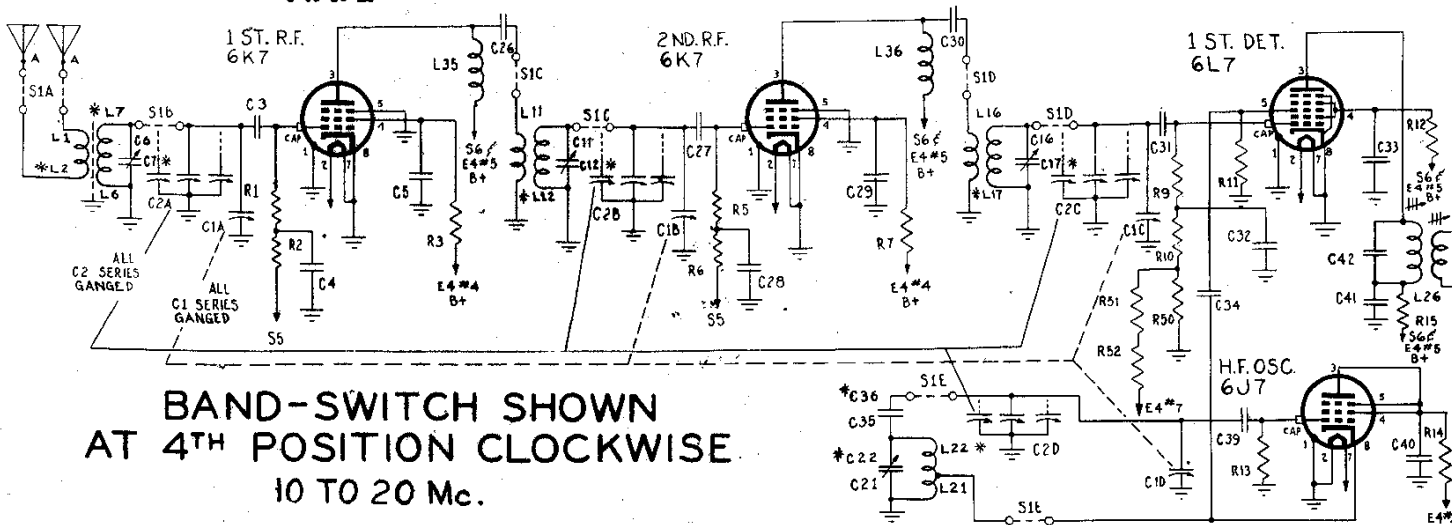

BAND-SWITCH SHOWN AT 4th POSITION CLOCKWISE 10 TO 20 Mc.

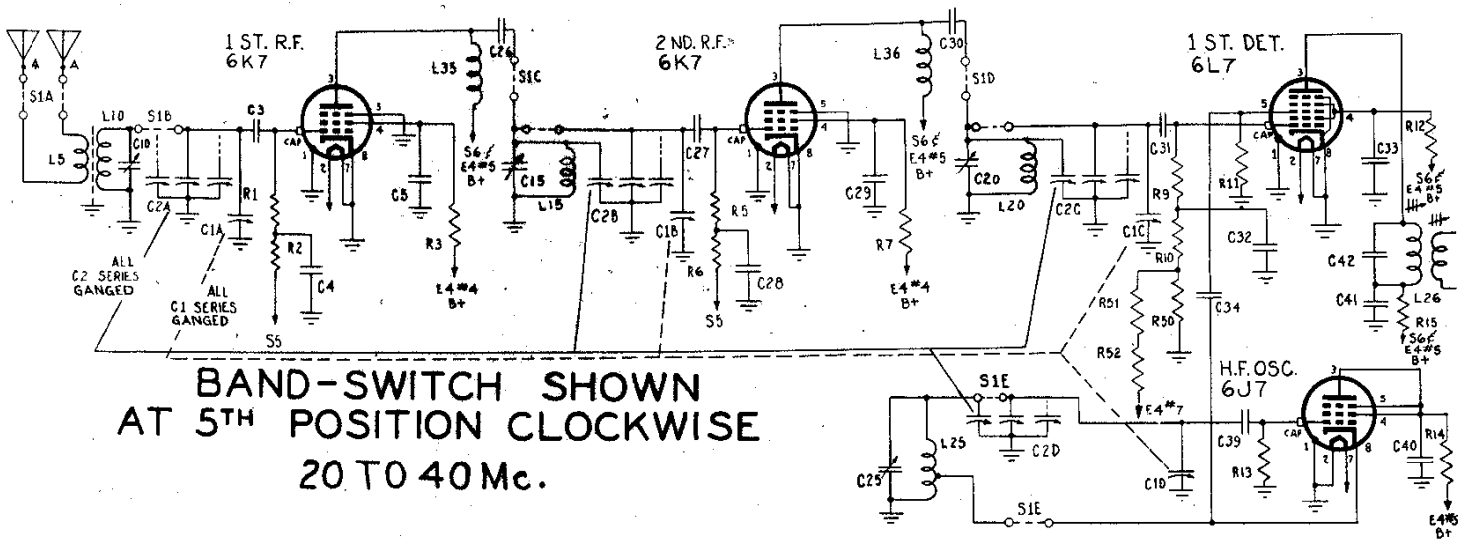

BAND-SWITCH SHOWN AT 5th POSITION CLOCKWISE 20 TO 40 Mc.

## ALIGNMENT - GENERAL

When either selectivity or sensitivity or both appear to be below normal and all tubes have been tested, check the alignment. Remove the cabinet or dust cover and bottom cover plate of the Receiver to get at all parts for making adjustments. CAUTION: ANY CHANGES FROM ORIGINAL SETTINGS WILL BE SMALL SO USE GREAT CARE WHEN CHECKING ADJUSTMENTS. This is especially true of the H-F oscillator circuits, which should NOT be disturbed unless the MAIN TUNING dial is definitely known to be off calibration.

a. *Signal Generator* - This should be an accurately calibrated instrument producing amplitude-modulated radio-frequency signals. In addition to 465 kc (the I.F.), the frequency range required of the signal generator depends on the tuning range of the receiver to be aligned. The R-F alignment frequencies required for the Series 400-SX Super-Pro are shown in Fig. 13. The second harmonic can generally be used when the fundamental frequency is not available. For example: a signal generator covering all frequencies from 465 kc to 20 mc could be used to check the highest frequency band by using the second harmonic of 20 mc to provide the 40 mc called for in Fig. 13. The signal generator should have an output of approximately 100 microvolts and an output impedance of approximately 100 ohms for best results when aligning the R-F and H-F-Oscillator circuits. For I-F alignment these values are not critical. The frequency calibration of the signal generator is extremely important if the Receiver dial calibration is to be correct.

b. *Output Meter* - The output meter should respond to the modulation frequency of the signal generator, preferably 400 cps, and should provide at least half-scale deflection for 10 volts. Its resistance should be greater than 500 ohms.

c. *Tools* - An insulated screwdriver 9/64" wide and .025" thick at the bit, is required for alignment of the Receiver.

d. *Preliminary Procedure* - Throw the OFF-ON switch to ON and let the Receiver warm up for about an hour before beginning adjustments. Connect the output meter to the 500-ohm terminals located at the rear of the Receiver chassis.

## ALIGNMENT PROCEDURE

a. *Preliminary Setup* - Adjust the signal generator to approximately 465 kc and connect its output to the control grid cap of the 1st detector tube (V3) through a fixed capacitor (anything larger than 100 mmf will do). Set the front panel controls as follows:

SENSITIVITY.....0  
 AVC-MANUAL.....MANUAL  
 SIGNAL-MOD-CW.....MOD  
 SEND-REC.....REC  
 BAND SWITCH.....2.5-5.0 mc  
 AUDIO GAIN.....10  
 CRYSTAL SELECTIVITY.....OFF  
 PHASING.....on arrow  
 BAND WIDTH.....3  
 BAND SPREAD DIAL.....100

b. *I-F Alignment Check* -

(1) Set the MAIN TUNING dial near 2.5 mc, but be careful not to tune in a powerful local signal. Set the CRYSTAL SELECTIVITY switch on 3, the AVC-MANUAL switch on AVC, and advance the SENSITIVITY to 10. Turn off the modulation of the signal generator and adjust its frequency slightly to produce maximum deflection of the "S" meter. The adjustment of the signal generator in this manner is necessary in order to get exact agreement with the natural period of the particular quartz crystal in the Receiver being checked. After reducing SENSITIVITY to 0, the modulation may be switched on, but the tuning adjustment of the signal generator must not be altered until the alignment check has been completed. Return the CRYSTAL SELECTIVITY and AVC-MANUAL controls to their original settings of OFF and advance the SENSITIVITY control until a suitable output meter reading is obtained. A half-scale reading in the region of 5 to 10 volts will be satisfactory.

(2) Now check the alignment of both upper (grid) and lower (plate) air trimmer capacitors in I-F transformers T2 and T3 and the single trimmer in T4 for peak reading of the output meter. If one or more of these adjustments results in a sizeable increase in output, reduce the SENSITIVITY control enough to bring the meter reading back to half-scale. Alignment of the plate circuit of the crystal filter (T1) can be tested in the same way by means of the lower adjusting screw on the side of the unit. This screw varies the

position of the powdered iron core in coil L26. Do not change the setting of the upper adjusting screw which tunes grid coil L27, as this circuit cannot be adjusted properly with the output meter. It can, however, be aligned by the "visual" method using a frequency-modulated signal generator and cathode-ray oscilloscope. If this equipment is available, proceed as follows:

(3) Connect the input of the vertical amplifier of the oscilloscope to the PHONO connections on terminal strip E3 (Fig. 6) on the rear skirt of the Receiver chassis. The "high" terminal is the second one from the edge of the strip; the first screw is connected to the chassis. Set the frequency-modulated signal generator to approximately 465 kc and connect its output to the control grid cap of the 1st detector (V3) through a fixed capacitor (100 mmf or larger). With the CRYSTAL SELECTIVITY switch at OFF, readjust the signal generator frequency to produce the conventional single-peaked resonance curve on the screen of the oscilloscope. Then turn the CRYSTAL SELECTIVITY switch to position 1. If the grid coil (L27) is correctly tuned the image on the oscilloscope screen will remain symmetrical but will be only about two-thirds as wide as before, indicating an increase in selectivity. The oscilloscope image is also affected by the PHASING control, maximum symmetry occurring at or very near the arrow on its scale. Therefore, when tuning L27, rock the PHASING control back and forth at the same time to secure the best adjustment.

c. *AVC Alignment Check* - Leaving all other controls as in PAR. 26a, and without changing the signal generator frequency, reduce AUDIO GAIN to 0, switch to AVC and increase SENSITIVITY to 10. Increase AUDIO GAIN to restore half-scale reading on the output meter and adjust the single trimmer capacitor in T6 for minimum output meter reading. The "S" meter reading should "peak" at the same time the output meter reading "dips".

d. *Beat Oscillator Alignment Check* - Continuing with controls as above (PAR. 26c), switch off the output meter and plug in a pair of earphones, or replace the meter with a suitable loudspeaker. Turn the SIGNAL-MOD-CW switch to CW and see that the BEAT OSCILLATOR control is exactly on 0 (zero). If tone in earphones or speaker is not

very low in pitch, readjust the trimmer capacitor near the bottom of T5 until it is. If the beat oscillator is in perfect alignment when this test is made, no sound will be heard since the signal generator and the beat oscillator will be oscillating at the same frequency and there will be no audible difference of "beat". Check this by turning the BEAT OSCILLATOR control knob slightly off 0 (zero) toward one side or the other. If this results in a tone rising in pitch as the pointer is turned away from 0 (zero) to either side, the beat frequency oscillator is perfectly aligned. If no audible tone can be obtained within the range of the BEAT OSCILLATOR control, adjust the trimmer capacitor near the bottom of T5 until an approximate "zero beat" occurs at 0 (zero) setting of the BEAT OSCILLATOR control.

e. *H-F Oscillator Calibration Check* - The accuracy of the MAIN DIAL calibration depends solely on the H-F oscillator frequency, which in this Receiver is 465 kc (the IF) higher than the signal frequency except in the 20-40 mc band, where the H-F oscillator is 465 kc lower than the signal frequency. Although the frequency of the H-F oscillator can be measured directly if accurate frequency-measuring equipment is on hand, it is far simpler to check it by tuning in signals of known frequency and noting the MAIN DIAL readings. CAUTION: BE SURE THE BAND SPREAD DIAL IS SET AT 100 WHEN MAKING THIS TEST.

(1) To correct dial calibration, refer to alignment chart (Fig. 13) for location of H-F oscillator adjustments as well as signal frequencies at which settings should be made. If the 2.5-5.0 mc band is to be corrected, the signal generator may be set accurately to 2.5 mc and its second harmonic (if strong enough) used for the 5.0 mc end of the band. The output of the signal generator should be unmodulated and SIGNAL-MOD-CW switch on Receiver turned to CW. Set BEAT OSCILLATOR at 0, AUDIO GAIN at 10, AVC-MANUAL on MANUAL, BAND WIDTH at 16. Disconnect output meter and use earphones or loudspeaker to make necessary adjustments by "zero beat" method. Connect signal generator to antenna terminals for this test.

(2) Tune in second harmonic at 5.0 mc end of dial to zero beat. Notice approximate dial error. Turn main dial slightly toward 5.0 mc calibration line until beat note rises to a high pitch. Do not turn dial far enough to

raise beat so high it cannot be heard. With alignment screwdriver adjust trimmer capacitor marked HF OSC 5.0 mc (Fig. 13) until beat is again zero. Turn main dial still farther toward 5.0 mc line and make a further adjustment of trimmer capacitor to return to zero beat. Repeat this process as often as necessary to bring dial to exactly 5.0 mc. (The main dial could be set at once on exactly 5.0 mc and trimmer turned enough at one time to produce zero beat, but the step-by-step method is recommended.) Now tune in 2.5 mc fundamental at low-frequency end of main dial and correct the calibration step-by-step as before, using inductance trimming adjustment HF OSC 2.5 mc (Fig. 13). When second harmonic is again tuned in at other end of dial, it will be found that inductance adjustment at 2.5 mc has changed correction previously made at 5.0 mc. This is normal. Go back and forth several times from 2.5 to 5.0 mc in order to bring both ends of dial scale into exact agreement with the signal frequency. CAUTION: DURING THIS ADJUSTMENT BE VERY CAREFUL TO ADJUST THE SENSITIVITY CONTROL TO AVOID OVERLOADING.

f. R-F and 1st Detector Alignment Check - Although alignment of these three circuits (1st and 2nd RF and 1st Det) can be checked at the same time as the H-F oscillator, it is simpler to consider each check as a separate operation. Efficient weak-signal reception, with low receiver noise level and high image rejection ratios, depends on the relative alignment of these three circuits with respect to the H-F oscillator and without regard to calibration accuracy.

(1) Accurate calibration of the signal generator is not required to check these adjustments. Modulation of the signal generator, while convenient, is not strictly necessary. Input to antenna terminals should be through 100 ohms (approximate) including out-

put resistance of signal generator. If signal generator is modulated, Receiver controls should be set as for I-F alignment; if unmodulated, set BEAT OSCILLATOR to 2 (either side) and SIGNAL-MOD-CW to CW. Adjust SENSITIVITY for half-scale reading on output meter when signals are exactly in tune.

(2) Starting with 2.5-5.0 mc band, set main dial at 5.0 mc (BAND SPREAD at 100) and adjust frequency of signal generator for peak deflection of output meter. Then check setting of trimmer marked 1st DET 5.0 mc (Fig. 13). Repeat this procedure on trimmers designated as 2nd RF and 1st RF in same row. If readjustments on one of these settings greatly increases output meter reading, alter SENSITIVITY slightly to reduce reading to half-scale. After each adjustment check tuning of Receiver to make sure test signal is still accurately tuned. BAND SPREAD may be used as a vernier for this purpose. CAUTION: THIS TUNING CHECK IS EXTREMELY IMPORTANT AT HIGH END OF 10-20 MC AND 20-40 MC BANDS WHERE THERE IS SOME SLIGHT INTERACTION BETWEEN 1ST DET AND H-F OSC CIRCUITS. After checking the three trimmers at high end of this band, turn main dial to 2.5 mc and retune signal generator to suit. Then check the three inductance adjuster settings marked 2.5 mc (Fig. 13) in the same row. Since adjustments at one end of a band also affect the other end of the band (as described under H-F OSC alignment), repeat above procedure until no further improvement can be secured. The number of repetitions necessary depends on how much mistuning existed initially. Other bands may be checked in the same manner.

(3) For best possible efficiency with a particular antenna arrangement, the 1st RF circuits may be adjusted with the antenna connected. This can be done by loosely coupling output of signal generator to antenna

system instead of directly to antenna terminals through a 100-ohm resistor. Make sure that signal from signal generator actually reaches Receiver by way of antenna rather than by some form of direct coupling.

(4) In all the foregoing tests using output meter readings for circuit adjustment it is recommended that earphones (or speaker) be used to monitor the signal. This will avoid false adjustments caused by overloading or freakish responses.

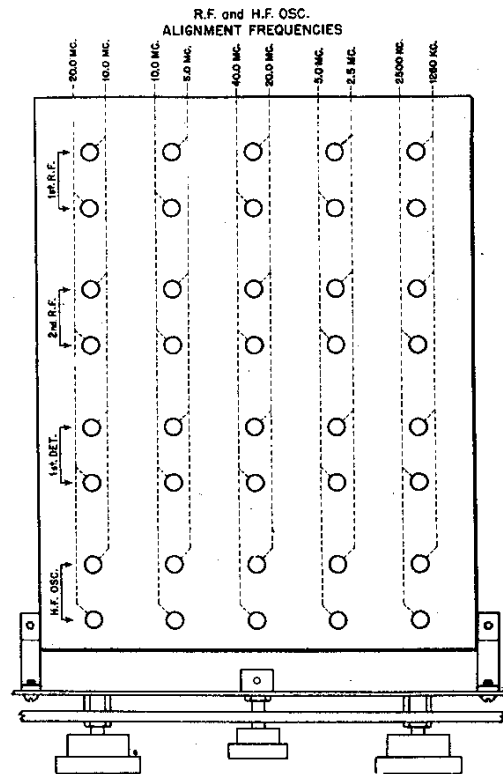

Fig. 13. ALIGNMENT CHART. Shows location of screwdriver adjustments and corresponding test frequencies.

HAMMARLUND MFG. CO. INC.

MODEL SP-400-SX

CIRCUIT REF. NO.	DESCRIPTION	PART NO.	CIRCUIT REF. NO.	DESCRIPTION	PART NO.	CIRCUIT REF. NO.	DESCRIPTION	PART NO.
C76	5100 mf, mica	23015-16		<b>METERS</b>				
C77	.05 mf, Paper	23912-2	M1	Meter, 0-200 micro-ampere movement	4903	V1, V2, V5	6K7	16244-1
C78	.05 mf, Paper	23912-2				V3	6L7	16212-1
C79	.05 mf, Paper	23912-2				V4	6J7	16220-1
C80	.05 mf, Paper	23912-2		<b>RESISTORS</b>		V5, V7, V11	6SK7	16245-1
C81	.05 mf, Paper	23912-2	R1	500,000 ohms, 1/3 W	4959	V8, V12	6H6	16202-1
C82	.02 mf, Paper	23912-1	R2	10,000 ohms, 1/2 W	19309-73	V9	6N7	16246-1
C83	.05 mf, Paper	23912-2	R3	2,000 ohms, 1/2 W	19301-206	V10	6SJ7	16236-1
C84	40 mf, Electrolytic, Dry	6171	R4	Not used		V13	6J5	16209-1
C85	.25 mf, Paper	23912-38	R5	500,000 ohms, 1/3 W	4959	V14, V15, V16	6F6	16239-1
C86	.25 mf, Paper	23912-38	R6	10,000 ohms, 1/2 W	19309-73			
			R7	2,000 ohms, 1/2 W	19301-206			
			R8	Not used				
	<b>JACK</b>		R9	500,000 ohms, 1/3 W	4959	W1	Connector, nine wire, with two 10 terminal connector strips.	SA-35
J1	JX-34-A, Phone Jack (Headset)	5066	R10	10,000 ohms, 1/2 W	19309-73	W2	Connector, eight wire, with one 10 terminal connector strip (special order only)	SA-67
	<b>COILS</b>		R11	50,000 ohms, 1/3 W	4960			
L1	Coil Assen., Antenna Primary, 10-20 mc	SA-46	R12	24,000 ohms, 2 W	19304-202			
L2	Coil Assen., Antenna Primary, 5-10 mc	SA-47	R13	50,000 ohms, 1/3 W	4960			
L3	Coil Assen., Antenna Primary, 2.5-5 mc	SA-48	R14	12,000 ohms, 2 W	19304-44			
L4	Coil Assen., Antenna Primary, 1250-2500 kc	SA-49	R15	2,000 ohms, 1/2 W	19301-206			
L5	Coil Assen., Antenna Primary, 20-40 mc	SA-46	R16	10,000 ohms, 1/2 W	19309-73			
L6	Coil Assen., Grid Coil, 10-20 mc	SA-110	R17	24 ohms, 1/2 W	19301-178	X1-X8	Tube socket, molded octal, low loss bakelite.	16082-1
L7	Coil Assen., Grid Coil 5-10 mc	SA-113	R18	51 ohms, 1/2 W	19301-187	X5-X16	Molded octal, black bakelite	16083-1
L8	Coil Assen., Grid Coil, 2.5-5 mc	SA-116	R19	300 ohms, 1/2 W	19301-196		<b>QUARTZ CRYSTAL</b>	
L9	Coil Assen., Grid Coil, 1250-2500 kc	SA-136	R20	2,000 ohms, 1/2 W	19301-206	Y1	Resonator type, ground for 465 kc	4944
L10	Coil Assen., Grid Coil, 20-40 mc	SA-130	R21	2,000 ohms, 1/2 W	19301-206			
L11	Coil Assen., R.F. Transformer, 10-20 mc	SA-111	R22	2,000 ohms, 1/2 W	19301-206		<b>POWER SUPPLY</b>	
L12	Coil Assen., R.F. Transformer, 5-10 mc	SA-114	R23	10,000 ohms, 1/2 W	19309-73		<b>CAPACITORS</b>	
L13	Coil Assen., R.F. Transformer, 2.5-5 mc	SA-117	R24	2,000 ohms, 1/2 W	19301-206	C1	Paper 1 mf, 1000 VDCW	23043-4
L14	Coil Assen., R.F. Transformer, 1250-2500 kc	SA-137	R25	2,000 ohms, 1/2 W	19301-206	C2	16 mf, 600 VDCW, Dry Electrolytic	23042-13
L15	Coil Assen., R.F. Transformer, 20-40 mc	SA-131	R26	10,000 ohms, 1/2 W	19309-73	C3-A-B-C	8-8-8 mf, 450 VDCW Dry Electrolytic	23042-28
L16	Coil Assen., Same as L11	SA-111	R27	51,000 ohms, 1 W	19303-182	C4-A-B-C	8-8-8 mf, 450 VDCW Dry Electrolytic	23042-28
L17	Coil Assen., Same as L12	SA-114	R28	2,000 ohms, 1/2 W	19301-206			
L18	Coil Assen., Same as L13	SA-117	R29	100,000 ohms, 1/2 W	19301-215	E3	<b>FUSE HOLDER</b>	15923-1
L19	Coil Assen., Same as L14	SA-137	R30	75,000 ohms, 1/2 W	19301-215	F1	<b>FUSE</b> 2 amp 250V, glass enclosed	15928-7
L20	Coil Assen., Same as L15	SA-131	R31	51,000 ohms, 1/2 W	19301-171			
L21	Coil Assen., Oscillator Coil, 10-20 mc	SA-112	R32	1 megohm, 1/2 W	19301-104	L1	<b>CHOKES</b>	
L22	Coil Assen., Oscillator Coil, 5-10 mc	SA-115	R33	240,000 ohms, 1/2 W	19301-105	L2	Filter, 350 ohms, 25h at 160 mc	2981
L23	Coil Assen., Oscillator Coil, 2.5-5 mc	SA-118	R34	4 ohms, 5 W	19431-1			
L24	Coil Assen., Oscillator Coil, 1250-2500 kc	SA-138	R35	100,000 ohms, 1/2 W	19301-80	R1	18,000 ohms tapped at 9500, 10 W	4946
L25	Coil Assen., Oscillator Coil, 20-40 mc	SA-132	R36	510,000 ohms, 1/2 W	19309-159	R1A	8500 ohms	Part of R1
L26	Coil, Universal, 7/41 Litz., iron dust core	6146	R37	5,100 ohms, 1/2 W	19301-210	R1B	9500 ohms	Part of R1
L27	Coil, Universal, 7/41 Litz., iron dust core	6147	R38	51,000 ohms, 1/2 W	19301-171	R2	18,000 ohms tapped at 6500, 6500, 10 W	3997
L28	Coil, 3 ple universal, 7/41 Litz., ceramic core	2903-A	R39	51,000 ohms, 1 W	19301-171	R2A	5000 ohms	Part of R2
L29	Coil, 3 ple universal, 7/41 Litz., ceramic core	3990	R40	51,000 ohms, 1 W	19303-182	R2B	6500 ohms	Part of R2
L30	Coil, Same as L28	2903-A	R41	1,000 ohms, Potentiometer	4922	R2C	6500 ohms	Part of R2
L31	Coil, Same as L29	3990	R42	2,000 ohms, 1/2 W	19301-206	T1	<b>TRANSFORMER</b> , 50-60 cycle, primary tapped at 105, 115, 125 V	4801
L32	Coil, Universal, 7/41 Litz., ceramic core	4907	R43	24,000 ohms, 1/2 W	19301-213			
L33	Coil, 3 ple universal, 7/41 Litz., ceramic core	2951	R44	10,000 ohms, 1/2 W	19309-73		<b>TUBES</b>	
L34	Coil, Universal, 7/41 Litz., ceramic core	4806	R45	1 megohm, 1/2 W	19301-104	V1	504G	16215-1
L35	Choke coil, 5 ple universal R.F. Choke, ceramic core, wire leads	609-1	R46	2 megohms, 1/2 W	19301-169	V2	5Y3GT/G	16262-1
L36	Choke Coil, Same as L35	609-1	R47	50,000 ohms, Potentiometer	5023	W1	<b>CABLE</b> , Power	6143
			R48	4 ohms, 5 W	19431-1	X1, X2	<b>TUBE SOCKET</b> , Molded octal, black bakelite	16083-1
			R49	250,000 ohms, Potentiometer	4919			
			R50	510,000 ohms, 1/2 W	19309-159			
			R51	300 ohms, 1/2 W	19301-196			
			R52	1,800 ohms, 1/2 W	19301-38			
			R53	3,000 ohms, 1 W	19303-169			
			R54	51,000 ohms, 1 W	19303-182			
			R55	510,000 ohms, 1/2 W	19309-159			
			R56	750 ohms, 10 W	19430-30			
				<b>SWITCHES</b>				
			S1	10 pole, 5 position, 5 section				
			S2	Wafer type, six position	4911			
			S3	SPST Rotary Snap	4916			
			S4	SPST Rotary Snap	5733			
			S5	DPDT Toggle	2990			
			S6	SPST Rotary Snap	5729			
			S7	DPST Toggle	2983-1			
				<b>FILTER</b>				
			T1	Assem., Variable selectivity quartz crystal filter	SA-178A			
				<b>TRANSFORMERS</b>				
			T2	Variable selectivity, i.F.	SA-166A			
			T3	Same as T2	SA-166A			
			T4	Fixed selectivity, i.F.	SA-167A			
			T5	465 kc oscillator assem.	SA-169A			
			T6	Fixed selectivity, i.F.	SA-168A			
			T7	A.F. push-pull input	4887			
			T8	A.F. push-pull output	4888			