

Assembly  
and  
Operation  
of the

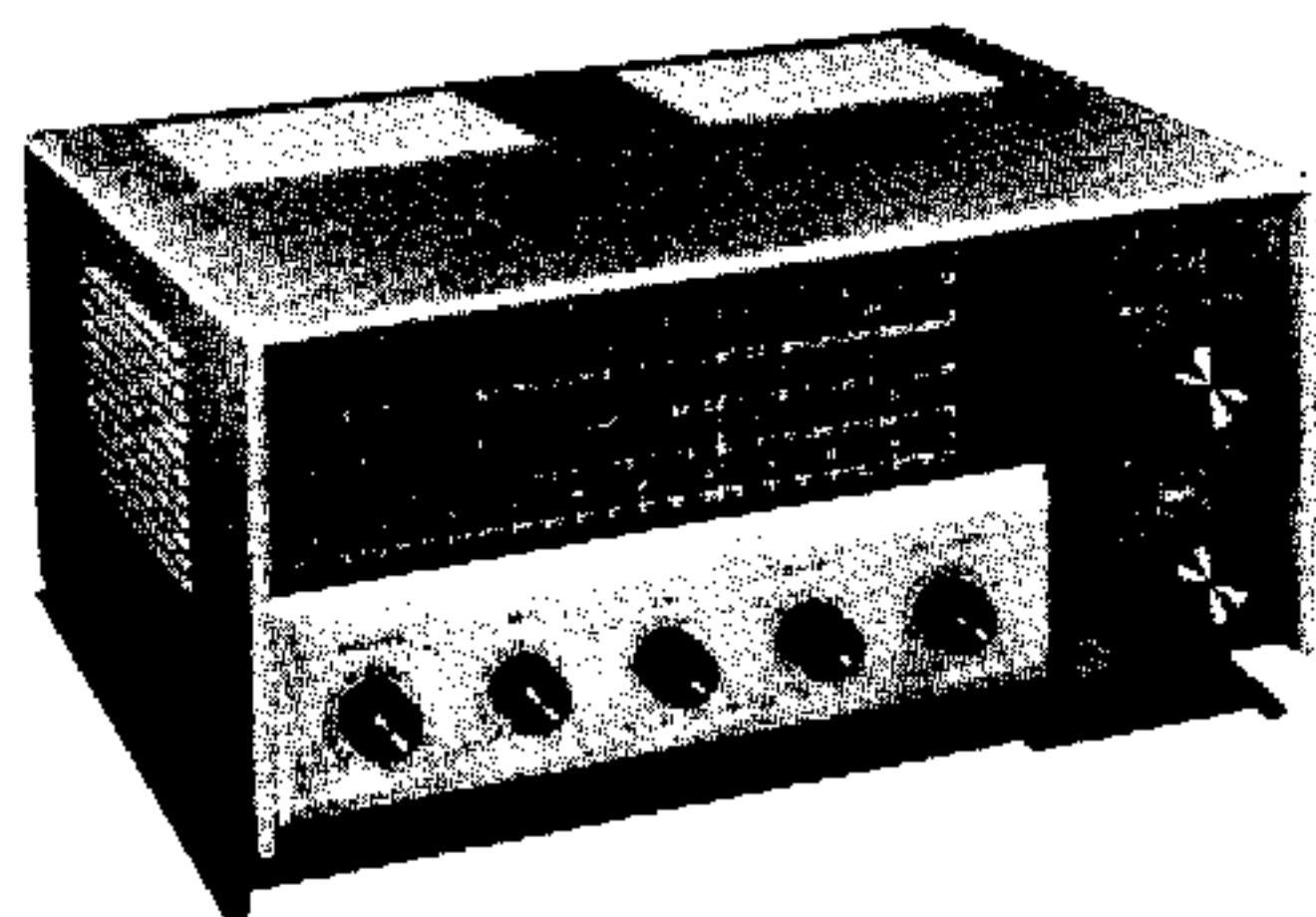

**GENERAL  
COVERAGE  
RECEIVER**  
MODEL GR-91



HEATH COMPANY,  
BENTON HARBOR,  
MICHIGAN



**TABLE OF CONTENTS**

Specifications. . . . .	2
Introduction. . . . .	3
Radio. . . . .	3
Circuit Description. . . . .	4
Construction Notes. . . . .	5
Schematic. . . . .	5*
Parts List. . . . .	6
Proper Soldering Techniques. . . . .	9
Circuit Board Wiring And Soldering. . . . .	10
Step-By-Step Procedure. . . . .	12
 Step-By-Step Assembly. . . . .	 13
Parts Mounting. . . . .	13
Circuit Board Assembly. . . . .	16
Chassis Wiring. . . . .	18
Band Switch Wiring And Installation. . . . .	21
 Initial Test. . . . .	 29
Test And Adjustment. . . . .	29
Adjustment. . . . .	30
Final Assembly. . . . .	30
Operation. . . . .	31
Antenna Installation. . . . .	32
Reception Guide. . . . .	33
In Case Of Difficulty. . . . .	33
Specific Problems. . . . .	34
Alignment With Instruments. . . . .	35
Alignment Chart. . . . .	36
 Service Information. . . . .	 37
Service. . . . .	37
Replacements. . . . .	38
Shipping Instructions. . . . .	39
 Warranty. . . . .	 39

\*Fold-out from page.

All prices are subject to change without notice. The Heath Company reserves the right to discontinue instruments and to change specifications at any time without incurring any obligation to incorporate new features in instruments previously sold.

## SPECIFICATIONS

Frequency Range -	
Band A. . . . .	550 kc to 1600 kc.
Band B. . . . .	1.6 mc to 4 mc.
Band C. . . . .	4 mc to 10 mc.
Band D. . . . .	10 mc to 30 mc.
S Meter. . . . .	Indicates relative signal strength.
Headphone Jack. . . . .	For most commercial headphones (headphone resistance may be from 50 $\Omega$ to 10 K $\Omega$ ).
Controls And Switches. . . . .	VOLUME control with power ON-OFF switch. BFO control with ON-OFF switch. Selector Switch with AM, STBY, and CW positions. BAND switch. ANT TRIM. BAND SPREAD TUNING. MAIN TUNING. ANL (Noise Limiter) ON-OFF switch.
Tube Complement. . . . .	12BE6 oscillator and mixer. 12BA6 IF amplifier and BFO. 12AV6 detector and audio amplifier. 50C5 audio output.
Power Supply. . . . .	Silicon diode used as a half-wave rectifier in conjunction with a power transformer.
Power Requirements. . . . .	105-125 volts, 50/60 cps AC, 30 watts.
Dimensions. . . . .	12-1/4" wide x 5-1/4" high x 8-1/4" deep.
Net Weight. . . . .	9 lbs.
Shipping Weight. . . . .	15 lbs.

## INTRODUCTION

The HEATHKIT Model GR-91 General Coverage Receiver is designed primarily for the general radio listener that is interested in shortwave as well as the standard broadcast band.

The frequency range of the Receiver is from 550 kc to 30 mc in four overlapping bands; standard broadcast band, plus three shortwave bands. A logging scale plus amateur and foreign broadcast frequencies are indicated on the dial.

The Receiver features a signal strength "S"

meter, electrical BAND SPREAD for all four bands, BFO control, Selector Switch, headphone jack, and a 3" x 5" weatherproof speaker.

A large printed circuit board is used for circuit stability and for ease of construction. The transformer-operated power supply uses a silicon rectifier for less heat and more efficiency.

The low-silhouette styling and aqua-beige color combination will prove an attractive addition to any surroundings.

## RADIO

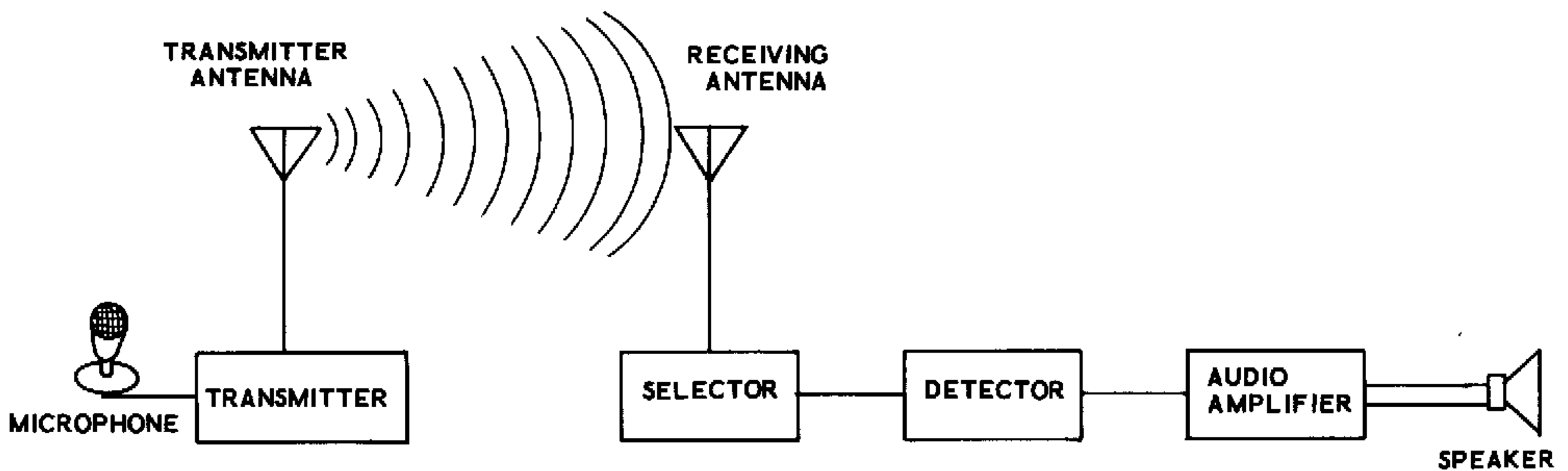

Radio is a means of sending information through space from one point to another, without any wires connecting the two points. The information may be either a sound wave produced by the voice or orchestra, or a wave so interrupted that it is broken into a combination of long and short groups that correspond to the characters of the Morse code.

When an announcer speaks into a microphone in a radio broadcast station, the sound waves created by his voice are picked up by the microphone and changed into electrical impulses. The weak electrical impulses from the microphone are then fed into a transmitter. The transmitter amplifies the weak signals from the microphone and transforms them into an electrical form that can be fed to a broadcast antenna and radiated through space. Similarly, when the amateur radio operator talks into a microphone, the weak electrical impulses from the microphone are fed into a transmitter. The signal from the transmitter is then fed into an antenna and radiated through space.

When these electrical signals leave the transmitting antenna, they are called radio waves. They spread out in all directions, or they may be beamed in one direction, depending on the type of transmitting antenna used.

A receiver antenna picks up a small part of these radio waves and feeds it into the receiver in the form of an electrical signal. Before this signal can enter the receiver, the receiver must be tuned to the transmitted signal.

A receiver must separate one station from another. This is accomplished with tuned circuits which select one station and reject all others. After tuning to the desired radio signal, the radio reduces the frequency of the incoming signal to a constant, intermediate, frequency signal.

The process of obtaining this frequency conversion requires three functions; oscillation, mixing, and detection. An oscillator circuit, generally called a local oscillator, sets up a

signal that differs in frequency from the signal frequency. A mixer is required to obtain a new intermediate frequency by combining the signal frequency with that of the local oscillator through heterodyne or mixing action.

When the incoming radio signal and the oscillator signal are combined, the output of the mixer contains many frequencies. The output of the mixer is fed directly to a highly selective amplifier, called an intermediate frequency or IF amplifier. This IF amplifier accepts only one frequency, amplifies it, and rejects all other frequencies. From the IF amplifier the

signal is fed to the audio detector.

The audio detector separates the audio frequency signal from the IF carrier signal. Therefore, the output of the audio detector is an audio signal. This is where the announcer's voice, or the orchestra is restored to its original form. This signal is very weak.

From the audio detector the audio signal is fed to an audio amplifier which amplifies the signal so it can drive headphones or a loudspeaker. The loudspeaker converts the electrical audio signal into sound waves that can be heard.

## CIRCUIT DESCRIPTION

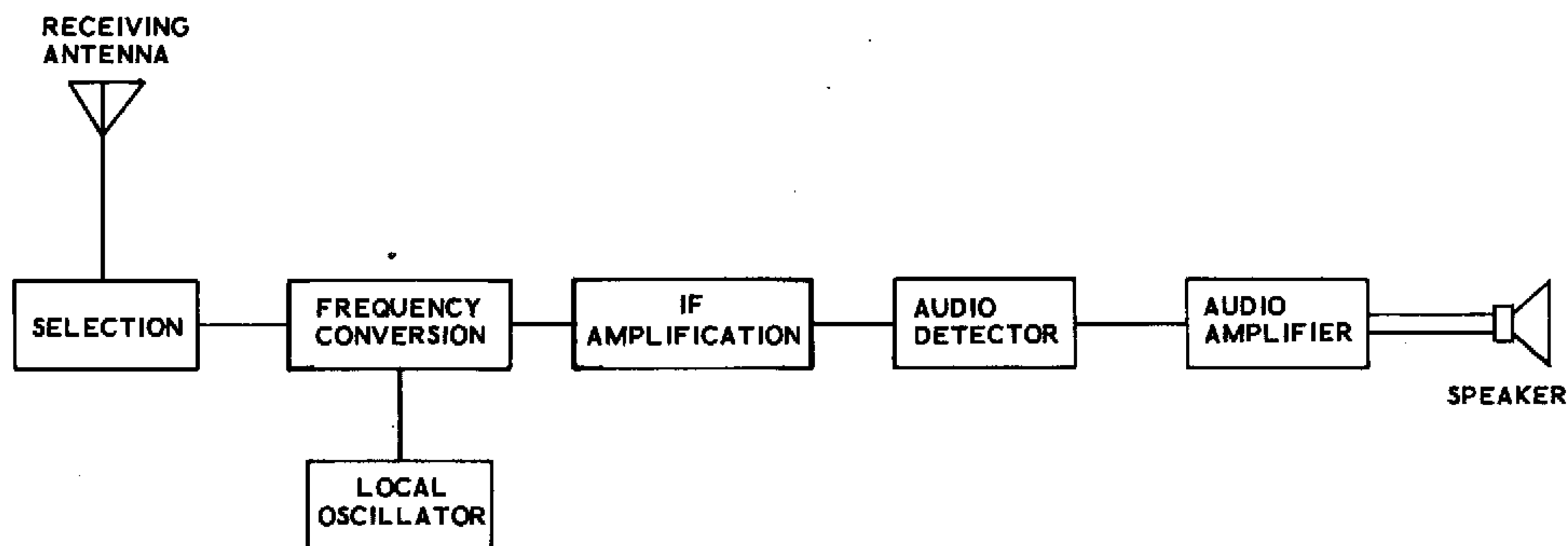

Refer to the Schematic and Block Diagrams to more thoroughly understand the following description.

Assuming the BAND switch to be set for Band A, the signal from the antenna is applied through the BAND switch, coil L4, again through the BAND switch, and is then coupled across capacitor C11 and resistor R1 to the grid of tube V1. Tube V1 is a combination oscillator and mixer.

This tube heterodynes or mixes the incoming signal frequency with the oscillator frequency to obtain a difference frequency of 455 kc. The position of the BAND switch determines which coils and capacitors are used in the oscillator circuit. These coils and capacitors, including the MAIN TUNING capacitor, are used to set the oscillator frequency 455 kc higher than the desired radio

station frequency. The difference frequency of 455 kc is called the intermediate frequency or IF signal.

The signal from the plate of tube V1 is applied through the first IF transformer, IF-1, to the grid of tube V2. IF-1 selects only the 455 kc IF signal and tube V2 amplifies this signal. Tube V2 also acts as a Beat Frequency Oscillator (BFO) to provide an audible signal for Carrier Wave (CW) or Single Side Band (SSB) reception. From the plate of tube V2 the signal is applied through IF-2, which further improves the selectivity of the receiver, to tube V3.

Tube V3 is a combination detector, audio amplifier and Automatic Noise Limiter (ANL). This tube detects the audio signal from the IF signal and amplifies this audio signal. The amount of

audio signal that is fed to tube V3 is controlled by VOLUME control R16. From tube V3 the audio signal is then coupled through capacitor C23 to the grid of tube V4. Tube V4 further amplifies this audio signal and feeds it to the speaker.

The power supply uses silicon diode CR1 as a half-wave rectifier in conjunction with power transformer T1. Filtering of the DC voltages is provided by resistors R21 and R22, and capacitors C24A, C24B, and C24C.

## CONSTRUCTION NOTES

This manual is supplied to assist you in every way to complete your kit with the least possible chance for error. The arrangement shown is the result of extensive experimentation and trial. If followed carefully, the result will be a stable instrument, operating at a high degree of dependability. We suggest that you retain the manual in your files for future reference, both in the use of the instrument and for its maintenance.

**UNPACK THE KIT CAREFULLY AND CHECK EACH PART AGAINST THE PARTS LIST.** In so doing, you will become acquainted with the parts. Refer to the charts and other information on the inside covers of the manual to help you identify the components. If some shortage or parts damage is found in checking the Parts List, please read the Replacement section and supply the information called for therein. Include all inspection slips in your letter to us.

Resistors generally have a tolerance rating of 10% unless otherwise stated in the Parts List.

Tolerances on capacitors are generally even greater. Limits of +100% and -20% are common for electrolytic capacitors.

We suggest that you do the following before work is started:

1. Lay out all parts so that they are readily available.
2. Provide yourself with good quality tools. Basic tool requirements consist of a screwdriver with a 1/4" blade; a small screwdriver with a 1/8" blade; long-nose pliers; wire cutters, preferably separate diagonal cutters; a pen knife or a tool for stripping insulation from wires; a soldering iron (or gun) and rosin core solder. A set of nut drivers and a nut starter, while not necessary, will aid extensively in construction of the kit.

Most kit builders find it helpful to separate the various parts into convenient categories. Muffin tins or molded egg cartons make convenient trays for small parts. Resistors and capacitors may be placed with their lead ends inserted in the edge of a piece of corrugated cardboard until they are needed. Values can be written on the cardboard next to each component. The illustration shows one method that may be used.

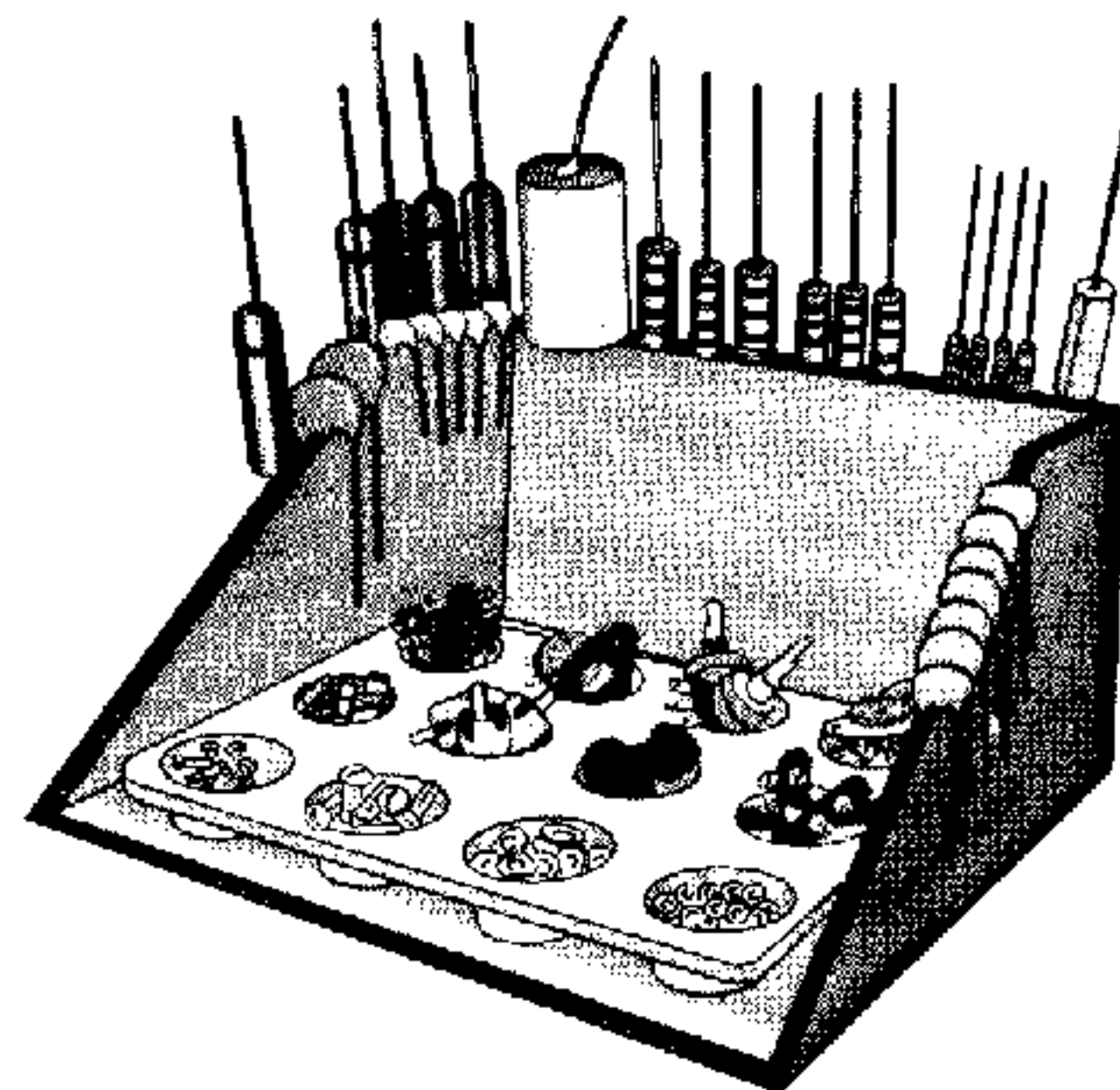

# PARTS LIST

The circled numbers in the Parts List are keyed to the circled numbers on the parts drawings to aid in parts identification.

<u>PART No.</u>	<u>PARTS Per Kit</u>	<u>DESCRIPTION</u>
<b>Resistors</b>		
① 1-3	4 ✓	100 Ω 1/2 watt (brown-black-brown)
1-66	1 ✓	150 Ω 1/2 watt (brown-green-brown)
1-42	1 ✓	270 Ω 1/2 watt (red-violet-brown)
1-9	1 ✓	1000 Ω 1/2 watt (brown-black-red)
1-22	1 ✓	22 KΩ 1/2 watt (red-red-orange)
1-25	1 ✓	47 KΩ 1/2 watt (yellow-violet-orange)
1-60	1 ✓	68 KΩ 1/2 watt (blue-gray-orange)
1-29	1 ✓	220 KΩ 1/2 watt (red-red-yellow)
1-33	2 ✓	470 KΩ 1/2 watt (yellow-violet-yellow)
1-37	1 ✓	2.2 megohm 1/2 watt (red-red-green)
1-38	1 ✓	3.3 megohm 1/2 watt (orange-orange-green)
1-40	1 ✓	10 megohm 1/2 watt (brown-black-blue)
② 1A-11	1 ✓	10 Ω 1 watt (brown-black-black)
1A-18	1 ✓	150 Ω 1 watt (brown-green-brown)
1A-2	1 ✓	1000 Ω 1 watt (brown-black-red)
③ 1B-13	1 ✓	220 Ω 2 watt (red-red-brown)
④ 3E-14	1 ✓	600 Ω 5 watt, wire-wound
⑤ 9-7	1 ✓	880-100 Ω, glo-bar

<u>PART No.</u>	<u>PARTS Per Kit</u>	<u>DESCRIPTION</u>
<b>Capacitors</b>		
21-86	1 ✓	75 μμf disc, NPO
21-9	2 ✓	100 μμf disc, N750
⑥ 21-22	1 ✓	220 μμf disc
20-34	1 ✓	350 μμf mica (.00035)
⑦ 20-35	1 ✓	910 μμf mica (.00091)
20-57	1 ✓	2000 μμf mica (.002)
21-27	2 ✓	.005 μfd disc
21-16	7 ✓	.01 μfd disc
21-31	2 ✓	.02 μfd disc
25-120	1 ✓	60-40-40-20 μfd at 150, 150, 150, and 25 V, electrolytic
⑧ 31-8	3 ✓	1-10 μμf plastic trimmer
26-66	1 ✓	5.9 μμf variable
⑨ 26-64	1 ✓	21 μμf variable
26-81	1 ✓	2-gang variable

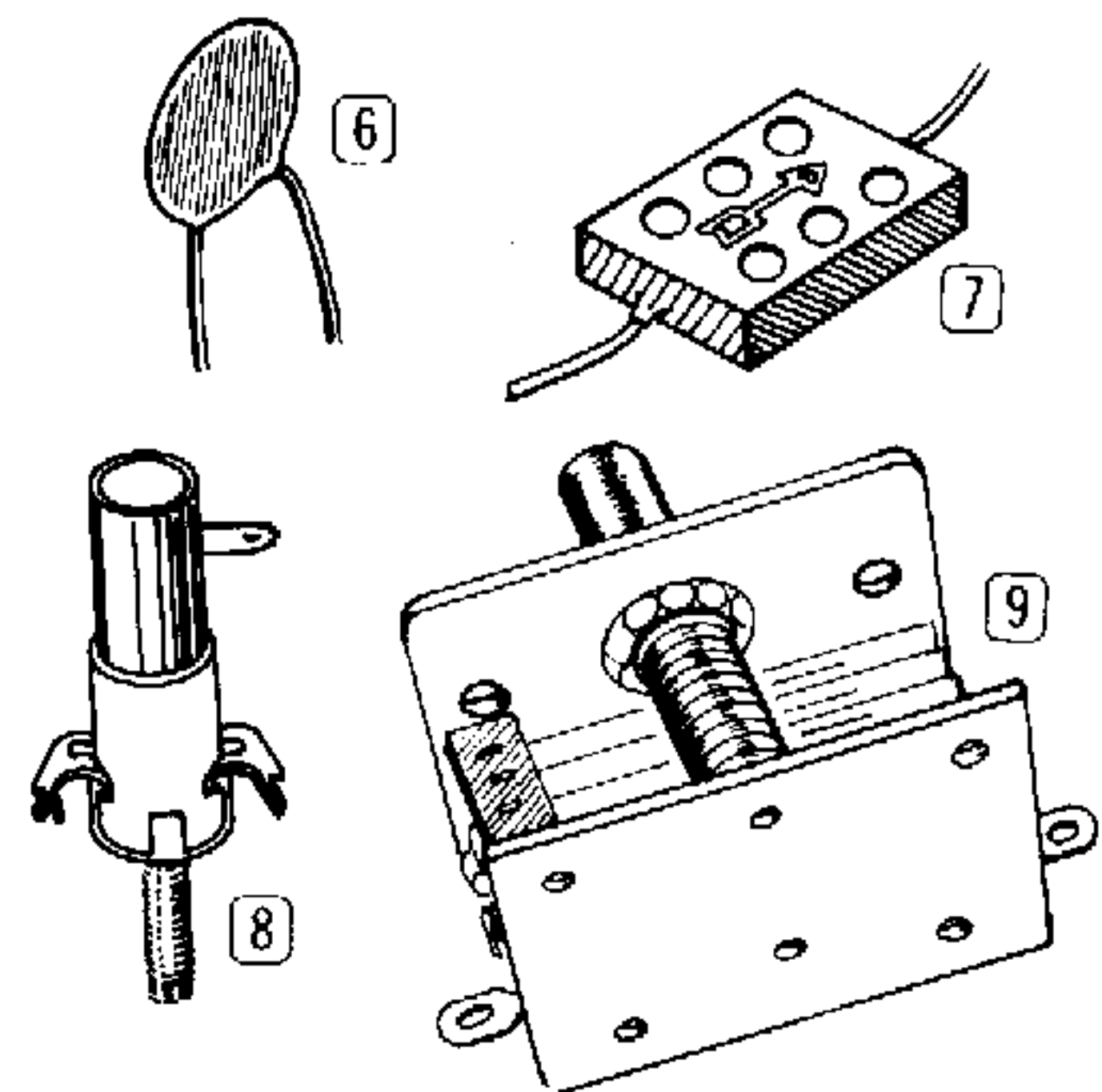
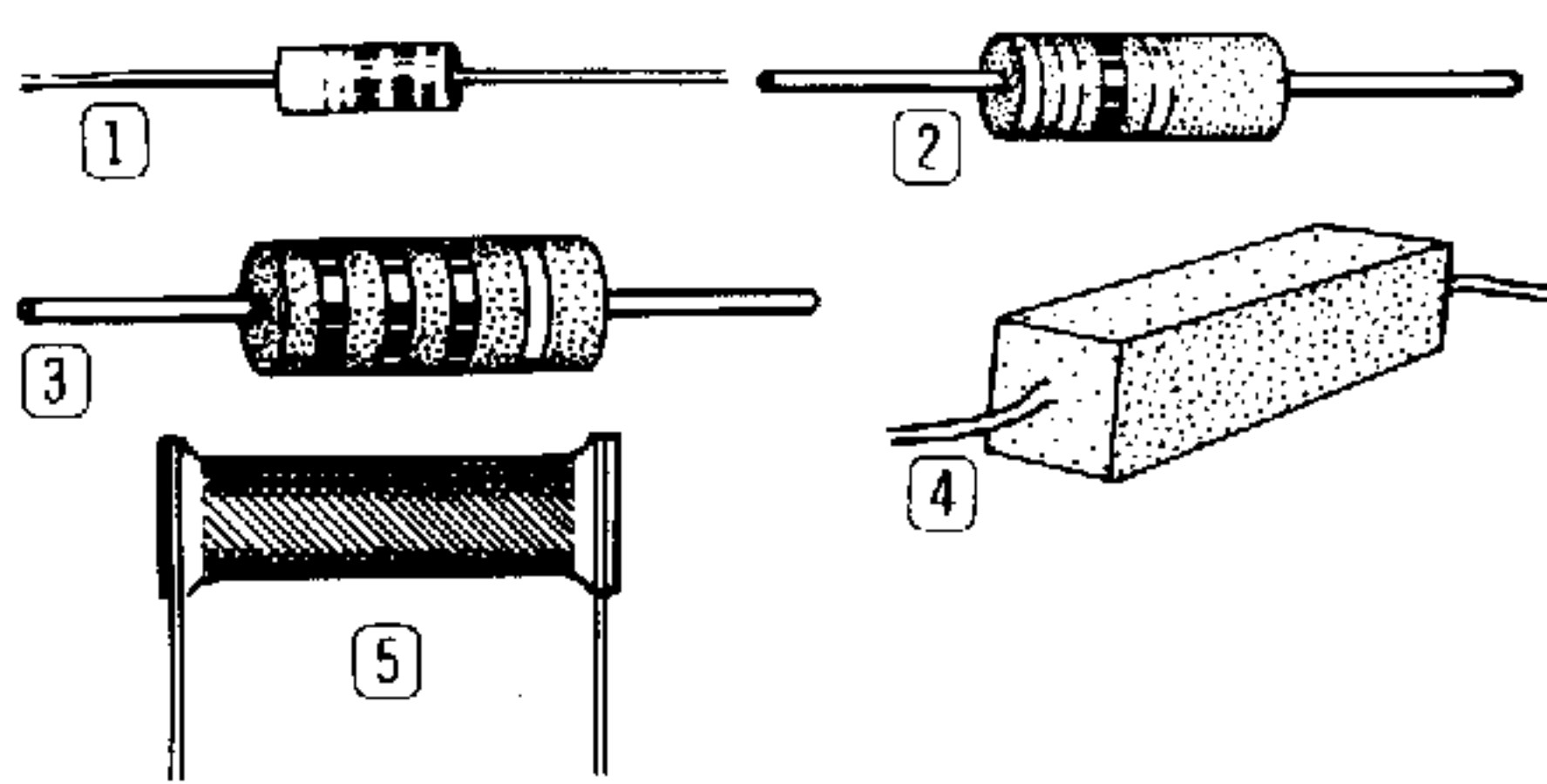

<b>Controls-Switches</b>		
⑩ 10-75	1 ✓	500 Ω control, tab mounting
⑪ 19-70	1 ✓	2.5 KΩ control with SPST switch normally closed

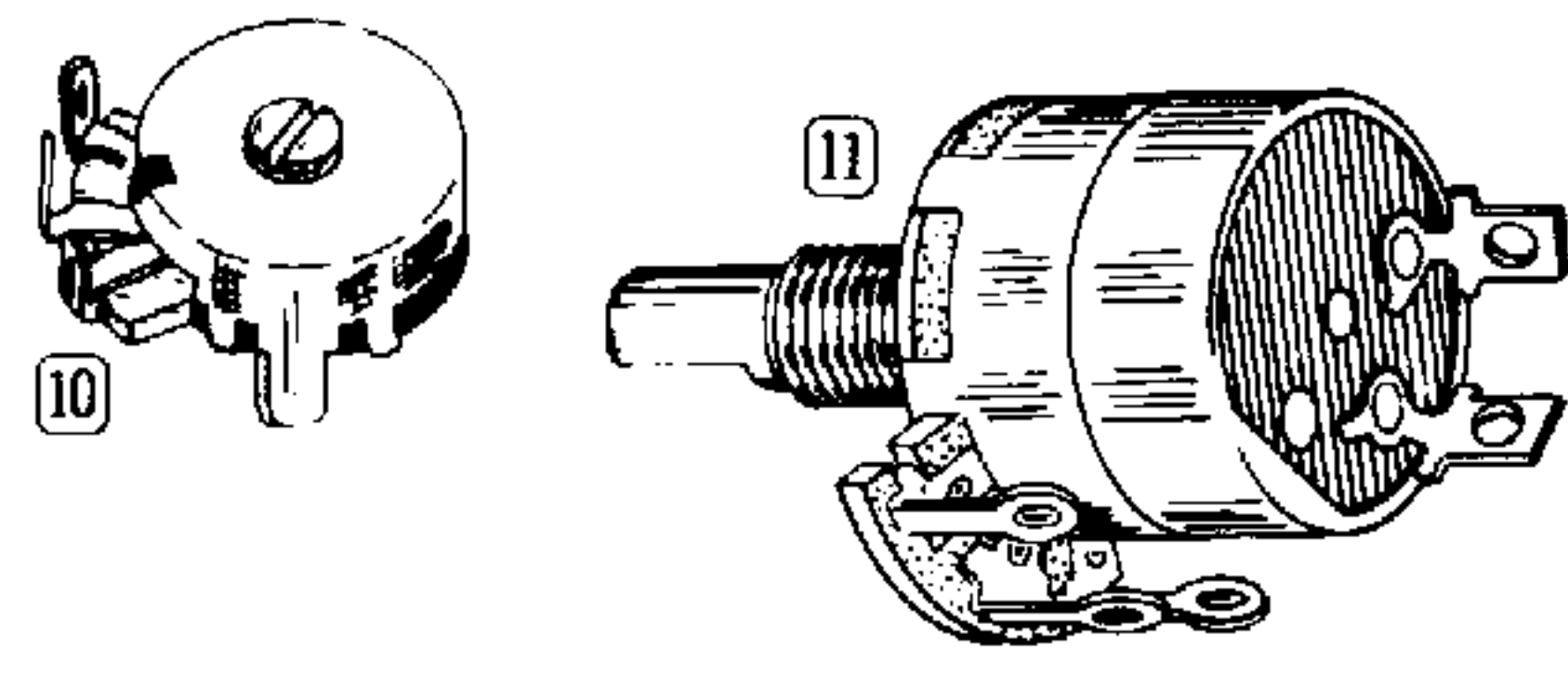



PART No.	PARTS Per Kit	DESCRIPTION
----------	---------------	-------------

Controls-Switches (cont'd.)

19-26	1 ✓	1 megohm control with SPST switch
① 60-1	1 ✓	SPST slide switch
63-53	1 ✓	3-position rotary switch
63-286	1 ✓	4-position, 2-section rotary switch

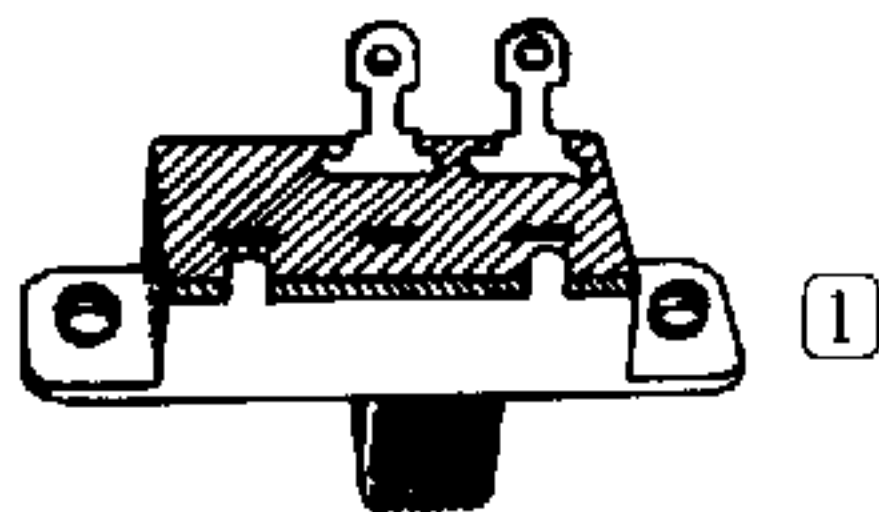

Packaged coil set (#141-25)  
Consisting of:

② 40-393	1 ✓	Band A antenna coil
40-397	1 ✓	Band A oscillator coil
40-394	1 ✓	Band B antenna coil
40-398	1 ✓	Band B oscillator coil
40-395	1 ✓	Band C antenna coil
40-399	1 ✓	Band C oscillator coil
40-396	1 ✓	Band D antenna coil
40-400	1 ✓	Band D oscillator coil

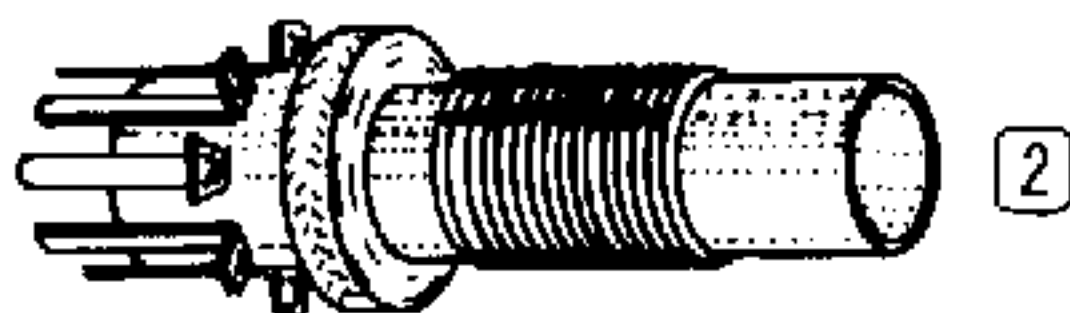

Chokes-Transformers

③ 45-27	1 ✓	30 μh RF choke
51-83	1 ✓	Output transformer
④ 52-47	2 ✓	455 kc IF transformer
54-121	1 ✓	Power transformer

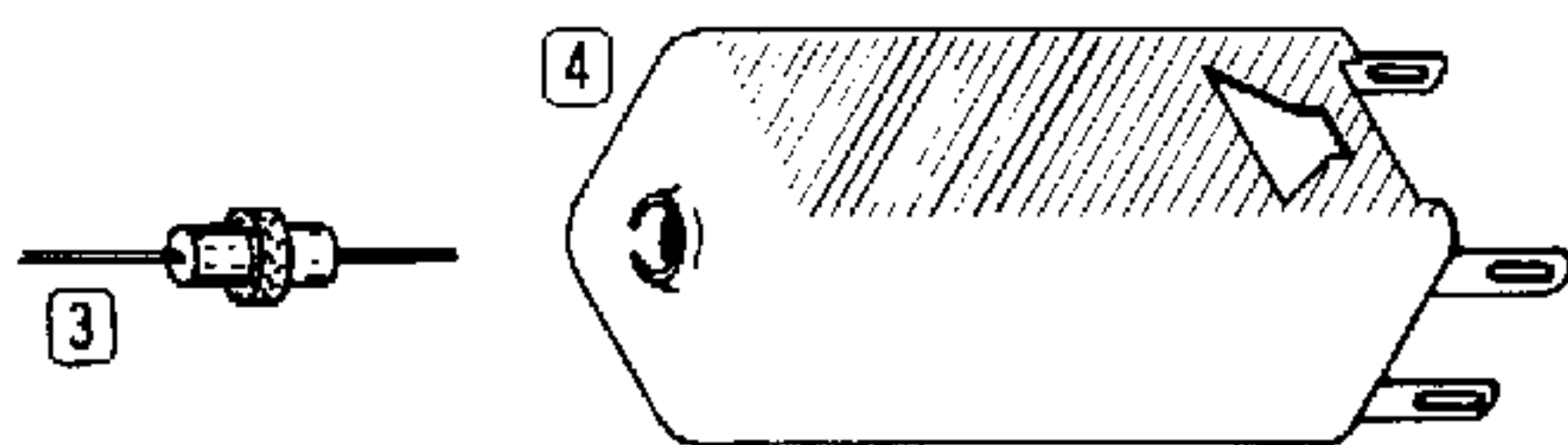

Diode-Tubes-Lamps

⑤ 57-27	1 ✓	Silicon diode, 500 ma
411-50	1 ✓	12BE6 tube
411-51	1 ✓	12BA6 tube
411-52	1 ✓	12AV6 tube
411-155	1 ✓	50C5 tube
412-1	2 ✓	#47 lamp



PART No.	PARTS Per Kit	DESCRIPTION
----------	---------------	-------------

Terminal Strips-Sockets

⑥ 431-8	1 ✓	3-screw terminal strip
⑦ 431-38	1 ✓	3-lug terminal strip
431-5	1 ✓	4-lug terminal strip
431-11	1 ✓	5-lug terminal strip
434-42	1 ✓	Phono socket
434-80	2 ✓	7-pin tube socket with shield clip
434-112	2 ✓	7-pin tube socket without shield clip
434-98	2 ✓	Pilot lamp socket with leads
436-4	1 ✓	Phone jack

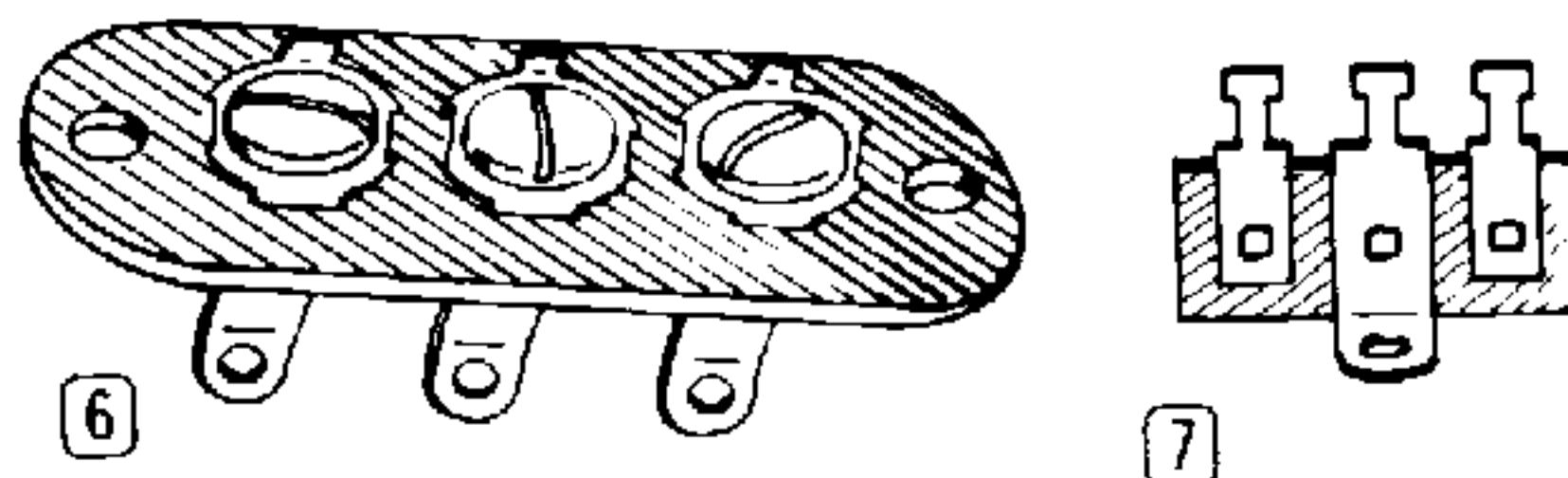

Insulators-Wire

73-1	1 ✓	3/8" rubber grommet
73-4	5 ✓	5/16" rubber grommet
89-1	1 ✓	Line cord
340-2	1 ✓	Length #20 bare wire
344-1	2 ✓	Lengths #22 hookup wire (1 black, 1 white)
347-2	1 ✓	Length 300 Ω twin lead

Hardware

204-9	2	Angle bracket
⑧ 250-8	10	#6 x 3/8" sheet metal screw
⑨ 250-89	49	6-32 x 3/8" screw
⑩ 250-116	4	6-32 x 1/4" screw (black)
⑪ 250-56	3	6-32 x 1/4" screw



⑫ 250-7	2	6-32 x 3/16" screw
⑬ 250-16	2	8-32 setscrew
⑭ 250-100	2	6-32 setscrew



⑮ 252-3	40	6-32 nut
⑯ 252-7	6	Control nut
⑰ 252-22	4	#6 speednut



253-10	1	Control flat washer
253-11	1	E ring

**PART No.**    **PARTS Per Kit**    **DESCRIPTION**

Hardware (cont'd.)

	253-45	6 ✓	1/2" flat washer
①	254-5	5 ✓	Control lockwasher
②	254-1	45 ✓	#6 lockwasher
	255-2	3 ✓	3/16" spacer
	258-1	1 ✓	Dial cord spring
	259-1	5 ✓	#6 solder lug
③	259-10	1 ✓	Control solder lug
	453-111	1 ✓	Shaft
	454-12	1 ✓	Flywheel
	455-13	1 ✓	Brass bushing



Speaker-Meter-Knobs

	401-40	1 ✓	3" x 5" speaker, 8 Ω
	407-77	1 ✓	Meter, 0-1 ma
	462-140	2 ✓	Large knob
	462-159	5 ✓	Small knob

Metal Parts

	90-M201F	1 ✓	Cabinet cover
	100-M353-F612	1 ✓	Dial back plate
	200-M325-F615	1 ✓	Chassis
④	204-M442	1 ✓	Switch mounting bracket
	204-M443	1 ✓	Capacitor mounting bracket
	205-M332	1 ✓	Bottom plate
	205-M333-F611	1 ✓	Front panel

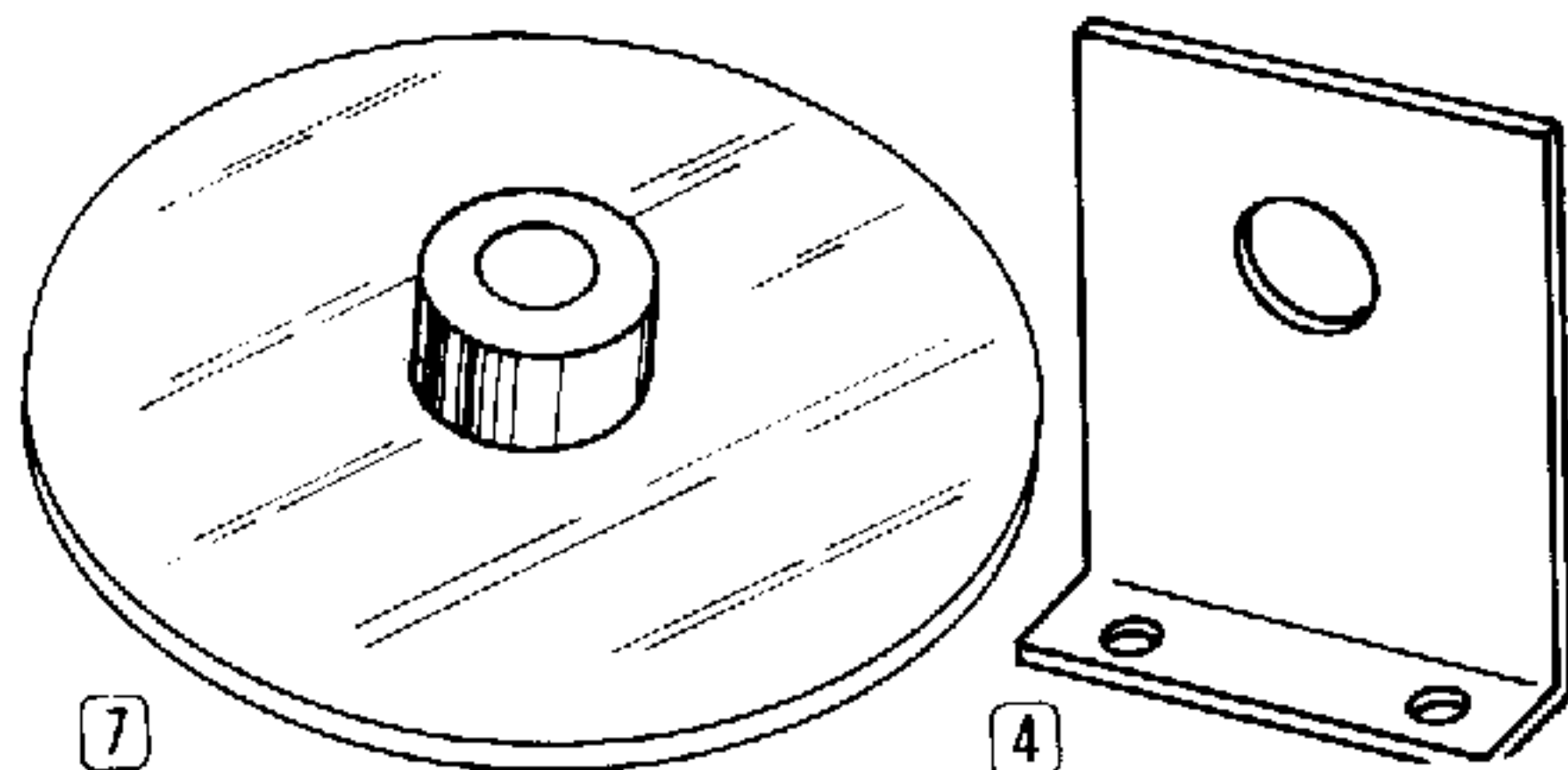

**PART No.**    **PARTS Per Kit**    **DESCRIPTION**

Miscellaneous

⑤	75-24	1 ✓	Line cord strain relief
	85-38	1 ✓	Circuit board
	94-382	1 ✓	Rear cover
⑥	100-M70	1 ✓	Dial drum
⑦	100-M351	1 ✓	Band spread dial
	100-M352	1 ✓	Dial cord
	206-77	2 ✓	Tube shield
	207-4	1 ✓	Plastic clamp
⑧	260-27	2 ✓	Meter clip
	261-16	2 ✓	Plastic feet
	261-17	2 ✓	Tapered plastic feet
	463-30	1 ✓	Dial pointer
	464-20F614-655	1 ✓	Dial window
	490-1	1 ✓	Alignment tool
	331-6		Solder
	595-492	1 ✓	Manual

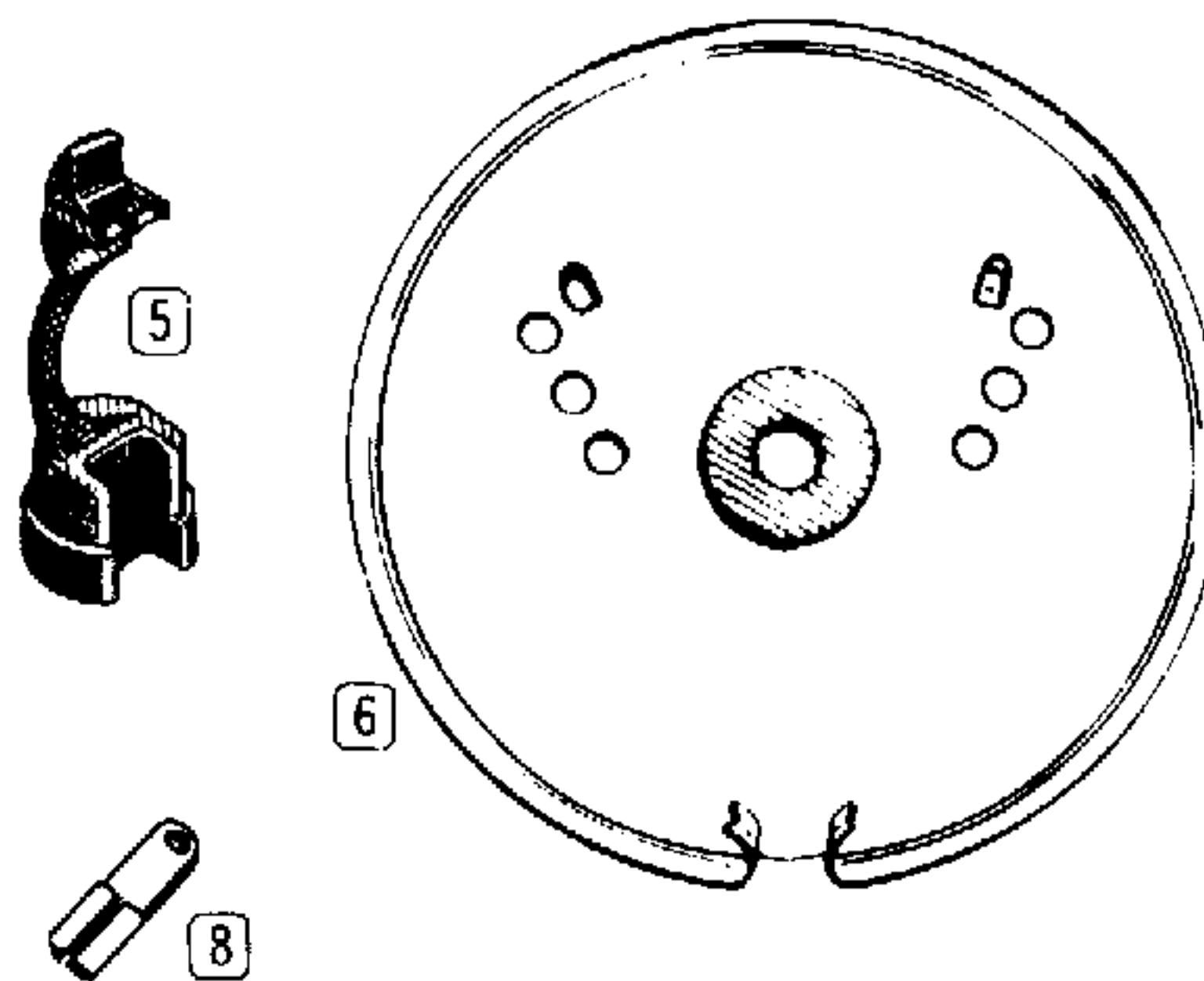

## PROPER SOLDERING TECHNIQUES

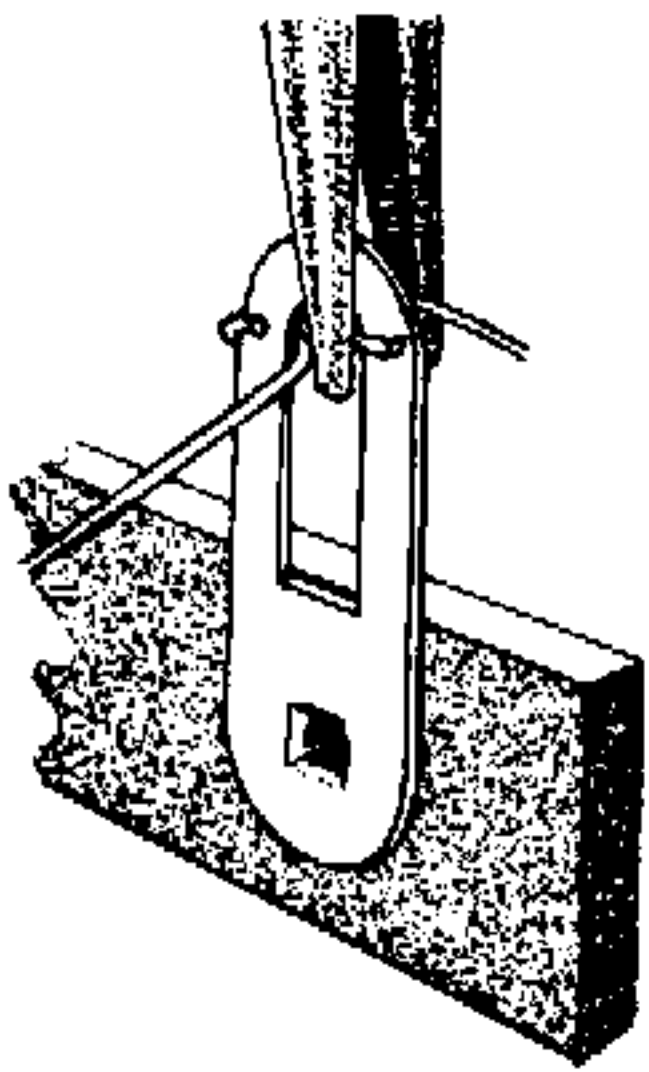

CRIMP WIRES

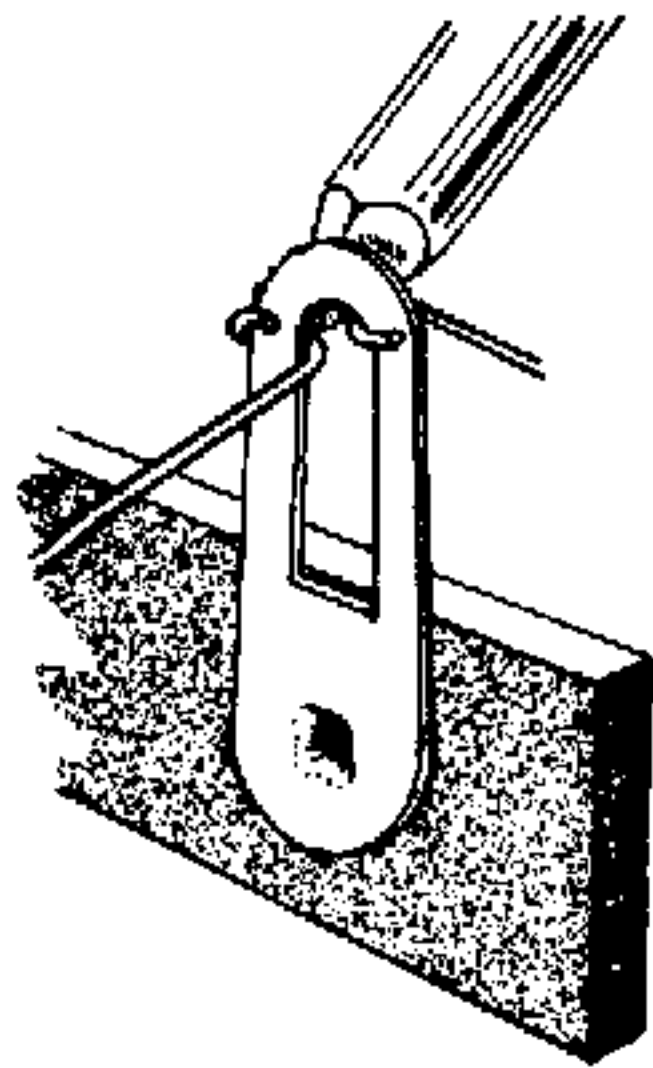

HEAT CONNECTION

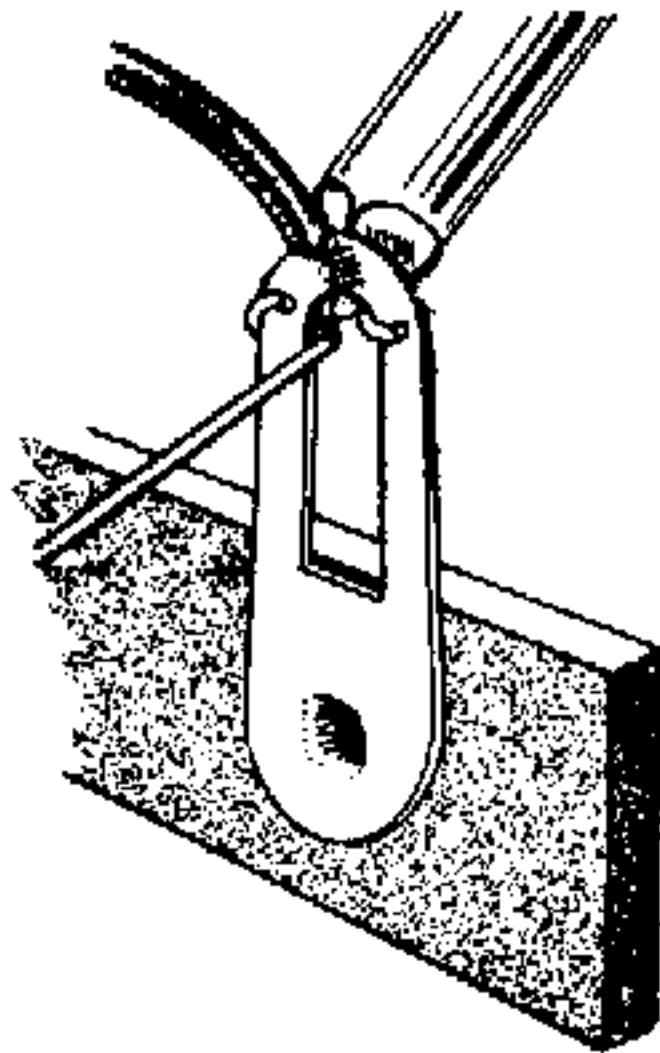

APPLY SOLDER

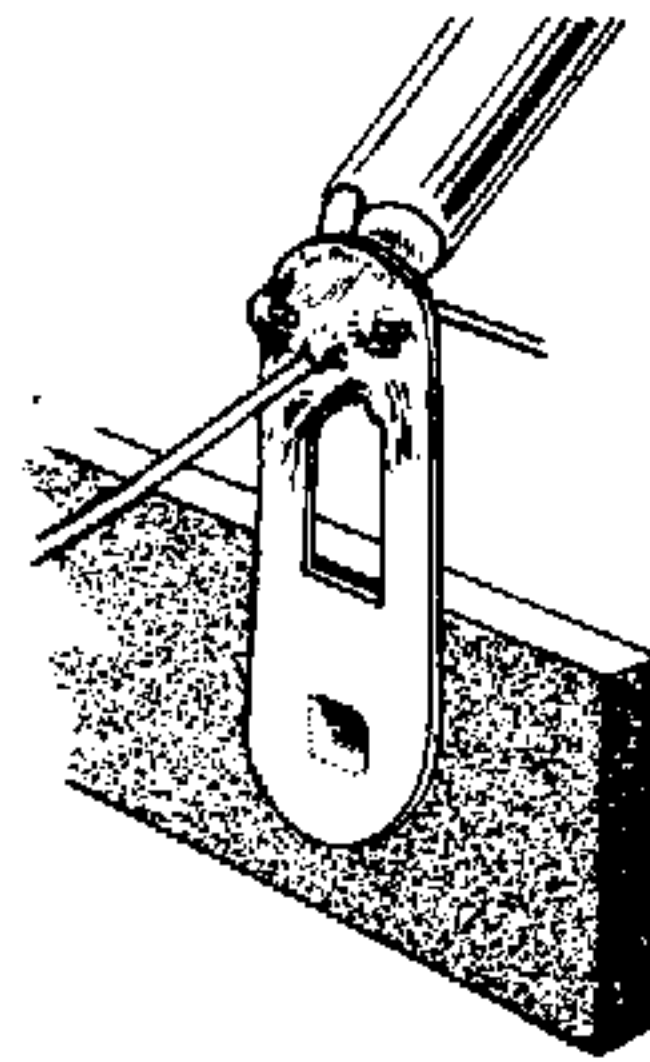
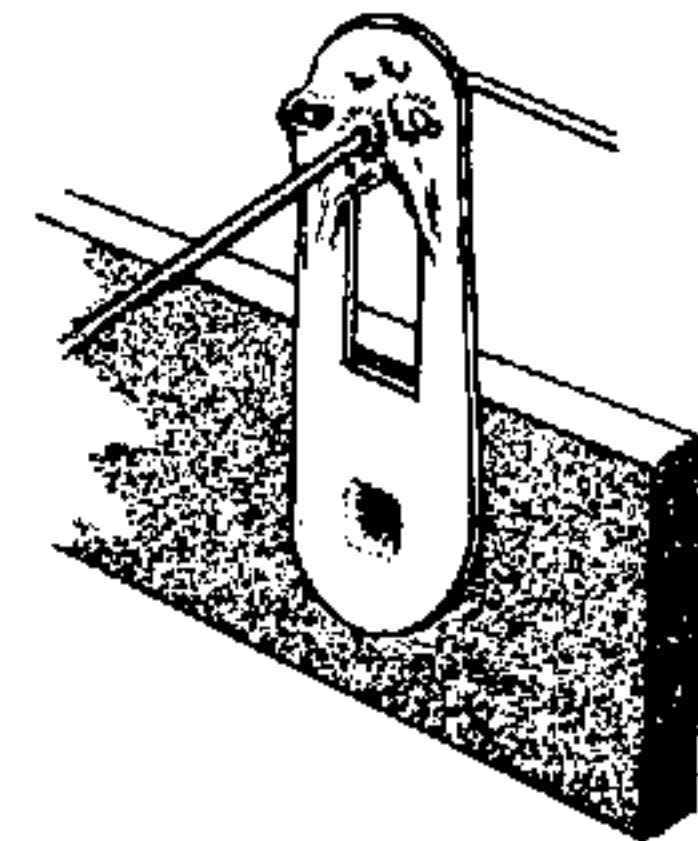
ALLOW SOLDER  
TO FLOWPROPER SOLDER  
CONNECTION

Only a small percentage of HEATHKIT equipment purchasers find it necessary to return an instrument for factory service. Of these instruments, by far the largest portion of malfunctions are due to poor or improper soldering.

If terminals are bright and clean and free of wax, frayed insulation and other foreign substances, no difficulty will be experienced in soldering. Correctly soldered connections are essential if the performance engineered into a kit is to be fully realized. If you are a beginner with no experience in soldering, a half hour's practice with some odd lengths of wire may be a worthwhile investment.

For most wiring, a 30 to 100 watt iron or its equivalent in a soldering gun is very satisfactory. A lower wattage iron than this may not heat the connection enough to flow the solder smoothly over the joint. Keep the iron tip clean and bright by wiping it from time to time with a cloth.

### CHASSIS WIRING AND SOLDERING

1. Unless otherwise indicated, all wire used is the type with colored insulation (hookup wire); the size of the conductor is the same for all colors of hookup wires furnished with this kit. In preparing a length of hookup wire, 1/4" of insulation should be removed from each end unless directed otherwise in the construction step.
2. To avoid breaking internal connections when stripping insulation from the leads of transformers or similar components, care should be taken not to pull directly on the lead. Instead, hold the lead with pliers while it is being stripped.
3. Leads on resistors, capacitors and similar components are generally much longer than they need to be to make the required connections. In these cases, the leads should be cut to proper length before the part is added to the chassis. In general, the leads should be just long enough to reach their terminating points.
4. Crimp or bend the lead (or leads) around the terminal to form a good joint without relying on solder for physical strength. If the wire is too large to allow bending or if the step states that the wire is not to be crimped, position the wire so that a good solder connection can still be made.
5. Position the work, if possible, so that gravity will help to keep the solder where you want it.
6. Place a flat side of the soldering iron tip against the joint to be soldered until it is heated sufficiently to melt the solder.
7. Then place the solder against the heated terminal and it will immediately flow over the joint; use only enough solder to thoroughly wet the junction. It is usually not necessary to fill the entire hole in the terminal with solder.
8. Remove the solder and then the iron from the completed junction. Use care not to move the leads until the solder is solidified.

A poor or cold solder joint will usually look crystalline and have a grainy texture, or the solder will stand up in a blob and will not have adhered to the joint. Such joints should be re-

heated until the solder flows smoothly over the entire junction. In some cases, it may be necessary to add a little more solder to achieve a smooth bright appearance.

ROSIN CORE SOLDER HAS BEEN SUPPLIED WITH THIS KIT. THIS TYPE OF SOLDER MUST BE USED FOR ALL SOLDERING IN THIS KIT. ALL GUARANTEES ARE VOIDED AND WE WILL NOT REPAIR OR SERVICE EQUIPMENT IN WHICH ACID CORE SOLDER OR PASTE FLUXES HAVE BEEN USED. IF ADDITIONAL SOLDER IS NEEDED, BE SURE TO PURCHASE ROSIN CORE (60:40 or 50:50 TIN-LEAD CONTENT) RADIO TYPE SOLDER.

## CIRCUIT BOARD WIRING AND SOLDERING

Before attempting any work on the circuit boards, read the following instructions carefully and study the Figures. It is only necessary to observe the following basic precautions to insure proper operation of the unit the first time it is turned on.

Proper mounting of components on the board is essential for good performance. A good general rule to follow is that all components on the board should be mounted tightly to the board, unless instructions state otherwise. All leads should be kept as short as possible to minimize the effects of stray capacity in the wiring. Proper and improper methods of mounting are illustrated in the accompanying Figures.

**NOTE:** Exercise care not to damage resistors or capacitors when bending the leads as shown.

Tubular capacitors and resistors will fit properly if the leads are bent as shown. Disc capacitors will generally fit in place with no lead preparation other than determining that the leads are straight. Components with lugs normally require no preparation unless the lugs appear to be bent, in which case they can be straightened with pliers.

Parts should be inserted as instructed, and the leads bent outward slightly, as illustrated, to lock them in place.

Components will be soldered in groups; after a group of components have been installed, instructions will be given to solder them. When the components have been soldered, diagonal cutters may be used to cut off the excess leads close to the board.

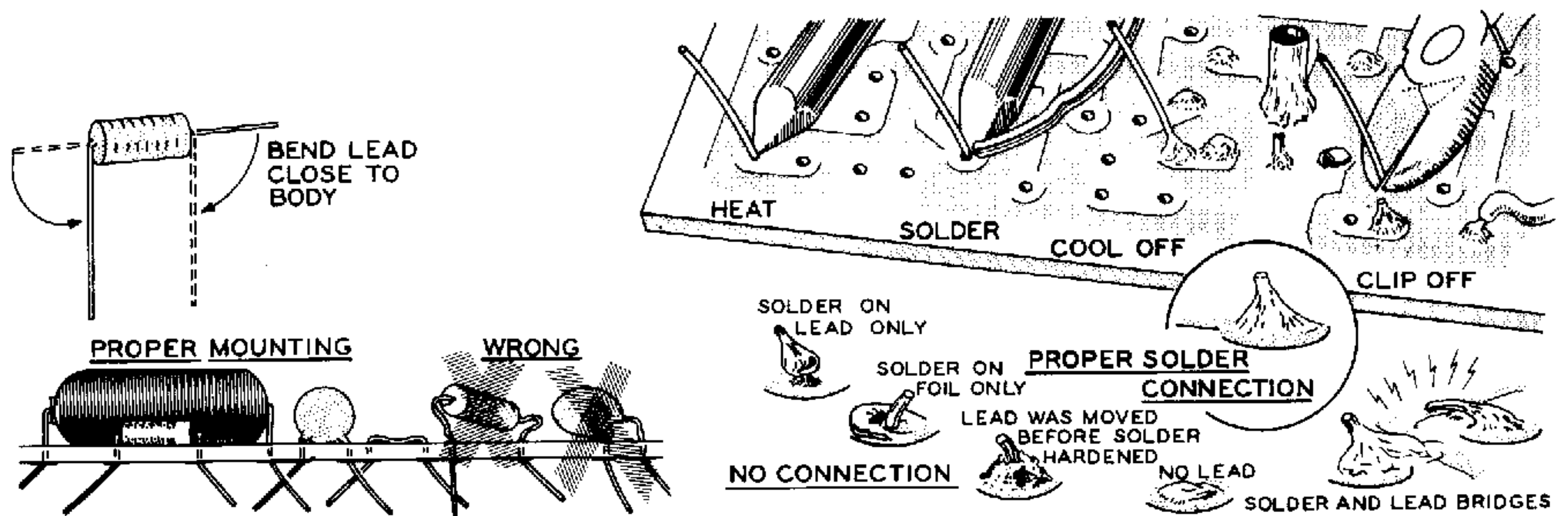

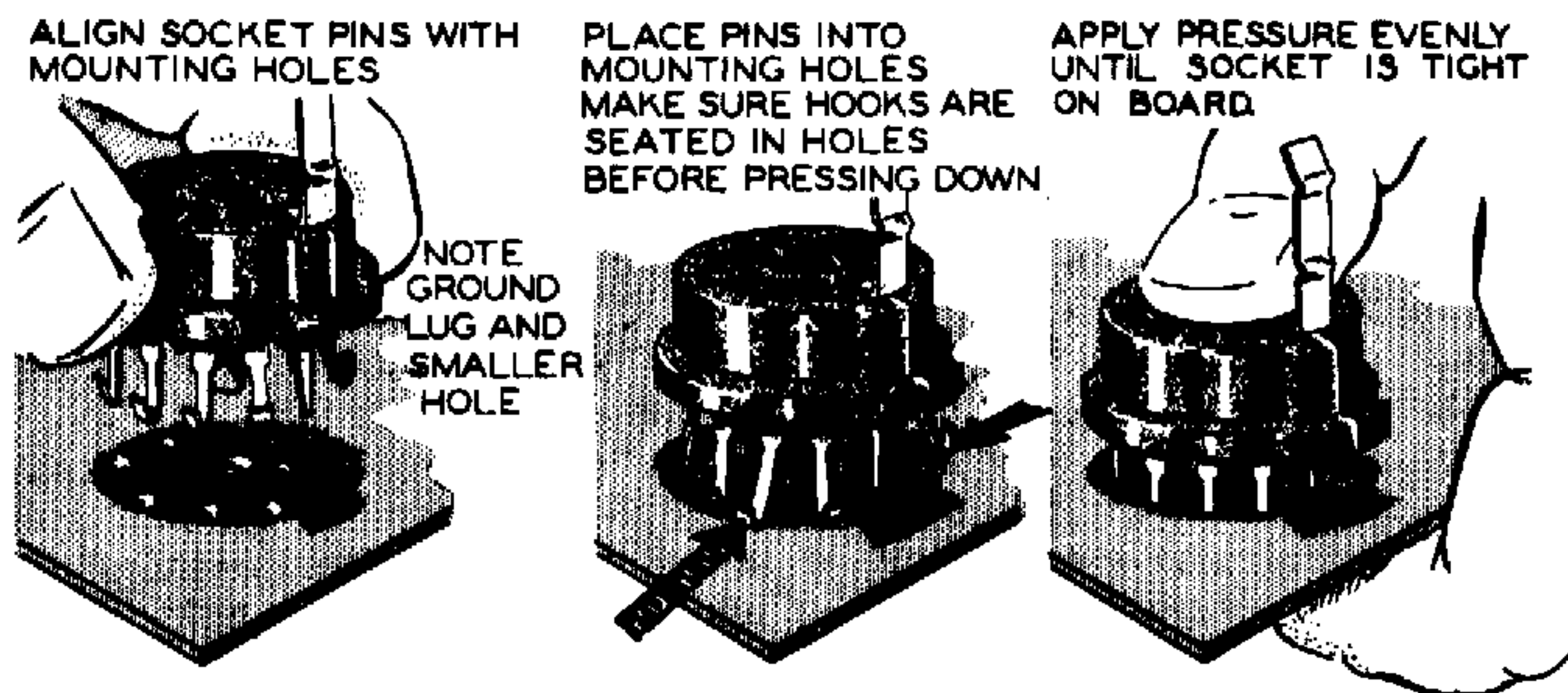

The actual technique of soldering leads to a circuit board is quite simple. Position the tip of the soldering iron so that it firmly contacts both the circuit board foil and the wire or lug to be soldered, as shown. The iron should be held so that solder is not likely to flow to adjacent foil conductors or connections. The solder should immediately be placed between the iron and the joint to be soldered. Remove the length of solder as soon as its end begins to melt and flow onto the lead and foil. Hold the tip of the iron in place only until the solder begins to flow outward over the foil; then remove the iron quickly.

Avoid overheating the connection. A soldering pencil or small iron (approximately 30 watts) is ideal for use in circuit board work. If only a high wattage iron or soldering gun is available, precautions must be taken to avoid circuit board damage due to overheating and excess solder.

The use of excessive amounts of solder will

increase the possibility of bridging between foil conductors or plugging holes which are to be left open for wires which may be added later on. If solder is accidentally bridged across insulating areas between conductors, it can be cleaned off by heating the connection carefully and quickly wiping or brushing the solder away with a soft cloth or clean brush. Holes which become plugged can be cleared by heating the area immediately over the hole while gently pushing the lead of a resistor through the hole from the opposite side, and withdrawing the lead before the solder rehardens. Do not force the lead through; too much pressure before the solder has time to soften may separate the foil from the board.

In cases where foil does become damaged, repairs can usually be made with little difficulty. A break in the foil can be rejoined with a small piece of bare wire soldered across the gap, or between the foil and the lead of a component. "Hairline" breaks can usually be repaired by bridging them with a small amount of solder.

## STEP-BY-STEP PROCEDURE

The following instructions are presented in a logical step-by-step sequence to enable you to complete your kit with the least possible confusion. Be sure to read each step all the way through before beginning the specified operation. Also read several steps ahead of the actual step being performed. This will familiarize you with the relationship of the subsequent operations. When the step is completed, check it off in the space provided. This is particularly important as it may prevent errors or omissions, especially if your work is interrupted. Some kit builders have also found it helpful to mark each lead in colored pencil on the Pictorial as it is added.

The fold-out diagrams in this manual may be removed and attached to the wall above your working area; but, because they are an integral part of the instructions, they should be returned to the manual after the kit is completed.

In general, the illustrations in this manual correspond to the actual configuration of the kit; however, in some instances the illustra-

tions may be slightly distorted to facilitate clearly showing all of the parts.

The abbreviation "NS" indicates that a connection should not be soldered yet as other wires will be added. When the last wire is installed, the terminal should be soldered and the abbreviation "S" is used to indicate this. Note that a number will appear after each solder instruction. This number indicates the number of leads that are supposed to be connected to the terminal in point before it is soldered. For example, if the instruction reads, "Connect a lead to lug 1 (S-2)," it will be understood that there will be two leads connected to the terminal at the time it is soldered. (In cases where a lead passes through a terminal or lug and then connects to another point, it will count as two leads, one entering and one leaving the terminal.)

The steps directing the installation of resistors include color codes to help identify the parts. Also, if a part is identified by a letter-number designation on the Schematic, its designation will appear at the beginning of the construction step which directs its installation.

## STEP-BY-STEP ASSEMBLY

### PARTS MOUNTING

Refer to Pictorial 1 (fold-out from Page 6) for the following steps.

- (✓) Position the chassis as shown.
- (✓) Locate the four speednuts and insert one in each cutout in the ends of the chassis, as shown. The flat side of each speednut should face outward.
- (✓) Install 5/16" rubber grommets at AA and CC.
- (✓) Install the 3/8" rubber grommet at BB.
- (✓) Referring to Figure 1, install a 3-lug terminal strip at N. Use a 6-32 x 3/8" screw, #6 lockwashers, and a 6-32 nut.

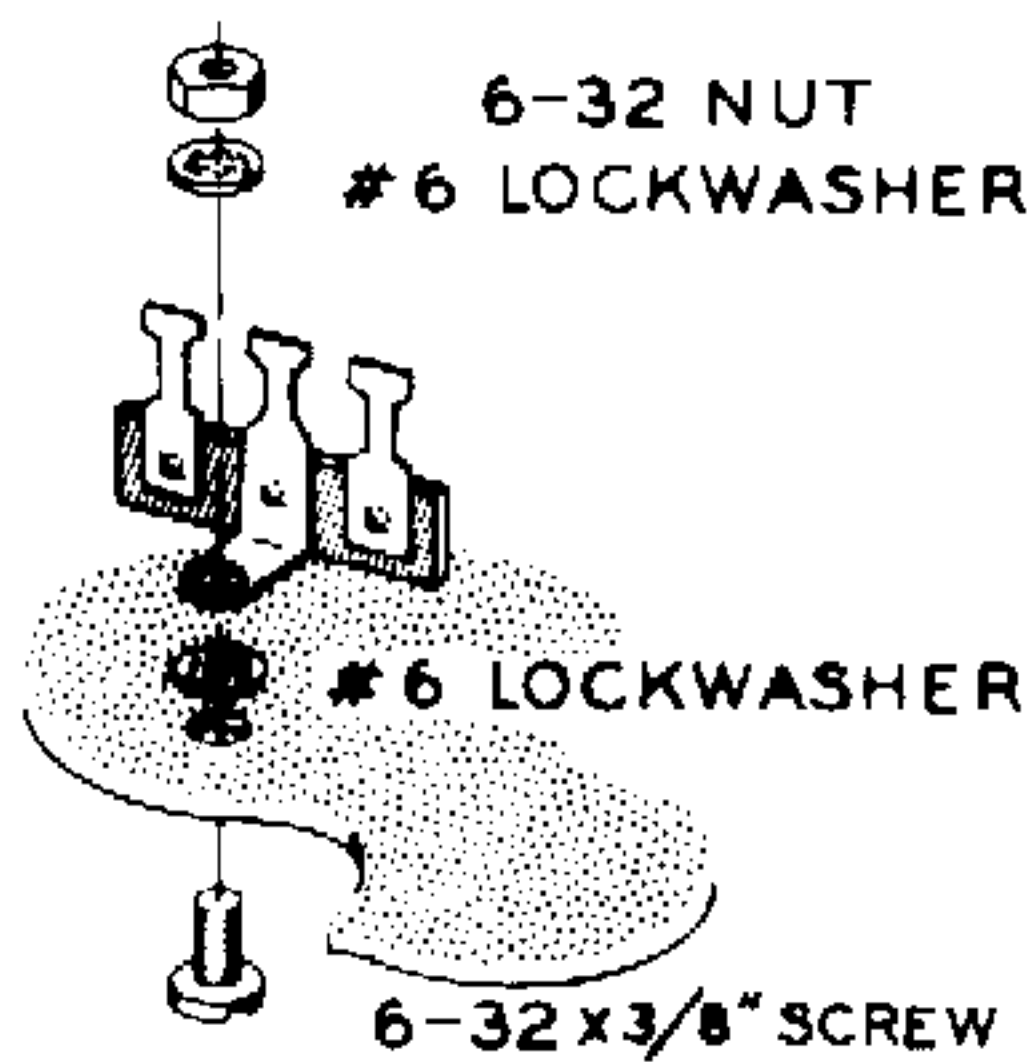

Figure 1

- (✓) R13. Install the tab mounting control (#10-75) at Q as shown in Figure 2.

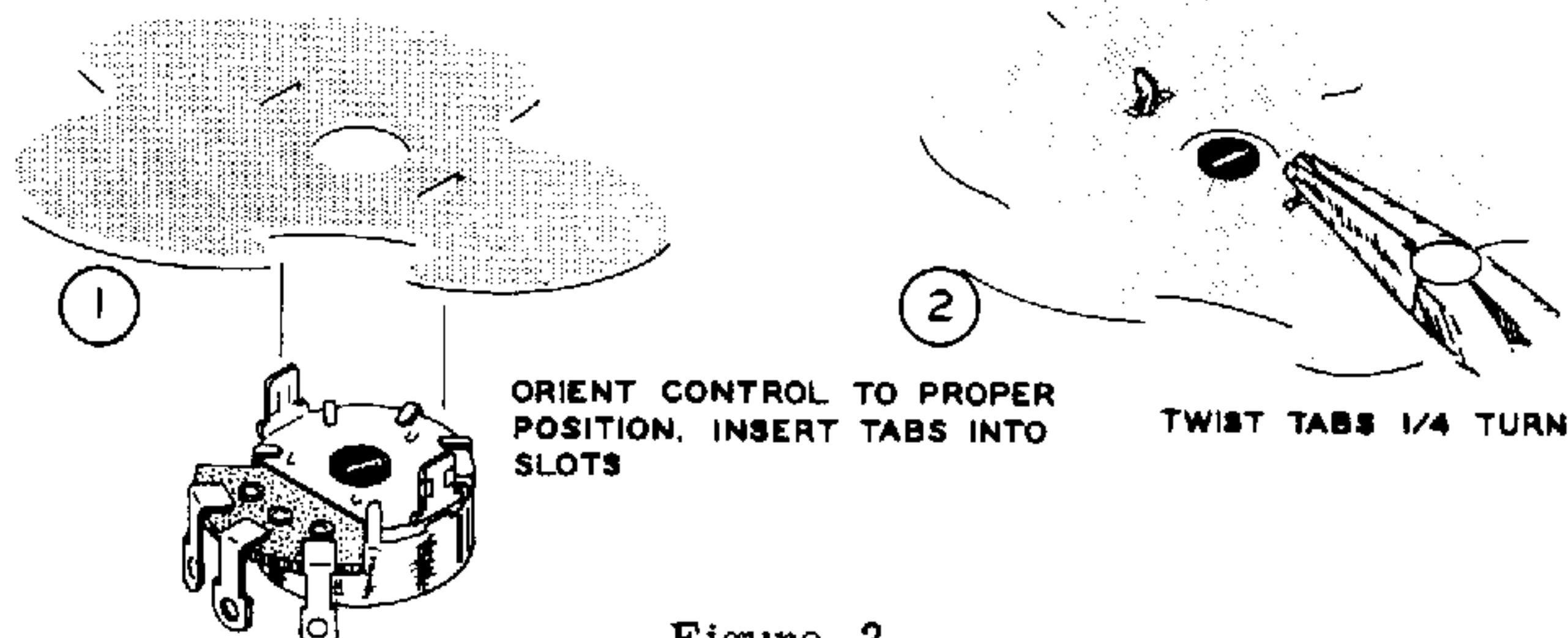

Figure 2

- (✓) Referring to Figure 3, install a 3-lug screw-type terminal strip and a #6 solder lug at W. Use 6-32 x 3/8" screws, #6 lockwashers, and 6-32 nuts. The solder lug goes on the mounting screw nearest hole U.

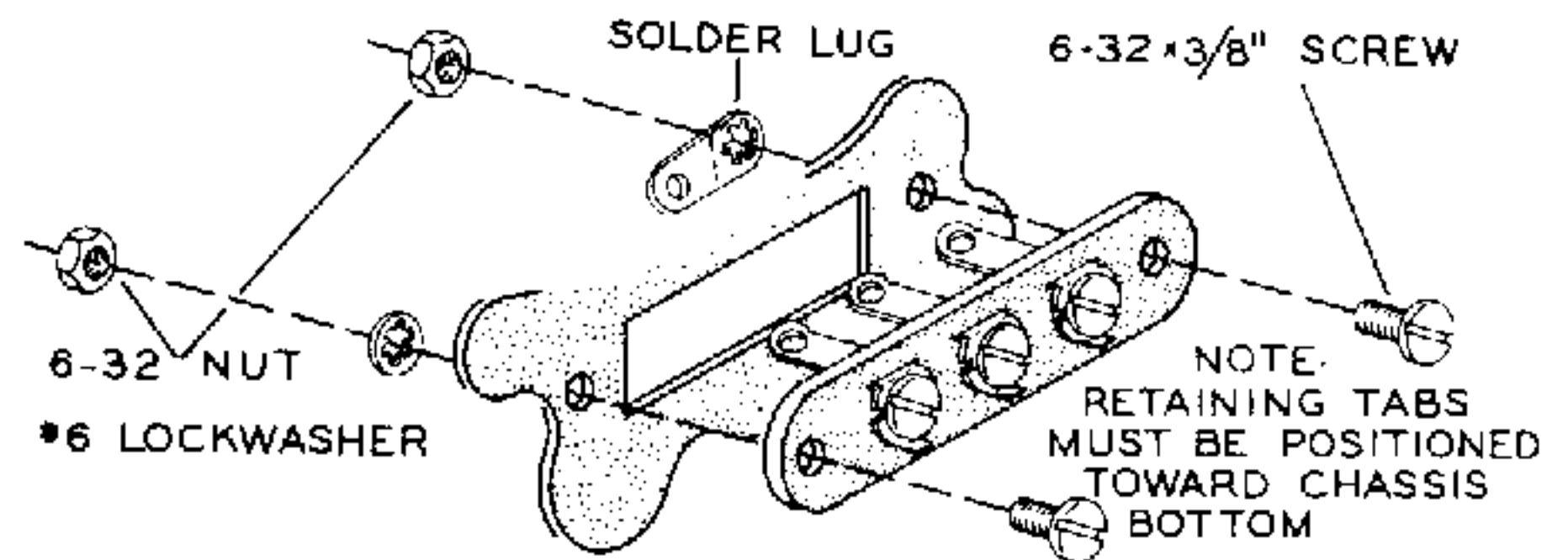

Figure 3

- (✓) Install the phono socket at X, using 6-32 x 3/8" screws, #6 lockwashers, and 6-32 nuts as shown in Figure 4.

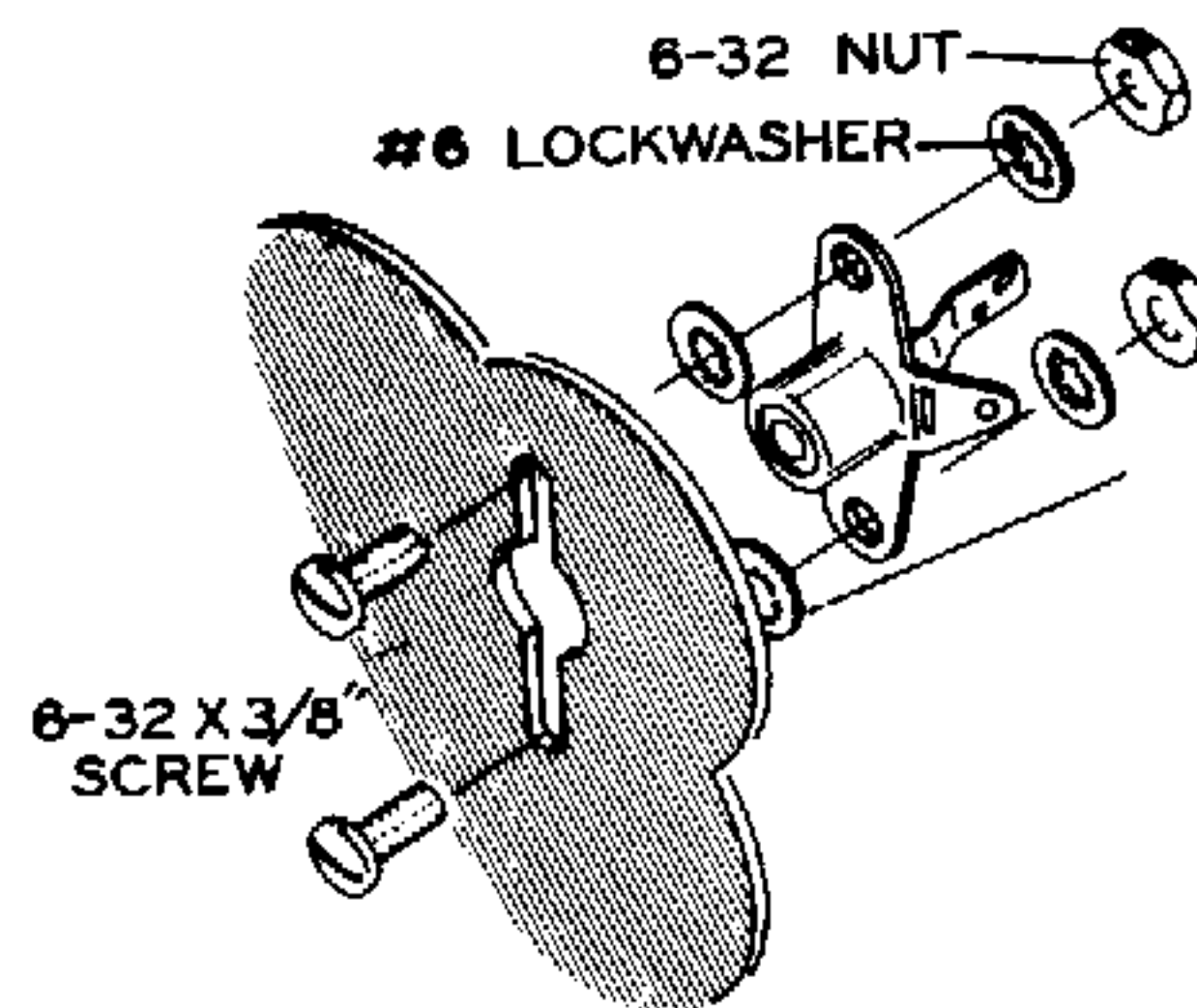

Figure 4

- (✓) Install the slide switch at Y, using two 6-32 x 3/8" screws. No lockwashers or nuts are used. Position the switch as shown in Pictorial 1.

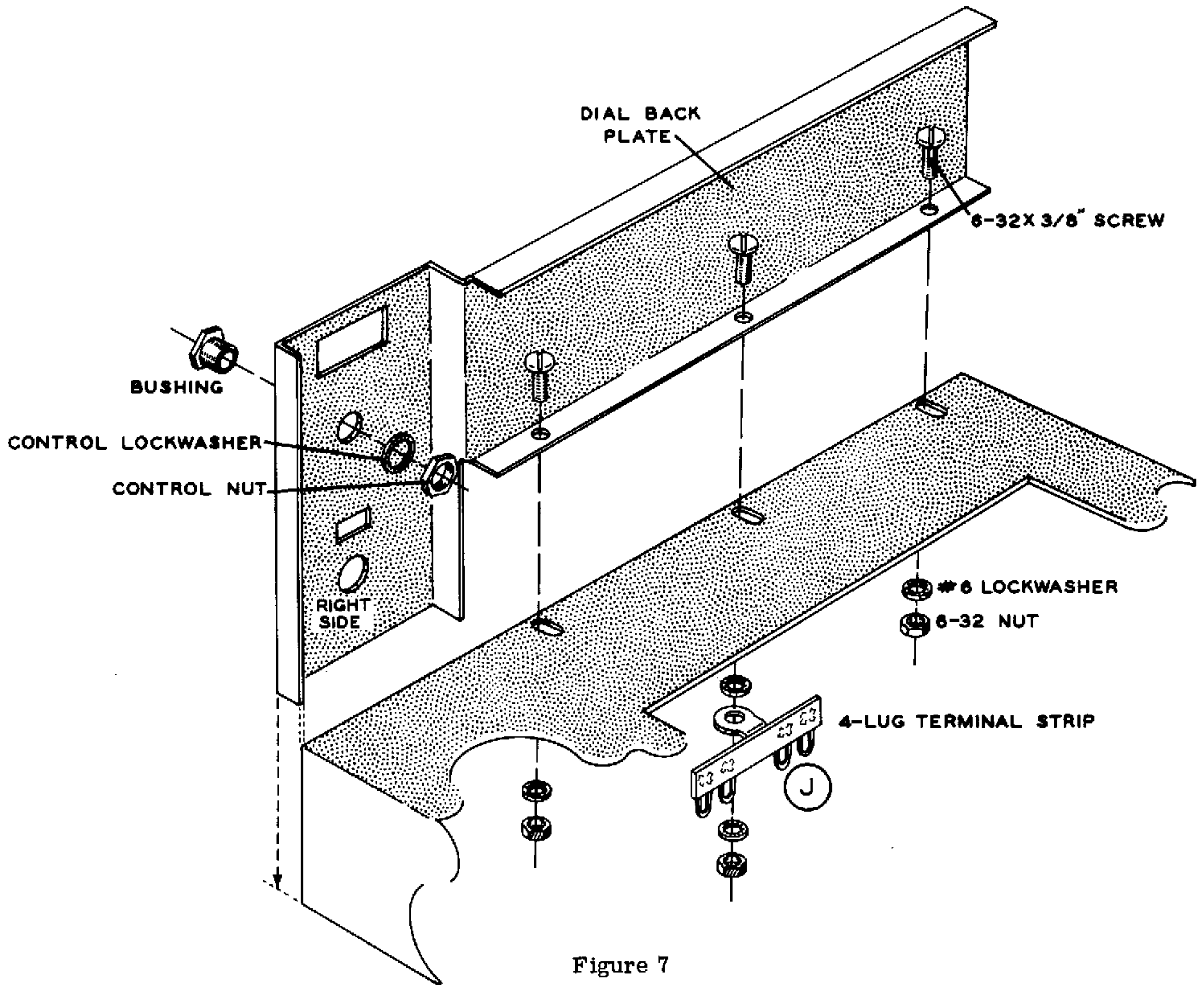

Figure 7

(✓) Referring to Figure 5, install the phone jack at Z, using a control lockwasher, flat washer, and nut. Position as shown.

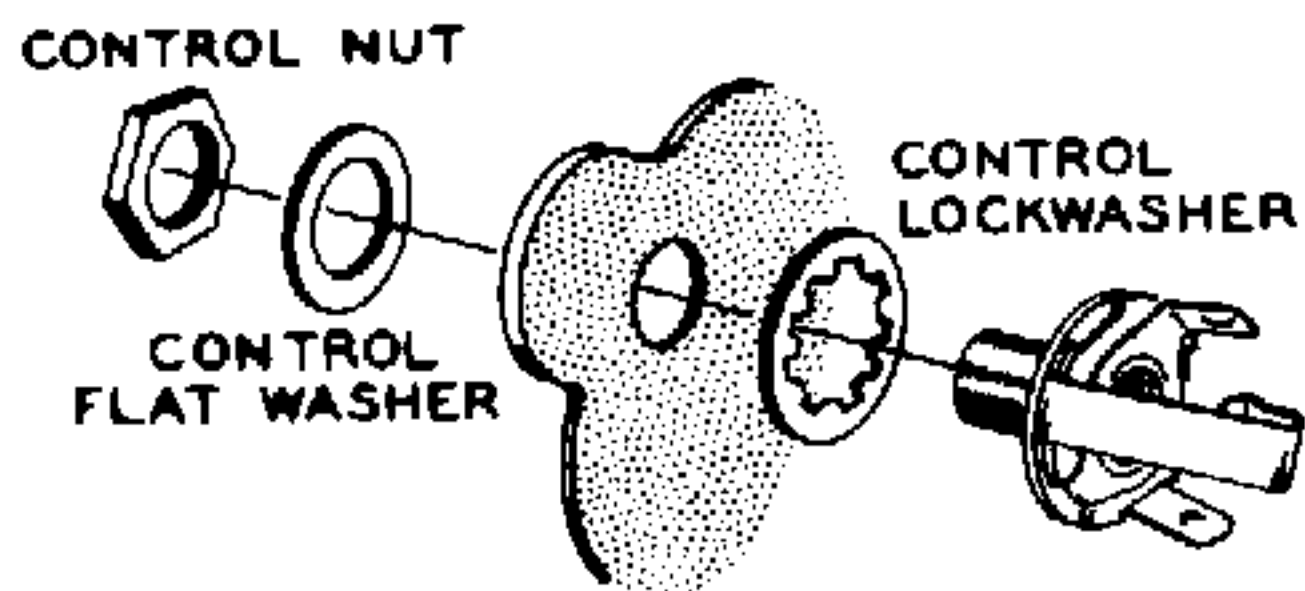

Figure 5

(✓) C9. Install a variable capacitor (#26-66) at M. Use three 6-32 x 3/8 inch screws and three 3/16 inch spacers. The spacers go between the

capacitor frame and the chassis, as shown in Figure 6.

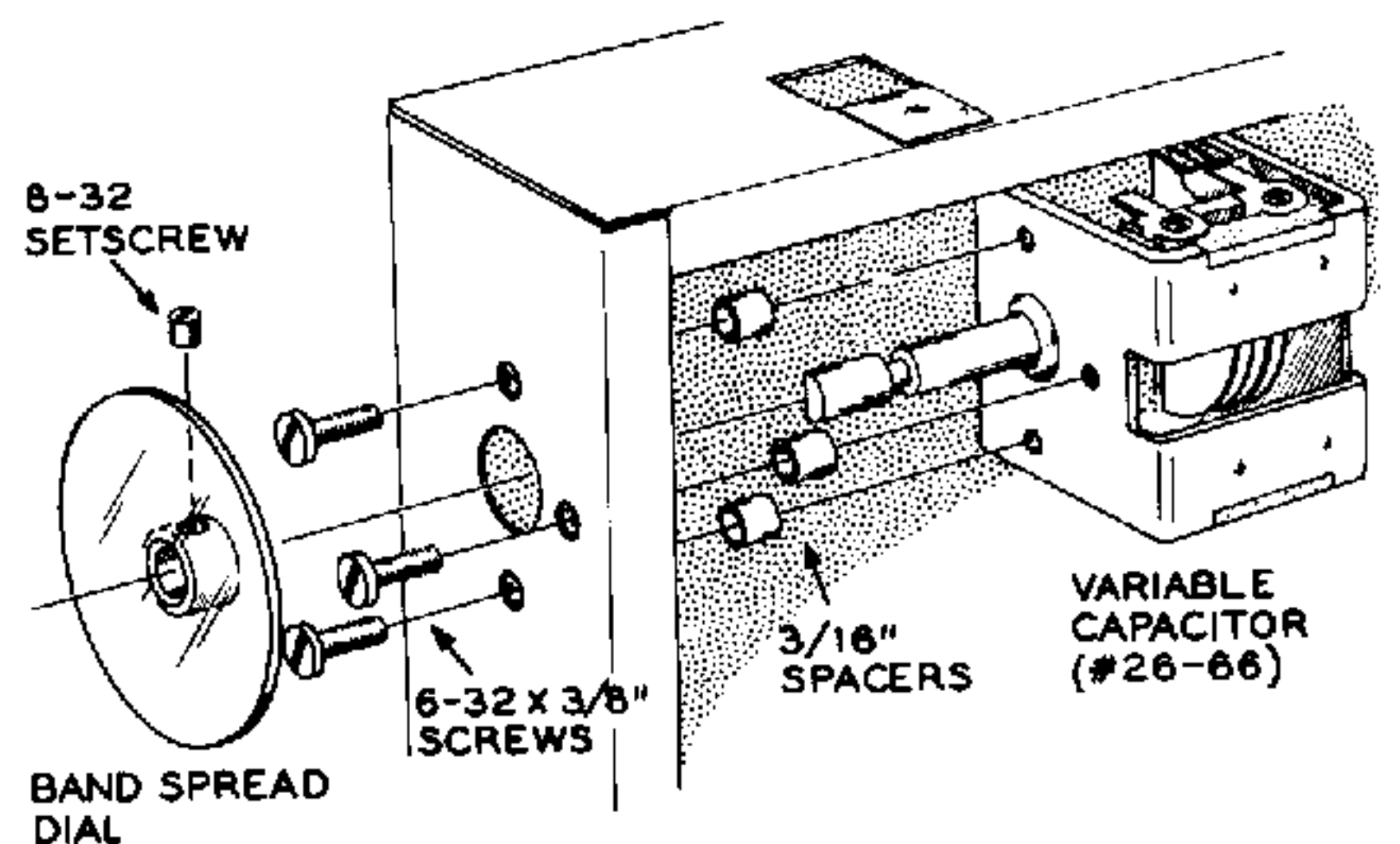

Figure 6



- (✓) Locate the round plastic dial (#100-M351) and install an 8-32 setscrew in the bushing. Now install the plastic dial on the capacitor shaft at M. The bushing should be toward the chassis. Do not tighten the setscrew yet.
- (✓) Referring to Figure 7, install the dial back plate on top of the chassis and a 4-lug terminal strip under the chassis at J as shown. Use three 6-32 x 3/8" screws, four #6 lockwashers, and three 6-32 nuts. Be sure the right-hand end of this plate sets flush against the front of the chassis.
- (✓) Install a brass bushing in the tophole in the dial back plate, using a control lockwasher and a control nut as shown.
- (✓) Make sure the plates of variable capacitor M are fully meshed. Position the round plastic dial on the capacitor shaft so that the #0 is centered in the rectangular cutout and tighten the setscrew. Make sure the plastic dial does not rub against the dial back plate.
- (✓) Install the 3-position rotary switch (#63-53) at S1 inside the chassis and the large

plastic dial plate on the outside of the chassis as shown in Figure 8. Use a control lockwasher and nut but do not mount the front panel or tighten the nut at this time.

- (✓) C12. Mount variable capacitor (#26-64) at K on the inside of the chassis and the large plastic dial plate on the outside of the chassis as shown in Figure 8. Use three 6-32 x 1/4" screws. Do not overtighten these screws as the plastic may crack.
- (✓) Remove the nut on switch S1 and install the front panel over the plastic dial plate on the front of the chassis. Replace the nut on switch S1 and tighten. Position this switch as shown in Pictorial 1.
- ( ) R9. Install a 2500  $\Omega$  control (#19-70) at H using a control lockwasher and nut as shown.
- (✓) R16. Similarly, install a 1 megohm control (#19-26) at F. Temporarily set the chassis aside for use later.

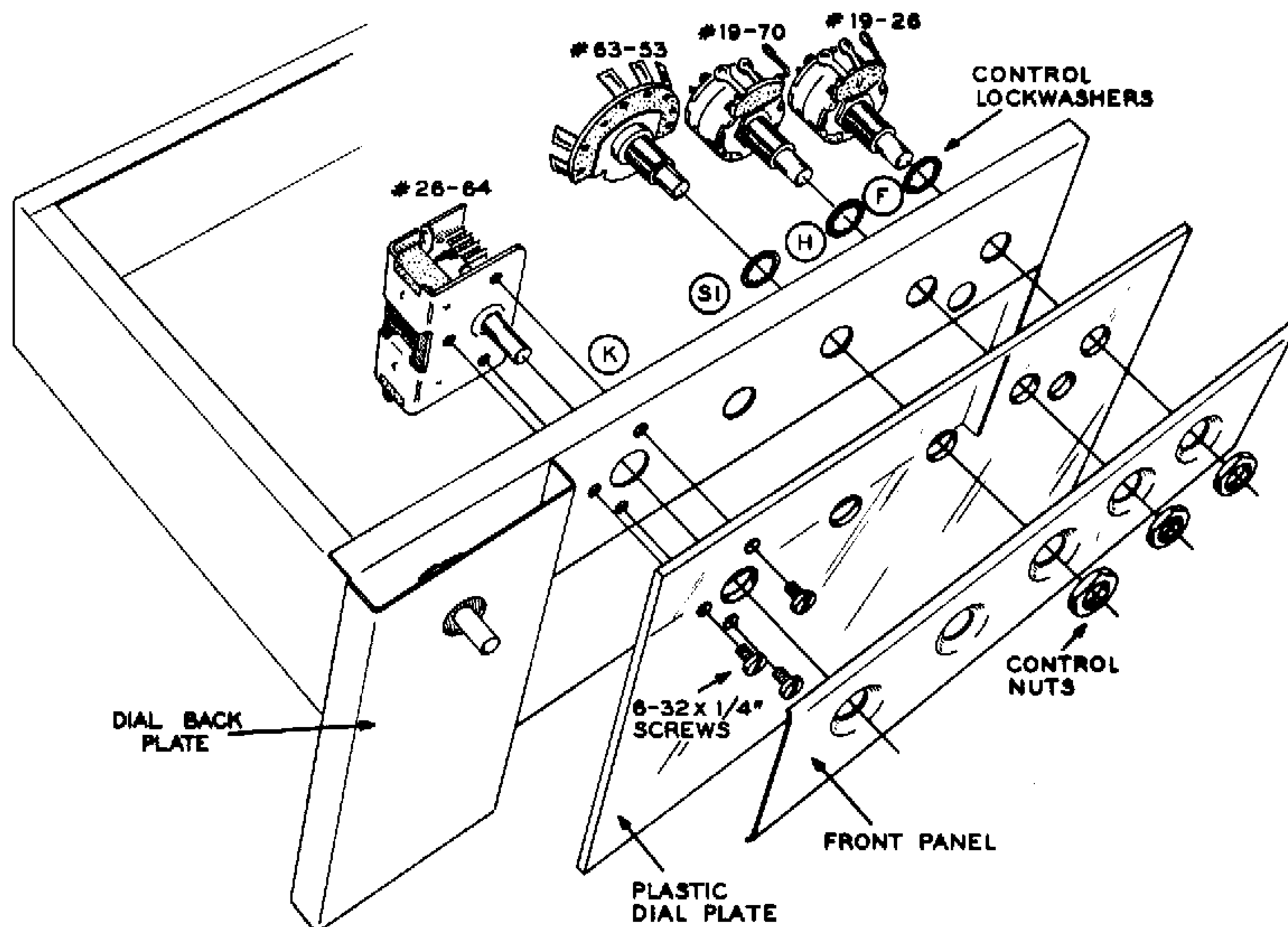

Figure 8

## CIRCUIT BOARD ASSEMBLY

Refer to Circuit Board Wiring And Soldering on Page 10 before proceeding.

Refer to Figure 9 for the following steps.

- ( ) Install two 7-pin tube sockets with shield clip, at locations V2 and V3. On each socket, solder all eight connections and the center post to the foil.
- ( ) Install two 7-pin tube sockets without shield clip at V1 and V4. Solder all seven connections to the foil.

NOTE: Do not use any of the black hookup wire until it is specifically called for. All resistors are 1/2 watt unless specified otherwise. Do not solder any of the leads until told to do so.

The step numbers correspond to the numbers on Figure 9.

1. (✓) R5, 22 K $\Omega$  (red-red-orange) resistor.
2. (✓) L9, 30  $\mu$ h choke.
3. (✓) R4, 150  $\Omega$  (brown-green-brown) resistor.

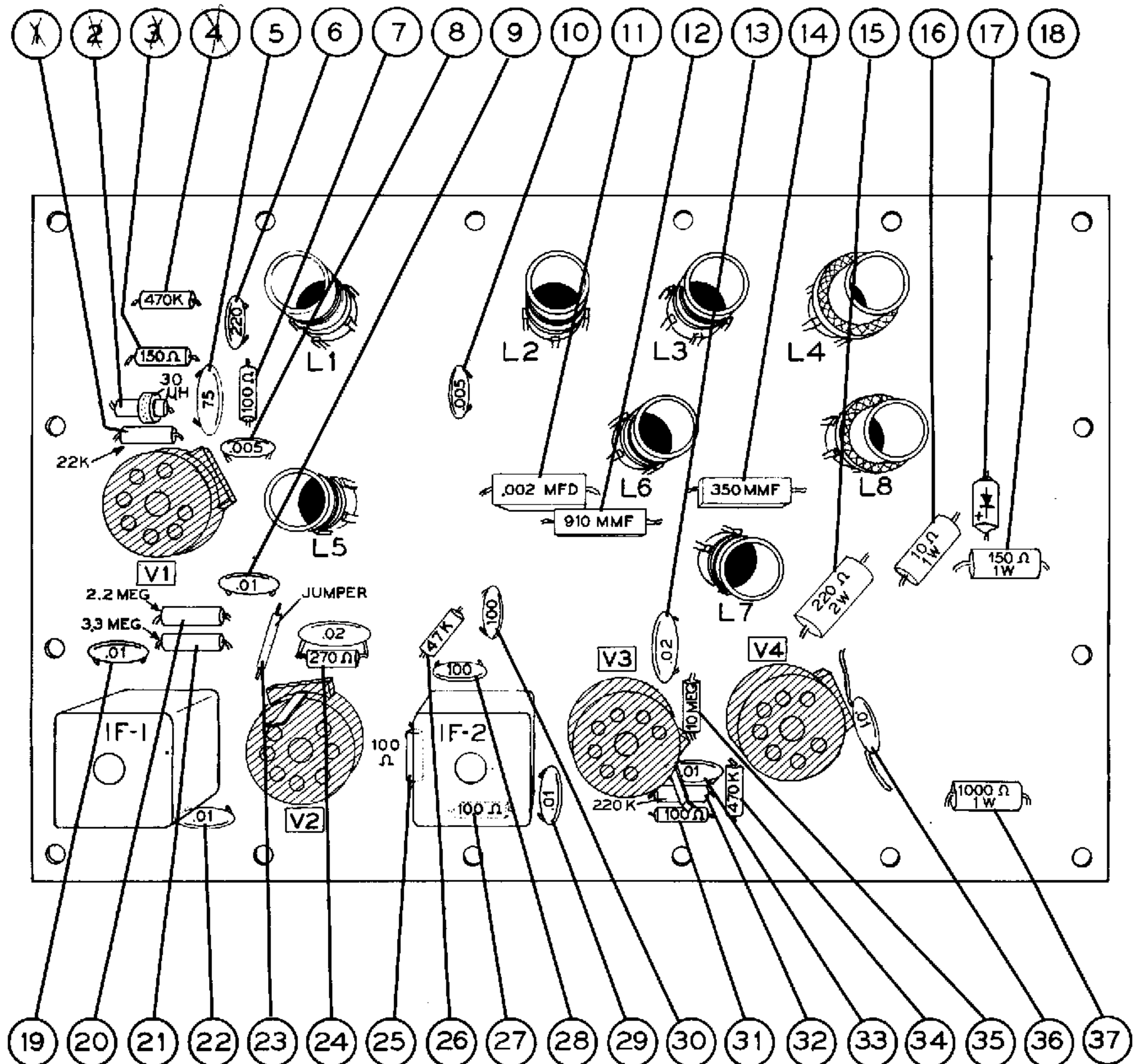
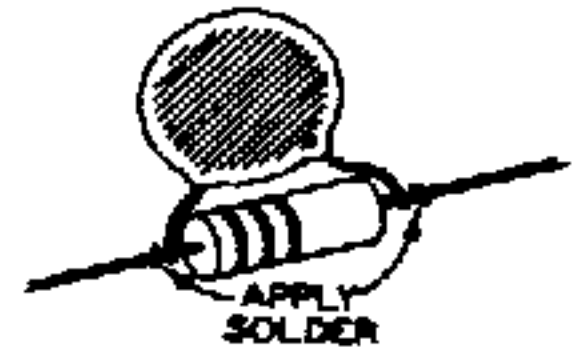

Figure 9

4. (✓) R42. 470 K $\Omega$  (yellow-violet-yellow) resistor.
  5. (✓) C12. 75  $\mu\mu\text{f}$  disc capacitor.
  6. (✓) C11. 220  $\mu\mu\text{f}$  disc capacitor.
  7. (✓) R1. 100  $\Omega$  (brown-black-brown) resistor.
  8. (✓) C10. .005  $\mu\text{fd}$  disc capacitor.
  9. (✓) C14. .01  $\mu\text{fd}$  disc capacitor.
  10. (✓) C7. .005  $\mu\text{fd}$  disc capacitor.
  11. (✓) C1. .002 mfd mica capacitor.
  12. (✓) C2. 910 mmf mica capacitor.
  13. (✓) C22. .02  $\mu\text{fd}$  disc capacitor.
  14. (✓) C3. 350 mmf mica capacitor.
  15. (✓) R22. 220  $\Omega$  (red-red-brown) 2 watt resistor. Leave a 1/8" space between the body of this resistor and the circuit board.
  16. (✓) R21. 10  $\Omega$  (brown-black-black) 1 watt resistor. Leave a 1/8" space between the body of this resistor and the circuit board.
  17. (✓) CR1 Diode. Be sure to position the diode marking as shown.
  18. (✓) R20. 150  $\Omega$  (brown-green-brown) 1 watt resistor. Leave a 1/8" space between the body of this resistor and the circuit board.
  19. (✓) C16. .01  $\mu\text{fd}$  disc capacitor.
  20. (✓) R3. 2.2 megohm (red-red-green) resistor.
  21. (✓) R11. 3.3 megohm (orange-orange-green) resistor.
  22. (✓) C15. .01  $\mu\text{fd}$  disc capacitor.
  23. (✓) 1-1/4" jumper. Use white hookup wire.
  24. (✓) C18, R8. Connect a .02  $\mu\text{fd}$  disc capacitor and a 270  $\Omega$  (red-violet-brown) resistor as shown. Now install this combination on the circuit board.
- 
25. (✓) R6. 100  $\Omega$  (brown-black-brown) resistor.
  26. (✓) R10. 47 K $\Omega$  (yellow-violet-orange) resistor.
  27. (✓) ~~R7~~. 100  $\Omega$  (brown-black-brown) resistor.
  28. (✓) C21. 100  $\mu\mu\text{f}$  disc capacitor.
  29. (✓) C19. .01  $\mu\text{fd}$  disc capacitor.
  30. (✓) C20. 100  $\mu\mu\text{f}$  disc capacitor.
  31. (✓) R17. 100  $\Omega$  (brown-black-brown) resistor.
  32. (✓) R18. 220 K $\Omega$  (red-red-yellow) resistor.
  33. ( ) C23. .01  $\mu\text{fd}$  disc capacitor.
  34. (✓) R19. 470 K $\Omega$  (yellow-violet-yellow) resistor.
  35. (✓) R15. 10 megohm (brown-black-blue) resistor.
  36. (✓) C25. .01  $\mu\text{fd}$  disc capacitor.
  37. ( ) R23. 1000  $\Omega$  (brown-black-red) 1 watt resistor.
- ( ) Solder and cut off the excess leads of all the components. The remaining jumper and capacitor will be installed later.

The "L" and "IF" numbers in the following steps correspond to the "L" and "IF" numbers on the circuit board.

- (→) L1. Band D antenna coil (#40-396).
- (→) L2. Band C antenna coil (#40-395).
- (✓) L3. Band B antenna coil (#40-394).
- (✓) L4. Band A antenna coil (#40-393).
- (✓) L5. Band D oscillator coil (#40-400).
- (→) L6. Band C oscillator coil (#40-399).
- (→) L7. Band B oscillator coil (#40-398).
- (→) L8. Band A oscillator coil (#40-397).
- ( ) IF-1. IF transformer. Note the wider spaced pins.
- (✓) IF-2. IF transformer. Note the wider spaced pins.
- (✓) Solder the six lugs on each IF transformer and the five lugs on each of the eight coils.
- ( ) Refer to Pictorial 1 and install the circuit board under the chassis, using sixteen 6-32 x 3/8" screws, #6 lockwashers, and 6-32 nuts. Prepare the plastic clamp as shown in Figure 10 and install it under the mounting screw at R on the circuit board.

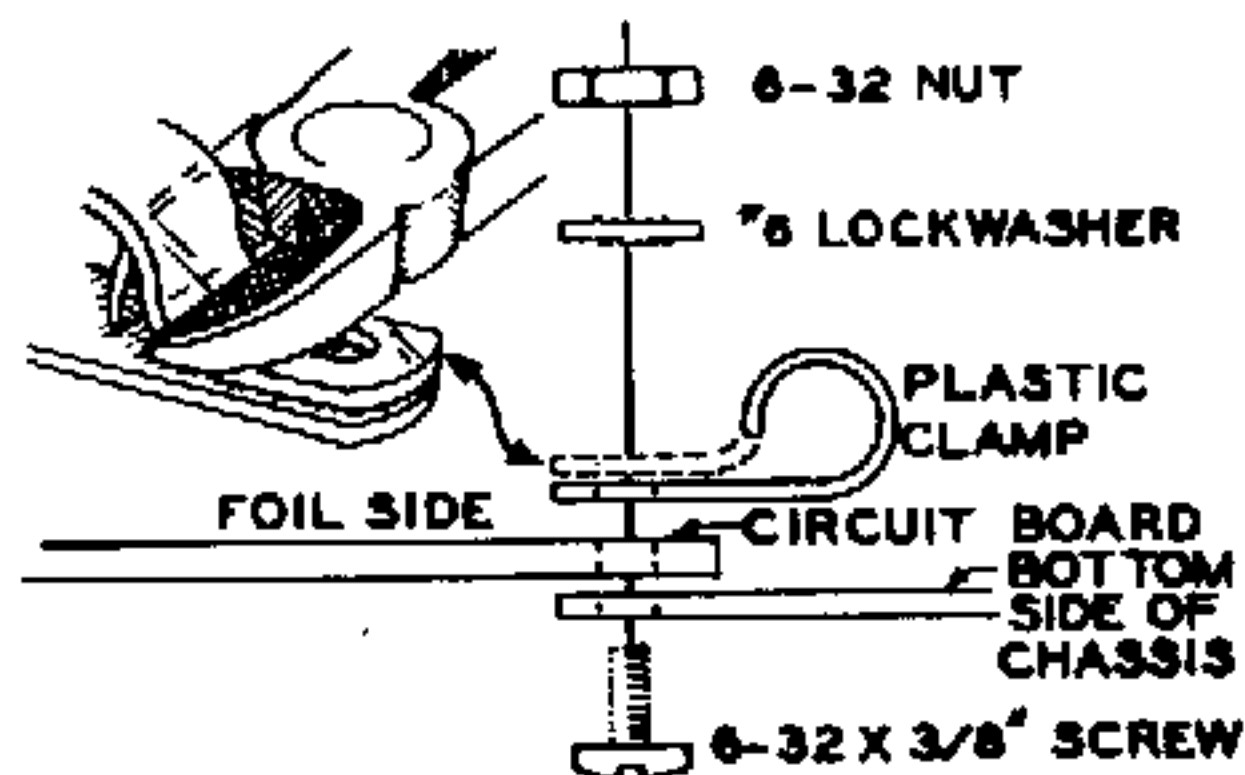

Figure 10

### CHASSIS WIRING

- (✓) T1. Cut the leads of the power transformer (#54-121) to the following lengths (measured from the exit of the transformer):

- | COLOR            | LENGTH |
|------------------|--------|
| (✓) Either black | 2-1/4" |
| (✓) Other black  | 3"     |
| (✓) Both red     | 2-3/4" |
- (✓) Strip 1/4" insulation from the end of each lead and tin. "Tin" means to melt a small amount of solder on the exposed lead end.
  - (✓) T1. Mount the power transformer on top of the chassis at T1 (making sure all four leads go through grommet BB), and mount a 5-lug terminal strip at S under the chassis. Use two 6-32 x 3/8" screws, three #6 lockwashers, and two 6-32 nuts, as shown in Figure 11. Position the terminal strip as shown in Pictorial 1.

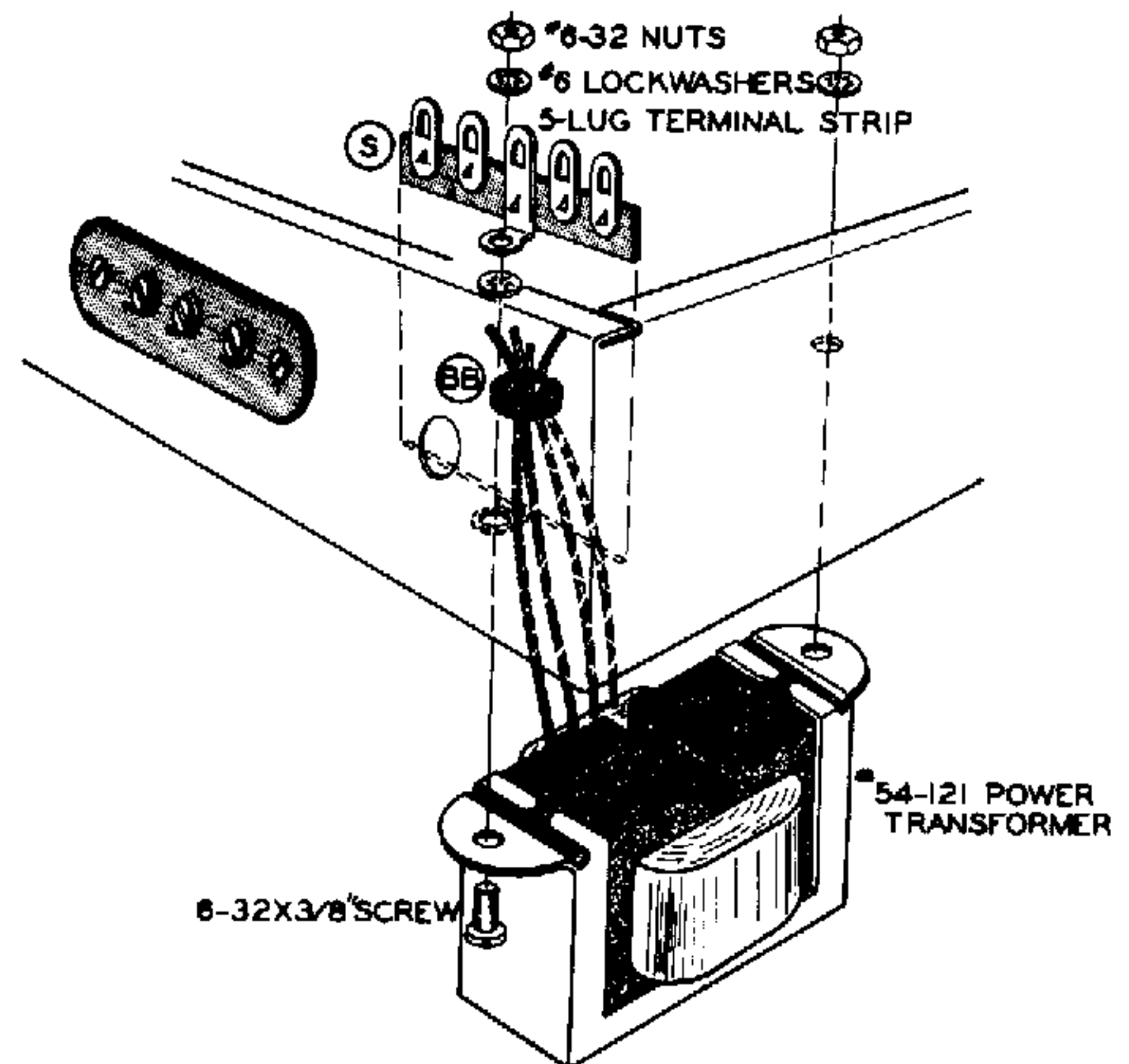

Figure 11

The power transformer leads will be connected in the next three steps. See Pictorial 1.

- (→) Connect the longest black lead coming through grommet BB to lug 5 of terminal strip S (NS).
- (→) Connect the remaining black lead coming through grommet BB to lug 1 of terminal strip S (NS).



(✓) Twist the two red leads together and connect either lead to lug 3 (NS) and the other lead to lug 2 (NS) of terminal strip S.

(✓) T2. Cut the leads of the output transformer (#51-83) to the following lengths:

<u>COLOR</u>	<u>LENGTH</u>
(✓) Red	1-5/8"
(✓) Blue	2"
(✓) Both black	<u>do not cut</u>

(✓) Strip 1/4" of insulation from the end of each insulated lead and tin.

(✓) T2. Mount the output transformer at T2 on top of the chassis with a #6 solder lug at DD as shown in Pictorial 2 (fold-out from Page 33). Use two 6-32 x 3/8" screws, two #6 lockwashers, and two 6-32 nuts. The #6 solder lug goes on top of the chassis, under the mounting screw at DD. Insert one of the black leads through grommet CC. The black leads should be on the outside edge of the chassis.

NOTE: The purpose of using twisted pairs of hookup wire is to provide shielding for signal carrying leads and the cancellation of hum in the filament and AC leads. Best results will be obtained in the following steps if the wires are twisted approximately 3 complete turns per inch. See Figure 12. The wires may be twisted by hand or with a drill as shown. If a drill is used, be careful not to twist the wires too tightly.

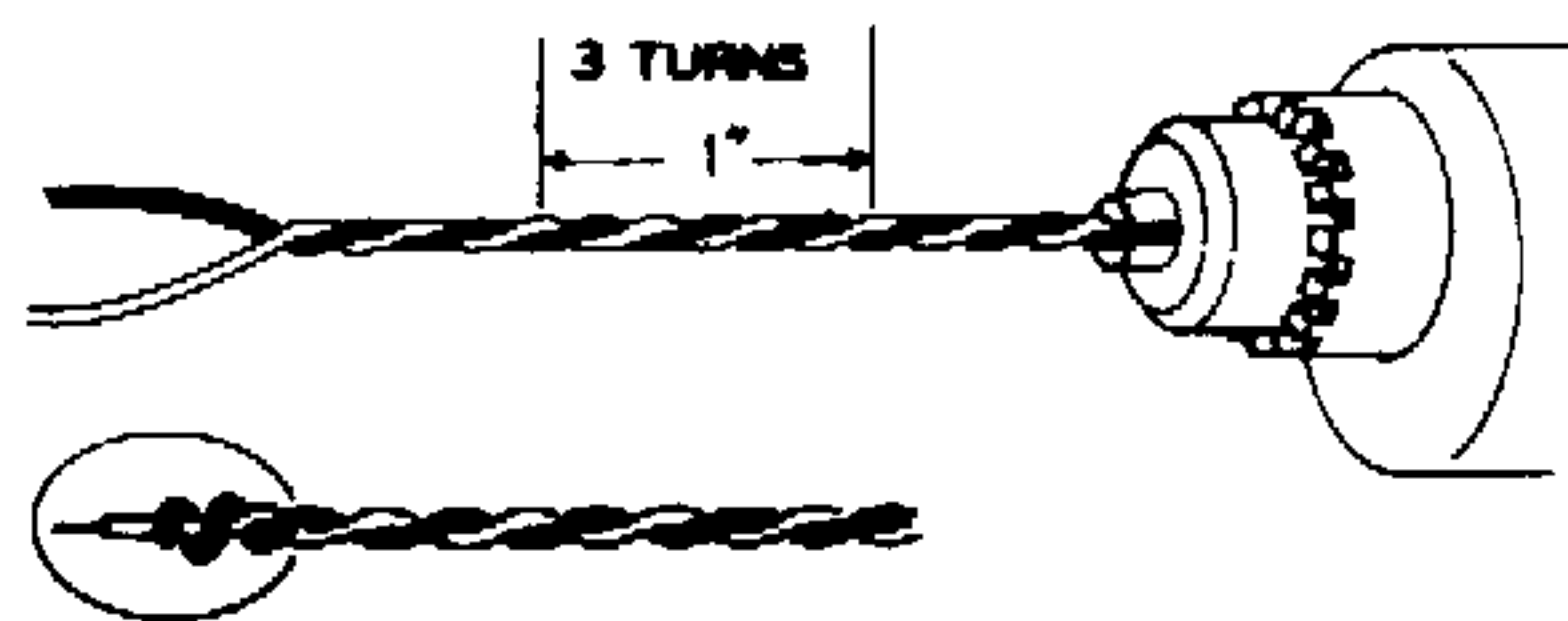

Figure 12

(✓) Cut the white hookup wire to the same length as the black hookup wire. Now twist these two lengths together as shown in Figure 12.

NOTE: When making a connection with hookup wire, 1/4" of insulation should be removed unless directed otherwise in the step.

In the following steps you may wish to cut the lengths of wire ahead of time. The lengths of hookup wire needed for the wiring steps are listed at the beginning of each section. Use the white insulated hookup wire unless bare or twisted wire is specified. Arrange the wires in the sequence listed. This will save time in performing the wiring steps.

The lengths of twisted wires needed in the following steps are:

- (✓) 6" twisted pair.
- (✓) 25" twisted pair.
- (✓) 19-1/2" twisted pair.
- (✓) 12-1/2" twisted pair.
- (✓) 15" twisted pair.
- (✓) 12" twisted pair.
- (✓) 14" twisted pair.
- (✓) 12-1/2" twisted pair.
- (✓) 10" twisted pair.
- (✓) 12" twisted pair.
- (✓) Insert one end of a 6" twisted pair through grommet AA from the bottom of the chassis to be connected later.
- (✓) At the other end of this twisted pair, connect the white wire to lug 2 of control Q (S-1) and the black wire to lug 1 of terminal strip N (NS).

NOTE: Refer to Pictorial 1 and the top of the circuit board when wiring the bottom of the circuit board. This will facilitate locating the holes as they are wired in the following steps.

- (✓) At one end of a 25" twisted pair, connect the white wire to lug 2 (S-2) and the black wire to lug 3 (S-2) on terminal strip S.
- (✓) At the other end of this twisted pair, connect the black wire to hole SW-1 (S-1) and the white wire to hole SW-2 (S-1) on the circuit board. Position this pair of wires around the chassis as shown in Pictorial 1.

(✓) At one end of a 19-1/2" twisted pair, connect the white wire to lug 1 (S-2) and the black wire to lug 4 (NS) of terminal strip S.

(✓) At the other end of this twisted pair, connect the white wire to lug 4 (S-1) and the black wire to lug 5 (S-1) of control F. Position this twisted pair along the chassis as shown.

NOTE: In the following steps the black wire may not be connected at one end of the twisted pair. If the black wire is not connected, it serves as a shield for the white wire and should be wrapped around the end of the white wire as shown in the inset in Figure 12.

(✓) At one end of a 12-1/2" twisted pair, connect the white wire to hole SW2 #3 (S-1) and the black wire to the ground ( $\perp$ ) hole (S-1) (near the SW2 #3 hole) on the circuit board.

(✓) At the other end of this twisted pair, connect the white wire to lug 4 of switch S1 (S-1). The black wire is not connected at this end.

(✓) At one end of a 15" twisted pair, connect the white wire to hole SW2 #1 (S-1) and the black wire to the center post of tube socket V2 (S-1) on circuit board. Position the twisted pair through the plastic clamp as shown.

(✓) At the other end of this twisted pair, connect the white wire to lug 5 of control H (NS). The black wire is not connected at this end.

(✓) At one end of a 12" twisted pair, connect the white wire to hole SW2 #2 (S-1) and the black wire to the ground ( $\perp$ ) hole (S-1) (near the SW2 #2 hole) on the circuit board. Position this twisted pair through the plastic clamp as shown.

(✓) At the other end of this twisted pair, connect the white wire to lug 8 of switch S1 (S-1). The black wire is not connected at this end.

(✓) At one end of a 14" twisted pair connect the white wire to the AVC hole (S-1) and the black wire to the ground ( $\perp$ ) hole (S-1) (near the AVC hole) on the circuit board.

Position this twisted pair approximately 1-1/2" above the circuit board and along the side of the chassis as shown.

(✓) At the other end of this twisted pair, connect the white wire to lug 3 of control F (S-1). The black wire is not connected at this end.

(✓) At one end of a 12-1/2" twisted pair, connect the white wire to the AUDIO hole (S-1) and the black wire to the ground ( $\perp$ ) hole (S-1) (near the AUDIO hole) on the circuit board. Position this twisted pair approximately 1-1/2" above the circuit board and along the side of the chassis as shown.

(✓) At the other end of this twisted pair, connect the white wire to lug 2 of control F (S-1). The black wire is not connected at this end.

(✓) At one end of a 10" twisted pair, connect the white wire to hole F-2 (S-1) and the black wire to hole F-1 (S-1) on the circuit board. Position this twisted pair as shown.

(✓) At the other end of this twisted pair, connect the white wire to lug 3 (NS) and the black wire to lug 4 (NS) of terminal strip J.

(✓) Locate the two pilot lamp sockets and insert a #47 lamp in each socket.

(✓) Using a 6-32 x 3/8" screw, #6 lockwasher, and 6-32 nut, mount a pilot lamp socket at G. The lamp should go through the chassis hole directly in front of the socket.

(✓) Similarly, mount the other pilot lamp socket at L using a 6-32 x 3/8" screw, #6 lockwasher, and a 6-32 nut. Make sure the twisted wires are underneath the lamps. See Pictorial 1.

(✓) Twist together the two wires coming from pilot lamp socket G. Connect the white wire to lug 1 (NS) and the black wire to lug 2 (NS) of terminal strip J.

(✓) Twist together the two wires coming from pilot lamp socket L. Connect the black wire to lug 2 (S-2) and the white wire to lug 4 (NS) of terminal strip J.



- ( ✓ ) R25. Connect the 600  $\Omega$  5 watt resistor from lug 1 (NS) to lug 4 (S-3) of terminal strip J.
- ( ✓ ) R24. Connect the 880-100  $\Omega$  glo-bar resistor from lug 1 (S-3) to lug 3 (S-2) of terminal strip J.
- ( ) At one end of a 12" twisted pair, connect the white wire to lug 1 of control Q (NS) and the black wire to lug 1 of terminal strip N (NS). Route this twisted pair through the plastic clamp as shown.
- ( ) At the other end of this twisted pair, connect the white wire to hole M-2 (S-1) and the black wire to IF-2 transformer pin near hole M-1 on the circuit board (S-1). Wrap this wire around the IF transformer pin. Do not use hole M-1.
- ( ) Turn the chassis over and cut off the excess wire lengths that may be protruding through the top of the circuit board.

NOTE: All resistors are 1/2 watt unless specified otherwise.

- ( ✓ ) R12. Connect a 1000  $\Omega$  (brown-black-red) resistor from lug 1 of terminal strip N (S-3) to lug 1 of control Q (S-2).
- ( ✓ ) R14. Connect a 68 K $\Omega$  (blue-gray-orange) resistor from lug 2 of terminal strip N (S-1) to lug 3 of control Q (S-1).
- ( ✓ ) C17. Connect a .01  $\mu$ fd disc capacitor from lug 1 of phono socket X (S-1) to IF-1 transformer pin near hole QM on the circuit board (S-1). Wrap this lead around the IF transformer pin. Do not use hole QM.

The lengths of wire needed in the following steps are:

- |                   |  |                   |
|-------------------|--|-------------------|
| ( ✓ ) 1-3/4" bare |  | ( ✓ ) 3-1/4" bare |
| ( ✓ ) 1-1/2" bare |  | ( ✓ ) 1-3/4" bare |
| ( ✓ ) 6" white    |  | ( ✓ ) 3" bare     |
| ( ✓ ) 3" bare     |  |                   |

- ( ✓ ) Connect a 1-3/4" bare wire from lug 2 on slide switch Y (S-1) to hole NL on the circuit board (S-1). This hole is to the right of the slide switch as viewed in Pictorial 1.

- ( ✓ ) Connect a 1-1/2" bare wire from lug 1 on the slide switch Y (S-1) to hole NL on the circuit board (S-1). This hole is to the left of the slide switch as viewed in Pictorial 1.
- ( ✓ ) Connect the black lead coming through grommet CC from the output transformer to lug 2 on the phone jack Z (S-1).
- ( ✓ ) Connect a 6" wire to lug 1 of phone jack Z (S-1). Insert the other end of this wire through grommet CC to be connected later.
- ( ✓ ) Insert one end of a 3" bare wire through lug 5 (NS) to lug 1 (S-1) of switch S1.
- ( ✓ ) Connect the other end of this wire to lug 7 of switch S1 (S-1). Position this wire away from the switch contacts.
- ( ✓ ) Insert one end of a 3-1/4" bare wire through lug 1 of control H (NS), to lug 1 of control F (NS).
- ( ✓ ) Connect the other end of this wire to lug 4 of control H (S-1). Position this wire so that it does not touch any of the control lugs.
- ( ✓ ) Connect a 1-3/4" bare wire from lug 2 (S-1) to lug 5 (S-2) of control H. Position this wire away from the control.
- ( ) Connect a 3" bare wire from lug 1 of control H (S-3) to lug 5 of switch S1 (S-3). Position this wire away from the control lugs and the wire just installed.

### BAND SWITCH WIRING AND INSTALLATION

- ( ) Locate the 4-position, 2-section rotary switch (#63-286) and position it as shown in Figure 13.

The lengths of wire needed for the following steps are:

- |                 |  |                 |
|-----------------|--|-----------------|
| ( ) 1-1/4" bare |  | ( ) 1-3/8" bare |
| ( ) 1-1/2" bare |  | ( ) 2-1/8" bare |
| ( ) 2-1/4" bare |  | ( ) 2-1/8" bare |
| ( ) 1" bare     |  |                 |

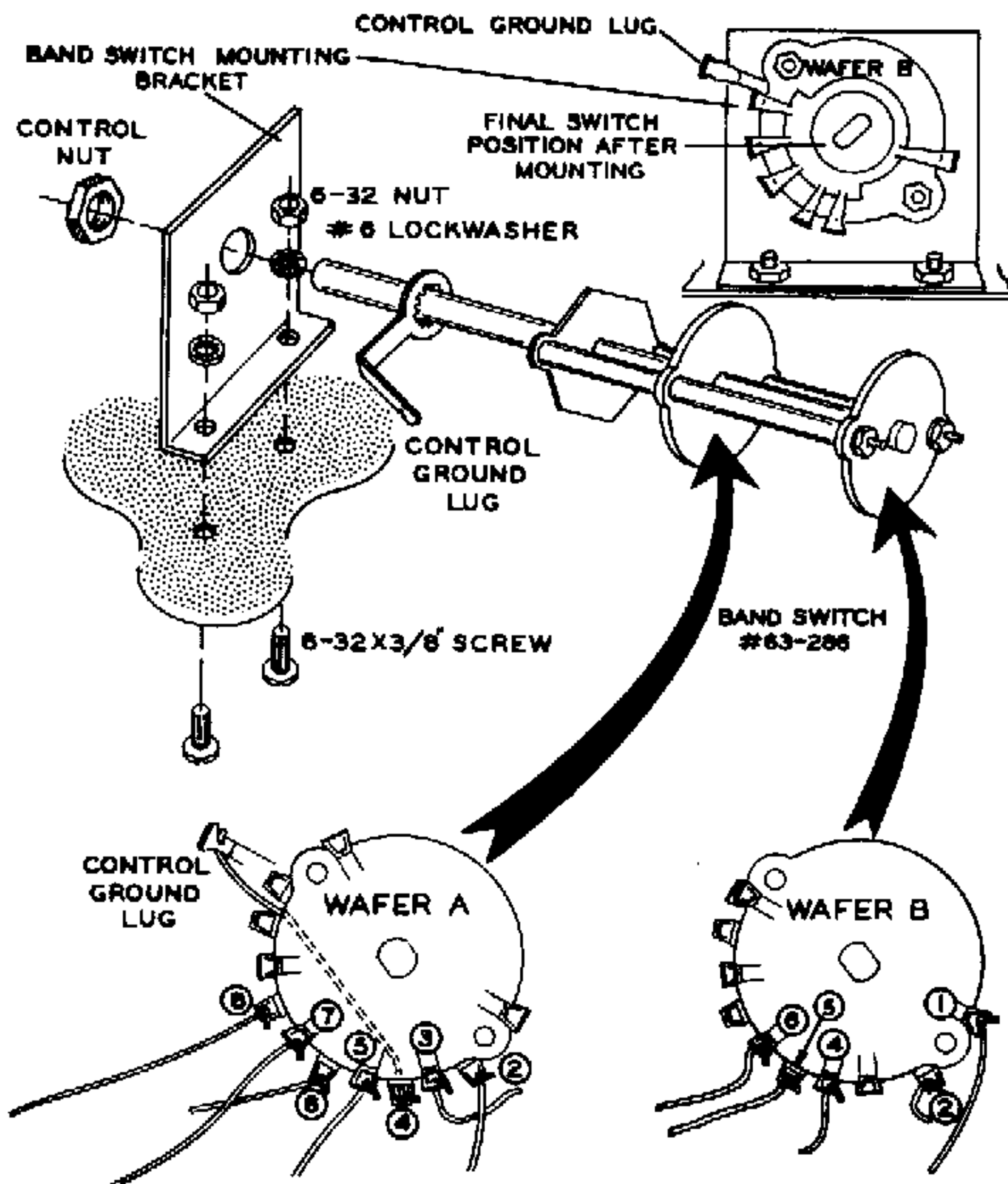

Figure 13

Wafer A will be prewired in the next seven steps. This is the wafer closest to the shaft end of the switch.

CONNECT                      TO LUG

- (✓) 1-1/4" bare wire    2 (S-1).
- (✓) 1-1/2" bare wire    3 (S-1).
- (✓) 2-1/4" bare wire    4 (S-1).
- (✓) 1" bare wire        5 (S-1).
- (✓) 1-3/8" bare wire    6 (S-1).
- (✓) 2-1/8" bare wire    7 (S-1).
- (✓) 2-1/8" bare wire    8 (S-1).

The lengths of wire needed in the following steps are:

- |                 |  |                 |
|-----------------|--|-----------------|
| (✓) 1-1/2" bare |  | (✓) 1-1/2" bare |
| (✓) 7/8" bare   |  | (✓) 1" bare     |
| (✓) 7/8" bare   |  |                 |

Wafer B will be prewired in the next five steps.

CONNECT                      TO LUG

- (✓) 1-1/2" bare wire    1 (S-1).
- (✓) 7/8" bare wire       2 (S-1).
- (✓) 7/8" bare wire       4 (S-1).
- (✓) 1-1/2" bare wire    5 (S-1).
- (✓) 1" bare wire         6 (S-1).

(✓) Locate the BAND switch mounting bracket, and mount the BAND switch to the bracket, using a control ground lug, and control nut as shown in Figure 13. Position the switch and control ground lug as shown.

(✓) Mount the BAND switch with the mounting bracket to the chassis using two 6-32 x 3/8" screws, #6 lockwashers, and 6-32 nuts as shown in Figure 13.

Refer to Figure 14 for the following steps.

Wafer A wiring will be completed in the following steps.

- (✓) Connect the wire from lug 3 to hole DA-2 on the circuit board (S-1).
- (✓) Connect the wire from lug 2 to hole DA-3 on the circuit board (S-1).
- (✓) Connect the wire from lug 4 to the control ground lug (NS).
- (✓) Connect the wire from lug 5 to hole CP on the circuit board (S-1).
- (✓) Connect the wire from lug 6 to hole CS on the circuit board (S-1).
- (✓) Connect the wire from lug 7 to hole BP on the circuit board (S-1).
- (✓) Connect the wire from lug 8 to hole BS on the circuit board (S-1).

The lengths of wire needed in the following steps are:

- |                 |  |                 |
|-----------------|--|-----------------|
| (✓) 2-5/8" bare |  | (✓) 2" bare     |
| (✓) 3-1/4" bare |  | (✓) 2" bare     |
| (✓) 2-3/4" bare |  | (✓) 2-3/4" bare |
| (✓) 1-1/2" bare |  | (✓) 2" bare     |

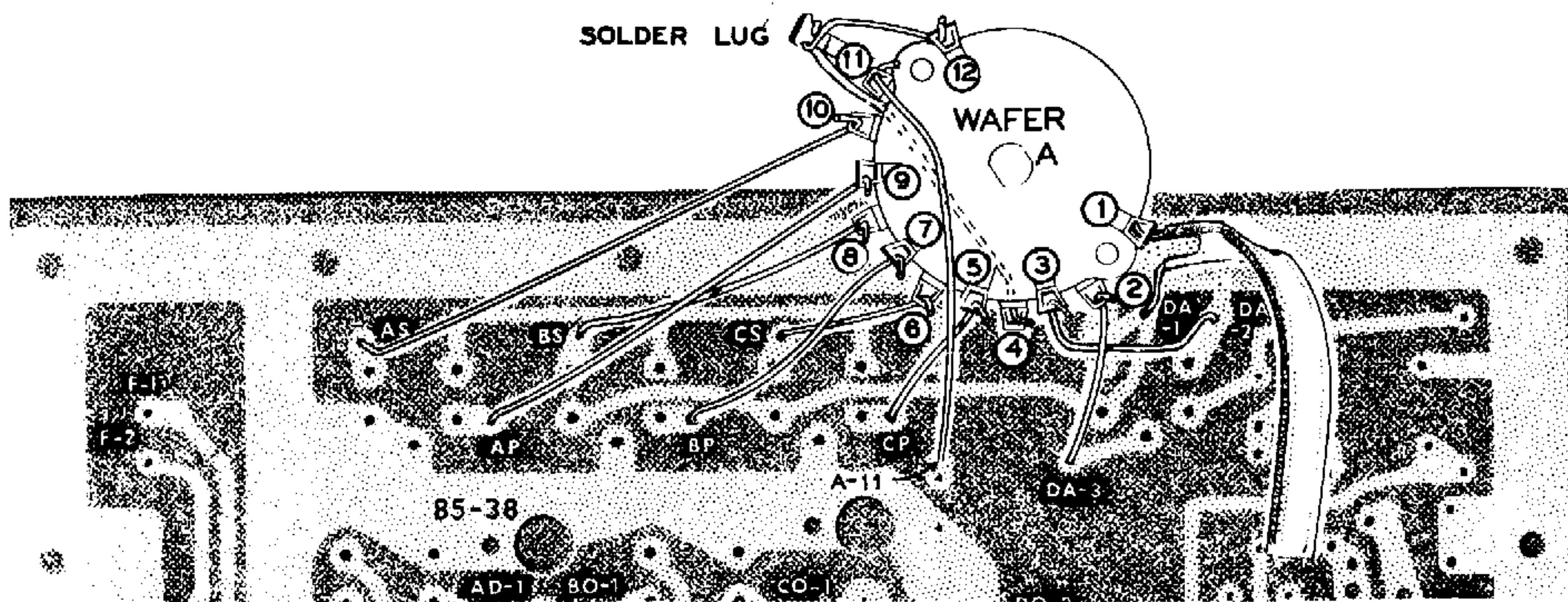

Figure 14

- ( ) Connect a 2-5/8" bare wire from lug 9 (S-1) on wafer A to hole AP on the circuit board (S-1).
- ( ) Connect a 3-1/4" bare wire from lug 10 of wafer A (S-1) to hole AS on the circuit board (S-1).
- ( ) Insert one end of a 2-3/4" bare wire through hole A-11 from the top of the circuit board (NS) and connect the end of this wire to lug 11 of wafer A (S-1). Position this wire so that it does not touch any of the switch contacts.
- ( ) On top of the circuit board, insert the other end of this wire into the jumper hole in the circuit board. Solder both circuit board connections.
- ( ) Connect a 1-1/2" bare wire from lug 12 of wafer A (S-1) to the control ground lug (S-2).
- ( ) Connect the wire coming from lug 6 to hole BO-2 on the circuit board (S-1).
- ( ) Connect a 2" bare wire from lug 7 on wafer B (S-1) to hole BO-1 on the circuit board (S-1).
- ( ) Connect a 2" bare wire from lug 8 on wafer B (S-1) to hole AO-2 on the circuit board (S-1).
- ( ) Connect a 2-3/4" bare wire from lug 9 on wafer B (S-1) to hole AD-1 on the circuit board (S-1).
- ( ) Insert one end of a 2" bare wire through lug 10 (NS) and lug 3 (NS) on wafer B to the ground (  $\equiv$  ) hole directly under lug 3 on the circuit board (S-1). Now solder lug 10 (S-1) and lug 3 (S-2) on wafer B. Position this wire away from the switch contacts.

In the following steps, wafer B of the BAND switch will be wired. See Figure 15.

- ( ) Connect the wire coming from lug 2 to hole DO-2 on the circuit board (S-1).
- ( ) Connect the wire coming from lug 1 to hole DO-1 on the circuit board (S-1).
- ( ) Connect the wire coming from lug 4 to hole CO-2 on the circuit board (S-1).
- ( ) Connect the wire coming from lug 5 to hole CO-1 on the circuit board (S-1).

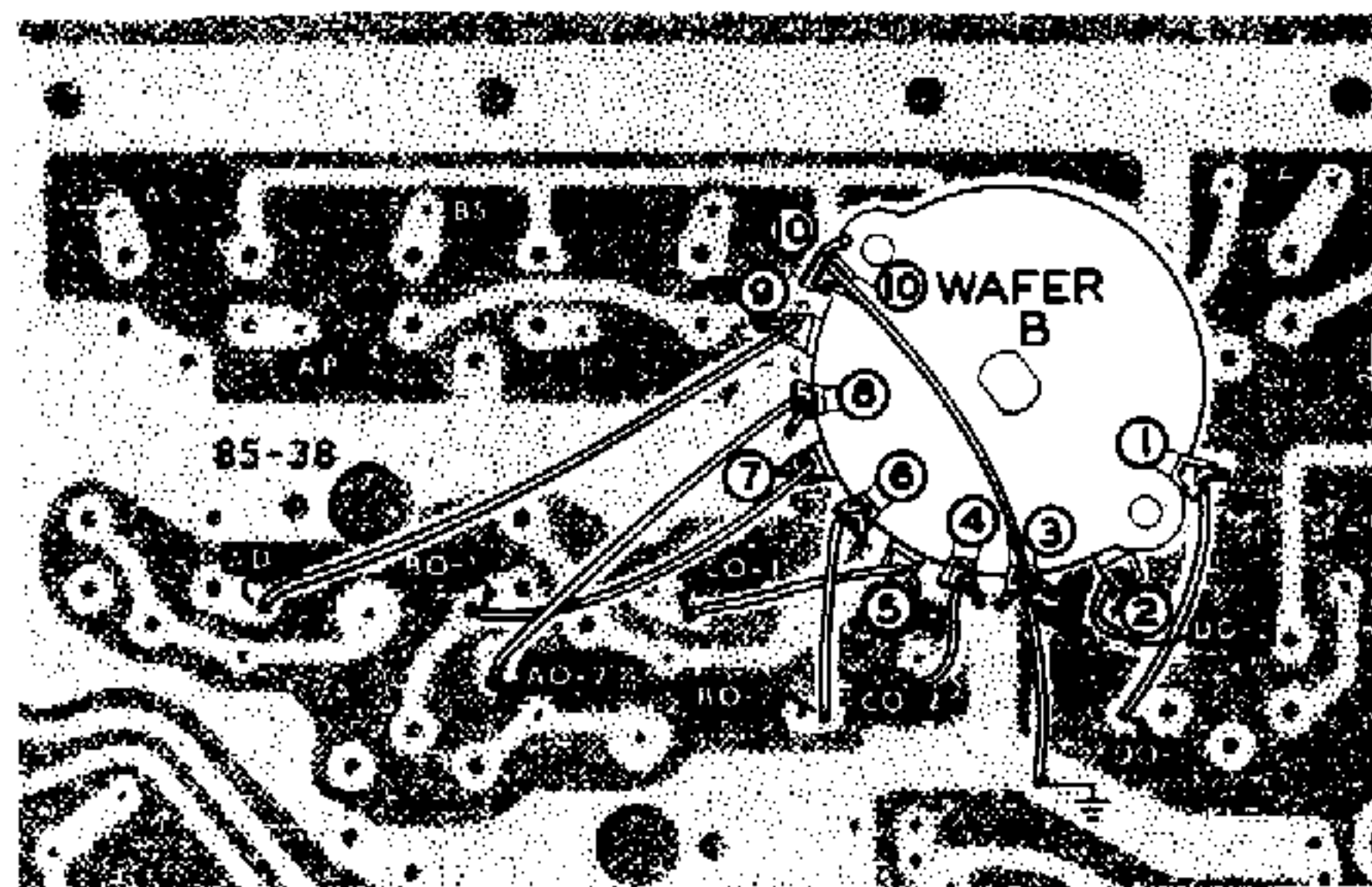

Figure 15

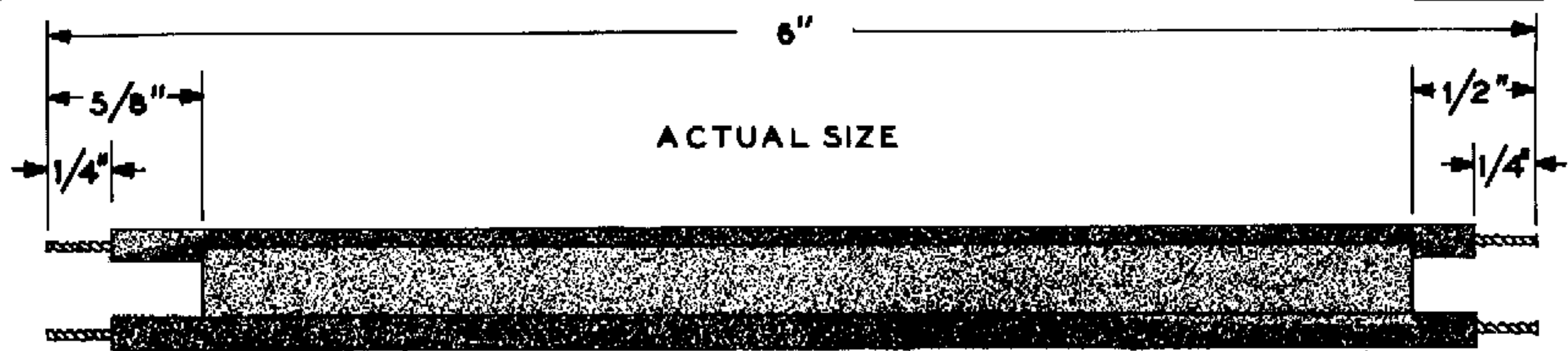

Figure 16

- (✓) Locate the length of 300 Ω twin lead and prepare it as shown in Figure 16.
- (✓) At the end with 5/8" of insulation removed, connect either wire to lug 1 of wafer A on the BAND switch (S-1). Connect the other wire to hole DA-1 on the circuit board (S-1).
- (✓) At the other end of this lead connect the wire coming from the BAND switch to lug 1 (S-1) and the remaining wire to lug 2 (S-1) of terminal strip W.
- (✓) Solder the #6 solder lug to lug 3 on 3-lug terminal strip W (S-1). It may be necessary to loosen and retighten the mounting screw to position this ground lug properly for soldering.
- (✓) Connect a 1" length of bare wire to the lug on each brass sleeve (S-1).
- (✓) Slip a brass sleeve over A TRIMMER and place the wire into hole AA on the circuit board (S-1).
- (✓) Similarly, slip a brass sleeve over B TRIMMER and place the wire into hole BB on the circuit board (S-1).
- (✓) Similarly, slip the remaining brass sleeve over C TRIMMER and place the wire into hole CC on the circuit board (S-1).
- ( ) Referring to Figure 17, adjust the height of the screw on A TRIMMER, B TRIMMER, and C TRIMMER, as shown.

The lengths of wire needed for the following steps are:

- (✓) Three 1" bare || (✓) 5-1/2" white
- (✓) 5" white || (✓) 1-3/4" bare

- (✓) Locate the three plastic trimmer capacitors and temporarily remove the brass sleeve from each one.
- (✓) C6, C5, C4. Insert a plastic trimmer in hole A TRIMMER, B TRIMMER, and C TRIMMER from the bottom of the circuit board, see Figure 17, and solder the tab as shown.
- At this time the chassis should be set aside for use later.
- Refer to Pictorial 2 (fold-out from Page 33) for the following steps.
- (✓) Locate the TUNING capacitor mounting bracket and insert three 3/16" rubber grommets in the three large holes on the bracket, as shown in Figure 18.
- (✓) Make sure the plates of the TUNING capacitor are fully meshed and position it, with the mounting holes up, on your working area. See Figure 18.
- (✓) Lay three flat washers over the TUNING capacitor mounting holes.
- ( ) Carefully position the TUNING capacitor mounting bracket on the MAIN TUNING capacitor as shown in Figure 18, and secure with three 6-32 x 3/8" screws, three 1/2" flat washers, and a #6 solder lug. The solder lug goes under the mounting screw at EE.

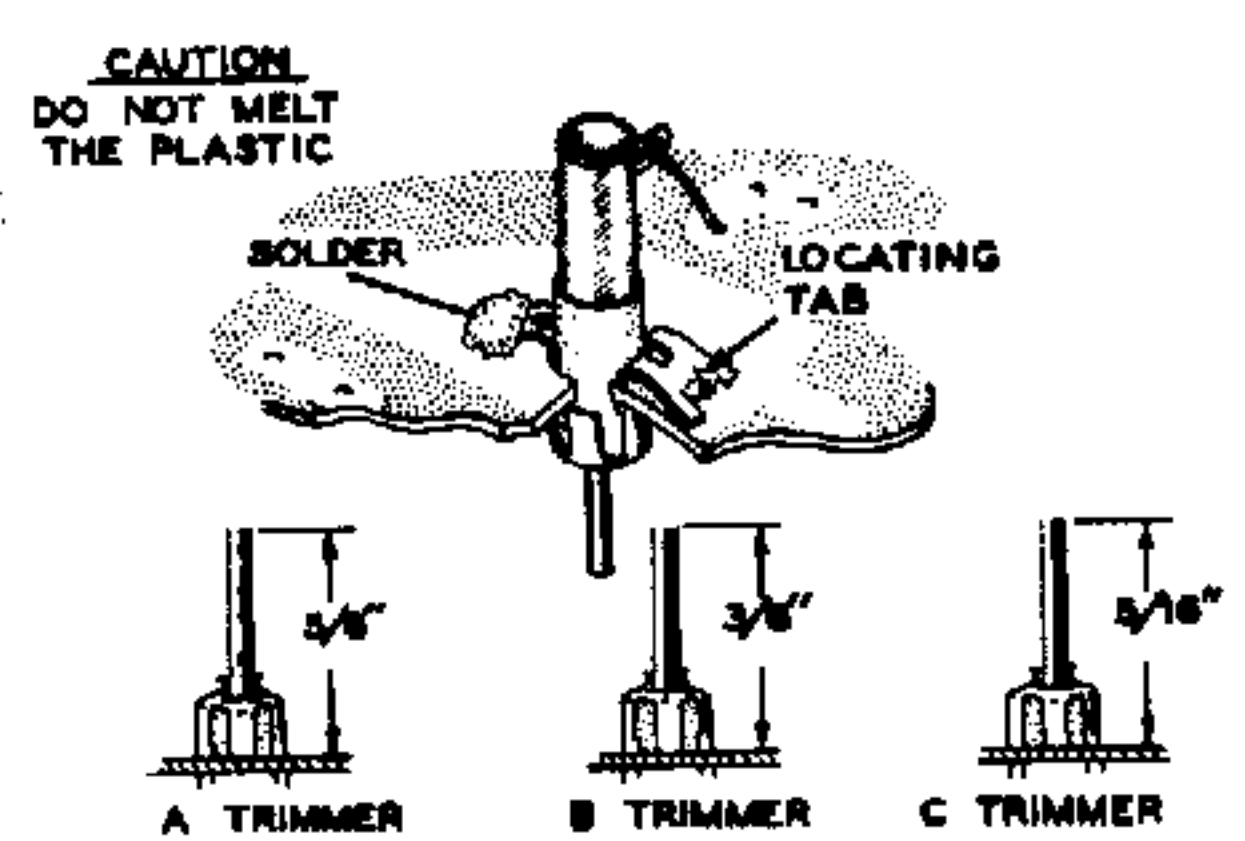

Figure 17

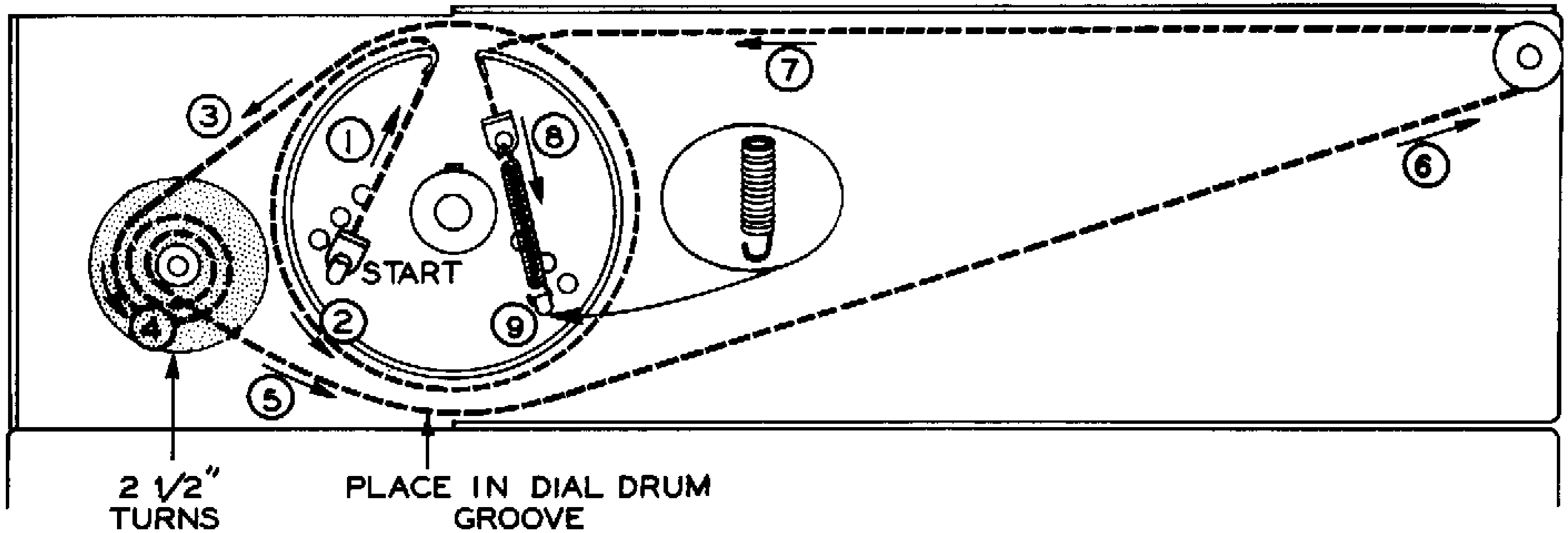

Figure 20

- (✓) Locate the dial pointer and slightly spread the two outer ears as shown in Figure 20A.

Figure 20A



- (✓) Insert the pointer between the plastic dial and dial back plate at the dial drum end and slide the pointer over the lip of the dial back plate. See Figure 20B.

Figure 20B

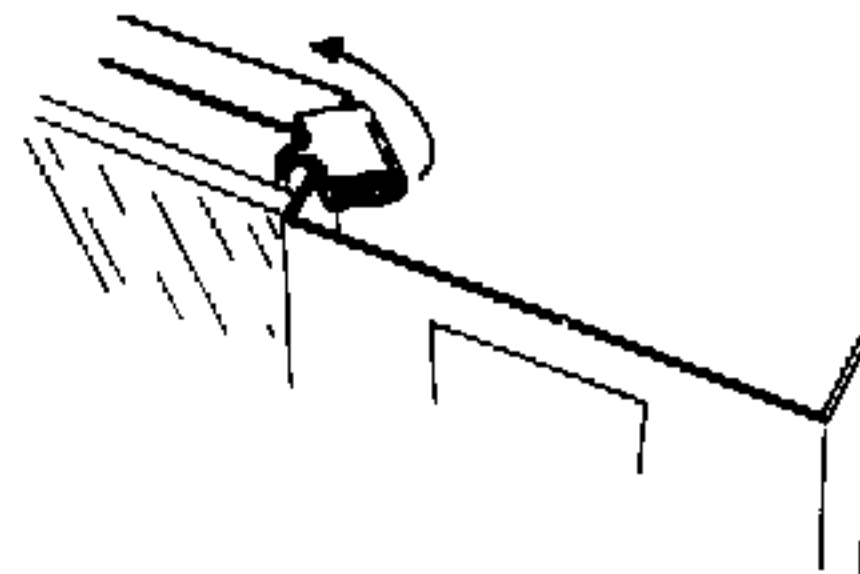

- ( ) Make sure the plates of the MAIN TUNING capacitor are fully meshed and the hole in the outer edge of the dial drum is straight up, as shown in Figure 20. Now tighten the setscrew in the dial drum bushing. The dial drum should be even with the end of the MAIN TUNING capacitor shaft.
- ( ) Locate the dial cord and the dial cord spring. Connect the dial cord spring to the eyelet at one end of the dial cord. At the other end of the dial cord spring, make a small hook as shown in the inset in Figure 20.
- ( ) Referring to Figure 20, string the dial cord starting at 1.

- (✓) With the MAIN TUNING capacitor fully meshed, position the pointer over the vertical line at the beginning of each band marking and crimp the ears over the dial cord. Do not use too much pressure or the ears may cut the dial cord. See Figure 20C.

Figure 20C

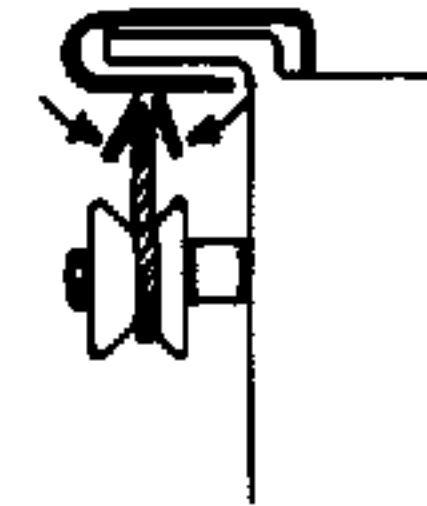

By turning the TUNING capacitor shaft, position the pointer all the way to the right end of the dial. Be sure the pointer ears hit the dial drum. This is the right edge pointer stop. If the pointer ears do not hit the center of the dial drum, reposition the dial drum on the TUNING capacitor shaft so they do.

- (✓) Mount the meter in the position shown in Pictorial 2. The positive (+) lug goes toward the dial drum. Hold the meter against the panel, and slip the clamp over the rear of the meter. With a screwdriver, push both sides of the clamp tightly against the panel as shown in Figure 21.

**IMPORTANT:** The following NOTE and two steps concern using clips on the wires for the meter lugs. However, the meter supplied with your kit may have lugs larger than the clips. In this case, solder the meter wires directly to the meter lugs. Be sure to connect the proper wire to each lug, and do not use excessive heat when soldering.

**NOTE:** To prevent the clip from filling with solder when soldering a wire to it, grasp the

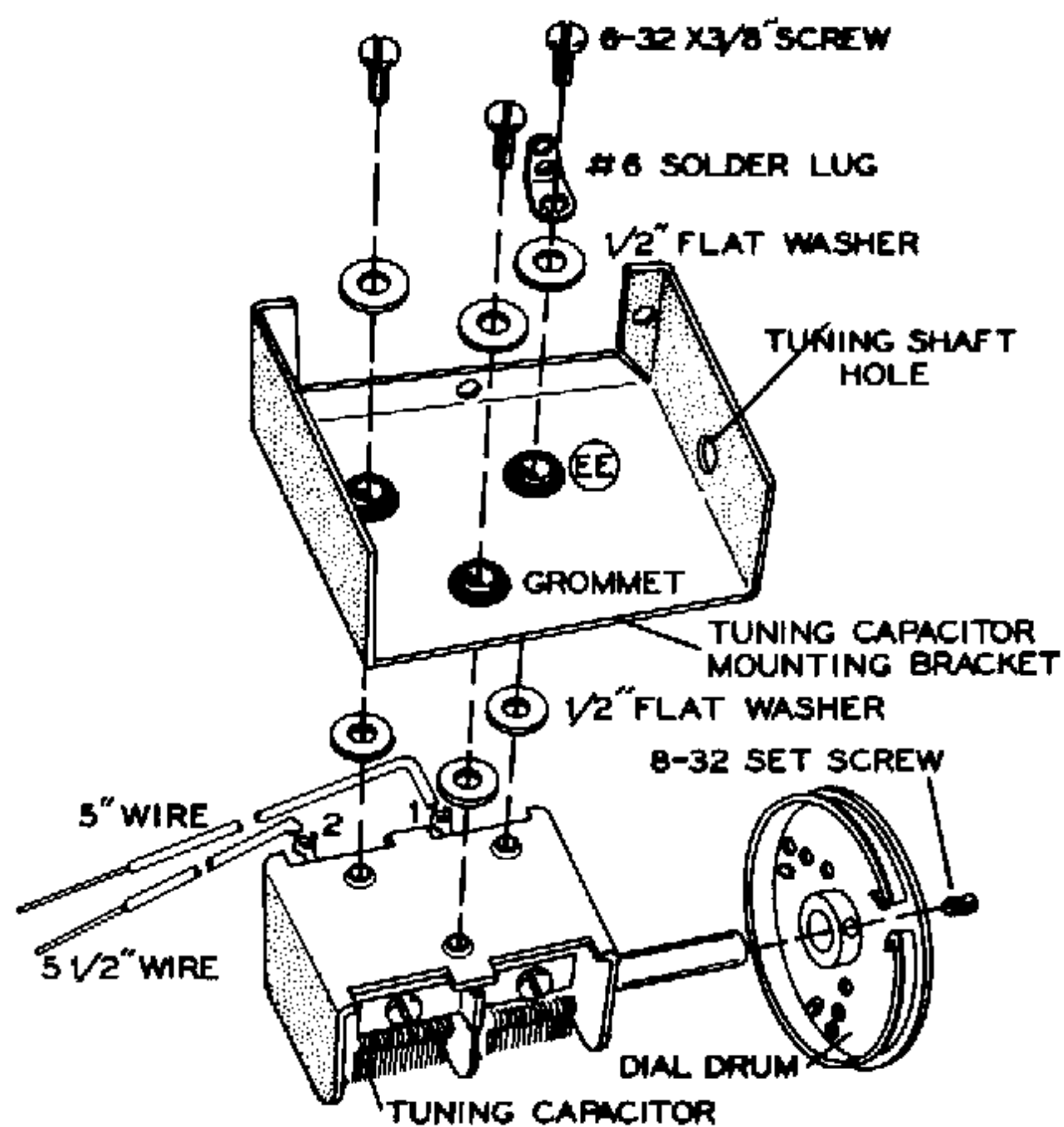

Figure 18

( ) Mount the MAIN TUNING capacitor assembly on the chassis, using three 6-32 x 3/8" screws, one #6 solder lug, three #6 lock-washers, and three 6-32 nuts as shown in Figure 19. The solder lug goes under the mounting screw at FF. Insert the wire from lug 1 through the ANT hole and insert the wire from lug 2 through the OSC hole in the circuit board to be soldered later. See Pictorial 2.

(✓) Bend solder lugs FF and EE so they touch each other. Solder EE and FF together (S-1).

(✓) Referring to Figure 19, insert the two 6-32 setscrews in the flywheel. Insert the shaft through the brass bushing, through the flywheel hole, and into the hole on the TUNING capacitor mounting bracket. Insert the E ring in the slot on the shaft. The E ring should be on the flywheel side of the TUNING capacitor mounting bracket.

(✓) Locate the dial drum and an 8-32 setscrew. Install the setscrew into the dial drum bushing.

(✓) Install the dial drum on the TUNING capacitor shaft, with the bushing toward the TUNING capacitor frame. Do not tighten the setscrew yet.

(✓) Strip 1/4" insulation from one end and 3-1/2" of insulation from the other end of a 5" wire.

(✓) Connect the end with the 1/4" insulation removed to lug 1 of the TUNING capacitor (S-1).

(✓) Strip 1/4" insulation from one end and 4" of insulation from the other end of a 5-1/2" wire.

(✓) Connect the end with the 1/4" insulation removed to lug 2 of the TUNING capacitor (S-1).

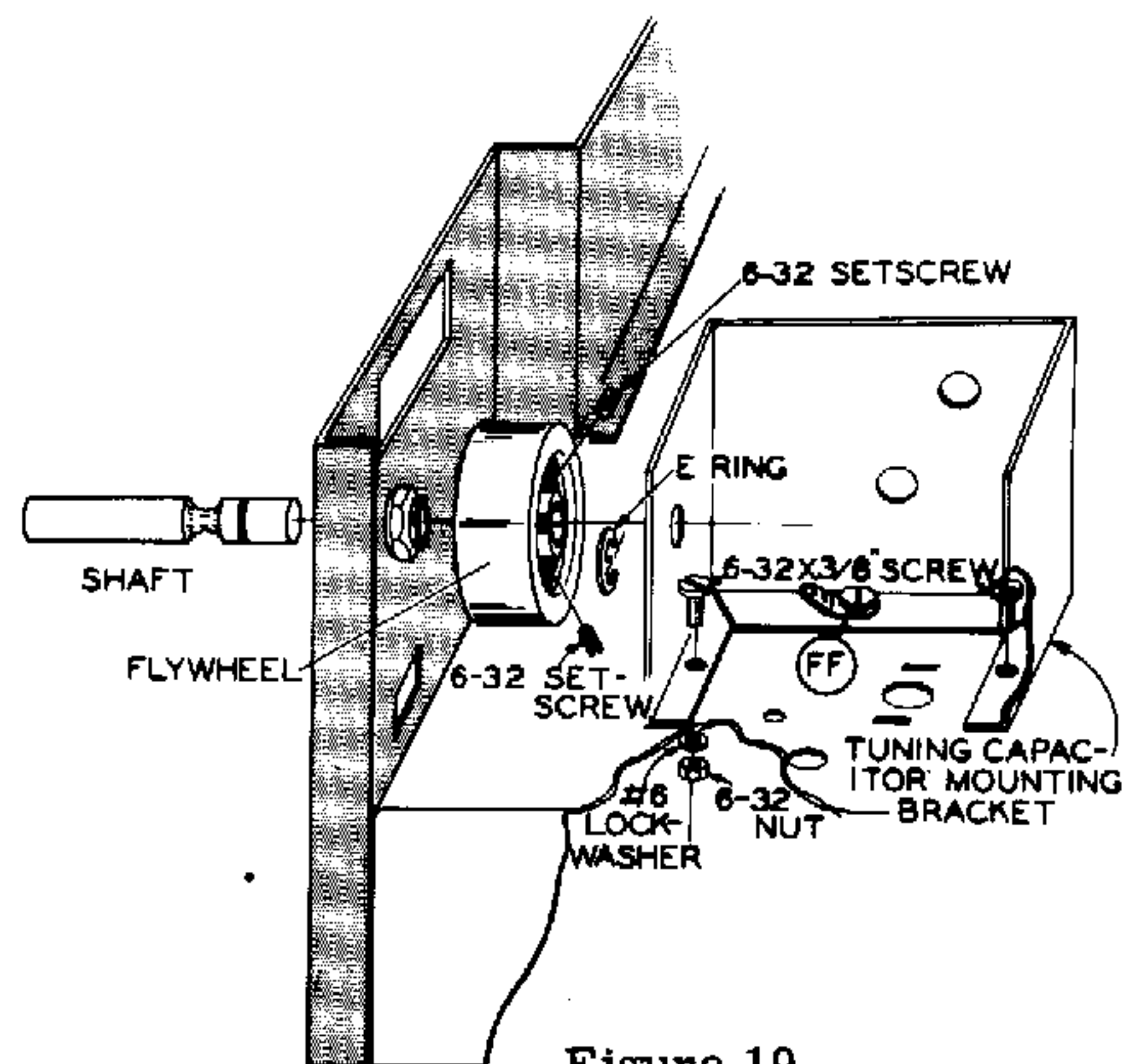

Figure 19

(✓) Hold the end of the MAIN TUNING shaft so that the E ring is against the TUNING capacitor mounting bracket, push the flywheel against the brass bushing, and tighten the two setscrews in the flywheel.

- (✓) Insert the red lead coming from the output transformer into the hole marked RED on the circuit board (S-1).
- (✓) Insert the blue lead coming from the output transformer into the hole marked BLUE on the circuit board (S-1).
- (✓) Position the wire coming through grommet CC as shown in Pictorial 2 and connect it to lug 2 on the speaker (S-1).
- (✓) C23. Locate the large 4-section can type electrolytic capacitor and install it on the circuit board in the position shown. The large lug is called the locating lug and should go through the larger hole in the circuit board first, then the rest of the lugs will line up with their respective holes. Solder all seven lugs.

The lengths of hookup wire needed for the following steps are:

- (/ ) 9-1/2"      ||      ( J ) 4"
- (✓) 5-1/4"      ||      ( J ) 2-1/2" bare
- (✓) Connect a 9-1/2" wire from hole F8 (S-1) to hole F3 (S-1) on the circuit board. Position this wire as shown in Pictorial 2.
- (✓) Connect a 5-1/4" wire from hole F7 (S-1) to hole F6 (S-1) on the circuit board.
- (✓) Connect a 4" wire from hole F5 (S-1) to hole F4 (S-1) on the circuit board.
- ( ) Referring to Pictorial 1, connect a 2-1/2" bare wire from solder lug E (S-1) to lug 1 of control F (S-2).
- ( ) Connect the bare wire coming from the ANT hole on the circuit board to lug 1 on capacitor K (S-1). Now solder the ANT hole (S-1). Be sure this wire does not touch the capacitor frame.

- ( ) Connect the bare wire coming from the OSC hole on the circuit board to lug 1 on capacitor M (S-1). Now solder the OSC hole (S-1). Be sure this wire does not touch the capacitor frame.
- ( ) Referring to Figure 23, mount the line cord and line cord strain relief in hole U. Leave 1-1/2" of wire inside the chassis.

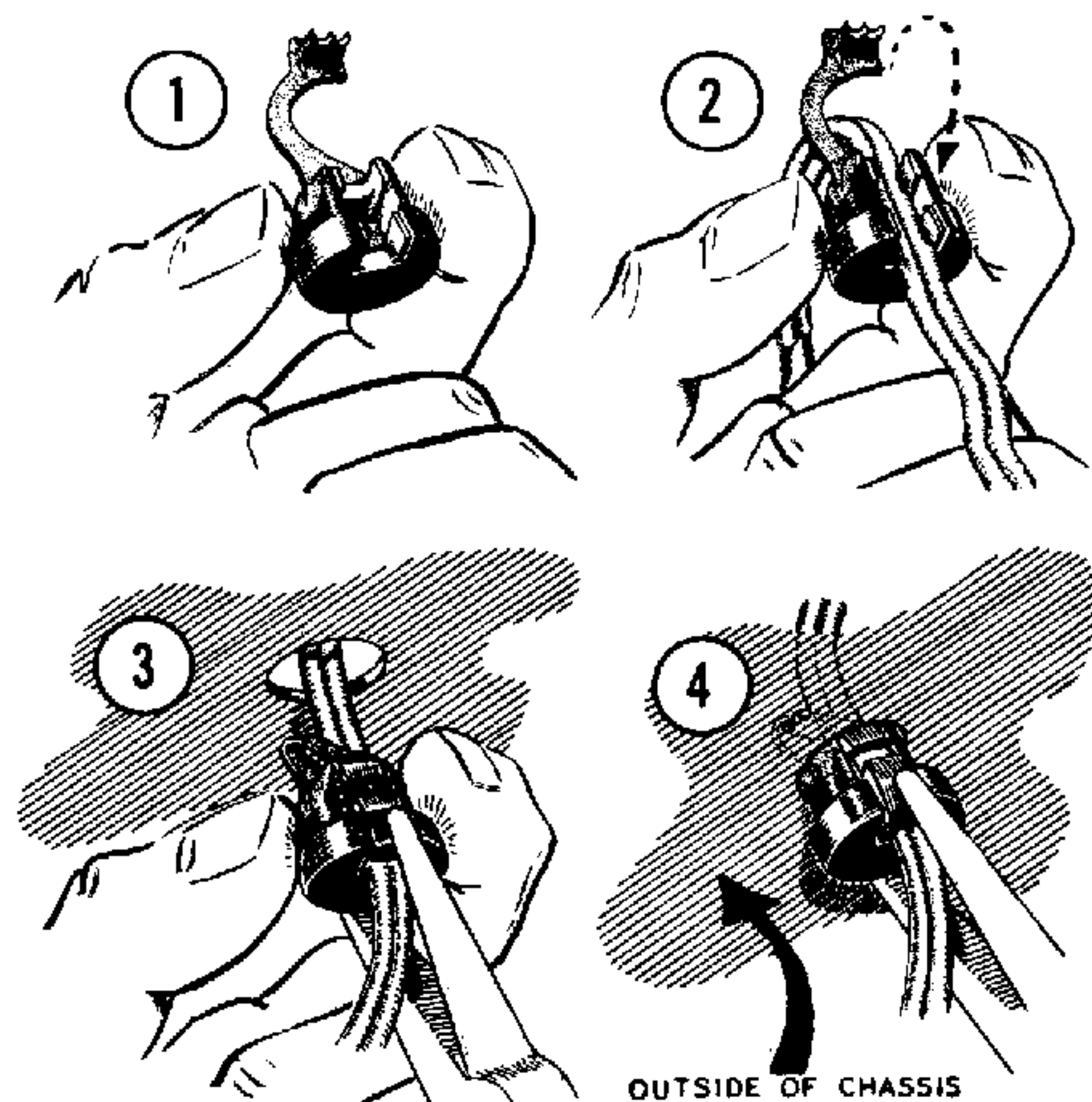

Figure 23

- ( ) Connect either line cord wire to lug 4 (S-2) and the other wire to lug 5 (S-2) of terminal strip S. See Pictorial 1.
- ( ) Any bare wire ends protruding through the top of the circuit board should be cut off flush with the top of the circuit board.

This completes the wiring of the Receiver. Carefully inspect the bottom of the chassis to make sure all the connections have been soldered and that none of the conductors on the circuit board are shorted together with excess foil, or wire clippings.

## INITIAL TEST

Refer to Pictorial 1 (fold-out from Page 6) for the following four steps.

If an ohmmeter is available, it would be well to make the following resistance checks before turning the power on for the first time.

- ( ) Measure the resistance between lug 4 of terminal strip S and the chassis, and from lug 5 of terminal strip S and the chassis. Both of these measurements should be at least 15 megohms.
- ( ) Check the resistance between lug 2 of terminal strip S and the chassis. This measurement should be approximately 20  $\Omega$ .
- ( ) Measure the resistance from lug 4 to lug 5 of terminal strip S. This resistance should be approximately 15  $\Omega$  with the VOLUME control switch on.
- ( ) Measure the resistance from point QM on the circuit board to the chassis. This resistance should be at least 25 K $\Omega$ .

If any of the readings are not as just described, refer to the In Case Of Difficulty section of this manual.

NOTE: When installing the tubes, support the bottom of the circuit board with your finger.

- ( ) Insert all tubes in their proper sockets on the circuit board. The tube type number appears near each tube socket on the circuit board.
- ( ) Turn all the front panel control shafts fully counterclockwise.
- ( ) Install the five small knobs on the shafts. Position the pointers to the counterclockwise front panel marking for each shaft.
- ( ) Install the two large knobs, one on the MAIN TUNING capacitor shaft and the other knob on the BAND SPREAD capacitor shaft.

## TEST AND ADJUSTMENT

- ( ) Plug the line cord plug into an electrical outlet, 105-125 volts, 50/60 cycle AC only.
- ( ) Turn the unit on with the VOLUME control. Check to see that the two pilot lamps light and the tube filaments in the four tubes glow. If any overheating is noticed, turn off the Receiver and refer to the In Case Of Difficulty section.
- ( ) Turn the VOLUME control clockwise and listen for a background noise from the speaker.
- ( ) With the Receiver in Band A and by putting your finger on lug 1 or 2 of the antenna terminal or by connecting a length of wire to lug 1 of the antenna terminal, some broadcast stations may be heard when tuning across the dial.
- ( ) By adjusting the ANT TRIMMER control, the signal may be peaked.
- ( ) Similarly, switch the BAND switch through the remaining three bands, checking for any stations that you may pick up.
- ( ) Turn the Selector Switch to the STBY position. The pilot lamps and filaments should still be on but no stations or background noise should be heard from the speaker.
- ( ) Turn the Selector Switch to the CW position and turn the BFO to its 12 o'clock position.
- ( ) By tuning across the higher bands (B, C, and D), some CW stations may be heard.
- ( ) Peak the signal with the ANT TRIMMER control.
- ( ) Turn the unit off and install tube shields over V2 and V3. Make sure the shield slips over the shield clip on each tube socket.
- ( ) Remove the antenna wire if one was used.

clip with pliers as shown in Figure 21A and then solder the wire to the clip. It may be helpful to wrap a rubber band around the handle of the pliers, as shown, so that both of your hands will be free for soldering.

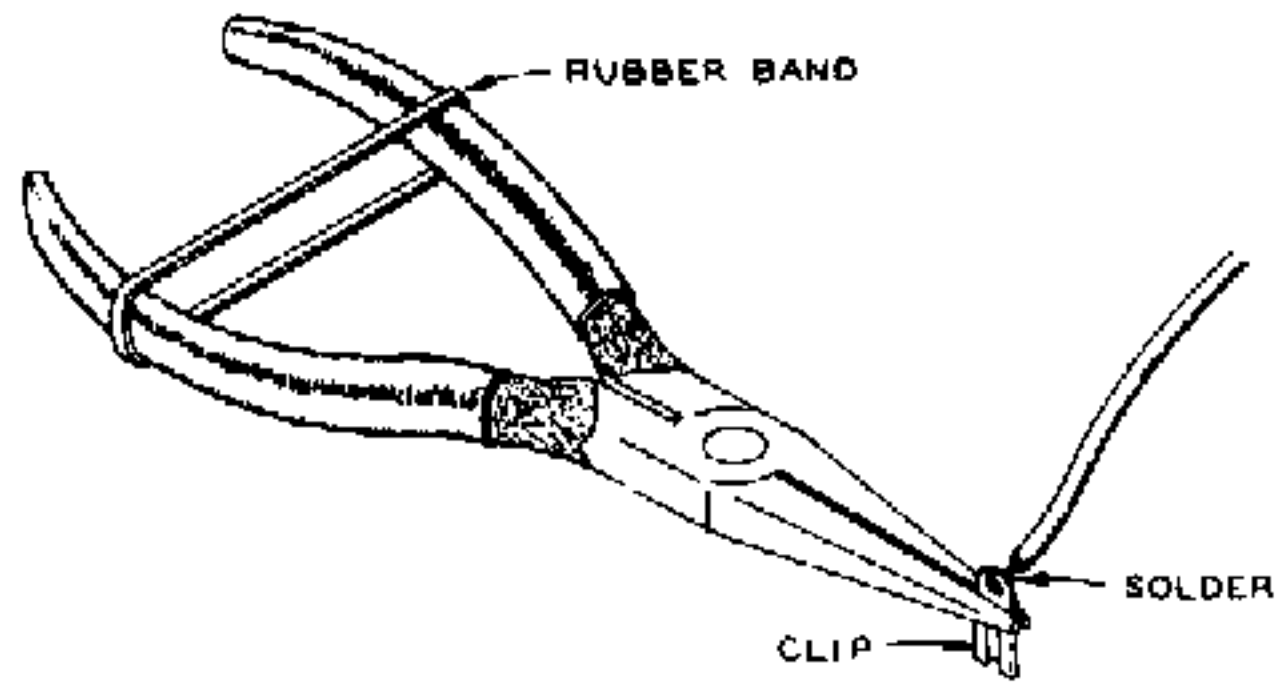

Figure 21A

- ( ) Solder a clip on each wire of the twisted pair coming through grommet AA.
- (✓) After the clips have cooled, connect the white wire clip to the positive (+) lug and the black wire clip to the negative lug on the meter.
- (✓) Referring to Figure 22, mount the angle brackets on the two speaker mounting holes as shown, using two 6-32 x 3/8" screws, #6 lockwashers, and 6-32 nuts.
- (✓) Mount the speaker with the angle brackets on top of the chassis in the position shown in Pictorial 2. Use two 6-32 x 3/16" screws, one #6 lockwasher, and one #6 solder lug underneath the chassis at E. See Pictorial 1.

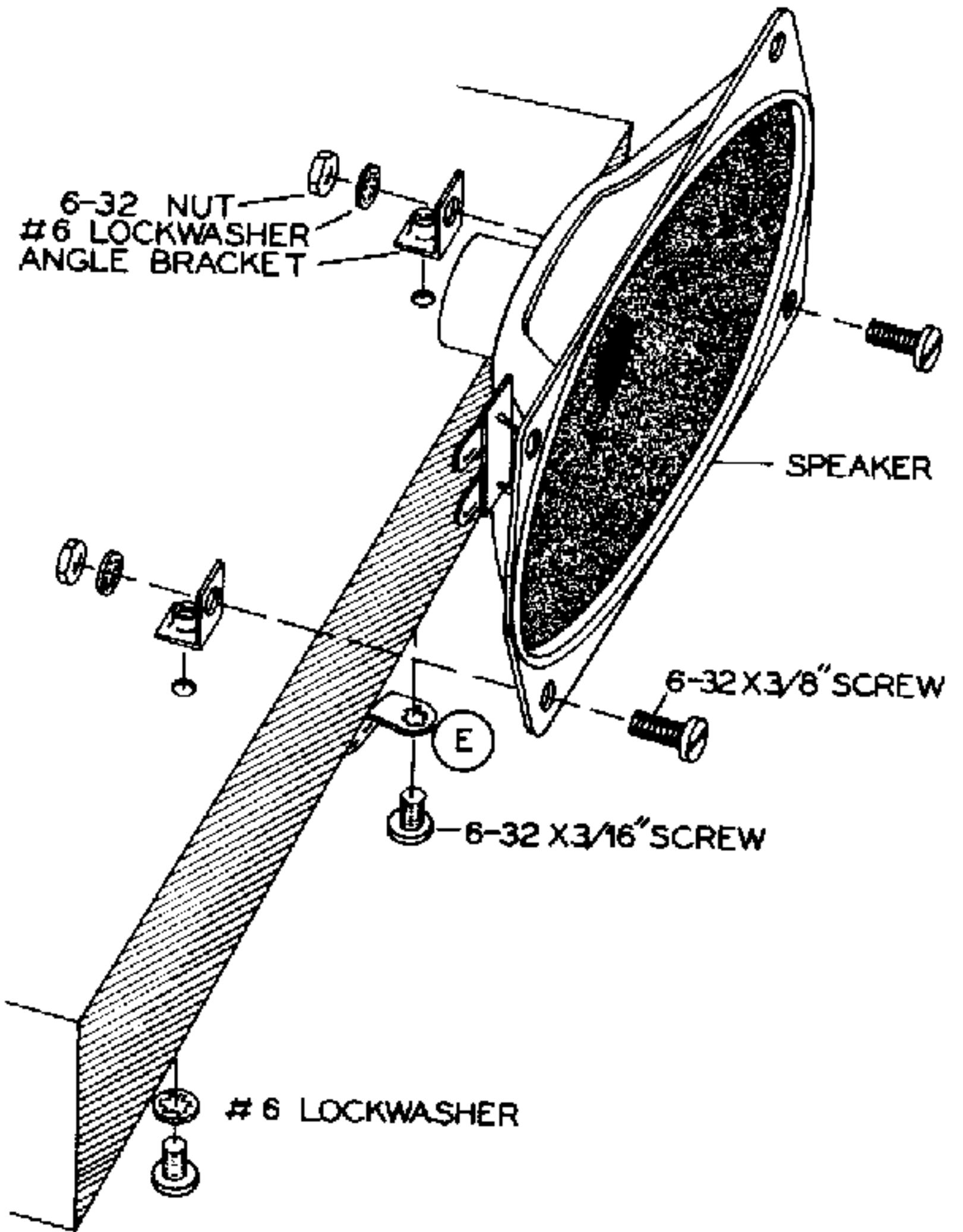

Figure 22

- (✓) Cut the remaining black lead of the output transformer to 1-1/4". Remove 1/4" of insulation from the lead and tin the end.
- (✓) Connect this lead to solder lug DD (NS).
- (✓) Connect a 1-3/4" bare wire from solder lug DD (S-2) to lug 1 on the speaker (S-1).

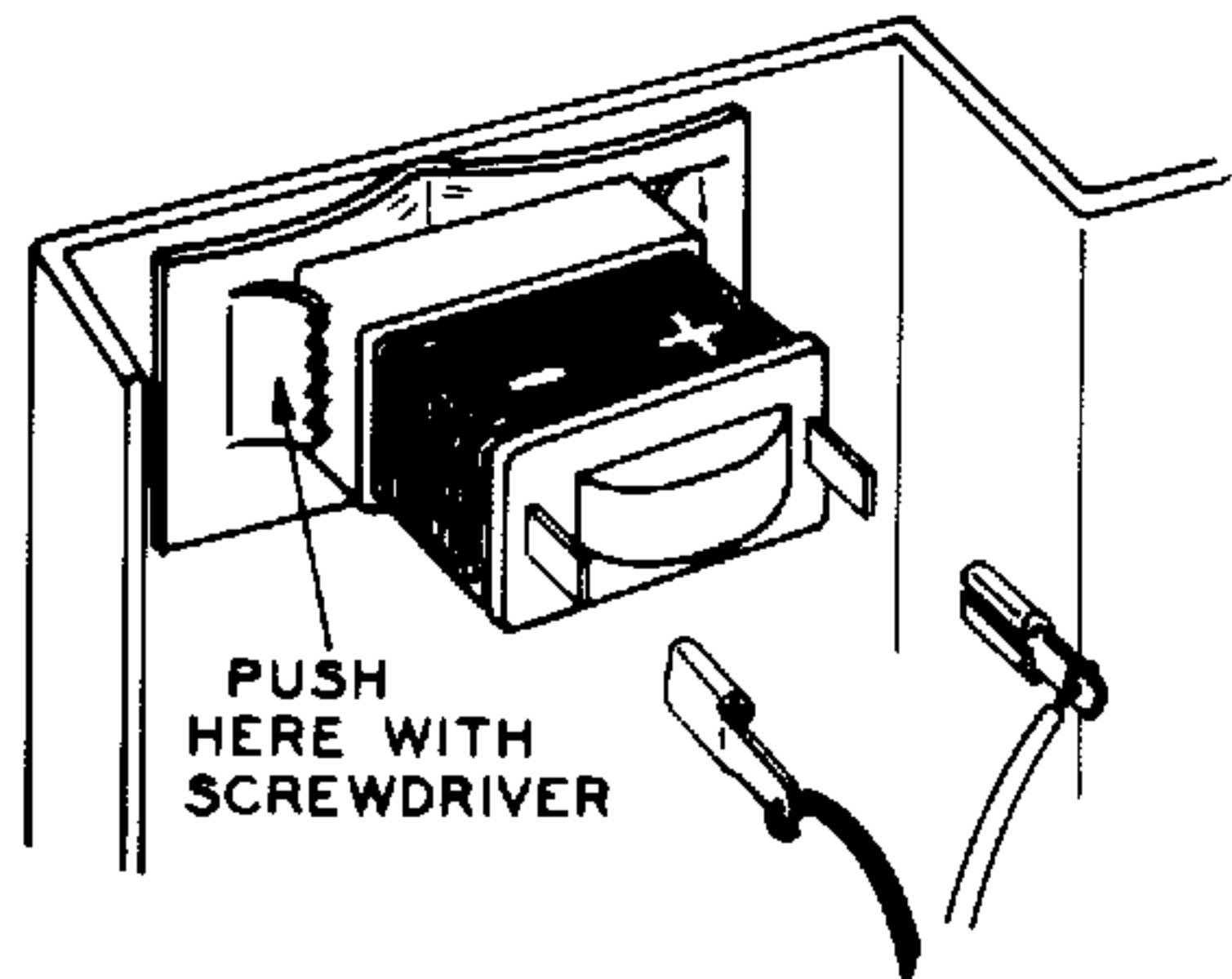
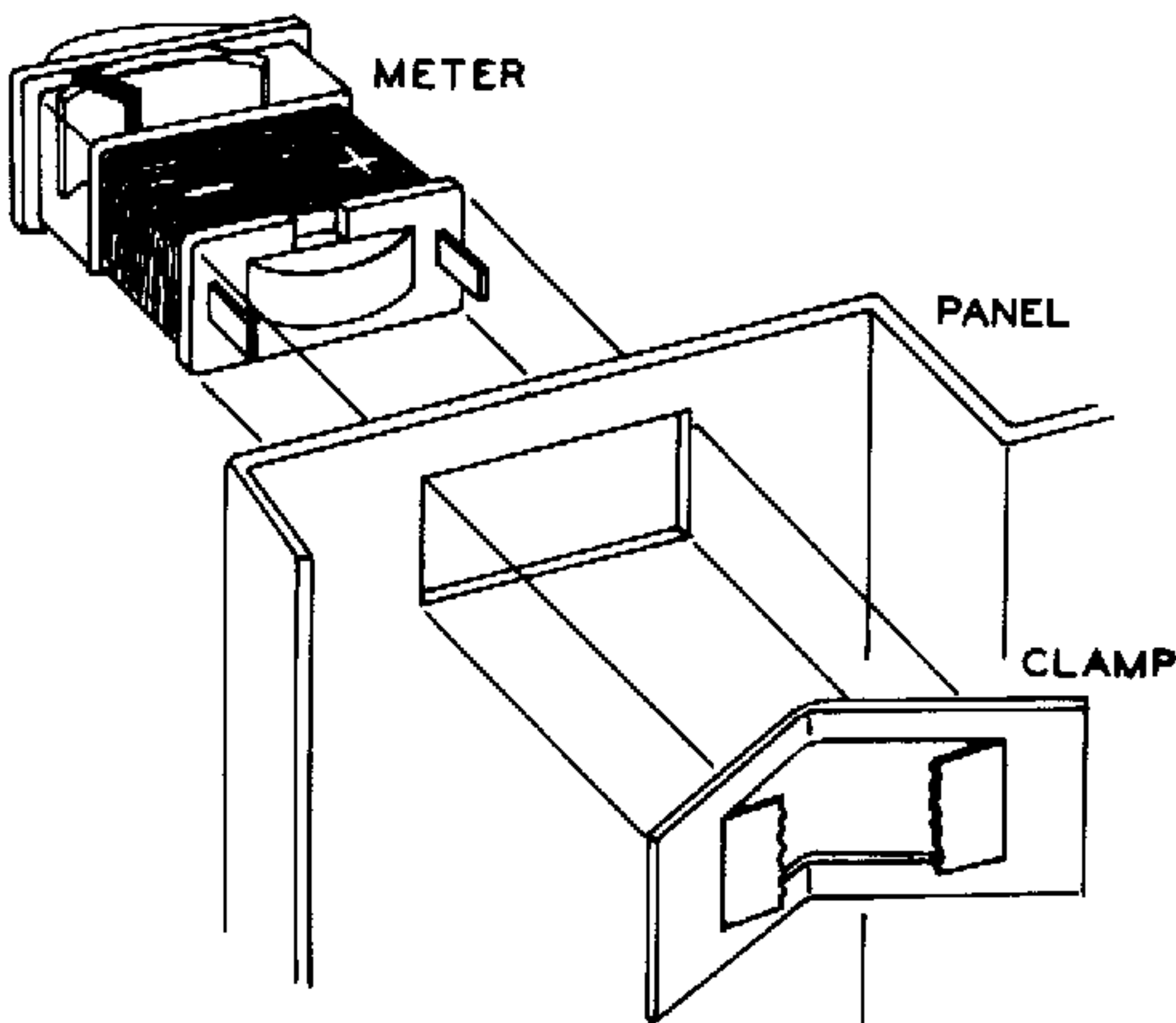

Figure 21

## ADJUSTMENT

Refer to Pictorial 2 (fold-out from Page 33) for the following steps.

- ( ) Turn the Receiver on and wait approximately one minute for the tubes to warm up.
- ( ) If the pointer on the meter does not rest at the left end of the arrow with no signal coming in, adjust the meter zero control R13. This control lies behind the meter and may be adjusted from the top of the chassis with a screwdriver. Adjust the control so that the meter pointer rests at the left end of the meter arrow.

Refer to Pictorial 2 for the following steps.

- ( ) With a small screwdriver, turn C8A and C8D clockwise until they are just snug.
- ( ) Turn C8A 1 turn counterclockwise.
- ( ) Turn C8D 1 turn counterclockwise.

This completes the adjustment. The rest of the coils and IF transformers have been pre-set at the factory and should not require any further adjustment. However, if an RF signal generator and a VTVM are available, a complete alignment procedure is provided on Page 36. If alignment with instruments is not anticipated at this time, refer to the next section of the manual for final assembly of the Receiver.

## FINAL ASSEMBLY

- ( ) Referring to Figure 24, install the two large tapered feet in the holes toward the front edge of the bottom plate. Use two 6-32 x 3/8" screws, #6 lockwashers, and 6-32 nuts.
- ( ) Similarly, install the two small feet in the holes toward the rear of the bottom plate, using two 6-32 x 3/8" screws, #6 lockwashers, and 6-32 nuts.
- ( ) Install the bottom plate to the chassis, using four #6 sheet metal screws. Make sure the two large tapered feet are toward the front of the chassis.
- ( ) Referring to Figure 25, install the cabinet over the top of the chassis. Secure the cabinet to the chassis, using four 6-32 x 1/4" black screws.

- ( ) Mount the rear cover on the rear of the cabinet, using six #6 sheet metal screws.

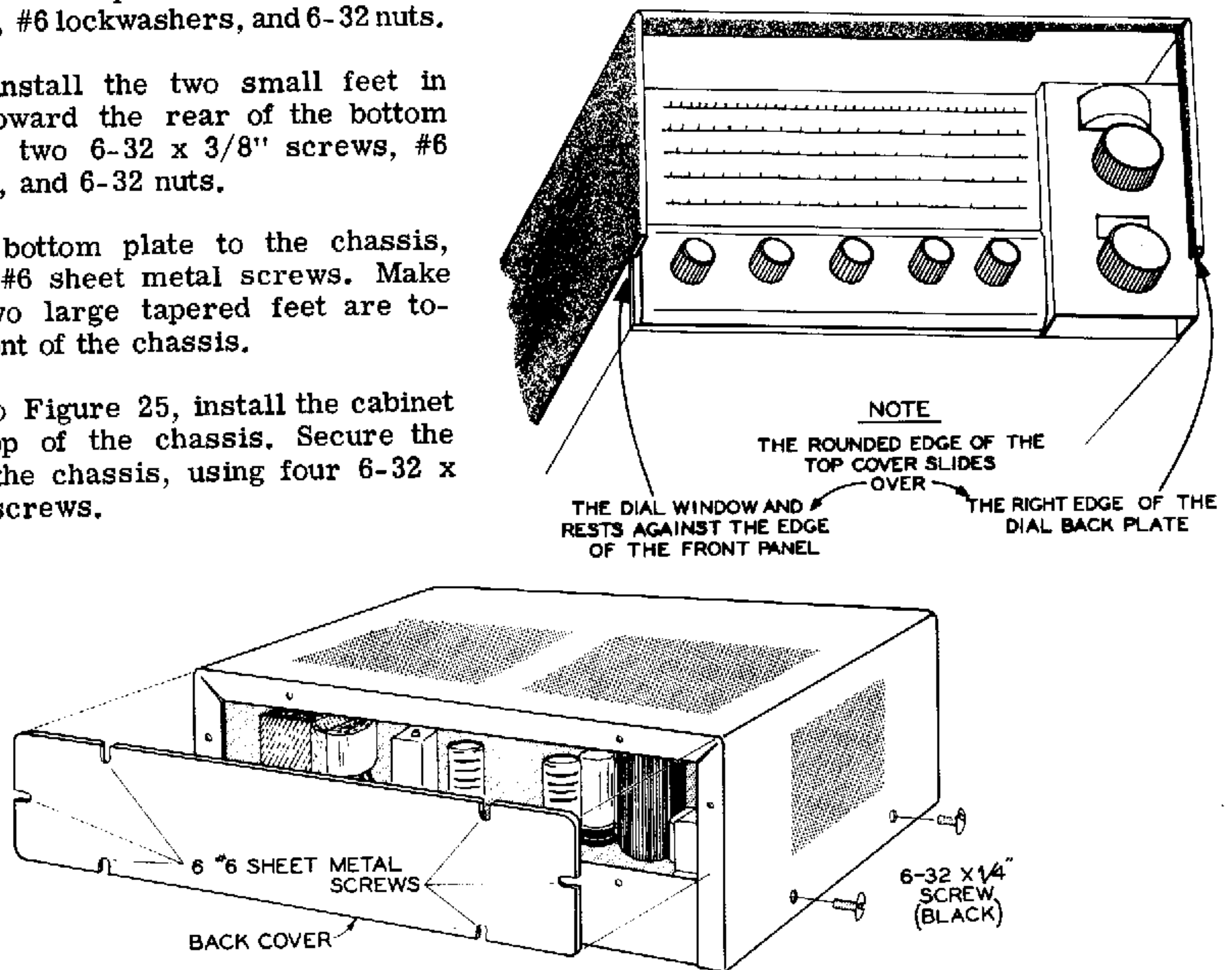

Figure 25

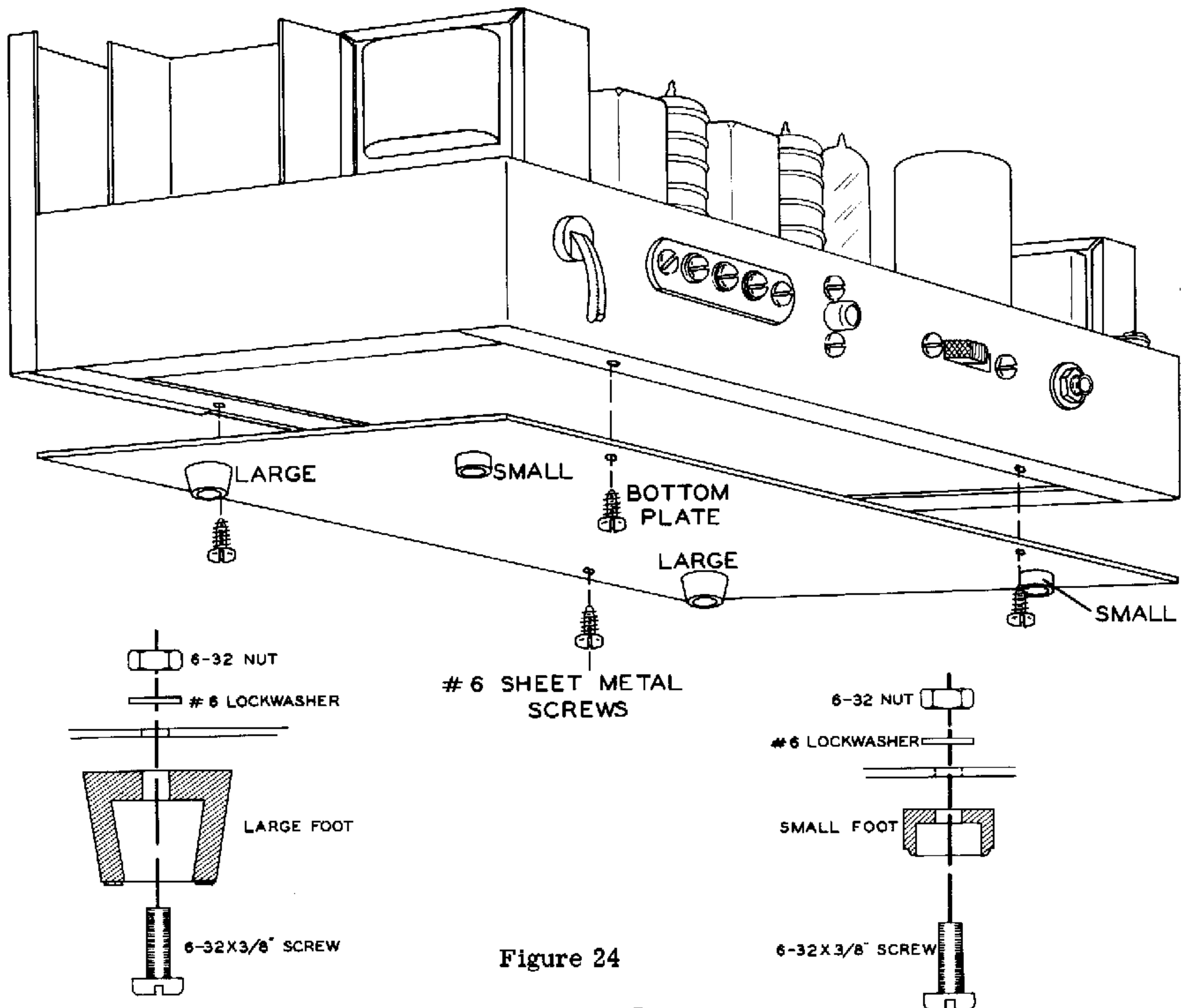

Figure 24

## OPERATION

### CONTROLS

**VOLUME CONTROL** - Turns the receiver on or off and varies the volume from the speaker or headphone.

**BFO CONTROL** - Turns the BFO on or off and varies the tone of the CW signal. Also useful when tuning weak AM stations.

**SELECTOR SWITCH** - Selects AM, STBY, or CW mode of reception. In the AM position, the AVC voltage is on; in CW position, the AVC voltage is off.

**BAND SWITCH** - Selects one of four bands: A, B, C, and D.

**ANTENNA TRIMMER** - Peaks the signal at the frequency being received.

**BAND SPREAD** - Fine tunes the MAIN TUNING capacitor to help separate the incoming signal from other signals near the same frequency.

**TUNING** - Tunes in the desired station.

### AM OPERATION

The BFO control should be in the OFF position. Turn the Selector Switch to AM and advance the VOLUME control for sufficient volume. Set the BAND switch to the desired band and tune in a station with the MAIN TUNING control.

Turn the BAND SPREAD control until the desired station is centered (that is, for the clearest reception). Peak the signal, using the ANTenna TRIMMER.

When listening to weak stations, turn the BFO ON and slowly adjust this control for the loudest and clearest reception.

### CW-SSB OPERATION

Turn the BFO control 3/4 turn clockwise. Turn the Selector Switch to CW and set the BAND switch to one of the shortwave bands, B, C, or D.

With the MAIN TUNING control, tune in a CW station. Adjust the BFO control as follows: Turn the control fully clockwise and then slowly counterclockwise until the clearest tone is produced. The frequency of this tone may be varied either with the MAIN TUNING or the BAND SPREAD capacitor. Some experimentation will be necessary to find the best position for the BFO control.

When tuning SSB (single side band) signals, tune to the SSB station and then alternate between the BAND SPREAD and BFO controls for the clearest reception.

## ANTENNA INSTALLATION

The Receiver must have an antenna for proper reception. A length of wire 10 feet long will probably give good reception on the broadcast band. For shortwave listening, a longer, outdoor antenna should be used.

For general broadcast and shortwave listening, a long-wire outside antenna is suggested. A typical long-wire antenna installation is shown in Figure 26. The length of the antenna wire may be from 50 to 100 feet long. The lead-in wire should be attached and soldered to one end of the antenna. The other end of the lead-in wire is connected to lug 1 on the antenna terminal strip of the Receiver.

Generally, the higher the antenna the better the reception. A tree or pole may be used as one support and your house as the other support. Insulators must be used at each end of the antenna to separate the antenna wire from the support wire.

Lug 3 of the antenna terminal strip on the Receiver should be grounded to a water pipe or to a 6 to 8 feet long ground rod driven into the earth.

A dipole or folded dipole antenna may be used for optimum reception on the shortwave band. This type of antenna is directional and is designed to receive a narrow band of the shortwave frequencies. It is suggested you check an ARRL Handbook or an Antenna Handbook for the proper dipole or folded dipole antenna length needed for the shortwave frequencies you intend to listen to.

To connect a dipole antenna to the Receiver, connect a short wire between lugs 2 and 3 on the antenna terminal strip, and connect the two lead-in wires from the dipole antenna to lugs 1 and 2 on the antenna terminal strip of the Receiver. See Figure 26.

To connect a folded dipole antenna to the Receiver, connect the two lead-in wires from the antenna to lugs 2 and 3 on the antenna terminal strip; no wire is used between lugs 2 and 3. See Figure 26.

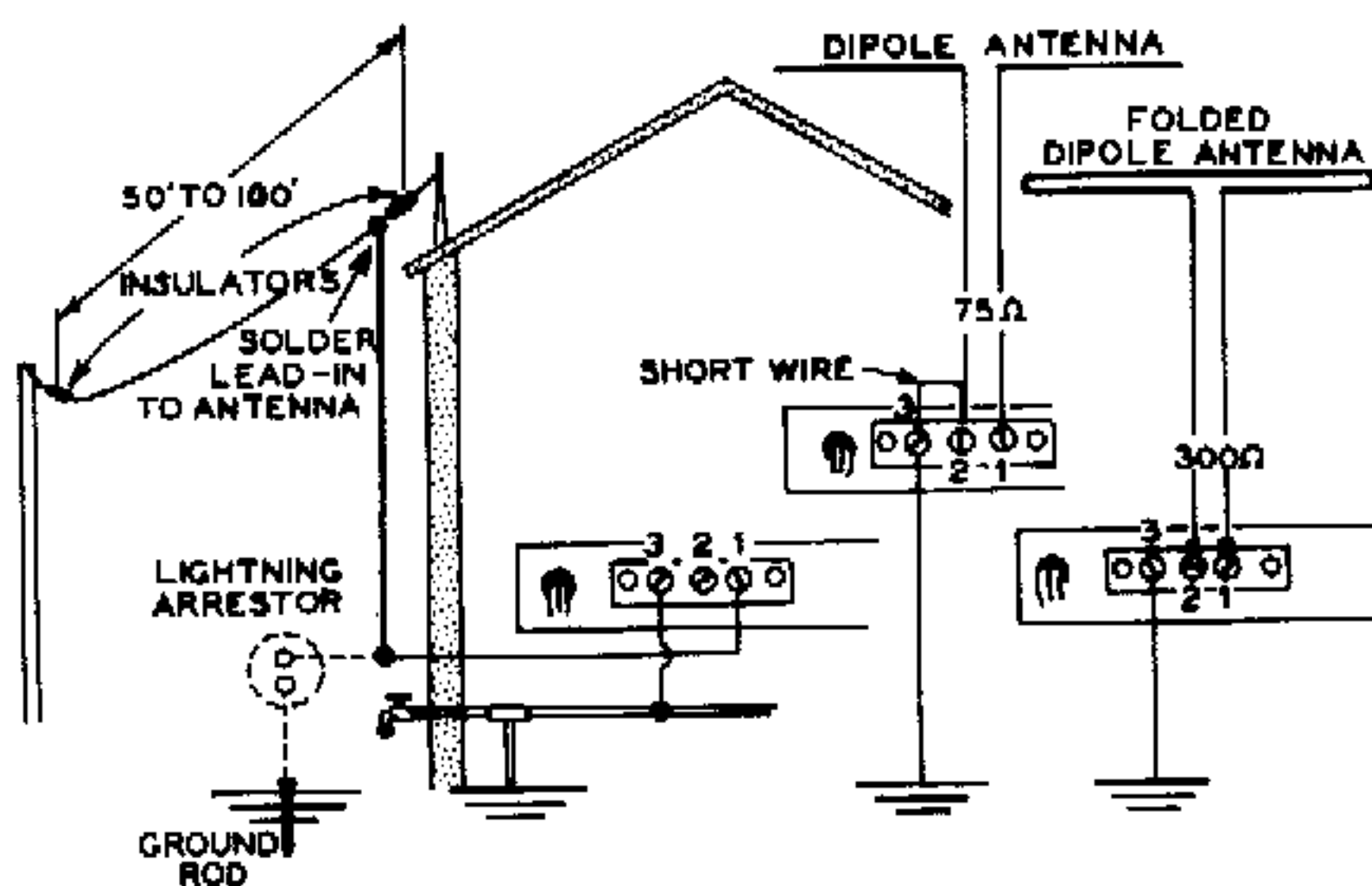

Figure 26

**RECEPTION GUIDE**

<u>BAND</u>	<u>FREQUENCY</u>	<u>TIME</u>	<u>ZONE</u>
80 M	3.5 mc	Morning	Local (Amateur)
49 M	6 mc	Evening	Latin America and Europe
41 M	7 mc	Evening	Europe
40 M	7 mc	Late afternoon, Evening	Europe
40 M	7 mc	Morning	United States (Amateur)
31 M	9 mc	Morning	Asia and Australia
31 M	9 mc	Afternoon	Europe and Africa
31 M	9 mc	Evening	Europe and Latin America
25 M	11 mc	Morning	Asia and Australia
25 M	11 mc	Evening	Latin America
20 M	14 mc	Late morning, Afternoon	United States, Foreign, (Amateur)
19 M	15 mc	Late morning, Afternoon	Europe and North America
19 M	15 mc	Evening	North and Latin America
16 M	17 mc	Afternoon	Europe
	17 mc	All day	United States
	17 mc	Evening	South America
13 M	20 mc	Afternoon	Europe
	20 mc	All day	United States
	20 mc	Evening	South America
11 M	27 mc	All day	Local (Citizen's Band)
10 M	28 mc	Morning	Europe
	28 mc	All day Evening	Central America, United States (Amateur), Asia

These reception conditions prevail in the spring and fall of the year. They are also subject to varying atmospheric conditions, sun spot activities, and to some extent, weather conditions. In the winter, reception generally will be best on the lower frequency bands. In summer, reception will be better on higher frequency bands.

**IN CASE OF DIFFICULTY**

1. Recheck the wiring. Trace each lead in colored pencil on the Pictorial as it is checked. It is frequently helpful to have a friend check your work. Someone who is not familiar with the unit may notice something consistently overlooked by the constructor.
2. It is interesting to note that about 90% of the kits that are returned for repair, do not function properly due to poor connections and soldering. Therefore, many troubles can be eliminated by reheating all connections to make sure that they are soldered as described in the Proper Soldering Techniques section of this manual.
3. Check to be sure that all tubes are in their proper locations. Make sure that all tubes light up properly.
4. Check the tubes with a tube tester or by substitution of tubes of the same types and known to be good.

5. Check the values of the component parts. Be sure that the proper part has been wired into the circuit, as shown in the pictorial diagrams and as called out in the wiring instructions.
6. Check for bits of solder, wire ends or other foreign matter which may be lodged in the wiring beneath the chassis.
7. If, after careful checks, the trouble is still not located and a voltmeter is available, check voltage readings against those found on the Schematic Diagram. NOTE: All voltage readings were taken with an 11 megohm input vacuum tube voltmeter. Voltages may vary as much as 10% due to line voltage variations.
8. A review of the Circuit Description will prove helpful in indicating where to look for trouble.

SPECIFIC PROBLEMS	
PROBLEM	CHECK
Filaments do not light.	<ol style="list-style-type: none"> <li>1. Check filament wiring on top of the circuit board against Pictorial 2 on Page 33.</li> <li>2. Open tube filament - with an ohmmeter, check for continuity between pins 3 and 4 on all four tubes.</li> <li>3. Check wiring of terminal strip J against Pictorial 1 (fold-out from Page 6).</li> <li>4. Check power transformer wiring against Pictorial 1 (fold-out from Page 6).</li> </ol>
Filaments light, but no sound with VOLUME control turned fully clockwise.	<ol style="list-style-type: none"> <li>1. Make sure the Selector Switch is not in STBY position.</li> <li>2. Check wiring between the VOLUME control and the circuit board against Pictorial 1 (fold-out from Page 6).</li> </ol> <p>CAUTION: When making the following checks, do not touch the chassis with your other hand.</p> <ol style="list-style-type: none"> <li>3. Turn the Receiver on and place a small screwdriver on lug 5 of tube socket V4, then touch your finger to the metal portion of the screwdriver; a low pitched hum should be audible.</li> <li>4. Now place the screwdriver on lug 1 of tube socket V3. Again touch your finger to the metal portion, this time the hum should be louder.</li> </ol> <p>If no hum is present check the circuit board components of tubes V3 and V4 and the wiring to the speaker.</p>

PROBLEM	CHECK
<p>Audio present - no signals can be heard.</p>	<p>CAUTION: When making the following tests, do not touch the chassis with your other hand.</p> <ol style="list-style-type: none"> <li>Place a small screwdriver on lug 1 of tube socket V2 and with your finger, touch the metal portion of the screwdriver. A low pitched hum should be heard.  If no hum is present, check the circuit board components around tube socket V2.</li> <li>Similarly, make the screwdriver test on lug 7 of tube socket V1. The hum should be louder.  If no hum is present or if the hum level does not increase, check the components on the circuit around tube socket V1.</li> <li>With an ohmmeter, check for continuity from lug 1 on the antenna terminal to ground. The following resistance reading should be obtained for the BAND switch positions.   <div style="text-align: right;">                     Band A - 40 Ω                      Band B - 1 Ω                      Band C - 1 Ω                      Band D - .4 Ω                 </div> </li> </ol>
<p>High hum level.</p>	<ol style="list-style-type: none"> <li>Reposition the two twisted pairs (coming from the AVC and AUDIO holes on the circuit board) at least 1-1/2" above the circuit board, along the side of the chassis, and above the other two twisted pairs of wires running under control F.</li> </ol>

## ALIGNMENT WITH INSTRUMENTS

Alignment must be performed without the bottom plate installed. Before attempting the alignment procedure, operate the Receiver for a minimum of 15 minutes to allow the tubes and components to stabilize.

A plastic alignment tool is provided to align the coils. With slight modification this tool will also be useful for aligning the IF transformers.

( ) Referring to Figure 27, cut off 1/4" from one end of the alignment tool.

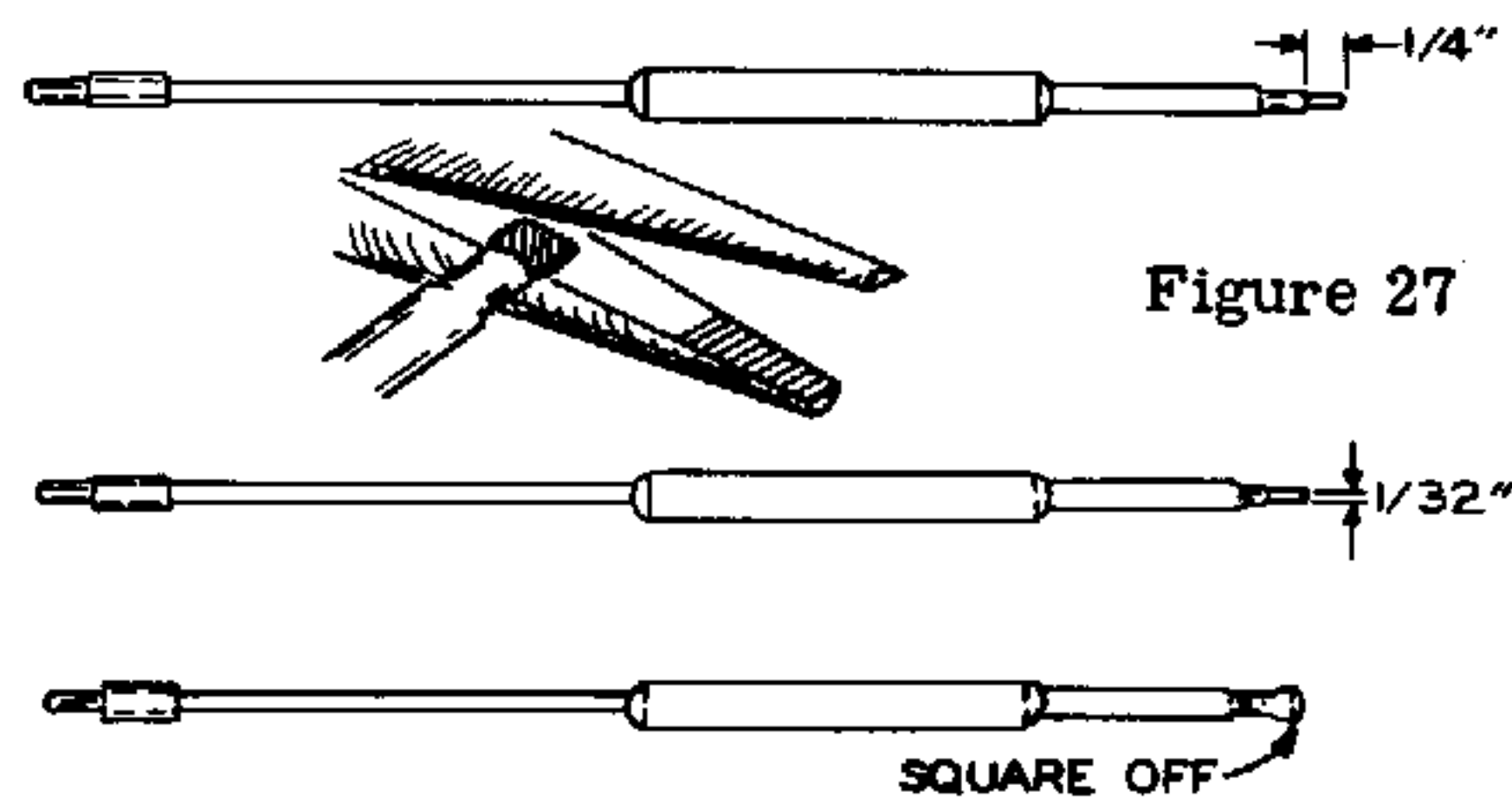

( ) At the same end of this alignment tool, flatten the tip with pliers until it is approximately 1/32" thick. See Figure 27. Be sure the flattened end is squared off as shown.

NOTE: The flatted end of the alignment tool should fit the slots in the IF transformer slugs. The other end of the alignment tool is used to align the coils.

Preset trimmers A, B, and C to the settings shown in Figure 17 on Page 24.

Refer to Figure 28 (fold-out from Page 34) for the alignment positions.

Set the BAND switch to Band B and set the dial pointer to 1.5 mc. Connect the common VTVM lead to the chassis and the DC test lead to lug 3 on the VOLUME control. Set the VTVM to read DC- and the range switch to one of the higher ranges.

Connect the common signal generator lead to the chassis and the positive lead to lug 1 on the antenna terminal strip on the rear of the Receiver. Set the signal generator to 455 kc, unmodulated, and reduce the output until a readable voltage is obtained on the lowest possible VTVM range.

During alignment, reduce the signal generator output as the VTVM readings become higher. Always use the lowest signal generator output possible to still have a readable voltage on the lowest VTVM range.

Proceed with alignment, using the Alignment Chart.

### ALIGNMENT CHART

<u>TUNE SIGNAL GENERATOR TO:</u>	<u>SET BAND SWITCH TO:</u>	<u>SET TUNER DIAL TO:</u>	<u>ADJUST FOR MAXIMUM METER READING</u>
1. 455 kc	B	1.5 mc	IF-1 top and bottom
2. 455 kc	B	1.5 mc	IF-2 top and bottom
3. Repeat steps 1 and 2.			
4. Rotate the BAND SPREAD capacitor fully clockwise.			
5. Adjust the ANT TRIMMER capacitor so the plates are 50% meshed.			
6. 30 mc	D	30 mc	C8D
7. Adjust the ANT TRIMMER capacitor so the plates are fully meshed.			
8. 10 mc	D	10 mc	L5
9. 10 mc	D	10 mc	C8A
10. Tune the Receiver to 10,910 mc and check for the image frequency. If the image frequency does not appear at this point, repeat steps 5 through 9, being careful to align to the correct frequency. The image frequency is 910 kc below the signal frequency on Bands A, B, and C.			
11. 4 mc	C	4 mc	L6 and L2
12. 10 mc	C	10 mc	C4
13. 4 mc	C	4 mc	L6
14. 1.5 mc	B	1.5 mc	L7 and L3
15. 4 mc	B	4 mc	C5
16. 1.5 mc	B	1.5 mc	L7

<u>TUNE SIGNAL GENERATOR TO:</u>	<u>SET BAND SWITCH TO:</u>	<u>SET TUNER DIAL TO:</u>	<u>ADJUST FOR MAXIMUM METER READING</u>
17. 550 kc	A	550 kc	L8
18. 1.5 mc	A	1.5 mc	C6
19. Adjust the ANT TRIMMER so the plates are 50% meshed.			
20. 1.0 mc	A	1.0 mc	L4
21. 550 kc	A	550 kc	L8

NOTE: L1 has been preset - DO NOT ADJUST.

## SERVICE INFORMATION

### SERVICE

If, after applying the information contained in this manual and your best efforts, you are still unable to obtain proper performance, it is suggested that you take advantage of the technical facilities which the Heath Company makes available to its customers.

The Technical Consultation Department is maintained for your benefit. This service is available to you at no charge. Its primary purpose is to provide assistance for those who encounter difficulty in the construction, operation or maintenance of HEATHKIT equipment. It is not intended, and is not equipped to function as a general source of technical information involving kit modifications nor anything other than the normal and specified performance of HEATHKIT equipment.

Although the Technical Consultants are familiar with all details of this kit, the effectiveness of their advice will depend entirely upon the amount and the accuracy of the information furnished by you. In a sense, YOU MUST QUALIFY for GOOD technical advice by helping the consultants to help you. Please use this outline:

1. Before writing, fully investigate each of the hints and suggestions listed in this manual under In Case Of Difficulty. Possibly it will not be necessary to write.

2. When writing, clearly describe the nature of the trouble and mention all associated equipment. Specifically report operating procedures, switch positions, connections to other units and anything else that might help to isolate the cause of trouble.
3. Report fully on the results obtained when testing the unit initially and when following the suggestions under In Case Of Difficulty. Be as specific as possible and include voltage readings if test equipment is available.
4. Identify the kit model number and date of purchase if available. Also mention the date of the kit assembly manual. (Date at bottom of Page 1.)
5. Print or type your name and address, preferably in two places on the letter.

With the preceding information, the consultant will know exactly what kit you have, what you would like it to do for you and the difficulty you wish to correct. The date of purchase tells him whether or not engineering changes have been made since it was shipped to you. He will know what you have done in an effort to locate the cause of trouble and, thereby, avoid repetitious suggestions. In short, he will devote full time to the problem at hand, and through his familiarity with the kit, plus your accurate report, he will be able to give you a complete and helpful answer. If replacement parts are re-

quired, they will be shipped to you, subject to the terms of the Warranty.

The Factory Service facilities are also available to you, in case you are not familiar enough with electronics to provide our consultants with sufficient information on which to base a diagnosis of your difficulty, or in the event that you prefer to have the difficulty corrected in this manner. You may return the completed instrument to the Heath Company for inspection and necessary repairs and adjustments. You will be charged a minimal service fee, plus the price of any additional parts or material required. However, if the completed kit is returned within the Warranty period, parts charges will be governed by the terms of the Warranty. State the date of purchase, if possible.

Local Service by Authorized HEATHKIT Service Centers is also available in some areas and often will be your fastest, most efficient method of obtaining service for your HEATHKIT equipment. Although you may find charges for local service somewhat higher than for factory service, the amount of increase is usually offset by the transportation charge you would pay if you elected to return your kit to the Heath Company.

HEATHKIT Service Centers will honor the regular 90 day HEATHKIT Parts Warranty on all kits, whether purchased through a dealer or directly from Heath Company; however, it will be necessary that you verify the purchase date of your kit.

Under the conditions specified in the Warranty, replacement parts are supplied without charge; however, if the Service Center assists you in locating a defective part (or parts) in your kit, or installs a replacement part for you, you may be charged for this service.

HEATHKIT equipment purchased locally and returned to Heath Company for service must be accompanied by your copy of the dated sales receipt from your authorized HEATHKIT dealer in order to be eligible for parts replacement under the terms of the Warranty.

**THIS SERVICE POLICY APPLIES ONLY TO COMPLETED EQUIPMENT CONSTRUCTED IN ACCORDANCE WITH THE INSTRUCTIONS AS STATED IN THE MANUAL.** Equipment that has

been modified in design will not be accepted for repair. If there is evidence of acid core solder or paste fluxes, the equipment will be returned NOT repaired.

For information regarding modification of HEATHKIT equipment for special applications, it is suggested that you refer to any one or more of the many publications that are available on all phases of electronics. They can be obtained at or through your local library, as well as at most electronic equipment stores. Although the Heath Company sincerely welcomes all comments and suggestions, it would be impossible to design, test, evaluate and assume responsibility for proposed circuit changes for special purposes. Therefore, such modifications must be made at the discretion of the kit builder, using information available from sources other than the Heath Company.

## REPLACEMENTS

Material supplied with HEATHKIT products has been carefully selected to meet design requirements and ordinarily will fulfill its function without difficulty. Occasionally improper instrument operation can be traced to a faulty component. Should inspection reveal the necessity for replacement, write to the Heath Company and supply all of the following information.

- A. Thoroughly identify the part in question by using the part number and description found in the manual Parts List.
- B. Identify the type and model number of kit in which it is used.
- C. Mention date of purchase.
- D. Describe the nature of defect or reason for requesting replacement.

The Heath Company will promptly supply the necessary replacement. **PLEASE DO NOT RETURN THE ORIGINAL COMPONENT UNTIL SPECIFICALLY REQUESTED TO DO SO.** Do not dismantle the component in question as this will void the guarantee. This replacement policy does not cover the free replacement of parts that may have been broken or damaged through carelessness on the part of the kit builder.



## SHIPPING INSTRUCTIONS

In the event that your instrument must be returned for service, these instructions should be carefully followed.

Include all the tubes and the cabinet when returning the instrument for service.

**ATTACH A TAG TO THE EQUIPMENT BEARING YOUR NAME, COMPLETE ADDRESS, DATE OF PURCHASE, AND A BRIEF DESCRIPTION OF THE DIFFICULTY ENCOUNTERED.** Wrap the equipment in heavy paper, exercising care to prevent damage. Place the wrapped equipment in a stout carton of such size that at least three inches of shredded paper, excelsior, or other resilient packing material can be placed be-

tween all sides of the wrapped equipment and the carton. Close and seal the carton with gummed paper tape, or alternately, tie securely with stout cord. Clearly print the address on the carton as follows:

To: HEATH COMPANY  
Benton Harbor, Michigan

Include your name and return address on the outside of the carton. Preferably affix one or more "Fragile" or "Handle With Care" labels to the carton, or otherwise so mark with a crayon of bright color. Ship by insured parcel post or prepaid express; note that a carrier cannot be held responsible for damage in transit if, in HIS OPINION, the article is inadequately packed for shipment.

## WARRANTY

Heath Company warrants that for a period of three months from the date of shipment, all Heathkit parts shall be free of defects in materials and workmanship under normal use and service and that in fulfillment of any breach of such warranty, Heath Company shall replace such defective parts upon the return of the same to its factory. The foregoing warranty shall apply only to the original buyer, and is and shall be in lieu of all other warranties, whether express or implied and of all other obligations or liabilities on the part of Heath Company and in no event shall Heath Company be liable for any anticipated profits, consequential damages, loss of time or other losses incurred by the buyer in connection with the purchase, assembly or operation of Heathkits or components thereof. No replacement shall be made of parts damaged by the buyer in the course of handling or assembling Heathkit equipment.

NOTE: The foregoing warranty is completely void and we will not replace, repair or service instruments or parts thereof in which acid core solder or paste fluxes have been used.

HEATH COMPANY

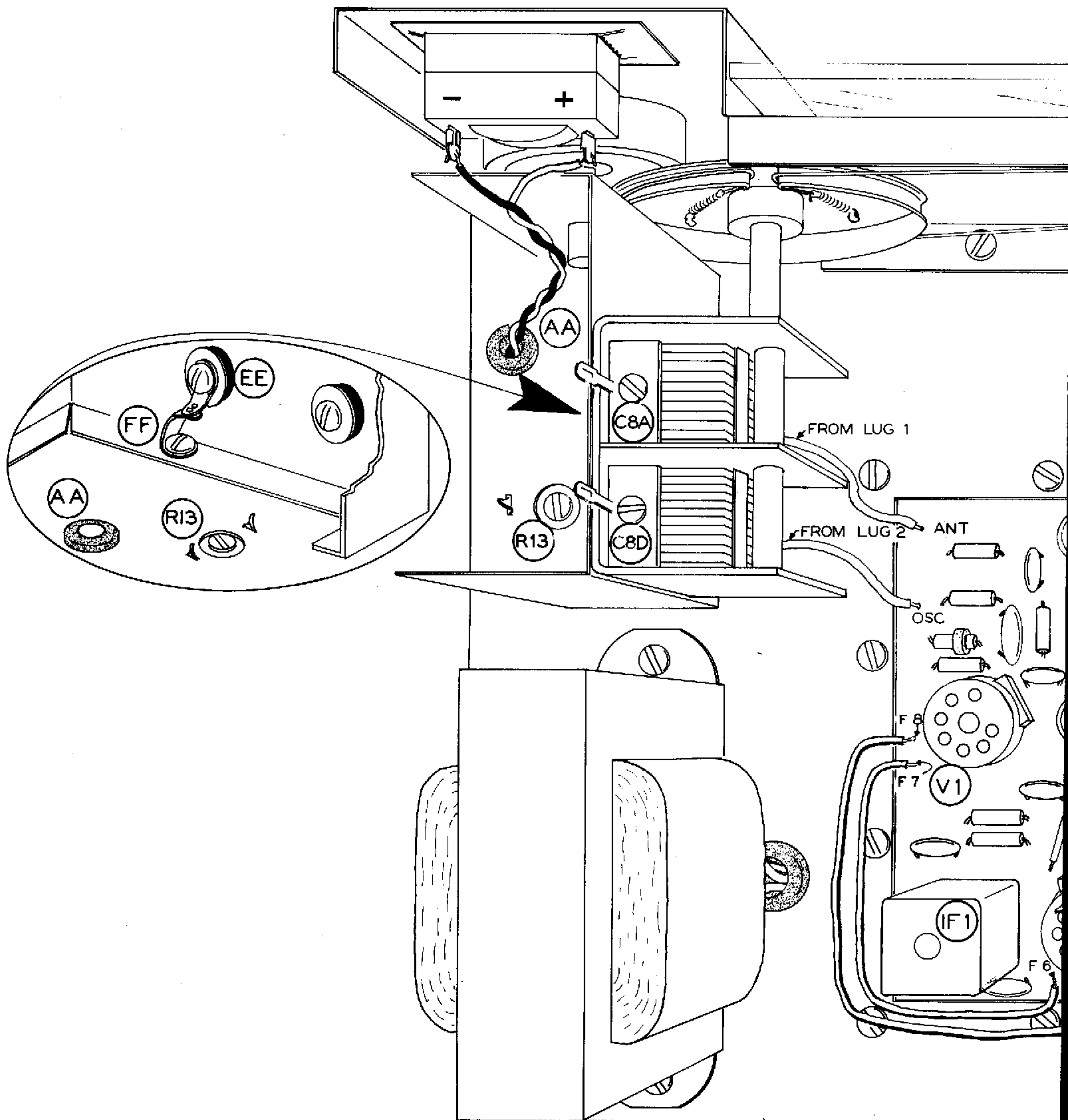

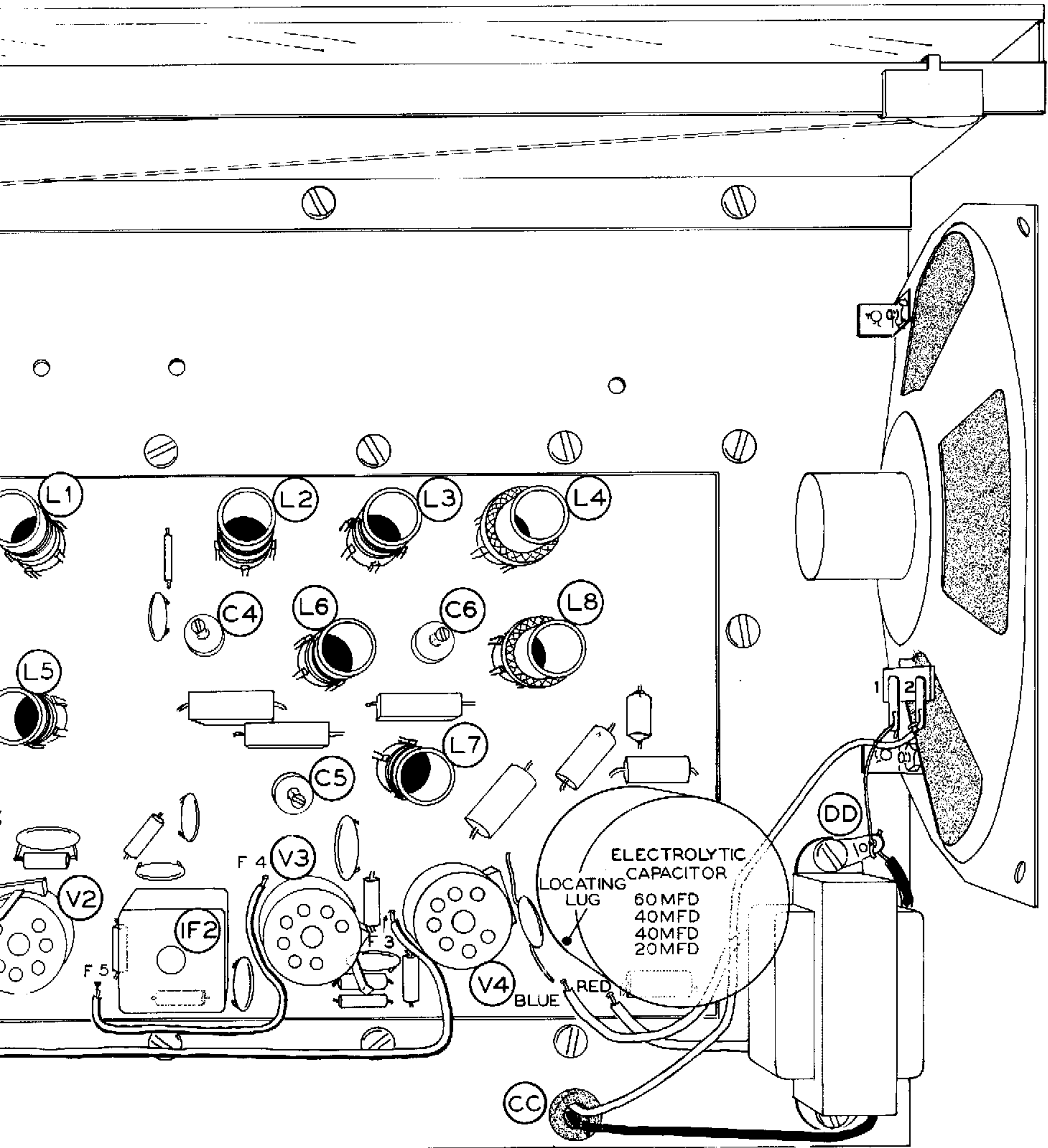

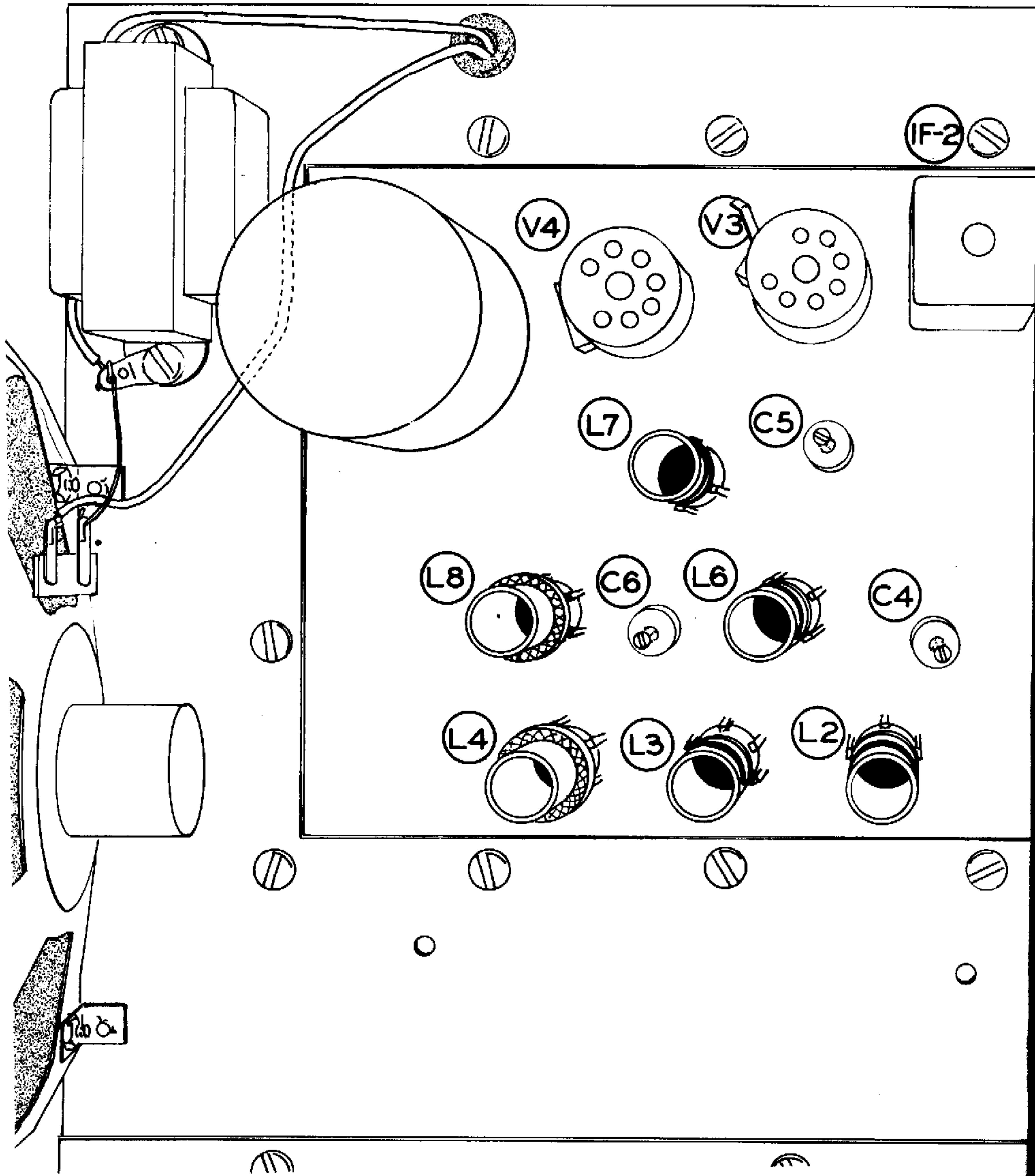

Fig

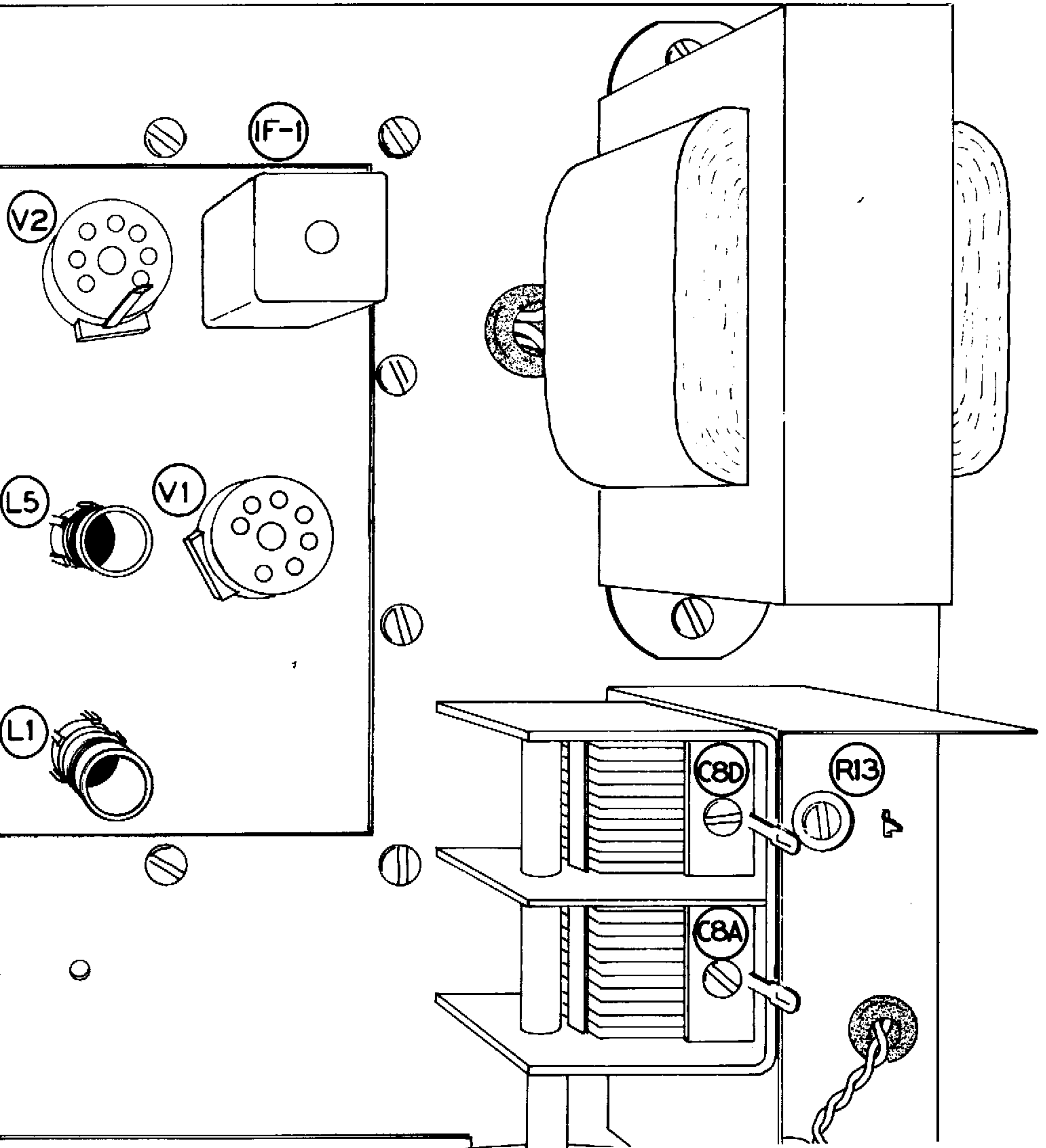

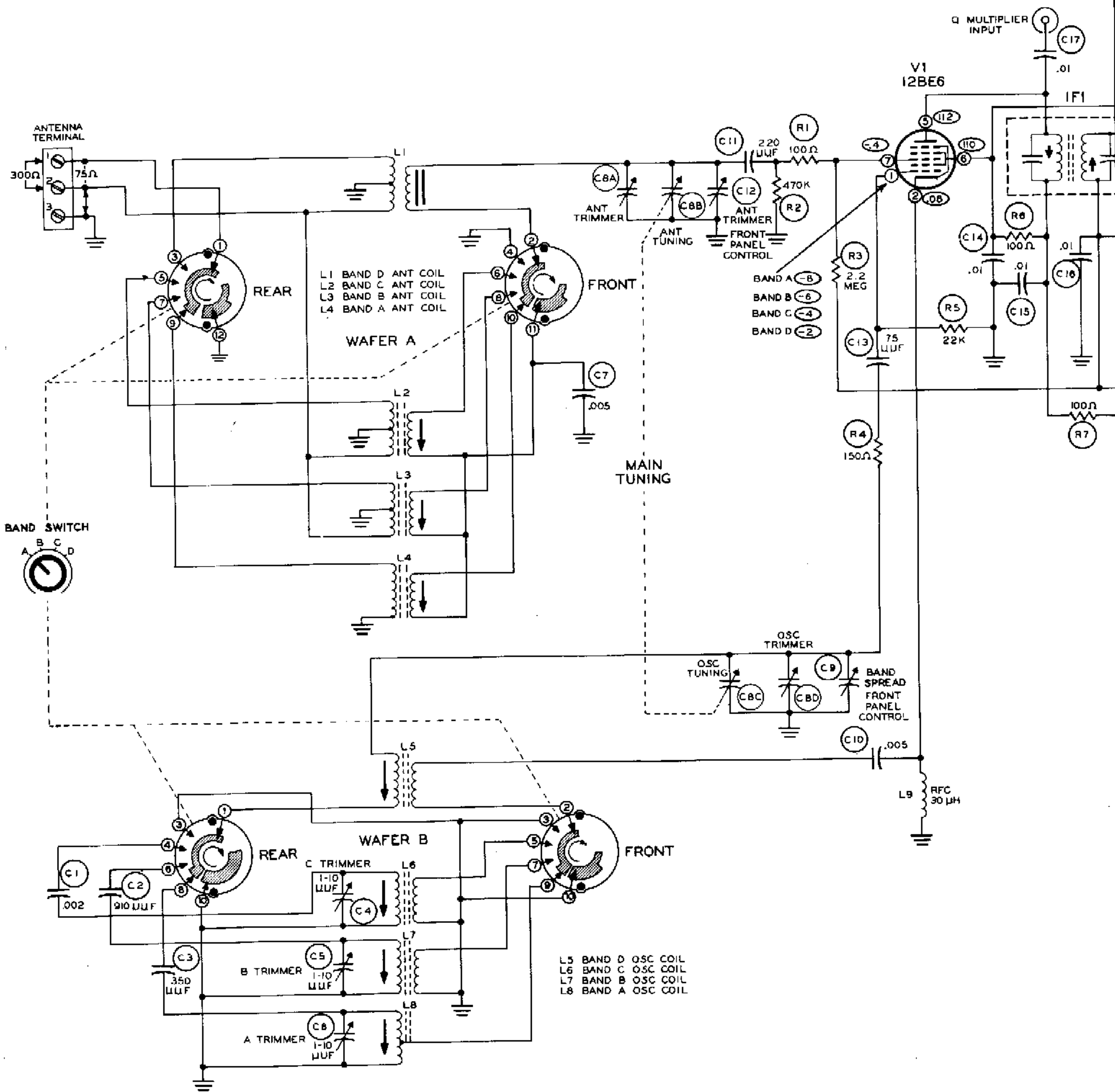

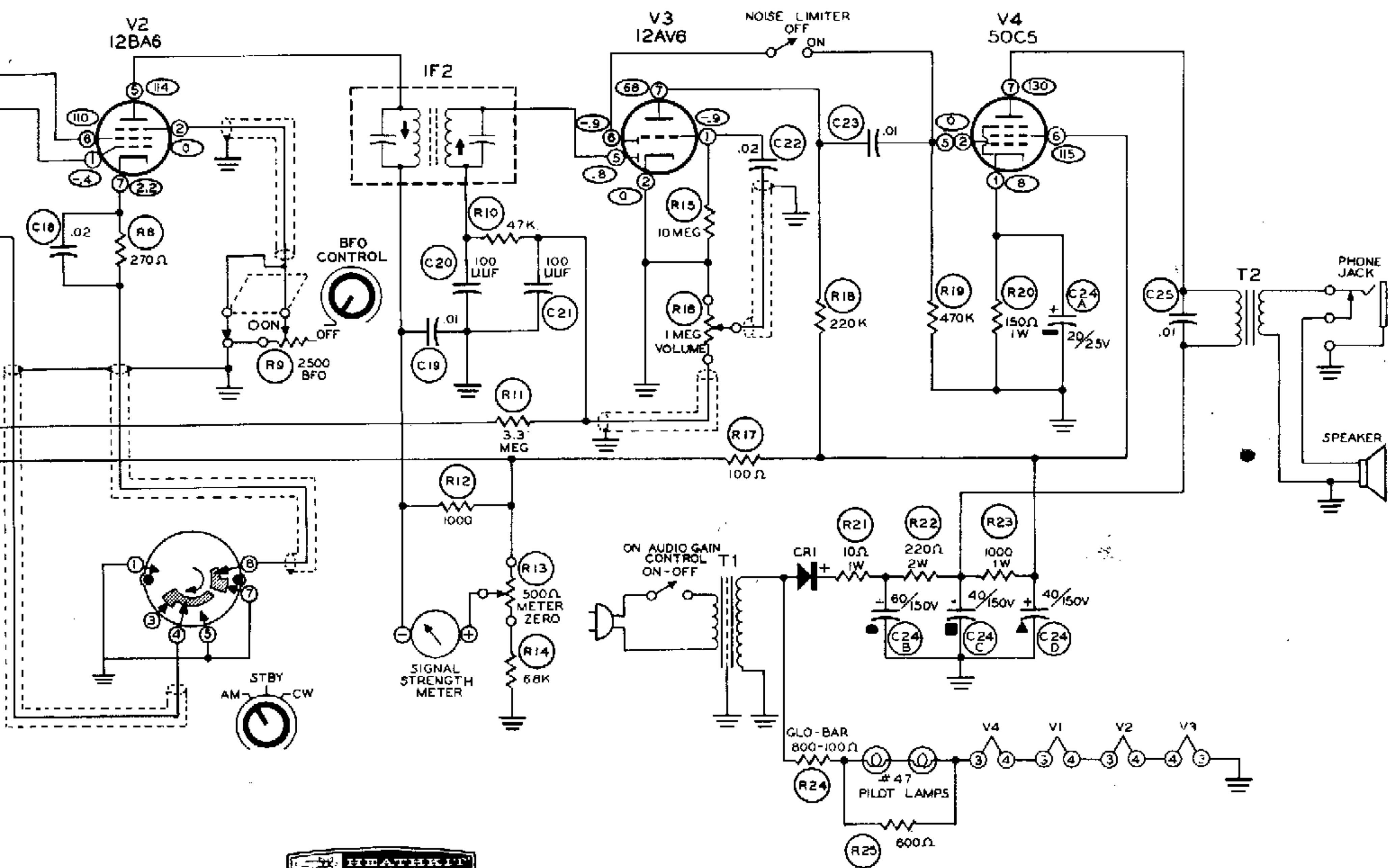

**GENERAL COVERAGE RECEIVER  
MODEL GR-91**

**NOTES:**

ROTARY SWITCHES IN POSITION SHOWN BY FRONT PANEL MARKINGS.  
 ROTARY SWITCHES VIEWED FROM FRONT PANEL.  
 ALL RESISTORS ARE 1/2 WATT UNLESS SPECIFIED OTHERWISE.  
 ALL RESISTOR VALUES ARE IN OHMS, K = 1000, MEG = 1,000,000.  
 ALL CAPACITOR VALUES ARE IN  $\mu$ F UNLESS SPECIFIED OTHERWISE.

○ INDICATES VOLTAGE READING.

ALL VOLTAGES ARE DC, MEASURED FROM POINT INDICATED TO CHASSIS.  
 VOLTAGES MAY VARY  $\pm 10\%$ .  
 VOLTAGES MEASURED WITH BFO-OFF, ANL-OFF.  
 READINGS WERE TAKEN WITH AN 11 MEGOHM INPUT VTVM.  
 SHIELDED WIRES SHOWN ARE TWISTED PAIRS OF HOOKUP WIRE.