

HEATHKIT[®] MANUAL

for the

AC POWER SUPPLY

Model HWA-2036-3

595-1943

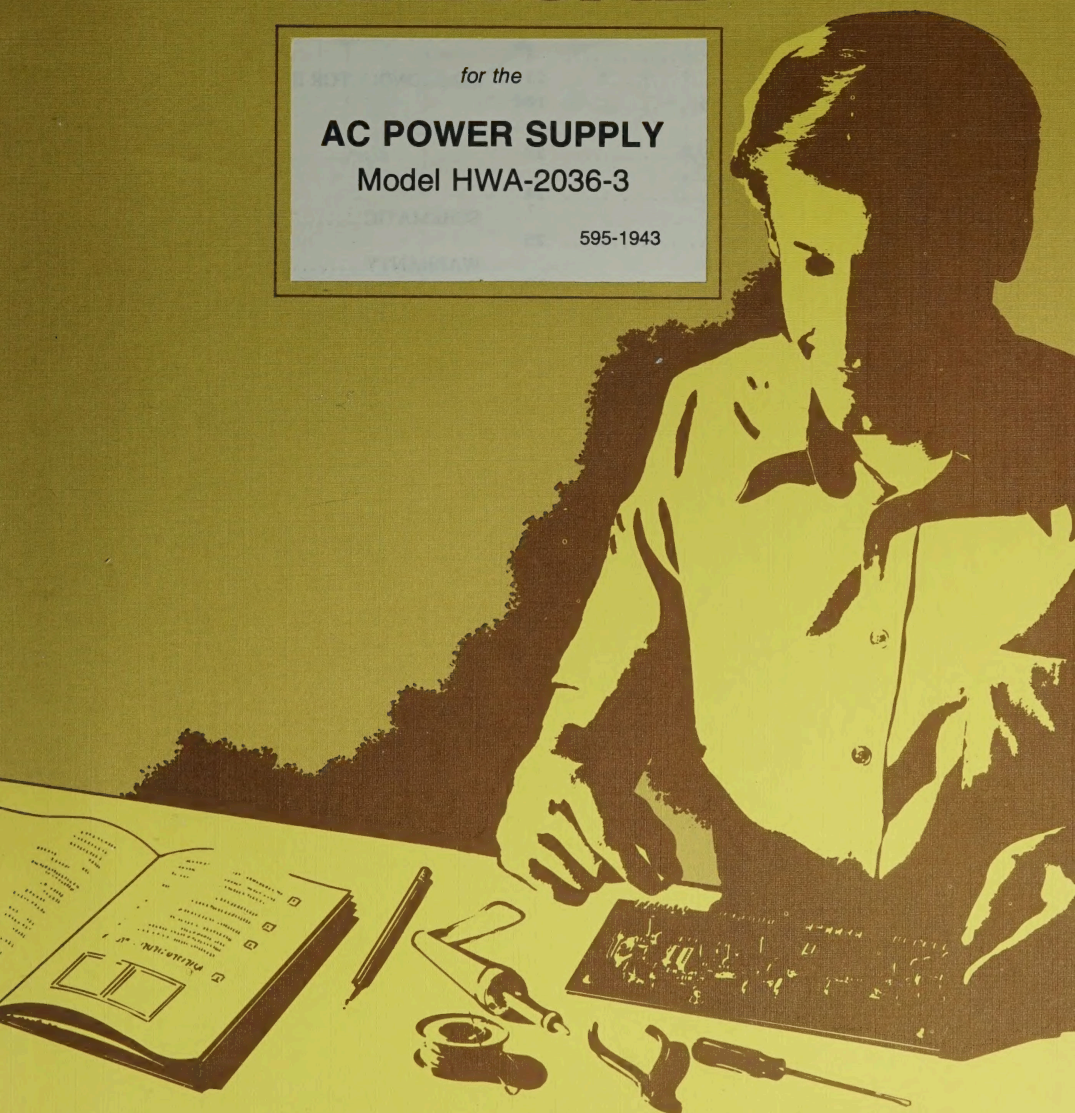

HEATH COMPANY • BENTON HARBOR, MICHIGAN

HEATH COMPANY PHONE DIRECTORY

The following telephone numbers are direct lines to the departments listed:

Kit orders and delivery information	(616) 982-3411
Credit	(616) 982-3561
Replacement Parts	(616) 982-3571
<i>Technical Assistance:</i>	
R,C, Audio, and Electronic Organs	(616) 982-3310
Amateur Radio	(616) 982-3296
Test Equipment, Strobe Lights, Calculators, Clocks, Weather Instruments	(616) 982-3315
Television	(616) 982-3307
Automotive, Marine, Appliances, Security, General Products	(616) 982-3496

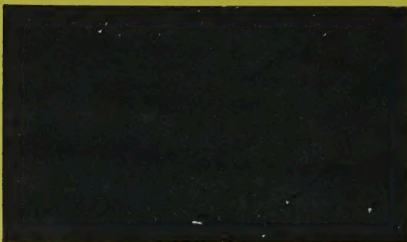

YOUR HEATHKIT 90-DAY FULL WARRANTY

During your first ninety (90) days of ownership, Heath Company will replace or repair free of charge — as soon as practical — any parts which are defective, either in materials or workmanship. You can obtain parts directly from Heath Company by writing us or telephoning us at (616) 982-3571. And we'll pay shipping charges to get those parts to you — anywhere in the world.

We warrant that, during the first ninety (90) days of ownership, our products, when correctly assembled, calibrated, adjusted, and used in accordance with our printed instructions, will meet published specifications.

If a defective part or error in design has caused your Heathkit product to malfunction during the warranty period, through no fault of yours, we will service it free upon delivery at your expense to the Heath factory, Benton Harbor, Michigan, or to any Heathkit Electronic Center (units of Schlumberger Products Corporation), or through any of our authorized overseas distributors.

You will receive free consultation on any problem you might encounter in the assembly or use of your Heathkit product. Just drop us a line or give us a call. Sorry, we cannot accept collect calls.

Our warranty, both expressed and implied, does not cover damage caused by use of corrosive solder, defective tools, incorrect assembly, misuse, fire, customer-made modifications, flood or acts of God, nor does it include reimbursement for customer assembly or setup time. The warranty covers only Heath products and is not extended to non-Heath allied equipment or components used in conjunction with our products or uses of our products for purposes other than as advertised.

And if you are dissatisfied with our service — warranty or otherwise — or our products, write directly to our Director of Customer Services, Heath Company, Benton Harbor, Michigan, 49022. He'll make certain your problems receive immediate, personal attention.

HEATH COMPANY
BENTON HARBOR, MI. 49022

Heathkit[®] Manual

for the

AC POWER SUPPLY

Model HWA-2036-3

595-1943

HEATH COMPANY
BENTON HARBOR, MICHIGAN 49022

Copyright © 1976
Heath Company
All Rights Reserved
Printed in the United States of America

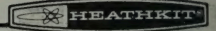

TABLE OF CONTENTS

PARTS LIST	3	SPECIFICATIONS	28
ASSEMBLY NOTES	5	CIRCUIT DESCRIPTION	29
STEP-BY-STEP ASSEMBLY		CIRCUIT BOARD X-RAY VIEW	30
Circuit board assembly	8	SEMICONDUCTOR IDENTIFICATION CHART	31
Chassis Assembly	13		
Wiring	18		
TESTS AND ADJUSTMENTS	22		
FINAL ASSEMBLY	24	SCHMATIC.....	In the Illustration Booklet
OPERATION	25	WARRANTY	Inside front cover
IN CASE OF DIFFICULTY	26	CUSTOMER SERVICE.....	Inside rear cover
Troubleshooting Chart.....	27		

PARTS LIST

Unpack the kit and check each part against the following list. The parts may vary slightly from the illustrations. The key numbers correspond to the numbers in the Parts Pictorial (Illustration Booklet, Page 1). Return any part that is packed in an individual envelope, with the part number on it back into the envelope, after you identify it, until it is called for in a step. Do not throw away any packing material until you account for all the parts.

Each circuit part has its own "Circuit Component Number" (R1, C3, Q2, etc.). This is a specific number for only that one part. The purpose of these numbers is to help you identify the same part in each section of this Manual. These numbers, which are especially useful if a part has to be replaced, appear:

- In the Parts List,

- At the beginning of each step where you install a component,
- In some illustrations,
- In the sections at the rear of this Manual,
- In the Schematic Diagram.

To order a replacement part, always include the part number and use the Parts Order Form furnished with this kit. If a Parts Order Form is not available, use one of the Parts Order Forms at the rear of this Manual, or refer to "Replacement Parts" inside the rear cover. Your Warranty is inside the front cover. For prices, refer to the separate "Heath Parts Price List."

KEY No.	HEATH Part No.	QTY.	DESCRIPTION	CIRCUIT Comp. No.
---------	----------------	------	-------------	-------------------

RESISTORS

NOTE: The following resistors have a tolerance of 10% unless otherwise noted. 10% is indicated by a fourth color band of silver; 5% is indicated by a gold fourth band.

A1	1-49	1	22 Ω, 1/2-watt (red-red-black)	R2 ✓
A1	1-9	1	1000 Ω, 1/2-watt (brown-black-red)	R6 ✓
A1	1-138	1	3900 Ω, 1/2-watt, 5% (orange-white-red)	R5 ✓
A1	1-51	1	6800 Ω, 1/2-watt, 5% (blue-gray-red)	R3 ✓
A1	1-22	1	22 kΩ, 1/2-watt (red-red-orange)	R1 ✓

CAPACITORS

B1	27-47	2	.1 μF Mylar*	C3, C4 ✓
B2	25-121	1	500 μF electrolytic	C2 ✓
B2	25-198	1	3500 μF electrolytic	C1 ✓

KEY No.	HEATH Part No.	QTY.	DESCRIPTION	CIRCUIT Comp. No.
---------	----------------	------	-------------	-------------------

DIODES — TRANSISTORS — INTEGRATED CIRCUIT (IC)

C1	57-27	1	1N2071 diode	D5 ✓
C1	57-71	4	S-5A05 diode	D1, D2, D3, D4 ✓

NOTE: Transistors and integrated circuits may be marked for identification in any of the following four ways:

1. Part number.
2. Type number. (On integrated circuits, this refers only to the numbers; the letters may be different or missing.)
3. Part number and type number.
4. Part number with a type number other than the one listed.

D1	417-215	1	2N3055 transistor	Q2 ✓
D2	417-224	1	MPSU05 transistor	Q1 ✓
D3	442-626	1	UA78MGT4C integrated circuit	IC1 ✓

KEY No.	HEATH Part No.	QTY.	DESCRIPTION	CIRCUIT Comp. No.
---------	----------------	------	-------------	-------------------

OTHER ELECTRONIC COMPONENTS

E1	10-918	1	500 Ω control	R4 ✓
E2	63-269	1	Switch	SW1 ✓
E3	412-15	1	Neon lamp	PL1 ✓
E4	421-2	1	3-ampere fuse	F2 ✓
E4	421-29	1	3/4-ampere, slow-blow fuse	F1 ✓
	54-935	1	Power transformer	T1 ✓

HARDWARE

F1	250-170	12	#6 \times 1/4" sheet metal screw
F2	250-89	7	6-32 \times 3/8" screw
F3	250-206	2	6-32 \times 11/16" screw
F4	252-3	5	6-32 nut
F5	254-1	9	#6 lockwasher
F6	254-6	1	#6 external tooth lockwasher
F7	259-1	1	#6 solder lug
F8	255-11	2	6-32 threaded spacer
F9	250-137	4	8-32 \times 3/8" screw
F10	250-72	1	8-32 \times 3/4" screw
F11	252-4	5	8-32 nut
F12	252-28	1	8-32 thumbnut
F13	253-45	2	#8 flat washer
F14	254-2	5	#8 lockwasher
F15	259-2	1	#8 solder lug
F16	252-7	3	Control nut
F17	252-73	1	Push-on nut
F18	253-10	1	Control flat washer
F19	254-5	1	Control lockwasher
F20	255-1	2	1/8" spacer

KEY No.	HEATH Part No.	QTY.	DESCRIPTION	CIRCUIT Comp. No.
---------	----------------	------	-------------	-------------------

METAL PARTS

G1	90-588-2	1	Cabinet shell
G2	200-1289-1	1	Chassis
G3	203-1455-2	1	Front panel
G4	204-1882	1	Bracket
G5	210-58	1	Bezel

MISCELLANEOUS

H1	75-24	1	Small strain relief
H2	75-71	1	Large strain relief
H3	75-88	1	Transistor cover
H4	75-44	1	Mica insulator (packed between two pieces of cardboard).
	85-1977-1	1	Circuit board
	89-23	1	Line cord
H5	259-20	9	Connector pin (1 extra)
H6	261-29	4	Foot
	344-2	2-1/2'	Black wire
	344-3	7-1/2'	Red wire
	344-59	1'	White wire
H7	352-13	1	Silicone grease
H8	413-10	1	Red lens
H9	422-1	1	Fuse block
H10	423-2	1	Fuseholder
H11	431-42	2	Terminal strip
H12	434-117	1	Transistor socket
H13	462-309	1	Knob
H14	490-5	1	Nut starter

Solder

PRINTED MATERIAL

J1	390-1255	1	Fuse label
J2	391-34	1	Blue and white label
	597-260	1	Parts Order Form
		1	Assembly Manual (See Page 1 for part number.)

ASSEMBLY NOTES

TOOLS

You will need these tools to assemble your kit.

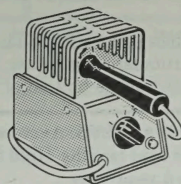
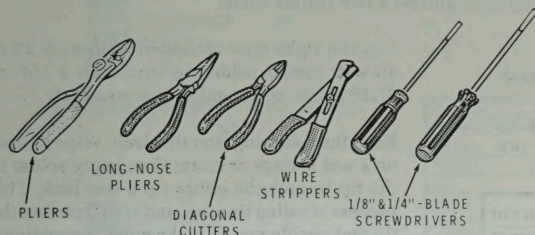

HEATHKIT
SOLDERING
IRON

OR

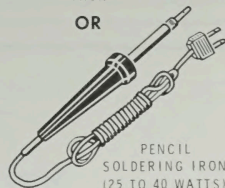

PENCIL
SOLDERING IRON
(25 TO 40 WATTS)

OTHER HELPFUL TOOLS



NUT STARTER
(MAY BE SUPPLIED
WITH KIT)



DESOLDERING
BULB*



DESOLDERING
BRAID*

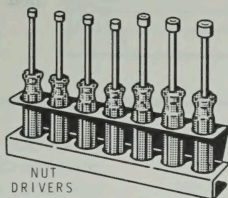

NUT
DRIVERS

*TO REMOVE SOLDER FROM CIRCUIT CONNECTIONS.

ASSEMBLY

- Follow the instructions carefully and read the entire step before you perform the operation.
- The illustrations in the Manual are called Pictorials and Details. Pictorials show the overall operation for a group of assembly steps; Details generally illustrate a single step. When you are directed to refer to a certain Pictorial "for the following steps," continue using that Pictorial until you are referred to another Pictorial for another group of steps.
- Most kits use a separate "Illustration Booklet" that contains illustrations (Pictorials, Details, etc.) that are too large for the Assembly Manual. Keep the "Illustration Booklet" with the Assembly Manual. The illustrations in it are arranged in Pictorial number sequence.
- Position all parts as shown in the Pictorials.
- Solder a part or a group of parts only when you are instructed to do so.

6. Each circuit part in an electronic kit has its own component number (R2, C4, etc.). Use these numbers when you want to identify the same part in the various sections of the Manual. These numbers, which are especially useful if a part has to be replaced, appear:
- In the Parts List,
 - At the beginning of each step where a component is installed,
 - In some illustrations,
 - In the Schematic,
 - In the section at the rear of the Manual.
7. When you are instructed to cut something to a particular length, use the scales (rulers) provided at the bottom of the Manual pages.

SAFETY WARNING: Avoid eye injury when you cut off excess lead lengths. Hold the leads so they cannot fly toward your eyes.

SOLDERING

Soldering is one of the most important operations you will perform while assembling your kit. A good solder connection will form an electrical connection between two parts, such as a component lead and a circuit board foil. A bad solder connection could prevent an otherwise well-assembled kit from operating properly.

It is easy to make a good solder connection if you follow a few simple rules:

1. Use the right type of soldering iron. A 25 to 40-watt pencil soldering iron with a 1/8" or 3/16" chisel or pyramid tip works best.
2. Keep the soldering iron tip clean. Wipe it often on a wet sponge or cloth; then apply solder to the tip to give the entire tip a wet look. This process is called tinning, and it will protect the tip and enable you to make good connections. When solder tends to "ball" or does not stick to the tip, the tip needs to be cleaned and retinned.

PARTS

Resistors will be called out by their resistance value in Ω (ohms), $k\Omega$ (kilohms), or $M\Omega$ (megohms). Certain types of resistors will have the value printed on the body, while others will be identified by a color code. The colors of the bands and the value will be given in the steps, therefore the following color code is given for information only.

EXAMPLES:

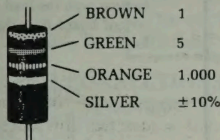

$$15 \times 1,000 = 15,000 \Omega \text{ (15,000 OHMS), or "15 } k\Omega \text{"}$$

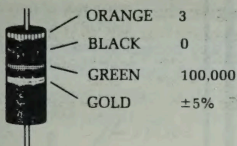

$$30 \times 100,000 = 3,000,000 \Omega \text{ (or 3 } M\Omega) \\ 3 M\Omega = 3 \text{ MEGOHMS}$$

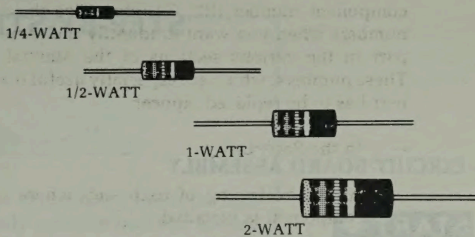

RESISTOR COLOR CODE

TOLERANCE
 Gold 5%
 Silver 10%
 No Band 20%

COLOR	1st DIGIT	2nd DIGIT	MULTIPLY BY
BLACK	0	0	1
BROWN	1	1	10
RED	2	2	100
ORANGE	3	3	1,000
YELLOW	4	4	10,000
GREEN	5	5	100,000
BLUE	6	6	1,000,000
VIOLET	7	7	10,000,000
GRAY	8	8	100,000,000
WHITE	9	9	1,000,000,000
GOLD			.1
SILVER			.01

Capacitors will be called out by their capacitance value in μF (microfarads) or pF (picofarads) and type: ceramic, Mylar*, electrolytic, etc. Some capacitors may have their value printed in the following manner:

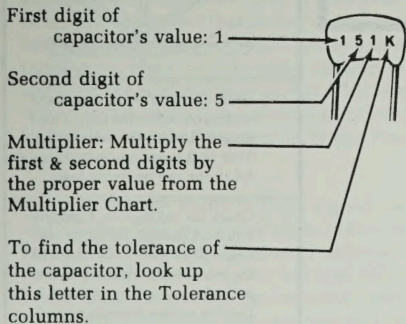

EXAMPLES:

$$151K = 15 \times 10 = 150 pF \\ 759 = 75 \times 0.1 = 7.5 pF$$

NOTE: The letter "R" may be used at times to signify a decimal point; as in: 2R2 = 2.2 (pF or μF).

MULTIPLIER		TOLERANCE OF CAPACITOR		
FOR THE NUMBER:	MULTIPLY BY:	10pF OR LESS	LETTER	OVER 10pF
0	1	$\pm 0.1 pF$	B	
1	10	$\pm 0.25 pF$	C	
2	100	$\pm 0.5 pF$	D	
3	1000	$\pm 1.0 pF$	F	$\pm 1\%$
4	10,000	$\pm 2.0 pF$	G	$\pm 2\%$
5	100,000		H	$\pm 3\%$
			J	$\pm 5\%$
8	0.01		K	$\pm 10\%$
9	0.1		M	$\pm 20\%$

STEP-BY-STEP ASSEMBLY

CIRCUIT BOARD ASSEMBLY

START →

(✓) Position the circuit board as shown with the printed side (not the foil side) up. Then complete the steps in the following Pictorials.

NOTE: In the following steps you will be given detailed instructions on how to install and solder the first part on a circuit board. Read and perform each step carefully. Then use the same procedure whenever you install parts on a circuit board.

(✓) R2: Hold a 22 Ω (red-red-black) resistor by the body as shown and bend the leads straight down.

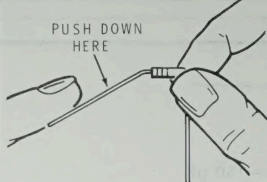

(✓) Push the leads through the holes at the proper location on the circuit board. The end with color bands may be positioned either way.

(✓) Press the resistor against the circuit board. Then bend the leads outward slightly to hold the resistor in place.

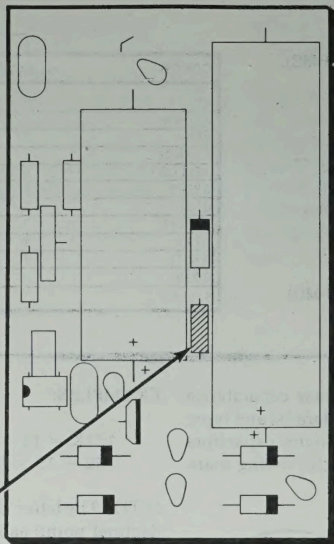
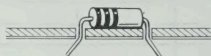

PICTORIAL 1

CONTINUE →

() Solder the resistor leads to the circuit board as follows:

1. Place the soldering iron tip against both the lead and the circuit board foil. Heat both for 2 or 3 seconds.

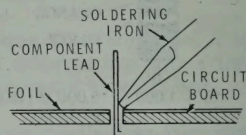

2. Then apply solder to the other side of the connection. IMPORTANT: Let the heated lead and the circuit board foil melt the solder.

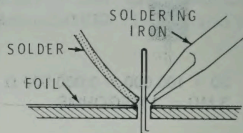

3. As the solder begins to melt, allow it to flow around the connection. Then remove the solder and the iron and let the connection cool.

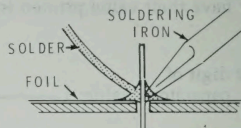

() Hold the lead with one hand while you cut off the excess lead length close to the connection. This will keep you from being hit in the eye by flying lead.

() Check the connection. Compare it to the illustrations on the next page. After you have checked the solder connections, proceed with the assembly on Page 9. Use the same soldering procedure for each connection.

A GOOD SOLDER CONNECTION

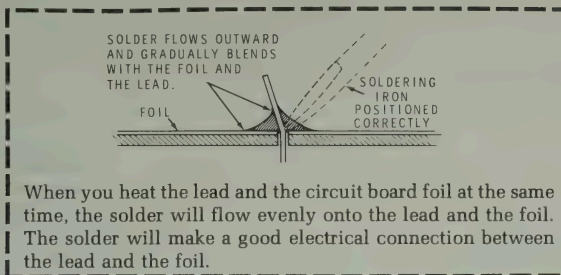

POOR SOLDER CONNECTIONS

SOLDER DOES NOT FLOW ONTO LEAD. A DARK ROSIN BEAD SURROUNDS AND INSULATES THE LEAD FROM THE CONNECTION.

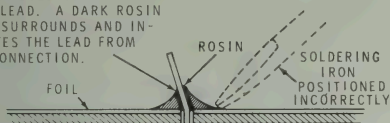

When the lead is not heated sufficiently, the solder will not flow onto the lead as shown above. To correct, reheat the connection and, if necessary, apply a small amount of additional solder to obtain a good connection.

SOLDER APPEARS TO FLOW INWARD AND SET ON TOP OF THE FOIL.

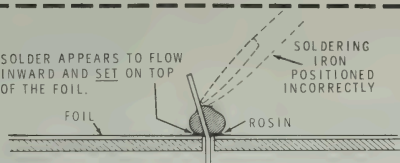

When the foil is not heated sufficiently the solder will blob on the circuit board as shown above. To correct, reheat the connection and, if necessary, apply a small amount of additional solder to obtain a good connection.

SOLDER BRIDGES

A solder bridge between two adjacent foils is shown in photograph A below. Photograph B shows how the connection should appear. A solder bridge may occur if you accidentally touch an adjacent previously soldered connection, if you use too much solder, or if you "drag" the soldering iron across other foils as you remove it from the connection. A good rule to follow is: always take a good look at the foil area around each lead before you solder it. Then, when you solder the connection, make sure the solder remains in this area and does not bridge to another foil. This is especially important when the foils are small and close together. NOTE: It is alright for solder to bridge two connections on the same foil.

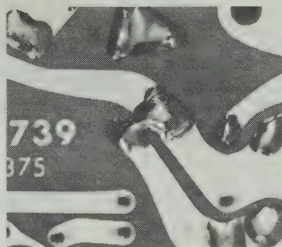

Use only enough solder to make a good connection, and lift the soldering iron straight up from the circuit board. If a solder bridge should develop, turn the circuit board foil-side-down and heat the solder between connections. The excess solder will run onto the tip of the soldering iron, and this will remove the solder bridge. NOTE: The foil side of each circuit board has a coating on it called "solder resist." This is a protective insulation to help prevent solder bridges.

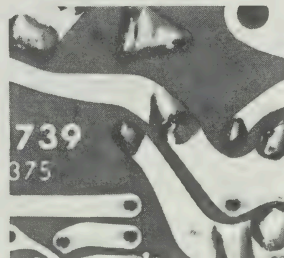

START ↘

- (✓) R3: 6800 Ω (blue-gray-red).
- (✓) R6: 1000 Ω (brown-black-red).
- (✓) R5: 3900 Ω (orange-white-red).
- () Solder the leads to the foil and cut off the excess lead lengths.
- (/) IC1: UA78MCT4C integrated circuit (#442-626). Position the IC so the tab is on the side of the IC as shown on the circuit board outline. Then insert the IC leads into their corresponding holes, press the IC down tight against the circuit board, and solder each lead to the foil.

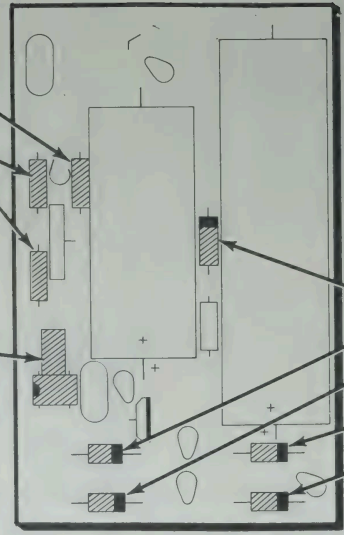
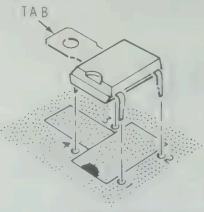

CONTINUE ↘

IMPORTANT: THE BANDED END OF DIODES CAN BE MARKED IN A NUMBER OF WAYS.

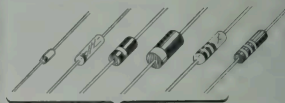

BANDED END

When you install a diode, always match the band on the diode with the band mark on the circuit board. A DIODE WILL NOT WORK IF INSTALLED BACKWARDS.

BANDED END

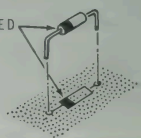

- (✓) D5: 1N2071 diode (#57-27).
- (✓) D4: S-5A05 diode (#57-71).
- (/) D3: S-5A05 diode (#57-71).
- (✓) D2: S-5A05 diode (#57-71).
- (✓) D1: S-5A05 diode (#57-71).
- (✓) Solder the leads to the foil and cut off the excess lead lengths.

PICTORIAL 2

CONTINUE ↘

NOTE: In the following steps, install connector pins in the holes as shown. Push the connectors into the holes until the stop ridge is down firmly against the circuit board. Then solder the connectors to the foil.

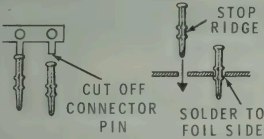

(/) Connector pin at "+DC REGULATED."

(/) Connector pin at GND.

(/) Connector pin at E.

(✓) Connector pin at A.

(✓) Connector pin at B.

(✓) Connector pin at RED.

(✓) Connector pin at RED.

(✓) Connector pin at C.

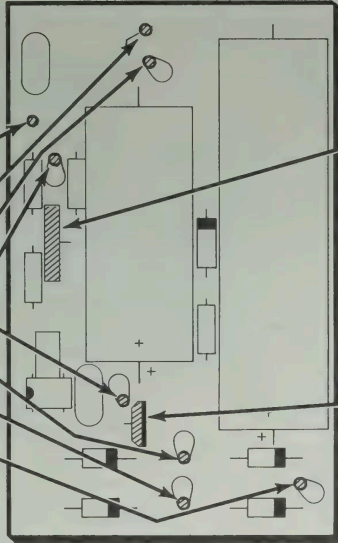

START ↘

(/) R4: 500 Ω control. Solder the lugs to the foil.

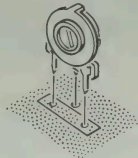

(✓) Q1: MPSU05 transistor (#417-224). First identify the C, B, and E leads by the C, B, and E stamped on top of the transistor. Then insert the leads into their correct holes, which are identified by C, B, and E. Solder the leads to the foil and cut off the excess lead lengths.

LEAD IDENTIFICATION
EBC

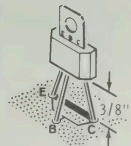

PICTORIAL 3

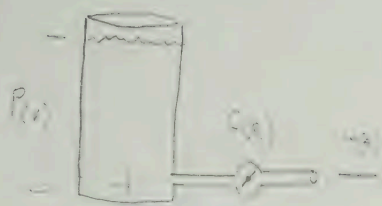

START

(✓) C4: .1 μ F Mylar.

NOTE: When you install electrolytic capacitors, always match the positive (+) mark on the capacitor with the positive (+) mark on the circuit board.

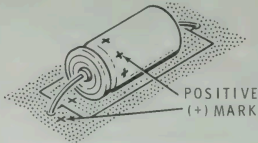

(✓) C2: 500 μ F electrolytic.

(✓) C1: 3500 μ F electrolytic.

(✓) C3: .1 μ F Mylar.

(✓) Solder the leads to the foil and cut off the excess lead lengths.

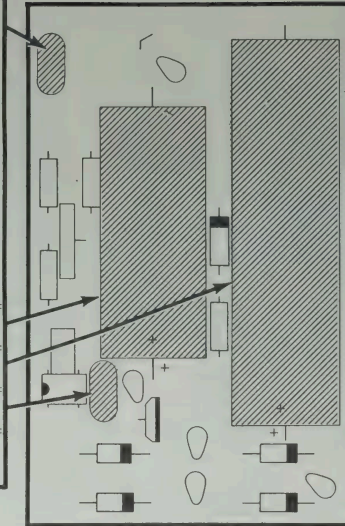
CONTINUE
CIRCUIT BOARD CHECKOUT

Carefully inspect the circuit board for the following conditions.

- (✓) Unsoldered connections.
- (✓) Poor solder connections.
- (✓) Solder bridges between foil patterns.
- (✓) Protruding leads which could touch together.
- (✓) Integrated circuit for the proper **type** and **installation**.
- (✓) Electrolytic capacitors for the correct position of the positive (+) end.
- (✓) Transistor for proper installation.
- (✓) Diodes for the correct position of the banded end.

The circuit board wire connections will be made later. Temporarily set the circuit board aside.

FINISH

PICTORIAL 4

CHASSIS ASSEMBLY

NOTE: When a step calls for hardware, only the screw size will be given. For instance, if a step calls for "8-32 x 3/4" hardware," it means you should use an 8-32 x 3/4" screw, one or more #8 lockwashers, and an 8-32 nut at each mounting hole. The Detail referred to in the step will show the proper number of lockwashers to use.

Refer to Pictorial 5 (Illustration Booklet, Page 2) for the following steps.

- (✓) Position the chassis as shown in the Pictorial.
- (✓) Refer to the inset drawing on the Pictorial and form the #8 solder lug as shown.

NOTE: When you mount the following parts onto the chassis, be sure to position them as shown in the Pictorial.

- (✓) Refer to Detail 5A and mount the prepared #8 solder lug at hole A with 8-32 x 3/4" hardware. Then install two #8 flat washers and an 8-32 thumbnut onto the screw.

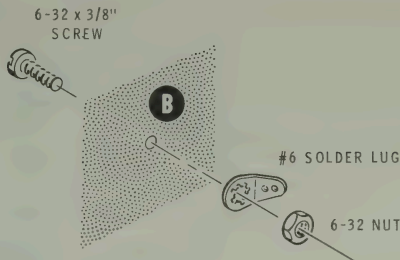
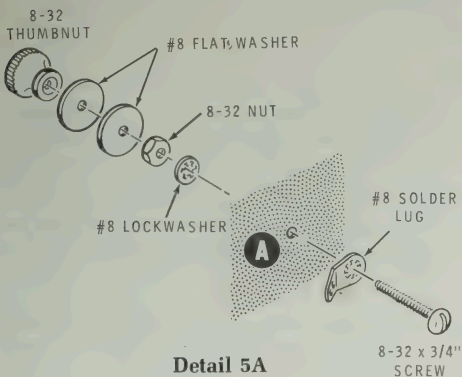

Detail 5B

NOTE: Use the plastic nut starter to hold and start 6-32 nuts on screws.

- (✓) Refer to Detail 5B and mount a #6 solder lug at hole B with 6-32 x 3/8" hardware.
- (✓) Refer to Detail 5C and mount the fuse block at F1 with 6-32 x 3/8" hardware. Be sure to use a #6 external tooth lockwasher between the fuse block and the chassis.

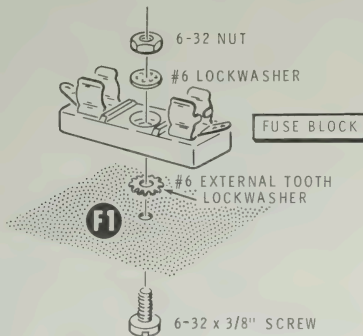

Detail 5C

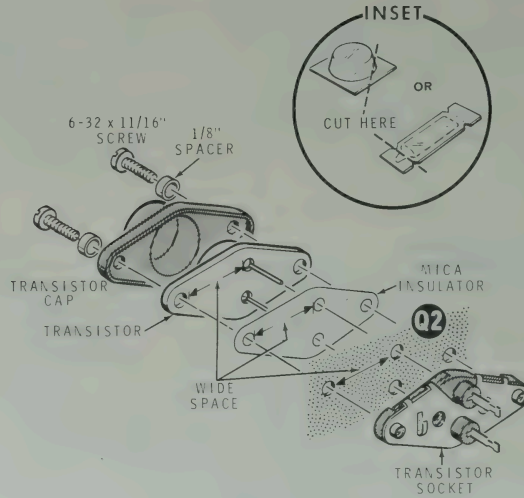

Detail 5E

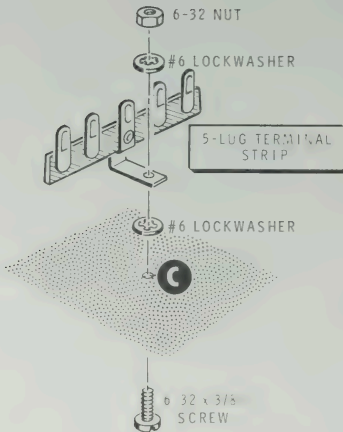

Detail 5D

(✓) Refer to Detail 5D and mount a 5-lug terminal strip at C with 6-32 x 3/8" hardware.

NOTE: When you mount the following transistor, be sure the indicated wide space on the transistor, mica insulator, and transistor socket lines up with the wide space on the chassis.

(✓) Q2: Refer to Detail 5E and the inset drawing to install a transistor socket, mica insulator, 2N3055 transistor (#417-215), 1/8" spacers, and transistor cap at Q2. First, open the silicone grease pod as shown in the inset drawing and spread a thin layer of silicone grease on both sides of the mica insulator. Note the wide space, place the insulator on the transistor, and insert the transistor leads into the socket. Mount the cap with 6-32 x 11/16" screws and 1/8" spacers.

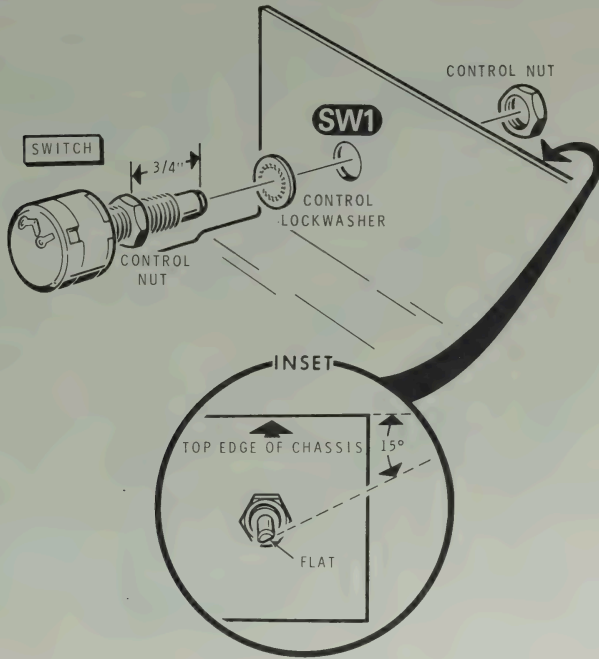

Detail 5F

- () SW1: Refer to Detail 5F and position a control nut and a control lockwasher 3/4" away from the shaft end of the switch. Then loosely mount the switch to the chassis at SW1 with a control nut.
- () Turn the switch shaft to the counterclockwise position and position the switch so the flat on the shaft will make a 15° angle to the top edge of the chassis as shown in the inset drawing in Detail 5F. Then tighten the control nut.
- () Locate the front panel and mount a red lens at D with a push-on nut as shown in Detail 5G.
- () Turn a 6-32 nut against the front panel on stud E.

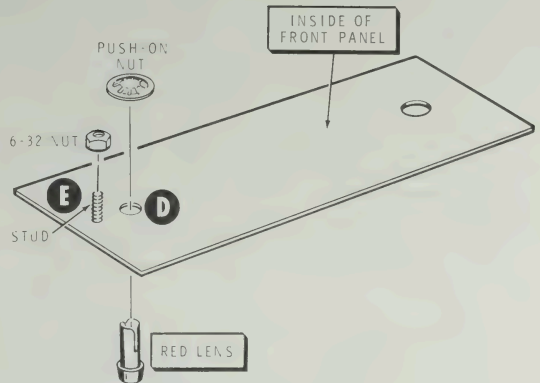

Detail 5G



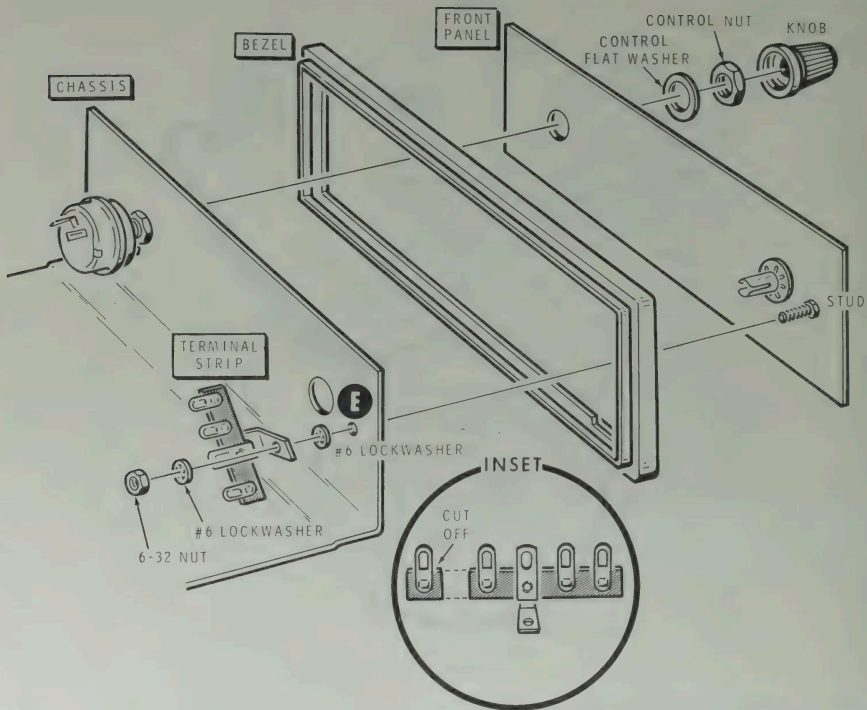

Detail 5H

- (/) Mount the front panel and bezel onto the chassis with a control flat washer and a control nut. Refer to Detail 5H and position the bezel as shown.
- (V) Line up the flat on the shaft with the flat on the knob. Then press the knob onto the switch shaft.
- (^) Refer to Detail 5H and cut the indicated lug from a 5-lug terminal strip as shown in the inset drawing. Mount the terminal strip onto front panel stud E with two #6 lockwashers and a 6-32 nut. Position the terminal strip so there will be 3/8" clearance above lug 1 as shown in Detail 5J.

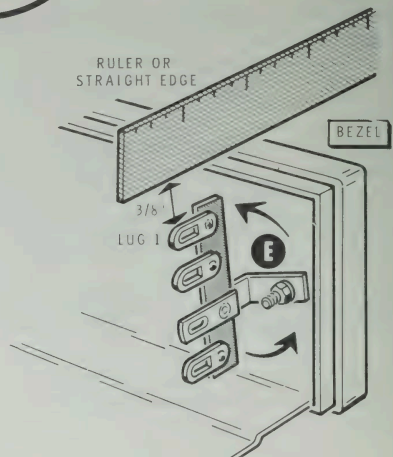

Detail 5J

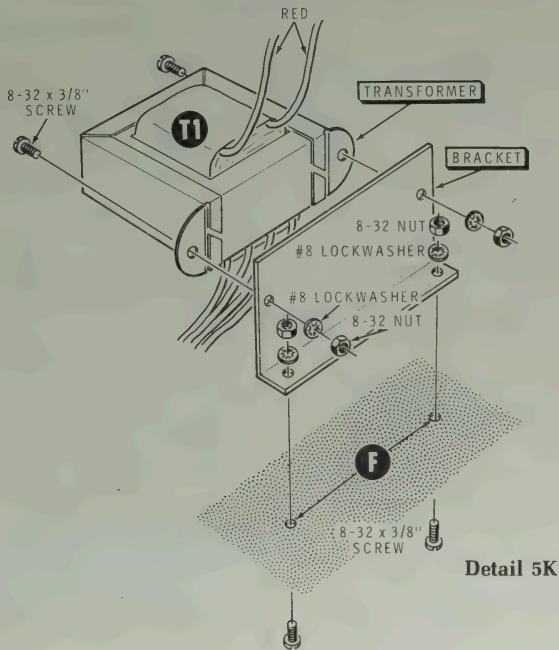

- (✓) T1: Refer to Detail 5K and mount the power transformer to the bracket with 8-32 × 3/8" hardware. Be sure to position the transformer with the red leads as shown.
- (✓) Again refer to Detail 5K and mount the bracket and transformer to the chassis at F with 8-32 × 3/8" hardware. Be sure to position the four leads nearest the chassis as shown in the Pictorial.

- (✓) Mount the circuit board to the chassis at G with 6-32 × 3/8" hardware and 6-32 spacers as shown in Detail 5L. (Illustration Booklet, Page 2).
- (✓) Refer to Detail 5M and mount the fuseholder onto the chassis at F2. Use the hardware supplied with the fuseholder. Position lug 1 as shown.

- (✓) F2: Remove the fuseholder cap. (Push in and turn it counterclockwise.) Then insert the 3-ampere fuse into the fuseholder and replace the cap.

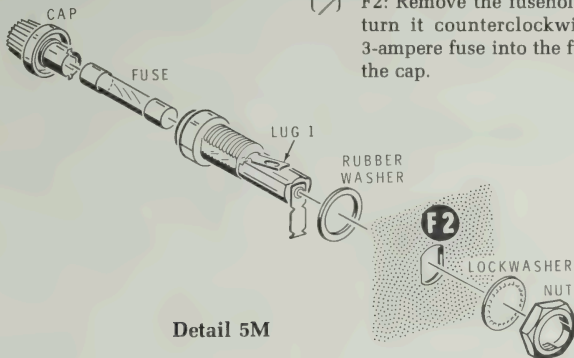

Detail 5M

WIRING

Refer to Pictorial 6 (Illustration Booklet, Page 3) for the following steps.

NOTES:

1. In the following steps, (NS) means not to solder because you will add other wires later. "S-" with a number, such as (S-3), means to solder the connection. The number following the "S" tells how many wires are at the connection.

2. Refer to the inset drawing on the Pictorial when you are directed to "make a mechanically secure connection."

(✓) Connect the black-red transformer lead to terminal strip C lug 1 (NS). Make a mechanically secure connection.

(✓) Connect the black-yellow transformer lead to terminal strip C lug 2 (NS). Make a mechanically secure connection.

NOTE: Terminal strip C lug 3 will not be used.

(✓) Connect the black-green transformer lead to terminal strip C lug 4 (NS). Make a mechanically secure connection.

(✓) Connect the black transformer lead to terminal strip C lug 5 (NS). Make a mechanically secure connection.

(✓) Connect either red transformer lead to either RED connector pin on the circuit board (S-1).

(✓) Connect the other red transformer lead to the remaining RED connector pin on the circuit board (S-1).

(✓) Cut a 9" white wire and remove 3/8" of insulation from each end.

(✓) Connect the 9" white wire from fuseholder F2 lug 1 (NS) to circuit board connector pin A (S-1).

NOTE: When you wire this kit, you will be instructed to prepare the wires ahead of time. To prepare a wire, cut it to the indicated length and remove 3/8" of insulation from each end. Twist together the small strands of wire at the end of each lead; then melt a small amount of solder on each of the exposed ends. The wires are listed in the order in which you will use them.

() Prepare the following wires:

3-1/2" red	9" red
8-1/2" red	Two 8" red
5" red	7-1/2" red
5" black	9" red

Connect the prepared wires in the following steps and position them as shown in the Pictorial.

(✓) 3-1/2" red wire from transistor socket Q2 lug 2 (S-1) to circuit board connector pin E (S-1). Do not solder the transistor lead to the lug.

(✓) 8-1/2" red wire from transistor socket Q2 lug 3 (S-1) to circuit board connector pin C (S-1).

(✓) 5" red wire from transistor socket Q2 lug 1 (S-1) to circuit board connector pin B (S-1). Do not solder the transistor lead to the lug.

(✓) Connect the 5" black wire from solder lug A (NS) to the GND connector pin on the circuit board (S-1).

(✓) 9" red wire from fuseholder F2 lug 2 (S-1) to the +DC REGULATED connector pin on the circuit board (S-1).

(✓) 8" red wire from fuse block F1 lug 1 (S-1) to switch SW1 lug 1 (S-1). Make mechanically secure connections.

(✓) 8" red wire from switch SW1 lug 2 (NS) to terminal strip C lug 1 (NS). Make mechanically secure connections.

(✓) 7-1/2" red wire from switch SW1 lug 2 (S-2) to terminal strip E lug 1 (NS). Make mechanically secure connections.

(✓) 9" red wire from terminal strip C lug 4 (NS) to terminal strip E lug 4 (NS). Make mechanically secure connections.

(✓) PL1: Insert the neon lamp into the red lens at D. Carefully remove all the insulation from a 1" length of red wire. Then slide the insulation onto one of the lamp leads. Connect this lamp lead to terminal strip E lug 1 (S-2).

(✓) Connect the other lamp lead to terminal strip E lug 2 (NS).

(✓) R1: Connect a 22 kΩ (red-red-orange) resistor between terminal strip D lug 2 (S-2) and 4 (S-2).

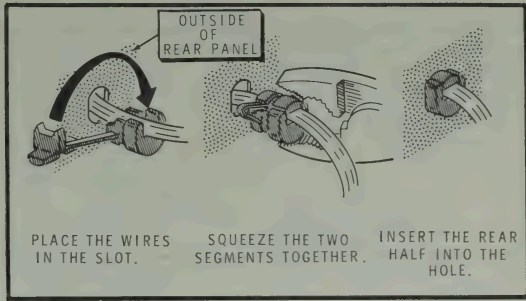

Detail 6A

- (✓) Prepare a 23" black and a 26" red wire.
- (✓) Connect the 23" black wire to solder lug A (S-2). Route the other end of the wire through hole H.
- (✓) Connect the 26" red wire to fuseholder F2 lug 1 (S-2). Route the other end of the wire through hole H.
- X () Refer to Detail 6A and install the small strain relief on the two wires coming from hole H.

() Refer to Detail 7B and prepare the free end of the line cord as shown. Refer to the inset drawing on the Pictorial for identification of the ribbed line cord lead.

() Insert the prepared end of the line cord through hole J and connect the smooth lead to fuse block F1 lug 2 (S-1). Make a mechanically secure connection.

Refer to Pictorial 7 (Illustration Booklet, Page 3) for the following steps.

(✓) Refer to Detail 7A and split the outer insulation of the line cord for 3" as follows, so you do not cut into the protective insulation for the AC leads.

1. Use a knife blade to score a 3" line BETWEEN the two grooves.
2. Turn the line cord over and repeat step 1.
3. Grasp the lead ends by the insulation and pull the leads apart. The line cord will separate on the scored lines.

() Connect the ribbed lead to terminal strip C lug 5 (NS). Make a mechanically secure connection.

(✓) Connect the green lead to solder lug B (S-1). Make a mechanically secure connection.

() Install the large strain relief on the line cord at hole J.

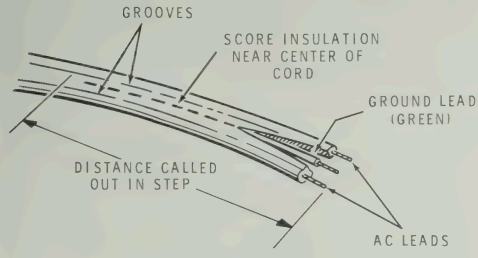

Detail 7A

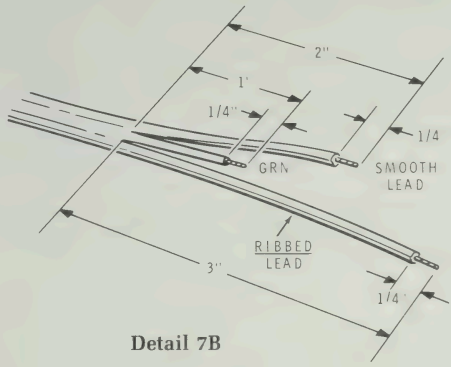

Detail 7B

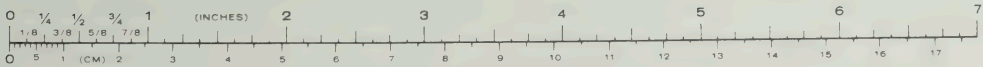

NOTE: Two different sets of wiring instructions are given in the following steps. One set of instructions is for 120 VAC line voltage (most often used in the United States), and the other is for 240 VAC line voltage. Use only the instructions that agree with the line voltage in your area.

For 120 VAC Only

Refer to Detail 7C for the following steps.

- (✓) Prepare two 1-1/4" red wires.
- (✓) Connect a 1-1/4" wire between terminal strip C lugs 1 (S-3) and 2 (S-2). Make mechanically secure connections.
- (✓) Connect the other 1-1/4" wire between terminal strip C lugs 4 (S-3) and 5 (S-3). Make mechanically secure connections.
- (✓) F1: Insert the 3/4-ampere fuse into fuse block F1.
- () Write "3/4-ampere, slow-blow" in the blanks on the fuse label.
- () Carefully peel the backing paper from the fuse label. Then press the label onto the chassis as shown. Do not cover any holes in the chassis.

This completes the 120 VAC wiring of your Power Supply. Proceed to the "Tests and Adjustments" section of this Manual.

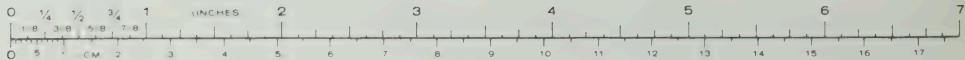
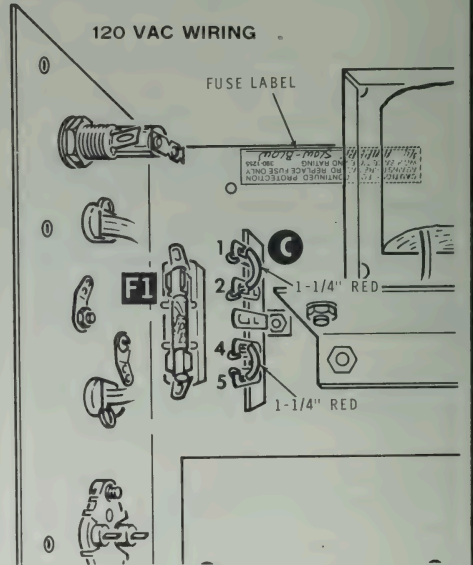

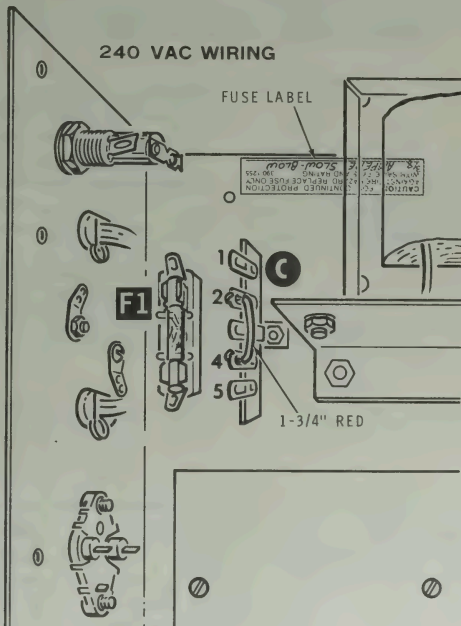

For 240 VAC Only

Refer to Detail 7D for the following steps.

- () Prepare a 1-3/4" red wire. Then connect the wire between terminal strip C lugs 2 (S-2) and 4 (S-3). Make mechanically secure connections.
- () Solder the wires connected to terminal strip C lugs 1 (S-2) and 5 (S-2).
- () F1: Insert a 3/8-ampere fuse (not supplied) into fuse block F1.
- () Write "3/8-ampere, slow-blow" in the blanks on the fuse label.
- () Carefully peel the backing paper from the fuse label. Then press the label onto the chassis as shown. Do not cover any holes in the chassis.

NOTE: The plug on the line cord in this kit is for standard 120 VAC outlets. For 240 VAC operation in the U.S.A., cut off the plug and replace it with a permanent plug that matches your 240 VAC receptacle. Be sure your power connection conforms with section 210-21 (b) of the National Electric Code, which reads in part:

"Receptacles connected to circuits having different voltages, frequencies, or types of current (AC or DC) on the same premises shall be of such design that attachment plugs used on such circuits are not interchangeable."

When you install a new plug, make sure it is connected according to your local electrical code. Keep in mind that the green line cord wire is connected to the chassis of the Power Supply.

This completes the 240 VAC wiring of your Power Supply. Proceed to the "Tests and Adjustments" section of this Manual.

TESTS AND ADJUSTMENTS

PRIMARY WIRING TESTS

A wiring error in the primary wiring circuit (line cord, Power switch, etc.) of your kit could cause you to receive a severe electrical shock. These "Primary Wiring Tests" will help you eliminate any such wiring errors that may exist.

- (✓) Be sure the line cord is not plugged in.
- (✓) Turn the POWER switch to OFF.

If you do not have an ohmmeter, carefully check the line cord, fuse block, Power switch, and transformer wiring against that shown in Pictorials 6 and 7 (Illustration Booklet, Page 3), and Detail 7C on Page 20, or 7D on Page 21. Make sure there are no fine strands of wire or solder globs touching adjacent terminals or the chassis. Then proceed to "Voltage Adjustment."

If you have an ohmmeter, perform the following resistance measurements. NOTE: You will be instructed to connect one of the ohmmeter leads to ground. This can be the chassis or the ground post on the rear panel.

- (✓) Place the ohmmeter in the RX10 position.

METER CONNECTIONS		METER READING	POSSIBLE CAUSE OF TROUBLE
RED LEAD	BLACK LEAD		
1. Either flat prong of the line cord plug.	Ground	INFINITE with the POWER switch ON or OFF.	A. Switch SW1 wiring. B. Terminal strip C wiring. C. T1.
2. Other flat prong of the line cord plug.	Ground	INFINITE with the POWER switch ON or OFF.	A. Switch SW1 wiring. B. Terminal strip C wiring. C. T1.
3. Round prong of the line cord plug.	Ground	0 Ω with the POWER switch ON or OFF.	A. Green lead of the line cord not properly connected at solder lug B. See Pictorial 7.
4. Either flat prong.	Other flat prong.	1 M Ω or higher (POWER Switch OFF).	A. Terminal strip C wiring. B. T1.
5. Either flat prong.	Other flat prong.	Approximately 10 Ω 120 or 240 VAC wiring. (POWER switch ON.)	A. Terminal strip C wiring. B. T1.

This completes the "Primary Wiring Tests." If all tests were satisfactory, proceed to "Secondary Resistance Checks." If any of the tests were not correct, you must make the corrections necessary to obtain the correct readings before you continue.

In the following steps, if you do not obtain the proper results, refer to the "In Case of Difficulty" section and correct the problem before you proceed.

SECONDARY RESISTANCE CHECK

If you have a VOM (or VTVM) available, make the following resistance check before you plug the line cord into an AC outlet.

- (/) Connect the black ohmmeter lead to the chassis and the red ohmmeter lead to fuseholder F2 lug 2. The meter indicator should rise slowly (charging of circuit components) and then stop at approximately 1000Ω on the $R \times 100$ ohmmeter range.
- (/) Disconnect the meter from the Power Supply.

VOLTAGE ADJUSTMENT

WARNING: When the line cord is connected to an AC outlet, AC voltage will be present at several places on the chassis. Be careful you do not contact this voltage or an electrical shock can result. Refer to Figure 1 (Illustration Booklet, Page 4).

In the following steps, if you do not obtain the desired results, turn the Power Supply off and refer to the "In Case of Difficulty" section.

- () Turn the POWER switch to OFF, if not already done.
- () Plug the line cord into a proper AC outlet.

NOTE: Do not let the Power Supply output wires touch anything when you perform the following steps.

- () Set your VTVM or VOM to read +15 volts DC.
- () Connect the common lead of the meter to the chassis.
- () Touch the positive meter lead to fuseholder F2 lug 2.
- () Turn the Power Supply on. The lamp should light.
- () Turn the VOLTAGE ADJUST control on the circuit board until the meter indicates +13.8 volts DC.
- () Turn the POWER switch to OFF and disconnect the line cord plug.
- () Disconnect the meter from the Power Supply.

This completes the "Tests and Adjustments." Proceed to "Final Assembly."

FINAL ASSEMBLY

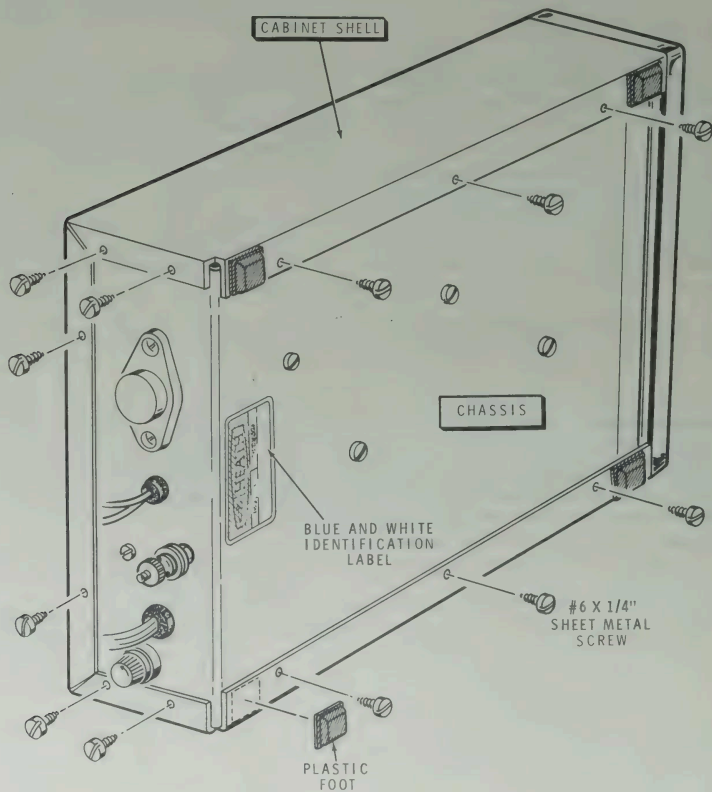

PICTORIAL 7

Refer to Pictorial 7 for the following steps.

- () Locate the cabinet shell and slide it over the chassis from the rear. Mount the shell with twelve #6 \times 1/4" sheet metal screws. Do not move the VOLTAGE ADJUST control on the circuit board.
- () Carefully peel the backing paper from each foot. Then press them into place as shown in the Pictorial.

- () Carefully peel the backing paper from the blue and white label. Then press the label onto the chassis bottom as shown. Be sure to refer to the numbers on this label in any correspondence you have with the Heath Company about this kit.

This completes the "Final Assembly." Proceed to "Operation."



OPERATION

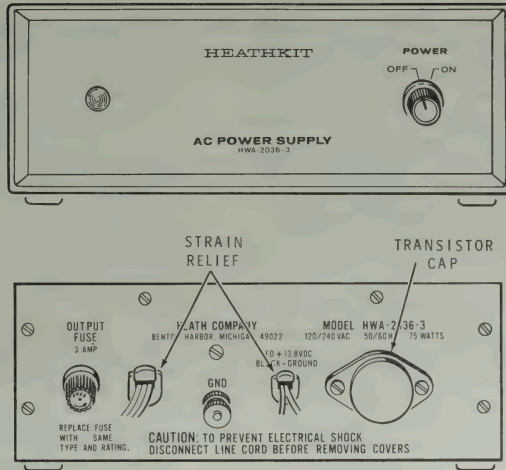

Figure 2

You can adjust the output voltage of this Power Supply between approximately 12.5 and 14.5 volts DC, as noted in the "Specifications" section. The recommended value for use with HW-202 and HW2036 Transceivers is 13.8 volts DC. To operate this AC Power Supply, simply connect the line cord to the proper AC outlet and connect the red wire to the positive input and the black wire to the negative input of the unit you wish to power. Then turn the POWER switch to the ON position.

Refer to Figure 2.

The GND post on the rear panel serves as a circuit ground point and a safety ground for any short circuits in the power wiring. Connect the GND post to your station ground or a good earth ground.

Connectors and instructions for using this Power Supply with the HW-202 and HW-2036 Transceivers are included with the Transceiver kits.

IN CASE OF DIFFICULTY

WARNING: When the line cord is connected to an AC outlet, AC voltage is present at several places on the chassis. Be careful you do not contact this voltage or an electrical shock can result.

1. Recheck the wiring. Trace each lead with a color pencil on the Pictorial as you check it. It is frequently helpful to have a friend check your work. Someone who is not familiar with the unit may notice something you have consistently overlooked.
2. About 90% of the kits that are returned for repair do not function properly due to poor connections and soldering. Therefore, you can eliminate many troubles by a careful inspection of the connections to make sure they are soldered as described in the "Soldering" section of the "Assembly Notes" on Page 6. Be sure all the wires are soldered at places where several wires are connected.
3. Be sure the transistors and the integrated circuit are in the proper locations (correct part number and type number). Be sure that each lead is in the correct hole and has a good solder connection to the foil.
4. Check capacitor values carefully. Be sure the proper part is wired into the circuit at each capacitor location. Check each electrolytic capacitor to be sure the lead near the positive (+) marking is at the correct position.
5. Check each resistor value carefully.
6. Be sure the correct diode is installed at each diode location, and the banded end is positioned correctly.
7. Check all component leads connected to the circuit board.
8. Make sure the bare wire ends do not touch the chassis or other lugs and make sure all wires are properly soldered.

In an extreme case where you are unable to resolve a difficulty, refer to the "Customer Service" information inside the rear cover of this Manual. Your Warranty is located inside the front cover.

Troubleshooting Chart

PROBLEM	POSSIBLE CAUSE
Voltage drops significantly when transmitting.	1. IC1. 2. Transistor Q1 and Q2.
Unable to obtain +13.8 VDC with Voltage Adjust control.	1. IC1. 2. Voltage Adjust control R4. 3. Resistors R3 or R5.
No output voltage.	1. IC1. 2. Transistor Q1 or Q2. 3. Transformer T1. 4. Capacitor C1 or C4.
Input fuse F1 blows.	1. Transformer T1. 2. Capacitor C1 or C4. 3. Diodes D1 through D4.
Output fuse F2 blows.	1. External load too large. 2. Output wires touching.
Pilot lamp not lit.	1. Lamp PL1. 2. Resistor R1.

SPECIFICATIONS

Output Voltage	13.8 VDC regulated. (Adjustable from approximately 12.5 to 14.5 VDC).
Output Current	2.7 amperes, 40% duty cycle at 13.8 VDC.
Regulation	Better than 1% from no load to full load (2.7 amperes).
Ripple	Less than 0.1%.
Transistor, Integrated Circuit, and Diode Complement	2N3055 pass transistor (1). MPSU05 driver transistor (1). UA78MGT4C IC voltage regulator (1). 1N2071 silicon diode (1). S-5A05 silicon diode (4).
Power Requirements	110 to 130 VAC or 220 to 260 VAC, 50/60 Hz, at 75 watts (full load).
Dimensions	3" high × 7-1/4" wide × 10" deep (including switch and feet). (7.6 × 18.4 × 25.4 cm.)
Net Weight	5 lbs (2.3 kg).

The Heath Company reserves the right to discontinue products and to change specifications at any time without incurring any obligation to incorporate new features in products previously sold.

CIRCUIT DESCRIPTION

Refer to the Schematic Diagram (Illustration Booklet, Page 4) while you read this "Circuit Description." Refer to the "Circuit Board X-Ray View" for the physical location of the parts on the circuit board.

The 120 VAC or 240 VAC line voltage is applied through fuse F1 and Power switch SW1 to the primary winding of power transformer T1. From the secondary winding, the voltage is applied to silicon diodes D1, D2, D3, and D4. These diodes operate as a full-wave bridge rectifier circuit. The rectified voltage is then filtered by electrolytic capacitor C1 before it is applied to the regulator circuitry.

Transistors Q1 and Q2 form a Darlington circuit which provides exceptionally high gain for excellent regulation. The conduction of the Darlington circuit and the output voltage is controlled by the base bias provided by integrated circuit IC1. IC1, with its own zener reference diode, samples the output voltage, compares this to the internal reference voltage, and

automatically adjusts the base bias of Q1 as needed to maintain a fixed output level under varying load conditions. The output voltage is sampled at the output of Q2. This allows almost no change in load voltage from no-load to full-load conditions.

The regulated output voltage output level is adjusted by Voltage Adjust control R4 on the circuit board.

Capacitor C2 provides a nearly pure DC voltage for integrated circuit regulator IC1. Diode D5 allows C2 to charge from the power path but does not allow it to discharge back. In this way, only the small load of IC1 is placed on C2. R2 prevents excessive current from flowing through D1 when the Power Supply is turned on.

Fuse F2 protects pass transistor Q2 against an overload. Resistor R6 is a bleeder resistor, and capacitors C3 and C4 provide transient protection.

CIRCUIT BOARD X-RAY VIEW

NOTE: To identify a part shown in this View, so you can order a replacement, proceed in either of the following ways:

1. A. Refer to the place where the part is installed in the Step-by-Step instructions and note the "description" of the part (for example: 22 k Ω , .1 μ F, or MPSU05).
- B. Look up this description in the "Parts List."
2. A. Note the identification number of the part (R-number, C-number, etc.).
- B. Locate the same identification number (next to the part) on the Schematic. The "description" of the part will also appear near the part.
- C. Look up this description in the "Parts List."

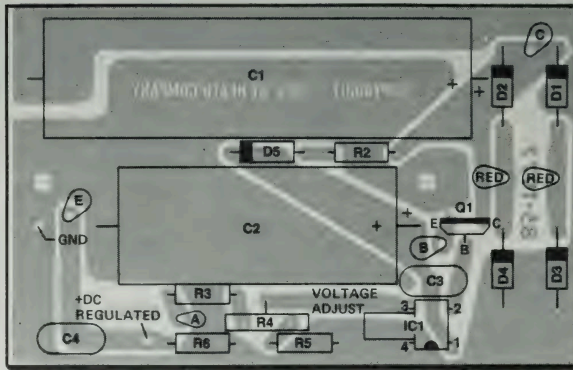

(Shown from component side)

SEMICONDUCTOR IDENTIFICATION CHART

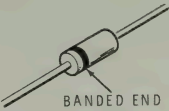
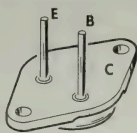
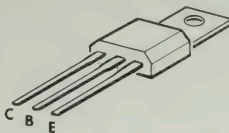
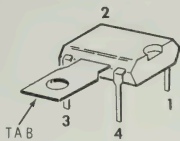
HEATH PART NUMBER	MAY BE REPLACED WITH	CIRCUIT COMPONENT NUMBER	IDENTIFICATION
57-27	1N2071	D5	 <p style="text-align: center;">BANDED END (CATHODE)</p>
57-71	S-5A05	D1, D2, D3, D4	
417-215	2N3055	Q2	
417-224	MPSU05	Q1	
442-626	UA78MGT4C	IC1	 <p style="text-align: right;"> 1. INPUT 2. OUTPUT 3. CONTROL 4. COMMON </p>

FOR PARTS REQUESTS ONLY

- Be sure to follow instructions carefully.
- Use a separate letter for all correspondence.
- Please allow 10 - 14 days for mail delivery time.

DO NOT WRITE IN THIS SPACE

INSTRUCTIONS

- Please print all information requested.
- Be sure you list the correct **HEATH** part number exactly as it appears in the parts list.
- If you wish to prepay your order, mail this card and your payment in an envelope. Be sure to include 10% (25¢ minimum, \$3.50 maximum) for insurance, shipping and handling. Michigan residents add 4% tax.
Total enclosed \$ _____
- If you prefer COD shipment, check the COD box and mail this card. COD

NAME _____
 ADDRESS _____
 CITY _____
 STATE _____ ZIP _____

The information requested in the next two lines is not required when purchasing nonwarranty replacement parts, but it can help us provide you with better products in the future.

Model # _____ Invoice # _____
 Date Purchased _____ Location Purchased _____

LIST HEATH PART NUMBER	QTY.	PRICE EACH	TOTAL PRICE

TOTAL FOR PARTS			
HANDLING AND SHIPPING			
MICHIGAN RESIDENTS ADD 4% TAX			
TOTAL AMOUNT OF ORDER			

SEND TO: **HEATH COMPANY**
 BENTON HARBOR
 MICHIGAN 49022
ATTN: PARTS REPLACEMENT

Phone (Replacement parts only): 616 982-3571

THIS FORM IS FOR U.S. CUSTOMERS ONLY
 OVERSEAS CUSTOMERS SEE YOUR DISTRIBUTOR

FOR PARTS REQUESTS ONLY

- Be sure to follow instructions carefully.
- Use a separate letter for all correspondence.
- Please allow 10 - 14 days for mail delivery time.

DO NOT WRITE IN THIS SPACE

INSTRUCTIONS

- Please print all information requested.
- Be sure you list the correct **HEATH** part number exactly as it appears in the parts list.
- If you wish to prepay your order, mail this card and your payment in an envelope. Be sure to include 10% (25¢ minimum, \$3.50 maximum) for insurance, shipping and handling. Michigan residents add 4% tax.
Total enclosed \$ _____
- If you prefer COD shipment, check the COD box and mail this card. COD

NAME _____
 ADDRESS _____
 CITY _____
 STATE _____ ZIP _____

The information requested in the next two lines is not required when purchasing nonwarranty replacement parts, but it can help us provide you with better products in the future.

Model # _____ Invoice # _____
 Date Purchased _____ Location Purchased _____

LIST HEATH PART NUMBER	QTY.	PRICE EACH	TOTAL PRICE

TOTAL FOR PARTS			
HANDLING AND SHIPPING			
MICHIGAN RESIDENTS ADD 4% TAX			
TOTAL AMOUNT OF ORDER			

SEND TO: **HEATH COMPANY**
 BENTON HARBOR
 MICHIGAN 49022
ATTN: PARTS REPLACEMENT

Phone (Replacement parts only): 616 982-3571

THIS FORM IS FOR U.S. CUSTOMERS ONLY
 OVERSEAS CUSTOMERS SEE YOUR DISTRIBUTOR

CUT ALONG DOTTED LINE

FOR PARTS REQUESTS ONLY

- Be sure to follow instructions carefully.
- Use a separate letter for all correspondence.
- Please allow 10 - 14 days for mail delivery time.

DO NOT WRITE IN THIS SPACE

INSTRUCTIONS

- Please print all information requested.
- Be sure you list the correct **HEATH** part number exactly as it appears in the parts list.
- If you wish to prepay your order, mail this card and your payment in an envelope. Be sure to include 10% (25¢ minimum, \$3.50 maximum) for insurance, shipping and handling. Michigan residents add 4% tax.
Total enclosed \$ _____
- If you prefer COD shipment, check the COD box and mail this card. COD

NAME _____
 ADDRESS _____
 CITY _____
 STATE _____ ZIP _____

The information requested in the next two lines is not required when purchasing nonwarranty replacement parts, but it can help us provide you with better products in the future.

Model # _____ Invoice # _____
 Date _____ Location _____
 Purchased _____ Purchased _____

LIST HEATH PART NUMBER	QTY.	PRICE EACH	TOTAL PRICE

TOTAL FOR PARTS	
HANDLING AND SHIPPING	
MICHIGAN RESIDENTS ADD 4% TAX	
TOTAL AMOUNT OF ORDER	

SEND TO: **HEATH COMPANY**
 BENTON HARBOR
 MICHIGAN 49022
ATTN: PARTS REPLACEMENT

Phone (Replacement parts only): 616 982-3571

FOR PARTS REQUESTS ONLY

- Be sure to follow instructions carefully.
- Use a separate letter for all correspondence.
- Please allow 10 - 14 days for mail delivery time.

DO NOT WRITE IN THIS SPACE

INSTRUCTIONS

- Please print all information requested.
- Be sure you list the correct **HEATH** part number exactly as it appears in the parts list.
- If you wish to prepay your order, mail this card and your payment in an envelope. Be sure to include 10% (25¢ minimum, \$3.50 maximum) for insurance, shipping and handling. Michigan residents add 4% tax.
Total enclosed \$ _____
- If you prefer COD shipment, check the COD box and mail this card. COD

NAME _____
 ADDRESS _____
 CITY _____
 STATE _____ ZIP _____

The information requested in the next two lines is not required when purchasing nonwarranty replacement parts, but it can help us provide you with better products in the future.

Model # _____ Invoice # _____
 Date _____ Location _____
 Purchased _____ Purchased _____

LIST HEATH PART NUMBER	QTY.	PRICE EACH	TOTAL PRICE

TOTAL FOR PARTS	
HANDLING AND SHIPPING	
MICHIGAN RESIDENTS ADD 4% TAX	
TOTAL AMOUNT OF ORDER	

SEND TO: **HEATH COMPANY**
 BENTON HARBOR
 MICHIGAN 49022
ATTN: PARTS REPLACEMENT

Phone (Replacement parts only): 616 982-3571

CUT ALONG DOTTED LINE

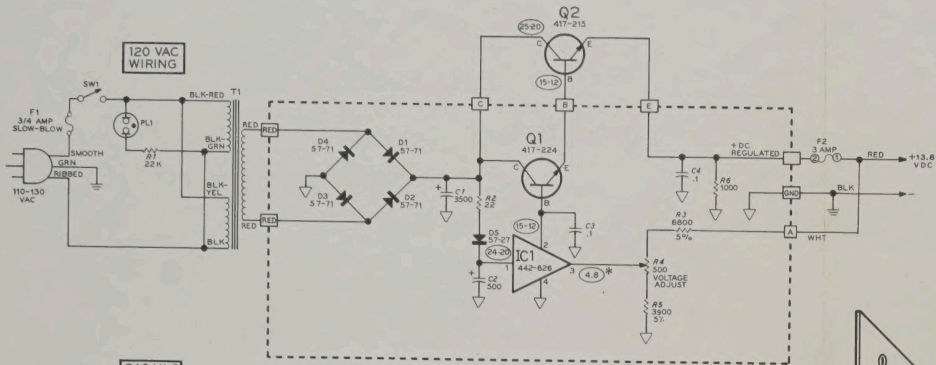

SCHEMATIC OF THE HEATHKIT® AC POWER SUPPLY MODEL HWA-2036-3

NOTES:

1. RESISTOR VALUES ARE IN OHMS. ALL RESISTORS ARE 1/2 WATT.
2. CAPACITOR VALUES ARE IN μ F.
3. THIS SYMBOL INDICATES A CONNECTION TO THE CIRCUIT BOARD.
4. THIS SYMBOL INDICATES DC VOLTAGES WITH 120 VAC SOURCE. VOLTAGES MAY VARY $\pm 20\%$. FIRST FIGURE IS TAKEN WITH NO LOAD. SECOND FIGURE IS TAKEN WITH 2.7A-LOAD.
5. * THIS VOLTAGE VARIES WITH THE SETTING OF CONTROL R4.

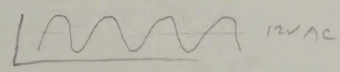
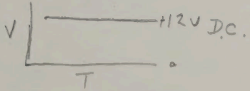

IC 1 FAIRCHILD 4A78MG

- 1 INPUT (+)
- 2 OUTPUT
- 3 CONTROL
- 4 COMMON

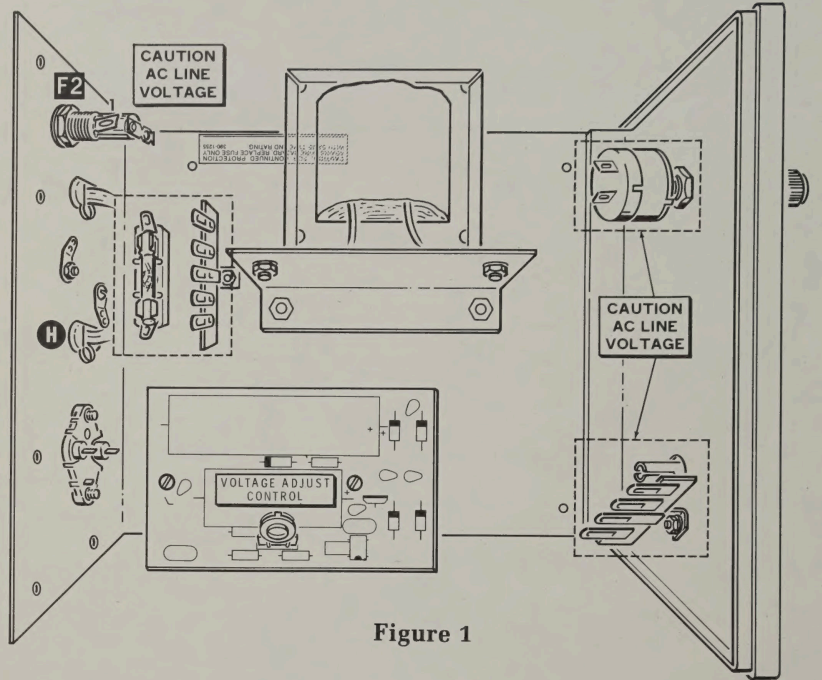
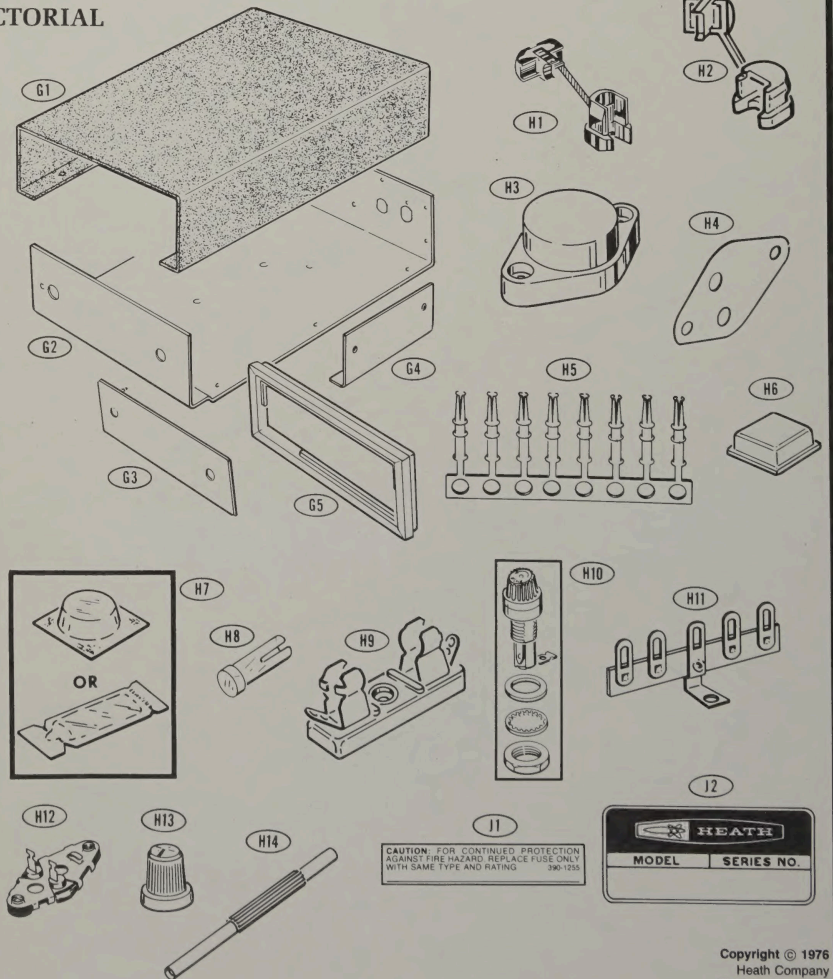
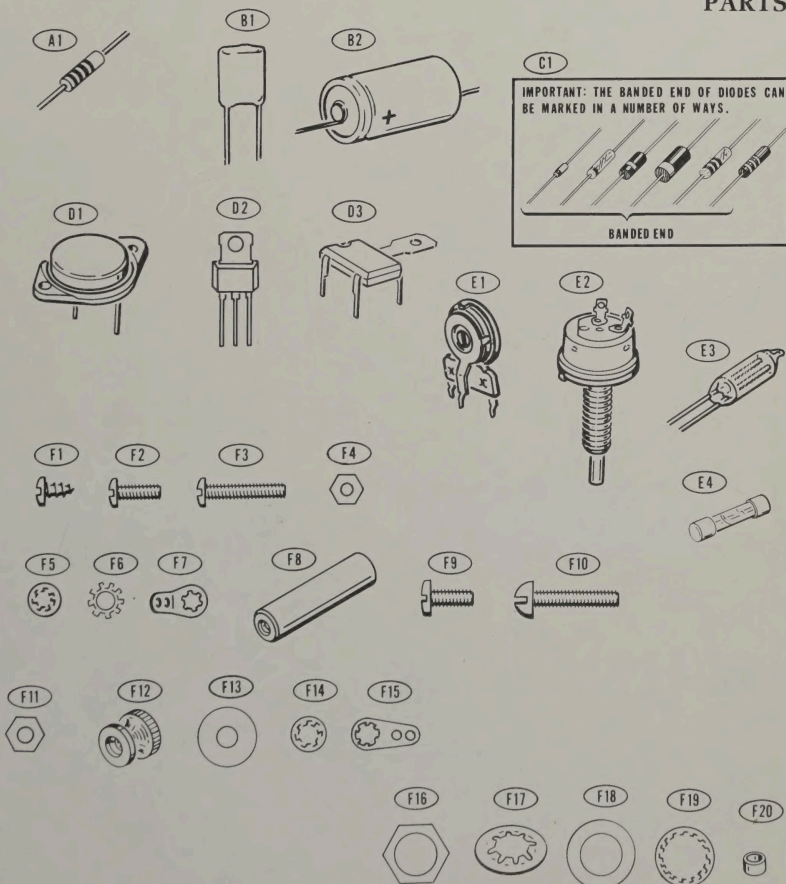

Figure 1

ILLUSTRATION BOOKLET

Part of 595-1943

PARTS PICTORIAL



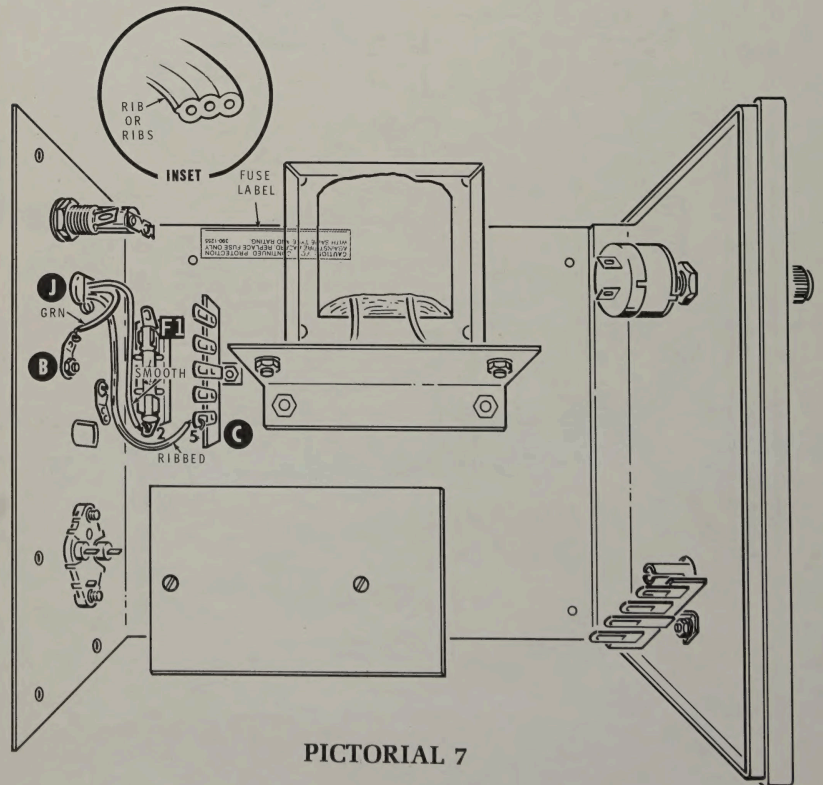
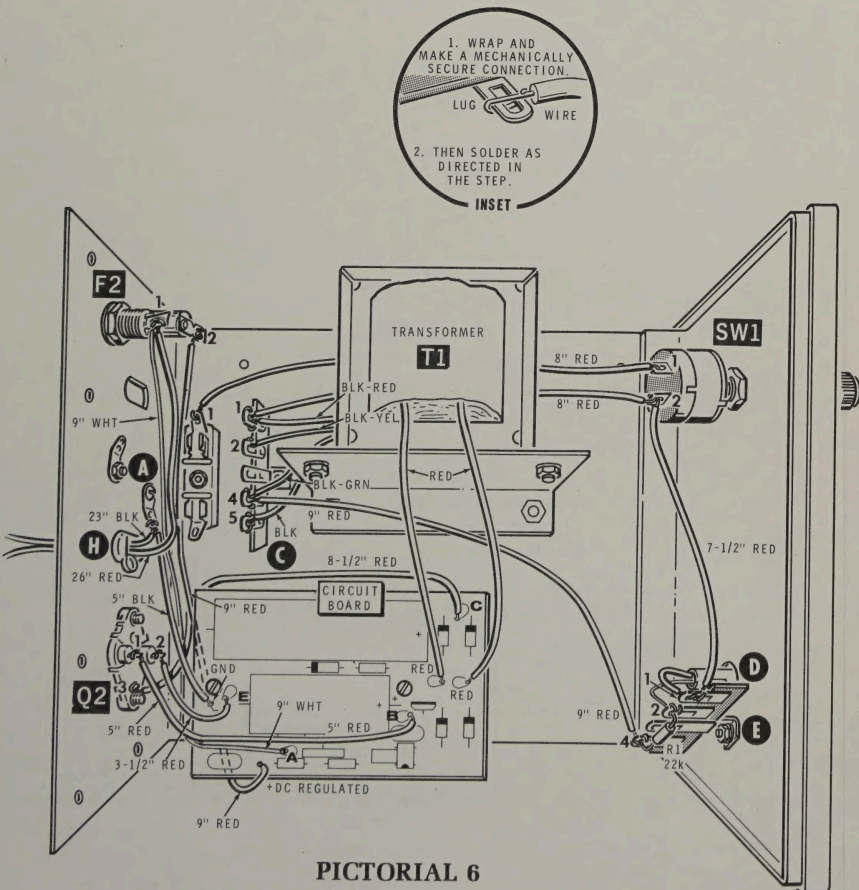
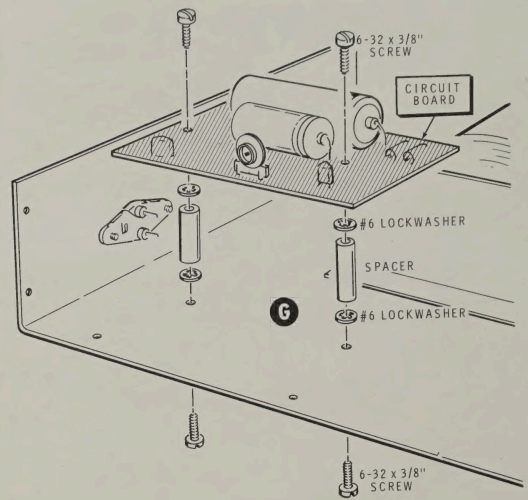
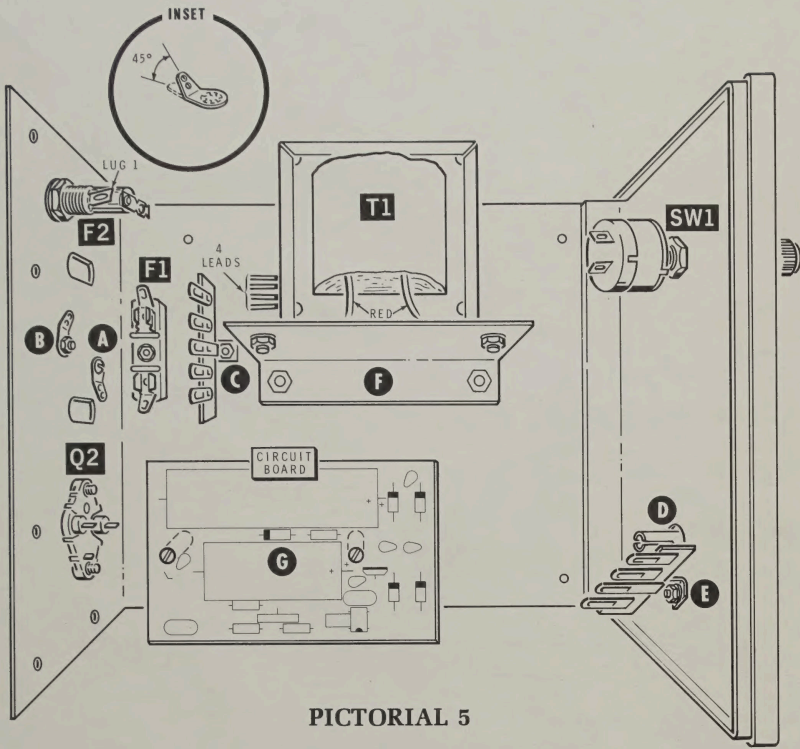

CUSTOMER SERVICE

REPLACEMENT PARTS

Please provide complete information when you request replacements from either the factory or Heath Electronic Centers. Be certain to include the **HEATH** part number exactly as it appears in the parts list.

Replacement parts are maintained specifically to repair Heath products. Parts sales for other reasons will be declined.

ORDERING FROM THE FACTORY

Print all of the information requested on the parts order form furnished with this product and mail it to Heath. For telephone orders (parts only) dial 616 982-3571. If you are unable to locate an order form, write us a letter or card including:

- Heath part number.
- Model number.
- Date of purchase.
- Location purchased or invoice number.
- Nature of the defect.
- Your payment or authorization for COD shipment of parts not covered by warranty.

Mail letters to: Heath Company
Benton Harbor
MI 49022
Attn: Parts Replacement

Retain original parts until you receive replacements. Parts that should be returned to the factory will be listed on your packing slip.

OBTAINING REPLACEMENTS FROM HEATH ELECTRONIC CENTERS

For your convenience, "over the counter" replacement parts are available from the Heath Electronic Centers listed in your catalog. Be sure to bring in the original part and purchase invoice when you request a warranty replacement from a Heath Electronic Center.

TECHNICAL CONSULTATION

Need help with your kit? — Self-Service? — Construction? — Operation? — Call or write for assistance, you'll find our Technical Consultants eager to help with just about any technical problem except "customizing" for unique applications.

The effectiveness of our consultation service depends on the information you furnish. Be sure to tell us:

- The Model number and Series number from the blue and white label.
- The date of purchase.
- An exact description of the difficulty.
- Everything you have done in attempting to correct the problem.

Also include switch positions, connections to other units, operating procedures, voltage readings, and any other information you think might be helpful.

Please do not send parts for testing, unless this is specifically requested by our Consultants.

Hints: Telephone traffic is lightest at midweek — please be sure your Manual and notes are on hand when you call.

Heathkit Electronic Center facilities are also available for telephone or "walk-in" personal assistance.

REPAIR SERVICE

Service facilities are available, if they are needed, to repair your completed kit. (Kits that have been modified, soldered with paste flux or acid core solder, cannot be accepted for repair.)

If it is convenient, personally deliver your kit to a Heathkit Electronic Center. For warranty parts replacement, supply a copy of the invoice or sales slip.

If you prefer to ship your kit to the factory, attach a letter containing the following information directly to the unit:

- Your name and address.
- Date of purchase and invoice number.
- Copies of all correspondence relevant to the service of the kit.
- A brief description of the difficulty.
- Authorization to return your kit COD for the service and shipping charges. (This will reduce the possibility of delay.)

Check the equipment to see that all screws and parts are secured. (Do not include any wooden cabinets or color television picture tubes, as these are easily damaged in shipment. Do not include the kit Manual.) Place the equipment in a strong carton with at least **THREE INCHES** of *resilient* packing material (shredded paper, excelsior, etc.) on all sides. Use additional packing material where there are protrusions (control sticks, large knobs, etc.). If the unit weighs over 15 lbs., place this carton in another one with 3/4" of packing material between the two.

Seal the carton with reinforced gummed tape, tie it with a strong cord, and mark it "Fragile" on at least two sides. Remember, the carrier will not accept liability for shipping damage if the unit is insufficiently packed. Ship by prepaid express, United Parcel Service, or insured Parcel Post to:

Heath Company
Service Department
Benton Harbor, Michigan 49022

HEATH

Schlumberger

HEATH COMPANY • BENTON HARBOR, MICHIGAN
THE WORLD'S FINEST ELECTRONIC EQUIPMENT IN KIT FORM

LITHO IN U.S.A.