

Heathkit® Manual

for the

SYNTHESIZED 2-METER FM TRANSCEIVER

Model HW-2036

595-1939-01

HEATH COMPANY
BENTON HARBOR, MICHIGAN 49022

Copyright © 1976
Heath Company
All Rights Reserved
Printed in the United States of America



TABLE OF CONTENTS

UNPACKING	3	Receiver Alignment	119
ASSEMBLY NOTES	4	Offset Oscillator Adjustment	121
CHASSIS ASSEMBLY		Deviation Adjustment	124
Parts List	7	Tone Adjustments	124
Step-by-Step Assembly	10	Micoder Adjustments	124
VCO CIRCUIT BOARD		FINAL ASSEMBLY	125
Parts List	26	INSTALLATION	
Step-by-Step-Assembly	28	Gimbal Bracket Installation	127
Installation	34	Fixed Station Installation	128
RECEIVER CIRCUIT BOARD		Mobile Station Installation	129
Parts List	40	Antennas	134
Step-by-Step Assembly	43	OPERATION	
Installation	55	Controls and Connections	135
SYNTHESIZER CIRCUIT BOARD		Power Supply	136
Parts List	56	Aux (Auxiliary) Crystal Information	136
Step-by-Step Assembly	59	Normal Operating Characteristics	137
Installation	68	IN CASE OF DIFFICULTY	
TRANSMITTER CIRCUIT BOARD		Visual Tests	138
Parts List	70	Precautions for Troubleshooting	139
Step-by-Step Assembly	73	Checking Transistors and Diodes	140
Installation	83	Troubleshooting Charts	141
POWER AMPLIFIER CIRCUIT BOARD		SPECIFICATIONS	143
Parts List	88	CIRCUIT DESCRIPTION	145
Step-by-Step Assembly	90	Synthesizer	146
Installation	105	Receiver	148
MICROPHONE INSTALLATION	108	Transmitter	148
INITIAL TESTS	110	Power Amplifier	149
Initial Test Troubleshooting Chart	111	CIRCUIT BOARD X-RAY VIEWS	150
ALIGNMENT		IDENTIFICATION CHARTS	153
Alignment Preparation	112	SCHEMATIC	Fold-in
VCO Adjustment	115	WARRANTY	Inside front cover
Transmitter Alignment	116	CUSTOMER SERVICE	Inside rear cover
10 MHz Oscillator Adjustment	117		
Power Amplifier Adjustment	118		

UNPACKING

The Transceiver shipping carton contains a box marked "Packs 1—5 TOP." There is also a container which has the Micoder® kit or a regular microphone in it, depending on which kit you purchased. After you remove these boxes, the remaining parts in the shipping carton form the Main Pack, which are items too large to fit into the other parts packs and those items which you will use in the chassis assembly section.

- () Set the box marked "Packs 1—5 TOP" aside until one of these packs is called for in an assembly section. DO NOT disturb any of these packs yet.
- () Set the Micoder kit or the regular microphone pack aside until it is called for.

Each assembly section of this Manual contains its own "Parts List" and "Step-by-Step Assembly" instructions. At the beginning of each "Parts List," you will be instructed which parts pack to remove from the box and open. You may also be directed to locate certain required parts from the Main Pack.

To avoid intermixing parts, do not remove or open any of these parts packs until you are directed to do so at the beginning of one of the "Parts Lists." Return any part that is packed in an individual envelope, with the part number on it, back in its envelope after you identify it until that part is called for in a step. Some envelopes have one transparent side so you can identify the parts inside without opening the envelope.

ASSEMBLY NOTES

TOOLS

You will need these tools to assemble your kit.

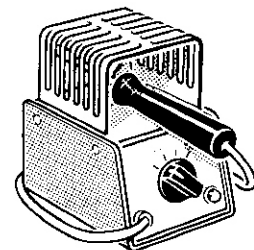
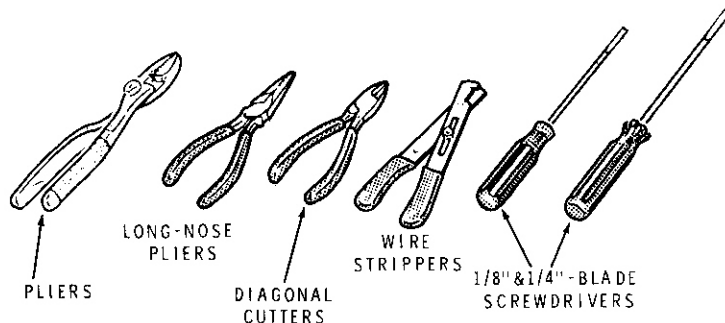

HEATHKIT
SOLDERING
IRON

OR

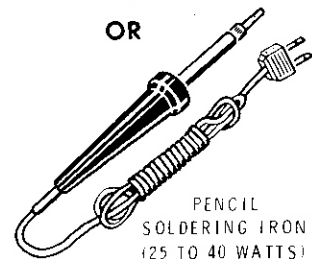

PENCIL
SOLDERING IRON
(25 TO 40 WATTS)

OTHER HELPFUL TOOLS

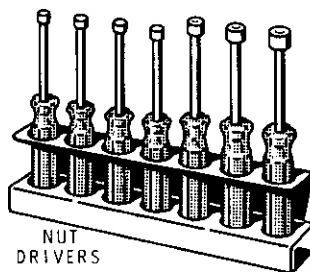
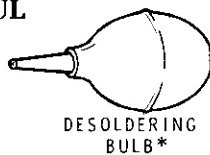

*TO REMOVE SOLDER FROM CIRCUIT CONNECTIONS.

ASSEMBLY

1. Follow the instructions carefully and read the entire step before you perform the operation.
2. The illustrations in the Manual are called Pictorials and Details. Pictorials show the overall operation for a group of assembly steps; Details generally illustrate a single step. When you are directed to refer to a certain Pictorial "for the following steps," continue using that Pictorial until you are referred to another Pictorial for another group of steps.
3. Most kits use a separate "Illustration Booklet" that contains illustrations (Pictorials, Details, etc.) that are too large for the Assembly Manual. Keep the "Illustration Booklet" with the Assembly Manual. The illustrations in it are arranged in Pictorial number sequence.
4. Position all parts as shown in the Pictorials.
5. Solder a part or a group of parts only when you are instructed to do so.



6. Each circuit part in an electronic kit has its own component number (R2, C4, etc.). Use these numbers when you want to identify the same part in the various sections of the Manual. These numbers, which are especially useful if a part has to be replaced, appear:

- In the Parts List,
- At the beginning of each step where a component is installed,
- In some illustrations,
- In the Schematic,
- In the section at the rear of the Manual.

7. When you are instructed to cut something to a particular length, use the scales (rulers) provided at the bottom of the Manual pages.

SAFETY WARNING: Avoid eye injury when you cut off excess lead lengths. Hold the leads so they cannot fly toward your eyes.

SOLDERING

Soldering is one of the most important operations you will perform while assembling your kit. A good solder connection will form an electrical connection between two parts, such as a component lead and a circuit board foil. A bad solder connection could prevent an otherwise well-assembled kit from operating properly.

It is easy to make a good solder connection if you follow a few simple rules:

1. Use the right type of soldering iron. A 25 to 40-watt pencil soldering iron with a 1/8" or 3/16" chisel or pyramid tip works best.
2. Keep the soldering iron tip clean. Wipe it often on a wet sponge or cloth; then apply solder to the tip to give the entire tip a wet look. This process is called tinning, and it will protect the tip and enable you to make good connections. When solder tends to "ball" or does not stick to the tip, the tip needs to be cleaned and retinned.

PARTS

Resistors will be called out by their resistance value in Ω (ohms), $k\Omega$ (kilohms), or $M\Omega$ (megohms). Certain types of resistors will have the value printed on the body, while others will be identified by a color code. The colors of the bands and the value will be given in the steps, therefore the following color code is given for information only.

EXAMPLES:

BROWN 1
GREEN 5
ORANGE 1,000
SILVER $\pm 10\%$

$15 \times 1,000 = 15,000 \Omega$ (15,000 OHMS),
or "15 $k\Omega$ "

ORANGE 3
BLACK 0
GREEN 100,000
GOLD $\pm 5\%$

$30 \times 100,000 = 3,000,000 \Omega$ (or 3 $M\Omega$)
3 $M\Omega = 3$ MEGOHMS

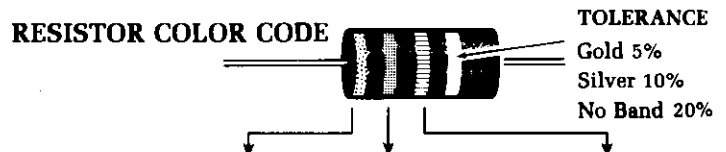
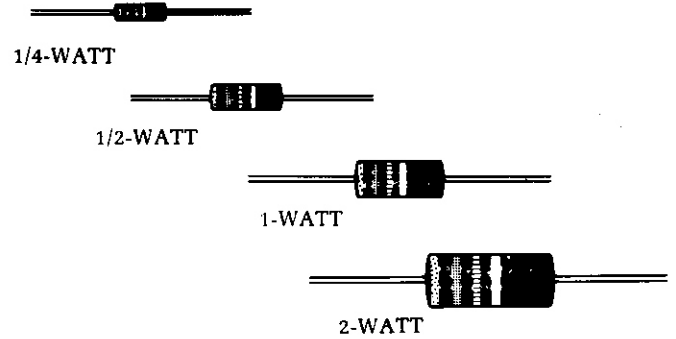

COLOR	1st DIGIT	2nd DIGIT	MULTIPLY BY
BLACK	0	0	1
BROWN	1	1	10
RED	2	2	100
ORANGE	3	3	1,000
YELLOW	4	4	10,000
GREEN	5	5	100,000
BLUE	6	6	1,000,000
VIOLET	7	7	10,000,000
GRAY	8	8	100,000,000
WHITE	9	9	1,000,000,000
GOLD			.1
SILVER			.01

Capacitors will be called out by their capacitance value in μF (microfarads) or pF (picofarads) and type: ceramic, Mylar*, electrolytic, etc. Some capacitors may have their value printed in the following manner:

EXAMPLES:

$151K = 15 \times 10 = 150 pF$
 $759 = 75 \times 0.1 = 7.5 pF$

NOTE: The letter "R" may be used at times to signify a decimal point; as in: $2R2 = 2.2 (pF \text{ or } \mu F)$.

First digit of capacitor's value: 1

Second digit of capacitor's value: 5

Multiplier: Multiply the first & second digits by the proper value from the Multiplier Chart.

To find the tolerance of the capacitor, look up this letter in the Tolerance columns.

MULTIPLIER		TOLERANCE OF CAPACITOR		
FOR THE NUMBER:	MULTIPLY BY:	10pF OR LESS	LETTER	OVER 10pF
0	1	$\pm 0.1 pF$	B	
1	10	$\pm 0.25 pF$	C	
2	100	$\pm 0.5 pF$	D	
3	1000	$\pm 1.0 pF$	F	$\pm 1\%$
4	10,000	$\pm 2.0 pF$	G	$\pm 2\%$
5	100,000		H	$\pm 3\%$
			J	$\pm 5\%$
8	0.01		K	$\pm 10\%$
9	0.1		M	$\pm 20\%$

*DuPont Registered Trademark



CHASSIS ASSEMBLY

PARTS LIST

- () Locate and remove all the parts from the main pack (parts left in the shipping carton). Be sure you have removed the packs from the carton as directed in the "Unpacking" section.
- () Unpack these parts and check each part against the following list. The key numbers correspond to the numbers on the "Chassis Parts Pictorial" (Illustration Booklet, Page 1). Set aside any remaining parts not called for in this Parts List. They will be called for later.

To order a replacement part, always include the PART NUMBER. Use the Parts Order Form furnished with this kit. If one is not available, see "Replacement Parts" inside the rear cover of this Manual. For price information, refer to the separate "Heath Parts Price List."

KEY No.	HEATH Part No.	QTY.	DESCRIPTION	CIRCUIT Comp. No.
---------	----------------	------	-------------	-------------------

RESISTORS — CAPACITORS

NOTE: The following resistors have a tolerance of 10% unless otherwise noted. 10% is indicated by a fourth color band of silver; 5% is indicated by a gold fourth band.

A1	1-45-12	1	22 k Ω , 1/4-watt (red-red-orange)	Test purposes
A2	1-62	1	51 Ω , 1/2-watt, 5% (green-brown-black)	Test purposes
A2	1-2	1	68 Ω , 1/2-watt (blue-gray-black)	R3
A3	1-20-2	2	100 Ω , 2-watt (brown-black-brown)	Test purposes
A4	21-140	3	.001 μ F ceramic	C2, Test purposes
A5	25-212	1	22 μ F tantalum	C1

KEY No.	HEATH Part No.	QTY.	DESCRIPTION	CIRCUIT Comp. No.
---------	----------------	------	-------------	-------------------

CONTROLS — SWITCHES

B1	10-227	1	2000 (2k) Ω control	R2
B2	19-179	1	10 k Ω control with switch	R1/SW1
B3	61-16	1	Toggle switch	SW6
B4	63-1289	2	Rotary switch	SW2, SW7
	100-1671	1	Lever switch set consists of:	
B5	63-1229	3	Lever switch	SW3, SW4, SW5
B6	255-710	1	Decimal spacer	
B7	440-22	2	End cap	



KEY No.	HEATH Part No.	QTY.	DESCRIPTION	CIRCUIT Comp. No.
---------	----------------	------	-------------	-------------------

METAL PARTS

C1	200-1302	1	Chassis	
C2	203-1650-2	1	Front panel	
C3	210-58	1	Bezel	
C4	204-1866-4	1	Gimbal plate	
C5	90-577-5	1	Cabinet	
C6	90-1213-1	1	Bottom cover	
C7	204-2003	2	Meter bracket	
C8	205-1609-2	1	Front subpanel	
C9	204-1865-4	1	Gimbal bracket	
C10	215-67	2	Heat sink	

HARDWARE

NOTE: Hardware packets are marked to show the size of the hardware they contain (HDW#4, HDW#6, etc.). You may have to open more than one packet in this pack to locate all of the hardware of any one (#6, for example) size.

#2 Hardware

D1	250-421	4	2-56 × 3/8" screw	
D2	266-868	2	2-56 × 2-1/4" stud	
D3	252-51	8	2-56 nut	
D4	254-26	8	#2 lockwasher	

#4 Hardware

E1	250-428	2	4-40 × 1/4" flat head screw	
E2	252-2	2	Large 4-40 nut	
E3	254-9	2	#4 lockwasher	

#6 Hardware

F1	250-138	9	6-32 × 3/16" screw	
F2	250-56	5	6-32 × 1/4" screw	
F3	250-432	6	6-32 × 5/16" truss head screw	
F4	250-237	2	#6 × 3/8" sheet metal screw	
F5	250-1242	11	6-32 × 1/2" flat head screw	
F6	250-162	1	6-32 × 1/2" screw	
F7	250-1158	3	6-32 × 3/4" stud	
F8	252-3	17	6-32 nut	
F9	254-6	6	#6 external tooth lockwasher	
F10	254-1	25	#6 lockwasher	
F11	253-89	1	#6 "D" washer	
F12	255-60	2	6-32 × 1-1/8" spacer	
F13	259-1	2	#6 solder lug	
F14	253-27	2	#6 flat washer	

KEY No.	HEATH Part No.	QTY.	DESCRIPTION	CIRCUIT Comp. No.
---------	----------------	------	-------------	-------------------

Hardware (cont'd.)**#10 Hardware**

G1	250-83	4	#10 × 1/2" sheet metal screw	
G2	250-1147	2	#10 thumbscrew	
G3	252-49	2	#10 thumbnut	
G4	253-19	2	#10 flat washer	

Other Hardware

H1	253-15	2	Fiber flat washer	
H2	259-24	3	#8 solder lugs	
H3	252-7	2	Control nut	
H4	252-39	2	1/4" nut	
H5	253-10	2	Control flat washer	
H6	253-91	2	1" cork washer	
H7	254-5	2	Control lockwasher	
H8	205-778	1	1" steel blade	

CONNECTORS

J1	432-790	3	Plastic sleeve	
J2	259-22	1	Spade lug	
J3	432-72	2	Male connector (large)	
J4	432-73	7	Female connector	
J5	432-120	75	PCB connector (9 extra)	
J6	432-121	4	Small PCB pin	
J7	432-137	1	Push-on connector	
J8	432-183	1	9-pin plug housing	
J9	432-720	1	Female connector housing	
J10	432-723	2	Male connector housing	
J11	432-854	9	Male connector (small)	
J12	438-4	1	Phono plug	
J13	438-46	1	Phono plug, 3/8" tip	
J14	490-112	1	Extractor tool	

OTHER ELECTRONIC PARTS

	134-987	1	Wire harness	
	401-181	1	Speaker	S1
K1	407-167	1	Meter	M1
K2	412-611	1	LED (red)	LED2
K2	412-617	1	LED (amber)	LED1
K3	412-82	1	Lamp assembly	PL1
K4	423-10	1	Fuseholder assembly	
K5	475-10	17	1.07 μH ferrite bead	
K6	56-26	1	1N191 diode (brown-white-brown)	Test purposes



KEY HEATH No. Part No.	QTY. DESCRIPTION	CIRCUIT Comp. No.	KEY HEATH No. Part No.	QTY. DESCRIPTION	CIRCUIT Comp. No.
---------------------------	------------------	----------------------	---------------------------	------------------	----------------------

WIRE — SLEEVING

340-2	2'	Bare wire
343-12	5'	Shielded cable
344-15	10'	Large black stranded wire
344-16	10'	Large red stranded wire
344-90	3'	Small black stranded wire
344-91	1-1/2'	Brown stranded wire
344-92	3'	Small red stranded wire
344-94	1-1/2'	Yellow stranded wire
344-98	2-1/2'	Gray stranded wire
346-1	6"	Small sleeving
346-20	6"	Large (heat shrinkable) sleeving
346-21	6"	Teflon* sleeving
346-35	4'	Medium (heat shrinkable) sleeving
348-2	3'	Magnet wire

MISCELLANEOUS

L1	73-3	1	Rubber grommet
	73-39	1'	Foam tape
	75-193	1	Bottom insulator paper (with hole in center)

*DuPont registered trademark

Miscellaneous (cont'd.)

	75-727	1	Top insulator paper
L2	207-4	1	Cable clamp
L3	260-16	1	Alligator clip
L4	260-89	2	LED grommet
L5	260-90	2	LED retainer
L6	261-29	8	Foot
L7	354-5	1	Cable tie
L8	431-62	1	3-lug terminal strip
L9	462-291	2	Large knob
L10	462-952	2	Small knob
L11	352-13	1	Silicone grease pod
L12	490-5	1	Nut starter
L13	431-49	1	11-lug terminal strip
	351-9	1	Epoxy
			Solder

Test
purposes**PRINTED MATERIAL**

M1	391-34	1	Blue and white label
M2	390-1302	1	FCC label
	597-260	1	Parts Order Form Manual (See Page 1 for part number.)
	490-185	1	Package of desoldering braid

STEP-BY-STEP ASSEMBLY

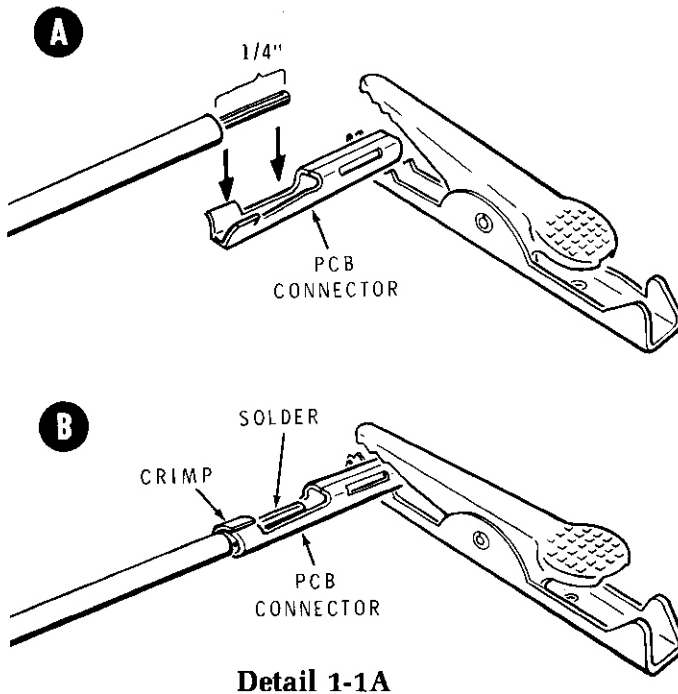

Detail 1-1A

HARNESS PREPARATION

Refer to Pictorial 1-1 (Illustration Booklet, Page 3) for the following steps.

- (✓) Locate and unfold the wire harness. Then bend the breakouts (marked BO 1 through BO 12 on the Pictorial) of the wire harness as shown. BO 1 has the two large orange wires and one large red wire.
- (✓) Refer to Detail 1-1A and install a PCB connector (#432-120) on the white-brown wire coming from BO 1 (breakout 1) of the wire harness. Use the alligator clip to hold the connector while you solder it. CAUTION: Do not allow solder to flow into the open end of the connector.

NOTES:

1. The wire harness contains several shielded cables. These cables have different colored bands on each end. In the following steps, these shielded cables will be called out by the band color.
 2. Always use a 1/2" length of small sleeving on the shield lead of a cable before you connect it. Refer to the inset on the Pictorial for identification of the shield lead.
- (✓) In the same way as before, install a PCB connector on each of the following wires at BO 1:

3 white-orange

red cable inner lead

red cable shield lead (and 1/2" of sleeving).

- (✓) Refer to Detail 1-1B and install a female connector (#432-73) on the red wire at BO 1. Then hold a plastic sleeve so the raised areas are positioned as shown and push the connector on the red wire into the sleeve until it locks.
- (✓) In the same way, install female connectors and plastic sleeves on the two orange wires at BO 1.
- () Cut six 5/8" lengths of medium (heat shrinkable) sleeving.



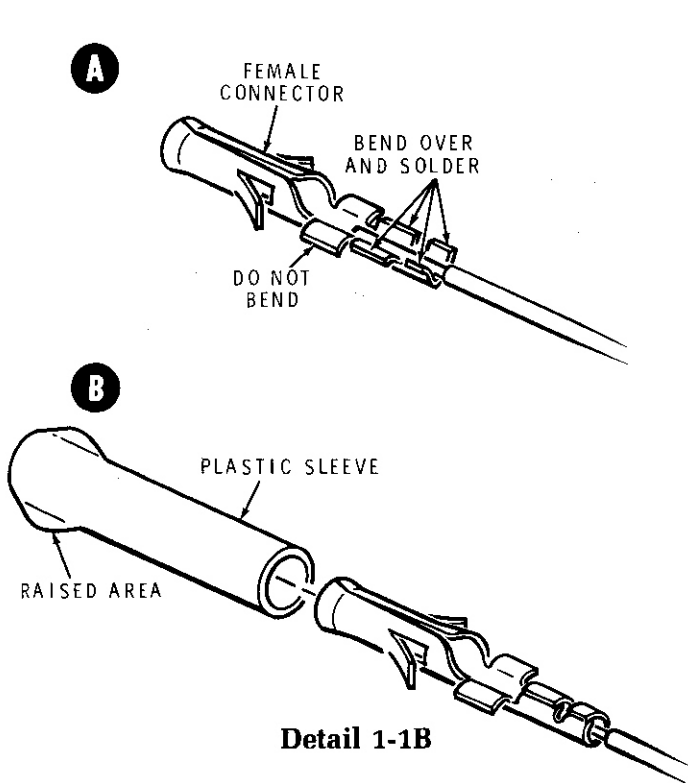

Detail 1-1B

NOTES:

- To install the medium sleeving on a PCB connector, push the sleeving onto the connector until the end of the sleeving is flush with the end of the connector. Then use the heat of a flame from a match, lighter, or candle to shrink the sleeving around the connector.
- You may wish to install all of the connectors, in the following steps, before you install the sleeving.

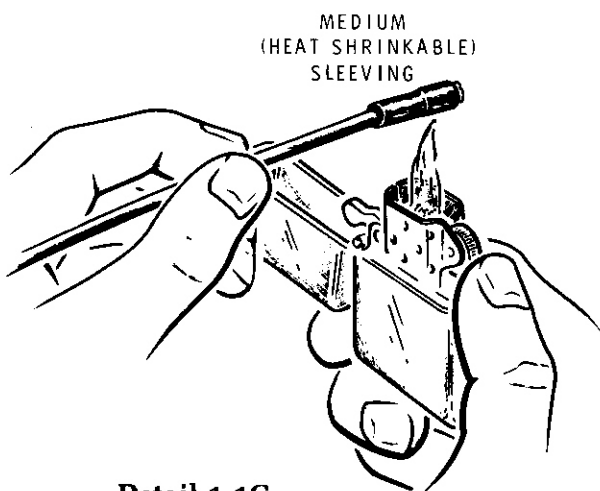

Detail 1-1C

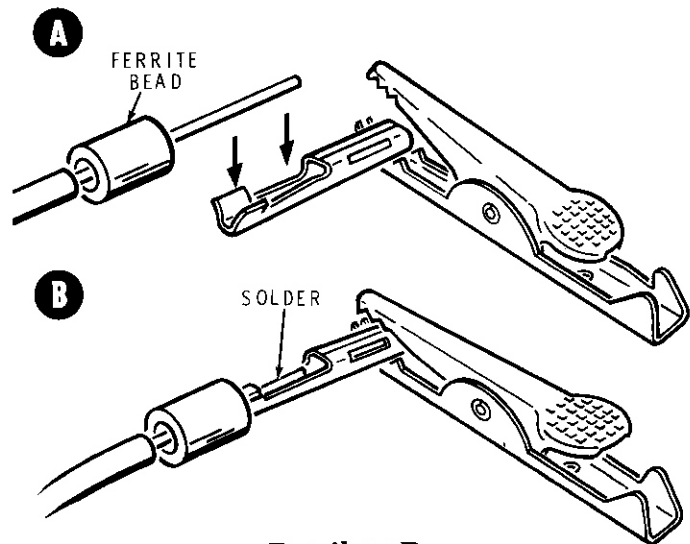

Detail 1-1D

- () Refer to Detail 1-1C and install a 5/8" length of medium sleeving on each PCB connector you installed on the wires coming from BO 1 of the wire harness.

NOTE: When a step directs you to install a ferrite bead and a PCB connector on a wire, as in the following step, first remove an additional 1/4" (total 1/2") of insulation from the wire. Then slide a ferrite bead onto the bare wire end and install the PCB connector as before. See Detail 1-1D.

- (✓) Locate the wires coming from BO 2 of the wire harness. Then install a ferrite bead and a PCB connector on the orange cable inner lead.
- (✓) Refer to inset drawing #2 on the Pictorial and install two ferrite beads, a PCB connector, and a .001 μ F ceramic capacitor on the red harness wire as follows:
 - Cut **one** lead of a .001 μ F ceramic capacitor to 7/8".
 - Wrap the red harness wire around the 7/8" capacitor lead close to the capacitor body. Then solder the connection.
 - Slide two ferrite beads onto the capacitor lead. Then install a PCB connector onto the end of the capacitor lead.
- (✓) Install **only** PCB connectors on the white-black wire and the orange cable shield lead.
- () Cut four 5/8" lengths of medium (heat shrinkable) sleeving.
- () Install a 5/8" length of medium sleeving on each PCB connector you installed on the wires coming from BO 2.

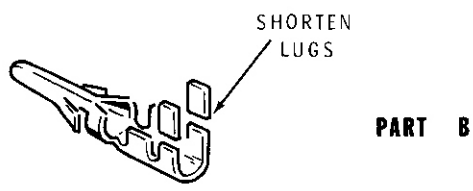
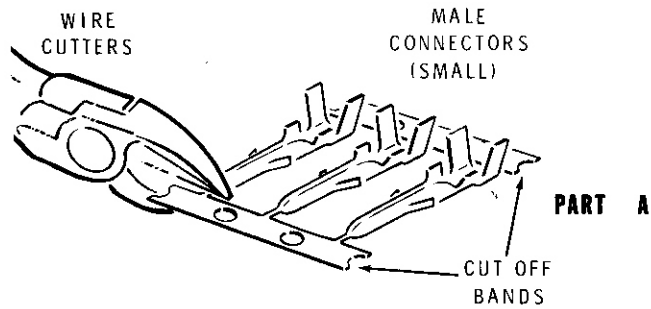

Detail 1-1E

NOTE: No connectors will be installed on the wires at BO 5, 6, 7, or 8.

(✓) Refer to Part A of Detail 1-1E and cut the two supporting bands from the strip of nine male connectors (small). Then refer to Part B and shorten the indicated lugs on each connector.

(✓) Locate the wires coming from BO 3 of the wire harness. Then refer to inset drawing #3 on the Pictorial and install a small male connector on each of the nine wires at this breakout.

(✓) Locate the wires coming from BO 4 of the wire harness. Then install ferrite beads and PCB connectors on these wires as follows:

- white-brown white-orange
- white-red white-black

(✓) Install only PCB connectors on the green cable inner and shield leads. Be sure to use 1/2" of small sleeving on the shield lead before you install the connector.

() Cut six 5/8" lengths of medium (heat shrinkable) sleeving.

() Install a 5/8" length of sleeving on each PCB connector you installed on the wires coming from BO 4.

(✓) Locate the wires coming from BO 9 of the wire harness. Then install a ferrite bead and a PCB connector on the orange cable inner lead.

(✓) Install only PCB connectors on the following wires coming from BO 9 (be sure to use 1/2" of small sleeving on each shield lead).

- red blue cable inner lead
- yellow blue cable shield lead
- brown
- white-red
- white-violet orange cable shield lead

() Cut nine 5/8" lengths of medium (heat shrinkable) sleeving.

() Install a 5/8" length of sleeving on each PCB connector you installed on the wires coming from BO 9.

(✓) Locate the wires coming from BO 10 of the wire harness. Then install only PCB connectors on these wires, as follows:

- white-orange red
- blue white-brown
- orange white-blue

() Cut six 5/8" lengths of medium (heat shrinkable) sleeving.

() Install a 5/8" length of sleeving on each PCB connector you installed on the wires coming from BO 10.

(✓) Locate the wires coming from BO 11 of the wire harness. Then install only PCB connectors on the green and violet wires.

(✓) Install ferrite beads and PCB connectors on the wires coming from BO 11 as follows:

- yellow red
- orange brown



- () Cut six 5/8" lengths of medium (heat shrinkable) sleeving.
- () Install a 5/8" length of sleeving on each PCB connector you installed on the wires coming from BO 11.
- (✓) Locate the wires coming from BO 12 of the wire harness. Then install only PCB connectors on these wires, as follows:

white	gray
black	white-black

- () Cut four 5/8" lengths of medium (heat shrinkable) sleeving.
- () Install a 5/8" length of sleeving on each PCB connector you installed on the wires coming from BO 12.

Refer to Pictorial 1-2 for the following steps.

- (✓) Position the 9-pin plug housing near BO 3 of the harness so the V-ridges inside the housing are at the top as shown. (The wires from BO 3 have the small male connectors soldered to them.)

NOTE: In the following steps, push each small male connector (on the wires coming from BO 3) into the indicated hole of the 9-pin plug housing until the connector snaps in place. Be careful to install each connector in the proper hole. They are very difficult to remove once they have been installed.

- (✓) White-red to hole 7.
- (✓) White-orange to hole 8.
- (✓) White to hole 9.
- (✓) Red to hole 4.
- (✓) White-yellow to hole 5.
- (✓) White-black to hole 6.
- (✓) White-brown to hole 1.

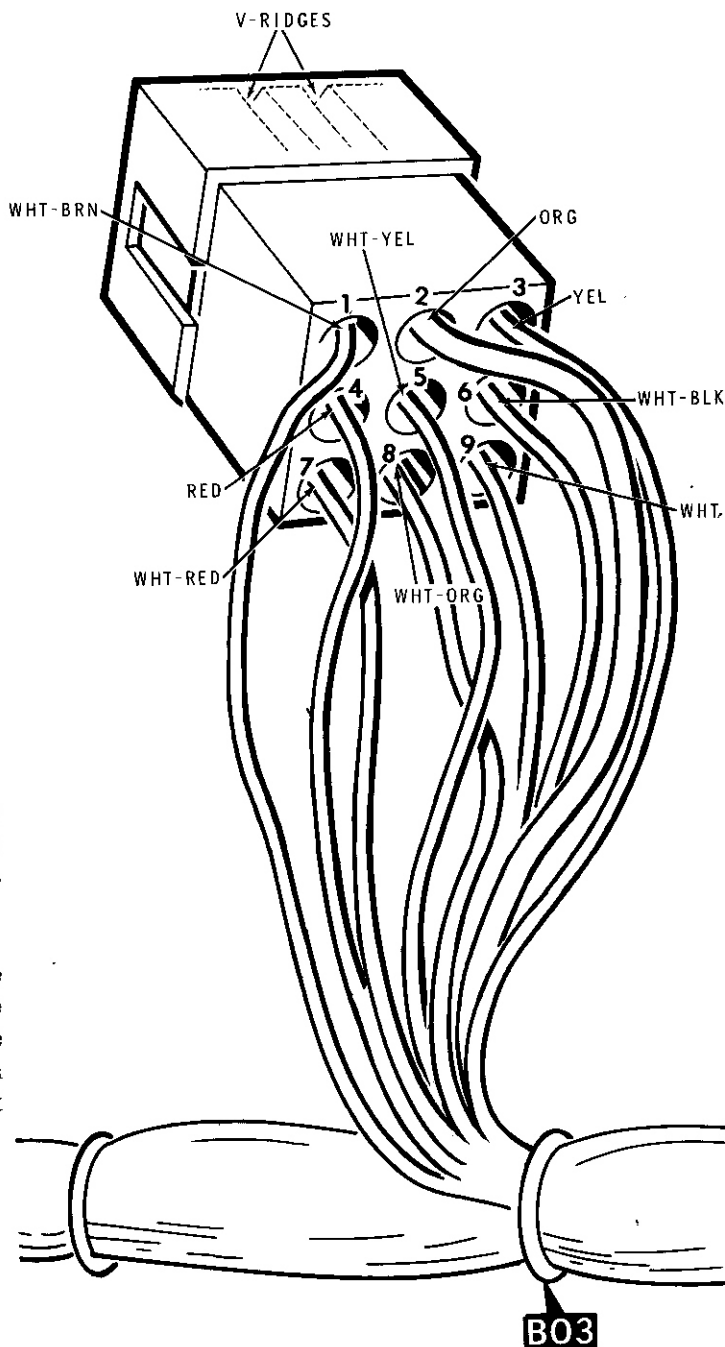

PICTORIAL 1-2

- (✓) Orange to hole 2.
- (✓) Yellow to hole 3.

Set the wire harness aside until it is called for.



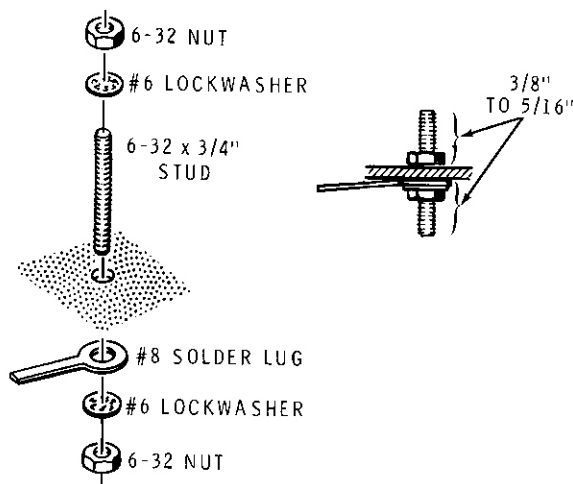

Detail 1-3A

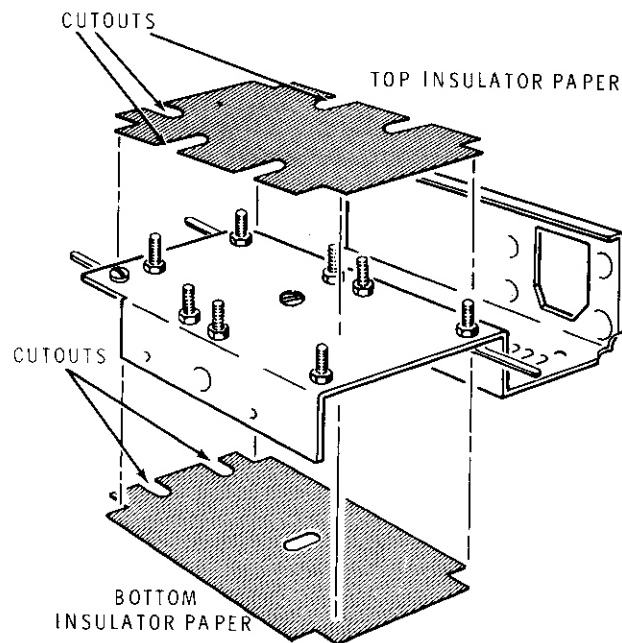

Detail 1-3B

CHASSIS PARTS MOUNTING

Refer to Pictorial 1-3 (Illustration Booklet, Page 4) for the following steps.

- (✓) Position the chassis as shown.
- (✓) Locate three #8 solder lugs. Then cut the slender part of each lug in half as shown.

NOTE: Use the plastic nut starter (supplied with this kit) to hold and start 4-40 and 6-32 nuts on screws.

- (✓) Mount a #8 solder lug at AA with a 6-32 × 1/2" screw, a #6 lockwasher, and a 6-32 nut. Make sure the screw is on top of the chassis. Position the solder lug as shown in the Pictorial.

NOTE: In the next three steps, be sure to install the lockwashers as shown in the Pictorial.

- (✓) Install a 6-32 × 1/2" flat head screw at AB with a #6 lockwasher, a #6 external tooth lockwasher, and a 6-32 nut. Make sure the nut is on top of the chassis.
- (✓) In the same way, install 6-32 × 1/2" flat head screws at AD, AE, AG, and AH. Make sure the nuts are on top of the chassis.
- (✓) Install a 6-32 × 1/2" flat head screw at AF with a #6 lockwasher, a #6 external tooth lockwasher, and a 6-32 nut. Make sure the screw head is on top of the chassis.

- (✓) Refer to Detail 1-3A and install a 6-32 × 3/4" stud at AC with a #8 solder lug, two #6 lockwashers, and two 6-32 nuts. Tighten the hardware so the stud is centered as shown. Position the solder lug as shown in the Pictorial.

- () In the same way, install 6-32 × 3/4" studs at AJ and AK. Use a #8 solder lug at AK only. Make sure the studs are centered properly and position the solder lug at AK as shown in the Pictorial. *page 17*

- (✓) Locate the piece of top insulator paper (the one without the center hole).

- (✓) Remove the protective backing paper from the top insulator paper. Then refer to Detail 1-3B; line up the ends of the insulator paper with the edges of the chassis, and press the paper in place on the top of the chassis. CAUTION: Do not let the insulator paper touch the chassis before you have it in position. The paper is very difficult to remove once it adheres to any surface.

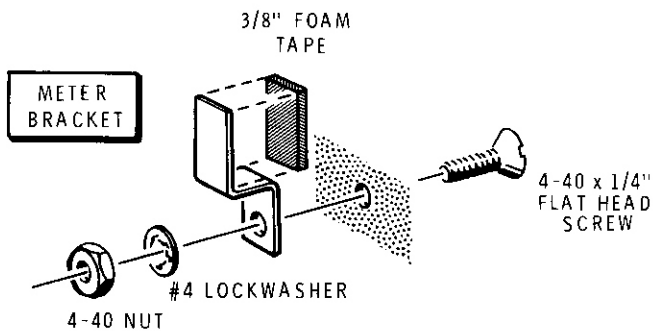

Detail 1-3C

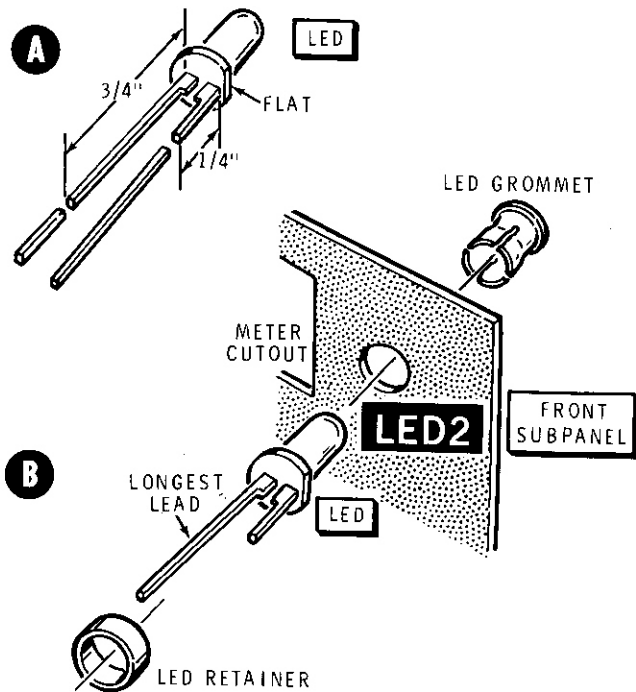

Detail 1-3D

- (✓) Turn the chassis over and, in the same way as before, install the bottom insulator paper on the bottom of the chassis as shown.
- (✓) Reposition the chassis as shown in the Pictorial.
- (✓) Locate the foam tape and two meter brackets.
- (✓) Cut two 3/8" lengths of foam tape.
- (✓) Refer to Detail 1-3C and remove the backing paper from a 3/8" length of foam tape. Then press the tape in place on a meter bracket as shown.
- () In the same way, install a 3/8" length of foam tape on the remaining meter bracket.
- () Install a meter bracket at AU with a 4-40 x 1/4" flat head screw, a #4 lockwasher, and a large 4-40 nut. Be sure to position the bracket as shown. Then tighten the hardware only finger tight.
- () In the same way, install a meter bracket at AW.
- (✓) Locate the front subpanel and the amber LED.

- (✓) Refer to Detail 1-3D, Part A, and cut the lead nearest the flat on the body of the amber LED to 1/4". Cut the other LED lead to 3/4".
- (✓) LED2: Refer to Detail 1-3D, Part B, and mount the amber LED in the front subpanel as follows:
 1. First insert the LED grommet into hole LED2 from the front of the panel.
 2. Push the LED into the grommet until the lip around the LED body slides into place in the grommet. Be sure the longest lead is closest to the meter cutout. NOTE: It may be helpful to slide a slender object into the grommet from the front of the panel and pry outward on the grommet lips (back of panel) just enough to permit the LED lip to slide into the grommet.
 3. Place the LED retainer over the LED leads and push it onto the end of the LED grommet which protrudes from the back of the panel. This locks the LED into place.



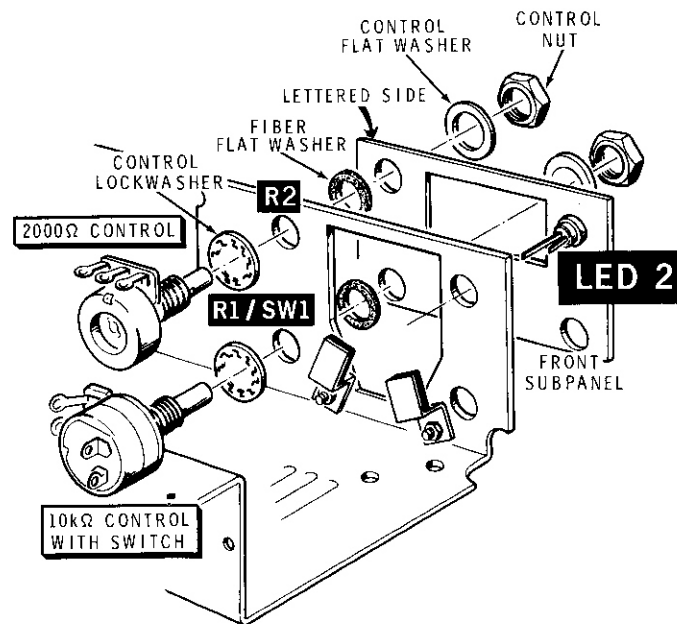

Detail 1-3E

(✓) R1/SW1, R2: Refer to Detail 1-3E and mount the front subpanel as follows:

1. Place a control lockwasher on the shaft of a 10 k Ω control with switch.
2. Insert the shaft of the control into hole R1/SW1 in the chassis. Then place a fiber flat washer on the shaft of the control.
3. In a similar way, place a control lockwasher on the shaft of a 2000 Ω (2k Ω) control. Then insert the shaft of the control into hole R2 in the chassis and place a fiber flat washer on the shaft of this control.
4. Place the front subpanel against the front of the chassis with the lettered side as shown. Be sure the shafts of the two controls and the leads from LED2 enter the indicated holes. Then secure the two controls with control flat washers and control nuts. Be sure the control lugs are positioned as shown.

(✓) Carefully unpack the meter and remove any wire that is connected between the meter lugs.

(✓) Refer to Detail 1-3F and bend the meter lugs up as shown.

NOTE: When you perform the next step, bend the meter brackets as necessary to firmly hold the meter.

(✓) M1: Install the meter at M1 as shown in Detail 1-3F as follows:

1. Make sure the meter brackets are positioned as shown.
2. Insert the meter in the front of the chassis as shown. Make sure the meter is seated in place.
3. Hold the meter in place and position the meter brackets behind the meter as necessary to hold it.
4. Tighten the hardware of each meter bracket. Use a small screwdriver.

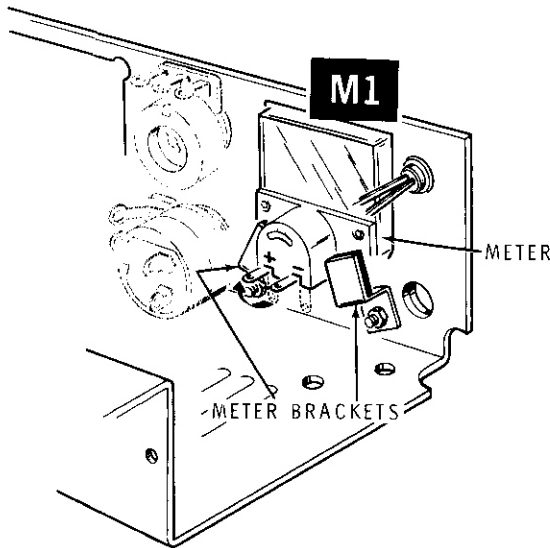

Detail 1-3F

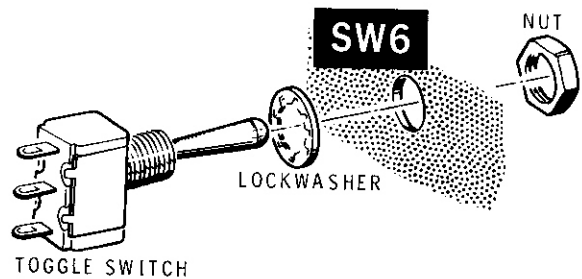

Detail 1-3H

- (✓) Refer to Detail 1-3G and install a 3-lug terminal strip at AT with a 6-32 × 1/4" screw, two #6 lockwashers, and a 6-32 nut. Position the terminal strip as shown.

NOTE: Do not overtighten the nut in the following step or you could damage the switch.

- (✓) SW6: Refer to Detail 1-3H and mount the toggle switch at SW6 as shown. Use the lockwasher and one of the nuts that is supplied with the switch. Save the remaining nut that was supplied with the switch for use later when you mount the front panel.

- (✓) SW7: Refer to Detail 1-3J and mount a rotary switch in hole SW7 in the chassis. Be sure to match the flat on the bushing of the switch with the flat in hole SW7. Then secure the switch with a 1/4" nut.

- (✓) SW2: In a similar way, mount another rotary switch at SW2 with a 1/4" nut.

- (✓) Locate a rubber grommet and cut through one side of it. Then install the grommet in slot AR so the cut side is toward the outside of the chassis as shown in the Pictorial.

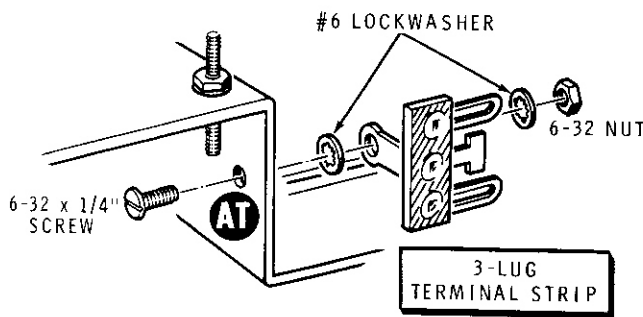

Detail 1-3G

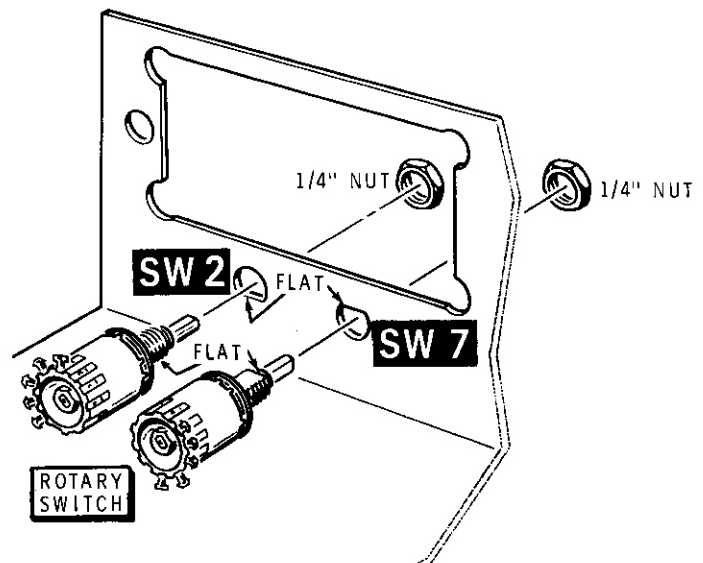

Detail 1-3J

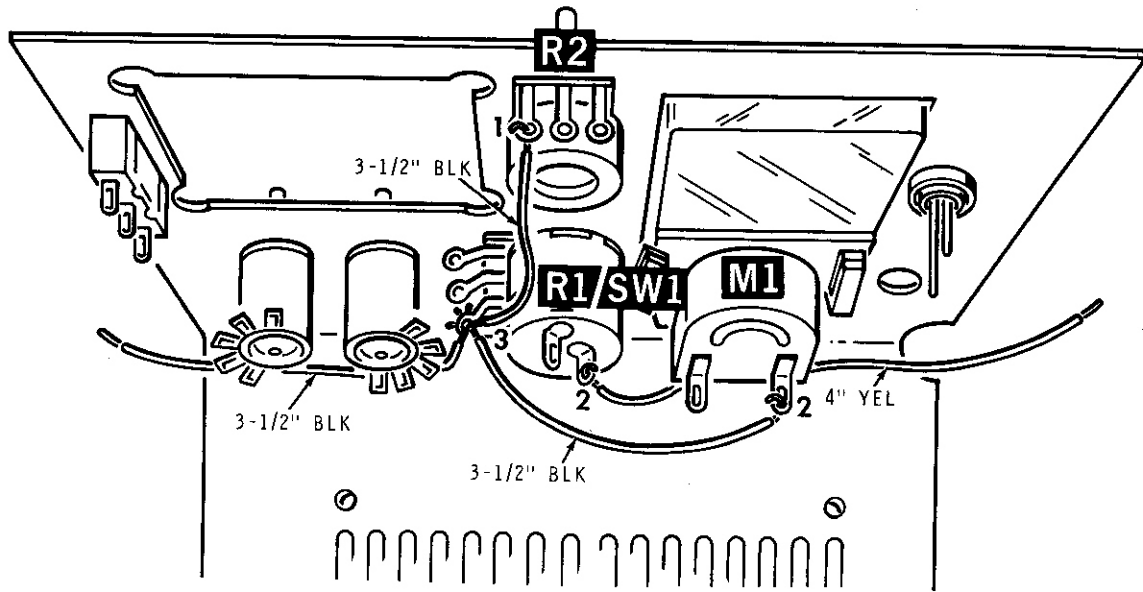

PICTORIAL1-4

CHASSIS PREWIRING

Refer to Pictorial 1-4 for the following steps.

NOTE: When you wire this kit, you will be instructed to prepare lengths of wire ahead of time, as in the following step. To prepare a wire, cut it to the indicated length and remove 1/4" of insulation from each end. Twist together the strands at each end and apply a small amount of solder to the wire ends to hold the fine strands together. The wires are listed in the order in which you will use them.

(✓) Prepare the following stranded wires:

QTY	LENGTH	COLOR
3	3-1/2"	small black
1	4"	yellow

NOTE: In the following steps, (NS) means not to solder because other wires will be added later. "S-" with a number, such as (S-3), means to solder the connection. The number following the "S" tells how many wires are at the connection.

- (✓) Connect a 3-1/2" small black stranded wire from control R2 lug 1 (S-1) to control R1 lug 3 (NS).
- (✓) Connect one end of another 3-1/2" small black stranded wire to control R1 lug 3 (NS). Route this wire under the rotary switches as shown. The other end will be connected later.
- (✓) Connect another 3-1/2" small black stranded wire from control R1 lug 3 (S-3) to meter M1 lug 2 (S-1).
- (✓) Connect a 4" yellow stranded wire to switch SW1 lug 2 (NS). Route this wire as shown; the other end will be connected later.





HARNESS WIRING

Refer to Pictorial 1-5 (Illustration Booklet, Page 4) for the following steps.

- (✓) Locate the harness and position it as shown.

NOTES:

1. You may find it helpful to remove the switches from the chassis while you wire them in the following steps.
2. Disregard any numbers stamped into the switch lugs.

Connect some of the wires coming from BO 5 as follows:

- (✓) White-orange wire to SW2 lug 1 (S-1).
- (✓) White-red wire to SW2 lug 2 (S-1).
- (✓) White-brown wire to SW2 lug 3 (S-1).

NOTE: SW2 lug 4 will not be used.

- (✓) White-black wire to SW2 lug 5 (S-1).
- (✓) Black wire to SW7 lug 5 (S-1).

- (✓) Brown wire to SW7 lug 4 (S-1).

- (✓) Red wire to SW7 lug 3 (S-1).

- (✓) Orange wire to SW7 lug 2 (S-1).

- (✓) Yellow wire to SW7 lug 1 (S-1).

The white-yellow wire will be connected later.

Connect the wires coming from BO 6 as follows:

- (✓) White-violet wire to control R1 lug 2 (S-1).

- (✓) Violet wire to control R1 lug 1 (S-1).

- (✓) Orange wire to switch SW1 lug 2 (S-2).

- (✓) Red wire to switch SW1 lug 1 (S-1).

- (✓) White-blue wire to control R2 lug 2 (S-1).

- (✓) Blue wire to control R2 lug 3 (S-1).

- (✓) Connect the green wire coming from BO 7 to meter M1 lug 1 (S-1).

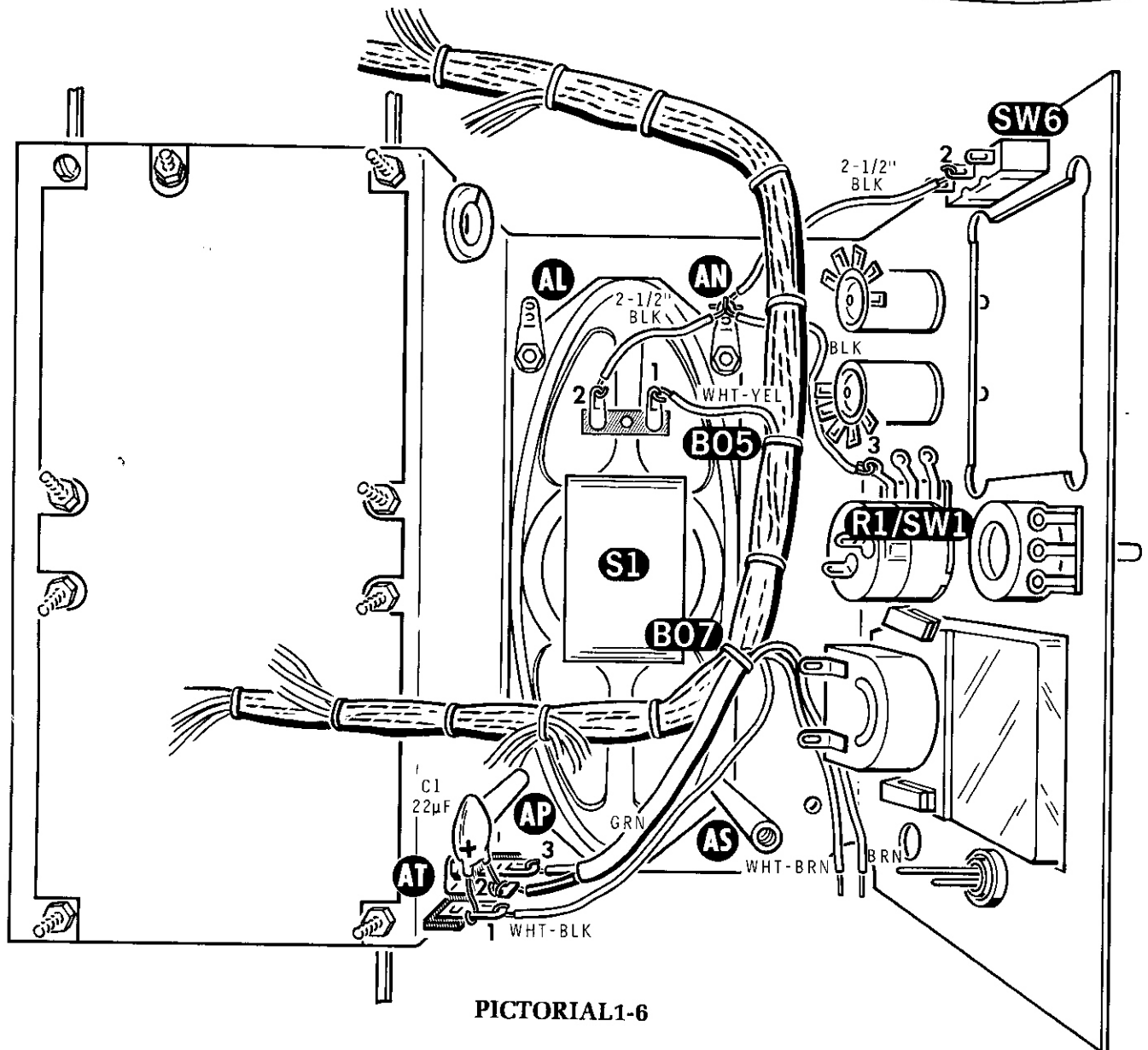

PICTORIAL1-6

Refer to Pictorial 1-6 for the following steps.

NOTE: When you mount the speaker in the following step, pull the harness up out of the way and be sure no wires are pinched between the speaker and the chassis.

(✓) S1: Refer to Detail 1-6A and mount the speaker as follows:

1. Place the speaker on the chassis so the speaker terminal strip is positioned as shown. Then line up the four mounting holes in the speaker with the holes in the chassis.

2. Mount the speaker at AL and AN with 6-32 × 1/2" flat head screws, #6 lockwashers, #6 solder lugs, and 6-32 nuts. Position the solder lugs as shown and tighten the hardware only finger tight.

3. Mount the speaker at AP and AS with 6-32 × 1/2" flat head screws, #6 flat washers, #6 lockwashers, and 6-32 × 1-1/8" spacers. Tighten the hardware only finger tight.

- (✓) Push the speaker as far forward (toward the controls) as possible. Then tighten the four 6-32 × 1/2" flat head screws that secure the speaker to the chassis.

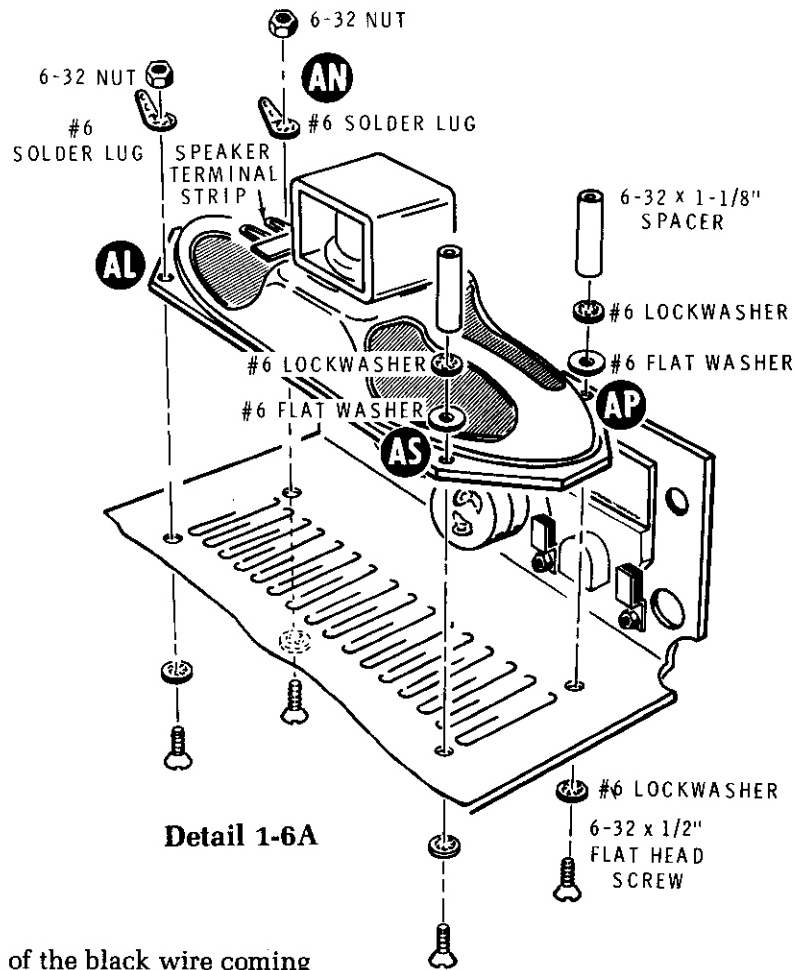

Detail 1-6A

- (✓) Connect the free end of the black wire coming from control R1 lug 3 to solder lug AN (NS).
- (✓) Connect the white-yellow wire coming from BO 5 of the wire harness to speaker S1 lug 1 (S-1).
- (✓) Prepare two 2-1/2" lengths of small black stranded wire.
- (✓) Connect a 2-1/2" small black stranded wire from switch SW6 lug 2 (S-1) to solder lug AN (NS).
- (✓) Connect another 2-1/2" small black stranded wire from speaker S1 lug 2 (S-1) to solder lug AN (NS).
- Connect some of the remaining wires coming from BO 7 of the wire harness as follows:
 - (✓) Green cable inner lead to terminal strip AT lug 3 (NS).
- (✓) Green cable shield lead to terminal strip AT lug 2 (NS). Be sure to use 1/2" of small sleeving on this lead.
- (✓) White-black wire to terminal strip AT lug 1 (NS).
- (✓) Route the brown and white-brown wires as shown. They will be connected later.
- (✓) C1: Connect the positive (+) or dot marked lead of a 22 μ F tantalum capacitor to terminal strip AT lug 1 (NS). Connect the other capacitor lead to lug 2 (NS).
- (✓) Push the wire harness back down into the chassis.

Temporarily set the chassis assembly aside.



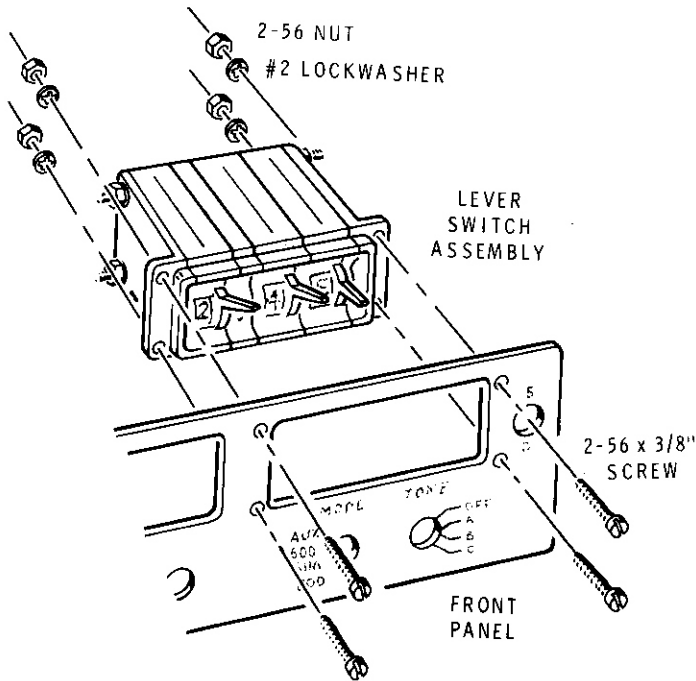

Detail 1-7B

FRONT PANEL ASSEMBLY

Refer to Pictorial 1-7 (Illustration Booklet, Page 5) for the following steps.

- (✓) Locate the lever switch set, two 2-56 × 2-1/4" studs, four #2 lockwashers, and four 2-56 nuts.

NOTE: If your lever switches are already assembled, check them against Detail 1-7A (Illustration Booklet, Page 5) for proper assembly; then skip the following step. You may discard the two 2-56 studs, four #2 lockwashers, and four 2-56 nuts that were supplied with your kit.

- (✓) Refer to Detail 1-7A (in the Illustration Booklet) and assemble the lever switch set with the 2-56 studs, #2 lockwashers, and 2-56 nuts as shown. Be sure to position each part as shown. **Do not overtighten the nuts.** Check the decimal spacer to make sure it is in the correct position.
- (✓) Locate the front panel, four 2-56 × 3/8" screws, four #2 lockwashers, and four 2-56 nuts.
- (✓) SW3, SW4, SW5: Refer to Detail 1-7B and mount the lever switch assembly on the front panel with 2-56 × 3/8" screws, #2 lockwashers, and 2-56 nuts. Be sure to position the switch assembly as shown. **Do not overtighten the nuts.**

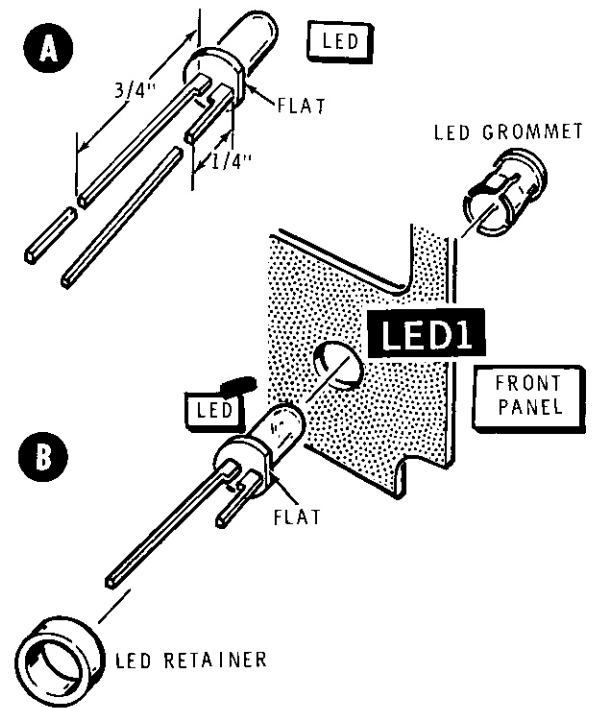

Detail 1-7C

- (✓) Refer to Detail 1-7C, Part A, and cut the lead nearest the flat on the body of the red LED to 1/4". Cut the other LED to 3/4".
- (✓) LED1: Refer to Detail 1-7C, Part B, and mount the red LED in the front panel as follows:
 1. First, insert the LED grommet into hole LED1 from the front of the panel.
 2. Push the LED into the grommet until the lip around the LED body slides into place in the grommet. Be sure the longest lead is positioned as shown in the Pictorial. **NOTE:** It may be helpful to slide a slender object into the grommet from the front of the panel and pry outward on the grommet lips (back of panel) just enough to permit the LED lip to slide into the grommet.
 3. Place the LED retainer over the LED leads and push it onto the end of the LED grommet which protrudes from the back of the panel. This locks the LED into place.



(✓) Prepare the following stranded wires:

QTY.	LENGTH	COLOR
3	2-3/8"	small brown
3	2-3/8"	small red
3	2-3/8"	small yellow
3	2-3/8"	small gray

(✓) Install PCB connectors on one end of each of the twelve wires you just prepared.

() Cut twelve 5/8" lengths of medium (heat shrinkable) sleeving.

() Install a 5/8" length of sleeving on each of the PCB connectors you just installed on the twelve wires.

Again, refer to Pictorial 1-7 for the following steps.

NOTES:

1. In the following steps, you will connect the twelve wires you just prepared to the lever switch assembly. Ignore any numbers that may be printed on the lever switch lugs.

2. It is only necessary to solder one side of each lever switch lug.

(✓) Position the front panel assembly as shown.

(✓) Connect a 2-3/8" brown wire to switch SW5 lug 4 (S-1).

(✓) Connect a 2-3/8" red wire to switch SW5 lug 3 (S-1).

(✓) Connect a 2-3/8" yellow wire to switch SW5 lug 2 (S-1).

(✓) Connect a 2-3/8" gray wire to switch SW5 lug 1 (S-1).

(✓) Connect a 2-3/8" brown wire to switch SW4 lug 4 (S-1).

(✓) Connect a 2-3/8" red wire to switch SW4 lug 3 (S-1).

(✓) Connect a 2-3/8" yellow wire to switch SW4 lug 2 (S-1).

(✓) Connect a 2-3/8" gray wire to switch SW4 lug 1 (S-1).

(✓) Connect a 2-3/8" brown wire to switch SW3 lug 4 (S-1).

(✓) Connect a 2-3/8" red wire to switch SW3 lug 3 (S-1).

(✓) Connect a 2-3/8" yellow wire to switch SW3 lug 2 (S-1).

(✓) Connect a 2-3/8" gray wire to switch SW3 lug 1 (S-1).

(✓) Cut a 3" length of small black stranded wire. Remove 1/4" of insulation from one end of the wire and 1-1/2" from the other end. Then prepare the wire ends as before.

NOTE: When a wire passes through a connection and goes to another point, it will be counted as two wires in the solder instructions (S-2), one entering and one leaving the connection.

(✓) Connect the 1-1/2" stripped end of the 3" small black stranded wire through switch SW5 lug 6 (S-2) and through switch SW4 lug 6 (S-2) to switch SW3 lug 6 (S-1). Cut off any excess bare wire end. The other end of this wire will be connected later.

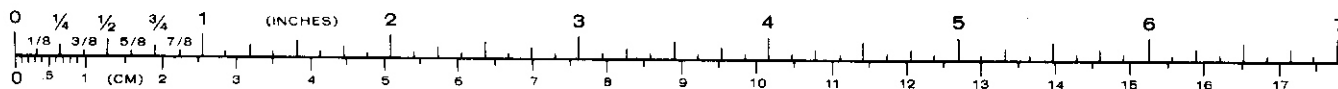

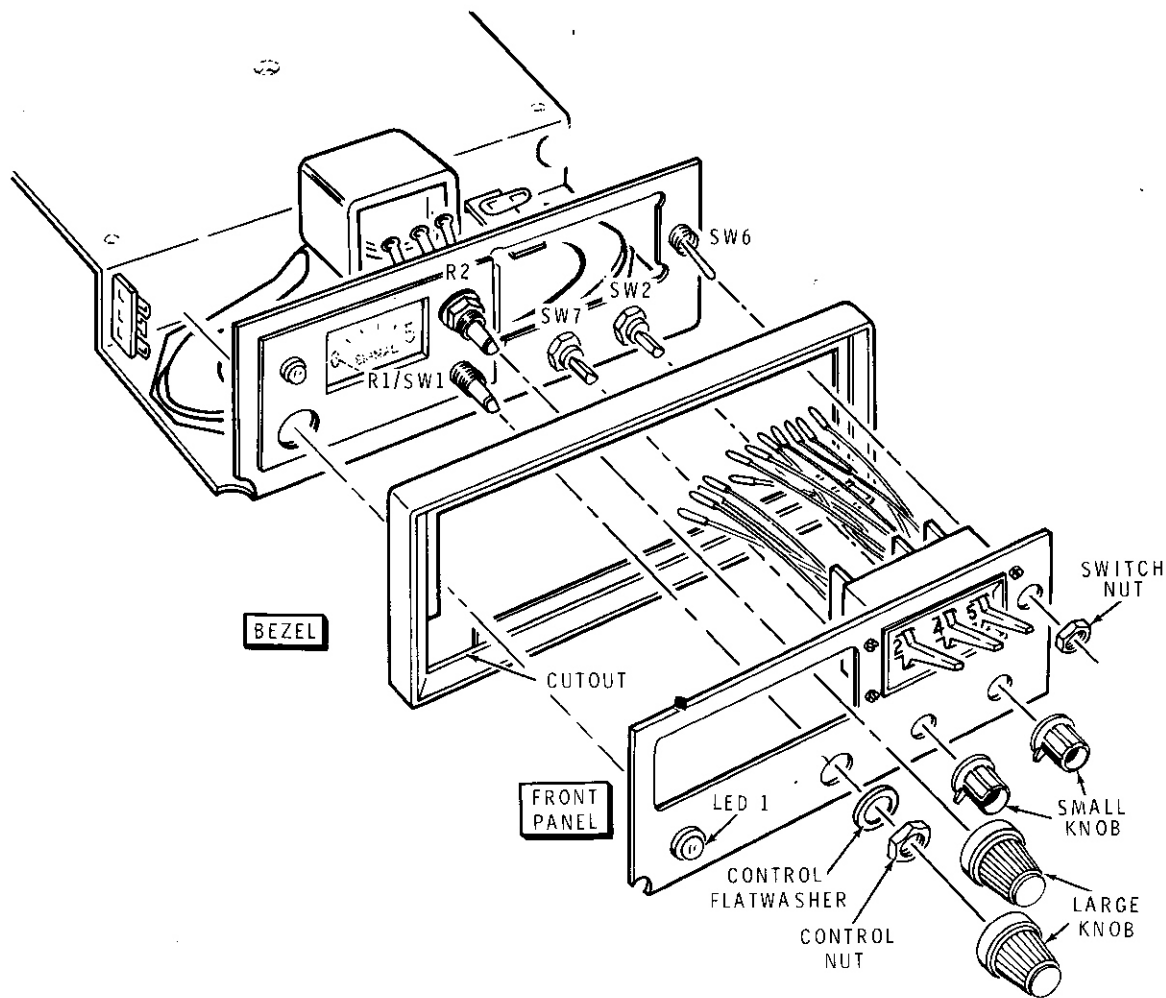

Detail 1-8A

FRONT PANEL INSTALLATION

Refer to Pictorial 1-8 (Illustration Booklet, Page 5) for the following steps.

- (✓) Position the chassis in front of you. Then remove the control nut and control flat washer from control R1/SW1.
- (✓) Locate the bezel and the nut you saved when you installed the toggle switch.

NOTE: When you perform the following step, position the harness under the lever switch assembly.

- (✓) Refer to Detail 1-8A and mount the bezel and front panel assembly on the chassis by reinstalling the control flat washer and control nut on control R1/SW1, and installing the switch nut on switch SW6. Be sure the leads from LED1 enter the indicated hole in the chassis. Also be sure to position the cutout in the bezel as shown. Do not overtighten the switch nut.
- (✓) Install a large knob on the shaft of R1/SW1. Line up the flat in the knob with the flat on the shaft; then push the knob onto the shaft as far as it will go.

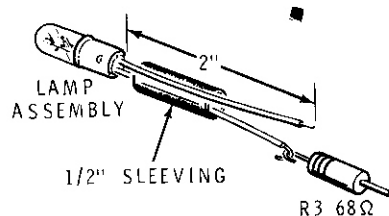

Detail 1-8B

- (✓) In the same way, install a large knob on the shaft of R2 and small knobs on the shafts of SW7 and SW2.
 - (✓) Connect the free end of the black wire coming from SW5 lug 6 to solder lug AN (S-4).
 - (✓) Push the wire harness into grommet AR between BO 4 and BO 5.
 - (✓) Push the end of a cable tie through a hole in solder lug AL. Then secure the harness as shown. Cut off any excess cable tie.
 - (✓) Bend LED1 lug 2 and LED2 lug 2 so they touch as shown in the Pictorial.
- NOTE: In the next three steps, wrap the bare wire end around the LED leads and solder it.
- (✓) Connect the white-brown wire coming from BO 7 of the wire harness to LED1 lead 1 (S-1).
 - (✓) Connect the yellow wire coming from R1/SW1 to LED1 lead 2 and LED2 lead 2 (NS).
 - (✓) Connect the brown wire coming from BO 7 of the wire harness to LED2 lead 1 (S-1).
- (✓) Locate the lamp assembly. Then cut the leads to 2", as shown in Detail 1-8B, and remove 1/4" of insulation from the end of each lamp lead.
 - () Slide 1/2" of medium (heat shrinkable) sleeving on one lamp lead. Then bend a small hook in the lead.
 - (✓) R3: Locate a 68 Ω, 1/2-watt (blue-gray-black) resistor. Then cut each resistor lead to 1/4".
 - (✓) Bend a small hook in one of the resistor leads. Then refer to Detail 1-8B and connect the hooks in the lamp lead and resistor lead together and solder them.
 - () Slide the sleeving on the lamp lead down over the resistor junction. Then use a flame to shrink the sleeving.
 - (✓) Connect the free lamp lead to the junction of the two LED leads and the yellow wire (S-4).
- NOTE: The other resistor lead will be connected later.
- Set the chassis aside until it is called for.



VCO CIRCUIT BOARD

PARTS LIST

- () Open the box marked "Packs 1—5 TOP."
- () Refer to the Pack Index Sheet and locate Pack #1.
- () Unpack these parts and check each part against the following list. The key numbers correspond to the numbers on the "VCO Circuit Board Parts Pictorial" (Illustration Booklet, Page 6).

To order a replacement part, always include the PART NUMBER. Use the Parts Order Form furnished with this kit. If one is not available, see "Replacement Parts" inside the rear cover of this Manual. For price information, refer to the separate "Heath Parts Price List."

KEY No.	HEATH Part No.	QTY.	DESCRIPTION	CIRCUIT Comp. No.	KEY No.	HEATH Part No.	QTY.	DESCRIPTION	CIRCUIT Comp. No.
RESISTORS, 1/4-Watt					CAPACITORS				
NOTE: The following resistors have a tolerance of 10% unless otherwise noted. 10% is indicated by a fourth color band of silver; 5% is indicated by a gold fourth band.									
A1	1-4-12	1	2200 Ω (red-red-red)	R502	B1	21-168	1	4.7 pF ceramic	C505
A1	1-74-12	5	3300 Ω , 5% (orange-orange-red)	R505, R506, R507, R508, R511	B2	20-174	1	42 pF mica	C509
A1	1-9-12	3	10 k Ω (brown-black-orange)	R501, R504, R509	B2	20-185	1	240 pF mica	C513
A1	1-32-12	1	100 k Ω (brown-black-yellow)	R503	B3	21-145	7	.001 μ F feedthrough (2 extra)	C514, C515, C516, C518, C519
					B1	21-176	1	.01 μ F ceramic	C512
					B1	21-192	2	.1 μ F ceramic	C503, C506
					B4	25-255	1	.22 μ F tantalum	C507
					B5	25-200	4	.68 μ F tantalum	C501, C502, C504, C508
					B6	31-57	1	2.7-20 pF trimmer	C511



KEY No.	HEATH Part No.	QTY.	DESCRIPTION	CIRCUIT Comp. No.
---------	----------------	------	-------------	-------------------

DIODES

C1	56-77	1	FV1010	VD501
C2	56-642	1	MV2107	VD502

TRANSISTORS — INTEGRATED CIRCUITS (IC's)

NOTE: Transistors and integrated circuits may be marked for identification in any of the following four ways:

1. Part number.
2. Type number. (On integrated circuits, this refers only to the numbers; the letters may be different or missing.)
3. Part number and type number.
4. Part number with a type number other than the one listed.

D1	417-801	2	MPSA20 transistor	Q501, Q503
D1	417-865	1	MPSA55 transistor	Q504
D1	417-134	1	MPS6520 transistor	Q502
D1	442-627	1	78L05 IC	IC501
D2	443-740	1	MC1648P IC	IC502

HARDWARE**#4 Hardware**

E1	250-489	2	4-40 × 3/16" self-tapping screw
E2	250-34	2	4-40 × 1/2" screw
E3	252-2	4	4-40 nut
E4	253-80	2	#4 flat washer
E5	254-9	6	#4 lockwasher

KEY No.	HEATH Part No.	QTY.	DESCRIPTION	CIRCUIT Comp. No.
---------	----------------	------	-------------	-------------------

Hardware (cont'd.)**Other Hardware**

F1	250-89	1	6-32 × 3/8" screw
F2	250-357	1	6-32 × 3/8" black nylon screw
F3	257-12	2	Eyelet
F4	259-6	4	Small solder lug
F5	260-65	1	Clip
F6	254-1	2	#6 lockwasher

MISCELLANEOUS

G1	40-1907	1	.165 μH coil (yellow)
G2	75-108	1	Paper insulator (2" × 1-3/4")
G3	206-1242	1	Top VCO shield
G4	206-1243	1	Bottom VCO shield
G5	351-9	1	Epoxy
G6	438-46	1	Phono plug, 3/8" tip

PART FROM THE MAIN PACK

85-1878-1	1	VCO circuit board
-----------	---	-------------------

STEP-BY-STEP ASSEMBLY

START

NOTE: In the following steps you will be given detailed instructions on how to install and solder the first part on a circuit board. Read and perform each step carefully. Then use the same procedure whenever you install parts on a circuit board.

- (✓) Position the circuit board as shown with the printed side up.

- (✓) R503: Hold a 100 kΩ (brown-black-yellow) resistor by the body as shown and bend the leads straight down.

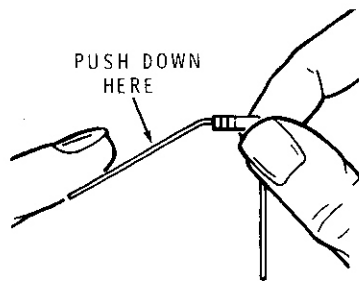

- (✓) Push the leads through the holes at the indicated location on the circuit board. The end with color bands may be positioned either way.

- (✓) Press the resistor against the circuit board. Then bend the leads outward slightly to hold the resistor in place.



CAUTION: This Transceiver operates in the vhf region. Therefore, as you build this kit, be sure you make perfect solder connections. Work carefully. Do not use excessive amounts of solder, cut off all leads and lugs close to the circuit board.

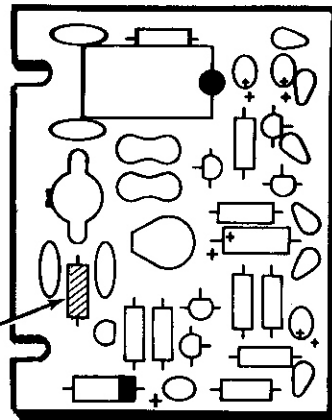

CONTINUE

- (✓) Solder the resistor leads to the circuit board as follows:

1. Push the soldering iron tip against both the lead and the circuit board foil. Heat both for 2 or 3 seconds.

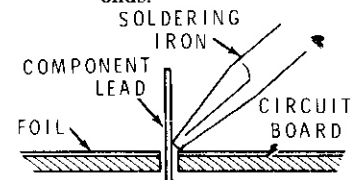

2. Then apply solder to the other side of the connection. IMPORTANT: Let the heated lead and the circuit board foil melt the solder.

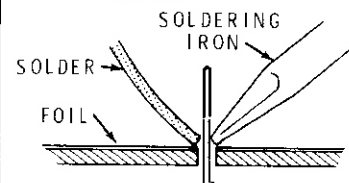

3. As the solder begins to melt, allow it to flow around the connection. Then remove the solder and the iron and let the connection cool.

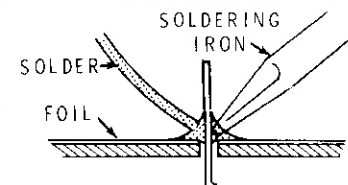

- () Cut off the excess lead length close to the connection. CAUTION: Hold the lead with one hand to prevent the lead from hitting you in the eye.

- () Check the connection. Compare it to the illustrations on the next page. After you have checked the solder connections, proceed with the assembly on Page 30. Use the same soldering procedure for each connection.

A GOOD SOLDER CONNECTION

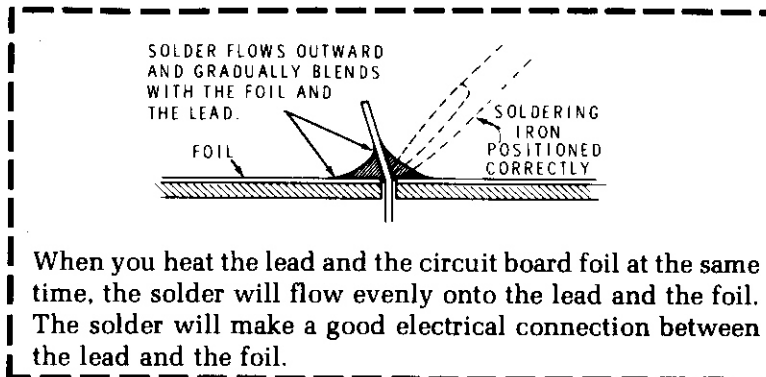

POOR SOLDER CONNECTIONS

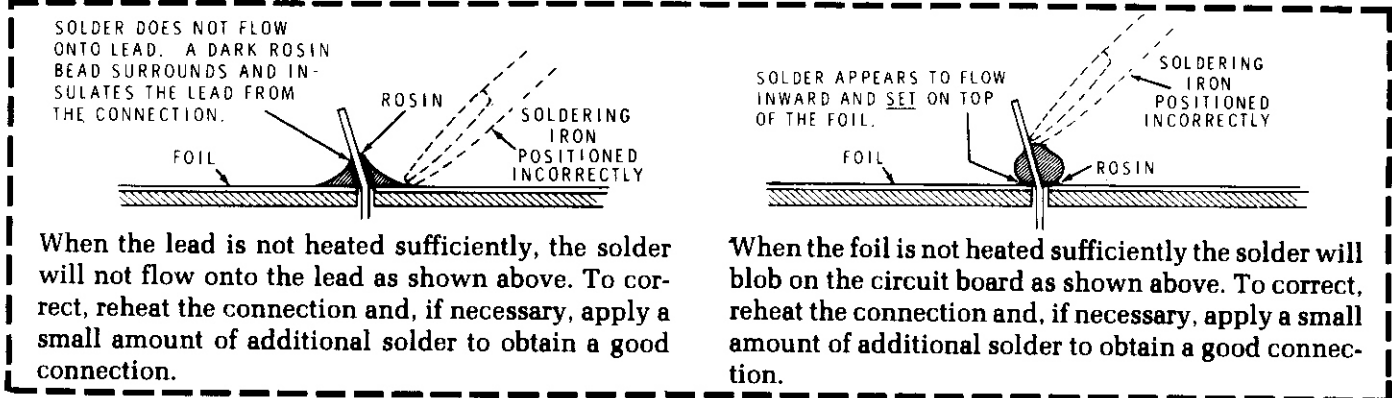

SOLDER BRIDGES

A solder bridge between two adjacent foils is shown in photograph A. Photograph B shows how the connection should appear. A solder bridge may occur if you accidentally touch an adjacent previously soldered connection, if you use too much solder, or if you "drag" the soldering iron across other foils as you remove it from the connection. A good rule to follow is; always take a good look at the foil area around each lead before you solder it. Then, when you solder the connection, make sure the solder remains in this area and does not bridge to another foil. This is especially important when the foils are small and close together. NOTE: It is alright for solder to bridge two connections on the same foil.

Use only enough solder to make a good connection, and lift the soldering iron straight up from the circuit board. If a solder bridge should develop, turn the circuit board foil-side-down and heat the solder between connections. The excess solder will run onto the tip of the soldering iron, and this will remove the solder bridge. NOTE: The foil side of each circuit board has a coating on it called "solder resist." This is a protective insulation to help prevent solder bridges.

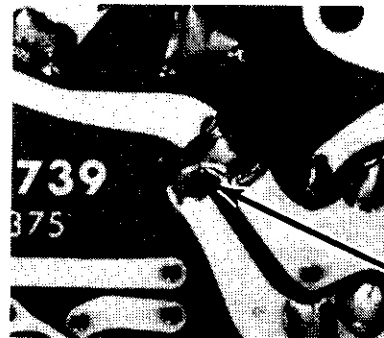

SOLDER BRIDGE



START →

(✓) **NOTE:** The indexed (pin 1) end of inline integrated circuits may be marked in a number of ways such as a notch, triangle, dot, the numeral 1, etc.

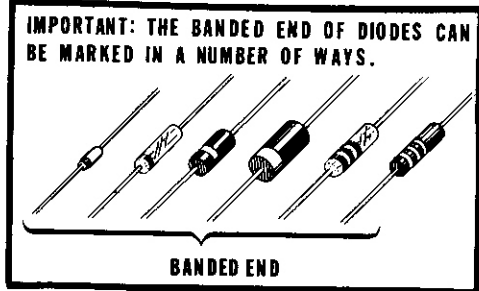
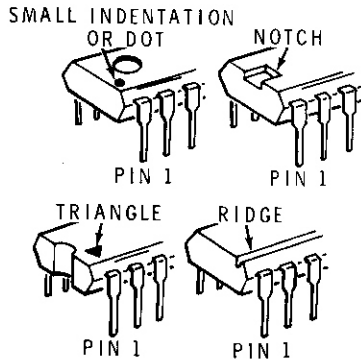

Detail 2-2A

(✓) **IC502:** MC1648P integrated circuit (#443-740). Position the pin 1 end of the IC over the index mark on the circuit board as shown. Then insert the pins into the circuit board and solder them to the foil. Do not solder the leads that do not have foil.

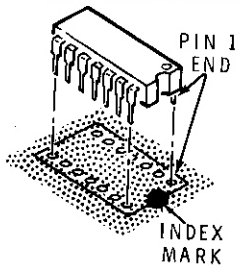

NOTE: When you install a diode, always match the band on the diode with the band mark on the circuit board. A DIODE WILL NOT WORK IF INSTALLED BACKWARDS. See Detail 2-2A.

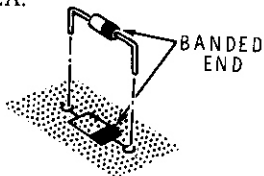

(✓) **VD501:** FV1010 diode (#56-77). Solder the leads to the foil and cut off the excess lead lengths.

CONTINUE →

- (✓) R511: 3300 Ω (orange-orange-red).
- (✓) R502: 2200 Ω (red-red-red).
- (✓) R504: 10 kΩ (brown-black-orange).
- (✓) R506: 3300 Ω (orange-orange-red).
- (✓) R505: 3300 Ω (orange-orange-red).
- (✓) R507: 3300 Ω (orange-orange-red).
- (✓) R501: 10 kΩ (brown-black-orange).
- (✓) R508: 3300 Ω (orange-orange-red).
- (✓) R509: 10 kΩ (brown-black-orange).
- (✓) Solder the leads to the foil and cut off the excess lead lengths.

PICTORIAL 2-2

START ↘

NOTE: When you install each of the following components, line up the flat or tab on the component with the outline of the flat or tab on the circuit board. Then insert the leads in the corresponding holes in the circuit board. Position it 3/16" above the circuit board; then solder the leads to the foil and cut off the excess lead lengths.

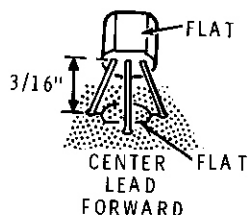

() IC501: 78L05 integrated circuit (#442-627).

() Q502: MPS6520 transistor (#417-134).

() Q501: MPSA20 transistor (#417-801).

() Q503: MPSA20 transistor (417-801).

() VD502: MV2107 diode (#56-642). This diode has only two leads.

() Q504: MPSA55 transistor (#417-865).

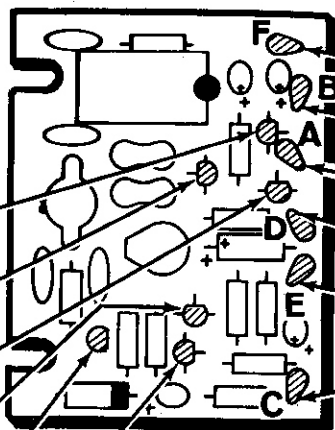

CONTINUE ↘

() Prepare six 1-1/4" gray stranded wires.

Connect one end of the prepared wires to the circuit board holes as follows. Solder each wire to the foil and cut off the excess lead length as you install it. The other end of each wire will be connected later.

() 1-1/4" wire at F.

() 1-1/4" wire at B.

() 1-1/4" wire at A.

() 1-1/4" wire at D.

() 1-1/4" wire at E.

() 1-1/4" wire at C.

PICTORIAL 2-3



START →

NOTE: When you install ceramic capacitors, do not push the insulated portion of the leads into the circuit board holes. This could make it difficult to solder the leads to the foil.

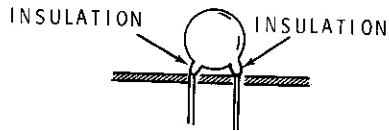

C506: .1 μ F ceramic.

C503: .1 μ F ceramic.

C513: 240 pF mica.

C509: 42 pF mica.

C505: 4.7 pF ceramic.

C512: .01 μ F ceramic.

Solder the leads to the foil and cut off the excess lead lengths.

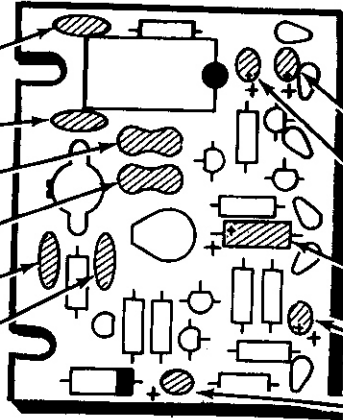

CONTINUE →

NOTE: When you install electrolytic and tantalum capacitors, be sure to match the positive (+) mark or color dot on the capacitor with the positive (+) mark on the circuit board as shown.

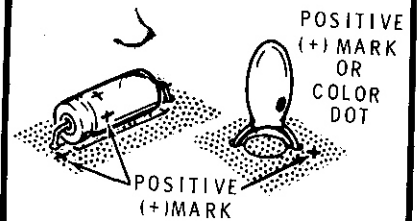

C501: .68 μ F tantalum.

C502: .68 μ F tantalum.

C507: .22 μ F tantalum.

C508: .68 μ F tantalum.

C504: .68 μ F tantalum.

Solder the leads to the foil and cut off the excess lead lengths.

PICTORIAL 2-4

START ↘

✓ C511: 2.7-20 pF trimmer (#31-57). Solder two lugs to the foil. Do not solder the lug that has no foil.

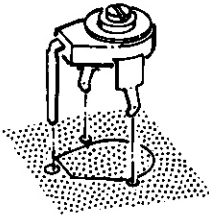

✓ L501: .165 μH coil (#40-1907). Install the coil so the tab is positioned as shown on the circuit board. Hold this coil down **tightly** against the circuit board while you solder the leads to the foil. Then cut off the excess lead lengths.

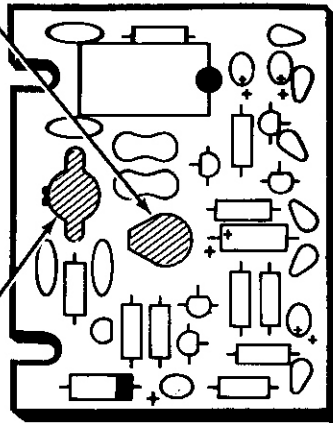
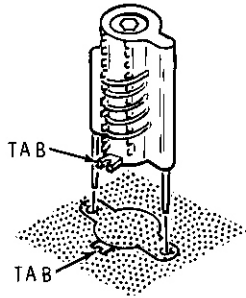

CONTINUE ↘

CIRCUIT BOARD CHECKOUT

Carefully inspect the foil side of the circuit board for the following most commonly made errors.

- () Unsoldered connections.
- () "Poor" solder connections.
- () Solder bridges between foil patterns.
- () Protruding leads which could touch together or the chassis when the circuit board is installed later.

Refer to the illustrations where the parts were installed as you make the following visual checks.

- () Transistors for proper **type** and **installation**.
- () Integrated circuits for the proper **type** and **installation**.
- () Electrolytic capacitors for the correct position of the positive (+) mark.
- () Diodes for the correct orientation.

PICTORIAL 2-5

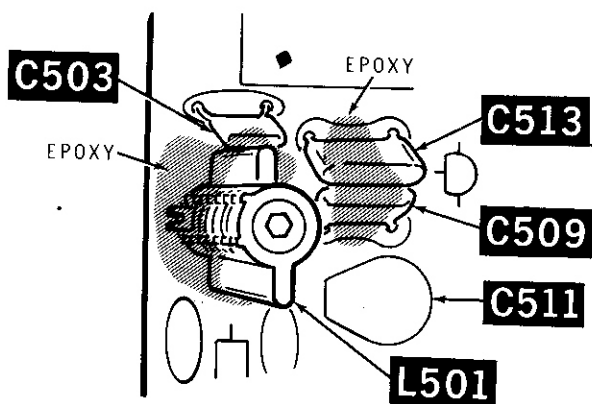

PICTORIAL 2-6

Refer to Pictorial 2-6 for the following steps.

- (✓) Push the tops of capacitors C513 and C509 together. Also push the top of capacitor C503 against coil L501.

NOTE: Perform the next three steps carefully but quickly. The epoxy sets in five minutes.

- (✓) Open the package of epoxy. Then follow the directions packed with the epoxy to thoroughly mix it together.

NOTE: Be careful in the next two steps that you do not get epoxy on trimmer capacitor C511.

- (✓) Use a toothpick or similar object to put some epoxy around the bottom of coil L501. Use only enough epoxy to secure the coil to the circuit board.
- (✓) Also put some epoxy between capacitor C503 and coil L501 and capacitor C513 and C509 to hold them together. Use only enough epoxy to hold the capacitors together.
- (✓) Discard the remaining epoxy.

INSTALLATION

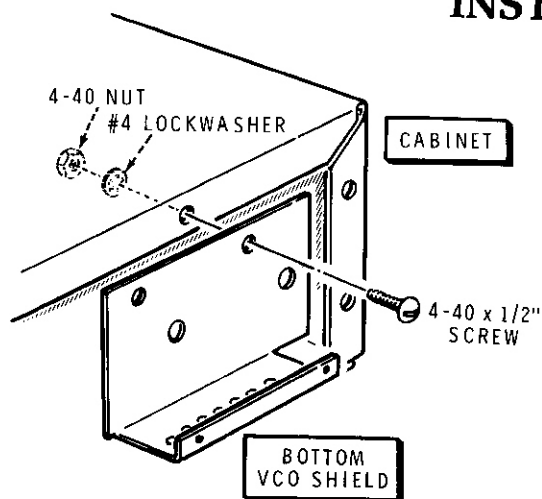

Detail 2-7A

Refer to Pictorial 2-7 (Illustration Booklet, Page 6) for the following steps.

NOTES:

1. You will use the Transceiver cabinet to hold the bottom VCO shield in a convenient position while you prepare the shield.
2. Perform the following steps carefully. They have a direct affect on the proper operation of the Transceiver.

- (✓) Locate the Transceiver cabinet.
- (✓) Refer to Detail 2-7A and temporarily mount the bottom VCO shield (#206-1243) to the cabinet with 4-40 x 1/2" hardware. Be sure to position the shield as shown.

NOTE: When you solder the eyelet to the shield in the next step, do not allow the solder to flow into the eyelet.

- (✓) Refer to Detail 2-7B, Part A, and prepare two eyelets as shown. Then refer to Part B and insert one of the eyelets into hole EA in the shield and solder the flange on the eyelet to the shield.
- (✓) In the same way, mount the other eyelet at EB.
- (✓) Loosen the hardware that holds the shield to the cabinet. Then rotate the shield so the eyelets extend upward.
- (✓) Refer to Detail 2-7C, Part A, and prepare five .001 μ F feedthrough capacitors as shown. NOTE: Two extra feedthrough capacitors are supplied in case you break one.
- (✓) Refer to Detail 2-7C, Part B, and insert a prepared .001 μ F feedthrough capacitor into hole C515 in the shield. Then solder the flange on the capacitor to the shield.

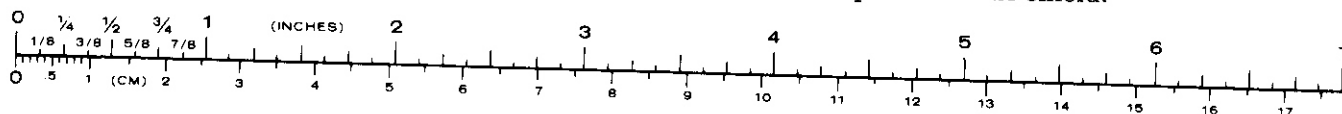

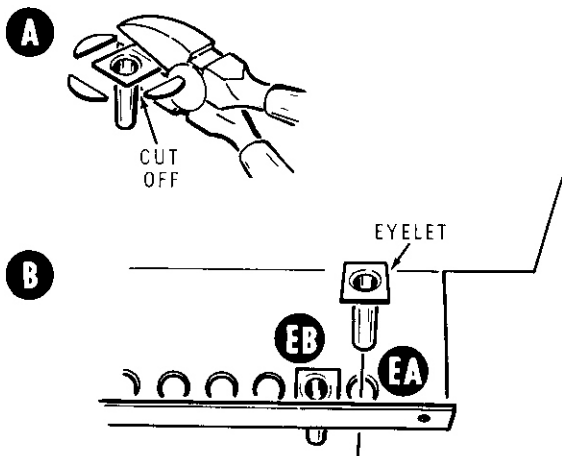

Detail 2-7B

- (✓) In the same way, install prepared feedthrough capacitors at C514, C517, C518, and C516. Allow the shield to cool before you proceed to the next step.
- (✓) Remove the VCO shield from the cabinet. Set the cabinet and hardware aside until they are called for in a step.
- (✓) Mount a small solder lug to the shield at EC as shown in the Pictorial. Use 4-40 × 1/2" hardware and a #4 flat washer.
- (✓) In the same way, mount another small solder lug at ED.

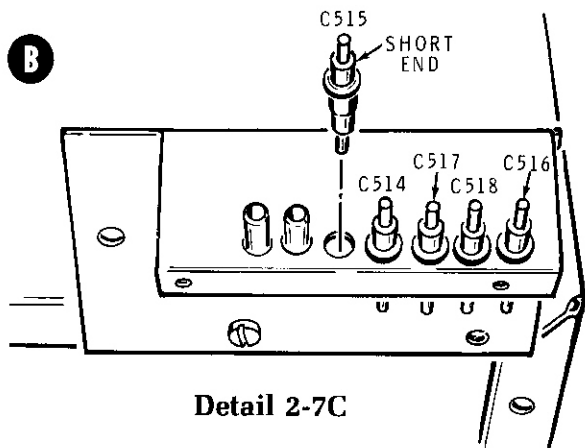
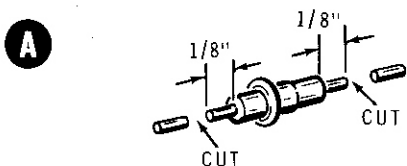

Detail 2-7C

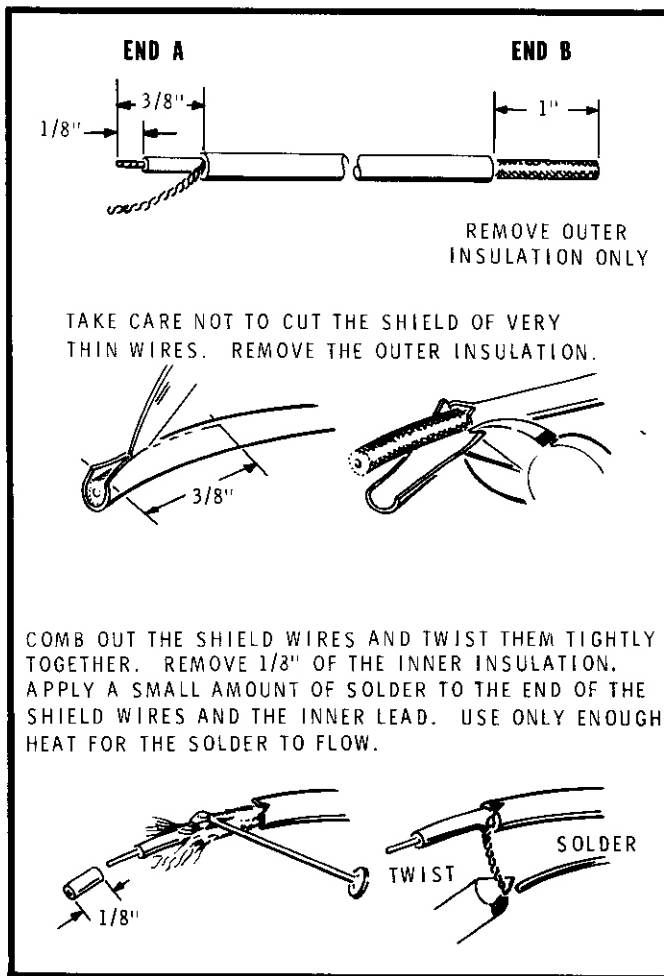

Detail 2-7D

- (✓) Refer to Detail 2-7D and prepare a 5-1/2" length of shielded cable as shown.
- (✓) Refer to Detail 2-7E and prepare end B of the cable as shown. Be careful you do not cut the insulation on the inner wire of the cable.

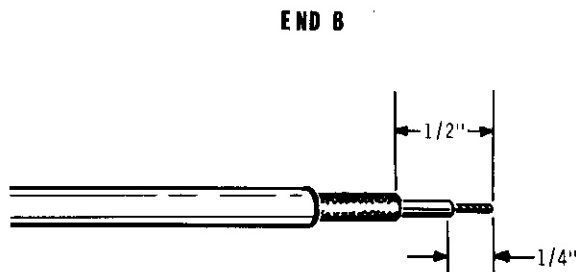

Detail 2-7E

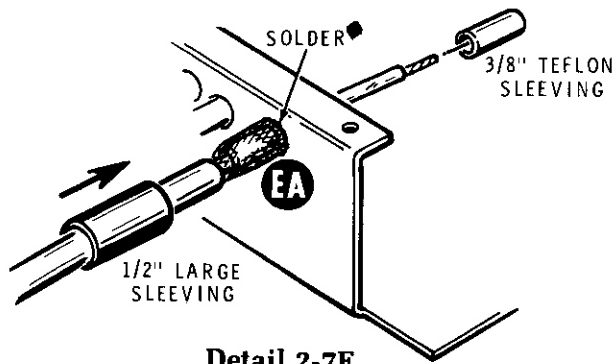

Detail 2-7F

(✓) Refer to Detail 2-7F and install end B of the cable into the eyelet at EA as follows:

1. Push the inner wire at end B of the cable into the eyelet at EA. At the same time, form the shield braid over the eyelet as shown.
2. Cut a 3/8" length of teflon sleeving.
3. From inside the VCO shield, slide the 3/8" length of sleeving over the inner cable wire and into the eyelet.
4. Carefully solder the shield braid to the eyelet. Do not move the assembly until the solder cools.
5. Cut a 1/2" length of large (heat shrinkable) sleeving.
6. Install the sleeving over the shield braid on the eyelet. Then use heat to shrink the sleeving as you did before.

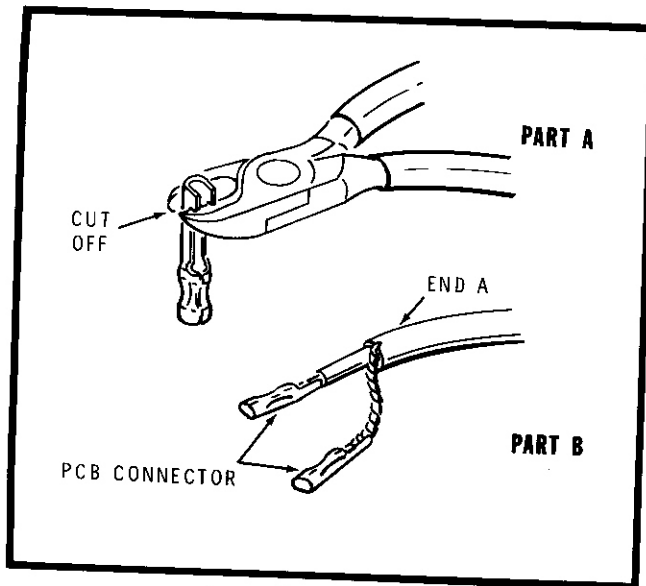

Detail 2-7G

(✓) Refer to Detail 2-7G and prepare two PCB connectors as shown. Then install the connectors on the inner and shield lead at end A of the cable.

(✓) Cut two 1/2" lengths of medium (heat shrinkable) sleeving.

(✓) Install a 1/2" length of sleeving on each PCB connector on the end of the cable. This end of the cable will be connected later.

(✓) Refer to Detail 2-7H and prepare an 8" shielded cable as shown.

(✓) Refer back to Detail 2-7E and prepare end B of the cable as shown.

(✓) Install end B of the cable in the eyelet at EB. Use the same procedure as you did for the other cable. Refer back to to Detail 2-7F if necessary.

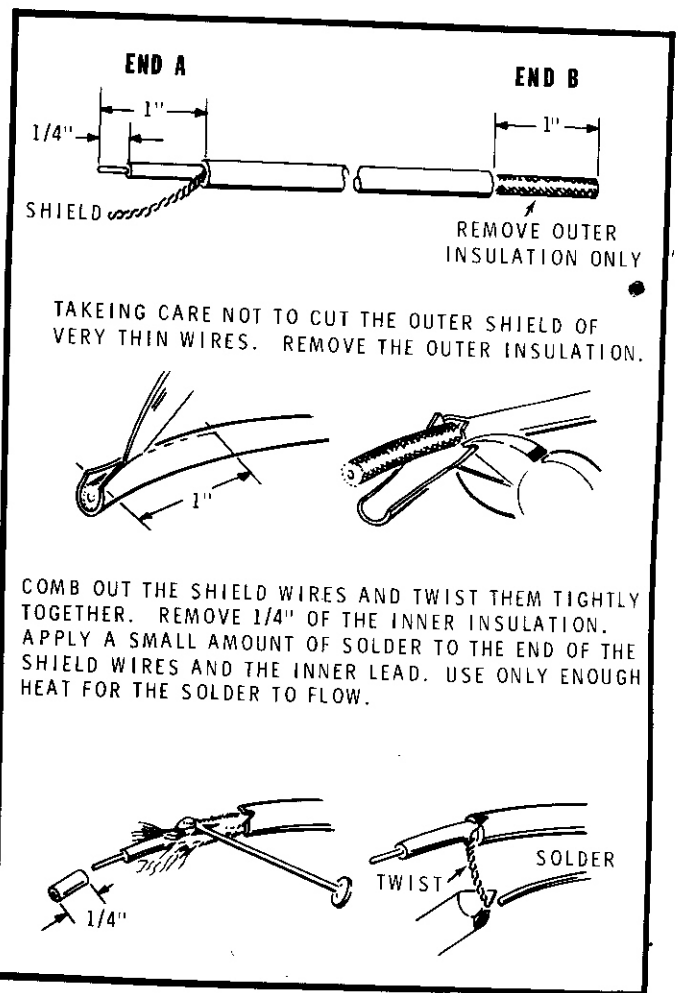

Detail 2-7H

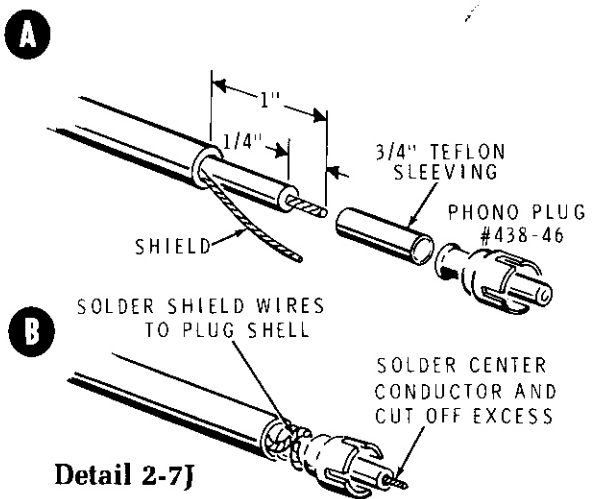

Detail 2-7J

(✓) Refer to Detail 2-7J and install a phono plug (#438-46) on end A of this cable as shown. Be sure to slide a 3/4" length of teflon sleeving onto the inner lead before you install the plug.

Refer to Pictorial 2-8 for the following steps.

NOTE: When you install the nylon screw in the next step, be careful you do not overtighten this screw.

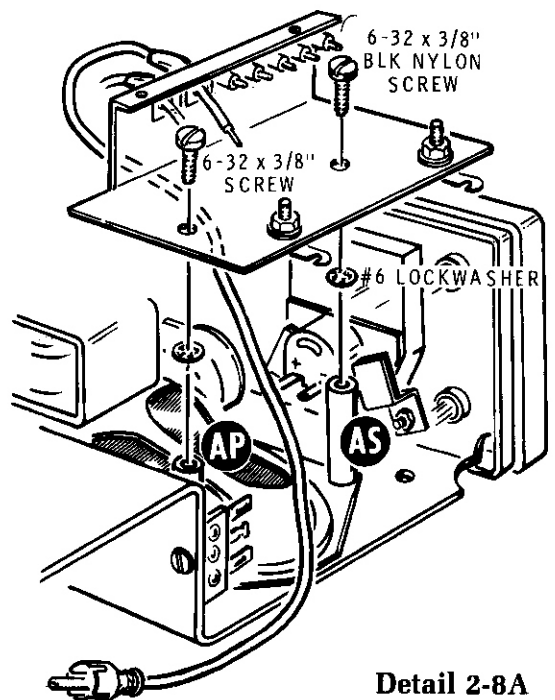

Detail 2-8A

(✓) Refer to Detail 2-8A and mount the bottom VCO shield onto the spacers on the chassis. Use a 6-32 x 3/8" black nylon screw and #6 lockwasher at AS. Use a 6-32 x 3/8" screw and #6 lockwasher at AP. Be sure to route the shielded cable with the phono plug on the other end under the shield as shown. Also, be sure to position the harness between the shield and the speaker, as shown in the Pictorial.

- () Locate the VCO circuit board. Then position it near the shield as shown.
- () Bend a small hook in the ends of the two shielded cables coming from the eyelets at EA and EB. Then connect the free end of the wire coming from circuit board hole F to the ends of these cables as shown (S-3).

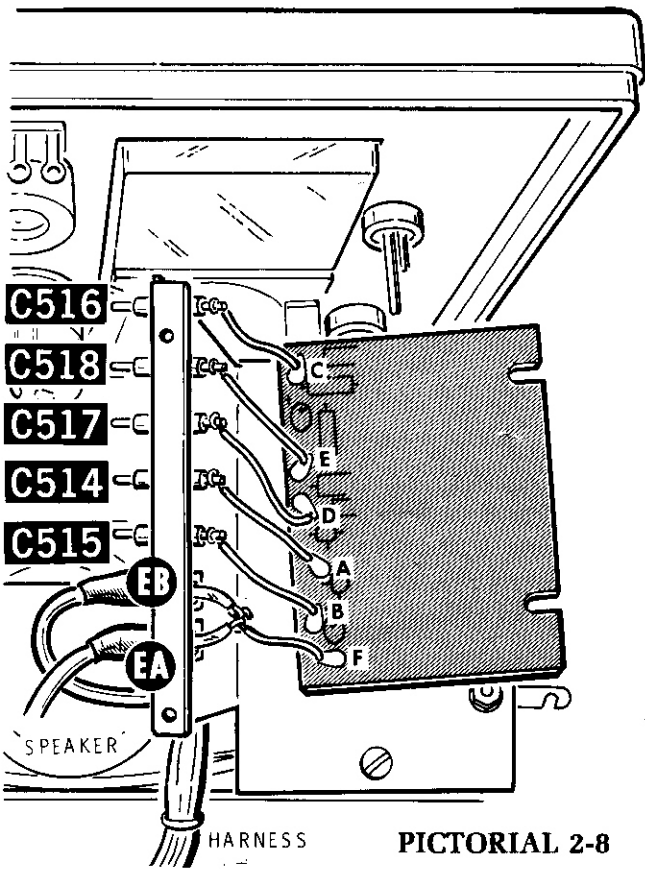

PICTORIAL 2-8

Connect the free ends of the wires coming from the circuit board holes to the feedthrough capacitors as follows:

- (✓) Wire from hole B to C515 (S-1).
- (✓) Wire from hole A to C514 (S-1).
- (✓) Wire from hole D to C517 (S-1).
- (✓) Wire from hole E to C518 (S-1).
- (✓) Wire from hole C to C516 (S-1).



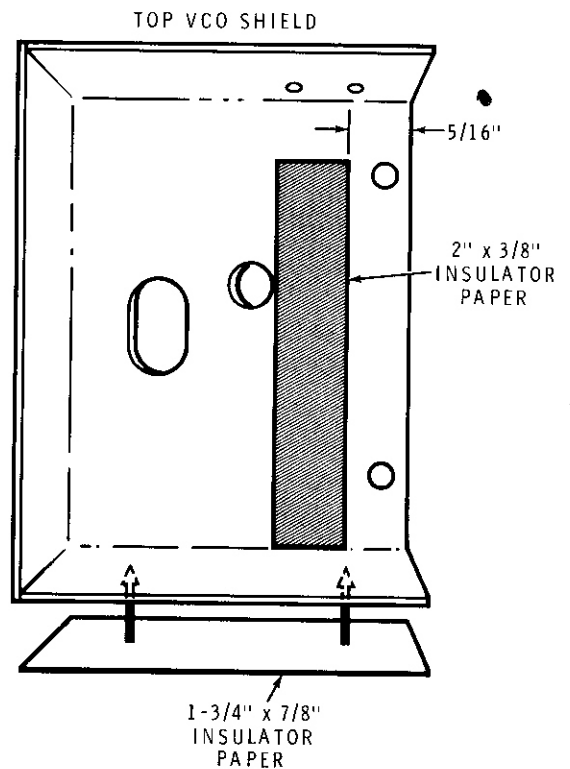
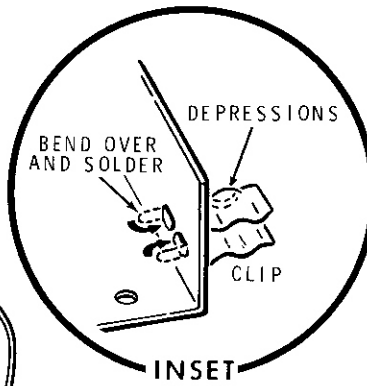
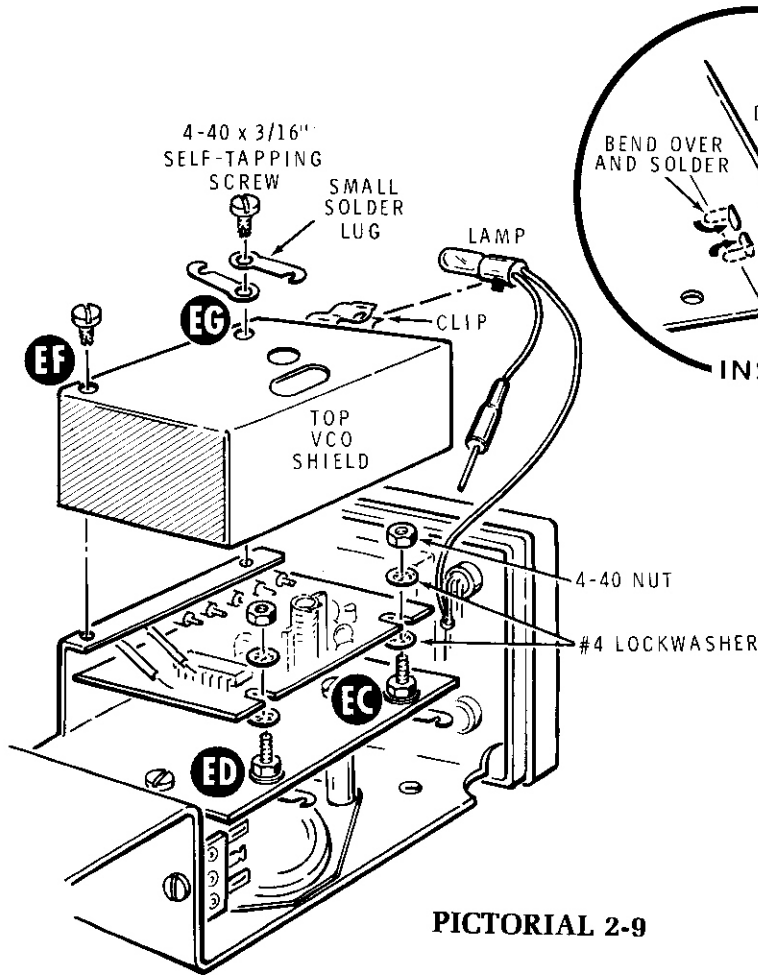

PICTORIAL 2-9

Detail 2-9B

Refer to Pictorial 2-9 for the following steps.

- (✓) Carefully push the VCO circuit board into the shield. Then mount the board with two #4 lockwashers and a 4-40 nut at EC and ED. Be sure you do not pinch any wires between the circuit board and the shield.

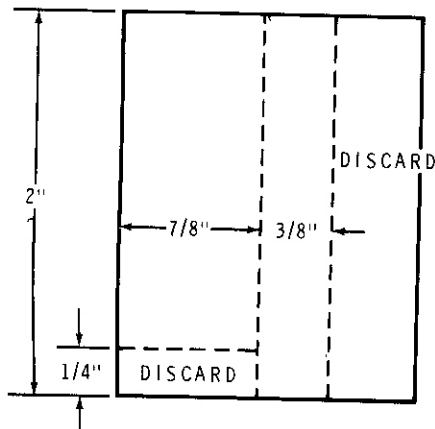

Detail 2-9A

- (✓) Install a clip onto the top VCO shield as shown in the inset drawing on the Pictorial. Be sure to position the clip with the depressions as shown. Bend the tabs over on the inside of the shield and solder them to the shield.
- (✓) Cut two insulators from the 2" x 1-3/4" piece of insulator paper as shown in Detail 2-9A.
- (✓) Carefully peel the backing paper from the 2" x 3/8" piece of insulator paper. Then press the insulator onto the inside of the top VCO shield as shown in Detail 2-9B.

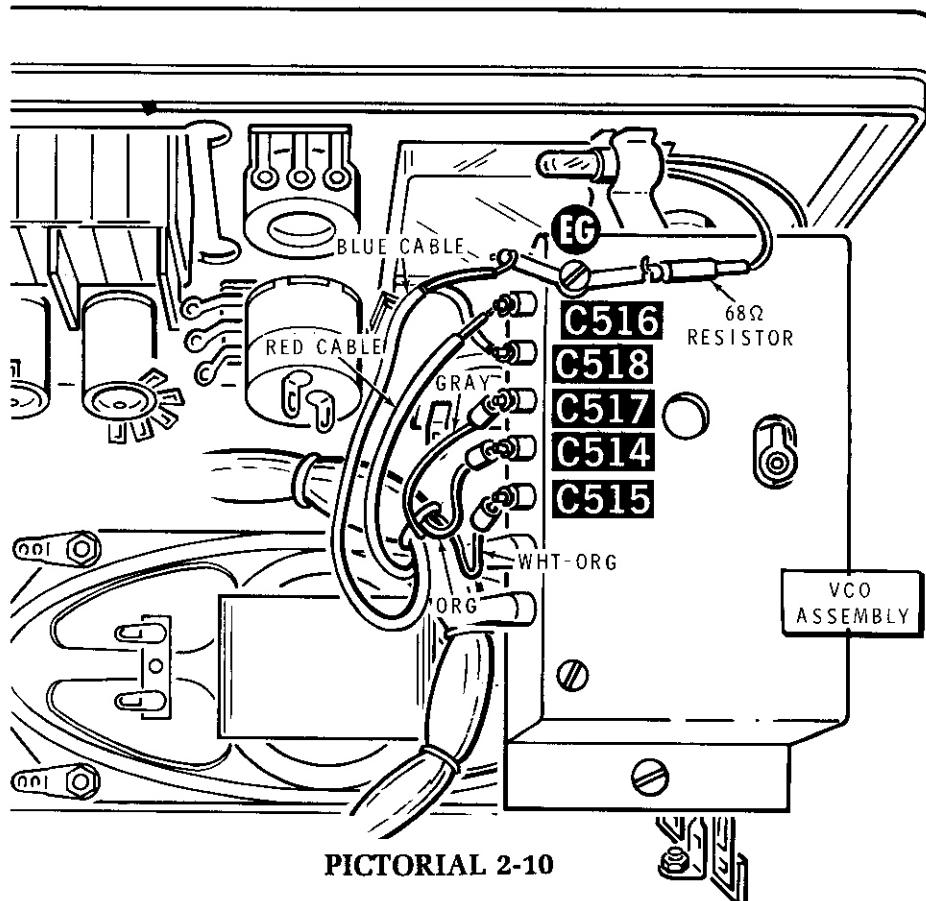

PICTORIAL 2-10

- (✓) Carefully peel the backing paper from the 1-3/4" × 7/8" piece of insulator paper. Then press the insulator onto the side of the top VCO shield as shown in Detail 2-9B.
 - (✓) Push the lamp coming from the chassis into the clip as shown.
 - (✓) Mount the top VCO shield to the bottom VCO shield at EF with a 4-40 × 3/16" self-tapping screw.
 - (✓) Mount two small solder lugs at EG with a 4-40 × 3/16" self-tapping screw. Be sure to position the solder lugs as shown.
 - (✓) Slide a 1.07 μH ferrite bead onto the end of the white-orange wire. Then connect the wire to capacitor C515 (S-1).
 - (✓) Slide a 1.07 μH ferrite bead onto the end of the orange wire. Then connect the wire to C514 (S-1).
 - (✓) Slide another 1.07 μH ferrite bead onto the end of the gray wire. Then connect the wire to C517 (S-1).
 - (✓) Connect the blue cable inner lead to C518 (S-1) and the shield lead to the solder lug at EG (S-1). Use 1/2" of small sleeving on the shield lead.
 - (✓) Cut the shield lead off of the red cable. Then connect the inner wire to C516 (S-1).
 - (✓) Connect the free end of the 68 ohm resistor, coming from the lamp assembly, to the indicated solder lug at EG (S-1).
- Refer to Pictorial 2-10 for the following steps.
- Connect the wires coming from BO 8 of the wire harness to the feedthrough capacitors on the VCO assembly as follows:
- (✓) Remove another 1/4" of insulation (total 1/2") from the free ends of the orange, gray, and white-orange harness wires.

Set the chassis assembly aside until it is called for.

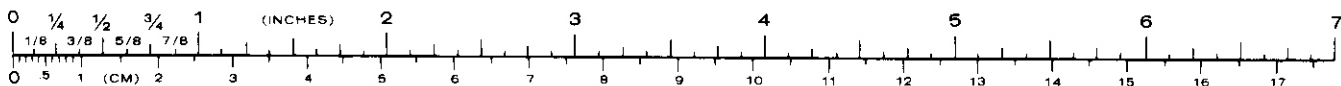

RECEIVER CIRCUIT BOARD

PARTS LIST

- () Refer to the Pack Index Sheet and locate Pack #2.
- () Unpack these parts and check each part against the following list. The key numbers correspond to the numbers on the "Receiver Circuit Board Parts Pictorial" (Illustration Booklet, Page 7).

To order a replacement part, always include the PART NUMBER. Use the Parts Order Form furnished with this kit. If one is not available, see "Replacement Parts" inside the rear cover of this Manual. For price information, refer to the separate "Heath Parts Price List."

KEY No.	HEATH Part No.	QTY.	DESCRIPTION	CIRCUIT Comp. No.
---------	----------------	------	-------------	-------------------

RESISTORS, 1/4-Watt

NOTES:

- Resistors may be packed in more than one envelope. Open all of the resistor envelopes in this pack before you check them against the following list.
- The following resistors have a tolerance of 10% unless otherwise noted. 10% is indicated by a fourth color band of silver; 5% is indicated by a gold fourth band.

A1	1-55-12	1	10 Ω, 5% (brown-black-black)	R208
A1	1-1-12	9	100 Ω (brown-black-brown)	R207, R211, R212, R216, R218, R221, R230, R231, R247
A1	1-43-12	1	120 Ω (brown-red-brown)	R232
A1	1-17-12	1	220 Ω (red-red-brown)	R235
A1	1-21-12	3	270 Ω (red-violet-brown)	R203, R205, R215
A1	1-92-12	3	330 Ω, 5% (orange-orange-brown)	R219, R243, R254

KEY No.	HEATH Part No.	QTY.	DESCRIPTION	CIRCUIT Comp. No.
---------	----------------	------	-------------	-------------------

Resistors (cont'd.)

A1	1-35-12	1	470 Ω (yellow-violet-brown)	R226
A1	1-2-12	2	1000 Ω (brown-black-red)	R227, R234
A1	1-4-12	4	2200 Ω (red-red-red)	R224, R238, R242, R253
A1	1-6-12	5	3300 Ω (orange-orange-red)	R206, R209, R241, R245, R251
A1	1-7-12	1	3900 Ω (orange-white-red)	R228
A1	1-8-12	2	4700 Ω (yellow-violet-red)	R225, R245
A1	1-27-12	2	6800 Ω (blue-gray-red)	R217
A1	1-9-12	5	10 kΩ (brown-black-orange)	R204, R214, R237, R249, R252
A1	1-10-12	2	15 kΩ (brown-green-orange)	R236, R248
A1	1-45-12	4	22 kΩ (red-red-orange)	R223, R233, R239, R244
A1	1-46-12	1	27 kΩ (red-violet-orange)	R222
A1	1-41-12	1	33 kΩ (orange-orange-orange)	R202
A1	1-32-12	3	100 kΩ (brown-black-yellow)	R201, R213, R229

A1 1-11-12 1 47 kΩ *yellow black orange* R217

KEY No.	HEATH Part No.	QTY.	DESCRIPTION	CIRCUIT Comp. No.
CAPACITORS				
Mica				
B1	20-161	1	68 pF	C262
B1	20-183	1	120 pF	C237
B1	20-103	1	150 pF	C236
Ceramic				
B2	21-33	2	3.3 pF	C256, C257
B2	21-78	3	5 pF	C203, C207, C264
B2	21-169	4	6 pF	C214, C215, C216, C226
B2	21-3	2	10 pF	C201, C209
B2	21-111	1	15 pF	C213
B2	21-7	1	33 pF	C233
B2	21-11	3	150 pF	C225, C228, C263
B2	21-56	1	470 pF	C235
B2	21-140	8	.001 μ F	C204, C205, C206, C249, C254, C255, C266, C269
B2	21-176	13	.01 μ F	C211, C212, C217, C218, C219, C222, C224, C227, C259, C261, C267, C268, C271
B2	21-143	2	.05 μ F	C244, C245
B2	21-95	11	.1 μ F	C221, C223, C229, C231, C232, C234, C238, C241, C242, C265, C272
Electrolytic				
B3	25-210	1	.22 μ F (tantalum)	C248
B4	25-221	3	2.2 μ F (tantalum)	C251, C273, C274
B4	25-223	2	47 μ F (tantalum)	C246, C247
B5	25-839	1	470 μ F	C253

KEY No.	HEATH Part No.	QTY.	DESCRIPTION	CIRCUIT Comp. No.
Capacitors (cont'd.)				
Mylar				
B6	27-70	1	.0022 μ F (2200 pF)	C252
B6	27-63	1	.022 μ F	C243
Phenolic				
B7	28-3	1	.56 pF (green-blue-gray-silver)	C208
B7	28-2	2	1 pF (brown-black-white-silver)	C202, C258
INDUCTORS				
C1	40-1613	1	.15 μ H coil	L201
C2	40-1614	2	.16 μ H coil	L202, L203
C3	40-1625	1	.16 μ H coil	L204
C4	40-1616	1	.15 μ H coil	L212
C5	40-1617	1	.16 μ H coil	L213
C5	52-118	2	455 kHz transformer	L208, L210
C5	52-154	3	10.7 MHz transformer	L205, L206, L207
C6	45-82	1	350 μ H choke	RFC201
C7	52-160	1	455 kHz transformer	L209
C8	475-10	1	1.07 μ H ferrite bead	FB201
C9	45-80	1	1 mH choke (brown-black-red-silver)	L211
DIODES				
D1	56-26	2	1N191 (brown-white-brown)	D202, D203
D1	56-56	1	1N4149	D201

KEY No.	HEATH Part No.	QTY.	DESCRIPTION	CIRCUIT Comp. No.	KEY No.	HEATH Part No.	QTY.	DESCRIPTION	CIRCUIT Comp. No.
TRANSISTORS — INTEGRATED CIRCUITS (IC's)									
NOTE: Transistors and integrated circuits may be marked for identification in any of the following four ways:									
<ol style="list-style-type: none"> 1. Part number. 2. Type number. (On integrated circuits, this refers only to the numbers; the letters may be different or missing.) 3. Part number and type number. 4. Part number and a type number other than the one listed. 									
E1	417-154	1	2N2369 transistor	Q208					
E2	417-863	3	MFE131 transistor	Q201, Q202, Q203					
E2	417-290	1	MRF502 transistor	Q207					
E3	417-169	1	MPF105 transistor	Q204					
E3	417-801	7	MPSA20 transistor	Q205, Q206, Q209, Q210, Q211, Q212, Q213					
E4	442-28	1	MC1357P IC	IC202					
E4	442-610	1	TBA820 IC	IC203					
E5	442-20	1	UA703 IC	IC201					
HARDWARE									
F1	252-3	4	6-32 nut						
F2	254-1	7	#6 lockwasher						
F3	259-1	1	#6 solder lug						
MISCELLANEOUS									
	75-108	1	Paper insulator (2" x 1-3/4")						
G1	206-1198	1	RF shield						
G2	346-60	1	Clear sleeving (1-1/2")						Y205
G3	404-537	1	10.245 MHz crystal						
	404-573	1	Set of four crystal filters consisting of:						
G4	404-574	2	Filters						Y201, Y204
G4	404-575	2	Filters						Y202, Y203
G5	432-121	17	Small PCB pin (3 extra)						
G6	434-298	2	14-pin IC socket						
G7	490-111	1	IC lifter						
PART FROM THE MAIN PACK									
	85-1880-2	1	Receiver circuit board						



STEP-BY-STEP ASSEMBLY

START

() Position the receiver circuit board as shown. Then perform the steps in the following Pictorials.

NOTE: When you are instructed to install a small PCB pin (#432-121), first push the pin down firmly against the top of the circuit board. Then turn the circuit board over and solder the pin to the foil.

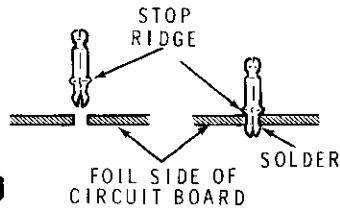

Install 7 small PCB pins (#432-121) at the following locations:

- (/) N
- (/) M
- (/) F
- () K
- (/) C
- (/) A
- (/) B

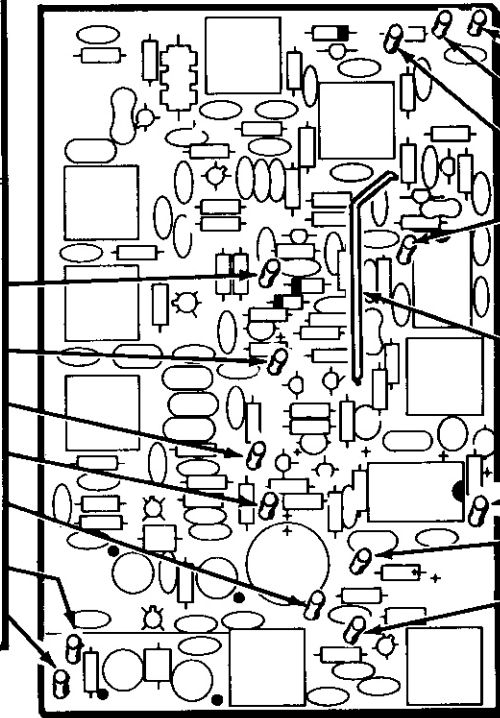

CONTINUE

Install 4 small PCB pins (#432-121) at the following locations:

- (/) E.
- (/) P.
- (/) H.
- (/) R.

(/) Prepare a 2-1/8" length of gray stranded wire.

(/) 2-1/8" gray stranded wire.

Install 3 small PCB pins (#432-121) at the following locations:

- (/) G.
- (/) L.
- (/) D.

PICTORIAL 3-1



START

- (✓) R235: 220 Ω (red-red-brown).
 - (✓) R237: 10 kΩ (brown-black-orange).
 - (✓) R214: 10 kΩ (brown-black-orange).
 - (✓) R213: 100 kΩ (brown-black-yellow).
 - (✓) R212: 100 Ω (brown-black-brown).
 - (✓) R211: 100 Ω (brown-black-brown).
 - (✓) Solder the leads to the foil and cut off the excess lead lengths.
 - (✓) R209: 3300 Ω (orange-orange-red).
 - (✓) R207: 100 Ω (brown-black-brown).
 - (✓) R206: 3300 Ω (orange-orange-red).
 - (✓) R201: 100 kΩ (brown-black-yellow).
 - (✓) R202: 33 kΩ (orange-orange-orange).
 - (✓) FB201: Ferrite bead. Use a 1" length of bare wire.
- FERRITE BEAD

BARE WIRE
- (✓) Solder the leads to the foil and cut off the excess lead lengths.

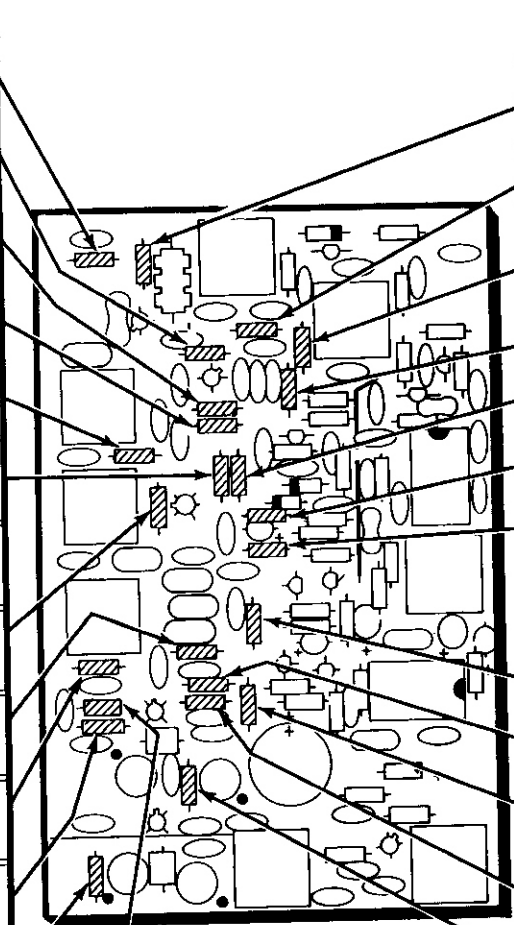

CONTINUE

- (✓) R236: 15 kΩ (brown-green-orange).
- (✓) R216: 100 Ω (brown-black-brown).
- (✓) R218: 100 Ω (brown-black-brown).
- (✓) R239: 22 kΩ (red-red-orange).
- (✓) R215: 270 Ω (red-violet-brown).
- (✓) R244: 22 kΩ (red-red-orange).
- (✓) R251: 3300 Ω (orange-orange-red).
- (✓) Solder the leads to the foil and cut off the excess lead lengths.
- (✓) R208: 10 Ω (brown-black-black).
- (✓) R205: 270 Ω (red-violet-brown).
- (✓) R230: 100 Ω (brown-black-brown).
- (✓) R204: 10 kΩ (brown-black-orange).
- (✓) R203: 270 Ω (red-violet-brown).
- (✓) Solder the leads to the foil and cut off the excess lead lengths.

PICTORIAL 3-2

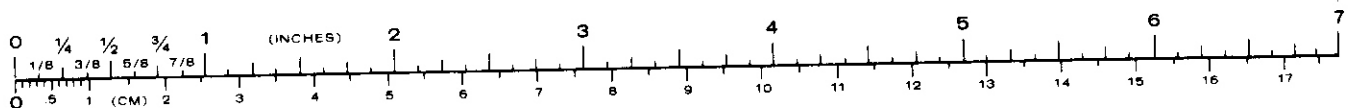

START →

NOTE: When you install a diode, position its banded end as shown in the Pictorial. A circuit will not operate properly if the diode is installed backward.

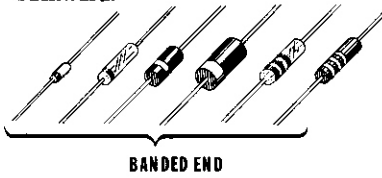

(✓) D201: 1N4149 diode (#56-56).

(✓) R217: ~~6800 Ω (blue-gray-red)~~ ^{47K} 47kΩ (blue-gray-red).

(✓) R223: 22 kΩ (red-red-orange).

(✓) R241: 3300 Ω (orange-orange-red).

(✓) R221: 100 Ω (brown-black-brown).

(✓) R242: 2200 Ω (red-red-red).

(✓) D202: 1N191 diode (#56-26).

(✓) D203: 1N191 diode (#56-26).

(✓) Solder the leads to the foil and cut off the excess lead lengths.

(✓) R245: 4700 Ω (yellow-violet-red).

(✓) R246: 3300 Ω (orange-orange-red).

(✓) R248: 15 kΩ (brown-green-orange).

(✓) R249: 10 kΩ (brown-black-orange).

(✓) R247: 100 Ω (brown-black-brown).

(✓) R253: 2200 Ω (red-red-red).

(✓) R227: 1000 Ω (brown-black-red).

(✓) Solder the leads to the foil and cut off the excess lead lengths.

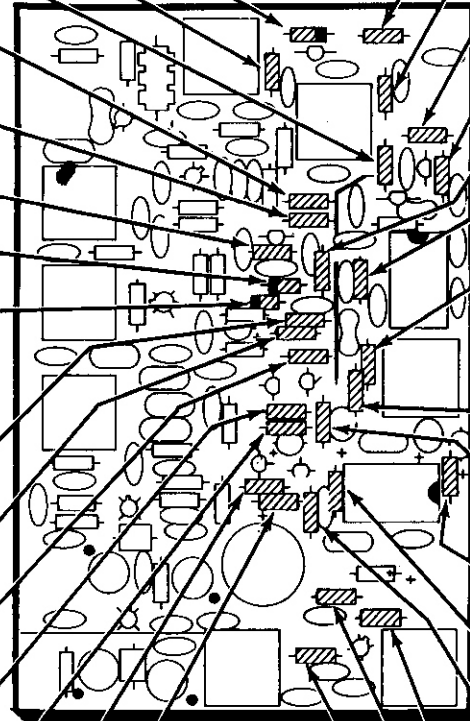

CONTINUE ↘

(✓) R238: 2200 Ω (red-red-red).

(✓) R225: 4700 Ω (yellow-violet-red).

(✓) R226: 470 Ω (yellow-violet-brown).

(✓) R224: 2200 Ω (red-red-red).

(✓) R243: 330 Ω (orange-orange-brown).

(✓) R219: 330 Ω (orange-orange-brown).

(✓) R222: 27 kΩ (red-violet-orange).

(✓) Solder the leads to the foil and cut off the excess lead lengths.

(✓) R232: 120 Ω (brown-red-brown).

(✓) R252: 10 kΩ (brown-black-orange).

(✓) R231: 100 Ω (brown-black-brown).

(✓) R229: 100 kΩ (brown-black-yellow).

(✓) R228: 3900 Ω (orange-white-red).

(✓) R234: 1000 Ω (brown-black-red).

(✓) R254: 330 Ω (orange-orange-brown).

(✓) R233: 22 kΩ (red-red-orange).

(✓) Solder the leads to the foil and cut off the excess lead lengths.

PICTORIAL 3-3

START →

NOTE: When you install each of the following transistors, line up the flat or tab on the transistor with the outline of the flat or tab on the circuit board. Then insert the leads in the corresponding holes in the circuit board. Position it 1/4" above the circuit board; then solder the leads to the foil and cut off the excess lead lengths.

(✓) Q208: 2N2369 transistor (#417-154).

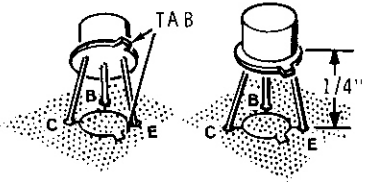

Install three MFE131 transistors (#417-863) at the following locations:

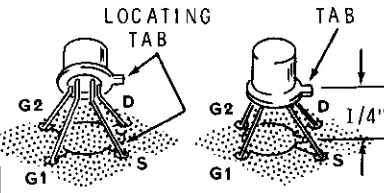

- (✓) Q203
- (✓) Q202
- (✓) Q201

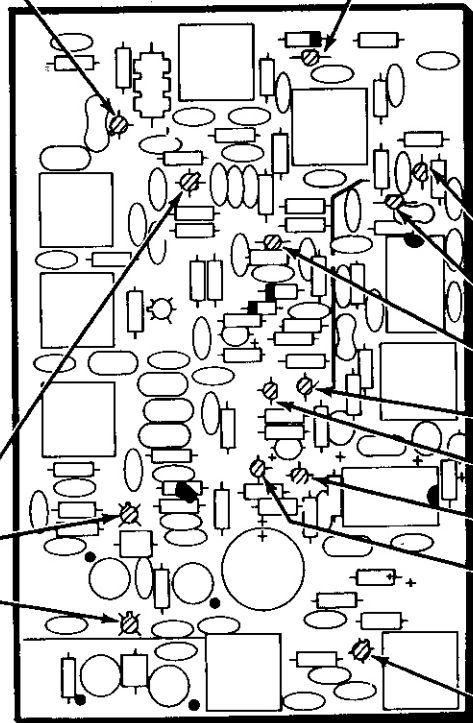

CONTINUE ↘

(✓) Q204: MPF105 transistor (#417-169).

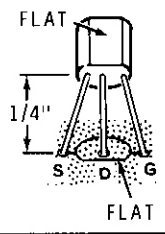

Install seven MPSA20 transistors (#417-801) at the following locations:

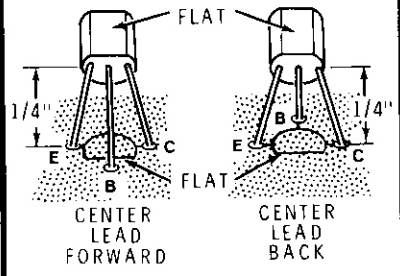

- (✓) Q205
- (✓) Q206
- (✓) Q209
- (✓) Q210
- (✓) Q211
- (✓) Q212
- (✓) Q213

(✓) Q207: MRF502 transistor (#417-290).

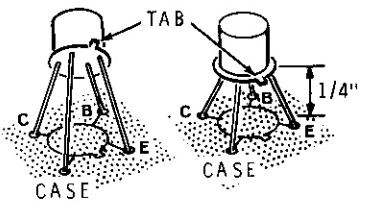

PICTORIAL 3-4

START

NOTE: When you mount the following choke, be sure you bend the leads toward the slots in the core.

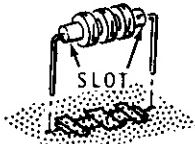

(✓) RFC201: 350 μ H choke (#45-82). Mount this choke so its body is 1/16" above the circuit board.

(✓) L211: 1 mH choke (#45-80, brown-black-red-silver).

(✓) Solder the leads to the foil and cut off the excess lead lengths.

(✓) Position the UA703 integrated circuit (#442-20) as shown and cut off the lead nearest the tab.

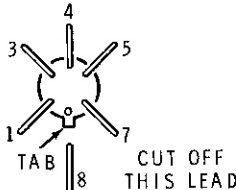

(✓) IC201: UA703 IC (#442-20). Position the tab on the IC over the outline of the tab on the circuit board. Then insert the leads in the corresponding holes in the circuit board. Position it 1/4" above the circuit board. Then solder the five leads to the foil and cut off the excess lead lengths.

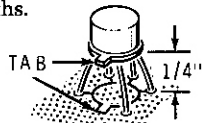

(✓) 14-pin IC socket. Solder the lugs to the foil. Push the 1 mH choke (L211) out of the way as necessary.

(✓) Refer to Detail 3-5A and use long-nose pliers to remove the indicated pin from a 14-pin IC socket. Discard the removed pin.

(✓) Refer to Detail 3-5B and install the prepared IC socket as shown. Be sure to position the space on the socket where you removed the pin as shown. Your board may or may not have a hole at this location. Solder the lugs to the foil.

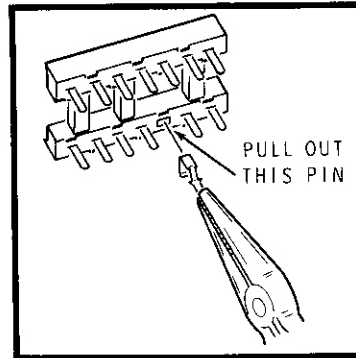

Detail 3-5A

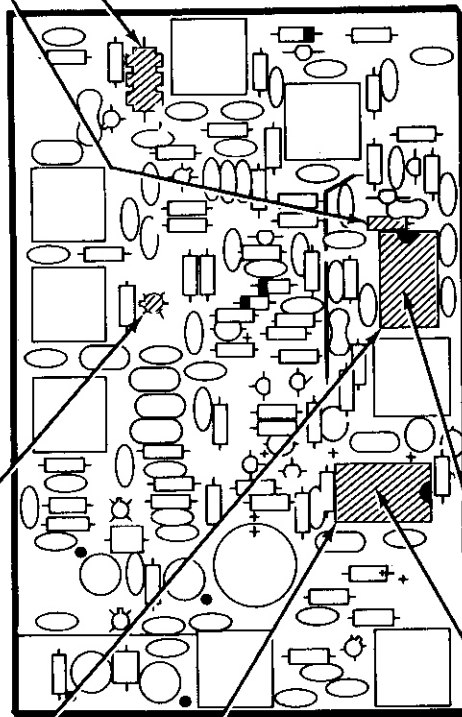

PICTORIAL 3-5

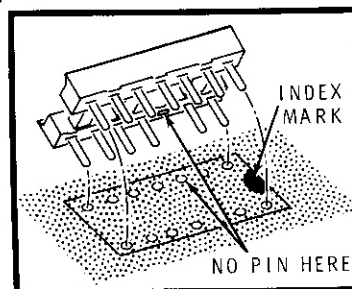

Detail 3-5B

CONTINUE

NOTE: The indexed (pin 1) end of inline integrated circuits may be marked in a number of ways such as a notch, triangle, dot, the numeral 1, etc.

SMALL INDENTATION OR DOT

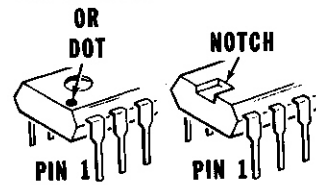

NOTCH

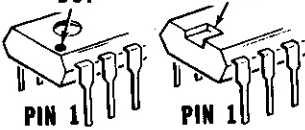

TRIANGLE

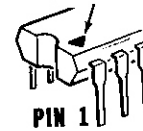

RIDGE

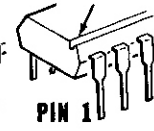

Be sure you install each IC so its pin 1 end is toward the index mark on the circuit board.

Before you apply downward pressure to an IC, make sure each pin is centered in its proper socket hole. Handle IC's with care as their pins are very easily bent.

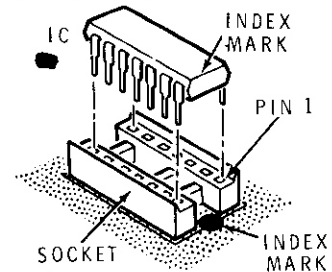

(✓) IC202: MC1357P integrated circuit (#442-28).

(✓) IC203: TBA820 integrated circuit (#442-610).

NOTE: An IC lifter has been furnished so you can remove an inline IC from its socket if this should be necessary.

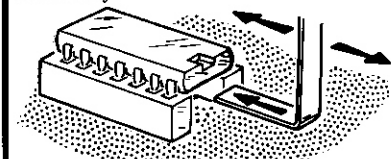

Push the shorter end of the lifter in between the IC and the socket and rock the longer portion back and forth. Be very careful, as the IC pins are very easily bent.

START 

NOTE: When you install ceramic capacitors, do not push the insulated portions of the leads into the circuit board holes. This could make it difficult to solder the leads to the foil.

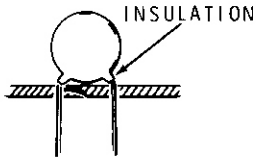

C261: .01 μ F ceramic.

C262: 68 pF mica.

C218: .01 μ F ceramic.

C221: .1 μ F ceramic.

C217: .01 μ F ceramic.

Solder the leads to the foil and cut off the excess lead length.

C211: .01 μ F ceramic.

C204: .001 μ F ceramic.

C205: .001 μ F ceramic.

C201: 10 pF ceramic.

C202: 1 pF phenolic (brown-black-white-silver).

Solder the leads to the foil and cut off the excess lead lengths.

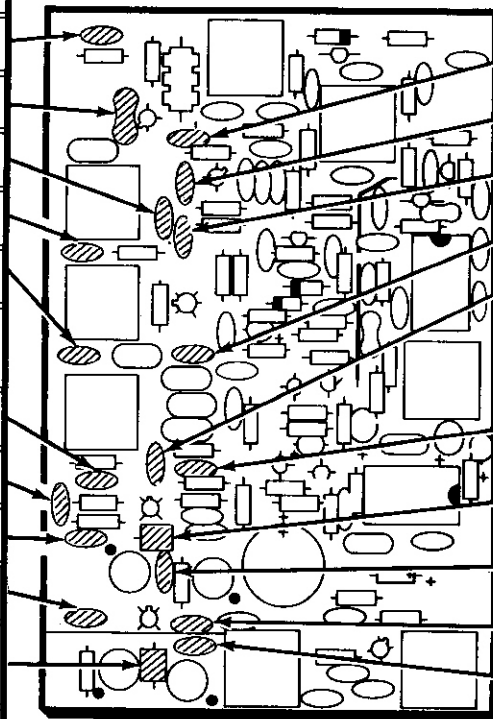
**CONTINUE** 

C263: 150 pF ceramic.

C264: 5 pF ceramic.

C222: .01 μ F ceramic.

C216: 6 pF ceramic.

C213: 15 pF ceramic.

Solder the leads to the foil and cut off the excess lead lengths.

C212: .01 μ F ceramic.

C208: .56 pF phenolic (green-blue-gray-silver).

C207: 5 pF ceramic.

C206: .001 μ F ceramic.

C203: 5 pF ceramic.

Solder the leads to the foil and cut off the excess lead lengths.

PICTORIAL 3-6

START →

- C224: .01 μ F ceramic.
- C223: .1 μ F ceramic.
- C225: 150 pF ceramic.
- C267: .01 μ F ceramic.
- C271: .01 μ F ceramic.
- Solder the leads to the foil and cut off the excess lead lengths.
- C219: .01 μ F ceramic.
- C214: 6 pF ceramic.
- C258: 1 pF phenolic (brown-black-white-silver).
- C209: 10 pF ceramic.
- C249: .001 μ F ceramic.
- Solder the leads to the foil and cut off the excess lead lengths.

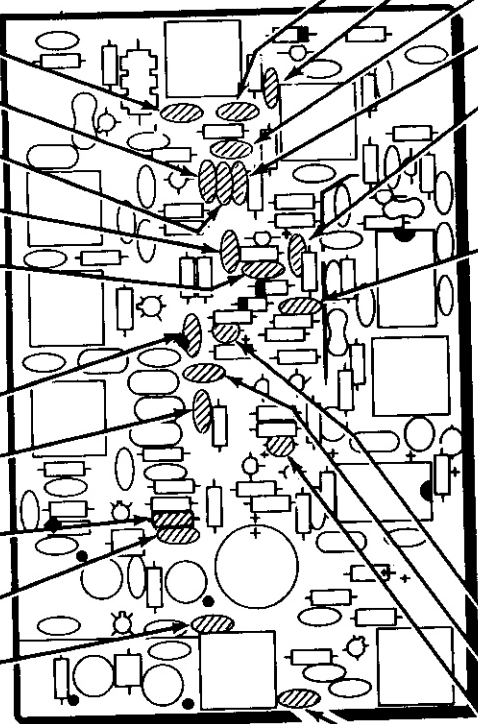

CONTINUE ↓

- C226: 33 pF ceramic. *AD?*
 - C227: .01 μ F ceramic.
 - C259: .01 μ F ceramic.
 - C228: 150 μ F ceramic.
 - C272: .1 μ F ceramic.
 - Solder the leads to the foil and cut off the excess lead lengths.
 - C269: .001 μ F ceramic.
- NOTE: When you install a tantalum capacitor, always position the positive (+) or dot marked lead of the capacitor in the positive (+) marked hole.
- POSITIVE SIGN (+)

COLOR DOT
- C273: 2.2 μ F tantalum.
 - C214: 6 pF ceramic. *AD*
 - C274: 2.2 μ F tantalum.
 - C255: .001 μ F ceramic.
 - Solder the leads to the foil and cut off the excess lead lengths.

PICTORIAL 3-7

START →

- C266: .001 μ F ceramic.
- C229: .1 μ F ceramic.
- C268: .01 μ F ceramic.
- C238: .1 μ F ceramic. Reposition the jumper wire as necessary.
- C231: .1 μ F ceramic.
- C236: 150 pF mica.
- Solder the leads to the foil and cut off the excess lead lengths.
- C246: 47 μ F tantalum. Position the positive (+) marked lead as shown on the circuit board.
- C252: .0022 μ F Mylar.
- C244: .05 μ F ceramic.
- C243: .022 μ F Mylar.
- C254: .001 μ F ceramic.
- C257: 3.3 pF ceramic.
- Solder the leads to the foil and cut off the excess lead lengths.

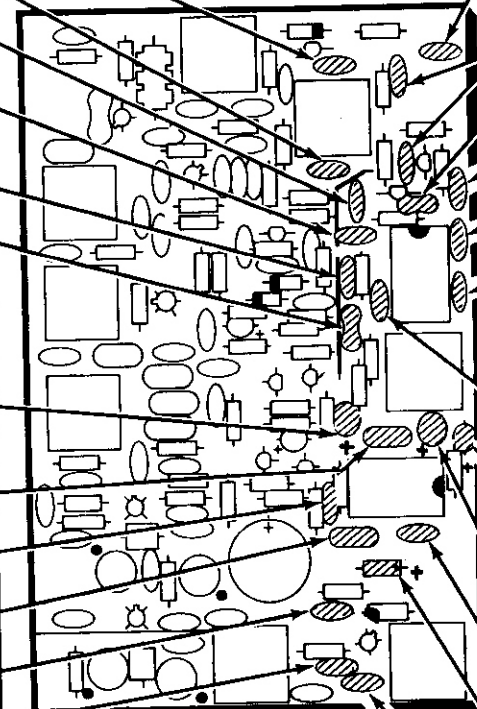
**CONTINUE** ◀

- C265: .1 μ F ceramic.
- C242: .1 μ F ceramic.
- C241: .1 μ F ceramic.
- C237: 120 pF mica.
- C235: .001 μ F ceramic. *470PF*
- C232: .1 μ F ceramic.
- C233: 33 pF ceramic.
- Solder the leads to the foil and cut off the excess lead lengths.
- C234: .1 μ F ceramic.
- C251: 2.2 μ F tantalum. Position the positive (+) lead as shown on the circuit board.
- C247: 47 μ F tantalum. Position the positive (+) lead as shown on the circuit board.
- C245: .05 μ F ceramic.
- C248: .22 μ F tantalum. Position the positive (+) lead as shown on the circuit board.
- C256: 3.3 pF ceramic.
- Solder the leads to the foil and cut off the excess lead lengths.

PICTORIAL 3-8

START

NOTES:

1. When you mount a transformer or coil, line up its lugs with the holes in the circuit board; then insert the lugs through the circuit board holes.
2. Press the coil firmly against the board. Then solder the lugs to the foil and cut off the excess lug lengths.

(✓) L208: 455 kHz transformer (#52-118).

(✓) L209: 455 kHz transformer (#52-160).

Mount three 10.7 MHz transformers (#52-154) at the following locations:

(i) L207

(✓) L206

(✓) L205

(✓) L210: 455 kHz transformer (#52-118).

(✓) L212: .15 μ H coil (#40-1616).

(✓) L213: .16 μ H coil (#40-1617).

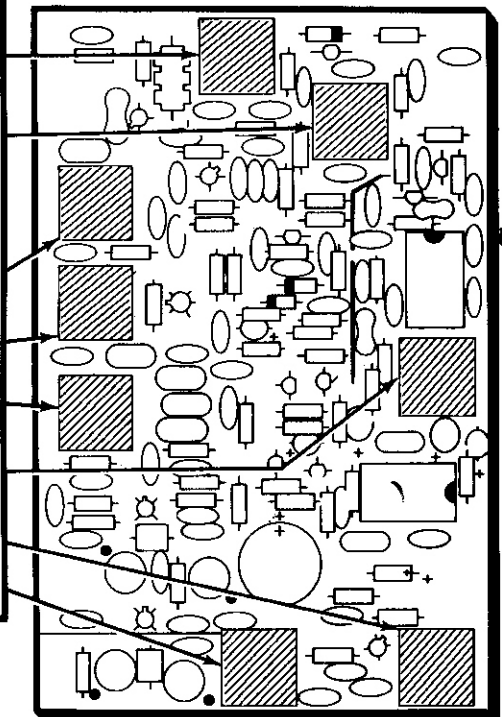

PICTORIAL 3-9

START →

NOTES:

1. In the following steps, each of the coils you will mount has a color dot on or next to one of its mounting lugs. Be sure you mount each coil so its color-coded lug is in the correspondingly marked circuit board hole.
2. If necessary, carefully bend the lugs until they will enter their circuit board holes.
3. Solder the lugs to the foil and cut off the excess lug lengths as you mount each coil.

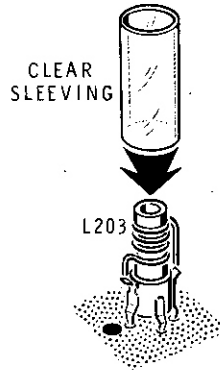

Detail 3-10A

(✓) L204: .16 μ H coil (#40-1625). Match the color-coded lug with the color dot on the circuit board.

(✓) Locate a #40-1614 coil and note that there is no wire connected to two of the mounting lugs. Cut off the upper part of both of these lugs as shown below.

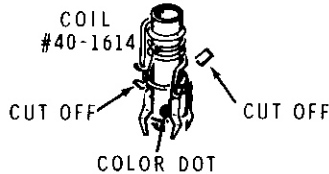

(✓) L203: Prepared #40-1614 coil.

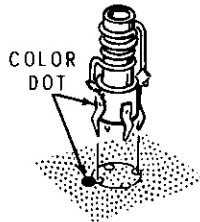

(✓) Cut the length of clear sleeving to 3/4".

(✓) Carefully work the sleeving down over coil L203 as shown in Detail 3-10A.

(✓) L201: .15 μ H coil (#40-1613). Match the color-coded lug to the color dot on the circuit board.

(✓) L202: .16 μ H coil (#40-1614). Match the color-coded lug to the color dot on the circuit board.

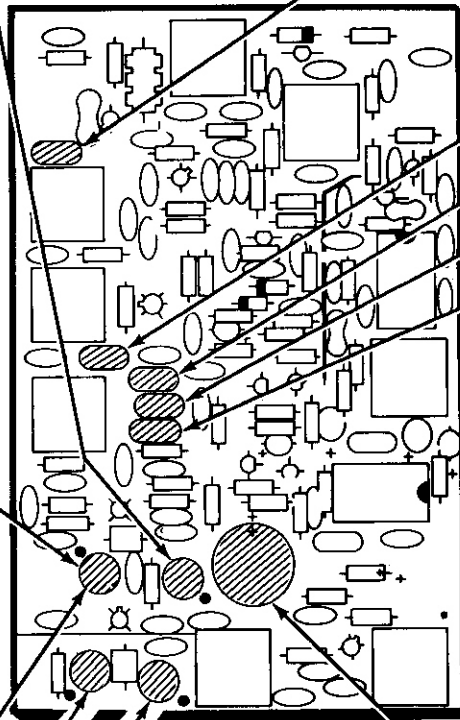

PICTORIAL 3-10

CONTINUE →

NOTE: In the following steps, solder the leads or pins to the foil and cut off the excess lengths as you install each part.

(✓) Y205: 10.245 MHz crystal (#404-537).

NOTE: The container marked #404-573 contains two #404-574 and two #404-575 filters. Use these filters when you perform the following four steps. Be sure you use the number filter called for in each step.

(✓) Y204: Filter #404-574.

(✓) Y203: Filter #404-575.

(✓) Y202: Filter #404-575.

(✓) Y201: Filter #404-574.

CAUTION: Before you install an electrolytic capacitor, note the polarity (+ or -) of the identified lead. Be sure you always connect the positive (+) lead to the positive (+) marked point on the circuit board.

IDENTIFIED LEAD IS NEGATIVE (-)

IDENTIFIED LEAD IS POSITIVE (+)

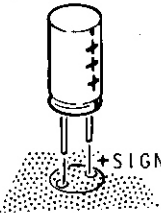
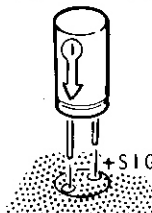

(✓) C253: 470 μ F electrolytic.

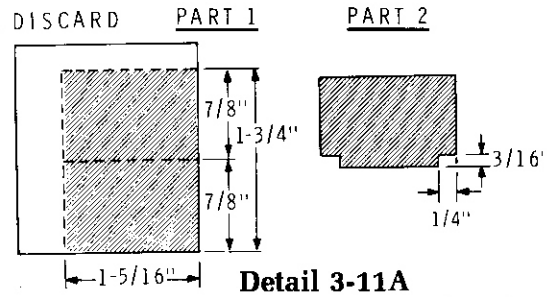

Detail 3-11A

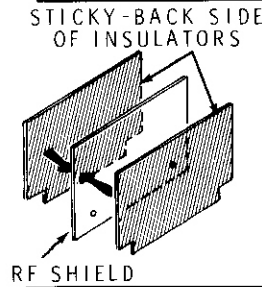

Detail 3-11B

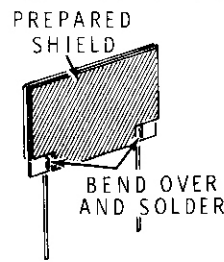

Detail 3-11C

CONTINUE

NOTE: When you mount the prepared RF shield, be sure you position it so the lead side of the shield is toward coil L203 as shown.

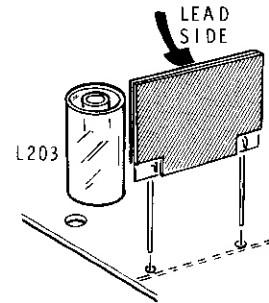

(✓) Prepared RF shield. Solder the leads to the foil and cut off the excess lead lengths.

START

(✓) Refer to Part 1 of Detail 3-11A and mark the sheet of paper insulation as shown. Then cut along the dashed lines to obtain two insulators.

(✓) Refer to Part 2 of the Detail and cut two corners from both insulators.

(✓) Refer to Detail 3-11B for the following steps:

(✓) Position the RF shield (#206-1198) as shown. Then remove the backing paper from the prepared insulators.

(✓) Press the insulators firmly onto the sides of the RF shield. NOTE: Do not cover the shield holes.

(✓) Cut two 1" bare wires.

(✓) Form both leads as shown.



(✓) Refer to Detail 3-11C and insert the short end of each lead into a shield hole. Bend the leads over as shown and solder them to the shield. Be sure both leads enter from the same side of the shield.

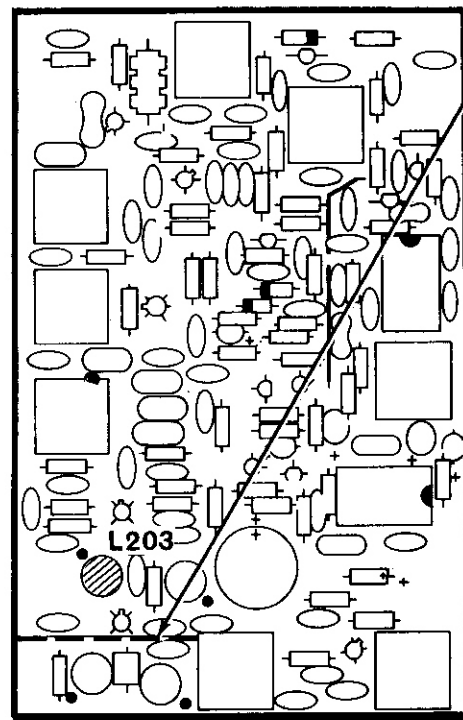

PICTORIAL 3-11

CIRCUIT BOARD CHECK-OUT

Carefully inspect the foil side of the circuit board for the following most commonly made errors.

- (✗) Unsoldered connections.
- (✗) "Cold" solder connections.
- (✗) Solder bridges between foil patterns.
- (✗) Protruding leads which could touch together.

Refer to the illustrations where the parts were installed as you make the following visual checks.

- (✓) Transistors for proper type and installation.
- (✓) Integrated circuits for the proper type and installation.
- (✓) Electrolytic capacitors for the correct position of the positive (+) mark.
- (✓) Diodes for the correct position of the banded end.

FINISH



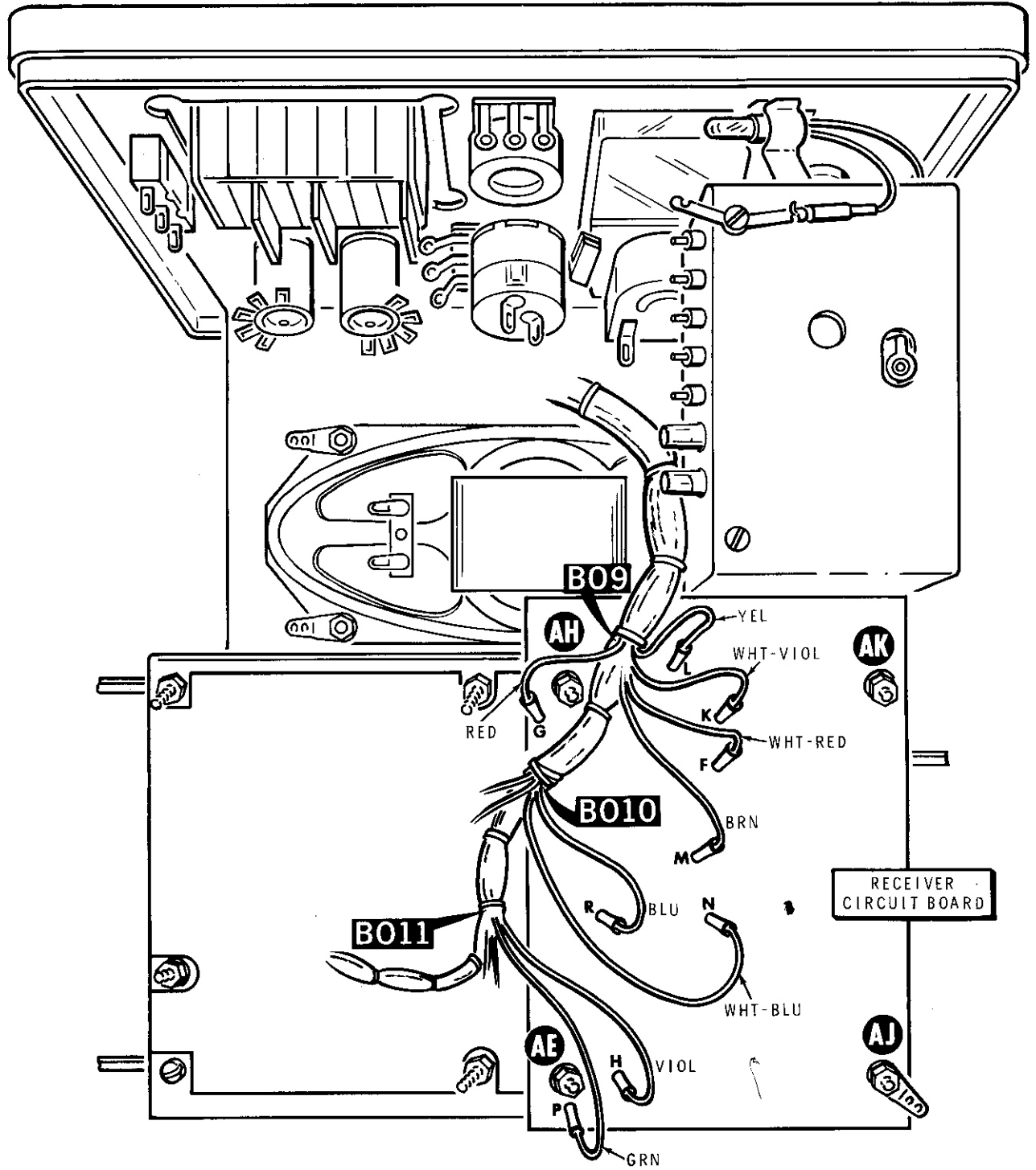

PICTORIAL 3-12

INSTALLATION

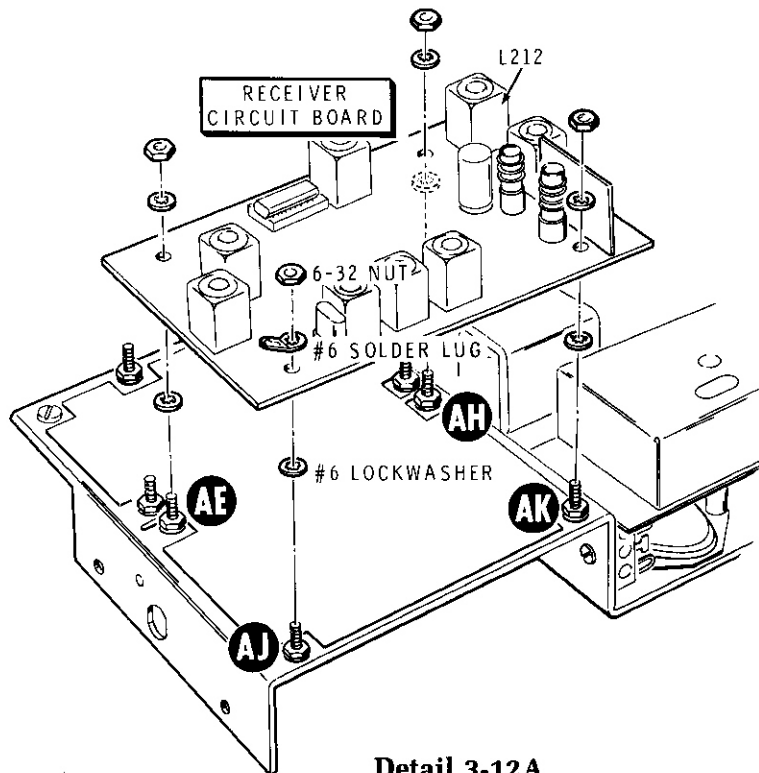

Detail 3-12A

Refer to Pictorial 3-12 for the following steps.

NOTE: If coil L212 hits the speaker in the next step, loosen the speaker mounting hardware. Then push the speaker toward the front panel to provide some clearance. Be sure to retighten the speaker hardware.

- (✓) Refer to Detail 3-12A and mount the receiver circuit board as shown. Use two #6 lockwashers and a 6-32 nut at AE, AH, and AK. Use one #6 lockwasher, a #6 solder lug, and a 6-32 nut at AJ. Be sure to position the solder lug as shown in the Pictorial.

Connect some of the wires coming from BO 9 of the wire harness to the receiver circuit board as follows:

- (✓) Red wire to pin G.
 (✓) Yellow wire to pin L.

(✓) White-violet wire to pin K.

(✓) White-red wire to pin F.

(✓) Brown wire to pin M.

Connect some of the wires coming from BO 10 of the wire harness to the receiver circuit board as follows:

(✓) Blue wire to pin R.

(✓) White-blue wire to pin N.

Connect some of the wires coming from BO 11 of the wire harness to the receiver circuit board as follows:

(✓) Green wire to pin P.

(✓) Violet wire to pin H.

Set the chassis aside until it is called for in a step.

SYNTHESIZER CIRCUIT BOARD

PARTS LIST

- () Refer to the Pack Index Sheet and locate Pack #3.
- () Unpack these parts and check each part against the following list. The key numbers correspond to the numbers on the "Synthesizer Circuit Board Parts Pictorial" (Illustration Booklet, Page 7).

To order a replacement part, always include the PART NUMBER. Use the Parts Order Form furnished with this kit. If one is not available, see "Replacement Parts" inside the rear cover of this Manual. For price information, refer to the separate "Heath Parts Price List."

KEY No.	HEATH Part No.	QTY.	DESCRIPTION	CIRCUIT Comp. No.
---------	----------------	------	-------------	-------------------

RESISTORS, 1/4-Watt

NOTES:

- Resistors may be packed in more than one envelope. Open all of the resistor envelopes in this pack before you check them against the following list.
- The following resistors have a tolerance of 10% unless otherwise noted. 10% is indicated by a fourth color band of silver; 5% is indicated by a gold fourth band.

A1	1-1-12	3	100 Ω (brown-black-brown)	R424, R425, R446
A1	1-37-12	1	150 Ω (brown-green-brown)	R454
A1	1-21-12	1	270 Ω (red-violet-brown)	R418
A1	1-24-12	1	820 Ω (gray-red-brown)	R447
A1	1-2-12	4	1000 Ω (brown-black-red)	R415, R417, R426, R457

KEY No.	HEATH Part No.	QTY.	DESCRIPTION	CIRCUIT Comp. No.
---------	----------------	------	-------------	-------------------

Resistors (cont'd.)

A1	1-4-12	23	2200 Ω (red-red-red)	R401, R402, R403, R404, R405, R406, R407, R408, R409, R411, R412, R413, R414, R429, R431, R433, R435, R437, R439, R442, R444, R445, R453
A1	1-8-12	7	4700 Ω (yellow-violet-red)	R432, R451, R452, R455, R456, R458, R459
A1	1-77-12	1	5600 Ω , 5% (green-blue-red)	R428
A1	1-80-12	4	10 k Ω , 5% (brown-black-orange)	R414, R423, R427, R448
A1	1-52-12	1	18 k Ω (brown-gray-orange)	R449
A1	1-45-12	2	22 k Ω (red-red-orange)	R416, R422
A1	1-32-12	6	100 k Ω (brown-black-yellow)	R421, R434, R436, R438, R441, R443



KEY HEATH QTY. DESCRIPTION
No. Part No.

CAPACITORS

Mica

KEY HEATH No.	Part No.	QTY.	DESCRIPTION	CIRCUIT Comp. No.
B1	20-96	2	36 pF	C408, C413
B1	20-105	1	180 pF	C404
B1	20-126	2	255 pF	C438, C439

Ceramic

KEY HEATH No.	Part No.	QTY.	DESCRIPTION	CIRCUIT Comp. No.
B2	21-33	3	3.3 pF	C407, C409, C414
B2	21-723	5	15 pF	C423, C426, C429, C433, C436
B2	21-51	1	20 pF	C442
B2	21-7	2	33 pF	C406, C441
B2	21-75	1	100 pF	C403
B2	21-140	5	.001 μ F	C418, C424, C427, C431, C434
B2	21-176	5	.01 μ F	C405, C411, C412, C437, C444
B2	21-95	4	.1 μ F	C401, C402, C415, C419

Tantalum

KEY HEATH No.	Part No.	QTY.	DESCRIPTION	CIRCUIT Comp. No.
B3	25-221	1	2.2 μ F	C416
B3	25-220	1	10 μ F	C421
B3	25-814	1	150 μ F	C443

Other

KEY HEATH No.	Part No.	QTY.	DESCRIPTION	CIRCUIT Comp. No.
B4	27-77	1	.1 μ F Mylar	C417
B5	31-71	5	3.2-18 pF trimmer	C422, C425, C428, C432, C435

KEY HEATH QTY. DESCRIPTION
No. Part No.

INDUCTORS

KEY HEATH No.	Part No.	QTY.	DESCRIPTION	CIRCUIT Comp. No.
C1	40-1616	1	.15 μ H coil	L403
C2	40-1617	1	.16 μ H coil	L402
C3	40-961	1	100 μ H coil	L401

DIODES

KEY HEATH No.	Part No.	QTY.	DESCRIPTION	CIRCUIT Comp. No.
D1	57-65	1	1N4002	D407
D1	56-56	6	1N4149	D401, D402, D403, D404, D405, D406

TRANSISTORS — INTEGRATED CIRCUITS (IC's)

NOTE: Transistors and integrated circuits may be marked for identification in any of the following four ways:

1. Part number.
2. Type number. (On integrated circuits, this refers only to the numbers; the letters may be different or missing.)
3. Part number and type number.
4. Part number with a type number other than the one listed.

KEY HEATH No.	Part No.	QTY.	DESCRIPTION	CIRCUIT Comp. No.
D2	417-240	1	40673 transistor	Q402
D2	417-290	1	MRF502 transistor	Q403
D3	417-154	1	2N2369 transistor	Q406
D4	417-864	1	MPSA05 transistor	Q414
D4	417-801	10	MPSA20 transistor	Q401, Q404, Q405, Q407, Q408, Q409, Q410, Q411, Q412, Q413
D5	443-61	3	MC4016P IC	IC401, IC402, IC403
D6	443-62	1	MC4044P IC	IC406
D6	443-1	1	SN7400N IC	IC405
D6	443-5	1	SN7473N IC	IC404

KEY No.	HEATH Part No.	QTY.	DESCRIPTION
---------	----------------	------	-------------

CRYSTALS

E1	404-584	1	21.55 MHz
E1	404-585	1	23.2333 MHz
E1	404-586	1	23.3333 MHz
E1	404-587	1	23.4333 MHz

HARDWARE

F1	252-3	4	6-32 nut
F2	254-1	8	#6 lockwasher

CIRCUIT Comp. No.

Y405
Y401
Y402
Y403

KEY No.	HEATH Part No.	QTY.	DESCRIPTION
---------	----------------	------	-------------

MISCELLANEOUS

G1	432-121	38	Small PCB pin (2 extra)
G2	432-134	3	Wire socket (1 extra)
G3	432-878	10	Crystal socket pins
G4	434-298	3	14-pin IC socket
G5	434-299	3	16-pin IC socket

PART FROM THE MAIN PACK

85-1877-2	1	Synthesizer circuit board
-----------	---	---------------------------

STEP-BY-STEP ASSEMBLY

START

() Position the synthesizer circuit board as shown. Then perform all of the steps in the following Pictorials.

NOTE: When you are instructed to install a small PCB pin (#432-121), first push the pin down firmly against the top of the circuit board. Then turn the circuit board over and solder the pin to the foil.

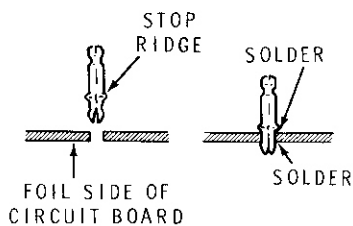

(✓) Install 12 small PCB pins (#432-121) in holes A through M.

(✓) Install 12 small PCB pins (#432-121) at the following locations:

- (✓) A8
- (✓) A4
- (✓) A2
- (✓) A1
- (✓) B8
- (✓) B4
- (✓) B2
- (✓) B1
- (✓) C8
- (✓) C4
- (✓) C2
- (✓) C1

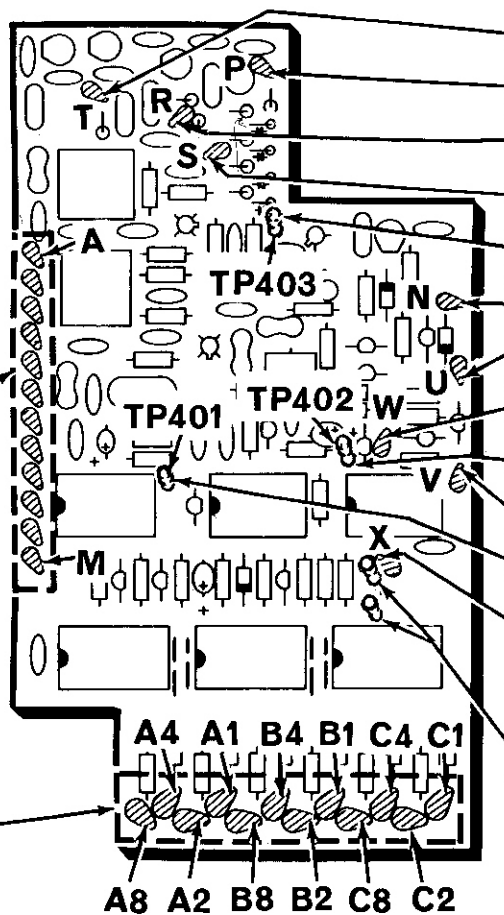

PICTORIAL 4-1

CONTINUE

Install 12 small PCB pins (#432-121) at the following locations:

- (✓) T.
- (✓) P.
- (✓) R.
- (✓) S.
- (✓) TP403.
- (✓) N.
- (✓) U.
- (✓) W.
- (✓) TP402.
- (✓) V.
- (✓) TP401.
- (✓) X.

(✓) Install two wire sockets (#432-134) at J. Insert the sockets into the circuit board and solder them to the foil.

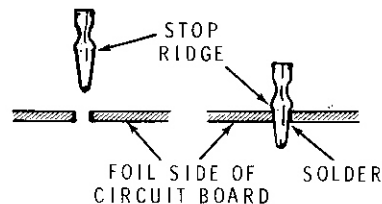

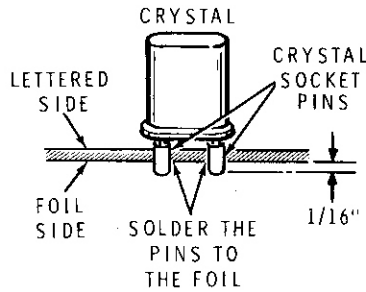

Detail 4-2A

START →

When you install the crystal socket pins in the following steps, insert the closed end of each pin through its circuit board hole until 1/16" of the pin protrudes from the foil side of the board. It may be helpful to place the pins on a crystal, as shown in Detail 4-2A, to help hold them while you solder. Be sure to remove the crystal after the connection is cool.

✓ Install two crystal socket pins (#432-878) at Y404 and solder them to the foil.

✓ Install two crystal socket pins (#432-878) at Y403 and solder them to the foil.

✓ Install two crystal socket pins (#432-878) at Y402 and solder them to the foil.

✓ Install two crystal socket pins (#432-878) at Y401 and solder them to the foil.

✓ Install two crystal socket pins (#432-878) at Y405 and solder them to the foil.

✓ Prepare four 7/8" gray stranded wires.

Install the prepared wires in the following steps.

✓ 7/8" gray wire.

✓ 7/8" gray wire.

✓ 7/8" gray wire.

✓ 7/8" gray wire.

✓ Solder the leads to the foil and cut off the excess lead lengths.

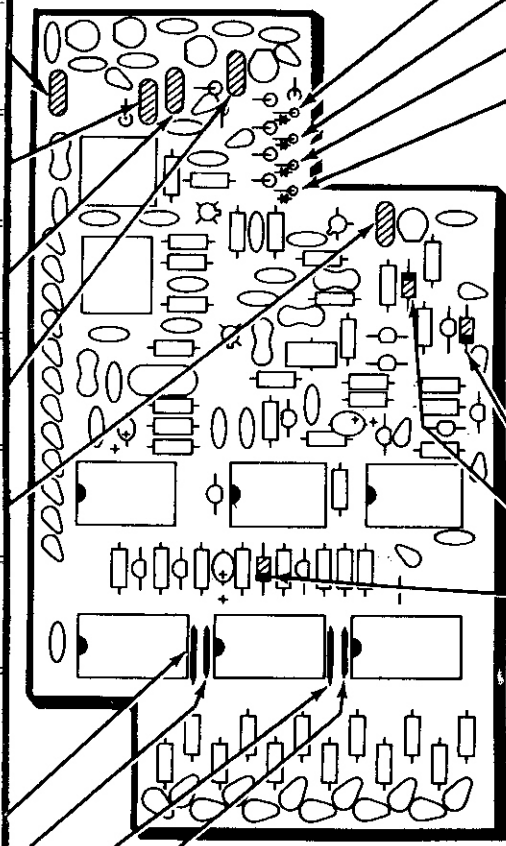

PICTORIAL 4-2

CONTINUE →

NOTE: When you perform the next step, mount each diode vertically with the banded end up as shown. Push the body down against the circuit board. Then solder the leads to the foil and cut off the excess lead lengths.

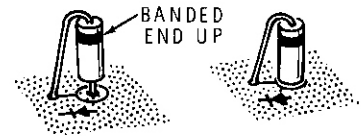

Install four 1N4149 diodes (#56-56) at the following locations:

- () D402.
- () D403.
- ✓ D404.
- ✓ D405.

NOTE: When you install a diode, as in the following steps, position its banded end as shown in the Pictorial. A circuit will not operate properly if the diode is installed backward.

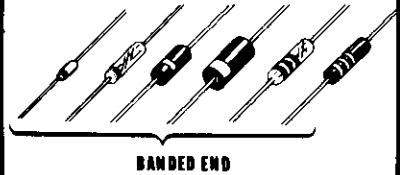

- ✓ D407: 1N4002 diode (#57-65).
- ✓ D406: 1N4149 diode (#56-56).
- ✓ D401: 1N4149 diode (#56-56).

✓ Solder the leads to the foil and cut off the excess lead lengths.



START 

NOTE: To mount a resistor vertically, as in the following step, bend one lead along the side of the resistor body. Then mount the resistor over the circuit board outline and push it down against the circuit board as shown.

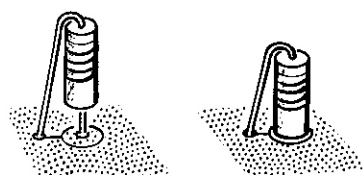

- R437: 2200 Ω (red-red-red).
- R439: 2200 Ω (red-red-red).
- R442: 2200 Ω (red-red-red).
- R422: 22 kΩ (red-red-orange).
- R425: 100 Ω (brown-black-brown).
- R419: ~~100~~ ¹⁰ kΩ (brown-black-yellow).
ORANGE
- Solder the leads to the foil and cut off the excess lead lengths.
- R421: 100 kΩ (brown-black-yellow).
- R418: 270 Ω (red-violet-brown).
- R427: 10 kΩ (brown-black-orange).
- R426: 1000 Ω (brown-black-red).
- R428: 5600 Ω (green-blue-red).
- Solder the leads to the foil and cut off the excess lead lengths.

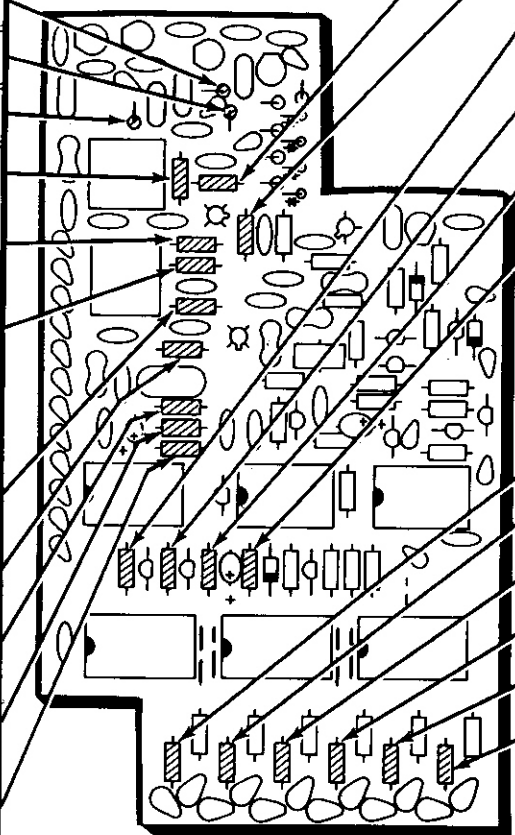

CONTINUE 

- R423: 10 kΩ (brown-black-orange).
- R424: 100 Ω (brown-black-brown).
- R454: 150 Ω (brown-green-brown).
- R452: 4700 Ω (yellow-violet-red).
- R451: 4700 Ω (yellow-violet-red).
- R431: 2200 Ω (red-red-red).
- Solder the leads to the foil and cut off the excess lead lengths.
- Install six 2200 Ω resistors (red-red-red) at the following locations:
- R404.
- R402.
- R408.
- R406.
- R413.
- R411.
- Solder the leads to the foil and cut off the excess lead lengths.

PICTORIAL 4-3

START →

Install four 100 kΩ resistors (brown-black-yellow) at the following locations:

- R434
- R436
- R438
- R441

R446: 100 Ω (brown-black-brown).

R447: ~~470~~⁸²⁰ Ω (yellow-violet-brown). *gray red brown*

R456: 4700 Ω (yellow-violet-red).

R448: 10 kΩ (brown-black-orange).

Solder the leads to the foil and cut off the excess lead lengths.

R417: 1000 Ω (brown-black-red).

R416: 22 kΩ (red-red-orange).

R432: 4700 Ω (yellow-violet-red).

Install six 2200 Ω resistors (red-red-red) at the following locations:

- R403
- R401
- R407
- R405
- R412
- R409

Solder the leads to the foil and cut off the excess lead lengths.

CONTINUE →

R435: 2200 Ω (red-red-red).

R445: ~~6000~~²²⁰⁰ Ω (*red red red* blue-gray-red).

R443: 100 kΩ (brown-black-yellow).

R444: 2200 Ω (red-red-red).

R459: 4700 Ω (yellow-violet-red).

R458: 4700 Ω (yellow-violet-red).

R457: 1000 Ω (brown-black-red).

Solder the leads to the foil and cut off the excess lead lengths.

R453: 2200 Ω (red-red-red).

R455: 4700 Ω (yellow-violet-red).

R416: 1000 Ω (brown-black-red).

R449: 18 kΩ (brown-gray-orange).

Install three 2200 Ω resistors (red-red-red) at the following locations:

- R414.
- R429.
- R433.

Solder the leads to the foil and cut off the excess lead lengths.

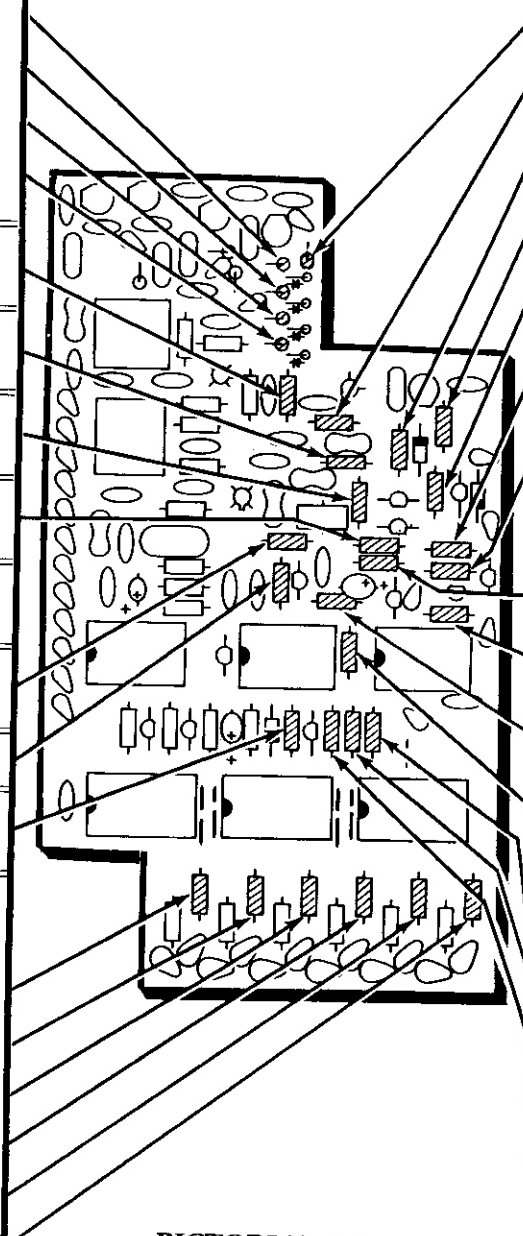

PICTORIAL 4-4

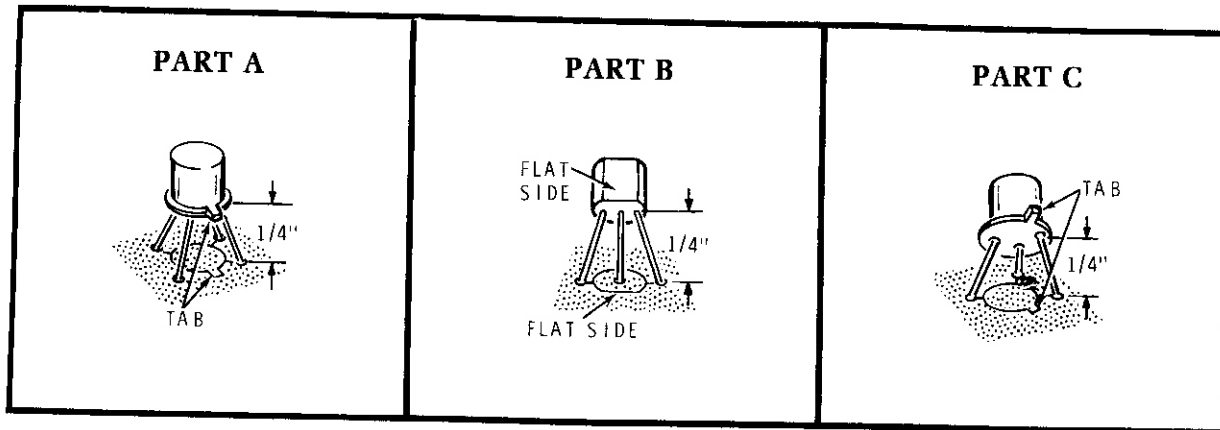

Detail 4-5A

START ▾

NOTE: When you install a transistor, line up the flat or tab on the transistor with the outline of the flat or tab on the circuit board. Then insert the leads in the corresponding holes in the circuit board. Position it 1/4" above the circuit board; then solder the leads to the foil and cut off the excess lead lengths.

(1) Q403: MRF502 transistor (#417-290). Refer to Part A of Detail 4-5A.

(L) Q402: 40673 transistor (#417-240). Refer to Part A of the Detail.

Refer to Part B of the Detail and install five MPSA20 transistors (#417-801) at the following locations:

- (L) Q401
- (L) Q404
- (L) Q408
- (L) Q407
- (L) Q405

CONTINUE ▾

(L) Q406: 2N2369 transistor (#417-154). Refer to Part C of the Detail.

Refer to Part B of the Detail and install five MPSA20 transistors (#417-801) at the following locations:

- (L) Q410.
- (L) Q411.
- (L) Q412.
- (L) Q409.
- (L) Q413.

(L) Q414: MPSA05 transistor (#417-864). Refer to Part B of the Detail.

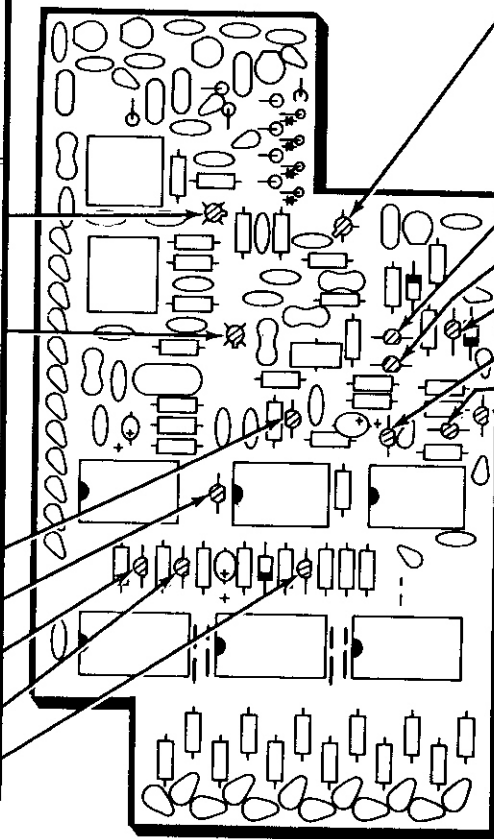

PICTORIAL 4-5

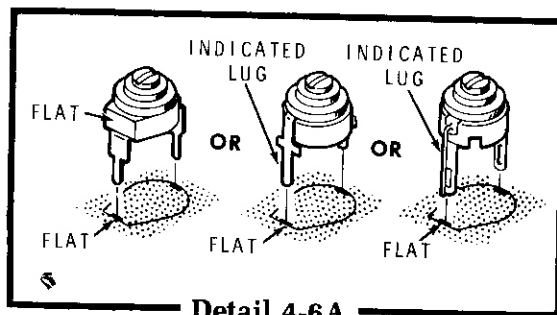

Detail 4-6A

START

NOTE: The trimmer capacitors that you will install in the following steps, can be supplied in three different styles. Refer to Detail 4-6A and install each trimmer as shown. Be sure to line up the flat on the trimmer or the indicated lug with the outline of the flat on the circuit board. Solder the lugs of each trimmer as you install it and cut off any excess lug lengths.

() C432: 3.2-18 pF trimmer (#31-71).

(✓) C428: 3.2-18 pF trimmer (#31-71).

(✓) C425: 3.2-18 pF trimmer (#31-71).

(✓) C422: 3.2-18 pF trimmer (#31-71).

(✓) C435: 3.2-18 pF trimmer (#31-71).

NOTE: The IC sockets that you will install in the following steps can be installed either way. Solder the lugs to the foil as you install each socket.

(✓) 14-pin IC socket at IC406.

(✓) 14-pin IC socket at IC405.

(✓) 14-pin IC socket at IC404.

() 16-pin IC socket at IC401.

() 16-pin IC socket at IC402.

(✓) 16-pin IC socket at IC403.

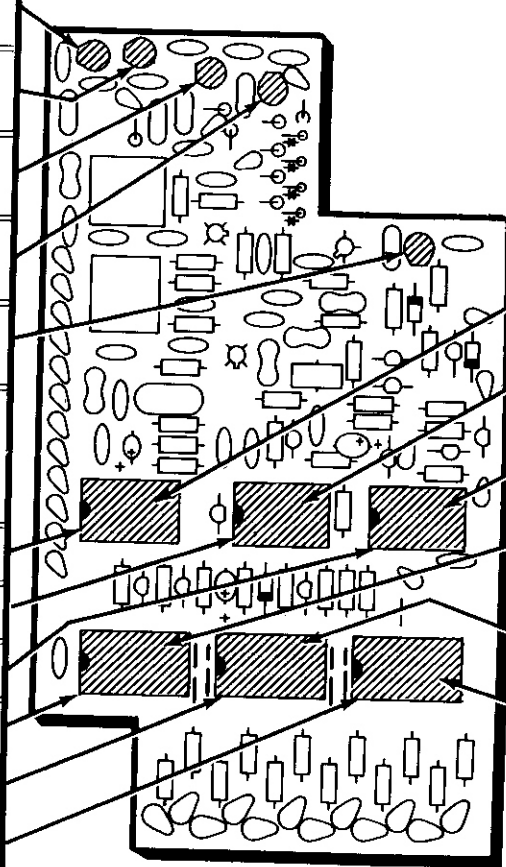

PICTORIAL 4-6

CONTINUE

NOTE: The pin 1 end of inline integrated circuits may be marked in a number of ways; with a notch, triangle, dot, the numeral 1, etc.

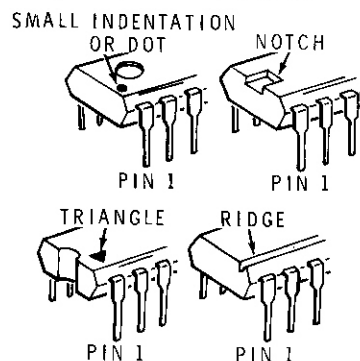

Be sure you install each IC so its pin 1 end is toward the index mark on the circuit board.

Before you apply downward pressure to an IC, make sure each pin is centered in its proper socket hole. Handle IC's with care as their pins are very easily bent.

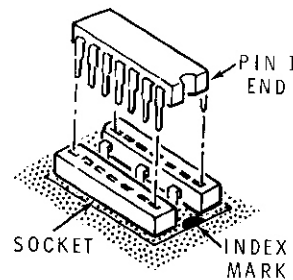

() IC406: MC4044P integrated circuit (#443-62).

(✓) IC405: SN7400N integrated circuit (#443-1).

(✓) IC404: SN7473N integrated circuit (#443-5).

() IC401: MC4016P integrated circuit (#443-61).

() IC402: MC4016P integrated circuit (#443-61).

(✓) IC403: MC4016P integrated circuit (#443-61).

START 

NOTE: When you install ceramic capacitors, do not push the insulated portions of the leads into the circuit board holes. This could make it difficult to solder the leads to the foil.

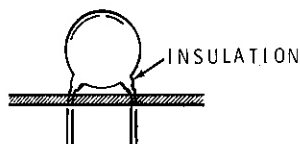

- C433: 15 pF ceramic.
- C434: .001 μ F ceramic.
- C413: 36 pF mica.
- C414: 3.3 pF ceramic.
- C412: .01 μ F ceramic.
- Solder the leads to the foil and cut off the excess lead lengths.
- C407: 3.3 pF ceramic.
- C408: 36 pF mica.
- C419: .1 μ F ceramic.
- C401: .1 μ F ceramic.
- Solder the leads to the foil and cut off the excess lead lengths.

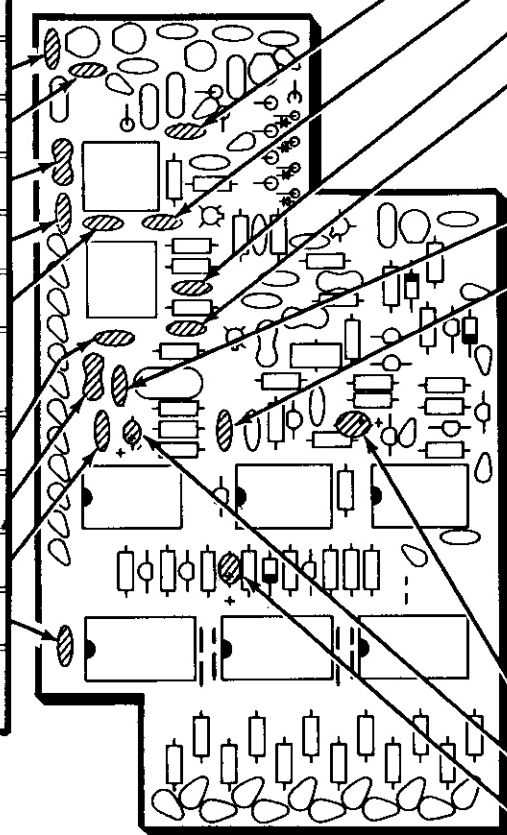

CONTINUE 

- C427: .001 μ F ceramic.
- C409: 3.3 pF ceramic.
- C406: 33 pF ceramic.
- C405: .01 μ F ceramic.
- Solder the leads to the foil and cut off the excess lead lengths.
- C444: .01 μ F ceramic.
- C418: .001 μ F ceramic.

NOTE: When you install a tantalum capacitor, always position the positive (+) or dot marked lead of the capacitor in the positive (+) marked hole.

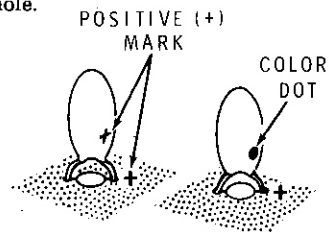

- C443: 150 μ F tantalum.
- C416: 2.2 μ F tantalum.
- C421: 10 μ F tantalum.
- Solder the leads to the foil and cut off the excess lead lengths.

PICTORIAL 4-7

START →

- (✓) C424: .001 μ F ceramic.
- (✓) C423: 15 pF ceramic.
- (✓) C426: 15 pF ceramic.
- (✓) C429: 15 pF ceramic.
- (✓) C431: .001 μ F ceramic.
- (✓) Solder the leads to the foil and cut off the excess lead lengths.
- (✓) C437: .01 μ F ceramic.
- (✓) C442: ~~20~~ 20 pF ceramic.
- (✓) C404: 180 pF mica.
- (✓) C417: .1 μ F Mylar.
- (✓) C415: .1 μ F ceramic.
- (✓) Solder the leads to the foil and cut off the excess lead lengths.

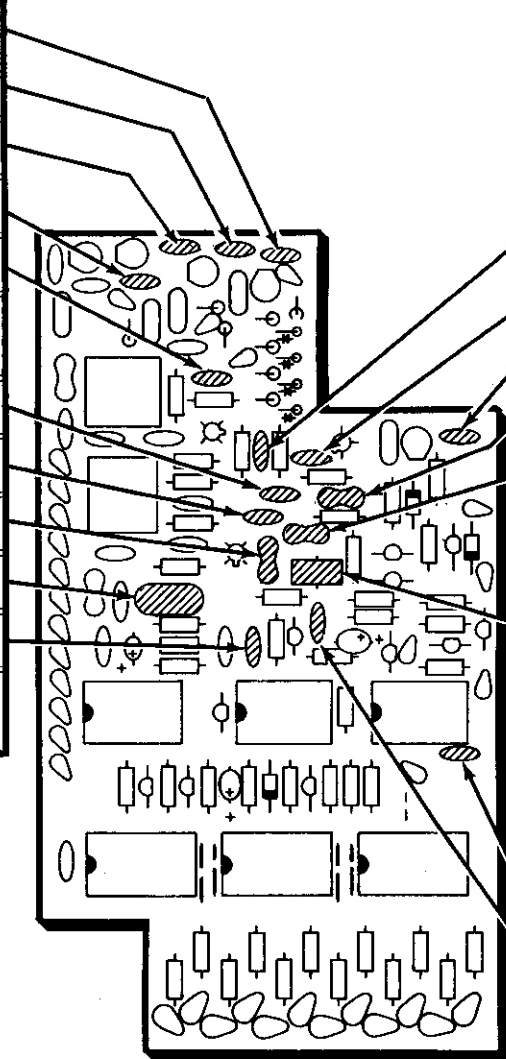

CONTINUE →

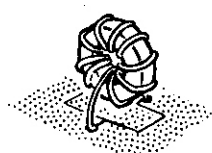
- (✓) C411: .01 μ F ceramic.
 - (✓) C441: 33 pF ceramic.
 - (✓) C436: 15 pF ceramic.
 - (✓) C439: 255 pF mica.
 - (✓) C438: 255 pF mica.
 - (✓) Solder the leads to the foil and cut off the excess lead lengths.
 - (✓) L401: 100 μ H toroid coil (#40-961). Position the coil down against the circuit board.
- 
- (✓) C402: .1 μ F ceramic.
 - (✓) C403: ~~100 pF~~ .001 μ F ceramic.
 - (✓) Solder the leads to the foil and cut off the excess lead lengths.

PICTORIAL 4-8

START →

(✓) Y401: 23.2333 MHz crystal (#404-585).

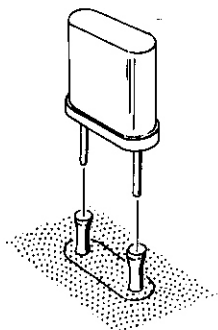

(V) Y402: 23.3333 MHz crystal (#404-586).

(✓) Y403: 23.43333 MHz crystal (#404-587).

NOTE: The following coils can be installed only one way in the circuit board. Solder the lugs to the foil and cut off the excess lug lengths as you install them.

(✓) L403: .15 μH coil (#40-1616).

(✓) L402: .16 μH coil (#40-1617).

(✓) Form a 3/4" bare wire as shown. Use a cutoff lead. Then push the wire into the wire sockets at J.

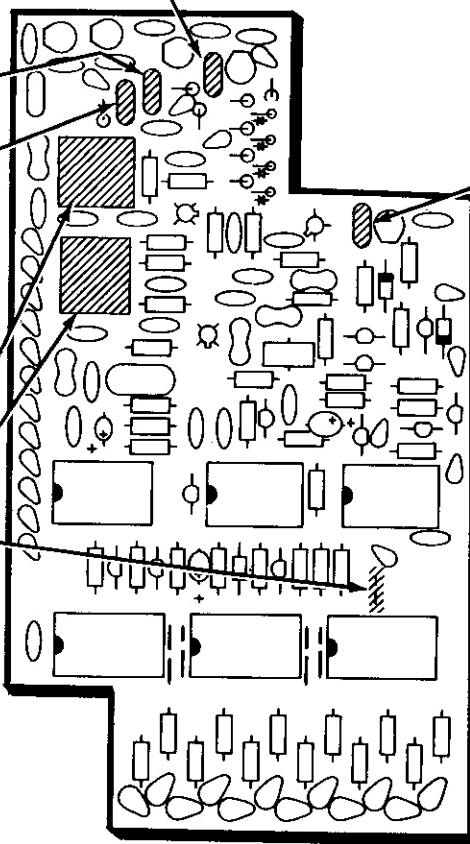
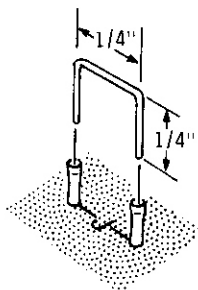

CONTINUE →

(✓) Y405: 21.55 MHz crystal (#404-584).

CIRCUIT BOARD CHECKOUT

Carefully inspect the foil side of the circuit board for the following most commonly made errors.

- (✓) Unsoldered connections (at leads that have foil).
- (✗) "Cold" solder connections.
- (✓) Solder bridges between foil patterns.
- (✗) Protruding leads which could touch together.

Refer to the illustrations where the parts were installed as you make the following visual checks.

- (✓) Transistors for proper **type** and **installation**.
- (✓) Integrated circuits for the proper **type** and **installation**.
- (✓) Electrolytic capacitors for the correct position of the positive (+) mark.
- (✓) Diodes for the correct **type** and **position** of the banded end.

PICTORIAL 4-9



INSTALLATION

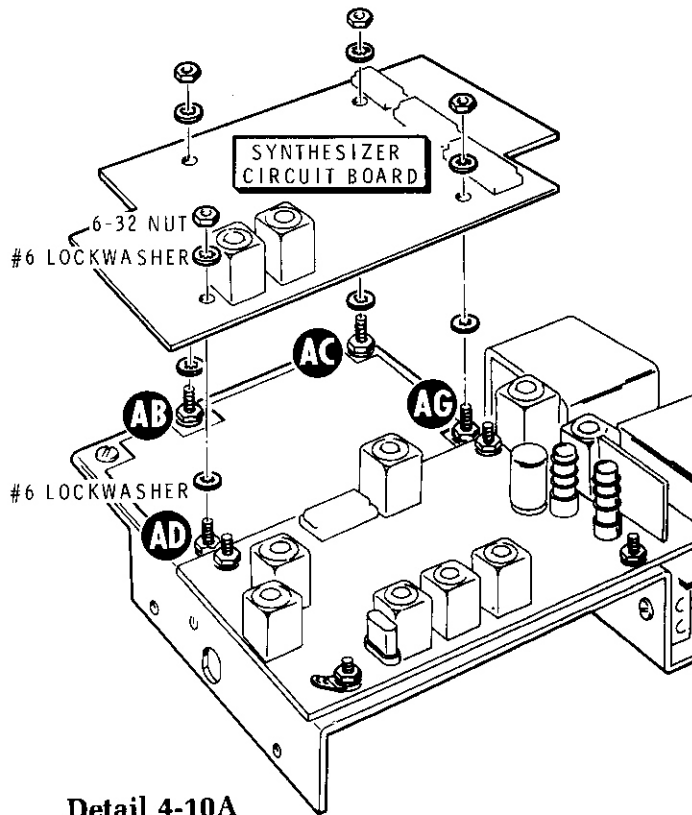

Detail 4-10A

Refer to Pictorial 4-10 (Illustration Booklet, Page 8) for the following steps.

- () Refer to Detail 4-10A and mount the synthesizer circuit board to the chassis. Use two #6 lockwashers and a 6-32 nut at AB, AC, AD, and AG.
- () Refer to Detail 4-10B and prepare a 4-1/2" shielded cable.

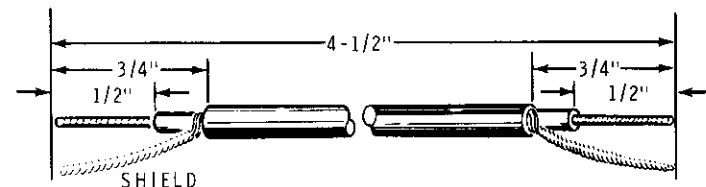

Detail 4-10B

- (✓) Install ferrite beads and PCB connectors on the inner wire at each end of the prepared cable.
- (✓) Install only PCB connectors on the shield wire at each end of the prepared cable. Be sure to use a 1/2" length of small sleeving on the shield lead.
- (✓) Cut four 5/8" lengths of medium (heat shrinkable) sleeving.
- (✓) Install a 5/8" length of sleeving on each PCB connector on the ends of the shielded cable.

Connect one end of the prepared cable to the receiver circuit board as follows:

- (✓) Inner wire to pin C.
- (✓) Shield wire to pin D.

Connect the other end of the cable to the synthesizer circuit board as follows:

- (✓) Inner wire to pin A.
- (✓) Shield wire to pin B.

Connect the free end of the shielded cable coming from the VCO assembly to the synthesizer circuit board as follows:

- (✓) Inner wire to pin C.
- (✓) Shield wire to pin D.

NOTE: When you connect wires to the edge of the synthesizer circuit board, as in the following steps, support the edge of the board to prevent the board from breaking.

Connect some of the wires coming from the lever switch assembly to the synthesizer circuit board as follows:

- (✓) Gray wire from SW3 to pin A8.



- Red wire from SW3 to pin A2.
- Gray wire from SW4 to pin B8.
- Red wire from SW4 to pin B2.
- Gray wire from SW5 to pin C8.
- Red wire from SW5 to pin C2.

Connect some of the wires coming from BO 11 of the wire harness to the synthesizer circuit board as follows:

- Yellow wire to pin T.
- Red wire to pin R.
- Orange wire to pin S.
- Brown wire to pin P.

Connect the wires coming from BO 12 of the wire harness to the synthesizer circuit board as follows:

- Gray wire to pin W.
- White-black wire to pin V.
- White wire to pin U.
- Black wire to pin N.

Refer to Pictorial 4-11 for the following steps.

Connect the remaining wires coming from the lever switch assembly to the synthesizer circuit board as follows:

- Yellow wire from SW3 to pin A4.
- Brown wire from SW3 to pin A1.
- Yellow wire from SW4 to pin B4.

- Brown wire from SW4 to pin B1.
- Yellow wire from SW5 to pin C4.
- Brown wire from SW5 to pin C1.

Prepare a 4-1/2" small red wire.

Install a PCB connector on one end of the 4-1/2" red wire.

Cut a 5/8" length of medium (heat shrinkable) sleeving and install it on the PCB connector on the red wire.

Connect the free end of the red wire to switch SW6 lug 1 (S-1). Connect the other end to pin X on the synthesizer circuit board.

Connect the wires coming from BO 10 of the wire harness to the synthesizer circuit board as follows:

- White-orange wire to pin E.
- Orange wire to pin F.
- Red wire to pin J.
- White-brown wire to pin M.

Connect the wires coming from BO 9 of the wire harness to the synthesizer circuit board as follows:

- Blue cable inner lead to pin G.
- Blue cable shield lead to pin H.
- Orange cable inner lead to pin K.
- Orange cable shield lead to pin L.

Position the wire harness down against the receiver circuit board and route the wires as shown.

Set the chassis aside until it is called for in a step.



TRANSMITTER CIRCUIT BOARD

PARTS LIST

- () Refer to the Pack Index Sheet and locate Pack #4.
- () Unpack these parts and check each part against the following list. The key numbers correspond to the numbers on the "Transmitter Circuit Board Parts Pictorial" (Illustration Booklet, Page 9).

To order a replacement part, always include the PART NUMBER. Use the Parts Order Form furnished with this kit. If one is not available, see "Replacement Parts" inside the rear cover of this Manual. For price information, refer to the separate "Heath Parts Price List."

KEY No.	HEATH Part No.	QTY.	DESCRIPTION	CIRCUIT Comp. No.
---------	----------------	------	-------------	-------------------

RESISTORS

NOTES:

- Resistors may be packed in more than one envelope. Open all of the resistor envelopes in this pack before you check them against the following list.
- The following resistors have a tolerance of 10% unless otherwise noted. 10% is indicated by a fourth color band of silver; 5% is indicated by a gold fourth band.

1/4-Watt

A1	1-55-12	1	10 Ω , 5% (brown-black-black)	R109
A1	1-20-12	2	33 Ω (orange-orange-black)	R101, R104
A1	1-107-12	1	82 Ω , 5% (gray-red-black)	R106
A1	1-1-12	2	100 Ω (brown-black-brown)	R116, R131
A1	1-37-12	1	150 Ω (brown-green-brown)	R137
A1	1-17-12	1	220 Ω (red-red-brown)	R103

KEY No.	HEATH Part No.	QTY.	DESCRIPTION	CIRCUIT Comp. No.
---------	----------------	------	-------------	-------------------

Resistors (cont'd.)

A1	1-67-12	2	680 Ω , 5% (blue-gray-brown)	R136, R138
A1	1-4-12	1	2200 Ω (red-red-red)	R111
A1	1-8-12	2	4700 Ω (yellow-violet-red)	R112, R117
A1	1-80-12	3	10 k Ω , 5% (brown-black-orange)	R108, R114, R115
A1	1-108-12	4	15 k Ω , 5% (brown-green-orange)	R102, R121, R122, R123
A1	1-45-12	2	22 k Ω (red-red-orange)	R124, R135
A1	1-46-12	1	27 k Ω (red-violet-orange)	R105
A1	1-32-12	2	100 k Ω (brown-black-yellow)	R132, R133
A1	1-33-12	2	120 k Ω (brown-red-yellow)	R113, R118
A1	1-18-12	1	470 k Ω (yellow-violet-yellow)	R134

1/2-Watt

A2	1-62	1	51 Ω , 5% (green-brown-black)	R139
A2	1-112	1	180 Ω , 5% (brown-gray-brown)	R141
A3	4-18	1	3300 Ω , 5% (orange-orange-red)	R129
A3	4-25	1	27 k Ω , 5% (red-violet-orange)	R128



KEY No.	HEATH Part No.	QTY.	DESCRIPTION	CIRCUIT Comp. No.
---------	----------------	------	-------------	-------------------

CAPACITORS**Ceramic**

B1	21-33	1	3.3 pF	C114
B1	21-168	1	4.7 pF	C121
B1	21-61	2	6.8 pF	C101, C119
B1	21-3	2	10 pF	C115, C143
B1	21-111	2	15 pF	C107, C109
B1	21-167	1	39 pF	C122
B1	21-147	2	47 pF	C102, C103
B1	21-85	1	56 pF	C125
B1	21-17	4	270 pF	C116, C127, C156, C157
B1	21-163	7	.001 μ F	C111, C113, C118, C124, C133, C134, C135
B1	21-176	11	.01 μ F	C104, C105, C106, C112, C117, C126, C128, C131, C138, C141, C142
B1	21-143	3	.05 μ F	C136, C151, C153
B1	21-95	2	.1 μ F	C149, C154

Electrolytic

B2	25-200	2	.68 μ F (tantalum)	C139, C145
B2	25-220	1	10 μ F (tantalum)	C129
B3	25-145	1	25 μ F	C155
B3	25-241	1	1200 μ F	C152

Other

B4	27-129	1	.047 μ F Mylar	C132
B4	27-77	1	.1 μ F Mylar	C137
B5	28-3	1	.56 pF phenolic (green-blue-gray-silver)	C123
B5	28-2	3	1 pF phenolic (brown-black-white-silver)	C108, C146, C148
B6	31-57	2	2.7-20 pF trimmer	C144, C147

KEY No.	HEATH Part No.	QTY.	DESCRIPTION	CIRCUIT Comp. No.
---------	----------------	------	-------------	-------------------

INDUCTORS

C1	40-1633	1	.07 μ F coil (blue)	L107
C1	40-1632	2	.104 μ H coil (yellow)	L105, L106
C1	40-1631	2	.25 μ H coil (red)	L103, L104
C2	40-1630	2	.975 μ H coil (clear)	L101, L102
C3	45-85	1	.16 mH choke	L108
C4	475-10	2	1.07 μ H ferrite bead	FB101, FB102

DIODES

D1	56-57	1	1N716A	ZD101
D1	57-27	1	1N2071	D102
D1	56-56	1	1N4149	D101

TRANSISTORS — INTEGRATED CIRCUITS (IC's)

NOTE: Transistors and integrated circuits may be marked for identification in any of the following four ways:

1. Part number.
2. Type number. (On integrated circuits, this refers only to the numbers; the letters may be different or missing.)
3. Part number and type number.
4. Part number and a type number other than the one listed.

E1	417-290	1	MRF502 transistor	Q101
E2	417-293	1	2N5770 transistor	Q102
E3	417-205	1	2N3866 transistor	Q103
E4	417-175	1	2N5294 transistor	Q104
E5	442-21	1	MC1458 or NE5558V IC	IC101
E5	442-53	1	NE555V IC	IC102
E6	443-1	1	SN7400N IC	IC103
E6	443-7	3	SN7490N IC	IC105, IC106, IC107
E6	443-34	1	SN7492N IC	IC104
E7	442-54	1	UA7805 IC	IC1

KEY No.	HEATH Part No.	QTY.	DESCRIPTION
---------	----------------	------	-------------

CIRCUIT Comp. No.

KEY No.	HEATH Part No.	QTY.	DESCRIPTION
---------	----------------	------	-------------

CIRCUIT Comp. No.

CONNECTOR — SOCKETS

F1	432-121	29	Small PCB pin (2 extra)
F2	432-772	4	Large PCB pin
F3	432-865	1	Connector housing
F4	432-866	3	Connector pin
F5	434-230	2	8-pin IC socket
F6	434-298	5	14-pin IC socket
F7	432-790	1	Plastic sleeve
F8	432-73	1	Female terminal

HARDWARE

G1	250-213	1	4-40 × 5/16" screw
G2	250-52	1	4-40 × 1/4" screw
G3	252-2	1	Large 4-40 nut
G4	252-15	1	Small 4-40 nut
G5	254-9	2	#4 lockwasher
G6	252-3	5	6-32 nut
G7	254-1	9	#6 lockwasher
G8	259-1	2	#6 solder lug

MISCELLANEOUS

H1	10-312	1	10 kΩ control	R119
H2	10-353	3	100 kΩ control	R125, R126, R127
H3	75-159	1	Transistor spacer	
H4	75-704	1	Transistor insulator (packed between two pieces of cardboard.)	
H5	434-146	2	Phono jack	J101, J102
H6	421-32	1	5-ampere, 3AG fuse	F1
H7	75-24	1	Strain relief	
H8	404-426	1	10 MHz crystal	Y101

PARTS FROM THE MAIN PACK

	85-1879-5	1	Transmitter circuit board	
J1	490-1	1	Alignment tool	

STEP-BY-STEP ASSEMBLY

START

(✓) Position the transmitter circuit board as shown. Then complete the steps in the following Pictorials.

NOTE: There are 27 locations on this circuit board where you will install small PCB (printed circuit board) pins. Sixteen of these locations are marked with a letter; A, B, C, etc.; eight locations are marked TP101 through TP108 and three locations are marked IN, OUT, and GND. Insert all of the pins from the lettered side of the board. Then turn the board over and solder the pins to the foil.

(✓) Install small PCB pins (#432-121) at the 27 locations shown in this Pictorial. Be sure each pin is straight and pressed in until the stop ridge is against the circuit board. Do not install pins at G, P, R, or V at this time.

TURN BOARD OVER AND SOLDER TO FOIL

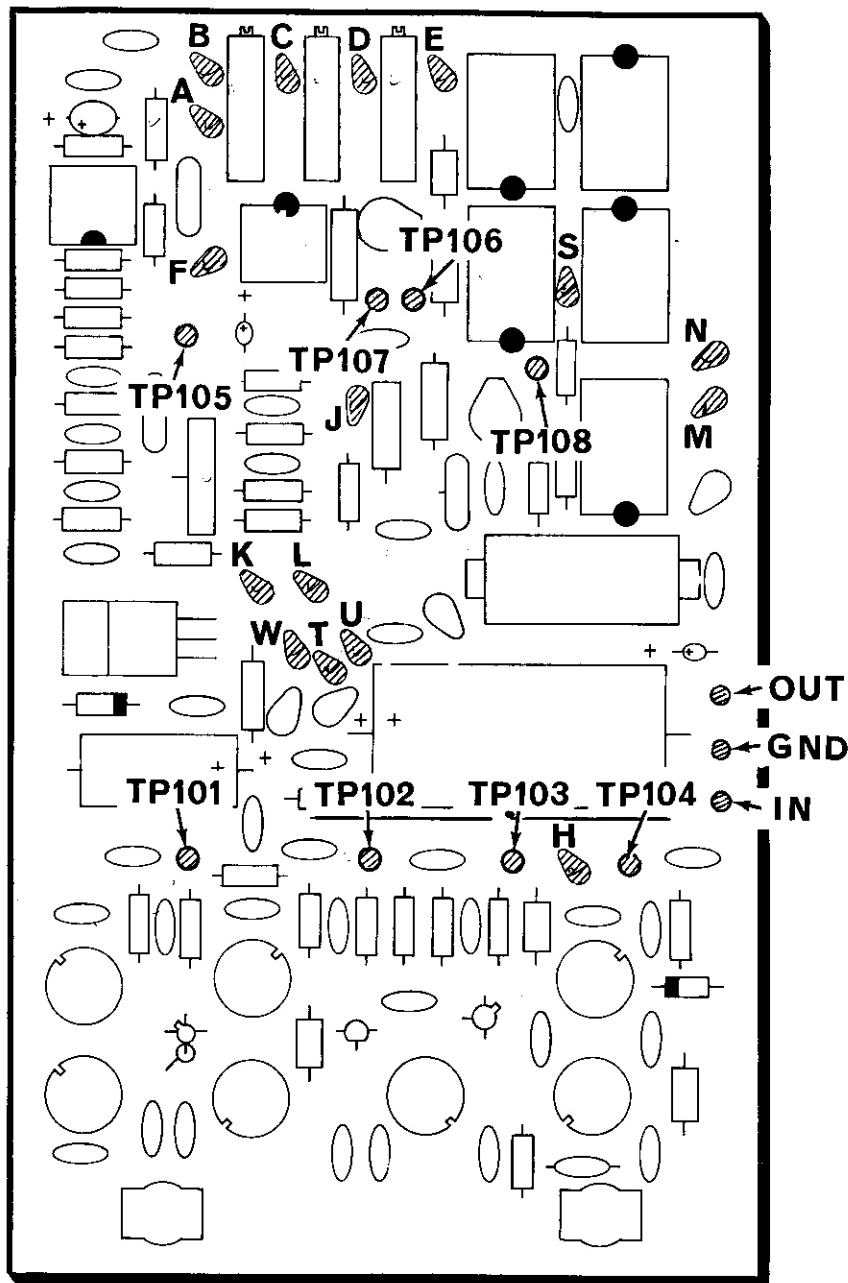
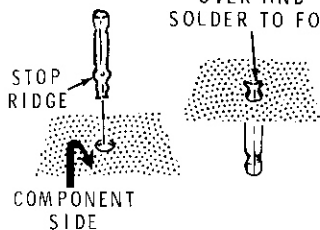

PICTORIAL 5-1

START →

(✓) Position the transmitter circuit board as shown. Then perform the steps in the following Pictorials.

- (✓) R115: 10 kΩ (brown-black-orange).
- (✓) R117: 4700 Ω (yellow-violet-red).
- (✓) R114: 10 kΩ (brown-black-orange).
- (✓) R118: 120 kΩ (brown-red-yellow).
- (✓) R116: 100 Ω (brown-black-brown).
- (✓) R121: 15 kΩ (brown-green-orange).
- (✓) R122: 15 kΩ (brown-green-orange).
- (✓) Solder the leads to the foil and cut off the excess lead lengths.
- (✓) R123: 15 kΩ (brown-green-orange).
- (✓) R124: 22 kΩ (red-red-orange).

NOTE: When you install a diode, always match the band on the diode with the band mark on the circuit board. A DIODE WILL NOT WORK IF INSTALLED BACKWARDS. See Detail 5-2A.

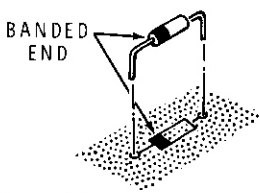

- (✓) ZD101: 1N716A diode (#56-57).
- (✓) D102: 1N2071 diode (#57-27).
- (✓) R103: 220 Ω (red-red-brown).
- (✓) R102: 15 kΩ (brown-green-orange).
- (✓) Solder the leads to the foil and cut off the excess lead lengths.

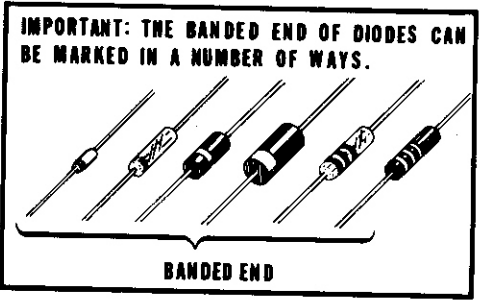

Detail 5-2A

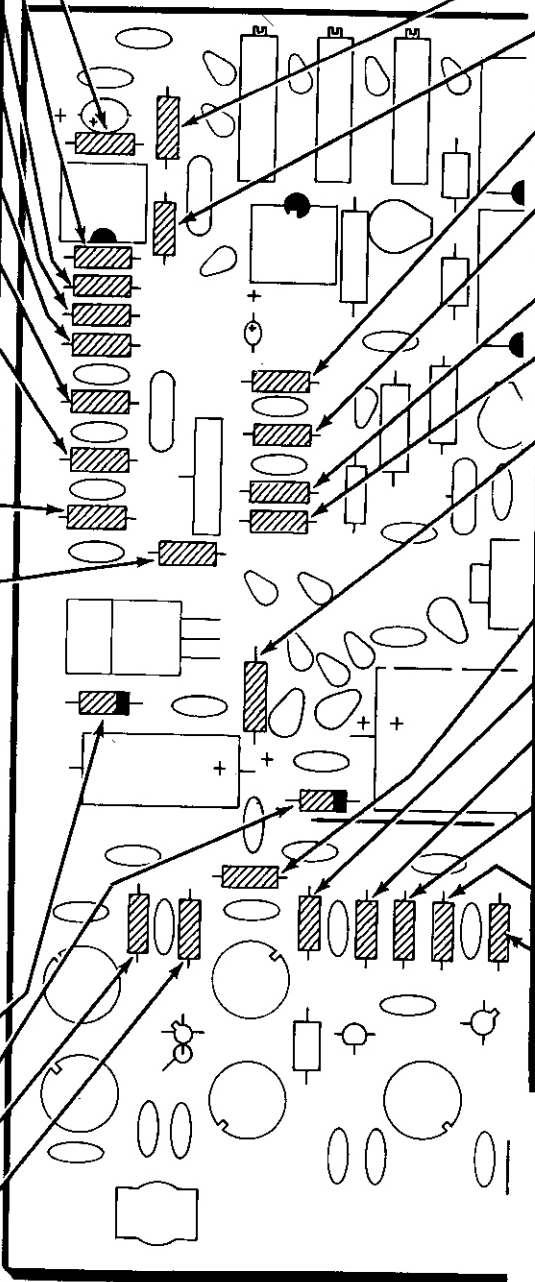

PICTORIAL 5-2

CONTINUE →

- (✓) R112: 4700 Ω (yellow-violet-red).
- (✓) R113: 120 kΩ (brown-red-yellow).
- (✓) R132: 100 kΩ (brown-black-yellow).
- (✓) R133: 100 kΩ (brown-black-yellow).
- (✓) R134: 470 kΩ (yellow-violet-yellow).
- (✓) R135: 22 kΩ (red-red-orange).
- (✓) R141: 180 Ω, 1/2-watt (brown-gray-brown). NOTE: Your circuit board may be screened 680.
- (✓) Solder the leads to the foil and cut off the excess lead lengths.
- (✓) R101: 33 Ω (orange-orange-black).
- (✓) R106: 82 Ω (gray-red-black).
- (✓) R105: 27 kΩ (red-violet-orange).
- (✓) R104: 33 Ω (orange-orange-black).
- (✓) R109: 10 Ω (brown-black-black).
- (✓) R108: 10 kΩ (brown-black-orange).
- (✓) Solder the leads to the foil and cut off the excess lead lengths.

START

- () R128: 27 k Ω , 1/2-watt (red-violet-orange).
 - (✓) R139: 51 Ω , 1/2-watt (green-brown-black).
 - () R129: 3300 Ω , 1/2-watt (orange-orange-red).
 - (✓) R131: 100 Ω (brown-black-brown).
 - (✓) Prepare a 2-3/8" gray stranded wire.
 - () 2-3/8" gray stranded wire.
 - (✓) FB102: Ferrite bead. Use a 1" length of bare wire.
 - (✓) C108: 1 pF phenolic (brown-black-white-silver).
 - (✓) Solder the leads to the foil and cut off the excess lead lengths.
 - (✓) Cut an 8" length of magnet wire and scrape 3/8" of insulation from each wire end. Then apply a small amount of solder to the bare wire ends.
 - (✓) Use the SHORTER end of the alignment tool and wind the 8" length of magnet wire into a closewound 14-turn coil. Do not wind the solder-covered lead ends.
-
- (✓) Form the two coil leads so they point straight down as shown.
-
- (✓) L109: Mount the coil. Leave 1/16" clearance between the coil body and the circuit board. Solder the leads to the foil and cut off the excess lead lengths.

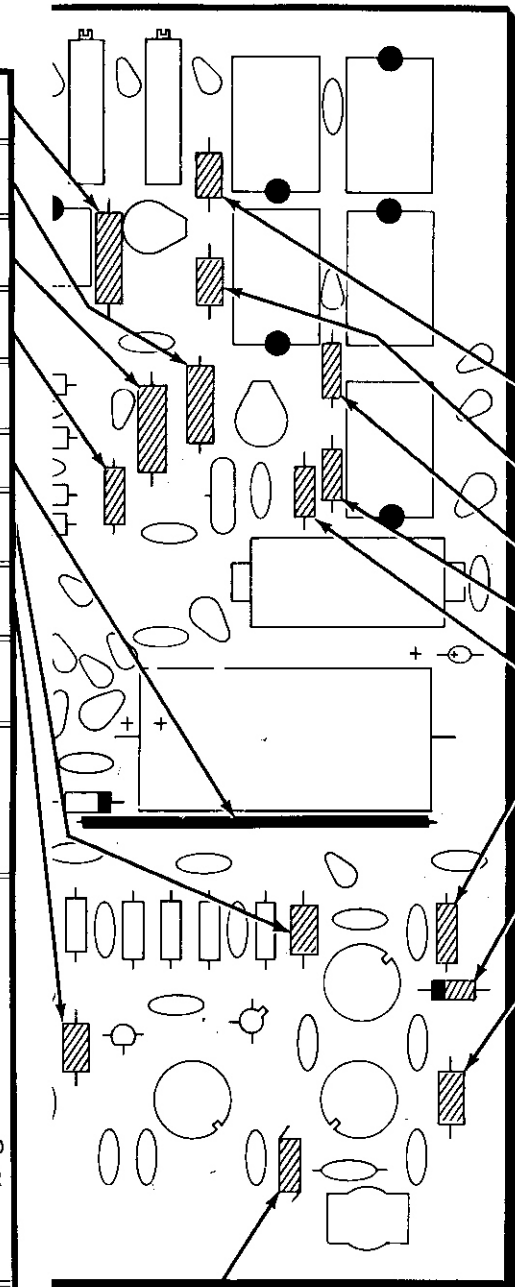

CONTINUE

- (✓) C146: 1 pF phenolic (brown-black-white-silver).
- (✓) C148: 1 pF phenolic (brown-black-white-silver).
- (✓) R138: 680 Ω (blue-gray-brown).
- (✓) R136: 680 Ω (blue-gray-brown).
- (✓) R137: 150 Ω (brown-green-brown).
- (✓) R111: 2200 Ω (red-red-red).
- (✓) D101: 1N4149 diode (#56-56). Be sure to position the band on the diode as shown on the circuit board.
- (✓) C123: .56 pF phenolic (green-blue-gray-silver).
- (✓) Solder the leads to the foil and cut off the excess lead lengths.

PICTORIAL 5-3

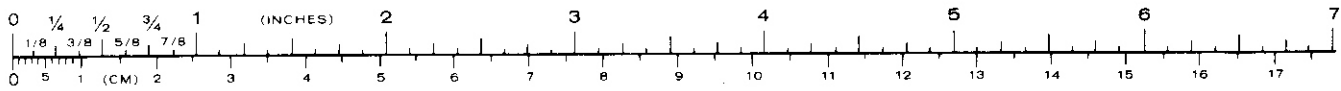

START

NOTE: When you install ceramic capacitors, do not push the insulated portions of the leads into the circuit board holes. This could make it difficult to solder the leads to the foil.

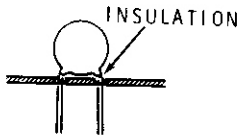

() C127: 270 pF ceramic.

() C128: .01 μ F ceramic.

() C137: .1 μ F Mylar.

() C131: .01 μ F ceramic.

() C133: .001 μ F ceramic.

() C134: .001 μ F ceramic.

() C135: .001 μ F ceramic.

(✓) Solder the leads to the foil and cut off the excess lead lengths.

() C154: .1 μ F ceramic.

() C105: .01 μ F ceramic.

() C107: .01 μ F ceramic.

() C103: 47 pF ceramic.

() C101: 6.8 pF ceramic.

() C102: 47 pF ceramic.

(✓) Solder the leads to the foil and cut off the excess lead lengths.

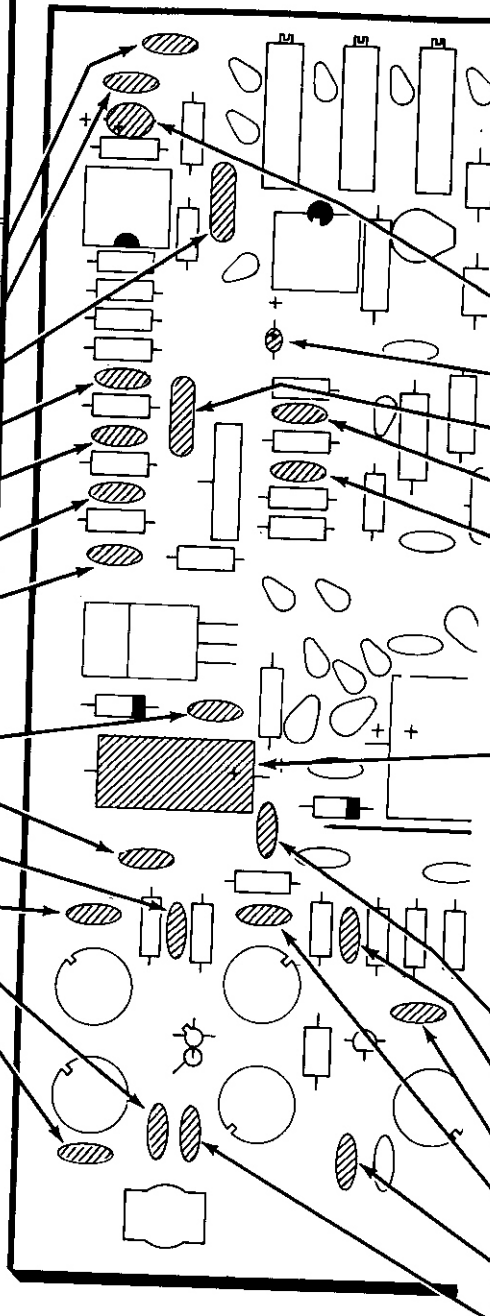
**CONTINUE**

NOTE: When you install a tantalum capacitor, always position the positive (+) or dot marked lead of the capacitor in the positive (+) marked hole.

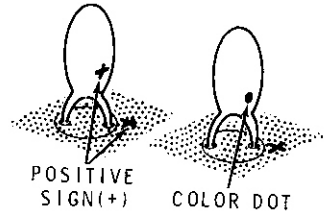

POSITIVE
SIGN(+)

COLOR DOT

() C129: 10 μ F tantalum.

() C139: .68 μ F tantalum.

() C132: .047 μ F Mylar.

() C141: .01 μ F ceramic.

() C142: .01 μ F ceramic.

() C155: 25 μ F electrolytic. Be sure to install this capacitor with the positive (+) marked lead toward the positive (+) mark on the circuit board.

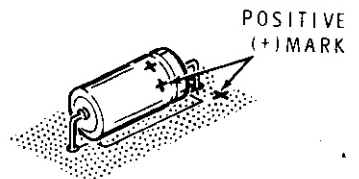

POSITIVE
(+) MARK

() Solder the leads to the foil and cut off the excess lead lengths.

() C156: 270 pF ceramic.

() C113: .001 μ F ceramic.

() C115: 10 pF ceramic.

() C104: .01 μ F ceramic.

() C109: 15 pF ceramic.

() C107: 15 pF ceramic.

(✓) Solder the leads to the foil and cut off the excess lead lengths.

PICTORIAL 5-4

START ↘

- (✓) C147: 2.7-20 pF trimmer. Solder the lugs to the foil.
- (✓) C144: 2.7-20 pF trimmer. Solder the lugs to the foil.
- (✓) Y101: 10 MHz crystal (404-426).
- (✓) C136: .05 μF ceramic.
- (✓) C157: 270 pF ceramic.
- (✓) C153: .05 μF ceramic.
- (✓) Solder the leads to the foil and cut off the excess lead lengths.
- (✓) C112: .01 μF ceramic.
- (✓) C117: .01 μF ceramic.
- (✓) C118: .001 μF ceramic.
- (✓) C119: 6.8 pF ceramic.
- (✓) C111: .001 μF ceramic.
- (✓) C114: 3.3 pF ceramic.
- (✓) Solder the leads to the foil and cut off the excess lead lengths.

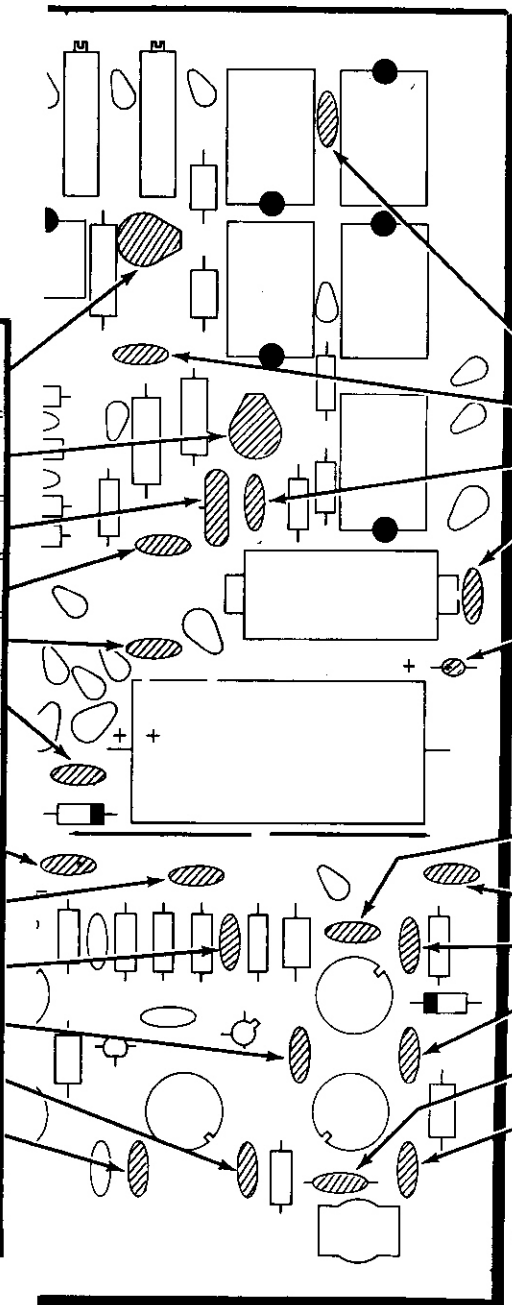

CONTINUE ↘

- (✓) C149: .1 μF ceramic.
- (✓) C138: .01 μF ceramic.
- (✓) C143: 10 pF ceramic.
- (✓) C151: .05 μF ceramic.
- (✓) C145: .68 μF tantalum. Be sure to position the positive (+) or dot marked lead toward the positive (+) mark on the circuit board.
- (✓) Solder the leads to the foil and cut off the excess lead lengths.
- (✓) C126: .01 μF ceramic.
- (✓) C124: .001 μF ceramic.
- (✓) C116: 270 pF ceramic.
- (✓) C121: 4.7 pF ceramic.
- (✓) C125: 56 pF ceramic.
- (✓) C122: 39 pF ceramic.
- (✓) Solder the leads to the foil and cut off the excess lead lengths.

PICTORIAL 5-5

START →

NOTE: To avoid possible damage to the transistor in the following steps, **DO NOT** bend or spread the broad portion of the leads. To fit the transistor to the circuit board you must bend and spread **ONLY** the narrow portion of the leads.

(✓) Q104: Install a 2N5294 transistor (#417-175) as follows:

1. Hold the wide part of the transistor leads with long-nose pliers to prevent any bending where the leads enter the transistor body. Then bend the narrow part of the leads straight down as shown.
2. Mount the transistor with 4-40 x 1/4" hardware and a transistor insulator as shown. Place the insulator between the transistor and the circuit board. Do not let the transistor twist when you tighten the hardware.
3. Turn the circuit board over, solder the leads to the foil, and cut off the excess lead lengths.

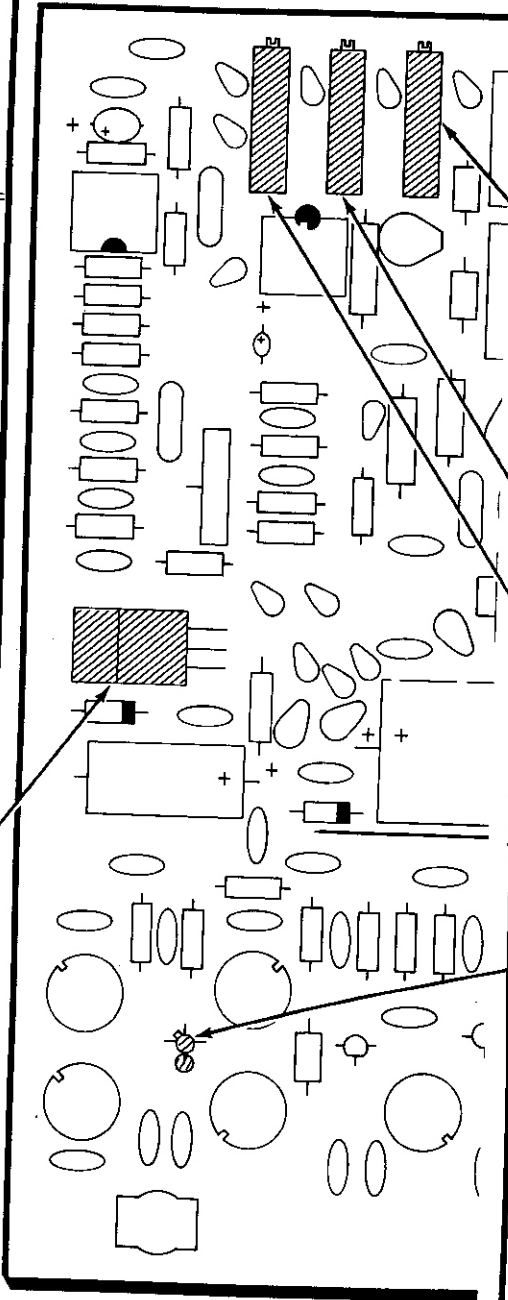
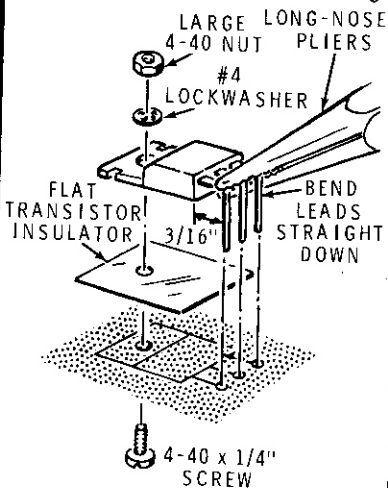

CONTINUE →

(✓) R127: 100 kΩ control. Position the screw end as shown; then mount the control on the circuit board. Press the control firmly against the circuit board. Solder the lugs to the foil and cut off the excess lug lengths.

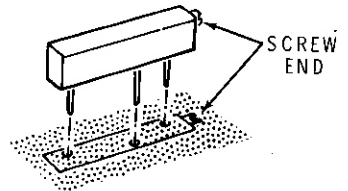

(✓) R126: 100 kΩ control. Solder the lugs to the foil and cut off the excess lug lengths.

(✓) R125: 100 kΩ control. Solder the lugs to the foil and cut off the excess lug lengths.

(✓) Q101/FB101: Refer to the illustration below and slide a 1.07 μH ferrite bead onto the base (B) lead of an MRF502 transistor (#417-290). Then line up the tab on the transistor with the outline of the tab on the circuit board and insert the leads into their corresponding holes in your circuit board. Solder the leads to the foil and cut off the excess lead lengths.

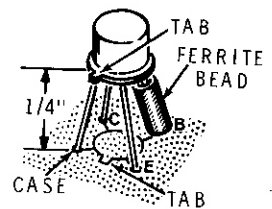

PICTORIAL 5-6

START

NOTE: The IC sockets that you will install in the next two steps may be installed either way in the circuit board.

(✓) 8-pin IC socket at IC101. Solder the pins to the foil.

(✓) 8-pin IC socket at IC102. Solder the pins to the foil.

(✓) R119: 10 kΩ control. Push the control down firmly against the circuit board. Then solder the lugs to the foil.

(✓) Q102: 2N5770 transistor (#417-293). First bend the center lead toward the flat side of the transistor. Then line up the flat on the transistor with the outline of the flat on the circuit board and insert the leads into their corresponding holes. Solder the leads to the foil and cut off the excess lead lengths.

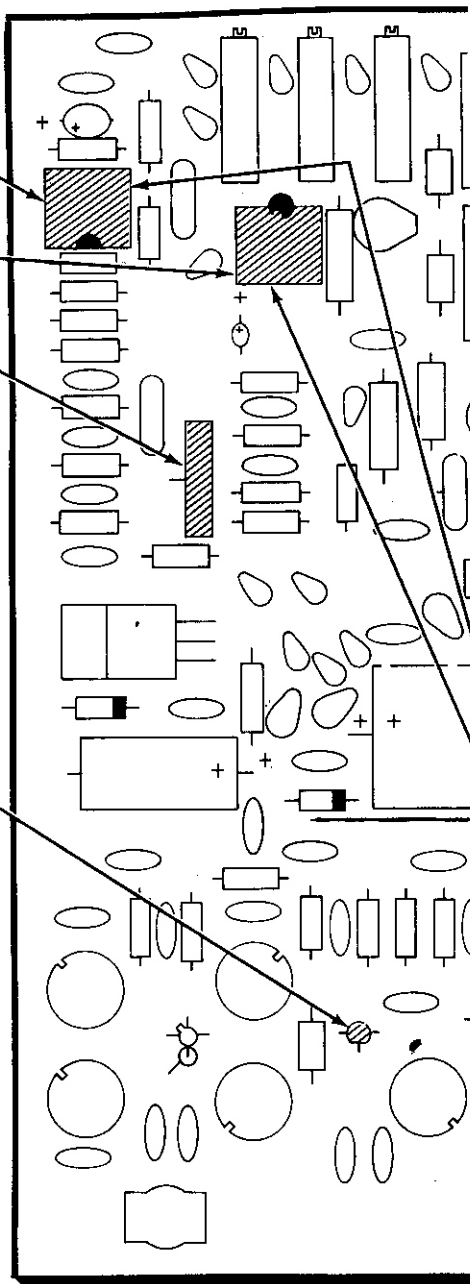
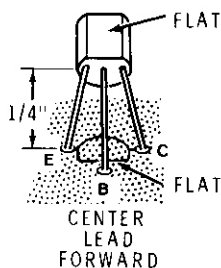

CONTINUE

NOTE: The pin 1 end of inline integrated circuits may be marked in a number of ways; with a notch, triangle, dot, the numeral 1, etc.

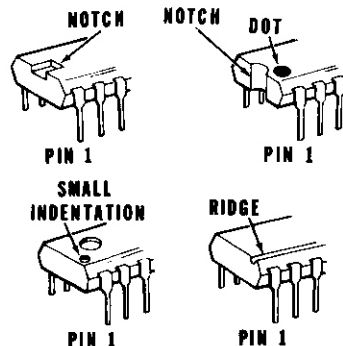

Be sure you install each IC so its pin 1 end is toward the index mark on the circuit board.

Before you apply downward pressure to an IC, make sure each pin is centered in its proper socket hole. Handle IC's with care as their pins are very easily bent.

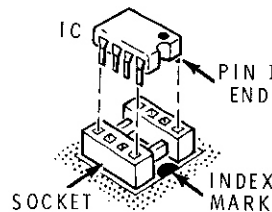

(✓) IC101: MC1458 integrated circuit (#442-21).

(✓) IC102: NE555 integrated circuit (#442-53).

PICTORIAL 5-7

START →

- (✓) 14-pin IC socket at IC105. Solder the pins to the foil.
- (✓) IC105: SN7490N integrated circuit (#443-7). Be sure to match the pin 1 end of the IC with the index mark on the circuit board.
- (✓) 14-pin IC socket at IC104. Solder the pins to the foil.
- (✓) IC104: SN7490N integrated circuit (#443-7).
- (✓) Large PCB pin at P. Solder the pin to the foil.
- (✓) Large PCB pin at V. Solder the pin to the foil.
- (✓) Large PCB pin at R. Solder the pin to the foil.
- (✓) Q103: 2N3866 transistor (#417-205). First place a transistor spacer on the leads. Then line up the tab on the transistor with the outline of the tab on the circuit board and insert the leads into their corresponding holes in the circuit board. Push the transistor and spacer down firmly against the circuit board. Then solder the leads to the foil and cut off the excess lead lengths.

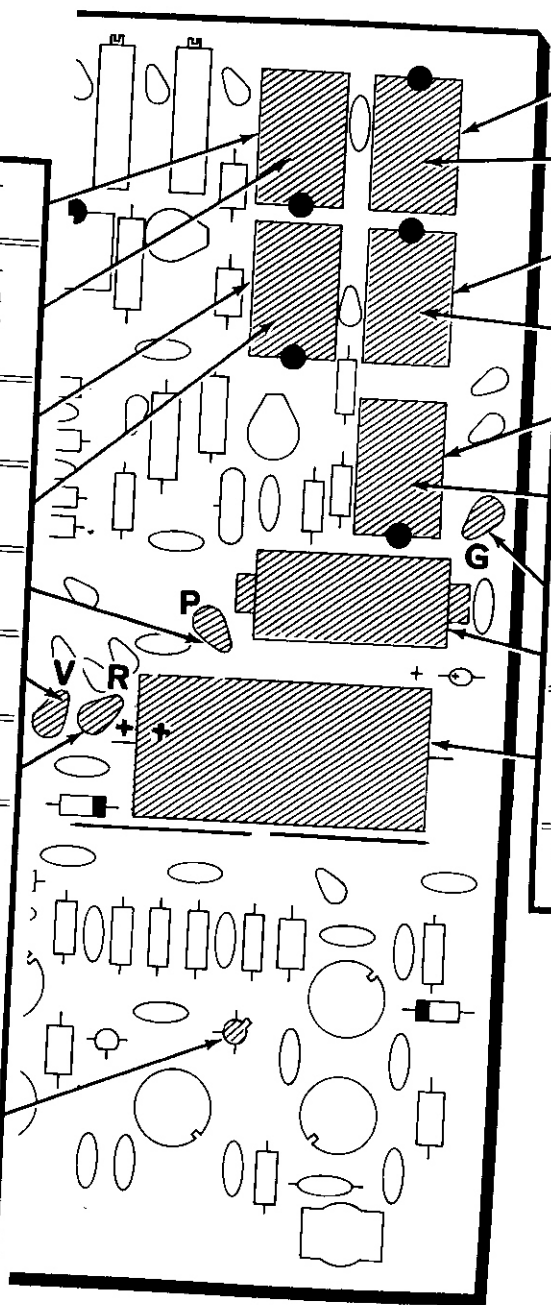
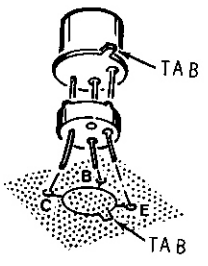

CONTINUE →

- (✓) 14-pin IC socket at IC106. Solder the pins to the foil.
- (✓) IC106: SN7490N integrated circuit (#443-7).
- (✓) 14-pin IC socket at IC107. Solder the pins to the foil.
- (✓) IC107: SN7492N integrated circuit (#443-34).
- (✓) 14-pin IC socket at IC103. Solder the pins to the foil.
- (✓) IC103: SN7400N integrated circuit (#443-1).
- (✓) Large PCB pin at G. Solder the pin to the foil.
- (✓) L108: .16 mH choke (#45-85).
- (✓) C152: 1200 μ F electrolytic. Be sure to position the positive (+) marked lead toward the positive (+) mark on the circuit board.
- (✓) Solder the leads to the foil and cut off the excess lead lengths.

PICTORIAL 5-8

START →

NOTE THE CHANGED POSITION OF THE CIRCUIT BOARD.

NOTE: When you install each of the following coils, be sure to position the notch in the coil base over the outline of the notch on the circuit board. Install the coil; then solder the pins to the foil and cut off the excess pin lengths.

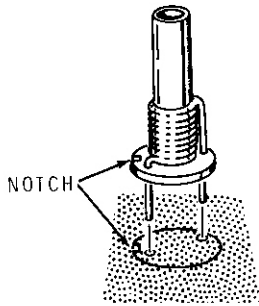

() L106: .104 μ H coil (yellow, #40-1632).

() L103: .25 μ H coil (red, #40-1631).

() L102: .975 μ H coil (clear, #40-1630).

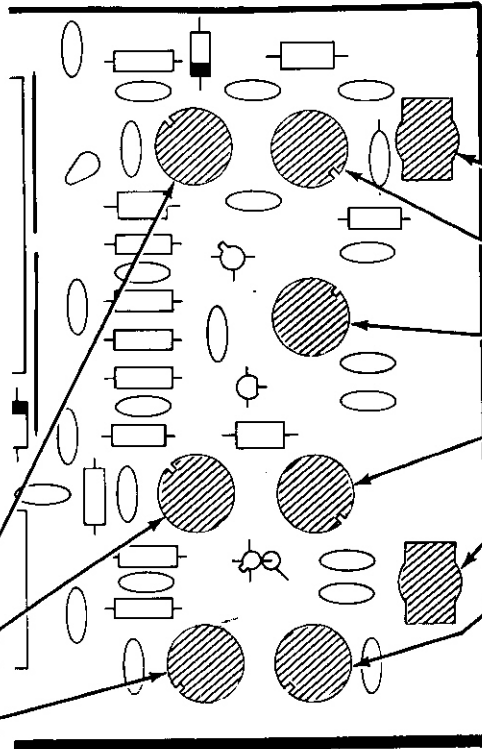
**CONTINUE** →

() J102: Phono jack. Solder the lugs to the foil.

() L107: .07 μ H coil (blue, #40-1633).

() L105: .104 μ H coil (yellow, #40-1632).

() L104: .25 μ H coil (red, #40-1631).

() J101: Phono jack. Solder the lugs to the foil.

() L101: .975 μ H coil (clear, #40-1630).

PICTORIAL 5-9

START

(✓) Cut 3" lengths (one each) of small red, brown, and yellow stranded wire.

(✓) Remove 1/8" of insulation from one end and 1/4" of insulation from the other end of each wire.

(✓) Twist together the strands and apply a small amount of solder to the wire ends to hold the strands together.

(✓) Refer to the following drawing and install a connector pin (#432-866) on the 1/8" end of each wire as shown.

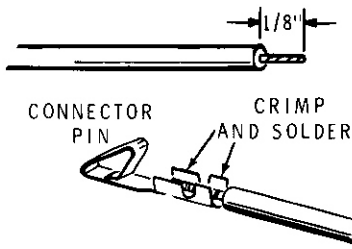

NOTE: When you perform the following step, be sure to position the connector housing and connector pins as shown before you insert the pins into the housing. Push in on the wire until the pin snaps into place.

(✓) Refer to the following drawing and insert the connector pin on the red wire into hole 1 of the connector housing.

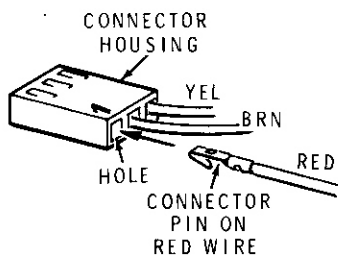

(✓) In a like manner, insert the brown and yellow wires into the indicated holes in the connector housing.

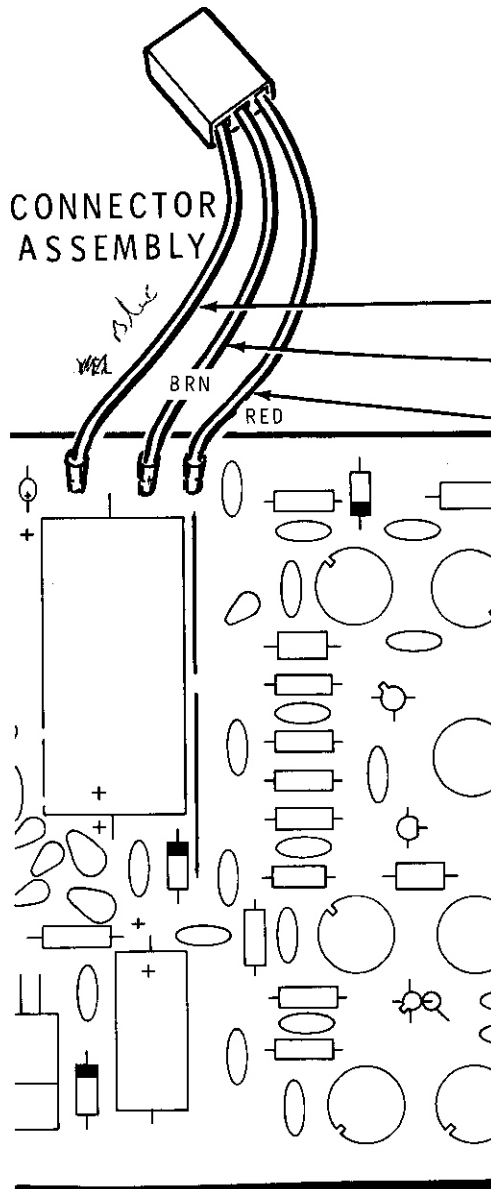
CONNECTOR ASSEMBLY**PICTORIAL 5-10****CONTINUE**

Connect the wires of the connector assembly as follows. Solder each wire into the top of the pin as you connect it.

(✓) Yellow to OUT.

(✓) Brown to GND.

(✓) Red to IN.

CIRCUIT BOARD CHECKOUT

Carefully inspect the foil side of the circuit board for the following most commonly made errors.

(✓) Unsoldered connections at leads that have foil.

(✓) "Cold" solder connections.

(✓) Solder bridges between foil patterns.

(✓) Protruding leads which could touch together.

Refer to the illustrations where the parts were installed as you make the following visual checks.

(✓) Transistors for proper **type** and **installation**.

(✓) Integrated circuits for the proper **type** and **installation**.

(✓) Electrolytic capacitors for the correct position of the positive (+) mark.

(✓) Diodes for the correct **type** and **position** of the banded end.

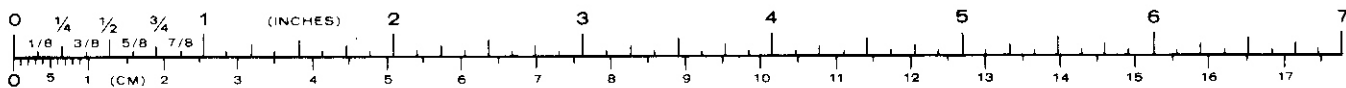

INSTALLATION

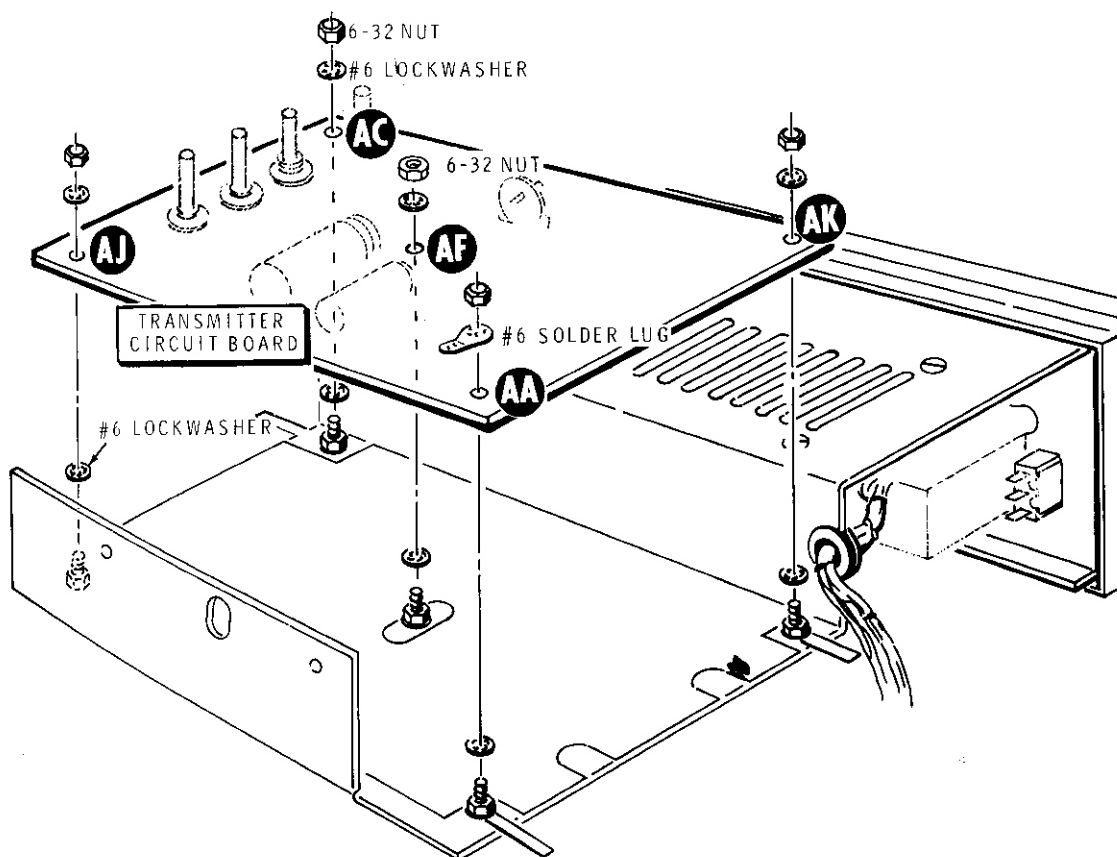

Detail 5-11A

Refer to Pictorial 5-11 (Illustration Booklet, Page 10) for the following steps.

- (✓) Refer to Detail 5-11A and mount the transmitter circuit board on the chassis. Use two #6 lockwashers and a 6-32 nut on each stud or screw at AC, AF, AJ, and AK. Use one #6 lockwasher, a #6 solder lug, and a 6-32 nut at AA. Position the solder lug as shown in the Pictorial. Make sure all of the harness wires are above the circuit board.

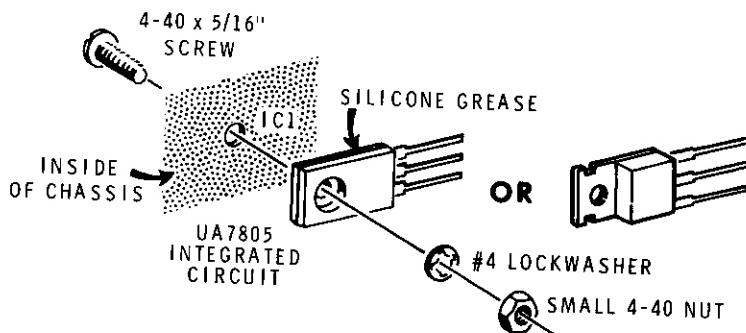

Detail 5-11B

- () Refer to the inset drawing on the Pictorial and cut open the silicone grease pod.
- () Place a small amount of silicone grease on the metal side of UA7805 integrated circuit (#442-54). Save the remaining silicone grease for use later.
- () IC1: Refer to Detail 5-11B and mount the UA7805 integrated circuit (#442-54) at IC1 with a 4-40 x 5/16" screw, a #4 lockwasher, and a small 4-40 nut. Be sure to mount the integrated circuit with the metal side toward the chassis. Then position the integrated circuit as shown.

Connect the wires coming from BO 4 of the wire harness to the transmitter circuit board as follows:

- () White-black wire to pin F.
- () White-brown wire to pin C.
- () White-red wire to pin D.
- () White-orange wire to pin E.
- () Green cable inner lead to pin A.
- () Green cable shield lead to pin B.

Connect the wires coming from BO 2 of the wire harness to the transmitter circuit board as follows:

- () White-black wire to pin J.
- () Red wire and .001 μ F capacitor to pin S.
- () Orange cable inner lead to pin M.
- () Orange cable shield lead to pin N.

Connect the wires coming from BO 1 of the wire harness to the transmitter circuit board as follows:

- () Any of the three white-orange wires to pin U.
- () Either remaining white-orange wire to pin T.
- () Remaining white-orange wire to pin W.
- () Red wire to pin P.
- () Either orange wire to pin R.
- () Other orange wire to pin V.
- () Red cable inner lead to pin K.
- () Red cable shield lead to pin L.
- () White-brown wire to pin H.
- () Plug the cable coming from the VCO assembly into jack J101.
- () Connect the IC connector to integrated circuit IC1 as shown in the inset drawing. Make sure the yellow wire in the connector is positioned as shown.
- () Locate the fuseholder assembly.
- () Open the fuseholder by twisting the two halves in opposite directions.
- () Cut the fuseholder assembly-wire 7" from each end. Remove and discard the longer fuse spring if two are supplied. Also discard the long red wire that you cut out.
- () Prepare the cut end of each fuseholder assembly wire.
- () Install a 5-ampere, 3 AG fuse and reassemble the fuseholder assembly.

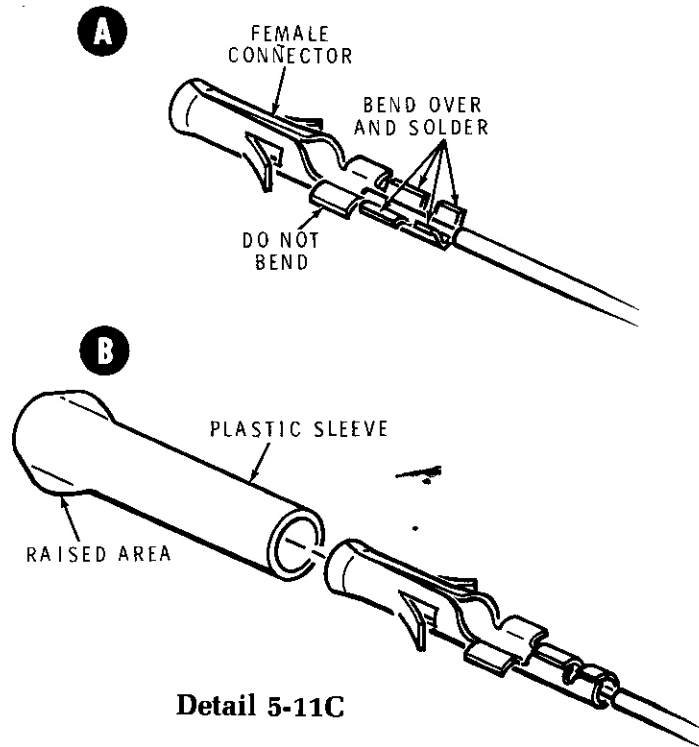

Detail 5-11C

- () Cut a 2" length of large sleeving. Then slide this length of sleeving over either fuseholder assembly wire and against the assembly.
- (✓) Refer to Detail 5-11C and solder a female connector to the end of the fuseholder wire that has the sleeving. Then push a plastic sleeve onto the connector. Be sure to position the raised areas on the sleeve as shown.
- (✓) Route the fuseholder assembly wire (that has the connector) through hole AY in the chassis and push it onto pin G on the transmitter circuit board.
- (✓) Prepare a 14" large black stranded wire.
- (✓) Refer to Detail 5-11D (Illustration Booklet, Page 10) and install a #6 solder lug on one end of this 14" wire. Use the outside hole in the solder lug, and solder the wire to the lug. Do not block the inner hole with solder. It will be used later.
- (✓) Route the other end of this wire through hole AY and through the large sleeving on the red fuseholder wire.
- (✓) Pull the black wire through the sleeving until the end is even with the free end of the other fuseholder assembly wire. Then slide the sleeving along the wires toward the chassis until the distance between the free ends of the two wires and the indicated end of the sleeving is 12". Be sure the solder lug on the black wire will reach hole DA.

NOTE: The large sleeving on the black wire and red fuseholder assembly wire is heat shrinkable, the same type as the medium sleeving you installed on PCB connectors earlier. In the next step, use the procedure you used with the medium sleeving on the PCB connectors.

- () Using a match or lighter, shrink the large sleeving around the black wire and red fuseholder assembly wire.

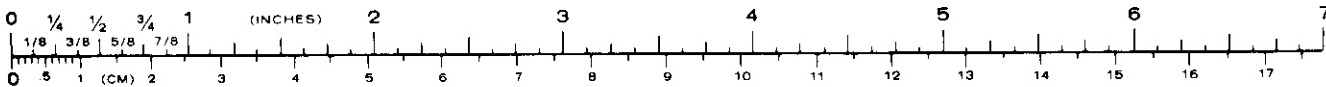

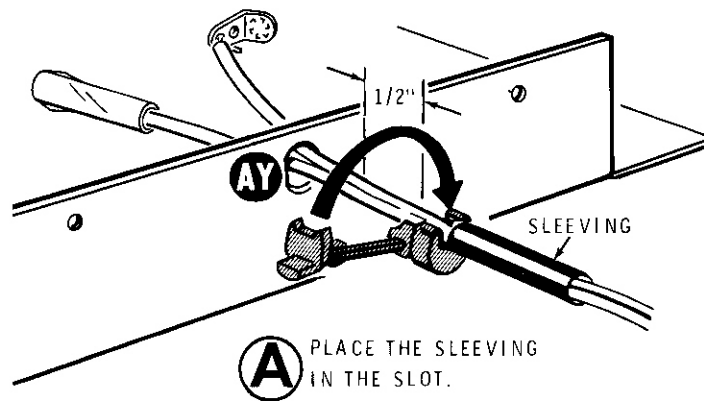

A PLACE THE SLEEVING
IN THE SLOT.

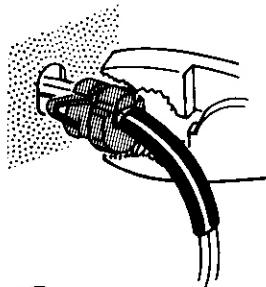

B SQUEEZE THE TWO
SEGMENTS TOGETHER.

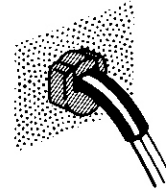

C INSERT THE REAR
HALF INTO THE HOLE.

Detail 5-11E

- (✓) Refer to Detail 5-11E and install a strain relief on the sleeved red and black wires at hole AY.

NOTE: The blue and white label shows the Model Number and Production Series Number of your kit. Refer to these numbers in any communications with the Heath Company about your kit. This assures you that you will receive the most complete and up-to-date information in return.

- (✓) Carefully peel the backing paper from the blue and white label. Then press the label onto the bottom of the chassis in the location shown.

Refer to Pictorial 5-12 for the following steps.

- (✓) Refer to Detail 5-12A and cut off the "ears" from the female connector housing.

- (✓) Install large male connectors on the free ends of the red fuseholder assembly wire and the large black stranded wire as shown in the Pictorial.

- (✓) Position the female connector housing as shown and push the male connector on the end of the red fuseholder wire into hole 3 of the housing until the connector locks in place.

- (✓) In the same way, push the male connector on the end of the large black wire into hole 1 of the housing.

NOTE: An extractor tool is furnished (see Detail 5-12B) so you can remove a pin from one of the connector housings, should it become necessary. To use the tool, push it very firmly over the end of the pin, as shown, until it compresses the expanded ears of the pin. When this occurs, the wire with its pin can be pulled from the other end of the housing.

Set the chassis aside until it is called for in a step.

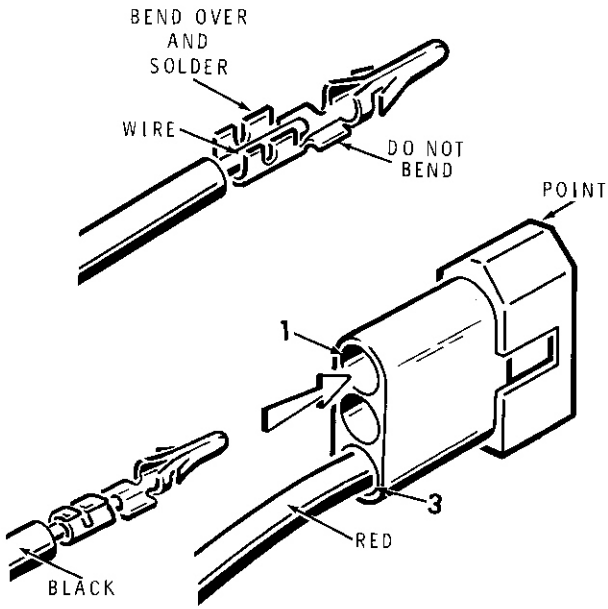

PICTORIAL 5-12

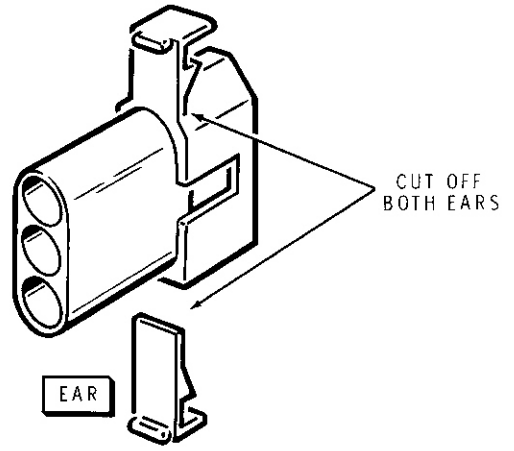

Detail 5-12A

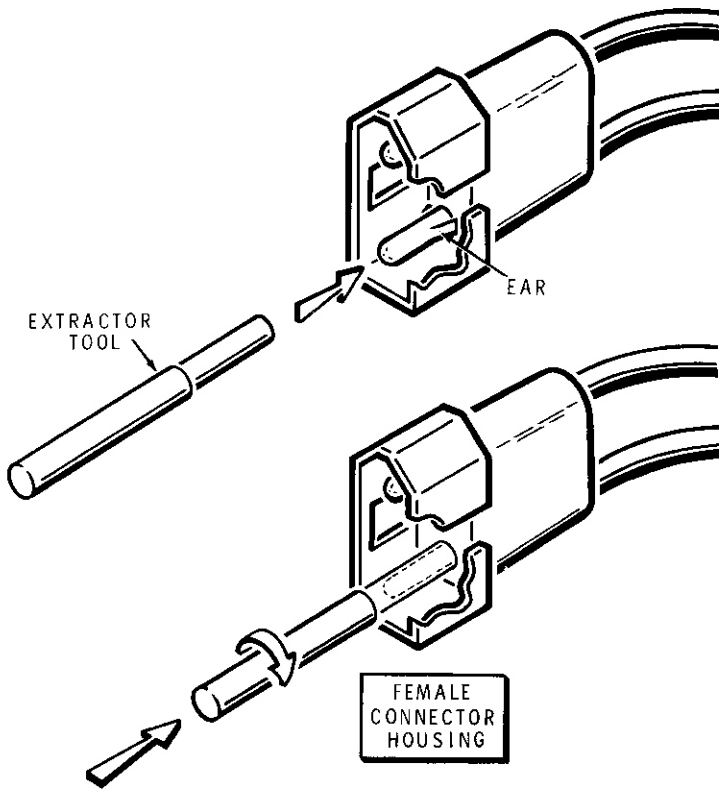

Detail 5-12B

POWER AMPLIFIER CIRCUIT BOARD

PARTS LIST

- () Refer to the Pack Index Sheet and locate Pack #5.
- () Unpack these parts and check each part against the following list. The key numbers correspond to the numbers on the "Power Amplifier Circuit Board Parts Pictorial" (Illustration Booklet, Page 11).

To order a replacement part, always include the PART NUMBER. Use the Parts Order Form furnished with this kit. If one is not available, see "Replacement Parts" inside the rear cover of this Manual. For price information, refer to the separate "Heath Parts Price List."

KEY No.	HEATH Part No.	QTY.	DESCRIPTION	CIRCUIT Comp. No.
---------	----------------	------	-------------	-------------------

RESISTORS, 1/4-Watt

A1	1-55-12	1	10 Ω , 5% (brown-black-black)	R301
A1	1-32-12	1	100 k Ω , 10% (brown-black-yellow)	R302

CAPACITORS

Ceramic

B1	21-169	2	6 pF	C311, C313
B1	21-3	1	10 pF	C312
B1	21-9	1	100 pF	C309
B1	21-11	1	150 pF	C306
B1	21-17	9	270 pF	C314, C316, C317, C318, C319, C321, C322, C323, C324
B1	21-154	1	.0051 μ F (5100 pF)	C304

KEY No.	HEATH Part No.	QTY.	DESCRIPTION	CIRCUIT Comp. No.
---------	----------------	------	-------------	-------------------

Capacitors (cont'd.)

Electrolytic

B2	25-220	1	10 μ F (tantalum)	C307
----	--------	---	-----------------------	------

Other

B3	28-3	1	.56 pF phenolic (green-blue-gray-silver)	C315
B4	31-54	1	4-40 pF trimmer	C302
B4	31-52	4	8-60 pF trimmer	C301, C303, C305, C308

DIODES — TRANSISTORS

C1	56-56	1	1N4149 diode	D301
C2	417-804	1	2N6080 or CTC B3-12 transistor	Q301
C2	417-803	1	2N6081 or CTC B12-12 transistor	Q302



KEY No.	HEATH Part No.	QTY.	DESCRIPTION	CIRCUIT Comp. No.
---------	----------------	------	-------------	-------------------

HARDWARE

Hardware packets are marked to show the size of the hardware they contain (HDW#4, HDW #6, etc.). You may have to open more than one packet in this pack to locate all of the hardware of any one (#6, for example) size.

#4 Hardware

D1	250-321	3	4-40 × 1/8" screw	
D2	250-163	3	4-40 × 5/16" self-tapping screw	

#6 Hardware

D3	250-56	8	6-32 × 1/4" screw	
D4	250-587	2	6-32 × 5/16" screw	
D5	250-298	4	6-32 × 3/4" hex head self-tapping screw	
D6	250-1157	10	6-32 × 1/4" stud	
D7	252-3	8	6-32 nut	
D8	254-1	15	#6 lockwasher	
D9	252-22	2	6-32 push-on nut	
D10	259-1	2	#6 solder lug	

#8 Hardware

D11	252-4	2	8-32 nut	
D12	252-181	2	8-32 shoulder nut	

CONNECTORS

E1	432-120	4	PCB connector	
E2	432-121	1	Small PCB pin	
E3	432-855	9	Female connector	
E4	432-184	1	9-pin receptacle	P301
E5	434-174	1	Dual phono socket	J301/J302
E6	438-4	2	Phono plug	
E7	438-46	1	Phono plug, 3/8" tip	

KEY No.	HEATH Part No.	QTY.	DESCRIPTION	CIRCUIT Comp. No.
---------	----------------	------	-------------	-------------------

MISCELLANEOUS

F1	45-38	2	.295 μH choke	RFC301, RFC302
F2	60-80	1	Slide switch	SW301
F3	69-72	1	Relay	K301
F4	475-10	16	1.07 μH ferrite bead	FB301—FB316
F5	204-2275	2	Angle bracket	
F6	431-40	1	Terminal strip	
F7	475-17	1	Toroidal core	
	490-168	1	1/4" × 5/16" end wrench	

PARTS FROM THE MAIN PACK

85-1661-2	1	Power amplifier circuit board
203-1466	1	Rear panel
205-1425-1	1	Panel plate

STEP-BY-STEP ASSEMBLY

START

NOTES:

- To avoid confusion when you mount and solder parts, each identification drawing indicates when the component (printed) side or foil side of the circuit board is shown.
- Most of the holes in this circuit board are "plated through" from one side to the other. Be careful. Do not allow solder to run into any hole other than the intended hole.

() Position the power amplifier circuit board component (printed) side up with the notch to the left.

() Bend the terminals of the five mica trimmer capacitors out as shown. Then cut through the center of each terminal lug to shorten the terminal.

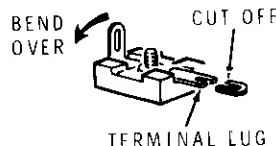

NOTES: In the following steps, as you install each trimmer capacitor, solder its terminals to the foil side of the circuit board as follows:

- Apply a very thin coating of solder to the foil areas where the terminals will be soldered (on the foil side of the circuit board).
- Solder each terminal to the foil. Hold the terminal down against the circuit board with the blade of a screwdriver until the solder cools.

CAUTION: In the Pictorial, the upper plate of each trimmer capacitor is shaded. It is very important that each upper plate be positioned as shown.

(✓) C302: 4-40 pF trimmer (#31-54).

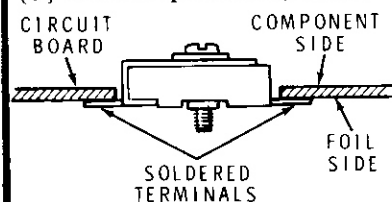

COMPONENT SIDE

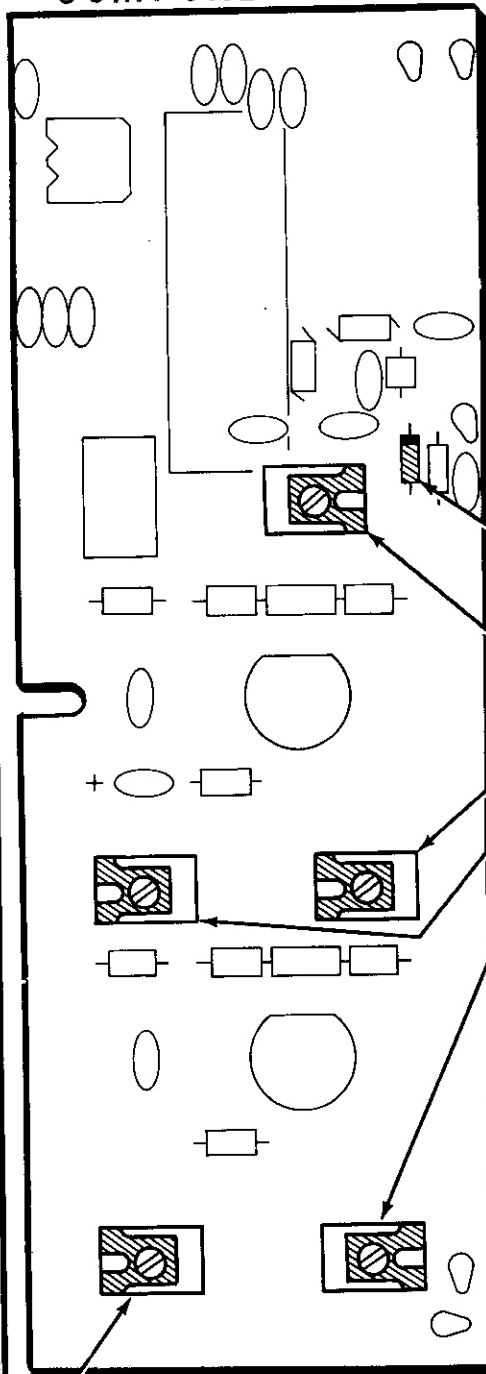

CONTINUE

NOTE: When you install a diode, position its banded end as shown in the Pictorial. A circuit will not operate properly if the diode is installed backward.

IMPORTANT: THE BANDED END OF DIODES CAN BE MARKED IN A NUMBER OF WAYS.

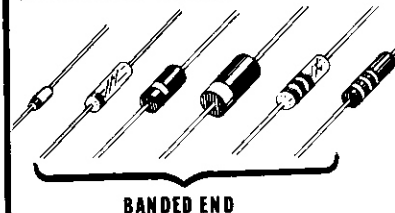

(✓) D301: 1N4149 diode (#56-56). Do not solder the leads yet.

(✓) C308: 8-60 pF trimmer (#31-52). Also solder the leads of diode D301 and cut off the excess lead lengths.

(✓) C303: 8-60 pF trimmer (#31-52).

(✓) C304: 8-60 pF trimmer (#31-52).

(✓) C301: 8-60 pF trimmer (#31-52).

(✓) Check again and make sure that each trimmer upper plate is positioned as shown.

PICTORIAL 6-1

START →

- (.) Cut two 5" lengths of magnet wire and scrape 3/8" of insulation from each wire end. Then apply a small amount of solder to the bare wire ends.

- (✓) Use the SHORTER end of the alignment tool and wind one 5" length of magnet wire into an 8-turn coil. Do not wind the solder-covered lead ends.

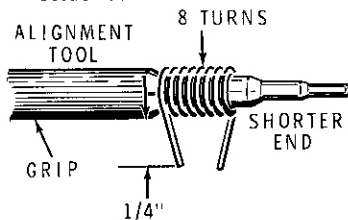

- (✓) Form the two coil leads so they point straight down as shown.



- (✓) L305: Mount the coil. Leave 1/16" clearance between the coil body and the circuit board. Solder the leads to the foil and cut off the excess lead lengths.

- (.) Wind another identical coil from the other 5" length of magnet wire.

- (✓) L304: Mount the coil. Leave 1/16" clearance between the coil body and the circuit board. Solder the leads to the foil and cut off the excess lead lengths.

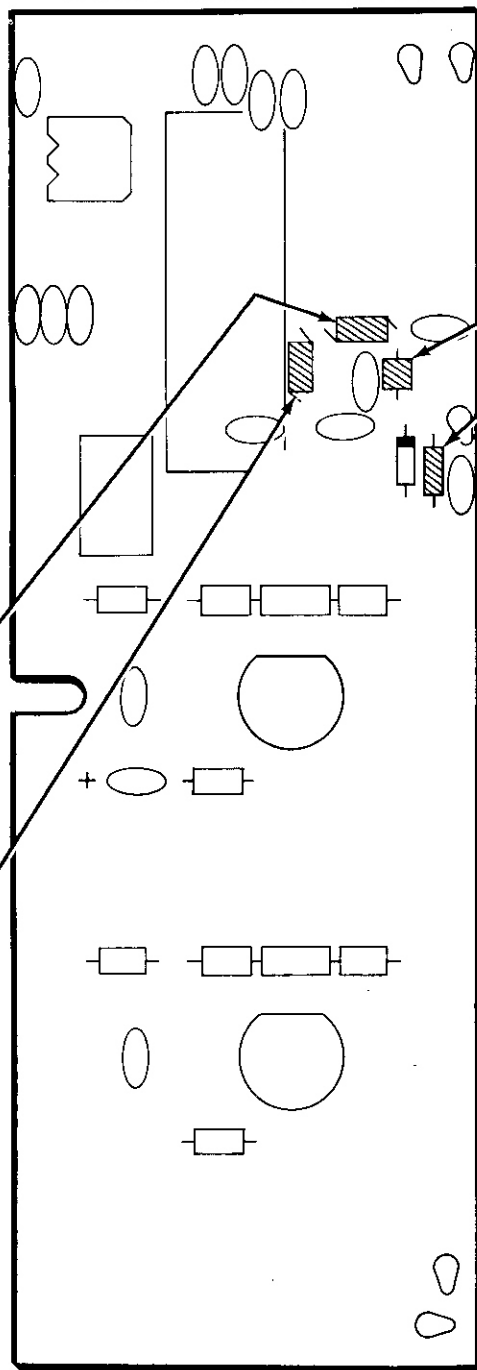
COMPONENT SIDE**CONTINUE** →

- (✓) C315: 56 pF (green-blue-gray-silver) phenolic capacitor.
- (✓) R302: 100 kΩ (brown-black-yellow).
- (✓) Turn the circuit board over, solder the leads to the foil, and cut off the excess lead lengths.

PICTORIAL 6-2



START →

NOTE: As you install ceramic capacitors, bend each one over toward the circuit board (or adjacent capacitor) as far as possible, because space will be limited when this circuit board is installed.

NOTE: When you install ceramic capacitors, do not push the insulated portions of the leads into the circuit board holes. This could make it difficult to solder the leads to the foil.

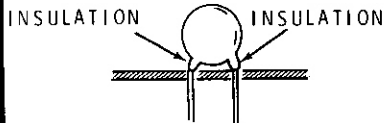

C321: 270 pF ceramic.

C316: 270 pF ceramic.

C323: 270 pF ceramic.

C319: 270 pF ceramic.

SAFETY WARNING: Avoid eye injury when you clip off excess lead lengths. We suggest you wear glasses, or at least clip the leads so the ends will not fly toward your eyes.

Turn the circuit board over, solder the leads to the foil and cut off the excess lead lengths.

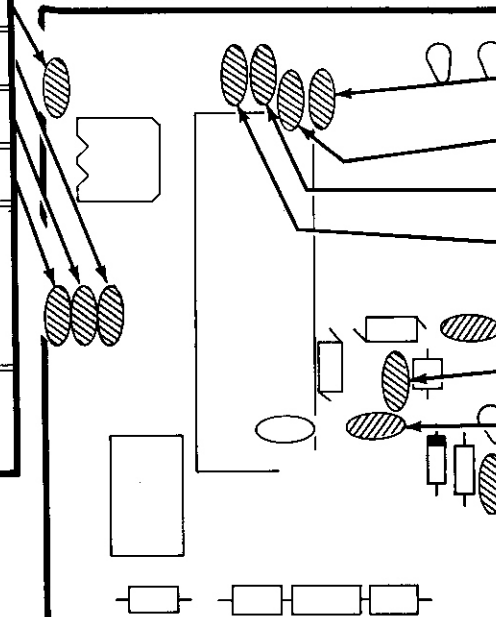
COMPONENT SIDE**CONTINUE** →

C317: 270 pF ceramic.

C324: 270 pF ceramic.

C318: 270 pF ceramic.

C322: 270 pF ceramic.

C313: 6 pF ceramic.

C312: 10 pF ceramic.

C311: 6 pF ceramic.

C314: 270 pF ceramic.

Turn the circuit board over, solder the leads to the foil, and cut off the excess lead lengths.

COMPONENT SIDE

START

NOTE: When you install a ferrite bead in this Pictorial, use a 1" length of bare wire. The bead may move on the wire after it is installed.

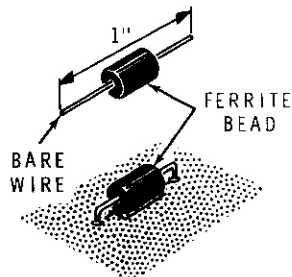

(✓) FB307: Ferrite bead.

(✓) C306: 150 pF ceramic.

(✓) C307: 10 μ F tantalum. Position the positive (+) or color dot marked lead of the capacitor toward the positive (+) marked hole.

(✓) FB304: Ferrite bead.

(✓) FB303: Ferrite bead.

(✓) C304: .0051 μ F (5100) ceramic.

(✓) R301: 10 Ω (brown-black-black).

(✓) Bend capacitors C306, C307, and C304 flat against the circuit board and in the direction shown.

(✓) Turn the circuit board over, solder the leads to the foil, and cut off the excess lead lengths.

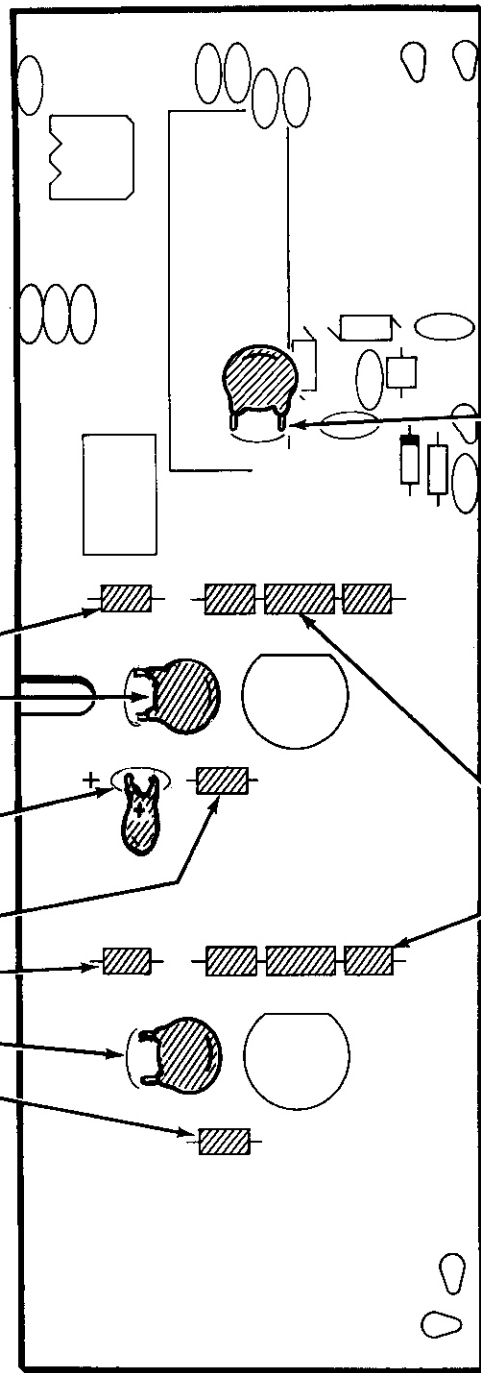

CONTINUE

(✓) C309: 100 pF ceramic. Bend the capacitor flat against the circuit board and in the direction shown.

(✓) Use RF chokes (#45-38) and ferrite beads to prepare two inductor assemblies as shown below.

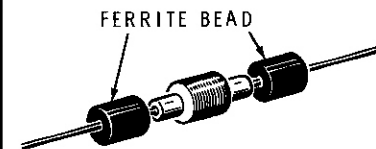

(✓) FB306/RFC302/FB305: Prepared inductor assembly.

(✓) FB302/RFC301/FB301: Prepared inductor assembly.

(✓) Turn the circuit board over. Then solder the leads to the foil and cut off the excess lead lengths.

PICTORIAL 6-4

START →

NOTE THE CHANGED POSITION OF THE CIRCUIT BOARD.

In the following numbered steps you will install the 9-pin receptacle housing on the foil side of the circuit board.

- (✓) 1. Locate the strip of nine female connectors (#432-855) and cut the connectors from the strip. Then cut off the two indicated tabs as shown below.

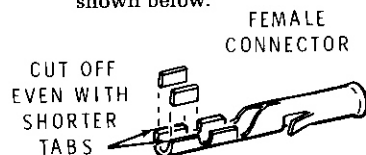

- (✓) 2. Install a 1" bare wire into a female connector as shown.

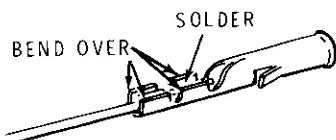

- (✓) 3. Push the connector into the indicated end of the 9-pin receptacle housing. Be sure the V-notched end of the housing is positioned as shown.

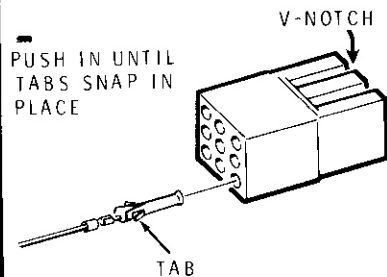

FOIL SIDE

V-NOTCHES

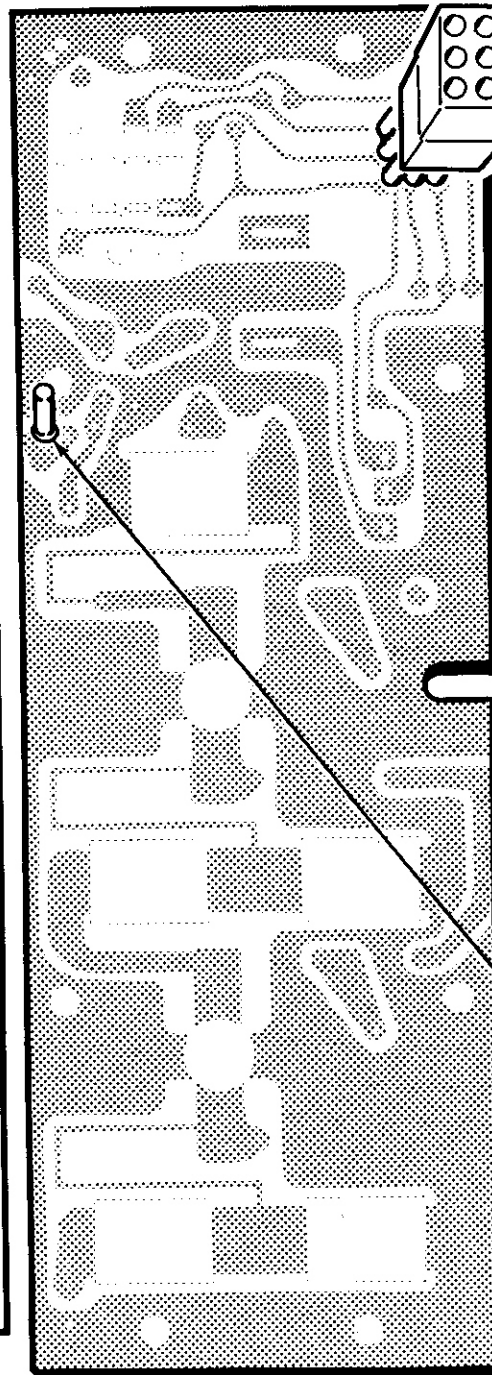
**CONTINUE** →

- (✓) 4. As before, install eight 1" bare wires into eight female connectors.
- (✓) 5. As before, push these connectors into the receptacle housing.
- () 6. FB308 through FB316: Place a 1.07 μ H ferrite bead on each of the nine leads extending from the receptacle housing. Be sure each bead is against the housing.
- (✓) 7. Insert the receptacle housing leads into their respective holes from the FOIL SIDE of the circuit board and install the receptacle housing and beads. Be sure the V-notched side is positioned as shown. Also be sure the receptacle housing and beads are pushed tightly against the circuit board. Then solder the leads to the foil and cut off the excess lead lengths.

- (✓) Connector pin in hole C. Mount and solder the pin on the foil side of the circuit board. Avoid getting solder on the top of the pin.

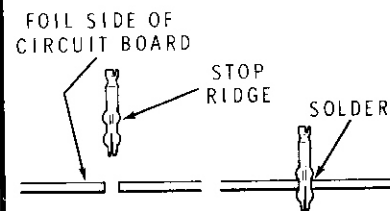

PICTORIAL 6-5



COMPONENT SIDE

START →

NOTE THE CHANGED POSITION OF THE CIRCUIT BOARD

() Relay lugs are numbered on the relay body and are also identified in the drawing to the right. Bend lug 3 back and forth with long-nose pliers until it breaks off where it enters the relay body.

(✓) Insert the relay into its mounting holes from the FOIL SIDE of the circuit board.

NOTE: When you solder relay lugs to the foil, in the following steps, be sure to apply solder all the way around the lug when possible.

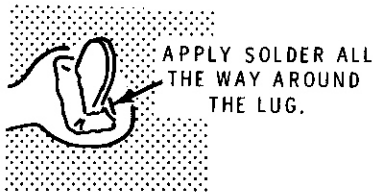

(✓) Make sure the relay body is tight against the circuit board. Then solder lugs 1 and 14 to the foil.

() Check to make sure the relay body is still tight against the board. If not, melt the soldered terminals and correct the position of the relay.

(✓) Solder the remaining relay lugs to the foil.

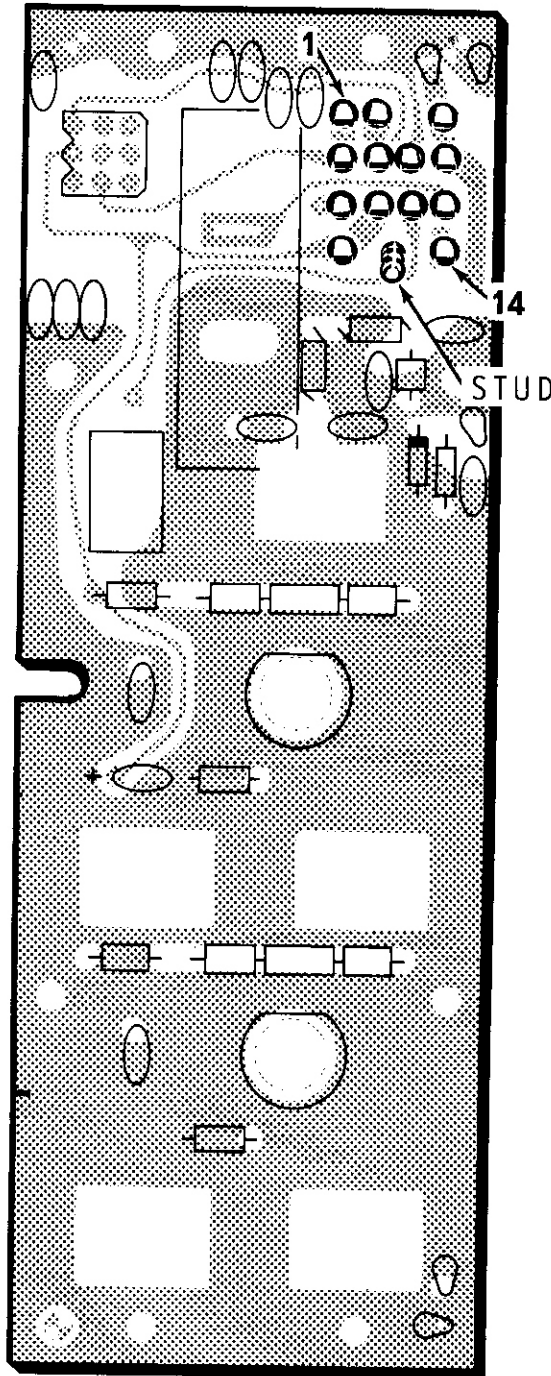

#3 BROKEN OFF

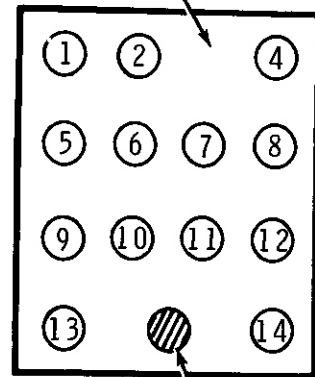

STUD

RELAY LUGS
(BOTTOM VIEW)

PICTORIAL 6-6

FOIL SIDE

START →

NOTE THE CHANGED POSITION OF THE CIRCUIT BOARD.

The power transistors used on this circuit board are similar in appearance, but one has a power rating four times the other. It is therefore very important that you properly identify them before you install them. Transistors with broad leads are illustrated, but transistors with narrow leads may be furnished. There is no difference in ratings. The collector lead is always identified by a clipped corner on the broad leads or by an angle cut across an entire narrow lead.

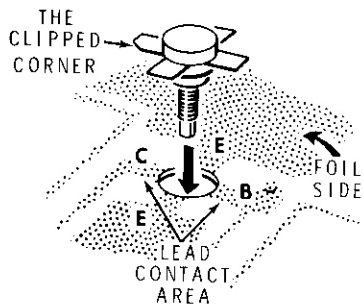

The transistor leads must be well soldered to the circuit board. A good electrical connection can be assured if you first apply a layer of solder to the lead contact areas of the circuit board foil. Once the transistors have been installed, they can be easily damaged by blows or severe jolts to the studs. Handle them with care.

Use your fingers to turn an 8-32 nut as far as possible onto the stud of each transistor. Do not use the 8-32 shoulder nuts.

CONTINUE ↘

Straighten bent or twisted transistor leads. Then proceed as follows to install a transistor:

From the foil side of the circuit board, push the transistor threaded stud into the mounting hole until the shoulder at the base of the stud enters the hole and the leads are flat against the foil side of the circuit board. Position the collector lead as shown, and solder each lead to the foil. Make sure the entire surface of the lead is soldered and is flat against the foil.

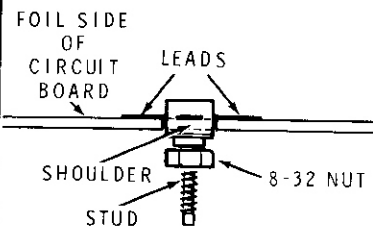

(-) Q302: 2N6081 or CTC B12-12 transistor (#417-803).

(✓) Q301: 2N6080 or CTC B3-12 transistor (#417-804).

(✓) At the B (base) lead of these transistors, be sure the wires coming from ferrite bead FB304 and resistor R301 on the other side of the circuit board remain properly soldered.

PICTORIAL 6-7

START ↘

NOTE THE CHANGED POSITION OF THE CIRCUIT BOARD.

- () Cut a 15" length of shielded cable. Prepare both ends as follows:

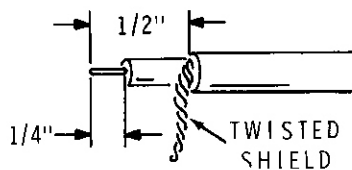

1. Remove 1/2" of the outer insulation.
2. Use a pointed object and comb out the braided shield wires.
3. Twist the shield wires into a small, tight point.
4. Remove 1/4" of insulation from the inner lead.
5. Melt a **small** amount of solder on the twisted shield and on the inner lead.

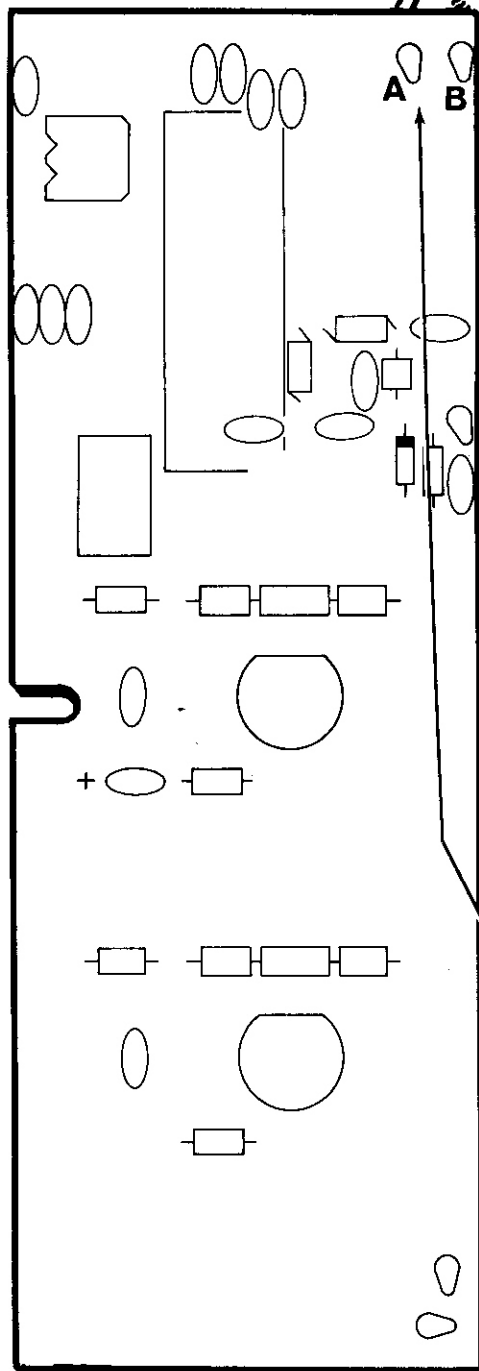
COMPONENT SIDE**CONTINUE** ↘

- () Install PCB connectors on one end of the cable as follow:
CRIMP CABLE ENDS
IN CONNECTOR.
THEN SOLDER

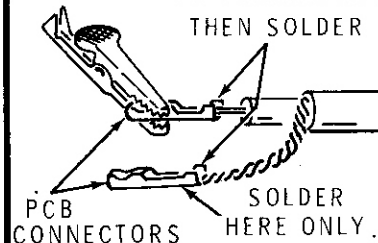

1. Place the end of the shield lead in a PCB connector. Then crimp the connector around the lead.
2. Clip the small alligator clip onto the connector, it will help keep the connector from twisting while soldering.
3. Carefully solder the lead to the connector. **CAUTION:** Do not allow the solder to flow into the open end of the connector.
4. Similarly install a PCB connector on the inner lead.
5. Save the alligator clip for use later.
6. Cut two 5/8" lengths of medium (heat shrinkable) sleeving.
7. Install the sleeving on the PCB connectors as you did before.

- () From the **FOIL SIDE** of the circuit board, insert the inner lead of the 15" length of shielded cable into hole A and the shield lead into hole B. Solder both connections on the **COMPONENT SIDE** of the circuit board.

- () Cut off any excess lead lengths at the shielded cable connections.

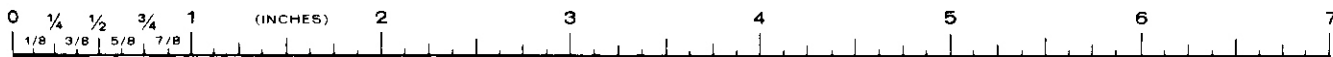
PICTORIAL 6-8

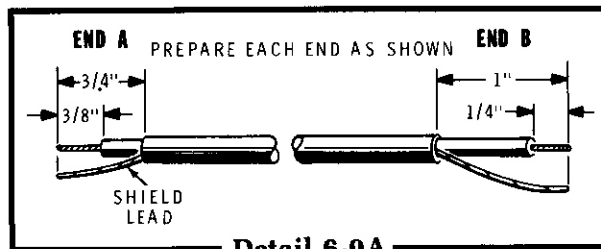

Detail 6-9A

COMPONENT SIDE

START

(✓) Cut a 4" length of shielded cable. Prepare the ends of this cable as shown in Detail 6-9A. Use the same procedure as before. NOTE: Be sure to remove 1" of outer insulation from one end as shown.

(✓) From the FOIL SIDE of the circuit board, insert the inner lead at end A of the 4" length of shielded cable into hole D, and insert the shield lead into hole E. Solder both leads to the FOIL SIDE of the circuit board. The other end of this cable will be connected later.

(✓) Cut off any excess lead lengths at the shielded cable connections.

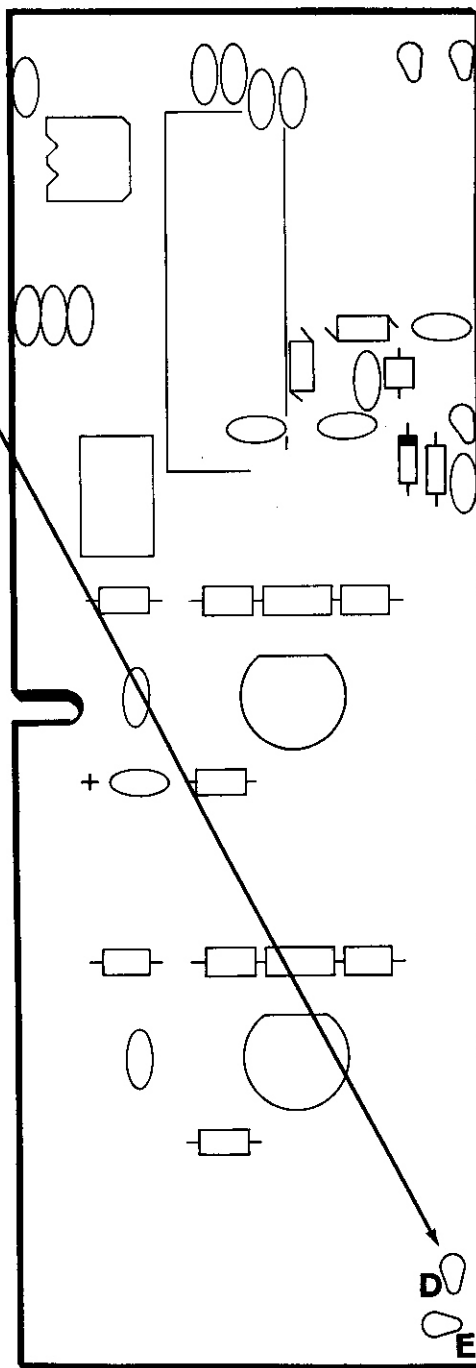

PICTORIAL 6-9

CONTINUE

CIRCUIT BOARD CHECKOUT

CAREFULLY INSPECT THE CIRCUIT BOARD FOR THE FOLLOWING CONDITIONS.

- () Unsoldered connections.
- () "Cold" solder connections.
- () Solder bridges between foil patterns.
- () Protruding leads. No wire leads should be longer than 1/8".
- () Transistors for the proper type and installation.
- () Tantalum capacitor for the correct position of the positive (+) lead.
- () Diode for the correct position of the banded end.

NOTE: Save the remaining length of shielded cable for use later.

Refer to Pictorial 6-10 (Illustration Booklet, Page 11) for the following steps.

(✓) Refer to Detail 6-10A and prepare a toroidal transformer as follows:

1. Cut two 4" lengths of magnet wire.
2. Insert one end of each wire through the toroidal core. Keep the two wires parallel and wind two complete turns around the core. NOTE: Be sure the two wires do not cross.
3. Look carefully at the windings through the core to make sure they are not crossed. Then locate the two wires that are closest together (labeled B and C on the Detail). Cut these wires to 1/2" and use a knife blade to scrape 1/4" of insulation from each wire end. Then twist these wires together.
4. Cut either remaining wire to 1/2" and the other to 3/4". Then scrape 1/4" of insulation from each wire end.

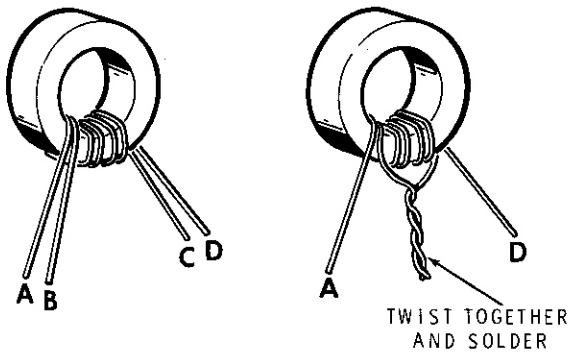

Detail 6-10A

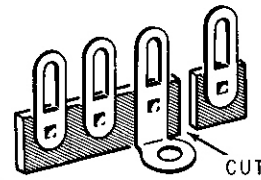

Detail 6-10B

- () Refer to Detail 6-10B and cut off and discard the indicated lug from the terminal strip.
- (✓) Refer to Detail 6-10C and mount the toroidal transformer to the terminal strip as follows:
1. Insert the twisted wires into the eyelet of lug 3 of the terminal strip (NS).
 2. Insert the shortest remaining lead into the eyelet of lug 2 of the terminal strip (NS).
 3. Insert the remaining lead into the eyelet of lug 1 of the terminal strip (NS).
 4. Position the transformer against the terminal strip as shown in the Pictorial and solder the wires to the eyelets.

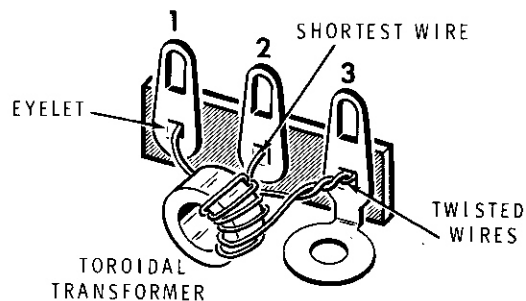

Detail 6-10C

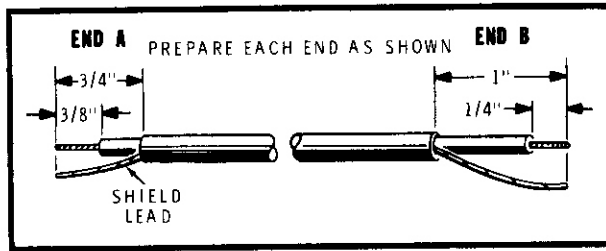

Detail 6-10D

- (.) Cut a 2-1/2" length of shielded cable. Prepare the ends of this cable as shown in Detail 6-10D. Use the same procedure as before. NOTE: Be sure to remove 1" of outer insulation from one end as shown.

- (✓) Refer to Detail 6-10E and install a phono plug on end B of the shielded cable prepared in the preceding step. Be sure to use plug #438-46. Also, be sure to put 3/4" of teflon sleeving onto the inner lead before you install the plug.

- (✓) Connect the free end of the shielded cable with the plug to the terminal strip as follows. Use 1/2" of small sleeving on the shield lead.

Inner lead to lug 1 (S-1).

Shield lead to lug 3 (NS).

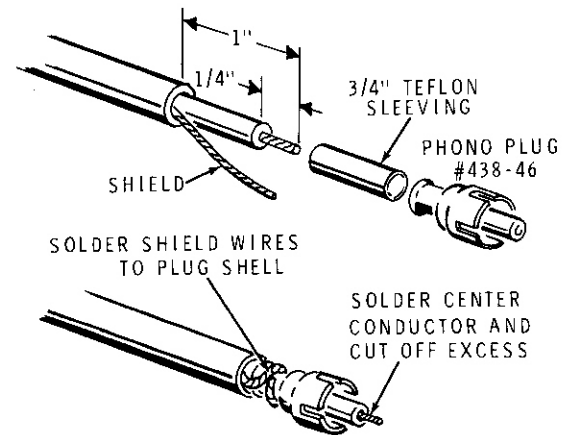

Detail 6-10E

- (✓) Position the terminal strip near the PA circuit board assembly. Then connect the free end of the shielded cable coming from the circuit board to the terminal strip as follows:

Inner lead to lug 2 (S-1).

Shield lead to lug 3 (S-2).

Set the circuit board aside temporarily.

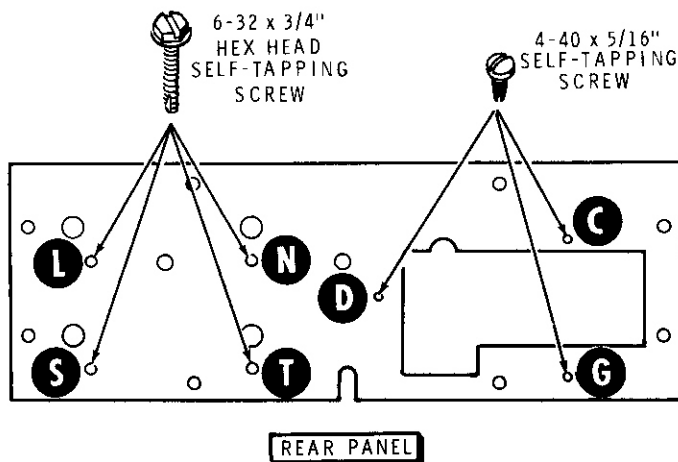

Detail 6-11A

Refer to Pictorial 6-11 (Illustration Booklet, Page 11) for the following steps.

- () Position the rear panel as shown in Detail 6-11A.

NOTE: You will tap seven holes in the rear panel in the following steps. To tap a hole, place the tip of the screw in the hole and apply downward pressure as you turn the screwdriver. Provide clearance for the screw to come through the other side of the panel. Be sure you keep the screw straight and turn it half way in. Then remove the screw and discard it. Use a new screw for each of the seven holes you will tap.

NOTE: Use four 6-32 × 3/4" hex head self-tapping screws in the following four steps, and then discard them.

- (✓) Tap hole L.
 (✓) Tap hole N.

- (✓) Tap hole S.
 (✓) Tap hole T.
 (✓) Remove the raised metal ridge around the tapped holes with a knife, file, or other tool.

NOTE: Use three 4-40 × 5/16" self-tapping screws in the next three steps and then discard them. Use caution that the screwdriver does not slip when you tap these holes.

- (✓) Tap hole C.
 (✓) Tap hole D.
 (✓) Tap hole G.
 (✓) As before, remove the metal ridge around each of the three holes.

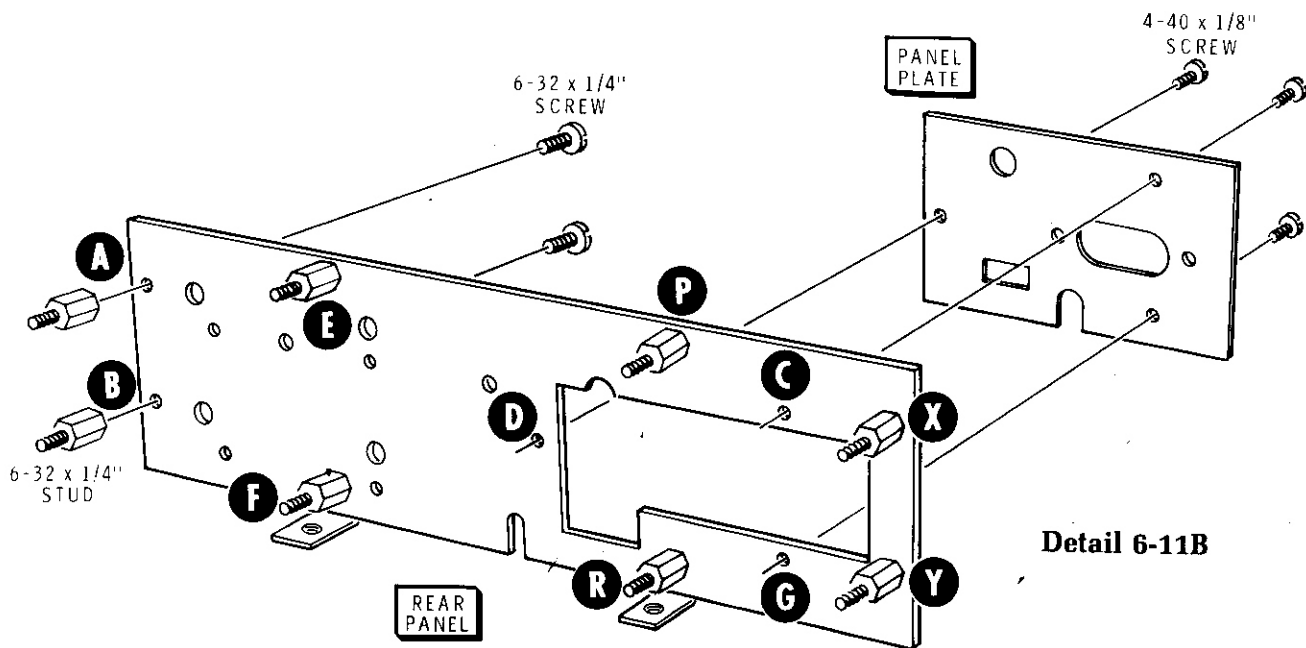

Refer to Detail 6-11B for the next two steps.

- () Position the rear panel and the panel plate as shown. Then loosely mount the panel plate to the rear panel with 4-40 × 1/8" screws in holes C, D, and G.
- () Loosely mount 6-32 × 1/4" studs with 6-32 × 1/4" screws in holes A, B, Y, X, P, and E. Be sure the studs are installed loosely on the side of the panel shown. Mount angle brackets at F and R as shown with 6-32 × 5/16" screws and 6-32 × 1/4" studs. Be sure the angle bracket at R is on the **outside** of the panel plate.
- () Tighten the 6-32 × 1/4" screws to secure the phono socket to the panel plate while you keep the plugs centered in cutout CC.
- () Solder a 1" bare wire to the ground lugs of the phono socket. Position the lead so it points straight out.

Refer to Detail 6-11C for the next five steps.

NOTE: When you perform the next step, use a small screwdriver to open the lips of the push-on nuts just enough to allow you to slide the nuts onto the phono socket.

- () Place two 6-32 push-on nuts on the dual phono socket. The curved lips of the nuts must be on the solder lug side of the socket. Align the holes in the push-on nuts with the holes in the socket.
- () Position the dual phono socket in the opening at CC in the panel plate. Then loosely mount the socket to the panel plate with 6-32 × 1/4" screws at CE and CA.
- () Push a phono plug into each phono socket.

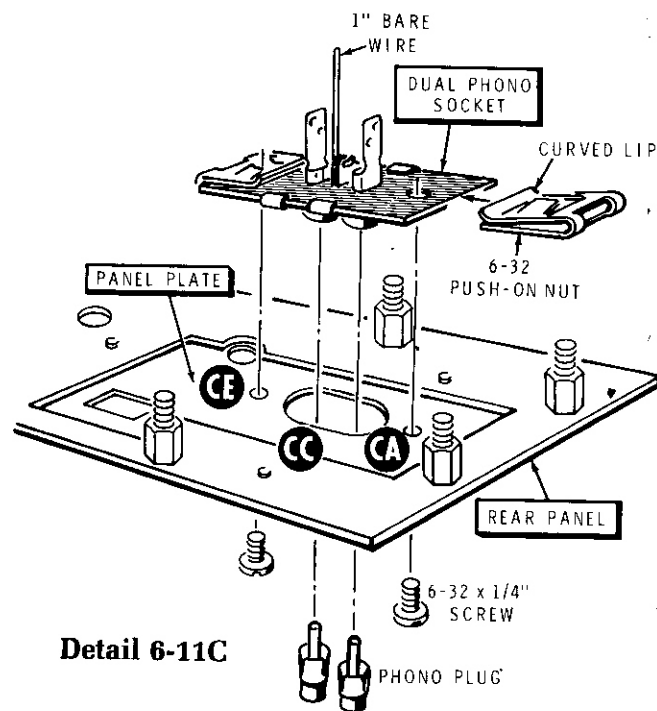

Detail 6-11C

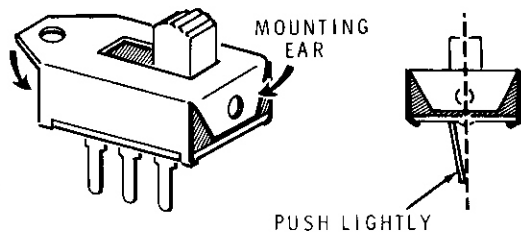

Detail 6-12A

Refer to Pictorial 6-12 (Illustration Booklet, Page 12) for the following steps.

- (✓) Position the rear panel as shown. Then place #6 lockwashers on the eight studs.
- (✓) Refer to Detail 6-12A and bend the mounting ears of the slide switch down against the ends of the switch body. If it has not already been done, bend the three switch lugs so their ends are in the center of the switch, as viewed from one end.
- (✓) SW301: From the component side of the circuit board, insert the three lugs of the slide switch into the three holes at SW301 in the circuit board. DO NOT solder the lugs. Make sure the switch is centered within the outline on the circuit board.
- (✓) Position the circuit board over the rear panel exactly as shown. Then carefully fit the two assemblies together as follows:
 1. Guide the two transistor studs into holes H and Q. (Do not put any strain on these studs.)
 2. Insert the slide switch into opening CG in the panel plate.
 3. Insert the two phono socket lugs and ground wire into their holes in the circuit board. You may have to bend the phono socket lugs to fulfill the requirements of step 1, above.
 4. Insert each stud into its corresponding circuit board hole.
- (✓) Carefully inspect the space between the circuit board and the rear panel for any parts which might interfere with a proper fit. For example, if a ceramic capacitor interferes, bend it over.
- (✓) Start 6-32 nuts onto each stud except those at R and F. Turn the nuts down against the circuit board, but do not tighten them.

- (✓) From the rear panel side of the assembly, tighten the 6-32 screws into the eight studs. Use the 1/4" end of the end wrench to hold the studs while you tighten the screws.
- (✓) Tighten all screws on the rear panel and panel plate if this has not already been done.
- (✓) Look into holes CF, K, M, U, and V to see that the trimmer adjusting screws are centered in the holes. If not, melt the solder at the trimmer capacitor terminals and move the capacitor as necessary to center the screws in the holes.
- (✓) Solder the two phono socket lugs and the phono socket ground wire to the foil side of the circuit board. Cut off the excess length of the ground wire.
- (✓) Make sure the slide switch body is against the back of the panel plate. Then solder the three switch lugs to the foil.
- (✓) Remove the two phono plugs and lay them aside for use later.
- (✓) Remove the 6-32 × 1/4" screws from holes CA and CE in the panel plate.
- (✓) Remove the 6-32 nuts from the studs on the circuit board side of the assembly and carefully remove the circuit board. Do not drop the lockwashers from the studs under the circuit board.
- (✓) Refer to Detail 6-12B and solder phono socket lug CJ to the foil at CK on the component side of the circuit board.

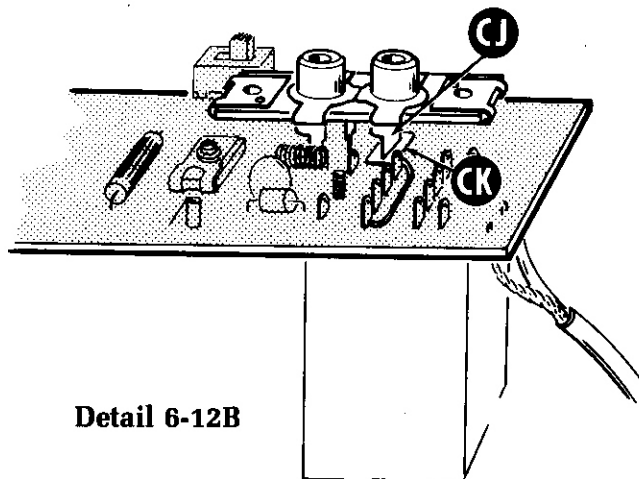

Detail 6-12B

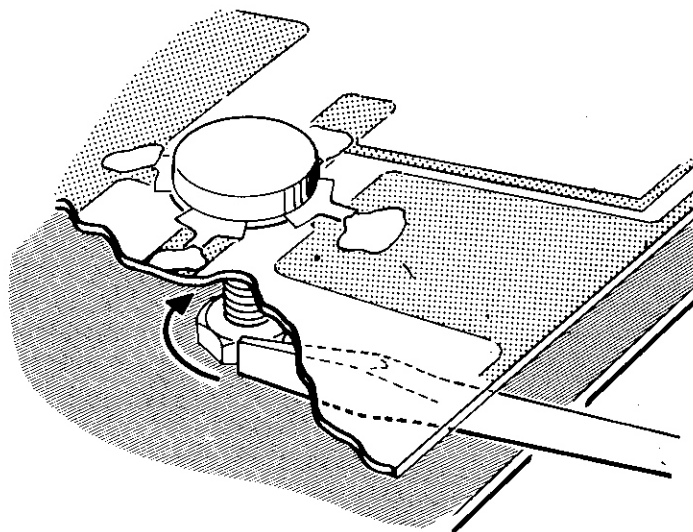

Detail 6-12C

NOTE: Silicone grease will be used to insure proper heat transfer from the power transistors to the rear panel. CAUTION: Do not get this grease in your eyes or on your clothing. Wash your hands after each application of silicone grease.

- (✓) Squeeze out some silicone grease from the container, about the size of a small pea, and spread it around holes H and Q on the stud side of the rear panel. Save the remaining silicone grease for use later.
- (✓) Again fit the circuit board and the rear panel together. Fasten the circuit board to the panel with #6 lockwashers and 6-32 nuts on all the studs **except** A, F, R, and Y. The nuts should be only finger tight.
- (✓) Refer to the inset drawing on the Pictorial and rebend the two #6 solder lugs to a 90° angle as shown.
- (✓) Fasten the circuit board to the rear panel at holes A and Y with #6 solder lugs and 6-32 nuts. Position the solder lugs as shown in the Pictorial. The nuts should be only finger tight.
- () Place a small amount of silicone grease on the shoulders of two 8-32 shoulder nuts and turn them onto the two transistor studs. The shoulders of the nuts should just enter the panel holes, but the under side of the nut should not touch the panel. **NOTE:** Save the remaining silicone grease for use later.

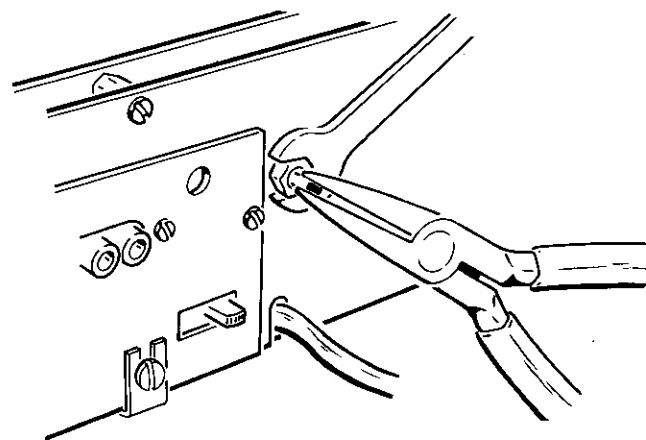

Detail 6-12D

- (✓) Install #6 lockwashers and 6-32 studs at F and R. Use the 1/4" × 5/16" end wrench to securely tighten the studs.
- (✓) Install the previously removed 6-32 × 1/4" screws in holes CA and CE of the panel plate.
- (✓) Refer to Detail 6-12C and, using a screwdriver blade to reach in between the rear panel and the circuit board, turn the nuts on the two transistor studs until they touch the back of the rear panel. **DO NOT** use the end wrench.
- (✓) Refer to Detail 6-12D and hold the end of a transistor stud with pliers while you use the end wrench to tighten the shoulder nut.
- (✓) Similarly, tighten the shoulder nut on the other transistor stud.
- (✓) Securely tighten all rear panel hardware. Pay particular attention to the six nuts on the foil side of the circuit board.
- (✓) Wipe off any excess silicone grease from around the transistor studs.
- (✓) Wash your hands.

INSTALLATION

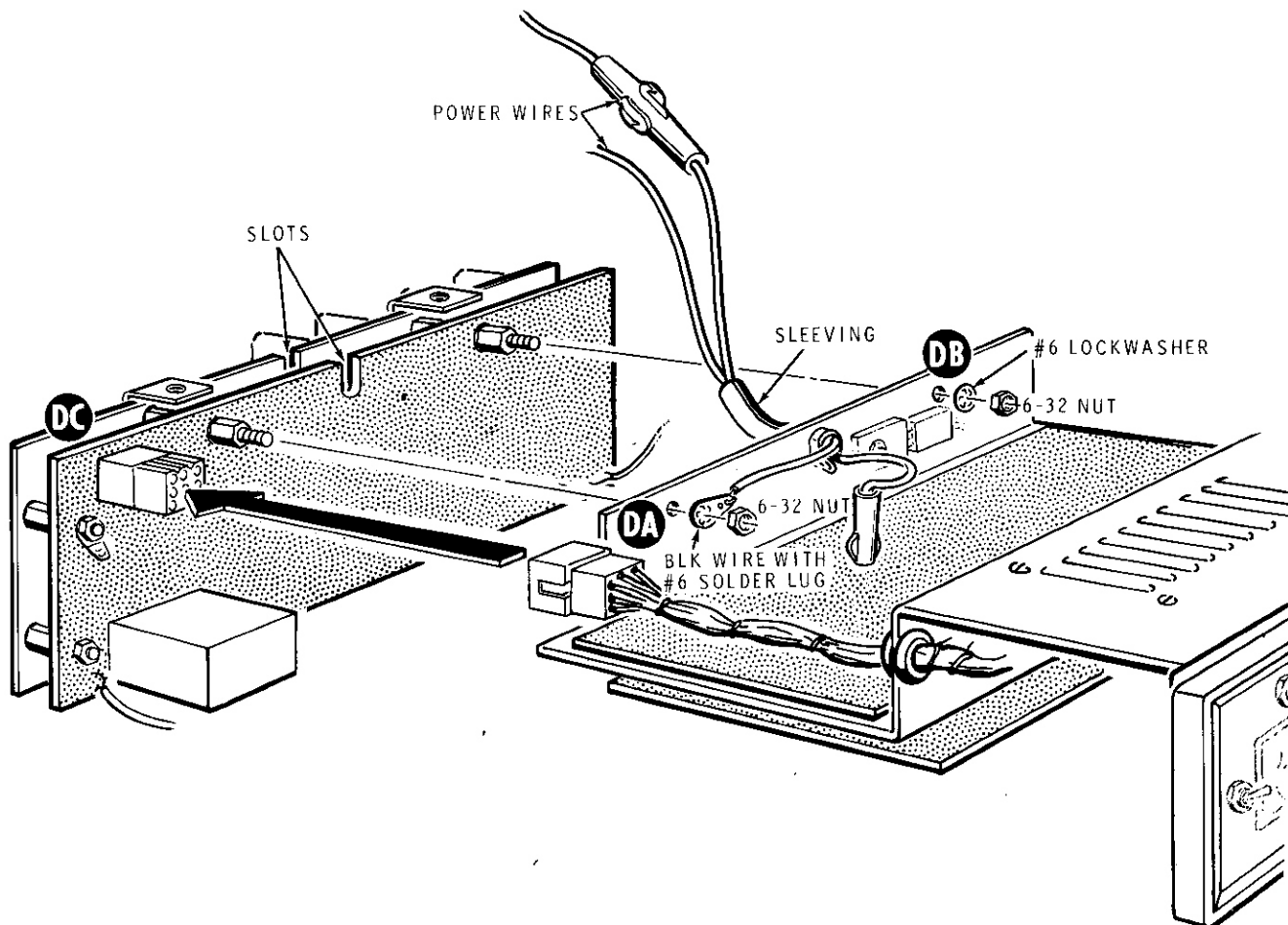

PICTORIAL 6-13

Refer to Pictorial 6-13 for the following steps.

- (1) Position the chassis upside down as shown. Then position the power amplifier circuit board assembly near the chassis as shown.
- (2) Carefully push the two studs on the power amplifier assembly into holes DA and DB in the chassis. Make sure the sleeving on the power wires is positioned in the slots in the assembly. CAUTION: Do not force the circuit board assembly into position or you may damage it.
- (3) Use a 6-32 nut to secure the #6 solder lug on the end of the large black wire to the stud at DA.
- (4) Mount the power amplifier assembly to the chassis at DB with a #6 lockwasher and a 6-32 nut.
- (5) Push the 9-pin housing onto the connector at DC.

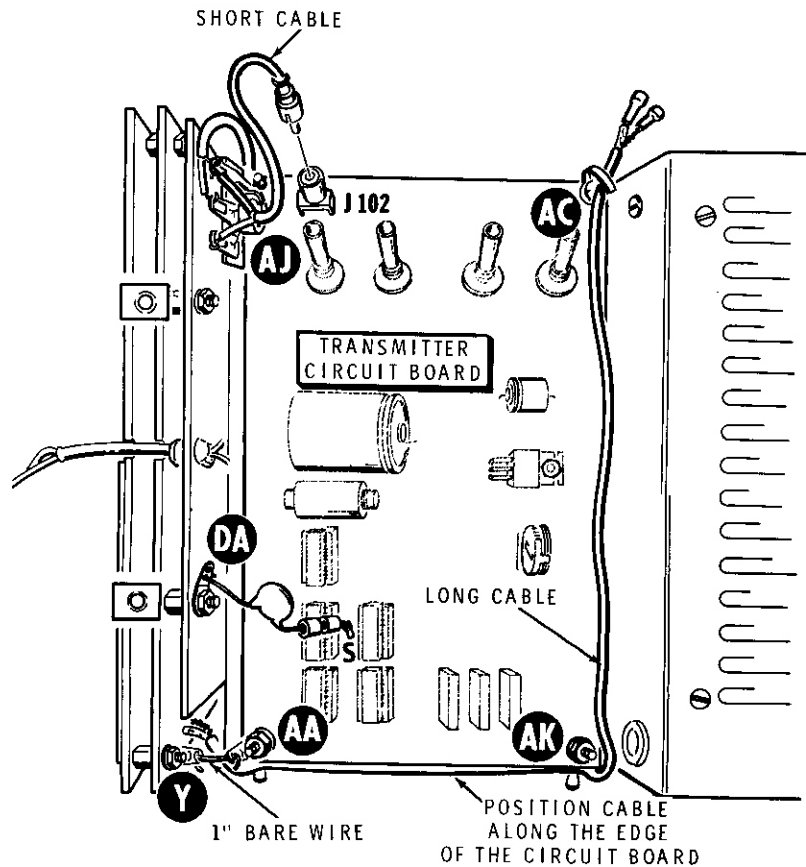

PICTORIAL 6-14

Refer to Pictorial 6-14 for the following steps:

(1) Remove the nut and lockwasher from the screw at AJ on the transmitter circuit board. Then use the hardware to mount the terminal strip coming from the power amplifier circuit board assembly at AJ as shown. Be sure to position the terminal strip as shown.

(2) Push the plug on the end of the short cable coming from the terminal strip into J102 on the transmitter circuit board.

(3) Route the long cable coming from the power amplifier circuit board as shown. Then bend the solder lugs at AA, AK, and AC upward to hold the cable in place. Position the cable along the edge of the circuit board between solder lugs AA and AK. The free end of this cable will be connected to the receiver circuit board later.

(4) Connect the free end of the capacitor coming from pin S on the transmitter circuit board to the inner hole of solder lug DA (S-1). NOTE: Be sure the black wire that was previously connected to this solder lug remains well soldered.

(5) Connect a 1" bare wire from solder lug Y (S-1) on the power amplifier circuit board to solder lug AA (S-1) on the transmitter circuit board.

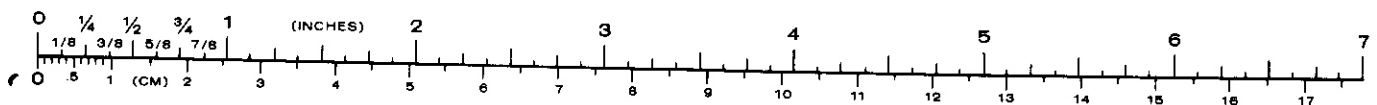

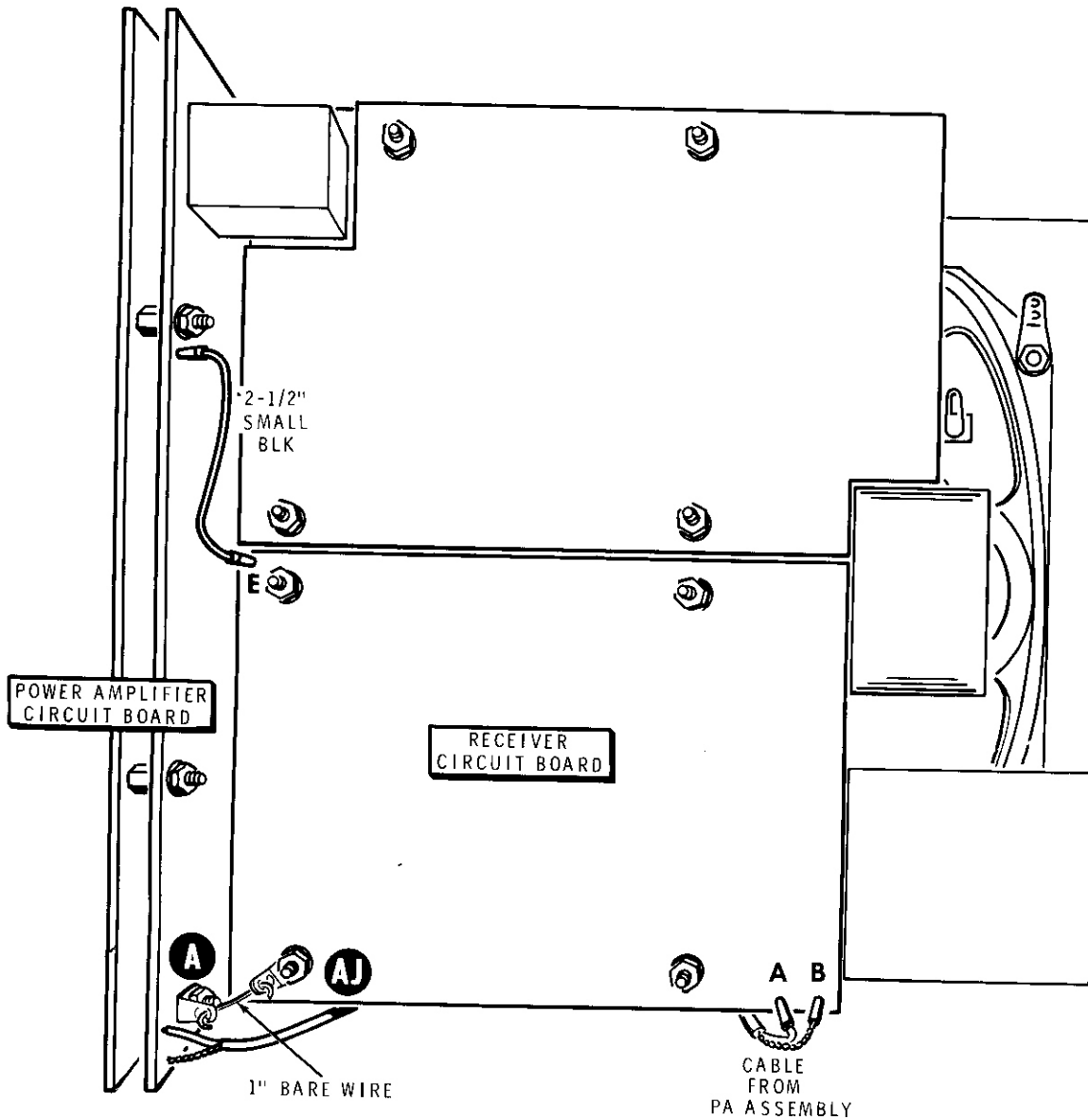

PICTORIAL 6-15

Refer to Pictorial 6-15 for the following steps:

- (✓) Position the chassis right-side-up as shown.
- (✓) Locate the free end of the cable coming from the power amplifier circuit board. Then connect the inner wire to pin A and the shield wire to pin B on the receiver circuit board.
- (✓) Connect a 1" bare wire from solder lug A (S-1) on the power amplifier circuit board to solder lug AJ (S-1) on the receiver circuit board.

- (✓) Prepare a 2-1/2" small black stranded wire.
- (✓) Install PCB connectors on each end of this wire.
- (✓) Cut two 5/8" lengths of medium (heat shrinkable) sleeving.
- (✓) Install a 5/8" length of sleeving on each PCB connector on the 2-1/2" wire.
- (✓) Connect the 2-1/2" wire from the indicated PCB pin on the power amplifier circuit board to receiver circuit board PCB pin E.

MICROPHONE INSTALLATION

NOTE: If you purchased the kit with the standard microphone, proceed directly to "Microphone Wiring." If you purchased the kit with the Micoder, locate that kit and assemble it up to "Level Adjustment."

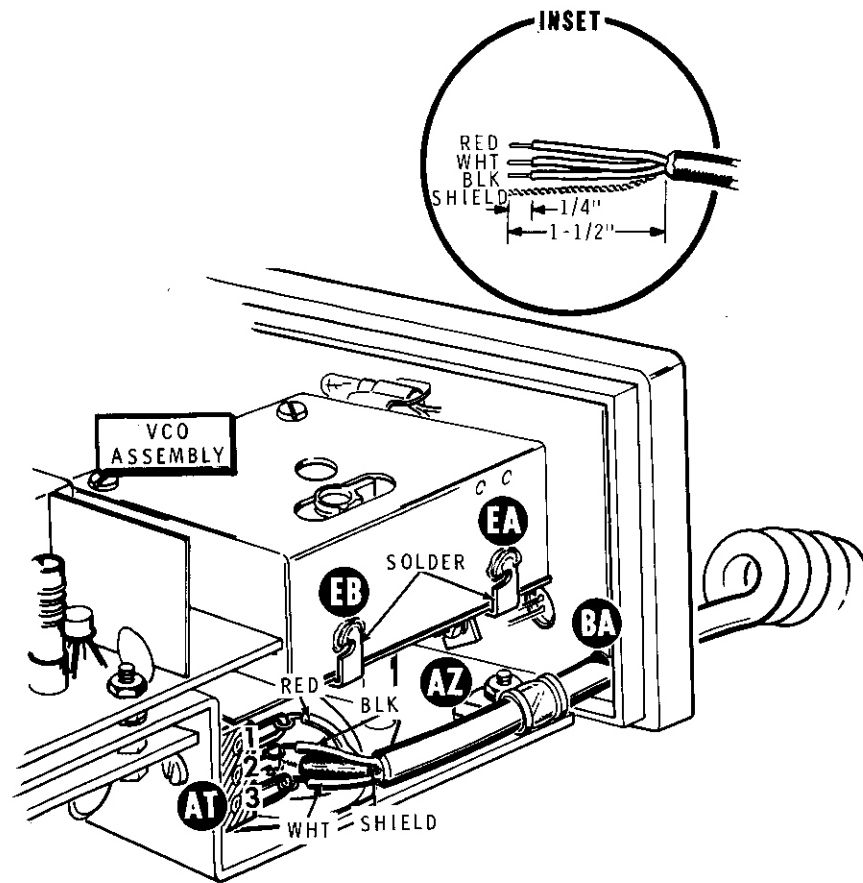

PICTORIAL 7-1

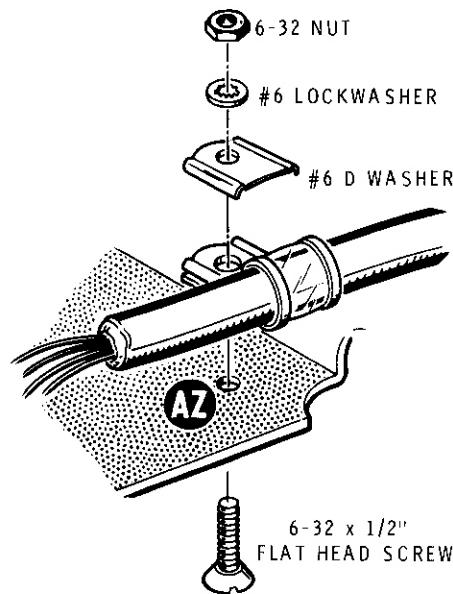

Detail 7-1A

MICROPHONE WIRING

Refer to Pictorial 7-1 for the following steps.

- (1) Position the chassis right side up.
- (2) Locate the microphone and prepare the wires at the free end of the microphone cord as shown in the inset drawing. Melt a small amount of solder on each wire to hold the fine strands together.
- (3) Route the prepared end of the microphone cord through hole BA in the front panel.

Connect the wires of the cord to terminal strip AT as follows:

- (1) White wire to lug 3 (S-2).
- (2) Black wire to lug 2 (NS).
- (3) Shield wire to lug 2 (S-4). Use 1-1/4" of small sleeving on this lead.
- (4) Red wire to lug 1 (S-3).

- (5) Refer to Detail 7-1A and install a cable clamp around the microphone cord at AZ. Then secure the cord to the bottom of the chassis with a 6-32 x 1/2" flat head screw, a #6 D washer, a #6 lockwasher, and a 6-32 nut. Tighten the hardware securely.
- (6) Bend the solder lugs at EA and EB, on the VCO assembly, up against the top VCO shield as shown. Hold the top shield tight against the bottom shield; then solder the lugs to the shield.

This completes the "Step-by-Step Assembly" of your Synthesized 2-Meter FM Transceiver. Before you proceed to "Initial Tests," look it over carefully to be sure:

1. That all the hardware is tightened.
2. There are no unsoldered connections.
3. There are no cut off wire ends or solder splashes lodged in the wiring.
4. There are no protruding wire ends that could short out to adjacent lugs.

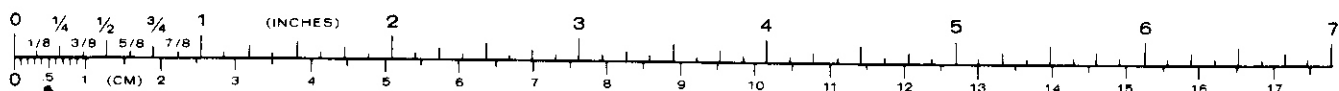

INITIAL TESTS

POWER SOURCES

Your Transceiver must have power applied to it so you can perform the steps in the "Initial Tests" and "Alignment" sections of this Manual. If you have the Heathkit Model HWA-2036-3 Power Supply, or some other power supply capable of supplying 13.8 volts DC at 2.6 amperes, perform the steps under "Fixed Station." If you plan to use this transceiver as a mobile station only, proceed to "Mobile Station."

Fixed Station

NOTE: This Transceiver should be powered at a fixed station by the Heathkit Model HWA-2036-3 Power Supply or equivalent. If you use the HWA-202-1 Power Supply, you may have to decrease its output voltage to 12.5 volts. This will somewhat decrease the Transceiver's power output, but will still keep the Power Supply ripple within limits by decreasing the current drain.

Install a connector on the output wires of your power supply. Refer to the first four steps under "Fixed Station Installation" on Page 128. Then return to this section of the Manual.

Mobile Station

If you will use this Transceiver in a mobile installation only, locate the large red and large black wires furnished with this kit. Refer to the first four steps under "Fixed Station Installation" on Page 128 and install a connector on one end of each wire. Temporarily connect the free end of the red wire to the positive (+) terminal and the free end of the black wire to the negative (-) terminal of your battery. Then return to this section of the Manual.

Refer to Pictorials 8-1 and 8-2 (in the Illustration Booklet) for the location of the controls and switches called out in the following steps.

TESTS

(1) Preset the controls and switches as follows:

SQUELCH	Fully Counterclockwise
SPKR	INT
MODE	SIM
TONE	OFF
VOLUME	Fully counterclockwise until it clicks.

The position of the other controls and switches is not important at this time.

Adjust your power supply for 13.8 volts. Then plug the power supply connector into the Transceiver's power connector.

NOTE: DO NOT depress the microphone button until you are directed to do so in a step.

(2) Turn your power supply on if you are using one.

NOTE: If your Transceiver does not respond correctly in the next step (in all three ways), turn the Transceiver off and proceed to the "Initial Tests Troubleshooting Chart."

(3) Turn the VOLUME control clockwise about 1/2 turn. The meter lamp should light, the Synth Lock Lamp should light (either briefly or continuously), the relay should click, and you should hear random noise.

Use a voltmeter to check the voltages at the following points. If the voltages are outside the limits given, turn the Transceiver off and proceed to the "Initial Test Troubleshooting Chart."

(✓) 11 volts (10.7 to 12) at pin U on the transmitter circuit board.

(✓) 5 volts (4.75 to 5.25) at pin S on the transmitter circuit board.

(✓) Turn the Transceiver off.

NOTE: Refer to Pictorials 9-10 through 9-12 in the Illustration Booklet for the pins called out in the following steps.

This completes the "Initial Tests." Proceed to "Alignment."

INITIAL TEST TROUBLESHOOTING CHART

CONDITION	TROUBLESHOOTING PROCEDURE
A. Completely dead.	1. Check for open fuse. Check power supply polarity and D102. 2. Check for proper voltage from power source. 3. Check POWER switch SW1.
B. Synth Lock lamp stays out.	<pre> graph TD START[START] --> J[5 volts at synthesizer circuit board at pin J.] J -- NO --> S[5 volts at transmitter circuit board pin S.] S -- NO --> E[Proceed to condition E.] S -- YES --> W[Check wiring.] W --> Q[Q407, Q408, LED1.] J --> G[Use a short wire to ground pin 4 of IC405. Synth Lock lamp comes on.] G -- NO --> Q G -- YES --> Q4[Q405, D401, IC405.] </pre>
C. No noise from speaker with SQUELCH control fully counterclockwise. (SPKR switch at INT).	<pre> graph TD START[START] --> G[13.8 volts at receiver circuit board pin G.] G -- NO --> R1[1. Relay contacts. 2. Socket S301 wiring.] G -- YES --> F[11 volts at receiver circuit board pin F.] F -- NO --> R2[1. Relay contacts. 2. Socket S301 wiring.] R2 -- NO --> D[Proceed to condition D.] F -- YES --> ID[Refer to "In Case of Difficulty."] </pre>
D. 11 volts not present at transmitter circuit board pin U.	<pre> graph TD START[START] --> Z[Voltage at cathode of ZD101 between 11.4 and 12.6 volts.] Z -- NO --> ZD[ZD101.] Z -- YES --> Q1[Q104.] </pre>
E. 5 volts not present at transmitter circuit board pin S.	1. IC1 faulty. 2. IC1 socket incorrectly wired, installed, or intermittent. 3. Excessive current drain on 5-volt line. (Disconnect red wire from transmitter circuit board pin S. If 5 volts is now present, look for problem on synthesizer circuit board. If not, look for problem on transmitter circuit board.)

ALIGNMENT

You can completely align your Transceiver, with the exception of the tones, with a VTVM or a high input impedance VOM (at least 20,000 ohm/volt) and a receiver capable of receiving WWV on 15, 20, or 25 MHz. A frequency counter, however, would be helpful to check the transmitter frequencies and to set the tones. Alignment with a frequency counter will insure optimum performance.

IMPORTANT: DO NOT align this Transceiver with the antenna connected. This could cause a transmitter power loss and, more important, harmonic radiation which could interfere with television reception and other communication devices. As emphasized in the "Installation" section, all adjustments for antenna matching must be made to the antenna and transmission line **and not to the Transceiver.**

COIL CORES

During the alignment procedure, you will use the coil alignment tool to adjust a number of coil cores. You will find that these cores are usually within two turns of the correct position.

1. If a coil core will turn but offers resistance, put a very small amount of petroleum jelly on the inside of the coil form next to the core and then back the core out. Its threads will pick up the lubrication and the core will turn more easily.
2. If you wedge a core down against the circuit board and cannot back it out, you will have to unsolder the coil form pins so the coil form can move away from the board slightly to relieve the pressure.

ALIGNMENT PREPARATION

Refer to Pictorial 9-1 for the following steps:

- (✓) Prepare an 8" small red stranded wire.
- (✓) Solder a PCB connector (#432-120) to one end of the prepared wire.
- (✓) Solder a small PCB pin to the other end of the prepared wire.

Refer to Pictorial 9-2 for the following steps:

- (✓) Prepare an 8" small black stranded wire.
- (✓) Solder a PCB connector (#432-120) to one end of the prepared wire.
- (✓) Solder an alligator clip to the other end of the prepared wire.

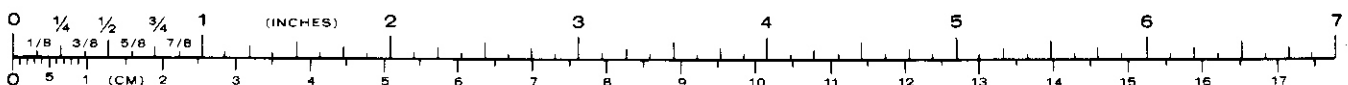

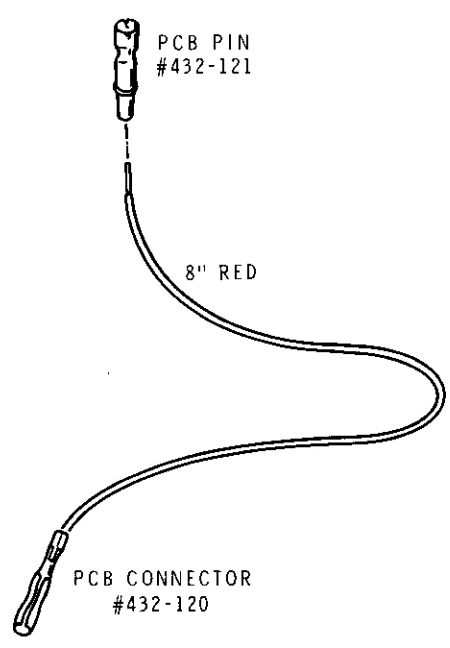

PICTORIAL 9-1

Refer to Pictorial 9-3 for the following steps:

- () Prepare a 14" shielded cable as shown.
- () Solder a PCB connector (#432-120) to each lead at each end of the cable.

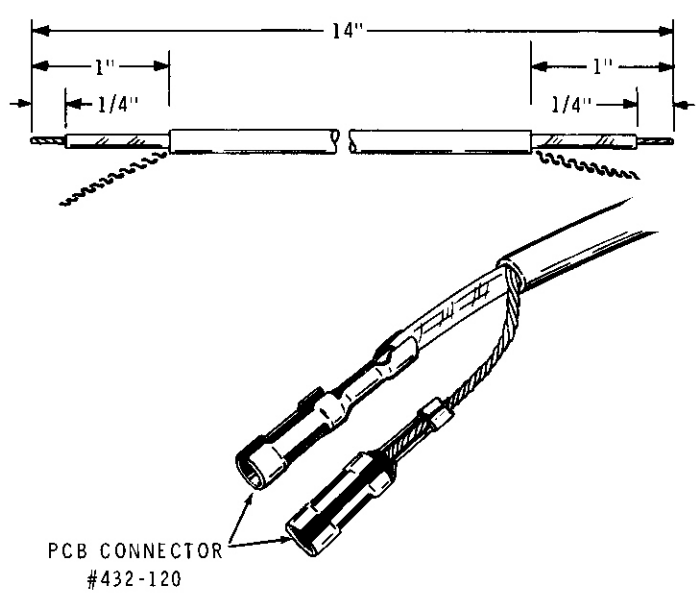

PICTORIAL 9-3

Refer to Pictorial 9-4 for the following steps.:

- (✓) Locate a 51 ohm, 1/2-watt (green-brown-black) resistor. Then cut each lead to 1/2".
- (✓) Install the prepared 51 ohm resistor in a phono plug. Be sure to use the #438-46 plug. Then cut off the excess lead lengths. This assembly forms an "alignment load."

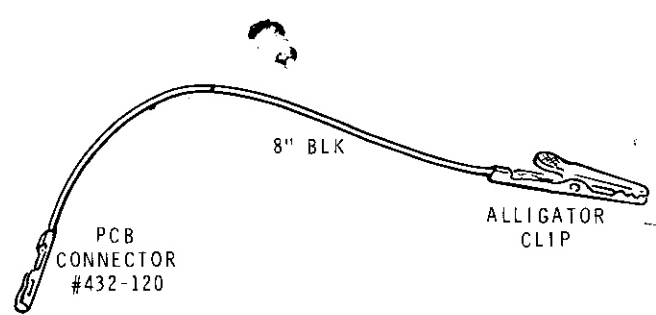

PICTORIAL 9-2

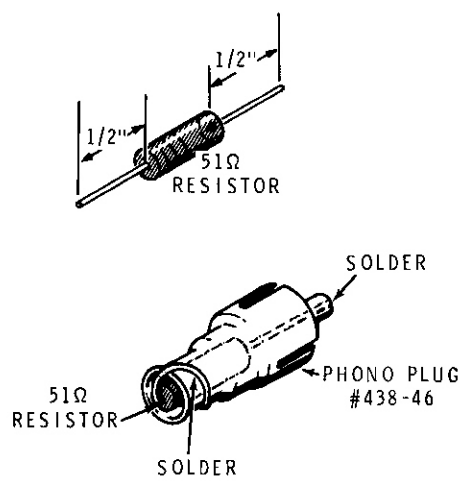

PICTORIAL 9-4

Refer to Pictorial 9-5 and assemble a 50 ohm dummy load as follows:

- (✓) Cut one lead of a 100 ohm, 2-watt (brown-black-brown) resistor to 1/4". Then form the lead into a small hook.
- (✓) Bend down the lead of another 100 ohm resistor, hook the lead of the first resistor around this lead, and solder the leads together as shown.
- (✓) Cut a 1/4" length of small black sleeving. Then place it into the back (large opening) of a phono plug.
- (✓) Push the lead of the resistor as far as possible through the sleeving and out the phono plug tip. Solder the resistor lead to the phono plug tip and cut off the excess lead.
- (✓) Form the leads of the two resistors so they touch the phono plug tip as shown. Then solder each lead to the housing.
- (✓) If you have an ohmmeter, measure the resistance from the phono plug tip to its outer shell to make sure there is no short circuit. The correct resistance is about 50 ohms.

Refer to Pictorial 9-6 and assemble an RF probe as follows:

- (✓) Prepare a 4-lug terminal strip as shown in Detail 9-6A.
- (✓) Position the 4-lug terminal strip as shown in Detail 9-6B. Then push a small PCB pin into the eyelets of lugs 1, 3, and 4. Solder the pins to the eyelets.
- (✓) Connect the lead at the banded end of a 1N191 diode (#56-26, brown-white-brown) to lug 2 (NS). Connect the other diode lead to lug 3 (NS).

NOTE: In the following step, bend over the capacitor lead connected to lug 1 as shown. DO NOT cut this lead off except as you are directed in the step.

- (✓) Connect a .001 μ F ceramic capacitor between lugs 1 (S-1) and 2 (NS). Cut the lead extending from lug 1 to 3/4".
- (✓) Connect another .001 μ F ceramic capacitor between lugs 3 (S-2) and 4 (NS).

- (✓) Connect a 22 k Ω 1/4-watt (red-red-orange) resistor between lugs 2 (S-3) and 4 (S-2).

- (✓) Refer to Pictorial 9-7 and use a pair of pliers to push the 1" steel blade into the smaller end of the nut starter until 1/8" remains exposed. Use this tool when you are instructed to adjust trimmer capacitors and the controls that are mounted on the circuit boards.



PICTORIAL 9-8

- (✓) Refer to Pictorial 9-8 and place a small tape "flag" on the long end of the coil adjustment tool. This will aid you in counting the number of turns of the tool during alignment.
- (✓) Set the jumper wires, the alignment load, the 50 ohm dummy load, the RF probe and the adjustment tools aside. They will be used during alignment of this Transceiver.

Refer to the following Pictorials (Illustration Booklet, Pages 12 and 13) to determine the location of components and circuit points in the following steps.

Front panel	Pictorial 8-1
Rear panel	Pictorial 8-2
VCO assembly	Pictorial 9-9
Synthesizer circuit board	Pictorial 9-10
Transmitter circuit board	Pictorial 9-11
Receiver circuit board	Pictorial 9-12

- () Turn the VOLUME control fully counterclockwise until it clicks (off position).
- () Turn the SQUELCH control fully counterclockwise.
- () Connect the Transceiver to your power source.
- () Make sure the crystals at Y401, Y402, Y403, and Y405 on the synthesizer circuit board are pressed firmly into their socket pins.

VCO ADJUSTMENT

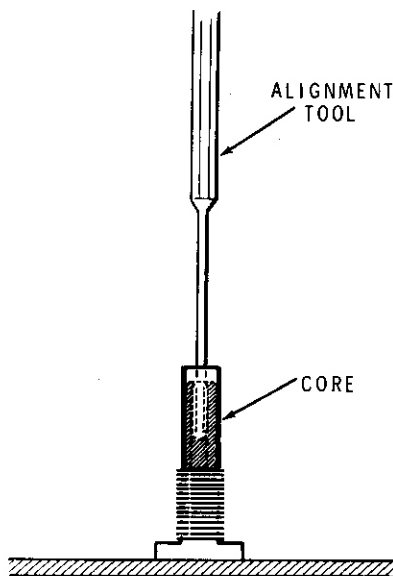

Detail 9-9A

- () Preset trimmer capacitor C511 on the VCO circuit board to mid capacity (metal part as shown in the inset drawing on Pictorial 9-9).
- () Refer to Detail 9-9A and use the coil adjustment tool to turn the core of L501 on the VCO assembly counterclockwise until the top of the core extends about 1/8" from its coil form.

NOTE: The circuits in this Transceiver are designed to operate properly over any 2 MHz segment within the range from 143.500 MHz to 148.500 MHz. Before you proceed, select the segment in which you wish to operate and write down the upper and lower limits of that segment in the margin of this page. Be sure to include the transmitter offset frequencies when you figure your 2 MHz range. Only the last four digits of the operating frequency are displayed on the switches. A setting of 6.940 is actually **146.940** MHz, etc.

- () Set the frequency selector switches to the center of your 2 MHz segment.
- () Set the MODE switch to SIM.

- () Turn the Transceiver on. The Synth Lock lamp should light.
- () **Slowly** adjust the slug in coil L501 clockwise until the Synth Lock lamp goes out. NOTE: The top of the slug should be almost flush with the top of the coil form.
- () Push the connector on the end of the black jumper wire onto TP402 on the synthesizer circuit board. Then connect the alligator clip to the chassis.
- () Push the 50 ohm dummy load (two 100 ohm resistors prepared earlier) into the ANT socket on the rear panel.

NOTE: Depress the microphone button only long enough to make the following adjustments.

- () Depress the microphone button. The Synth Lock lamp should light briefly and then go out. If it stays on, adjust coil L501 slightly until the lamp goes out.
- () Depress the microphone button and use a VTVM to measure the voltage at TP401 on the synthesizer circuit board, and adjust coil L501 for an indication of 2.2 volts.
- () Remove the jumper wire you connected between TP402 and the chassis.

NOTE: DO NOT press the microphone button when you perform the next step.

- () With the VTVM still connected to TP401, adjust trimmer capacitor C511 on the VCO circuit board for 2.2 volts.
- () Turn the Transceiver off.

TRANSMITTER ALIGNMENT

- () Set the frequency selector switches to the center of your 2 MHz segment and set the MODE switch to SIM, if this has not already been done.
- () Unplug the cable from J102 on the transmitter circuit board.
- () Plug the alignment load (51 ohm resistor and phono plug) into J102.
- () Turn the slugs in coils L101 and L102 counterclockwise until the top of the slugs are flush with the top of the coil forms. Then turn each slug clockwise 9 turns.
- () Turn the Transceiver on.
- () Connect the probe of your VTVM to TP101 on the transmitter circuit board.
- () 1. Depress the microphone button and adjust coils L101 and L102 for maximum meter indication. Repeat this adjustment two or three times. Write down the final meter reading in the margin next to this step. .99V
- () 2. Adjust coil L101 clockwise 1/8 turn. Then depress the microphone button and adjust coil L102 for a maximum meter indication. If the meter indication is the same as it was in step 1, or higher, repeat this step. If the meter indication is less than it was in step 1, adjust coil L101 counterclockwise 1/8 turn and readjust coil L102 for a maximum meter indication.
- () 3. Move the VTVM probe from TP101 to TP102.
- () 4. Depress the microphone button and adjust coils L103 and L104 for maximum meter indication. Repeat this adjustment two or three times.
- () 5. Move the VTVM probe from TP102 to TP103.
- () 6. Depress the microphone button and adjust coil L105 for a maximum meter indication.
- () 7. Move the VTVM probe from TP103 to TP104.
- () 8. Depress the microphone button and adjust coils L105, L106, and L107 for maximum meter indication. Repeat this adjustment two or three times.
- () 9. Move the VTVM probe from TP104 to TP101 and repeat steps 1 through 8.
- () Turn the Transceiver off.
- () Disconnect your VTVM from the Transceiver.
- () Unplug the alignment load from J102 on the transmitter circuit board and reconnect the cable coming from the power amplifier circuit board to J102.

10 MHz OSCILLATOR ADJUSTMENT

NOTE: The 10 MHz oscillator is divided down to provide the 833.333 Hz signal which determines the spacing between adjacent channel frequencies (when it is multiplied by 6). It is very important that this oscillator be set as accurately as possible, since any error will accumulate across the band. Two methods of adjustment are given, in the order of preference.

ALIGNMENT WITH WWV

- () Tune a short-wave receiver to WWV on 10, 15, 20, or 25 MHz. Use the highest frequency that you can receive in your area.
- () Turn the Transceiver upside down, if this has not already been done.
- () Remove 1/4" of insulation from one end of a suitable length of insulated wire. Then wrap this end of the wire around TP108 on your transmitter circuit board.
- () Position the free end of the wire coming from TP108 near the antenna input on your receiver.
- () Turn the Transceiver on.

- () Adjust trimmer C144, on the transmitter circuit board, for a zero beat with WWV (during a time when no tone is being transmitted). The frequency may shift slightly when you remove the alignment tool, so be sure the zero beat occurs AFTER you remove the tool.
- () Turn the Transceiver off and remove the insulated wire.

ALIGNMENT WITH A FREQUENCY COUNTER

NOTE: The frequency counter must have a crystal time base, recently checked for accuracy with WWV, and must read out to ± 1 Hz.

- () Connect the frequency counter to TP108 on the transmitter circuit board.
- () Turn the Transceiver on.
- () Adjust trimmer capacitor C144, on the transmitter circuit board, for a reading of 10.000,000 MHz. Check this reading after you remove the adjustment tool from the trimmer.
- () Turn the Transceiver off and disconnect the frequency counter.

POWER AMPLIFIER ADJUSTMENT

NOTE: Make sure all the screws are in the rear panel before you attempt to align the power amplifier.

Use the S meter on the front panel for an indication of relative power output. If you have an in-line wattmeter (capable of accurate readings at the operating frequency), connect the wattmeter between the 50 ohm dummy load and the ANT socket on the rear panel.

If you find it necessary to gain access to the component side of the PA (power amplifier) circuit board, refer to "PA Circuit Board Access" in the "In Case of Difficulty" section of this Manual.

- () Refer to Pictorial 8-2 (in the Illustration Booklet) and turn each trimmer capacitor fully clockwise (tighten each trimmer only until you feel resistance). Then turn each trimmer counterclockwise as follows:

trimmer at A	1/4 turn
trimmer at B	3/4 turn
trimmer at C	3/4 turn
trimmer at D	1 turn
trimmer at E	1/4 turn

- () Locate the free end of the short shielded cable coming from the PA circuit board. Then plug it into J102 on the transmitter circuit board, if this has not already been done.
- () If it has not already been done, connect the 50 ohm dummy load to the ANT socket on the rear panel (either direct or through an in-line wattmeter).
- () Be sure the MODE switch is at SIM.
- () Set the frequency selector switches to the center of your 2 MHz segment, if this has not already been done.

NOTE: Unless you are directed otherwise, do not depress the microphone button for more than 30 seconds continuous. Release the microphone button after you make each adjustment. DO NOT adjust any of coils L101 through L107 on the transmitter circuit board for maximum output. You should only adjust these coils by following the procedure under "Transmitter Alignment."

Refer to Pictorial 8-2 for the following steps.

- () Turn the Transceiver on.
- () Depress the microphone button. The meter should indicate half of one scale division or more. If there is no meter indication, adjust trimmer capacitor A or B (or both) until there is some indication on the meter.
- () Depress the microphone button and adjust the trimmer capacitors, through the rear panel holes, for a maximum meter indication. Use the following adjustment sequence: A, B, C, D, E, D, C, A, B. Remember to observe the 30 second limit when you depress the microphone button.
- () Try different settings of trimmer capacitors C and D to obtain a maximum meter indication.
- () Again adjust trimmer capacitors A and B for a maximum meter indication. NOTE: Do not adjust trimmer capacitor A any further counterclockwise than necessary to obtain maximum power output.
- () Allow the dummy load to cool to room temperature.
- () Depress the microphone button for 20 seconds. The meter indication should be between the first scale division and midscale. At the end of 20 seconds, the dummy load resistors should be too hot to touch.
- () Turn the Transceiver off.

RECEIVER ALIGNMENT

Refer to Pictorials 9-10 and 9-12 in the Illustration Booklet for the location of the coils called out in the following steps.

NOTE: Read the next step completely before you actually perform the step. Then perform the step carefully; you may need to refer to the chart later.

(✓) Adjust the slug in each of the following coils (on the receiver and synthesizer circuit boards) counterclockwise until the top of the slug is flush with the top of the coil form, or until you encounter resistance to further adjustment. Count the number of turns that each coil requires to accomplish this and write the number, to the nearest 1/4 turn, in column A of the following chart.

COIL	A	B	C
L201		2	
L202		3-3/4	
L203		2	
L204		7-1/2	
L205		1-1/2	
L206		-1	
L207		1/2	
L208		2	
L209		1	
L210		2	
L212		0	
L213		0	
L402		1	
L403		1	

(✓) Add the number you entered in column A to the number shown in column B and write the sum in column C for each coil.

(✓) Adjust the slug in each coil clockwise by the number of turns in column C.

NOTE: Refer to Pictorial 9-13 for the location of the RF probe pins called out in the following steps.

() Push the PCB connector on the red jumper wire onto pin C of the RF probe.

() Temporarily disconnect the green wire from pin P on the receiver circuit board. Then push this wire onto the PCB pin on the free end of the red jumper wire (coming from the RF probe).

() Push the PCB connector on the end of the black jumper wire onto pin B of the RF probe. Connect the alligator clip on the other end of the wire to the chassis.

() Temporarily disconnect the inner lead of the shield cable from pin C on the receiver circuit board and push the connector on this wire onto pin A of the RF probe.

() Set the frequency selector switches to 145.000, 146.000, or 147.000 (whichever is nearest the center of your 2 MHz segment).

() Make sure the RF probe assembly is not touching any wires or components which could cause a short circuit.

() Turn the Transceiver on.

() Adjust coils L402 and L403 on the synthesizer circuit board for a maximum indication on the S meter.

() Turn the Transceiver off.

() Disconnect the inner shielded cable lead from pin A of the RF probe and reconnect it to pin C on the receiver circuit board.

() Hold the RF probe by the ground lug and touch the bare wire extending from lug 1, to gate 2 (G2) of transistor Q202 on the receiver circuit board.

() Turn the Transceiver on.

() Adjust coils L212 and L213 (in that order) on the receiver circuit board for maximum deflection on the S meter. **NOTE:** These two coils interact. When they are properly adjusted, the slugs in these coils will be at approximately the same position.

() Turn the Transceiver off.

- () Disconnect the RF probe from the Transceiver and plug the green harness wire back onto pin P of the receiver circuit board.
 - () Temporarily unplug the shielded cable from pins A and B on the receiver circuit board.
 - () Connect the inner lead at one end of the shielded **jumper** wire to TP106 and connect the shield lead to TP107 on the transmitter circuit board.
 - () Connect the inner lead at the free end of the shielded jumper wire to pin A and connect the shield lead to pin B on the receiver circuit board.
 - () Refer to the inset drawing on Pictorial 9-11 and adjust trimmer capacitor C147 on the transmitter circuit board to minimum capacity.
 - () Turn the Transceiver on. The S meter should indicate up-scale and/or the receiver should show quieting (a reduction in noise from the speaker). NOTE: You can check this by changing the setting of the center frequency selector switch to 1 and back to zero. The receiver should be quieter when you have the switch in the zero position. If not, adjust trimmer capacitor C435 on the synthesizer circuit board until it is.
- NOTE: If the meter goes beyond midscale in the next step, adjust C147 on the transmitter circuit board as necessary to reduce the meter reading. If the meter still goes past midscale, detune coil L207 clockwise, as necessary, to keep the meter below midscale.
- () Adjust coils L201 through L209 on the receiver circuit board for a maximum indication on the S meter. NOTE: It may be necessary to begin the alignment by adjusting these coils for maximum quieting (least noise) until there is enough signal to cause a meter indication.
 - () Repeat the above step several times until there is no further improvement. NOTE: Coil L204 may have two peaks. If yours does, use the peak that occurs with the slug nearest the circuit board.
 - () Adjust coil L207 for maximum indication on the S meter.
 - () Turn the Transceiver off.
 - () Remove the shielded jumper wire between TP106 and TP107 on the transmitter circuit board and pins A and B on the receiver circuit board.
 - () Reconnect the inner wire of the shielded cable coming from the PA circuit board to pin A and the shield wire to pin B on the receiver circuit board.
 - () Turn the Transceiver on.
 - () Adjust coil L210 on the receiver circuit board for maximum noise.
 - () Turn the Transceiver off.



OFFSET OSCILLATOR ADJUSTMENT

Receiver Offset Oscillator

NOTE: You will now adjust the 21.55 MHz receiver offset oscillator and quadrature coil. Two methods are given. The first method is best, but the second method is acceptable.

ALIGNMENT WITH A FREQUENCY COUNTER

NOTE: The frequency counter you use for this adjustment must be capable of counting up to at least 25 MHz.

- Attach the frequency counter probe to pin C on the synthesizer circuit board.
- Turn the Transceiver on.
- Set the frequency selector switches to one of the settings in the table below (use a setting that falls within your 2 MHz segment). Then adjust C435 on the synthesizer circuit board until the counter indicates the frequency shown.

FREQUENCY SELECTOR SWITCHES	FREQUENCY AT PIN C
145.000 MHz	22.383,333 MHz
146.000 MHz	22.550,000 MHz
147.000 MHz	22.716,667 MHz

- Disconnect the frequency counter from pin C.
- Connect the Transceiver to a suitable antenna. Then readjust coil L210 on the receiver circuit board for the best audio quality of a received signal.
- Turn the Transceiver off.

ALIGNMENT WITH AN ACCURATE ON-THE-AIR SIGNAL

NOTE: Most repeaters are kept to tight frequency tolerances. It is desirable to use a repeater station in the next step, if possible.

- Connect the Transceiver to a suitable antenna and set the frequency selector switches to the frequency of a station of known accuracy.
- Turn the Transceiver on.
- Adjust trimmer capacitor C435 on the synthesizer circuit board and coil L210 on the receiver circuit board for the best audio quality.
- Turn the Transceiver off.

Transmitter Offset Oscillators

NOTE: You will now adjust the transmitter offset oscillators. Four methods are outlined below in the order of preference. Use the method that you can perform with your available equipment.

METHOD #1

NOTE: If your frequency counter will not operate as high as the 2-meter band, proceed to "Alternate Method."

- Connect the 50 ohm dummy load to the ANT socket on the rear panel.
- Set the frequency selector switches to the center of your 2 MHz segment.
- Be sure the MODE switch is at SIM.



- () Connect an accurate frequency counter across the dummy load. CAUTION: Since as much as 30 volts may be present at the ANT socket, and many counters have a 2-volt maximum input, use a suitable attenuator or you may damage the counter. Consult the instruction book for your counter.

- () Turn the Transceiver on.

NOTE: When you perform the adjustments in the next seven steps, adjust the trimmers as close as possible to the proper frequency.

- () Depress the microphone button and adjust trimmer capacitor C425 on the synthesizer circuit board until the counter indication agrees with the setting of the frequency selector switches.
- () Place the MODE switch in the -600 position.
- () Depress the microphone button and adjust trimmer capacitor C422 until the counter indication is 600 kHz less than the setting of the frequency selector switches.
- () Place the MODE switch in the +600 position.
- () Depress the microphone button and adjust trimmer capacitor C428 until the counter indication is 600 kHz higher than the setting of the selector switches.

NOTE: Perform the next two steps only if you have an auxiliary crystal installed at Y401.

- () Place the MODE switch in the AUX position.
- () Depress the microphone button and adjust trimmer capacitor C432 until the counter indicates the proper transmitter frequency.
- () Turn the Transceiver off and disconnect the frequency counter from the dummy load.

Alternate Method

NOTE: The frequency counter you use for this adjustment must be capable of counting up to at least 25 MHz.

- () Disconnect the white-brown wire from pin H on the transmitter circuit board.
- () Connect the frequency counter probe to pin C on the synthesizer circuit board.
- () Turn the Transceiver on.
- () Place the MODE switch in the SIM position.
- () Set the frequency selector switches to one of the settings in the table below (use a setting that falls within your 2 MHz segment).

FREQUENCY SELECTOR SWITCHES	FREQUENCY AT PIN C
145.000 MHz	24.166,667 MHz
146.000 MHz	24.333,333 MHz
147.000 MHz	24.500,000 MHz

- () Depress the microphone button and adjust trimmer capacitor C425 until the counter indicates the frequency shown in the above table.
- () Release the microphone button.
- () Place the MODE switch in the -600 position.

- () Depress the microphone button and adjust trimmer capacitor C422 until the counter indicates the frequency shown in the table below.

FREQUENCY SELECTOR SWITCHES	FREQUENCY AT PIN C
145.000 MHz	24.066,667 MHz
146.000 MHz	24.233,333 MHz
147.000 MHz	24.400,000 MHz

- () Release the microphone button.
- () Place the MODE switch in the +600 position.
- () Depress the microphone button and adjust trimmer capacitor C428 until the counter indicates the frequency shown in the table below.

FREQUENCY SELECTOR SWITCHES	FREQUENCY AT PIN C
145.000 MHz	24.266,667 MHz
146.000 MHz	24.433,333 MHz
147.000 MHz	24.600,000 MHz

- () Release the microphone button.

NOTE: Perform the next two steps only if you have an auxiliary crystal installed at Y401.

- () Place the MODE switch in the AUX position.

- () Depress the microphone button and adjust trimmer capacitor C432 until the counter indicates the frequency shown in the table below.

FREQUENCY SELECTOR SWITCHES	FREQUENCY AT PIN C
145.000 MHz	.833,333 MHz + f_{XTAL} (MHz)
146.000 MHz	1.000,000 MHz + f_{XTAL} (MHz)
147.000 MHz	1.166,667 MHz + f_{XTAL} (MHz)

- () Release the microphone button.
- () Turn the Transceiver off.
- () Reconnect the white-brown wire to pin H on the transmitter circuit board.

METHOD #2

Use the facilities of a commercial two-way radio shop.

METHOD #3

Use a receiver of known frequency accuracy which has a metered discriminator. Tune the receiver to each transmit frequency and adjust each trimmer capacitor for an on-frequency indication.

METHOD #4

Adjust each trimmer capacitor for an acceptable modulation quality as judged by several other amateur radio operators.

DEVIATION ADJUSTMENT

If a deviation monitor meter is available, adjust control R119 on the transmitter circuit board for 4.5 to 5 kHz of FM deviation. A good way to accomplish this is to whistle a steady tone into the microphone.

If a deviation monitor meter is not available, use on-the-air checks with other amateur operators. Check with three or four stations to get a consensus of opinion on recaptured audio in their receivers. NOTE: If

the operator with which you are checking has an old, surplus, commercial piece of equipment, it may have been designed to receive 15 kHz FM deviation signals. In this case, you may get a report of low-level recaptured audio. Attempting to increase the deviation for this type of receiver will cause phase distortion or may even close the squelch on narrow bandwidth receivers designed for 5 kHz FM deviation signals.

TONE ADJUSTMENTS

NOTE: A frequency counter is required for the following adjustments.

- () Remove the white-brown wire from pin H on the transmitter circuit board.
- () Connect a frequency counter to TP105 on the transmitter circuit board.
- () Determine the continuous tone frequencies you desire. Consult a repeater directory, if necessary.

NOTE: When you make the following adjustments, try to set each tone as accurately as possible. Most repeaters that use a tone are quite critical as to what frequency will key them.

- () Place the TONE switch in position A.

- () Depress the microphone button and adjust control R125 on the transmitter circuit board for the desired tone.
- () Place the TONE switch in position B.
- () Depress the microphone button and adjust control R126 on the transmitter circuit board for the desired tone.
- () Place the TONE switch in position C.
- () Depress the microphone button and adjust control R127 on the transmitter circuit board for the desired tone.
- () Turn the Transceiver off and disconnect the frequency counter.
- () Reconnect the white-brown wire to pin K on the transmitter circuit board.

MICODER ADJUSTMENTS

If you purchased the Transceiver kit with the Micoder, proceed to that Manual and perform the "Adjustments."

This completes the alignment of your Transceiver. Proceed to "Final Assembly."

FINAL ASSEMBLY

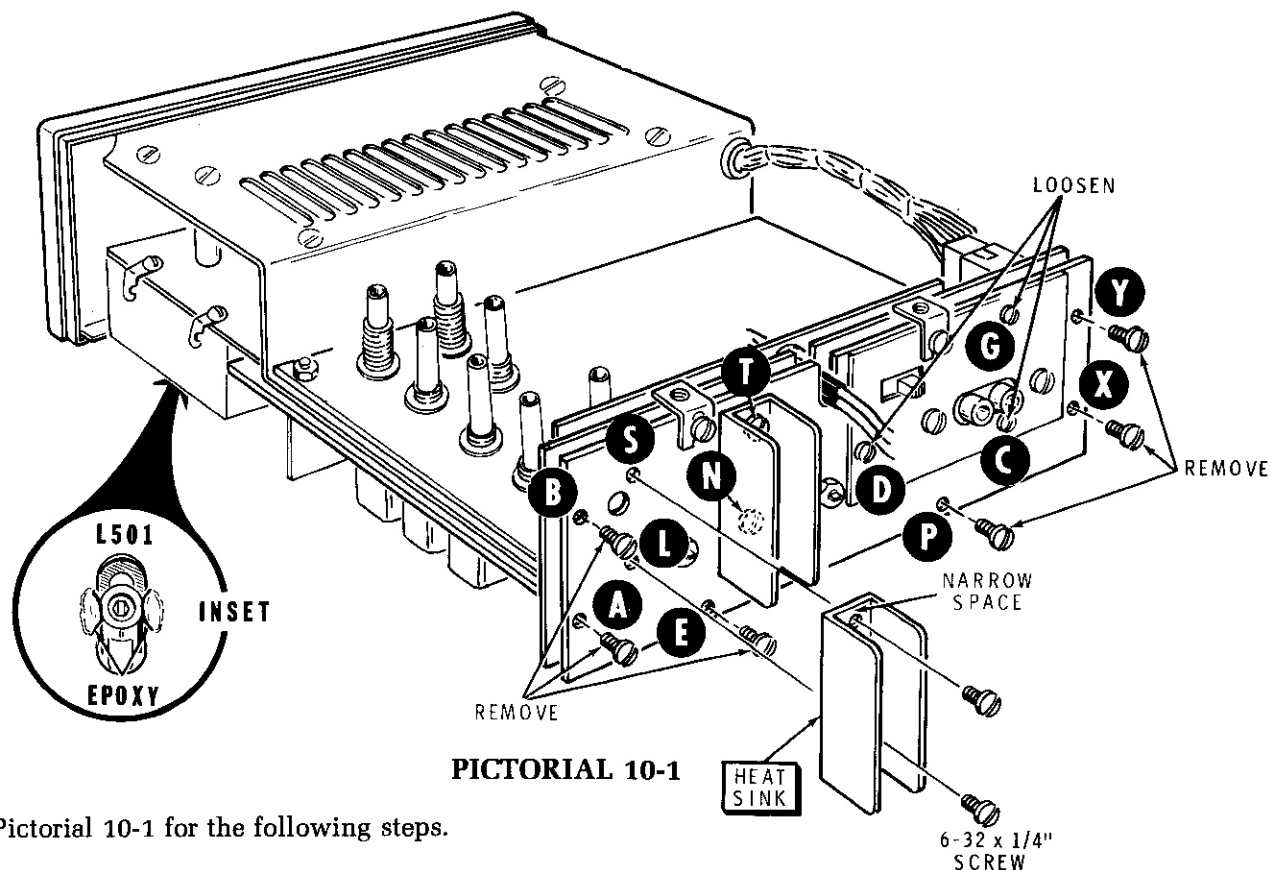

Refer to Pictorial 10-1 for the following steps.

- () Position the chassis as shown.

NOTE: If you wish, you may install an auxiliary crystal at this time. Before you order crystals from a supplier, refer to "Aux Crystal Information" in the "Operation" section of this Manual.

- () Identify the two heat sinks and four 6-32 × 1/4" screws. Note that one of the holes in each heat sink is closer to the edge.
- () Rub silicone grease over the side of a heat sink that will be against the PA assembly. Then install the heat sink on the PA assembly with 6-32 × 1/4" screws at N and T.
- () Similarly install the remaining heat sink with 6-32 × 1/4" screws at L and S.
- () **IMPORTANT:** To suppress the radiation of harmonics and spurious frequencies, there must be very good contact between the rear panel, the PA circuit board, and the chassis.
- () Remove the six 6-32 × 1/4" screws at A, B, E, P, X, and Y in the PA assembly. Discard these screws.
- () Loosen the 4-40 × 1/8" screws at C, D, and G. **CAUTION:** These screws are very short and can be loosened only slightly.
- () Turn the chassis right-side-up.
- () Use a soft cloth to wipe fingerprints etc. from around the hole where the coil extends from the VCO cover. Do not scrape or use any solvent.
- () Open the remaining package of epoxy. Then follow the directions packed with the epoxy to thoroughly mix it together.
- () Refer to the inset drawing and use a toothpick or similar object to put a bead of epoxy around coil L501. Use only enough epoxy to secure the coil

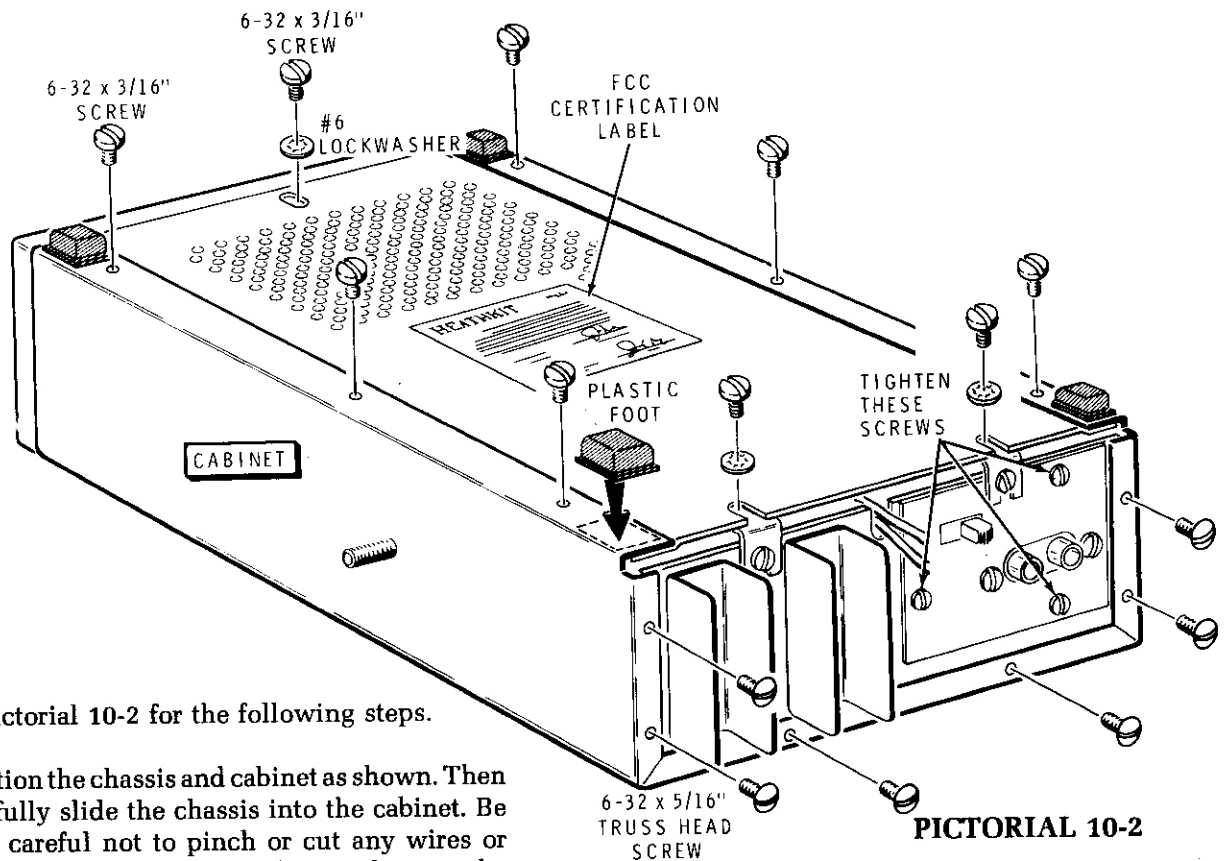

Refer to Pictorial 10-2 for the following steps.

- () Position the chassis and cabinet as shown. Then carefully slide the chassis into the cabinet. Be very careful not to pinch or cut any wires or cables. **IMPORTANT:** Check to make sure the Squelch control terminals do not touch the underside of the cabinet.
- () Secure the chassis to the cabinet. Install six 6-32 \times 5/16" truss head screws through the cabinet and into the PA assembly. It may be necessary to shift the position of the panel plate slightly so it is not pinched.
- () Tighten the three 4-40 \times 1/8" screws to secure the panel plate to the PA assembly.

- () Refer to Detail 10-2A and slide the bottom plate into position between the chassis and the cabinet. Be very careful not to pinch or cut any wires or cables.
- () Secure the bottom plate to the cabinet with nine 6-32 \times 3/16" screws. Use #6 lockwashers on the three indicated screws.
- () Read, write in the Model Number, sign, and date the FCC certification label. Then carefully peel away the backing paper and press the label onto the bottom plate as shown in the Pictorial.

NOTE: In the following steps, be sure each foot is properly positioned before you allow it to touch the metal.

- () Remove the backing paper from a plastic foot and press the foot into place on one corner of the cabinet, as shown.
- () Similarly, mount a plastic foot on each remaining corner of the cabinet.

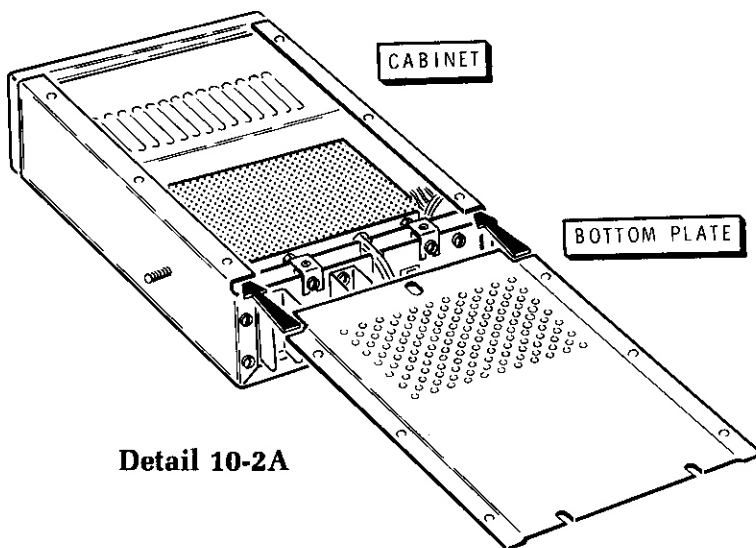

Detail 10-2A

This completes the "Final Assembly." Proceed to the "Installation" section of this Manual.

INSTALLATION

You can install this Transceiver in any location where a nominal 13.8 VDC supply is available (negative ground only). The usual power sources are a "12-volt" battery system or a power supply that furnishes DC from an AC source. Read the "Power Supply" discussion in the "Operation" section of this Manual.

Most installations can be defined as either a "fixed station" or as a "mobile station," although many operators use their Transceivers in both fixed and mobile service. A Heathkit AC power supply is available for use with this Transceiver in fixed station service. Mating power supply connectors are furnished for connection to both fixed and mobile power supply outputs.

We recommend that you use a low-loss transmission line of known quality. Some inexpensive cables have high losses, which would cause poor efficiency.

For mobile installation, a gimbal plate is included that provides a permanent mount for the gimbal bracket which holds the Transceiver. The plate has two sets of slots which provide versatility in the mounting position of the plate, and therefore the Transceiver. Both the gimbal bracket and the Transceiver can be easily removed. Plastic feet are provided for the gimbal bracket to protect supporting surfaces in fixed station when the gimbal bracket remains with the Transceiver.

Pictorial 11-1 (in the Illustration Booklet) shows a few positions in which you may mount the Transceiver in both fixed and mobile use.

CAUTION: When you connect your Transceiver to an antenna, DO NOT change any transceiver adjustments, as you have already aligned it to a 51 Ω load. All adjustments for antenna matching must be made to the antenna and transmission line, and NOT to the Transceiver.

GIMBAL BRACKET INSTALLATION

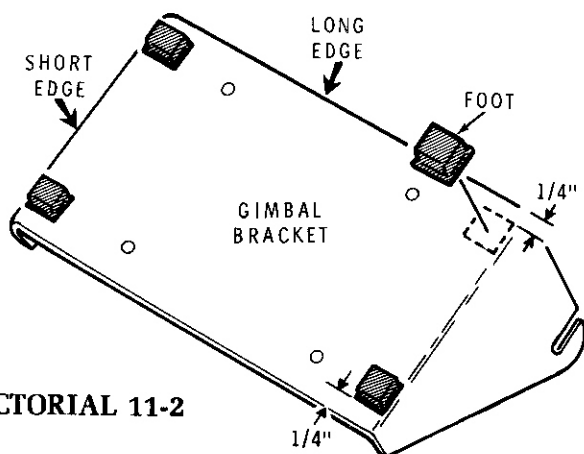

PICTORIAL 11-2

Refer to Pictorial 11-2 and turn the bracket upside down as shown. Then remove the paper backing from each of the feet and press them into place on the underside of the bracket. Be sure to keep 1/4" distance between the sides of the feet and the longer sides of the bracket, as shown. The edges of the feet should be flush with the shorter edges of the bracket.

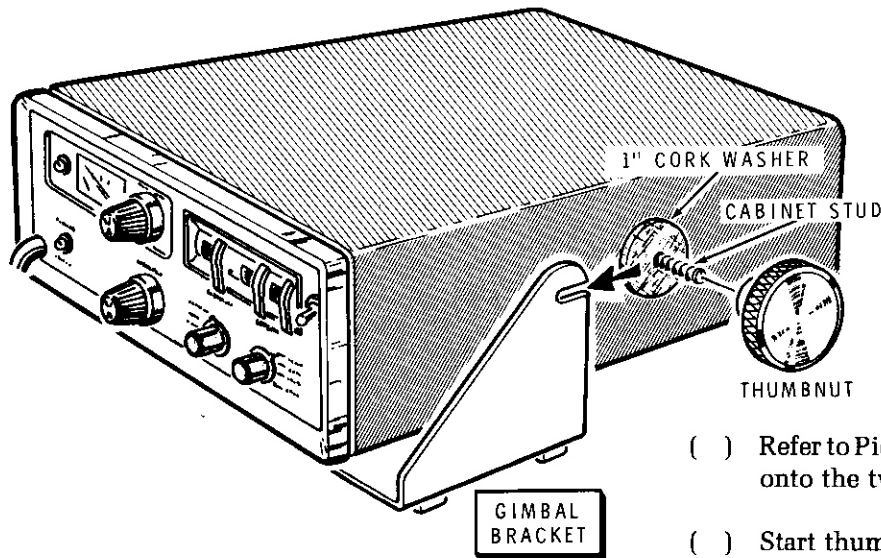

PICTORIAL 11-3

- () Refer to Pictorial 11-3 and place 1" cork washers onto the two cabinet studs.
- () Start thumbnuts onto the cabinet studs.
- () Place the Transceiver onto the gimbal bracket as shown, tilt it to the desired position, and tighten the thumbnuts.

FIXED STATION INSTALLATION

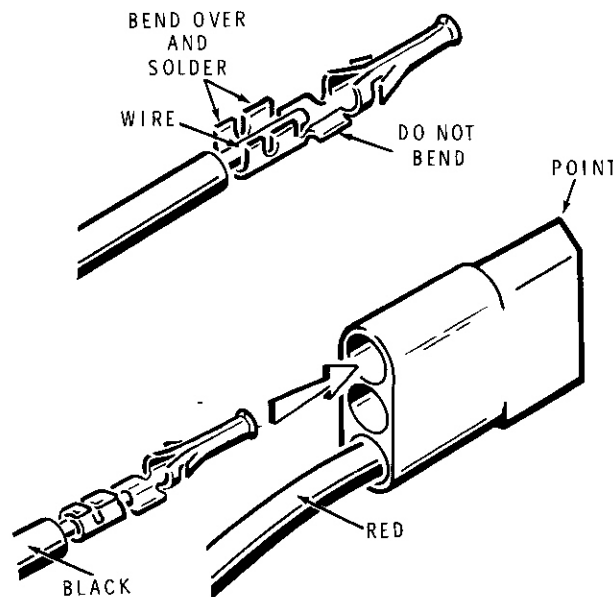

PICTORIAL 11-4

NOTE: In the following steps you will install a connector on the output wires of the Heathkit power supply for this Transceiver. The output has one red (positive) and one black (negative, or ground) wire.

- () If it has not already been done, remove 1/4" of insulation from the end of each of the power supply output wires. Twist the fine strands together and melt a **small** amount of solder on the bare wire ends.
- () Refer to Pictorial 11-4 and solder a female connector (#432-73) to the end of each of the two wires you prepared in the preceding step.
- () Position a male connector housing (#432-723) with the point up and push the female connector on the black wire into the upper hole, as shown, until the connector locks into place.
- () Similarly, push the connector on the red wire into the lower hole; leave the center hole open.
- () Plug the power supply connector into the Transceiver power connector.

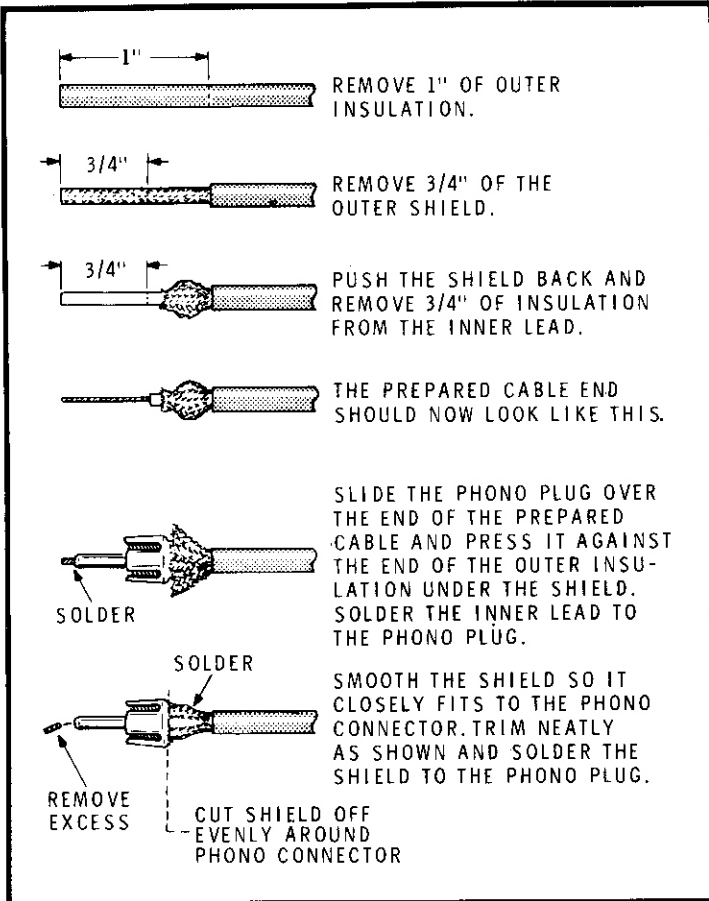

PICTORIAL 11-5

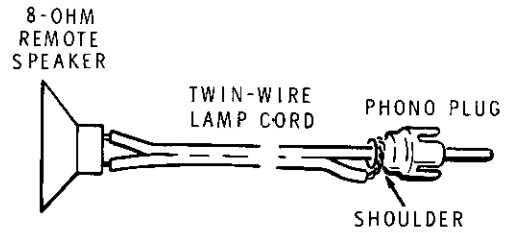

PICTORIAL 11-6

NOTE: Your Transceiver has an internal speaker. If you prefer, you can connect an external 8-ohm speaker to the Transceiver.

- () If you are going to use the Transceiver's internal speaker, push the rear panel slide switch to INT.
- () If you are going to use an external speaker, refer to Pictorial 11-6 and install a phono plug on the speaker leads. Connect the plug to the SPKR socket on the rear panel, and push the rear panel slide switch to EXT.

- () Refer to Pictorial 11-5 and, if it has not already been done, install a phono plug on your transmission line.
- () Connect the transmission line to the ANT connector on the rear panel.

This completes the "Fixed Station" installation instructions. If you are also going to use your Transceiver as a mobile station, proceed to the "Mobile Installation" section of this Manual. If you do not plan a mobile installation, proceed to the "Operation" section.

MOBILE STATION INSTALLATION

This section of the Manual will discuss the installation of the Transceiver in an automobile, but the same principles apply to installations in other types of conveyance, such as a boat, airplane, or snowmobile. Read the information before you install your Transceiver.

- () Make sure that the voltage output of your battery charging system is at least 12.6 volts and that it does not exceed 16 volts under any circumstances. If the voltage is not within these limits, have the system adjusted. See the "Power Supply" discussion in the "Operation" section of this Manual.

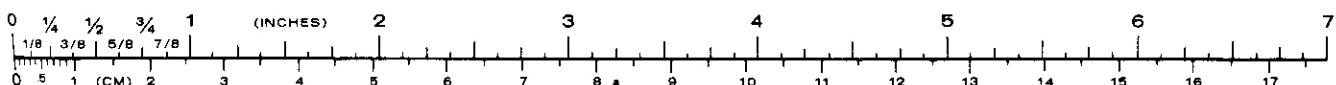

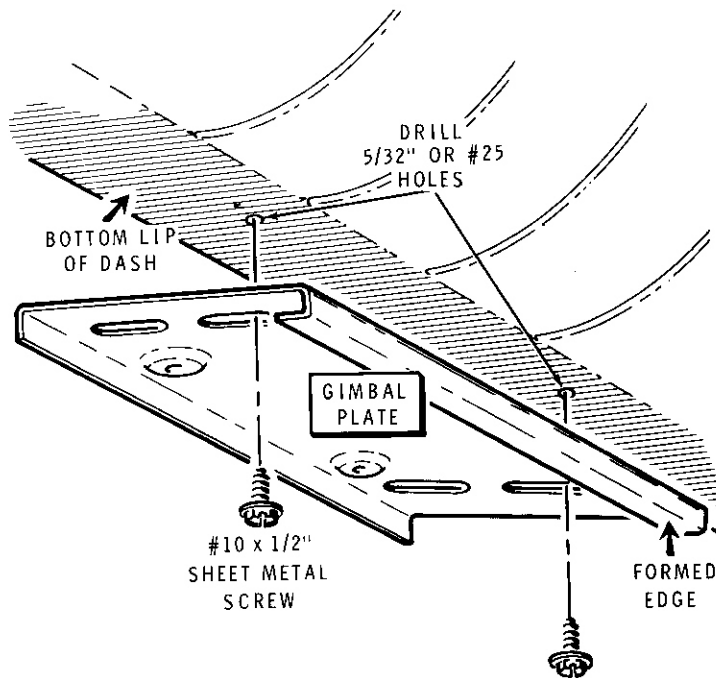

PICTORIAL 11-8

- Decide upon the power wire routing path. You can run the red power wire through an existing opening in the fire wall direct to the battery. Alternately, there may be an unused circuit available on the accessory fuse block of your automobile, and the power can be taken from this source. The ignition switch will usually control the accessory circuit. Also determine where you will connect the black (ground) power wire.

NOTE: If you prefer, you can install an additional fuse in the red power wire near the battery. The in-line fuse already installed will protect the Transceiver in either fixed or mobile installations; but will not, for example, protect the battery should the power wire short-circuit to the fire wall.

- Determine the routing of the antenna transmission line.

() Refer to Pictorial 11-7 (Illustration Booklet, Page 14), the "Installation X-Ray View," for a suggested arrangement of components and their interconnections. Then decide where and how you will mount your Transceiver. Look at Pictorial 11-1 (in the Illustration Booklet) for some under-the-dash mounting suggestions. A "home-brew" adapter could be made for the drive shaft hump, and the gimbal plate (or gimbal bracket) could be mounted on the adapter.

- Pictorial 11-8 shows the gimbal plate, which can be permanently mounted in the automobile. This gives you the option of removing the gimbal bracket from the passenger compartment when the Transceiver is not mounted there. Pictorial 11-9 and 11-10 show how the gimbal bracket, the gimbal plate, and the Transceiver fit together. You can remove the Transceiver by loosening the thumbnuts (and pulling apart the power line connector), and you can remove the gimbal bracket by removing the thumbscrews. Of course, you can attach the gimbal bracket permanently to the automobile and not use the gimbal plate. However, it is often convenient to be able to remove the gimbal bracket.

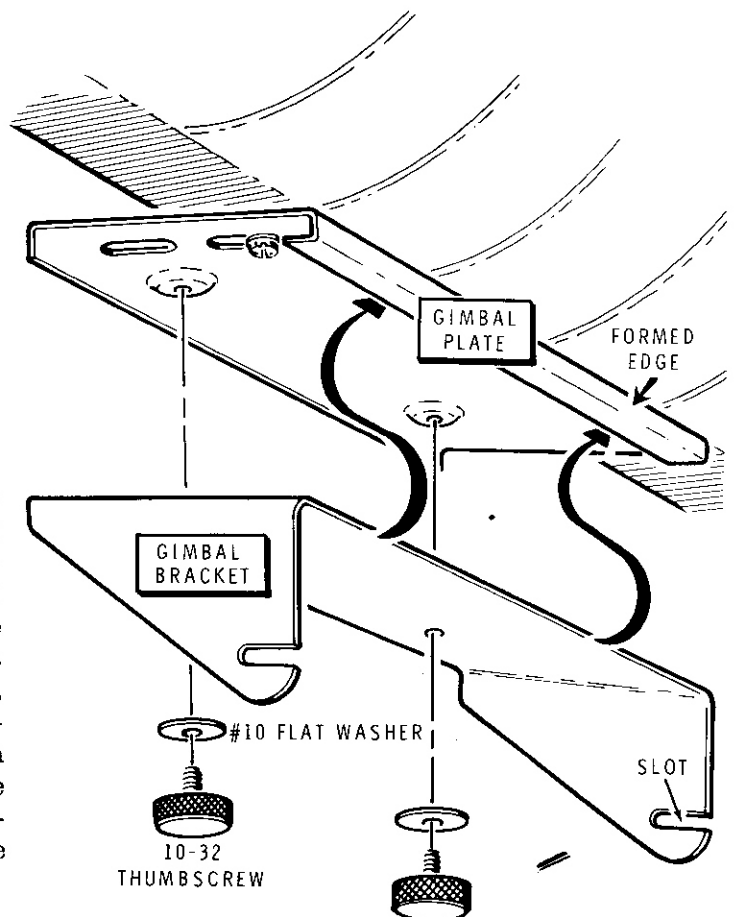

PICTORIAL 11-9

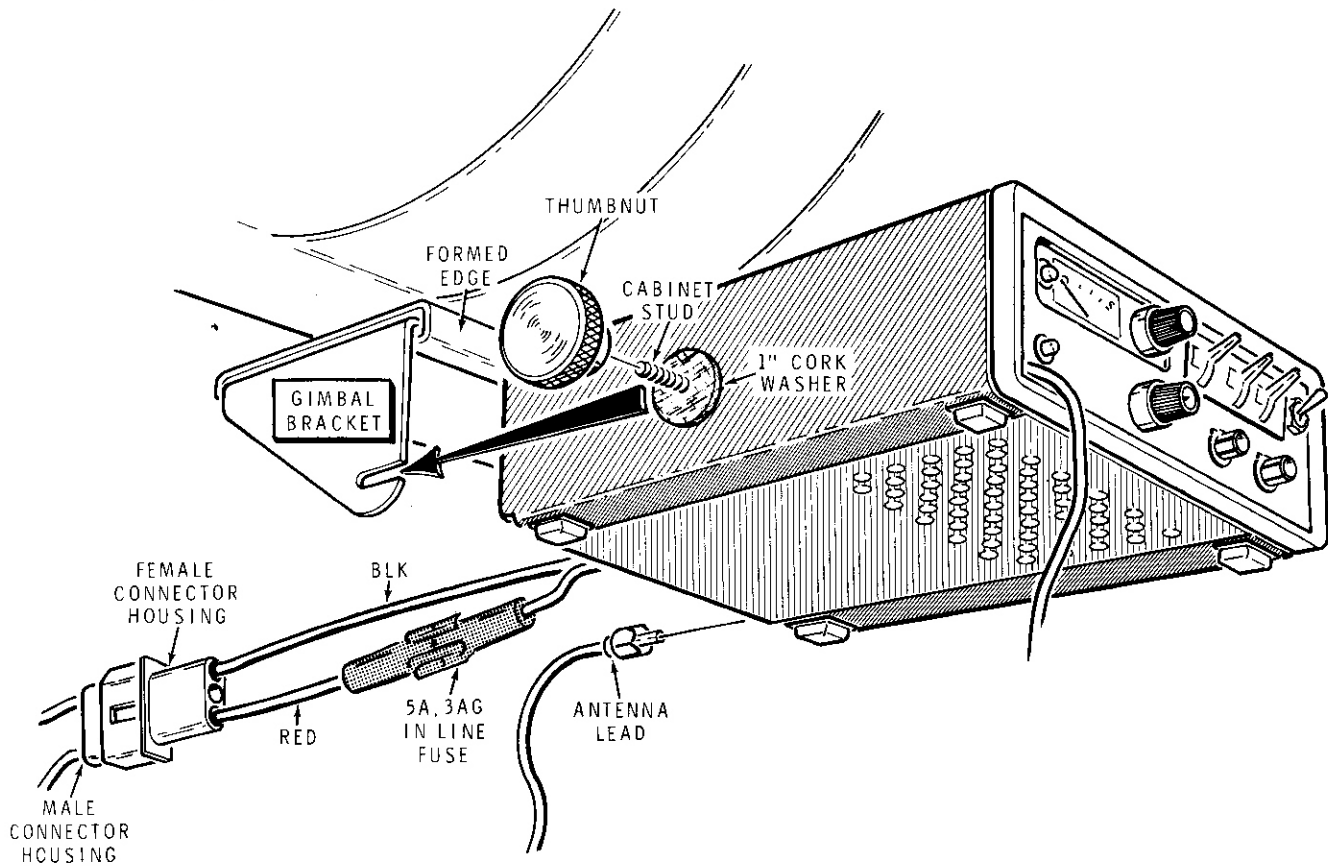

PICTORIAL 11-10

MOUNTING HARDWARE

- () If you are going to use the gimbal plate, refer to Pictorial 11-8 and use the gimbal plate as a template to drill two mounting holes in the lower lip of the dash. Use a 5/32" or a #25 bit.
- () Secure the gimbal plate to the dash with two #10 × 1/2" sheet metal screws. Use either pair of slots to position the plate as desired. NOTE: Four screws have been supplied in case they are needed in some installations.
- () Refer to Pictorial 11-9 and secure the gimbal bracket to the gimbal plate. Use #10 flat washers and 10-32 thumbscrews. The slots in the gimbal bracket may be toward the rear of the vehicle, if you prefer.

NOTE: Your Transceiver has an internal speaker. If you prefer, you can connect an external 8-ohm speaker to the Transceiver.

- () If you are going to use the Transceiver's internal speaker, push the rear panel slide switch to INT.
- () If you are going to use an external speaker, refer to Pictorial 11-6 on Page 129 and install a phono lug on the speaker leads. Connect the plug to the SPKR socket on the rear panel, and push the rear panel slide switch to EXT.
- () Refer to Pictorial 11-10, loosen the two thumbnuts, insert the studs on the sides of the Transceiver into the slots in the gimbal bracket, and tighten the thumbnuts.

POWER WIRING

You can connect the power wire to the battery, although it is possible there is an unused terminal available on the accessory fuse block of your automobile. In this case, connect the red power wire to the unused terminal. (A 1/4" push-on connector is furnished. Any other type of connector you may require should be purchased locally.) The automobile ignition switch will usually control this circuit in the same manner as the other accessory circuits. To make sure the circuit is suitable, connect a voltmeter between the terminal and the automobile body and turn the ignition key to either "on" or to "accessory." If there is no voltage reading, check to make sure a fuse is actually installed.

On some automobiles, the starter relay terminal is a convenient place to obtain battery voltage. If you decide to use this connection, secure locally a solder lug which will fit the relay terminal.

If you used an AC power supply to align your Transceiver and are now making a mobile installation, install a male connector on the large red and large black power wires by performing the first four steps under "Fixed Station Installation" on Page 128. Then perform numbered steps 1 through 8 that follow.

If you used your 12-volt battery as a power source for the alignment of your Transceiver, you will already have the male connector housing installed on the red and the black power wires. In this case, perform only the following steps, but perform all of them.

1. () Remove and set aside the fuse from the Transceiver's fuseholder.
2. () Temporarily place the Transceiver in its permanent position.
3. () Plug the male connector on the power wires into the female connector on the Transceiver.
4. () Route the red wire to your battery (or the accessory fuse block). Allow a little extra length for strain relief and cut the wire to length.

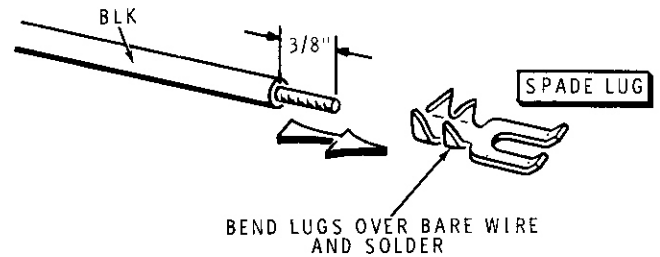

PICTORIAL 11-11

5. () Install the required type of connector on the red wire and connect it to your battery or the fuse block.
 6. () Route the black wire from the power connector to the ground point you have selected. Allow a little extra length for strain relief and cut the wire to length.
 7. () Refer to Pictorial 11-11 and install a spade lug (#259-22) on the end of the black wire and secure the lug to the ground point with a #6 sheet metal screw.
 8. () Turn the VOLUME control counterclockwise until it clicks and then replace the fuse in the fuseholder.
- () Turn the VOLUME control clockwise until it clicks. The meter face should light, indicating that you have correctly made your power connection.
- () Start your automobile engine.
- () Check for alternator whine in the receiver and transmitter.

NOTE: If alternator whine exists, refer to the ARRL Handbook or your local automotive garage for assistance in locating the problem.

- () Turn the Transceiver off.

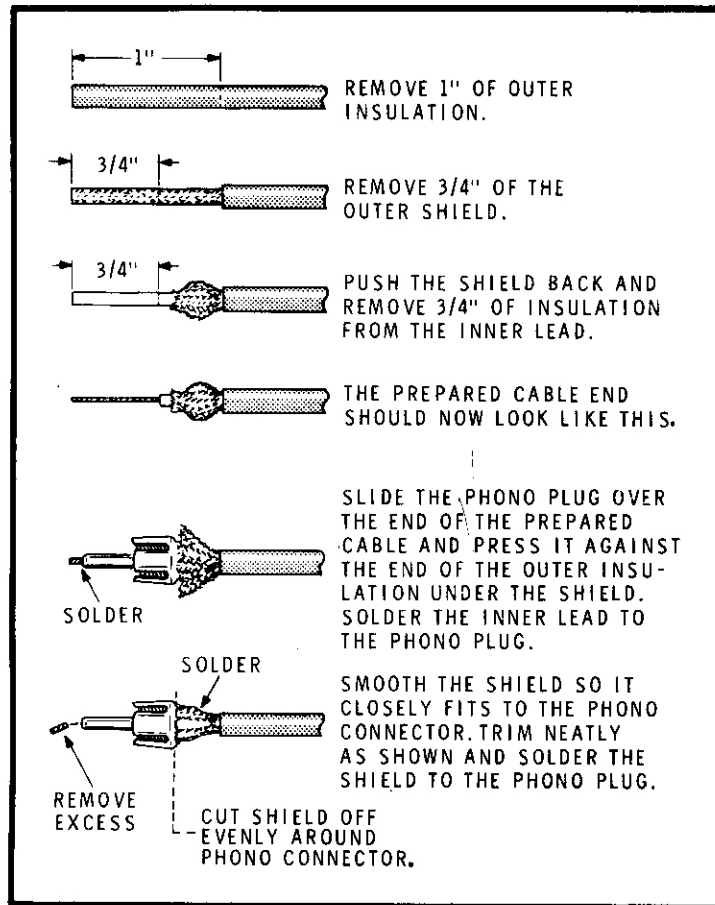

PICTORIAL 11-12

- () Refer to Pictorial 11-12 and install a phono plug on the transmission line coming from your antenna.
- () Push the phono plug into the ANT socket on the rear panel.

NOTE: A microphone clip and two #6 × 3/8" sheet metal screws to mount it have been furnished. Mount the clip at a convenient location.

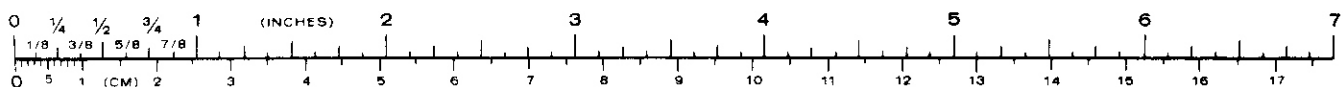

ANTENNAS

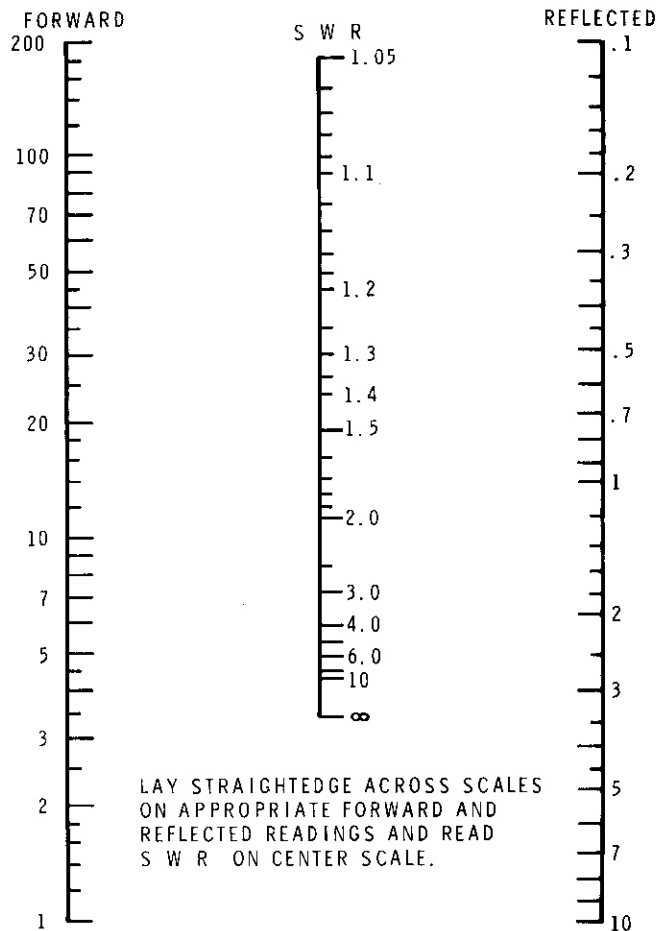

SWR CALCULATOR

PICTORIAL 11-13

Two-meter antennas are available commercially from the Heath Company, and others, or you can construct your own. A discussion of antennas is beyond the scope of this Manual. Refer to the several good handbooks on the subject, one of which is the ARRL Antenna Book, available from most radio equipment dealers or from ARRL, 225 Main Street, Newington, CT. 06111.

In the absence of an SWR (standing wave ratio) meter capable of accurate measurements at two meters, use a directional wattmeter for forward and reflected power readings. You can convert these readings to SWR by use of the SWR Calculator, Pictorial 11-13. The optimum SWR is 1, but you will obtain good results at any reading less than 2. Higher ratios will not damage this Transceiver but are undesirable from an operational standpoint.

OPERATION

CONTROLS AND CONNECTIONS

Refer to Pictorial 12-1 (Illustration Booklet, Page 14) for the location and functions of front and panel controls, connections, and adjustment access points.

SPEAKER

If you use an external 8-ohm speaker, connect it to the rear panel SPKR socket and push the rear panel speaker switch to EXT. If you use the built-in speaker, make sure the rear panel speaker switch is at INT.

MICROPHONE

Use only the microphone supplied with the Transceiver.

Depress the Microphone switch to activate the transmit circuits; release the switch to receive.

SIGNAL METER

The front panel meter shows relative transmitted signal strength and relative received signal strength.

SQUELCH

To adjust the SQUELCH control, first turn it fully counterclockwise. Turn the Transceiver on and set the VOLUME control so you hear background noise at average volume. Then turn the SQUELCH control knob clockwise until the noise just disappears. Setting the SQUELCH control further clockwise requires a stronger received signal to break the squelch.

CHANNEL ACTIVITY INDICATOR

The amber LED (to the left of the meter) lights whenever the receiver is unsquelched.

SYNTH LOCK INDICATOR

The red LED lights whenever the synthesizer is unlocked. It will normally light briefly when you change

frequency, switch from transmit to receive, or switch from receive to transmit.

MODE SWITCH

The SIM (Simplex) position provides transmitter and receiver operation on the displayed frequency. In the -600 mode, the transmitter operates 600 kHz below the receiver frequency. In the +600 mode, the transmitter operates 600 kHz above the receiver frequency. An AUX (Auxiliary) position is provided for an alternate frequency split, should you require one. Do not use this position if you have not installed an auxiliary crystal because the transmitter will not operate.

TONE SWITCH

Some repeaters require a subaudible continuous access tone. This switch allows you to select one of three tones (adjustable internally) or a no-tone (off) condition. This switch should normally be OFF when you use simplex operation.

CHANNEL SELECTION SWITCHES

Use the lever switches to select the 1 MHz, 100 kHz, and 10 kHz digits of the desired receive frequency. Use the toggle switch to select either 0 kHz or 5 kHz. The left-hand lever switch must be set to 4, 5, 6, or 7 (also 3 or 8 for CAP or MARS operation). The displayed frequency is always the receiver frequency, and will be the transmit frequency only when the Mode switch is in the SIM (Simplex) position.

NOTE: You must add the displayed frequency to 140 MHz to obtain the correct operating frequency.

Example: 6.940 = 146.940

CAUTION: In the +600 or -600 modes, the transmitter frequency is 600 kHz higher or 600 kHz lower, respectively, than the receiver frequency. You must use care to avoid out-of-band transmission in these modes. A similar condition exists in the auxiliary mode, if it is used.

POWER SUPPLY

A DC voltage between 12.6 volts and 16 volts will operate the Transceiver. The voltage can be furnished by an AC-operated power supply or a 12-volt system, such as an automobile battery. The supply must have a negative ground and be capable of at least 2.6 amperes output. For fixed station use, the Heathkit Model HWA-2036-3 will sufficiently power this Transceiver at normal line voltages.

CAUTION: Before you connect this Transceiver to mobile "12-volt" power source, check the voltage at the battery with the engine running above a fast idle. The voltage **MUST NOT** exceed 16 volts or the Transceiver may be damaged.

AUX (AUXILIARY) CRYSTAL INFORMATION

If you desire to add a crystal to the AUX position to provide an alternate transmitter offset frequency, you should supply the crystal manufacturer with the following information:

Required Frequency, calculate as follows:

$$\text{Crystal Frequency} = 23.3333 \text{ MHz.} + \frac{\text{Desired offset (MHz)}}{6}$$

Example: For an offset of +400 kHz (transmitter .4 MHz higher than receiver),

$$f_{XTAL} = 23.3333 \text{ MHz} + \frac{.4 \text{ MHz}}{6} = 23.3999 \text{ MHz.}$$

Note that for negative offsets (transmitter below the receiver frequency), the required crystal frequency will be below 23.3333 MHz. In other words, you should change the plus (+) sign in the above formula to a minus (-).

Frequency tolerance	= ±.002% or better at 25°C.
Load Capacity	= 23 pF.
Series Resistance	= 40 Ω max. (0°C to 60°C).
Stability	= ±10 parts per million (0° to 50°C).
Holder	= HC-25U.
Holder pin size	= .040" dia.
Holder pin spacing	= .192".

NORMAL OPERATING CHARACTERISTICS

1. The relay will click when you turn the Transceiver on.
2. When you depress or release the microphone button, the Synth Lock lamp should light briefly.
3. If you attempt to operate outside the band or outside your selected 2 MHz segment, the relay will click briefly before lock-out is established.
4. The Channel Activity lamp may light briefly when you depress or release the microphone button.
5. A microphonic condition may occur at a few frequencies with the VOLUME control at a high setting and the Transceiver unquelled but not receiving a signal. This will not affect the performance under normal operating conditions.

IN CASE OF DIFFICULTY

Begin your search for any trouble that occurs after assembly by carefully following the steps listed below in the "Visual Tests." After you complete the "Visual Tests" refer to the Troubleshooting Charts.

NOTE: Refer to the "Circuit Board X-Ray Views" on Page 150 for the physical location of parts on the circuit board.

VISUAL TESTS

1. Recheck the wiring. Trace each lead with a colored pencil on the Pictorial as you check it. It is frequently helpful to have a friend check your work. Someone who is not familiar with the unit may notice something that you have consistently overlooked.
 2. About 90% of the kits that are returned to the Heath Company for repair do not function properly due to poor connections and soldering. Therefore, you can eliminate many troubles by reheating all connections to make sure they are soldered as described on Pages 28 and 29. Be sure there are no solder "bridges" between circuit board foils.
 3. Check to be sure all transistors and diodes are in their proper locations. Make sure each lead is connected to the proper point. Make sure that each diode band is positioned above the band printed on the circuit board.
 4. Check electrolytic capacitors to be sure their positive (+) mark is at the correct position.
 5. Check to be sure that each IC is properly installed in its socket, and that the pins are not bent out or under the IC. Also be sure the IC's are installed in their correct positions.
 6. Check the values of the parts. Be sure in each step that you wired the correct part into the circuit, as shown in the Pictorial. It would be easy, for example, to install a 22 k Ω (red-red-orange) resistor where a 2200 Ω (red-red-red) resistor should have been installed.
 7. Check for bits of solder, wire ends, or other foreign matter which may be lodged in the wiring.
 8. Look between each circuit board and the chassis to be sure all leads were cut off short.
 9. A review of the "Circuit Description" may also help you determine where the trouble is.
- If you have still not located the trouble after the "Visual Tests" are completed, and a voltmeter is available, check voltage readings against those shown on the Schematic Diagram. Read the "Precautions for Troubleshooting" before you make any measurements. NOTE: All voltage readings were taken with a high impedance voltmeter. Voltages may vary as much as $\pm 20\%$.
- NOTE: In an extreme case where you are unable to resolve a difficulty, refer to the "Customer Service" information inside the rear cover of this Manual. Your Warranty is located inside the front cover.

PRECAUTIONS FOR TROUBLESHOOTING

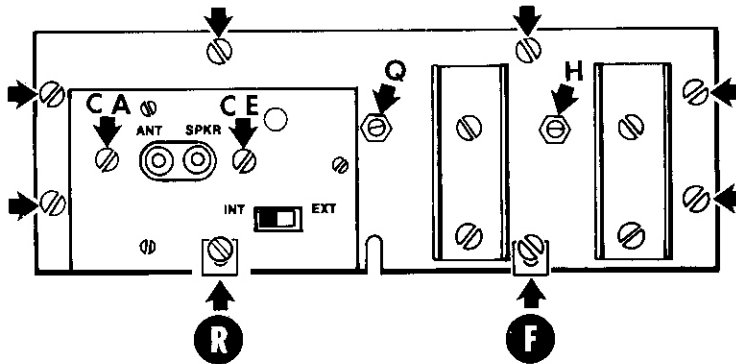

PICTORIAL 13-1

1. Use caution when you test IC and transistor circuits. Although they have almost unlimited life when used properly, they are much more vulnerable to damage from excessive voltage or current than other circuit components.
2. Be sure you do not short any terminals to ground when you make voltage measurements. If the probe should slip, for example, and short across terminals or voltage sources, it is very likely to cause damage to one or more IC's, transistors, or diodes.

PA CIRCUIT BOARD ACCESS

To gain access to the component side of the power amplifier circuit board after initial assembly, refer to Pictorial 13-1 and proceed as follows.

Dissassembly

- () Remove the 6-32 screws at CA and CE.
- () Hold the flats in the ends of the transistor studs with pliers to keep them from turning, and use the end wrench to remove the two 8-32 shoulder nuts from the transistor studs at H and Q.
- () Remove the eight 6-32 screws that hold the rear panel to the eight studs.

- () Lift off the rear panel.

Reassembly

- () Place the rear panel over the studs so the eight panel holes are aligned with the holes in the studs.
- () Turn the 8-32 nuts (which remained on the transistor studs) down against the transistors.
- () Start the eight 6-32 \times 1/4" screws into the studs. Tighten these screws firmly, but do not over-tighten them. NOTE: You will remove six of these screws when the cabinet is installed.
- () Insert two 6-32 \times 1/4" screws at CA and CE.
- () Reach in between the rear panel and the component side of the circuit board with a screwdriver and turn the 8-32 nuts on the transistor studs so they are snug against the back of the rear panel. DO NOT use the end wrench.
- () Replace the two 8-32 nuts on the transistor studs at H and Q. Again hold the end of the studs with pliers and tighten these nuts with the end wrench but DO NOT over-tighten them, as the threads of the brass studs can be damaged.

CHECKING TRANSISTORS AND DIODES

SILICON BIPOLAR TRANSISTORS

To check a transistor accurately, you should use a transistor tester. However, if one is not available, you can use an ohmmeter to determine the general condition of any one of the bipolar transistors in this kit. The ohmmeter you use must have at least 1 volt DC at the probe tips to exceed the threshold of the diode junctions in the transistor you are testing. Most vacuum tube voltmeters meet this requirement.

To check a transistor with an ohmmeter, proceed as follows:

1. Remove the transistor from the circuit.
2. Set the ohmmeter to the $R \times 1000$ range.
3. Connect one of the ohmmeter test leads to the base (B) of the transistor. Touch the other meter lead to the emitter (E) and then to the collector (C). Both readings should be the same, but may be either high or low. If one reading is high and the other low, the transistor should be replaced. (Use the Identification Chart on Page 154 to identify the transistor leads.)
4. Interchange the test leads and repeat step 3.

NOTE: In the unusual case when the readings are all low, or all high, no matter which ohmmeter lead is connected to the base, the transistor should also be replaced.

MOSFETs

Insulated gate type MOSFETs are used at Q201, Q203, and Q205 on the receiver circuit board and at Q408 on the synthesizer circuit board. Usually, any defect in these devices is an internal short circuit between the source and one of the gates. You can check them in the circuit with a high impedance voltmeter (10 megohms or higher). An abnormally low source voltage may indicate an internal short circuit.

DIODES

To check a diode, unsolder one end from the circuit board, pull the lead up and out of the circuit board hole, and proceed as follows:

1. Set the ohmmeter to the $R \times 1000$ range.
2. Connect one of the ohmmeter test leads to the lead at the cathode (banded) end of the diode. Connect the other test lead to the other diode lead. Note the meter reading. Then interchange the meter leads and take another reading. One reading should be high and the other low (at least 10:1). If both readings are either high or low, the diode should be replaced.

TROUBLESHOOTING CHARTS

The following charts list the "Condition" and the "Possible Cause" or "Troubleshooting Procedure" of a large number of malfunctions. If a particular part or parts are mentioned (transistor Q112, for example, or switch SW7) as a possible cause, check these parts to see if they are wired or installed incorrectly. Also

check to see if an improper part was installed at that location. It is also possible, on rare occasions, for a part to be faulty.

NOTE: A synthesizer troubleshooting chart is located in the Illustration Booklet.

TRANSMITTER PROBLEMS

CONDITION	POSSIBLE CAUSE
No meter indication at TP101 (synthesizer locks okay).	<ol style="list-style-type: none"> 1. Q101. 2. L101 and L102 not adjusted properly.
No meter indication at TP102; TP101 okay.	<ol style="list-style-type: none"> 1. Q102. 2. L103 and L104 not adjusted properly.
No meter indication at TP103; TP102 okay.	<ol style="list-style-type: none"> 1. Q103. 2. L105 not adjusted properly.
No meter indication at TP104; TP103 okay.	<ol style="list-style-type: none"> 1. L106 and L107 not adjusted properly. 2. D101. 3. Cable shorted at P102.
No transmitter power output; TP104 okay and relay pulls in.	<ol style="list-style-type: none"> 1. Q301, Q302. 2. Trimmer capacitors C301, C302, C303, C305, C308, misadjusted.
Relay does not close when the microphone button is pressed.	<ol style="list-style-type: none"> 1. Microphone cable wired incorrectly. 2. Q409, Q413, Q414. 3. S301 wired wrong.
Relay closes when microphone button is pressed, but quickly drops back out.	<ol style="list-style-type: none"> 1. Synthesizer unlocking. 2. Outside band (jumper installed in synthesizer circuit board).
Relay is continuously energized.	<ol style="list-style-type: none"> 1. D407 shorted. 2. Q414 shorted.
Meter indicates output, dummy load remains cold. PA tuning is critical.	<ol style="list-style-type: none"> 1. Antenna socket not soldered on both sides of circuit board. 2. Relay K301 defective.
No voice or tone modulation; power output okay.	<ol style="list-style-type: none"> 1. Relay contacts. 2. Socket S301 wired wrong. 3. VD501.
No voice modulation; tone okay.	<ol style="list-style-type: none"> 1. IC101. 2. Microphone cable wired wrong or shorted. 3. Green shielded cable shorted.
No tone modulation; voice okay.	<ol style="list-style-type: none"> 1. IC102. 2. Switch SW2.

RECEIVER PROBLEMS

CONDITION	TROUBLESHOOTING PROCEDURE
<p>A. Squelch control inoperative. Audio output normal, Volume control action normal.</p>	<pre> graph TD START[START] --> Step1[Turn Squelch control fully clockwise. Voltage at positive (+) lead of C273 is at least 2 volts with no signal.] Step1 -- NO --> D202[D202, D203, Q209] Step1 -- YES --> Q206[Q206, Q210, Q211] </pre>
<p>B. No audio. S meter does not indicate a signal.</p>	<ol style="list-style-type: none"> 1. Q203, Q204. 2. IC203 or its socket installed wrong.
<p>C. No audio. S meter operates normally. Squelch control has no effect.</p>	<pre> graph TD START[START] --> Step1[Ground base of Q206. Squelch opens, giving normal audio.] Step1 -- NO --> Step2[1. Turn Volume to minimum. 2. Disconnect violet wire from pin H on receiver circuit board and connect a small wire from violet wire to pin 1 on IC406. 3. Advance Volume control. Loud tone is present.] Step1 -- YES --> Q210[Q210, Q211] Step2 -- YES --> IC202[IC202, Q205, Q206] Step2 -- NO --> IC203[IC203, speaker] </pre>
<p>D. Noise (with no signal input) is very low.</p>	<pre> graph TD START[START] --> Step1[10.245 MHz oscillator is operating.] Step1 -- NO --> Q208[Q208, Y205] Step1 -- YES --> Q201[Q201, Q203] </pre>
<p>E. Distorted audio.</p>	<ol style="list-style-type: none"> 1. L210 misadjusted. 2. Y201, Y202, Y203, Y204 in wrong locations.

SPECIFICATIONS

RECEIVER

Sensitivity	12 dB SINAD* (or 15 dB of quieting) at .5 μ V.
Squelch threshold	0.3 μ V or less.
Audio Output	1.5 watts at less than 10% THD; 2 watts maximum output (typical).
Image Rejection	-45 dB or greater.
Spurious Rejection	-50 dB or greater.
IF Rejection	-80 dB or greater.
Internally Generated Spurious Signals	Below 1 μ V equivalent (except at 146 and 148 MHz).
Bandwidth	6 dB at 15 kHz minimum and 60 dB at 30 kHz maximum.
Modulation Acceptance	7.5 kHz, minimum.

*SINAD =
$$\frac{\text{Signal} + \text{noise} + \text{distortion}}{\text{Noise} + \text{distortion}}$$

TRANSMITTER

Power Output	10 watts minimum to a 50 Ω load (13.8 VDC, 25°C).
Spurious and Harmonic Output	Spurious: -70 dB within 20 MHz of carrier; -50 dB elsewhere. Harmonic: -40 dB.
Modulation	FM, 0-7.5 kHz, adjustable.
Duty Cycle	100% with infinite VSWR.
Tone Encoder	3 tones, 70 to 200 Hz, approximately 700 Hz deviation.
Transmitter Offset	0 (simplex), -600 kHz, +600 kHz with crystals supplied. Provision for one other offset crystal.

GENERAL

Frequency Coverage	Any 2 MHz segment from 143.5 to 148.5 MHz. (Transmitter lockout can be defeated for out-of-band operation.)
Frequency Increments	5 kHz.
Frequency Stability	\pm .0015%.
Operating Temperature Range	15 to 125 degrees F (-10 to +50 degrees C).
Operating Voltage Range	12.6 to 16 VDC (13.8 VDC, nominal).
Current Consumption	Receive Mode: 700 mA maximum, squelched. Transmit Mode: 2.6 amperes maximum at 13.8 VDC.
Dimensions	2-3/4" high \times 8-1/4" \times 9-7/8" deep (7.1 \times 21 \times 24.5 cm).
Weight	2.25 lbs (2.83 kg).

The Heath Company reserves the right to discontinue products and to change specifications at any time without incurring any obligation to incorporate new features in products previously sold.

CIRCUIT DESCRIPTION

Refer to the Block Diagram (Illustration Booklet, Page 16) and the Schematic while you read this "Circuit Description." The part numbers are arranged in the following groups to help you locate specific parts on the Schematic, circuit boards, and chassis.

1-99	Parts mounted on the chassis.
100-199	Parts mounted on the transmitter circuit board.
200-299	Parts mounted on the receiver circuit board.
300-399	Parts mounted on the power amplifier circuit board.
400-499	Parts mounted on the synthesizer circuit board.
500-599	Parts mounted on the VCO circuit board.

The voltage controlled oscillator (VCO), which is the heart of this Transceiver, provides the proper frequencies for the transmitter and receiver injection. The VCO is part of a phase-locked loop, called a frequency synthesizer, which determines the frequency of the VCO and holds it as stable and accurate as a crystal-controlled oscillator. Three lever-operated binary-coded decimal switches and a 0/5

kHz miniature toggle switch select the receiver frequency you desire. A four position rotary switch allows you to select the transmitter offset frequency so that the transmitter automatically tracks the receiver. The frequency of the VCO is varied in step with the output of the transmitter audio stages (on the transmitter circuit board) to cause modulation.

The receiver mixes the incoming signal at the antenna with the sixth harmonic of the VCO signal. The resulting 10.7 MHz IF signal is filtered by an 8-pole crystal filter, amplified, and mixed with the output of a crystal-controlled oscillator to produce a 455 kHz IF signal. The transmitted audio is recovered from this IF signal by means of a quadrature detector. This audio signal is then amplified to a level sufficient to drive the speaker.

The transmitter multiplies the VCO output frequency by a factor of six and steps up the power to the level required to drive the power amplifier.

The power amplifier boosts the RF signal coming from the transmitter circuit board to provide a minimum of 10 watts of RF power, which is coupled to the antenna.

SYNTHESIZER

GENERAL

The synthesizer circuit board receives an 833.333 Hz reference signal from the transmitter circuit board and also the output signal from the voltage-controlled oscillator (VCO) on the VCO circuit board. The frequency of the signal coming from the VCO circuit board is one-sixth the desired transmitter frequency in the transmit modes, and is automatically switched in the receive mode so that, when multiplied by six, it provides a receiver injection signal that is 10.7 MHz below the receive frequency selected on the front panel switches.

The accuracy and stability of the VCO are proportional to the combined accuracy and stability of two temperature-compensated, crystal-controlled oscillators. One of these oscillators operates at 10 MHz and provides the 833.333 Hz reference signal. The other oscillator (offset oscillator) operates in the 20 MHz range. The VCO is phase-locked to these two oscillators. If the VCO becomes unlocked, the red "Synth Lock" LED will light. If this unlocked condition lasts for more than about one-half second, the transmitter is automatically disabled to prevent operation outside the band. This inhibit circuitry also disables the transmitter if the front panel switches are set below 144.000 MHz or above 147.995 MHz. This feature can be defeated if you desire to operate on MARS or CAP frequencies.

Transistor Q402 mixes the output of the offset oscillator (Q406) with the output of the VCO. A low-pass filter, consisting of C404 and L401 passes the difference signal to Q401 where it is shaped to be compatible to drive a programmable divider formed by IC401 through IC404. When the VCO is on the frequency that corresponds to that selected on the front panel switches, the output of the programmable divider is 833.333 Hz. If the VCO is not on the correct frequency, the output of the programmable divider is other than 833.333 Hz, which is required for lock.

IC406 compares the output frequency of the programmable divider to the 833.333 Hz reference. If they are equal, the tune voltage to the VCO remains unchanged and IC406 phase-locks the loop. If they are not equal, the phase-frequency detector, IC406, puts out pulses which are integrated (averaged) by loop filter Q404. This changes the tune voltage in the proper direction to tune the VCO toward the correct frequency and brings the output of the programmable divider toward 833.333 Hz (establishing the locked condition).

PROGRAMMABLE DIVIDER

The programmable divider, (see Figure 1) consists of IC401, IC402, IC403, and IC404. IC404, IC402, and IC403 are cascaded programmable, decade down-counters. The divisor, which is the number selected

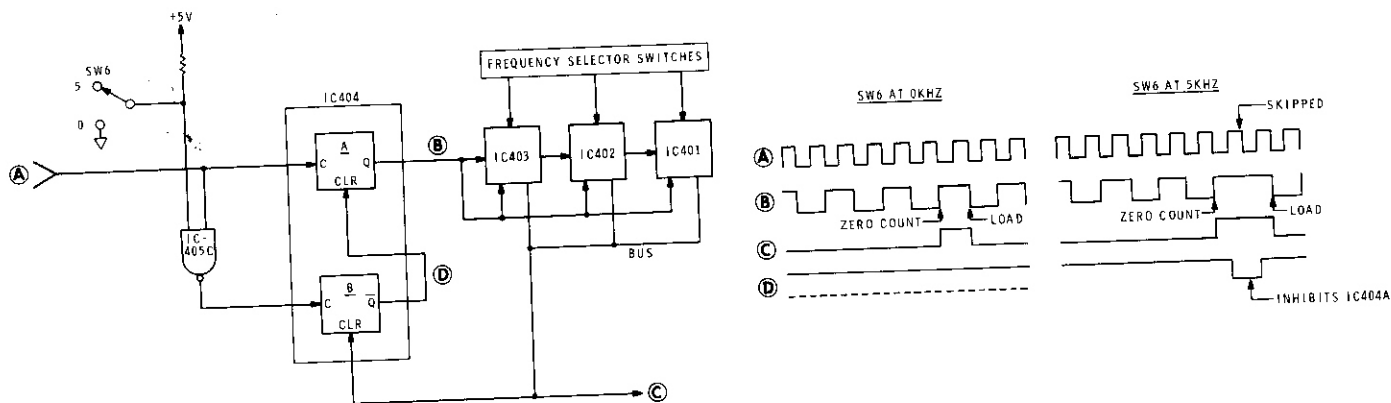

Figure 1



on the front panel switches, is "loaded" into the counters on the indicated negative edge, and each subsequent positive edge decrements this number by one. For example, if 6.94 (146.94 MHz) is selected, a 6 is loaded into IC401, a 9 into IC402, and a 4 into IC403. This makes the divisor 694. After 694 cycles have been counted, the "buss" line (common line between pins 12) goes high briefly. The resulting series of positive pulses on the bus line is the output of the programmable divider.

Flip-flop IC404A, just ahead of the cascaded counters, multiplies the total divisor by 2 which, in the example given, makes the total divisor $2 \times 694 = 1388$ (0/5 kHz switch is in the 0 kHz position). In the simplex (SIM) mode, the offset oscillator is operating at 23.333 MHz. If this is mixed with the required VCO frequency of 24.49 MHz (146.94 MHz/6), a difference frequency of 1.1567 MHz is obtained. If this difference is divided by 1388 (2×694), the result is 833.333 Hz, as required for lock.

If the 0/5 kHz switch is set to the 5 kHz position, the total divisor must increase by one to 1389 (2×694.5). This is accomplished by disabling IC404A during the cycle which just follows the positive edge of the buss output. In effect, IC404B counts the extra cycle and "hides" it from IC404A.

OFFSET OSCILLATOR

The offset oscillator is formed by Q406 and the associated circuitry. In the receive mode, the required oscillator frequency is 21.55 MHz. This crystal (Y405) is switched in by D406, which is turned on by Q412. Q412 conducts due to the 13.8 volts present on pin U via the relay coil.

In the transmit mode, the push-to-talk switch removes the base bias from Q413, which allows Q414 to turn on and energize the relay. Q411 and Q412 turn off and Q410 conducts, which switches in the appropriate transmitter offset crystal as selected by the front panel Mode switch, SW7.

OUT-OF-LOCK/BAND DETECTION AND TRANSMIT INHIBIT

Whenever the phase-locked loop is not locked, negative pulses will appear on one of the two inputs to IC405A. The active input is determined by whether

the output of the programmable divider is higher or lower than the 833.333 Hz reference. Positive pulses at the output of IC405A charge capacitor C421, which turns on Q405. When Q405 is turned on, it applies a low to pin 4 of IC405B, which causes its output to go high and turn on Q409. Q409 prevents Q414 from turning on when you press the PTT switch and thus inhibits the transmitter. The low on pin 4 of IC405B is also applied to Q407, which turns it off and allows Q408 to light the Synth Lock LED.

If the 1 MHz lever switch (SW3) is set to a number other than 4, 5, 6, or 7, the "4" output of the switch is grounded. This grounds pin 5 of IC405B and inhibits the transmitter as was described in the above paragraph. This helps prevent you from operating outside the 2-meter amateur band. (Out-of-band transmissions can still occur when the selected receive frequency is within the band, but the offset transmitter frequency is not.) If MARS or CAP operation is desired, you can remove the jumper on the synthesizer circuit board to disable the out-of-band inhibit feature.

R448, R449, and C443 briefly delay the inhibit circuitry to allow the synthesizer to lock on different frequencies in transmit and receive. The delay gives the loop a chance to lock when the Transceiver switches from receive to transmit. This transition typically takes less than 150 mS, but if the loop does not re-lock within approximately 500 mS, the transmitter inhibit circuitry releases the relay.

IC502, an ECL (emitter-coupled logic) integrated circuit, is the heart of the VCO. It is tuned by L501, C513, and varactor diode VD502. In the receive mode, Q502 switches in C509 and C511 which lower the frequency range by the required amount. In transmit, frequency modulation is accomplished by applying the transmitter audio to a second varactor diode, VD501. This assures constant deviation over the entire frequency range.

Q503 and Q504 make up a low-pass filter, which helps remove any residual 833.333 Hz reference from the tune voltage.

IC501, a separate 5-volt regulator, is included on the VCO circuit board. This regulator supplies only the oscillator IC and loop filter and thus helps to isolate the analog circuitry from the digital circuitry.

RECEIVER

The signal from the antenna passes through a double-tuned circuit to RF amplifier Q201. The output of Q201 is again double-tuned and then mixed by Q202 with the injection signal from Q207. This injection signal is 10.7 MHz below the selected receive frequency.

The 10.7 MHz IF output from Q202 passes through an 8-pole crystal bandpass filter to IF amplifier/limiter IC201. The output of this filter is mixed by Q203 with a 10.245 MHz signal from crystal oscillator Q208 and produces a 455 kHz IF signal.

The 455 kHz IF signal is amplified by Q204, which drives quadrature detector IC202. The output of Q204 is also rectified by D201 to produce an indication of relative signal strength on the S meter.

The recovered audio from IC202 passes through a filter, consisting of L211 and C237, which removes any remaining 455 kHz IF signal. The audio is preamplified by Q205 and then passes through the Volume control and a de-emphasis network to audio amplifier IC203, which drives the speaker.

The high frequency (noise) component of the audio signal passes through the Squelch control to squelch noise amplifier Q209. The amplified noise is then rectified by D202 and D203. When the resulting DC voltage is of a sufficient level, it will trigger the Schmitt trigger formed by Q210 and Q211. When triggered, the collector of Q211 is high and turns on Q206. This pulls the emitter of Q205 high, turning it off, and squelches the receiver. When the receiver is unsquelched, Q212 does not conduct, which allows Q213 to light the Channel Activity LED.

The audio output coming from IC203 is routed to the speaker through the PA circuit board where it is grounded in the transmit mode by a pair of relay contacts. SW301 selects either the internal speaker or an optional external 8-ohm speaker.

TRANSMITTER

MICROPHONE AMPLIFIER

The microphone audio passes through C128 to two cascaded amplifier stages in IC101. The values of R112 and C128 were chosen so any audio frequencies below 3 kHz are attenuated at a 6 dB-per-octave rate and thus provides pre-emphasis. Pre-emphasizing the audio at the transmitter and de-emphasizing it in the receiver results in a higher signal-to-noise ratio.

IC101B saturates on relatively low levels of speech and causes symmetrical clipping of the audio peaks. This limits the possible deviation for a given setting of the Deviation control. This type of limiting produces harmonics of the voice frequencies which must be eliminated. The network following the Deviation control is a post-limiter roll-off network which attenuates these higher frequencies.

TONE OSCILLATOR

The subaudible tones that are required to access some repeaters are generated by IC102 which is an astable multivibrator. Three separate tones may be set by multiturn controls R125, R126, and R127. Since the output of this IC is a square wave that contains many undesired harmonics, a roll-off network is also used here.

TRANSMITTER RF STAGES

The output signal from the VCO circuit board is coupled through a double-tuned circuit to tripler Q101. The output is again double-tuned and then doubled by Q102. The output of Q102 is amplified by Q103 to the level required to drive the PA.

Test points TP101, TP102, and TP103 provide a means of measuring the relative drive level to each stage. TP104 provides an indication of the output from the entire transmitter chain.

REFERENCE OSCILLATOR AND DIVIDERS

IC103A and IC103D together with Y101 form a stable 10 MHz oscillator whose output is buffered by IC103C. IC104, IC105, and IC106 divide the signal by 1000 and IC107 divides it by 12. The resulting 833.333 Hz is buffered by IC103B and provides the reference source for other circuits in the radio.

The network consisting of C146, C147, C148, and R139 provides a terminated, variable-signal source of 1 MHz harmonics for use as a receiver alignment aid if a signal generator is not available.

HASH FILTER/REGULATOR

The line coming from the power source is filtered by C151, L108, C152, and C153 to eliminate noise such as alternator whine and ignition noise.

D102 provides protection for the Transceiver against the reversed supply polarity, which causes D102 to conduct and blow the fuse. Q104 is a conventional series regulator that provides 11 volts. IC1 is a chassis-mounted, 5-volt regulator which supplies all the digital intergrated circuits in the transceiver.

POWER AMPLIFIER

C301, C302, and L301 (a printed circuit coil) match the input of the power amplifier circuit to the impedance of the signal coming from the transmitter.

C303, C304, C305, and L302 (another printed circuit coil) provide matched interstage coupling between Q301 and Q302.

L303, C308, and C309 match the impedance of the output of Q302 to the 50 Ω antenna output. C311, C312, C313, L304, and L305 form a low-pass filter for the output circuit of Q302.

The output signal is routed through relay K301 to the antenna socket on the rear panel of the Transceiver.

D301 rectifies a sample of the RF output so the S meter can provide an indication of relative power output.

CIRCUIT BOARD X-RAY VIEWS

NOTE: To find the PART NUMBER of a component for the purpose of ordering a replacement part:

- A. Find the circuit component number (R5, C3, etc.) on the X-Ray View.
- B. Locate this same number in the "Circuit Component Number" column of the "Parts List."
- C. Adjacent to the circuit component number, you will find the PART NUMBER and DESCRIPTION which must be supplied when you order a replacement part.

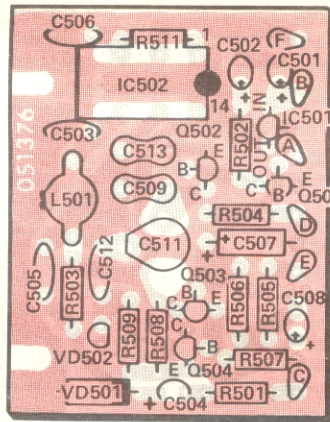

VCO CIRCUIT BOARD
 (Shown from component side.
 Foil on component side is shown in red.)

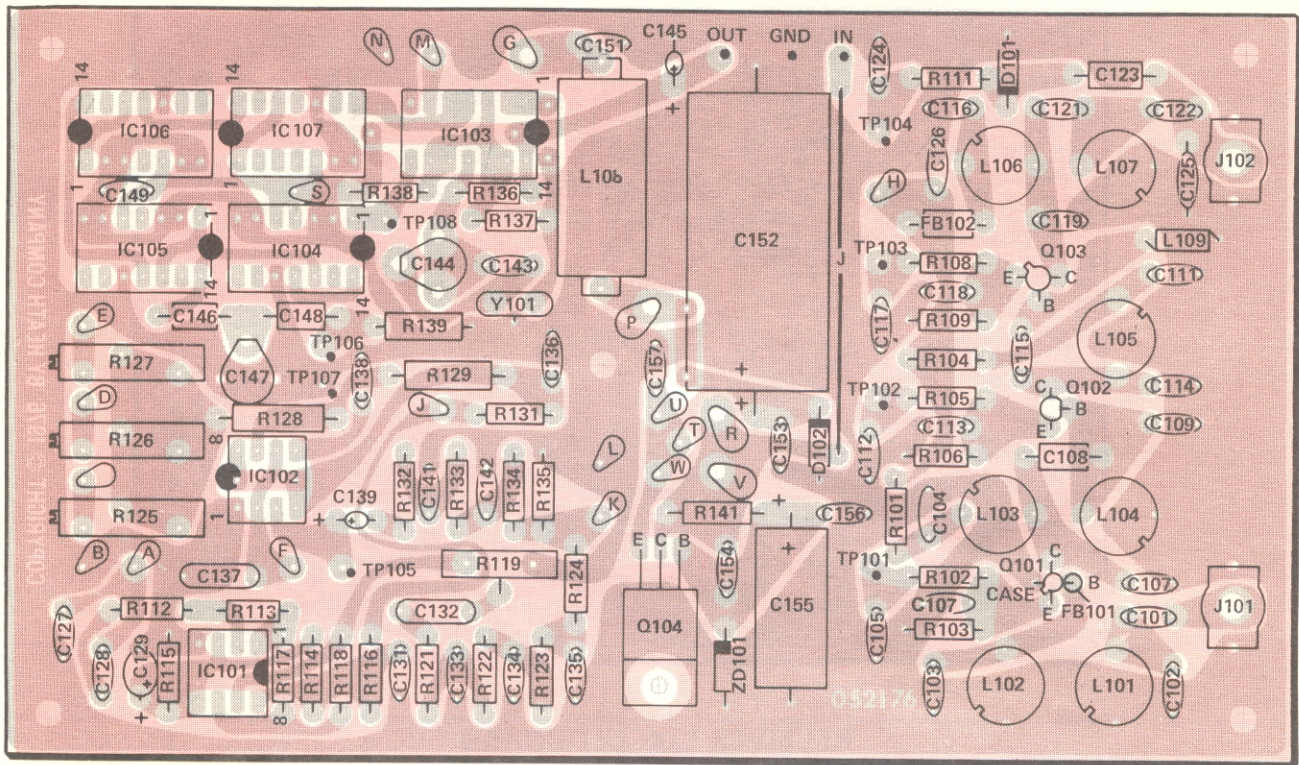

TRANSMITTER CIRCUIT BOARD
 (Shown from component side.)
 Foil on component side is shown in red.)

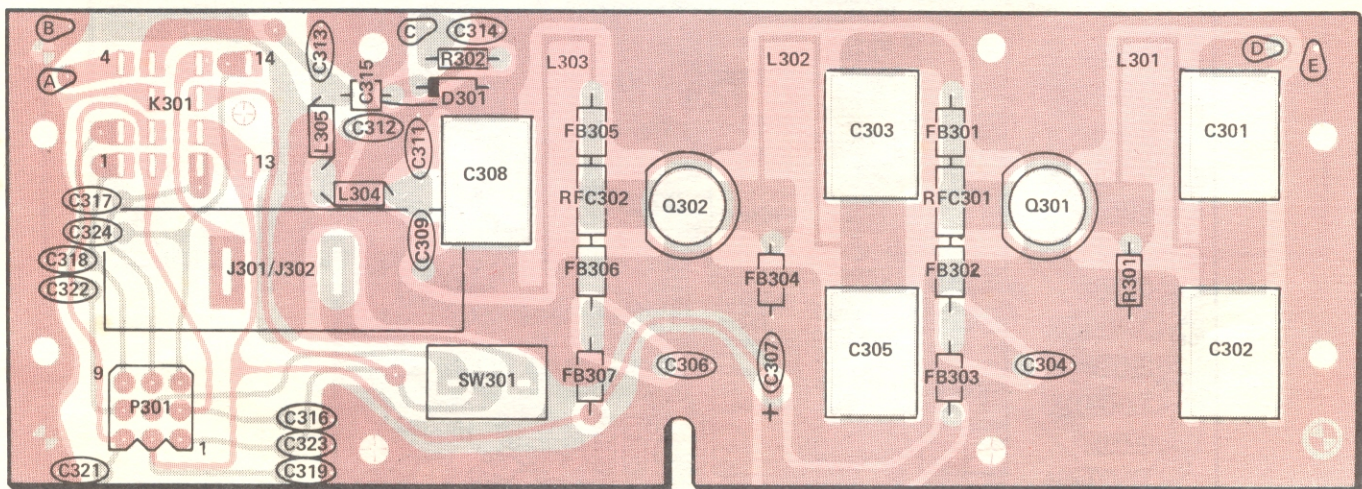

POWER AMPLIFIER CIRCUIT BOARD
 (Shown from component side.)
 Foil on component side is shown in red.)

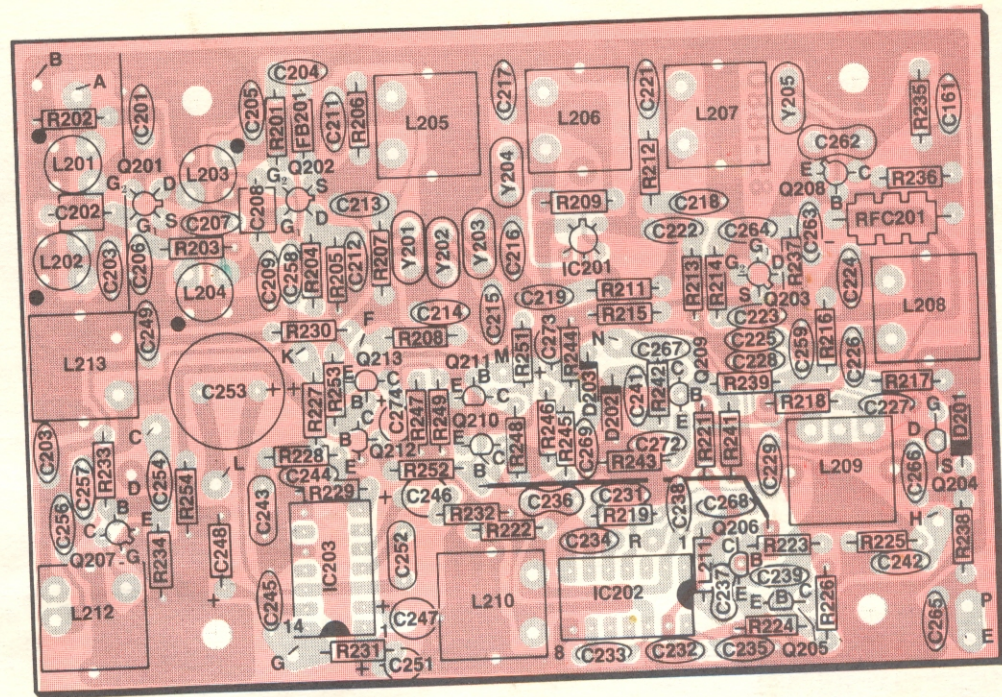

RECEIVER CIRCUIT BOARD
 (Shown from component side.
 Foil on component side is shown in red.)

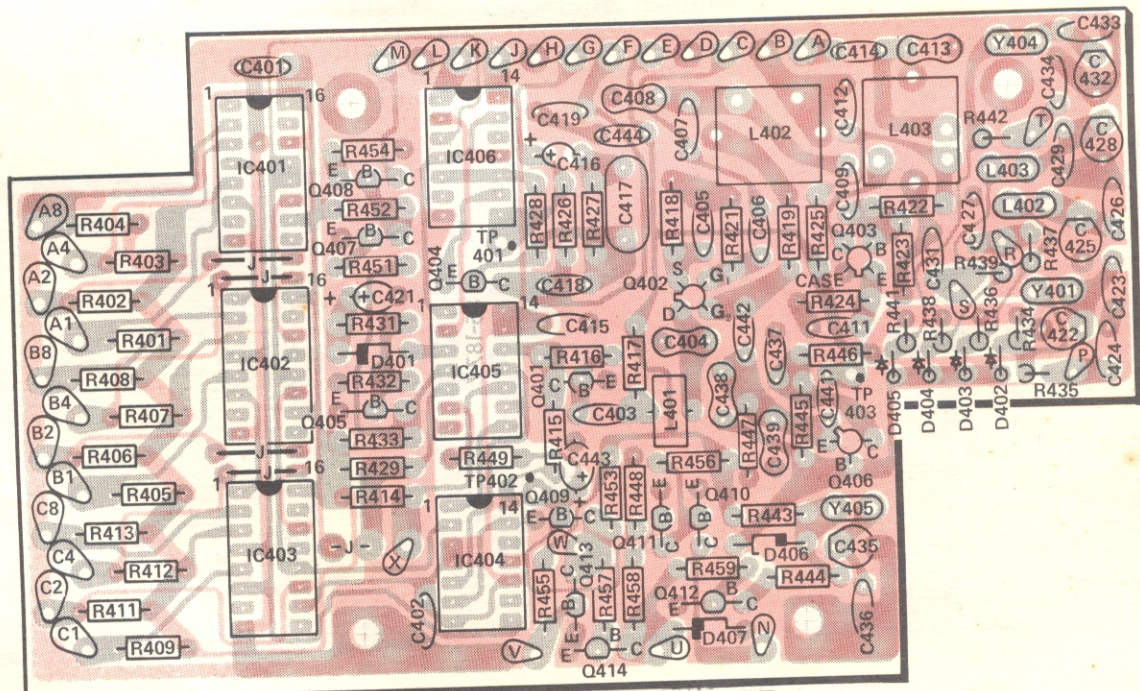

SYNTHESIZER CIRCUIT BOARD
 (Shown from component side.
 Foil on component side is shown in red.)

IDENTIFICATION CHARTS

DIODES

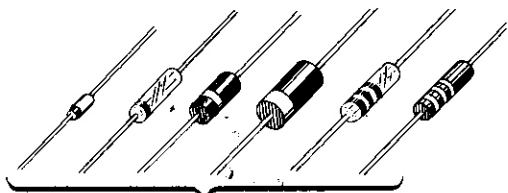
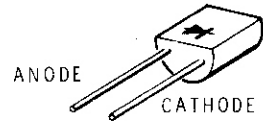

HEATH PART NUMBER	MAY BE REPLACED WITH	CIRCUIT COMPONENT NUMBER	IDENTIFICATION
56-24	1N458	D402, D403, D404, D405, D406	<p>NOTE: HEATH PART NUMBERS ARE STAMPED ON MOST DIODES.</p>  <p>BANDED END</p>
56-26	1N191	D202, D203	
56-56	1N4149	D101, D201, D301, D401	
56-57	1N716A	ZD101	
56-77	FV1010	VD501	
57-27	1N2071	D102	
57-65.	1N4002	D407	
56-642	MV2107	VD502	 <p>ANODE CATHODE</p>

TRANSISTORS

HEATH PART NUMBER	MAY BE REPLACED WITH	CIRCUIT COMPONENT NUMBER	BASING DIAGRAM	
417-134	MPS6520	Q502	E	
417-154	2N2369	Q208, Q414	A	
417-169	MPF105	Q204	B	
417-175	2N5294	Q104	C	
417-205	2N3866	Q103	A	
417-240	40673	Q402	G	
417-290	MRF502	Q101, Q207, Q403	D	
417-293	2N5770	Q102	E	
417-801	MPSA20	Q205, Q206, Q209, Q210, Q211, Q212, Q213, Q401, Q404, Q405, Q407, Q408, Q409, Q410, Q411, Q412, Q413, Q501, Q503	E	
417-803	2N6081 OR B12-12	Q302	F	
417-804	2N6080 OR B3-12	Q301	F	
417-863	MFE131	Q201, Q202, Q203	G	
417-865	MPSA55	Q504	E	

*THE COLLECTOR LEAD IS CUT ON AN ANGLE.

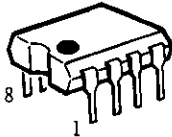
INTEGRATED CIRCUITS

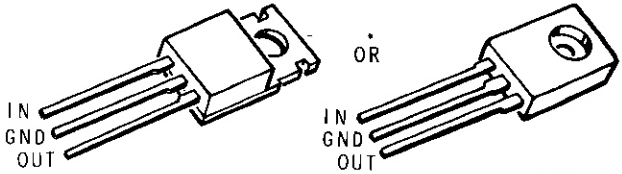
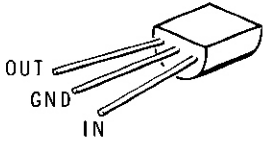
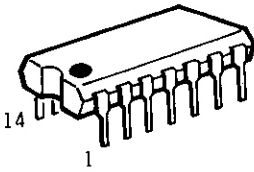
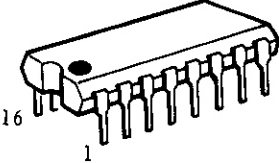
HEATH PART NUMBER	MAY BE REPLACED WITH	CIRCUIT COMPONENT NUMBER	IDENTIFICATION	
442-21	MC1458 OR NE5558V	IC101		
442-53	NE555V	IC102		
442-20	UA703	IC201		
442-54	UA7805	IC1		
442-627	78L05	IC501		
442-28	MC1357P	IC202		
442-610	TBA820	IC203		
443-1	SN7400N	IC107, IC405		
443-5	SN7473N	IC404		
443-7	SN7490N	IC104, IC105, IC106		
443-34	SN7492N	IC103		
443-62	MC4044P	IC406		
443-740	MC1648P	IC502		
443-61	MC4016P	IC401, IC402, IC403		

FOR PARTS REQUESTS ONLY

- Be sure to follow instructions carefully.
- Use a separate letter for all correspondence.
- Please allow 10 - 14 days for mail delivery time.

DO NOT WRITE IN THIS SPACE

INSTRUCTIONS

- Please print all information requested.
- Be sure you list the correct **HEATH** part number exactly as it appears in the parts list.
- If you wish to prepay your order, mail this card and your payment in an envelope. Be sure to include 10% (25¢ minimum, \$3.50 maximum) for insurance, shipping and handling. Michigan residents add 4% tax.
Total enclosed \$ _____
- If you prefer COD shipment, check the COD box and mail this card. COD

NAME _____
 ADDRESS _____
 CITY _____
 STATE _____ ZIP _____

The information requested in the next two lines is not required when purchasing nonwarranty replacement parts, but it can help us provide you with better products in the future.

Model # _____ Invoice # _____
 Date Purchased _____ Location Purchased _____

LIST HEATH PART NUMBER	QTY.	PRICE EACH	TOTAL PRICE

TOTAL FOR PARTS	
HANDLING AND SHIPPING	
MICHIGAN RESIDENTS ADD 4% TAX	
TOTAL AMOUNT OF ORDER	

SEND TO: **HEATH COMPANY**
 BENTON HARBOR
 MICHIGAN 49022
ATTN: PARTS REPLACEMENT

Phone (Replacement parts only): 616 982-3571

FOR PARTS REQUESTS ONLY

- Be sure to follow instructions carefully.
- Use a separate letter for all correspondence.
- Please allow 10 - 14 days for mail delivery time.

DO NOT WRITE IN THIS SPACE

INSTRUCTIONS

- Please print all information requested.
- Be sure you list the correct **HEATH** part number exactly as it appears in the parts list.
- If you wish to prepay your order, mail this card and your payment in an envelope. Be sure to include 10% (25¢ minimum, \$3.50 maximum) for insurance, shipping and handling. Michigan residents add 4% tax.
Total enclosed \$ _____
- If you prefer COD shipment, check the COD box and mail this card. COD

NAME _____
 ADDRESS _____
 CITY _____
 STATE _____ ZIP _____

The information requested in the next two lines is not required when purchasing nonwarranty replacement parts, but it can help us provide you with better products in the future.

Model # _____ Invoice # _____
 Date Purchased _____ Location Purchased _____

LIST HEATH PART NUMBER	QTY.	PRICE EACH	TOTAL PRICE

TOTAL FOR PARTS	
HANDLING AND SHIPPING	
MICHIGAN RESIDENTS ADD 4% TAX	
TOTAL AMOUNT OF ORDER	

SEND TO: **HEATH COMPANY**
 BENTON HARBOR
 MICHIGAN 49022
ATTN: PARTS REPLACEMENT

Phone (Replacement parts only): 616 982-3571

CUT ALONG DOTTED LINE

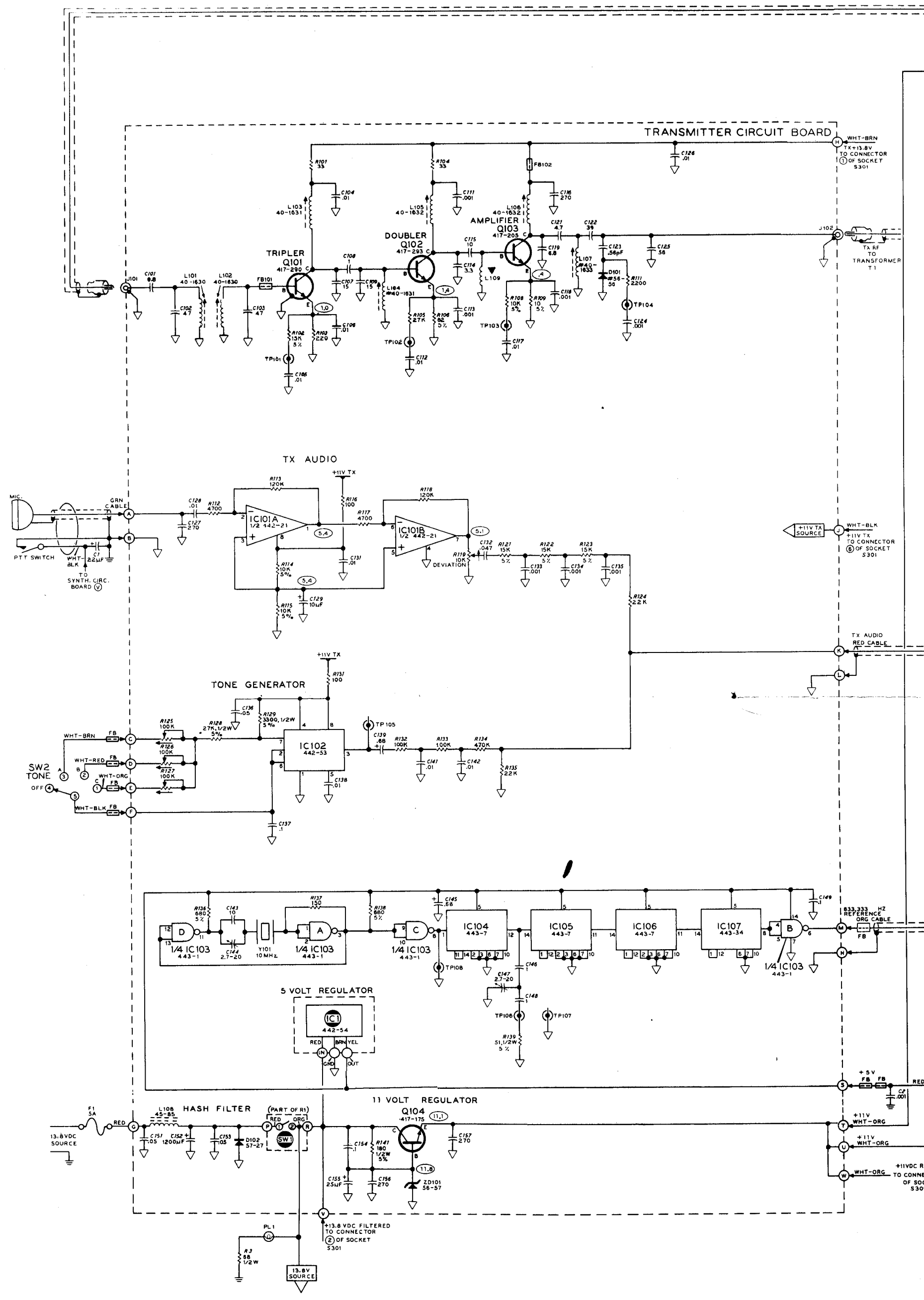

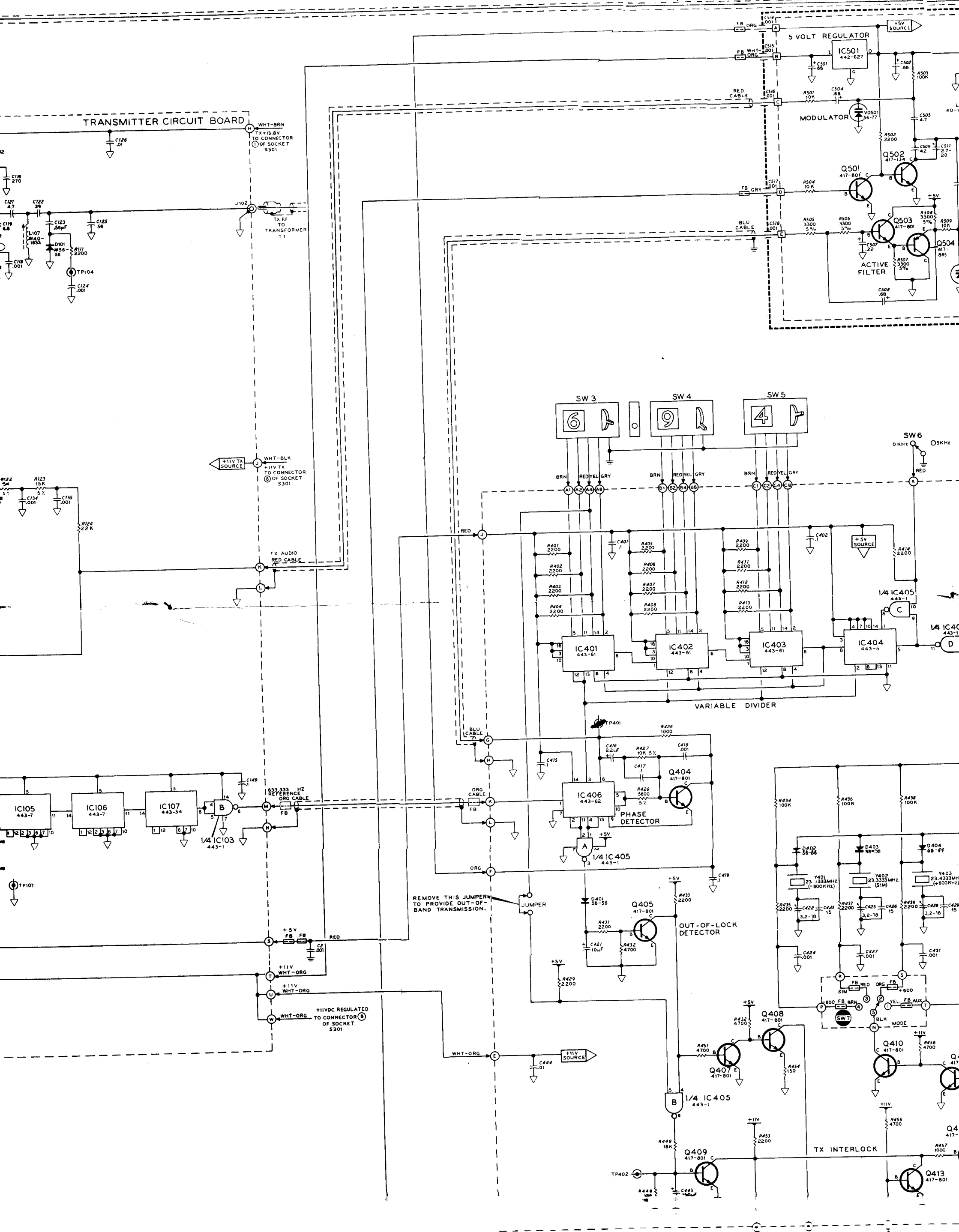

TRANSMITTER CIRCUIT BOARD

5 VOLT REGULATOR

MODULATOR

ACTIVE FILTER

SW 3

SW 4

SW 5

SW 6

VARIABLE DIVIDER

PHASE DETECTOR

OUT-OF-LOCK DETECTOR

TX INTERLOCK

REMOVE THIS JUMPER TO PROVIDE OUT-OF-BAND TRANSMISSION.

+11V TX SOURCE
WHT-BLK TO CONNECTOR ① OF SOCKET S301

TX AUDIO
RED CABLE

+5V FB
WHT-ORG

+11V WHT-ORG

+11V WHT-ORG

+11VDC REGULATED TO CONNECTOR ② OF SOCKET S301

+11V SOURCE

+5V

+11V

+11V

+11V

+11V

+11V

+11V

+11V

+11V

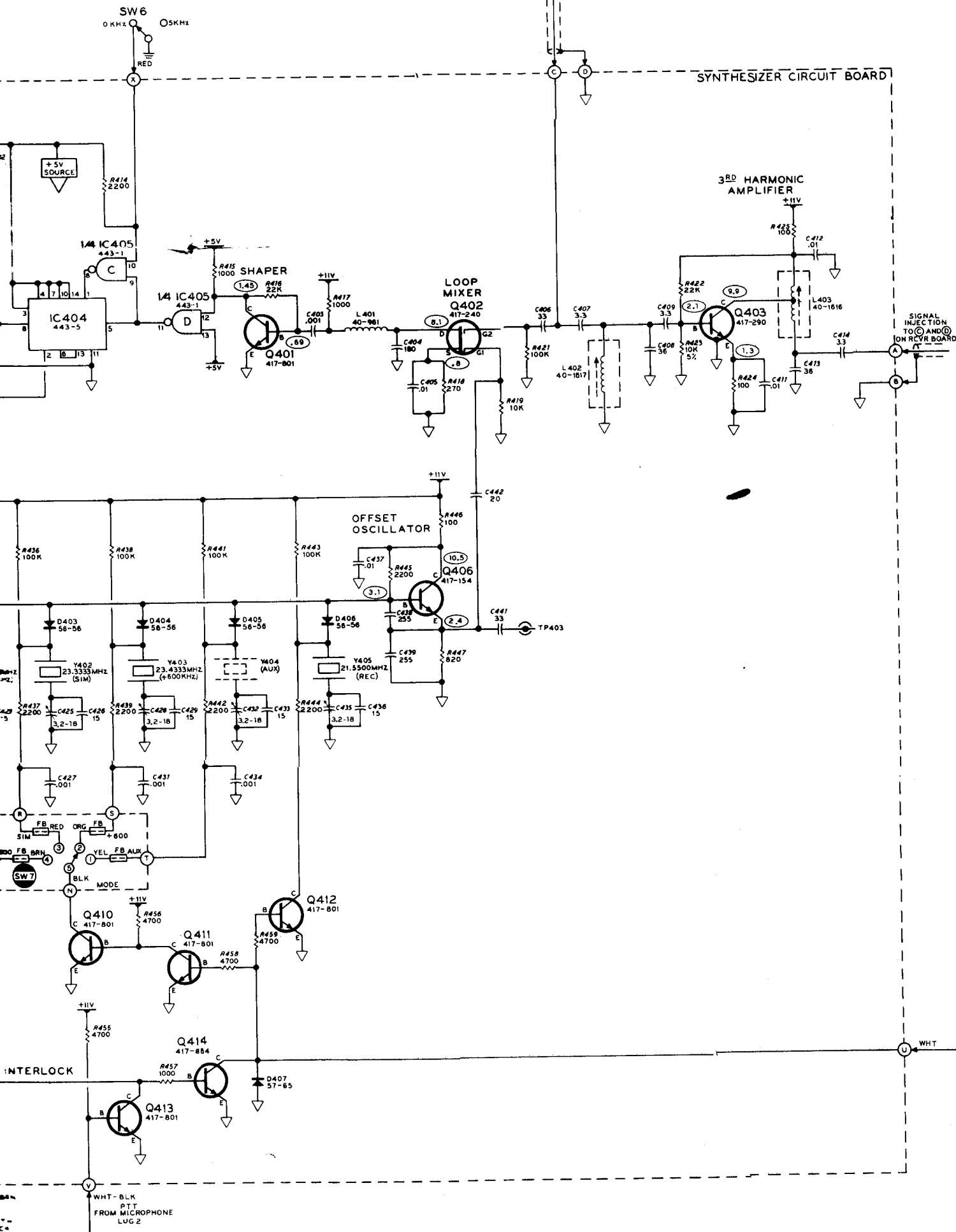
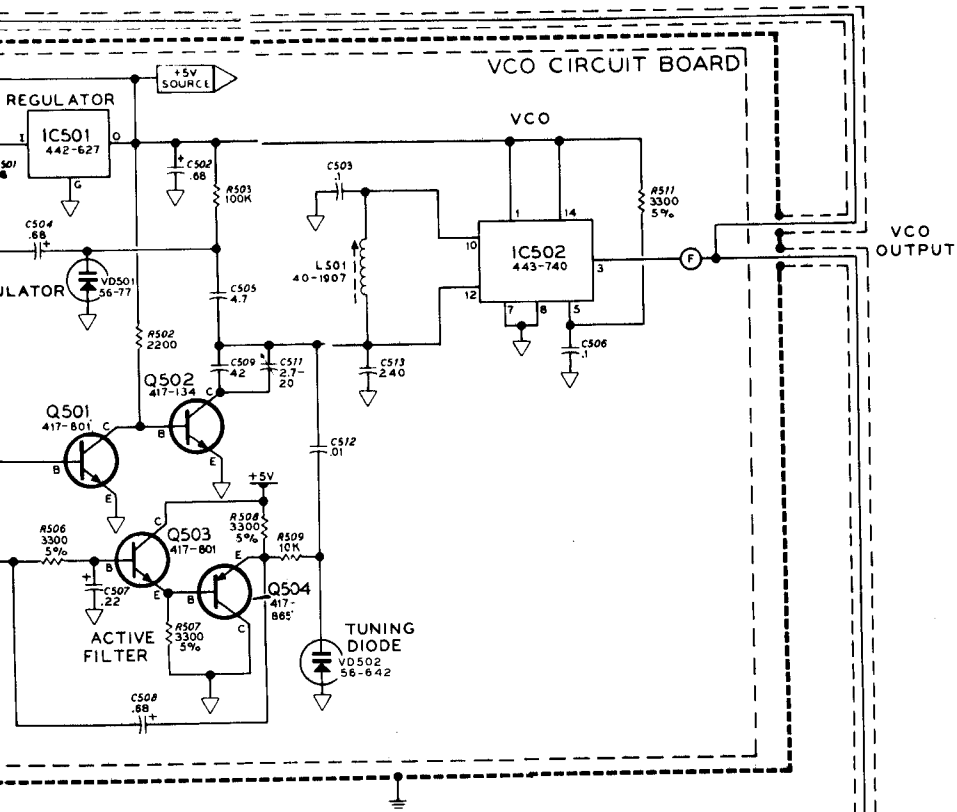

SYNTHESIZER

NOTES:

1. COMPONENTS LISTED IN THE COMP. LIST
2. ALL RESISTORS ARE 1% TOLERANCE UNLESS OTHERWISE NOTED. M=1.00
3. CAPACITORS ARE 5% TOLERANCE UNLESS OTHERWISE NOTED.
4. ARROW POINTERS INDICATE VIEWED DIRECTIONS.
5. CIRCLES WITH NUMBERS 1-11 INDICATE TEST POINTS.
6. INVERTED TRIANGLE POINTERS INDICATE TEST POINTS.
7. TRIANGLE POINTERS INDICATE TEST POINTS.
8. SQUARE POINTERS INDICATE TEST POINTS.
9. TRIANGLE POINTERS WITH A BAR INDICATE TEST POINTS.
10. RECTANGLE POINTERS INDICATE TEST POINTS.
11. CIRCLE WITH A TRIANGLE POINTERS INDICATE TEST POINTS.

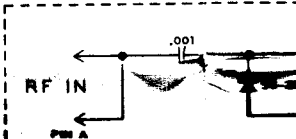

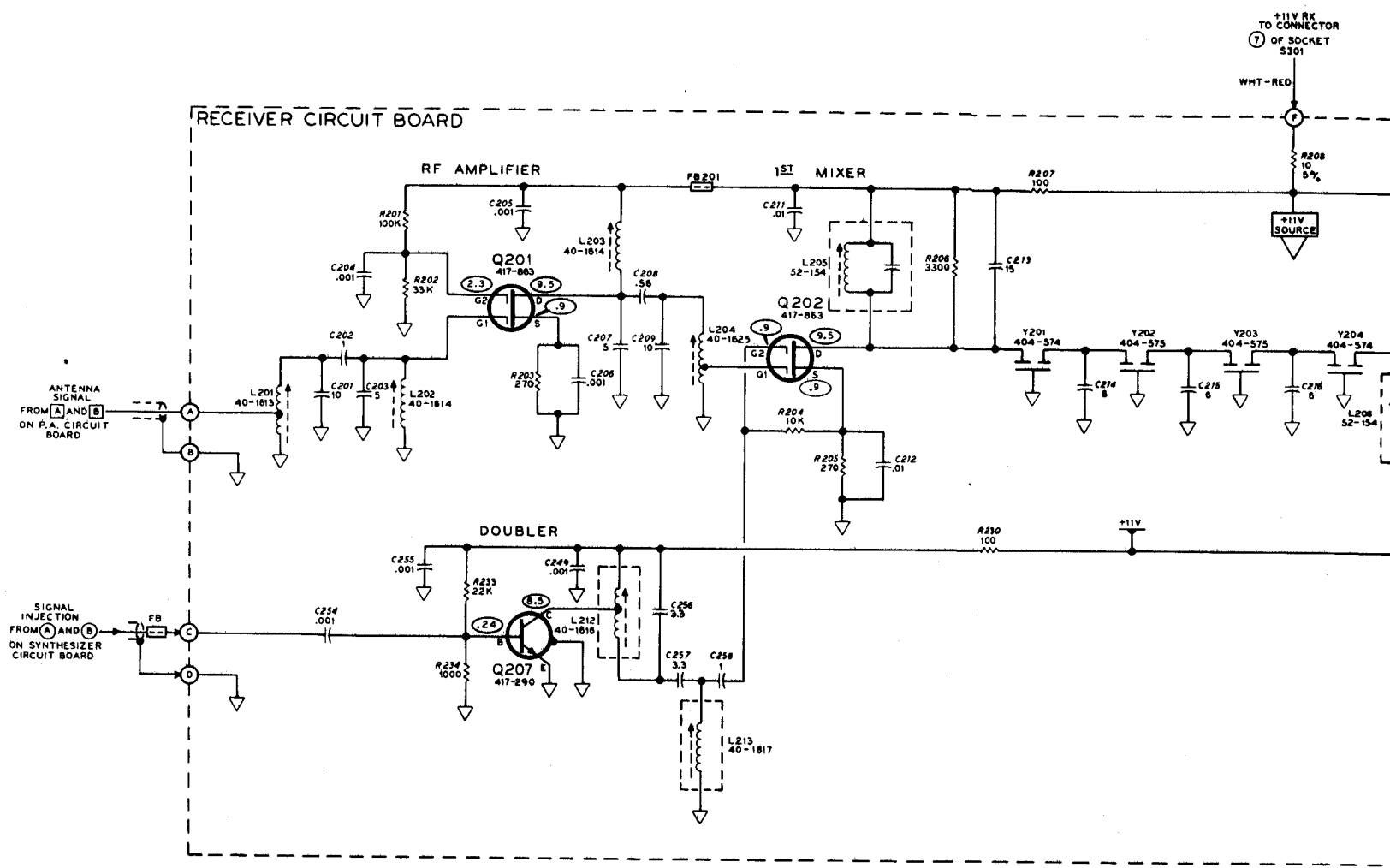
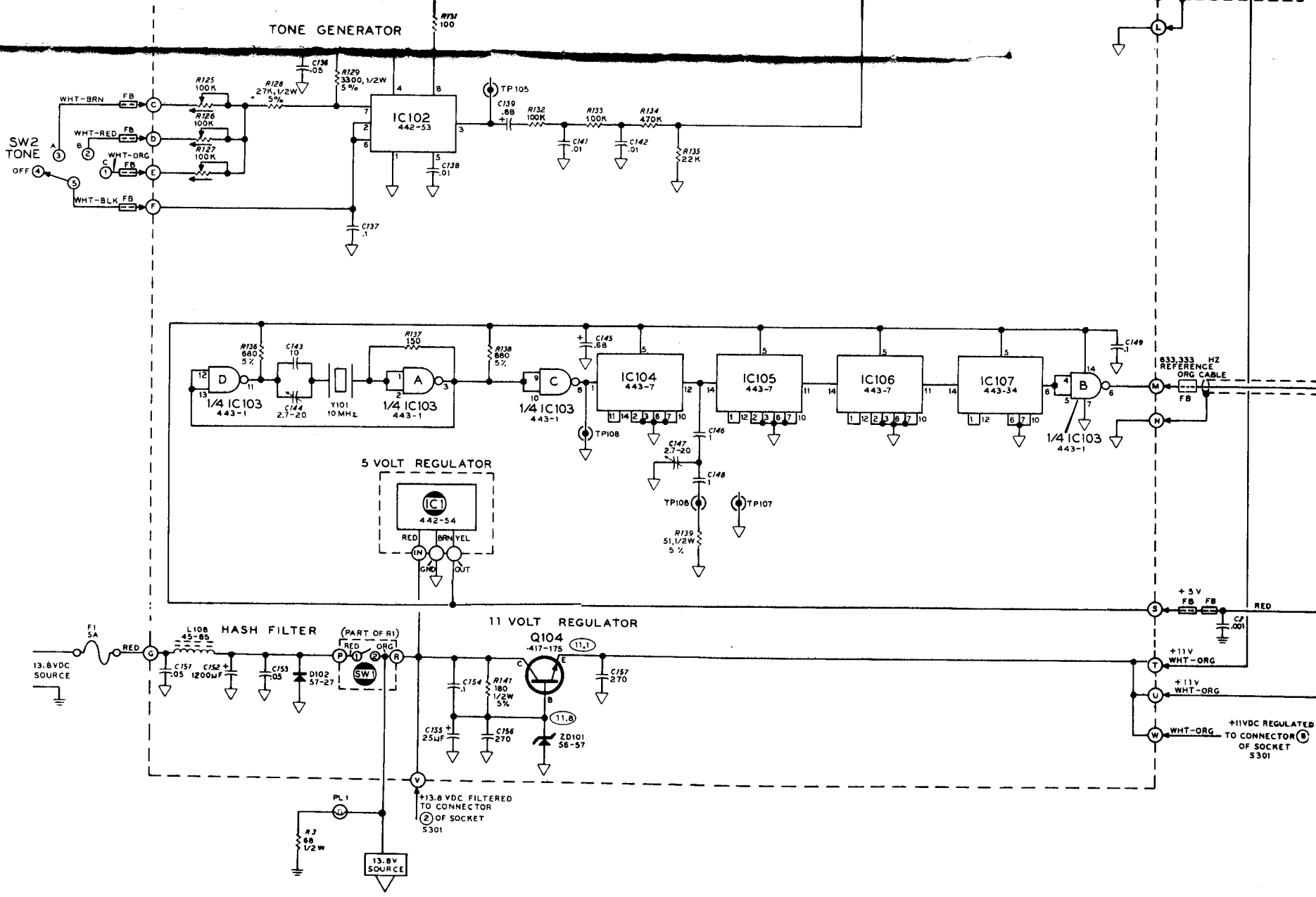

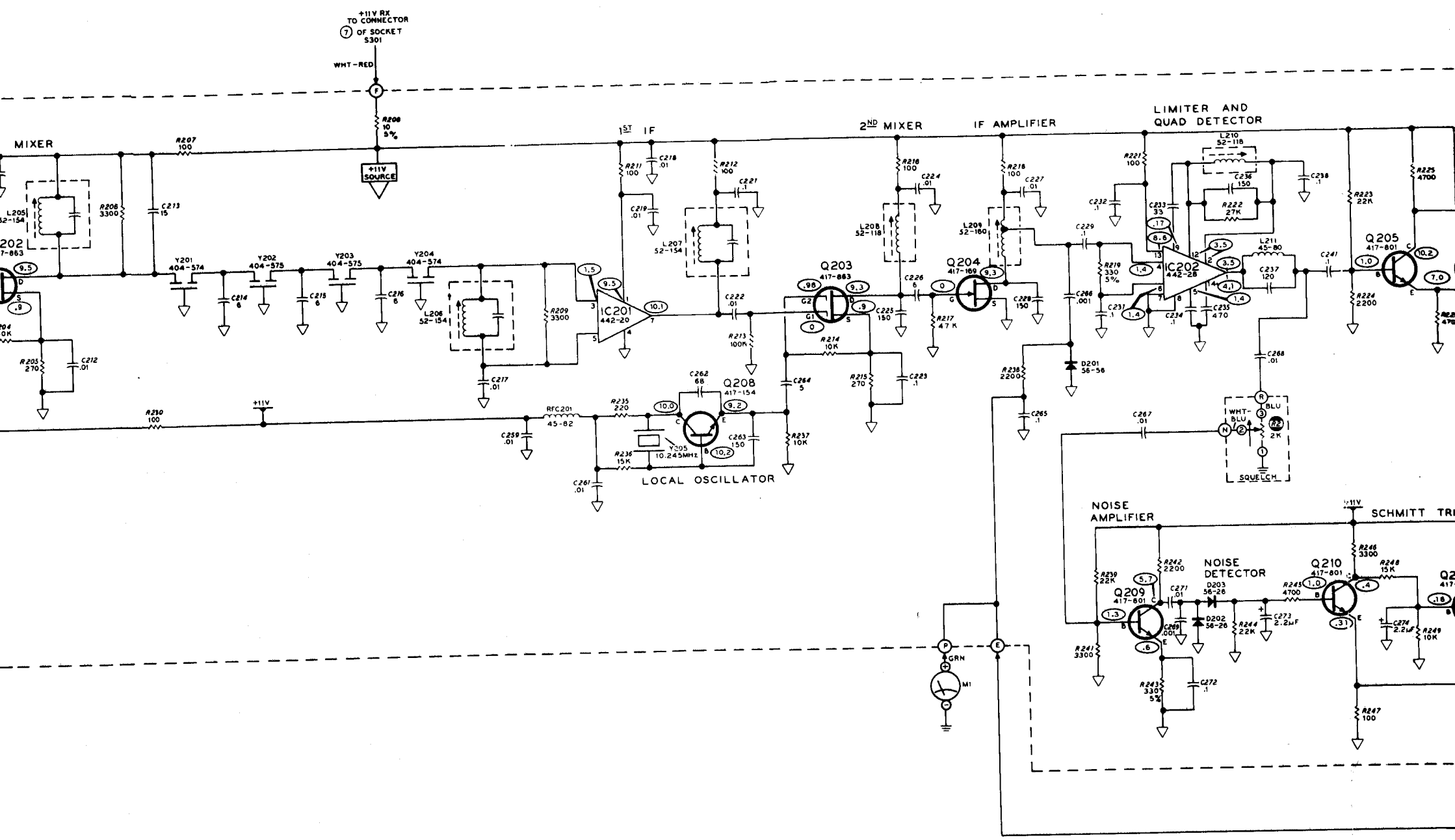
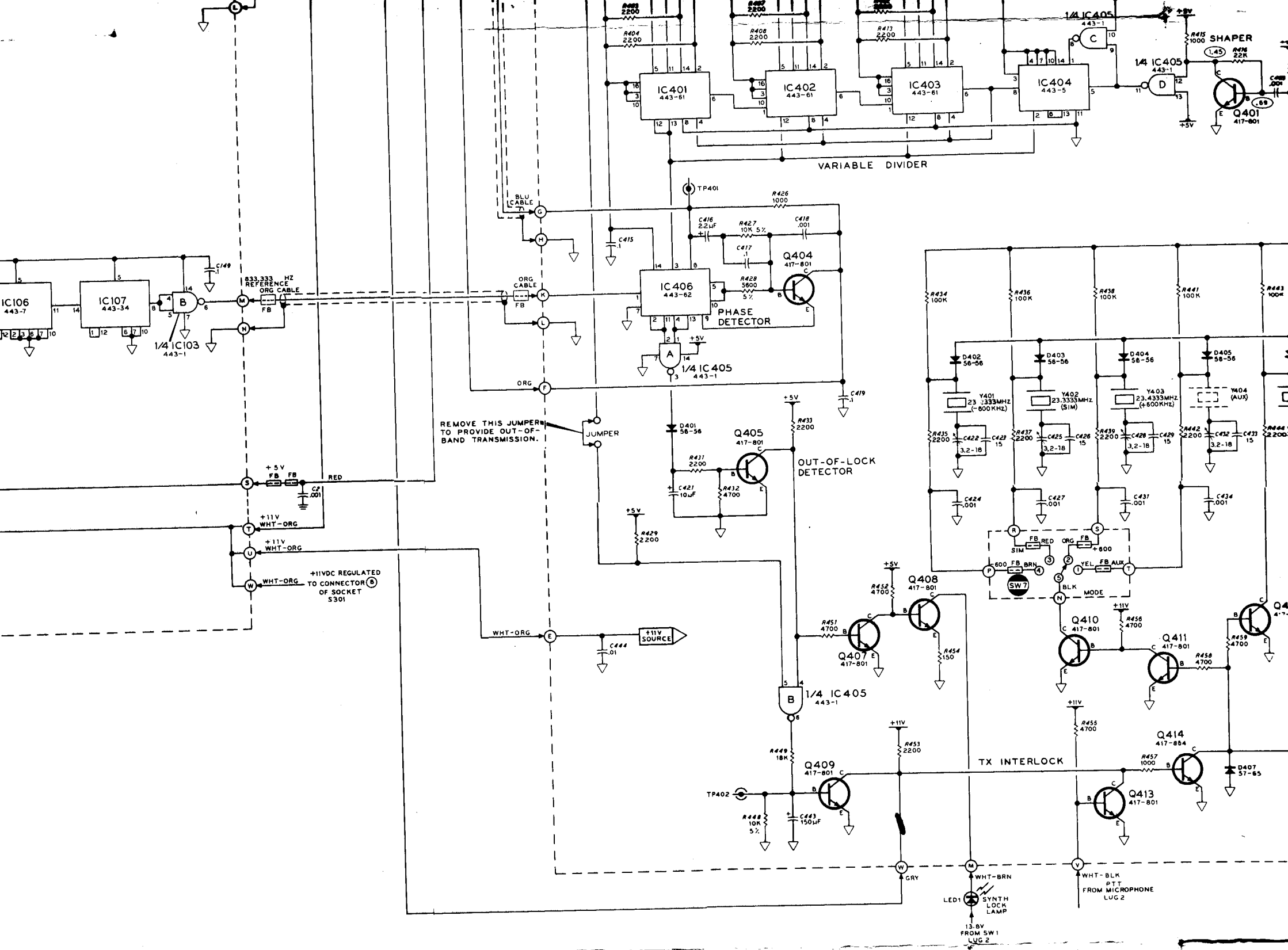

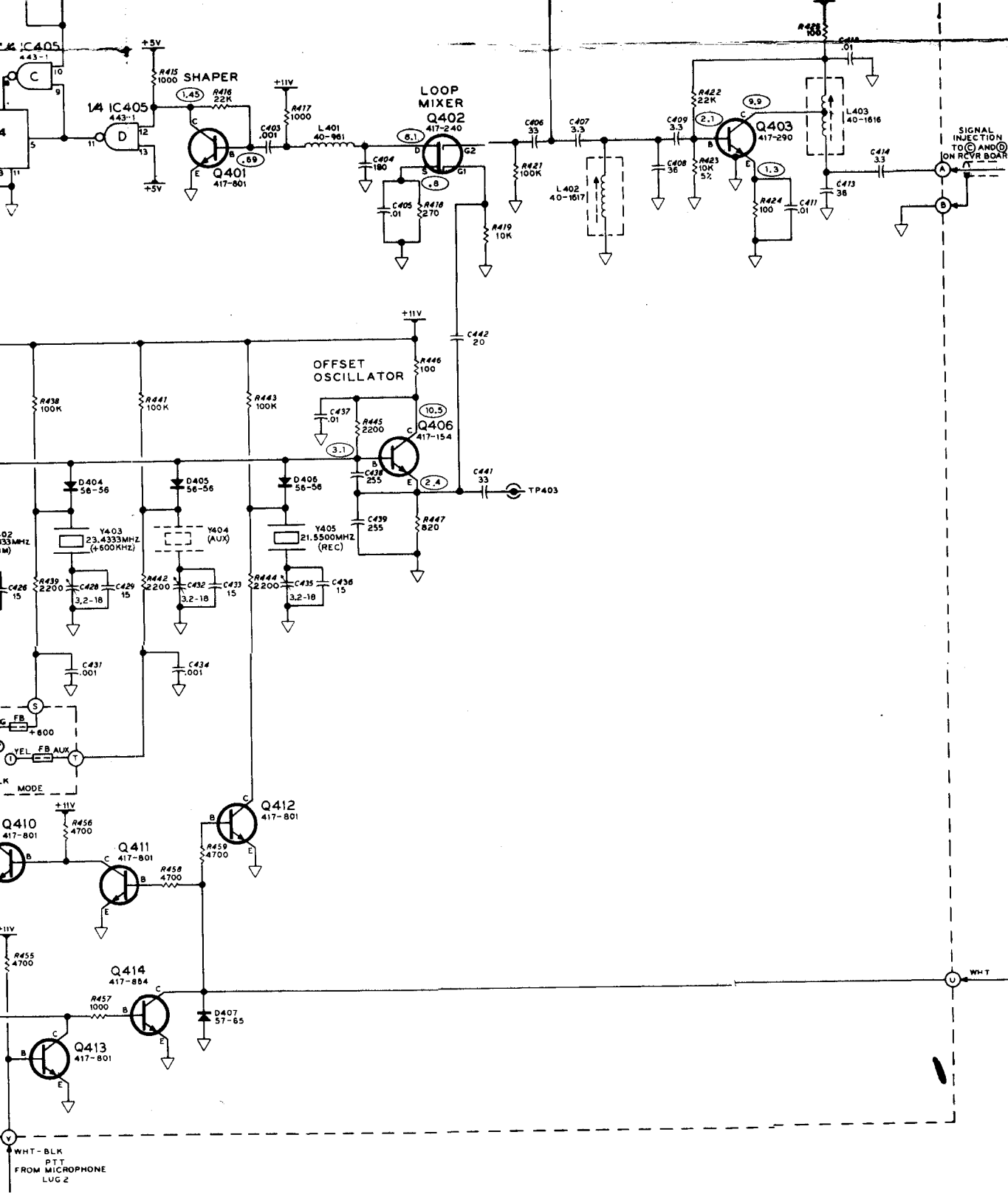



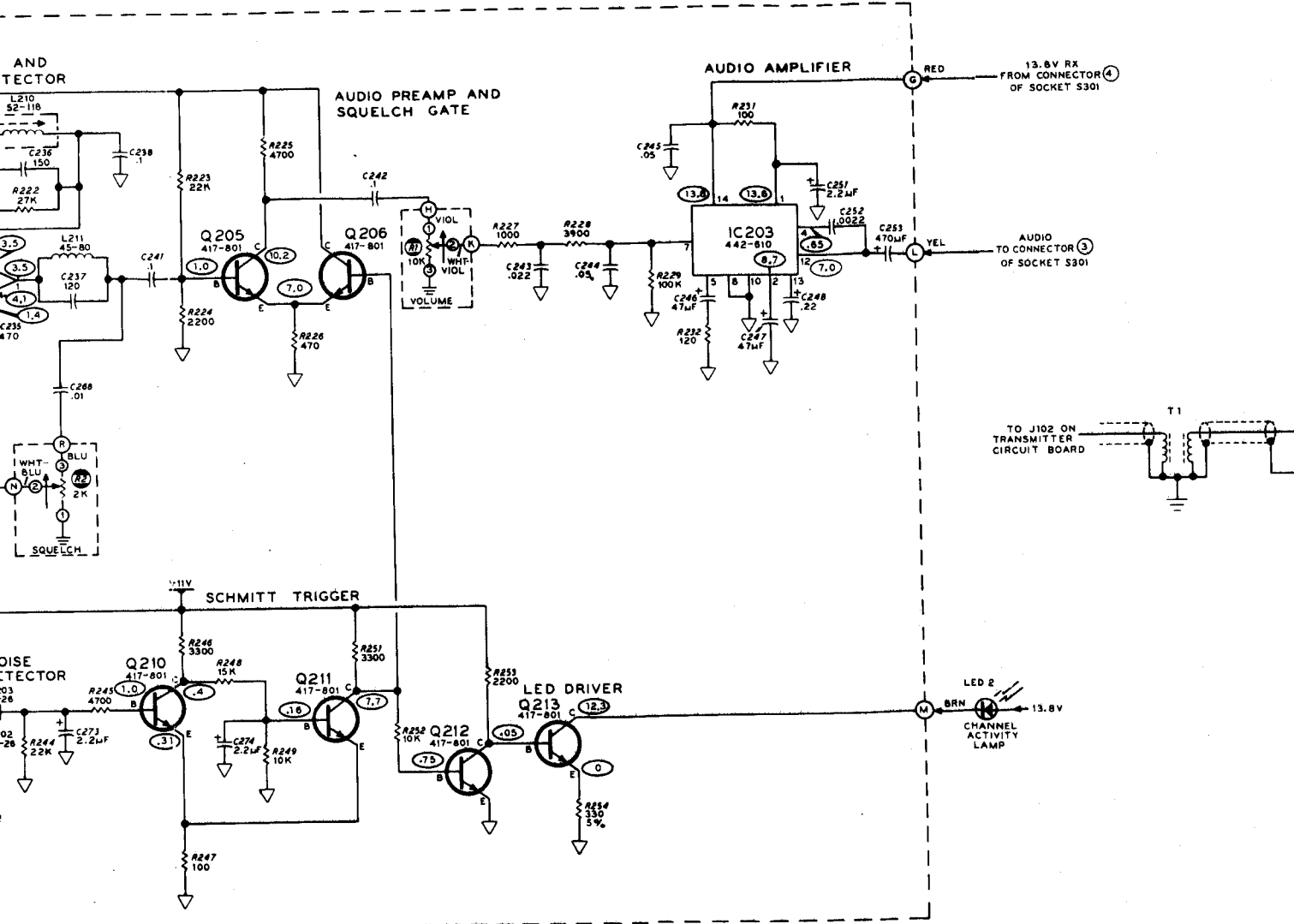
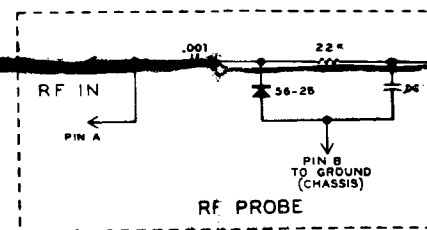



- COMPONENT NUMBER
- 1-99 PARTS MO
 - 100-199 PARTS MO
 - 200-299 PARTS MO
 - 300-399 PARTS MO
 - 400-499 PARTS MO
 - 500-599 PARTS MO
2. ALL RESISTORS ARE OTHERWISE NOTED. M=1,000,000.
 3. CAPACITORS LESS OTHER CAPACITORS NOTED.
 4. ARROWS AT CONTR VIEWED FROM THE
 5. ○ THIS SYMBOL MEASURED IN THE POINT IN THE FOLLOWING C
 1. NO SIGN
 2. RECEIVER
 3. VOLUME
 4. TRANSMI
 6. ▽ THIS SYMBOL
 7. ≡ THIS SYMBOL
 8. □ THIS SYMBOL CIRCUIT BOA
 9. ▴ THIS SYMBOL BUILDER.
 10. REFER TO THE PHYSICAL LO
 11. ⊙ THIS SYMBOL



NOTES

COMPONENT NUMBERS ARE IN THE FOLLOWING GROUPS.

- 1-99 PARTS MOUNTED ON THE CHASSIS.
 - 100-199 PARTS MOUNTED ON THE TRANSMITTER CIRCUIT BOARD.
 - 200-299 PARTS MOUNTED ON THE RECEIVER CIRCUIT BOARD.
 - 300-399 PARTS MOUNTED ON THE POWER AMPLIFIER CIRCUIT BOARD.
 - 400-499 PARTS MOUNTED ON THE SYNTHESIZER CIRCUIT BOARD.
 - 500-599 PARTS MOUNTED ON THE VCO CIRCUIT BOARD.
2. ALL RESISTORS ARE 1/4-WATT, 10% TOLERANCE, UNLESS OTHERWISE NOTED. RESISTOR VALUES ARE IN OHMS; k=1000, M=1,000,000.
 3. CAPACITORS LESS THAN 1 ARE IN μ F (MICROFARADS). ALL OTHER CAPACITORS ARE IN pF (PICOFARADS) UNLESS OTHERWISE NOTED.
 4. ARROWS AT CONTROLS INDICATE CLOCKWISE ROTATION AS VIEWED FROM THE SHAFT END OF THE CONTROL.
 5.  THIS SYMBOL INDICATES A POSITIVE DC VOLTAGE MEASURED WITH A HIGH IMPEDANCE VOLTMETER FROM THE POINT INDICATED TO CHASSIS GROUND UNDER THE FOLLOWING CONDITIONS:
 1. NO SIGNAL INPUT.
 2. RECEIVER SQUELCHED AT THRESHOLD.
 3. VOLUME CONTROL FULLY COUNTERCLOCKWISE.
 4. TRANSMITTER VOLTAGES: KEYED WITHOUT MODULATION.
 6.  THIS SYMBOL INDICATES CIRCUIT BOARD GROUND.
 7.  THIS SYMBOL INDICATES CHASSIS GROUND.
 8.  THIS SYMBOL INDICATES A SOLDERED CONNECTION TO A CIRCUIT BOARD.
 9.  THIS SYMBOL INDICATES A COIL WOUND BY THE KIT BUILDER.
 10. REFER TO THE "CIRCUIT BOARD X-RAY VIEWS" FOR THE PHYSICAL LOCATION OF PARTS.
 11.  THIS SYMBOL INDICATES A TEST POINT.

Copyright © 1976
 Heath Company
 All Rights Reserved
 Printed in the United States of America

