



**WILCOXSON**

**Electronic equipment**

OPERATING MANUAL  
VIKING VALIANT  
TRANSMITTER

## STANDARD WARRANTY

Adopted and Recommended by the

Radio - Electronics - Television Manufacturers Association

The E. F. Johnson Company warrants each new radio product manufactured by it to be free from defective material and workmanship and agrees to remedy any such defect or to furnish a new part, except for electron tubes, in exchange for any part of any unit of its manufacture which under normal installation, use and service disclosed such defect, provided the unit is delivered by the owner to us or to our authorized radio dealer or wholesaler from whom purchased, intact, for our examination, with all transportation charges prepaid to our factory, within ninety days from the date of sale to original purchaser and provided that such examination disclosed, in our judgement, that it is thus defective.

This warranty does not extend to any of our radio products which have been subjected to misuse, neglect, accident, incorrect wiring not our own, improper installation, or to use in violation of instructions furnished by us, nor extend to units which have been repaired or altered outside of our factory, nor to cases where the serial number thereof has been removed, defaced or changed, nor to accessories used therewith not of our own manufacture, nor to electron tubes.

Defective electron tubes should be returned directly to the tube manufacturer for adjustment at the following addresses:

(a) For RCA tubes to: Adjustment Service, RCA at the nearest of the following addresses:

34 Exchange Place Jersey City 2, New Jersey	589 East Illinois Street Chicago 11, Illinois	420 S. San Pedro Street Los Angeles 13, California
--	--	---

(b) For General Electric tubes to:

Adjustment Service  
Owensboro Tube Works  
General Electric Company  
Owensboro, Kentucky

Any part of a unit approved for remedy or exchange hereunder will be remedied or exchanged by the authorized radio dealer or wholesaler without charge to the owner.

This warranty is in lieu of all other warranties expressed or implied and no representative or person is authorized to assume for us any other liability in connection with the sale of our radio products.

### W A R N I N G

The voltages encountered in this piece of equipment are high enough to cause fatal injury! Practice safety rules until they are second nature. Always turn off the high voltage before making any adjustment inside the transmitter. Never depend on a bleeder resistor to discharge filter capacitors. After the power is turned off, short circuit the high voltage circuit. Never operate the transmitter with any other than the recommended fuses in the primary circuit. The fuses will protect your equipment; in case of accidental contact with the high voltage, they may save your life. If children have access to the open transmitter, always disable the primary circuit by removing the fuses, or the high voltage circuits by removing the rectifiers. Always remove the line cord plug from the power source when working inside the transmitter.

275 watts CW and SSB\* ... 200 watts phone...

Bandswitching 160 through 10 meters!

\* with an auxiliary SSB exciter

## Viking "Valiant"

This compact transmitter gives you outstanding flexibility and performance . . . power to punch through terrific QRM! Built-in VFO or crystal controlled, the "Valiant" is completely bandswitching on all amateur bands 160 through 10 meters . . . delivers a full 275 watts input on CW and SSB (with an auxiliary SSB exciter) and 200 watts on AM. VFO is temperature compensated and extremely stable — operates in the 1.75 to 2.0 mc and 7.0 to 7.45 mc ranges.

The "Valiant" is designed with a high efficiency pi-network tank circuit which will match antenna loads from 50 to 600 ohms and tune out large amounts of reactance — final tank coil is silver plated. Other features: complete TVI suppression; timed sequence (grid block) keying; high gain push-to-talk audio system for use with high impedance crystal or dynamic microphones; low level audio clipping; built-in low pass audio filter; self contained power supplies; and single control mode switching.

As an exciter, the "Valiant" will drive any of the popular kilowatt level tubes and will provide a high quality speech driver system for high powered modulators. A nine pin receptacle on the rear of the transmitter brings out TVI filtered control and audio leads for exciter operation. This receptacle permits the "Valiant" to be used as a filament and plate power source, and also as a modulator for auxiliary equipment such as a VHF transmitter.

**FREQUENCY CONTROL** — The "Valiant" may be operated by built-in VFO or crystal control. The VFO is temperature compensated and extremely stable . . . each band has separate bandspread calibration. Dual tank circuit operates on 1.7 to 2.0 and 7.0 to 7.45 mcs with separate compensation for each frequency range. Excellent tuning accuracy and extremely smooth control is possible with the 6 to 1 planetary drive mechanism which controls tuning. Plexiglas dial is edge-lighted, Plexiglas pointer is positioned to insure a minimum of parallax. Each band is divided into precise 10 kc increments for accurate dial readings and interpolation. The broad range of the VFO permits coverage of an entire band and VFO is easy to tune . . . may be zeroed to any receiver.

**TUNING** — The "Valiant's" basic tuning controls are located on the VFO dial escutcheon. QSY within the phone or CW portion of a band is usually possible by merely changing the VFO frequency setting. For larger frequency excursions, simply touch up the grid (buffer) tuning, adjust loading, and dip the final.

**OUTPUT CIRCUIT** — An efficient pi-network tank circuit with a silver plated inductor is used in the final amplifier. Designed to handle 50 to 600 ohm resistive antenna loads, it will also tune out large amounts of reactance. Final amplifier tubes are three 6146's. RF output is available through a standard SO-239 coaxial connector at the rear of the chassis.

**AUDIO SYSTEM** — The "Valiant" has a high gain audio circuit which provides reserve gain for use with high impedance crystal or dynamic microphones and features push-to-talk control. Low level audio clipping prevents overmodulation and increases average modulation level and intelligibility. Built-in low pass audio filter restricts the audio range to 3500 CPS, thus providing maximum communication effectiveness with minimum bandwidth.

**TIMED SEQUENCE KEYING** — This highly flexible keying system applies wave shaping to the keyed amplifier stages for perfect "make" and "break" on your keyed signal. Signal clicks and chirps are eliminated, yet the "break-in" advantages of a keyed VFO are retained. The delay period is adjustable; and the system may be set to operate so fast that a breaking station may be heard between transmitted dots! Electrically operated, timed sequence keying uses no relays and only one dual triode plus a rectifier tube for the grid block bias.

**TVI SUPPRESSION** — Completely TVI suppressed, the "Valiant" cabinet is electrically sealed with flexible monel braid on the inside of the front panel and large cabinet overlap — a cup type shield seals the meter. Power line and relay jack have double "L" type filters — all auxiliary socket, meter, key, and dial lamp leads have "L" filter networks. Interior harness leads and filaments are by-passed. Careful by-passing of the final and special circuit techniques minimize harmonics in the output circuit.

**POWER SUPPLIES** — Self-contained high voltage power supply uses choke input filtering — delivers 620 volts at 500 ma. Self-contained low voltage power supply will deliver 300 volts at 90 ma and 6.3 volts AC at 6 amps. A separate relay jack provides 115 V AC for antenna change-over and control relays, and is energized by the "operate" switch on the front panel or the push-to-talk circuit.

Two VR-105 voltage regulators are used to regulate the final amplifier screen voltage in SSB operation and the modulator screen voltage during AM operation. VFO screen voltage is regulated by an OA2 voltage regulator.

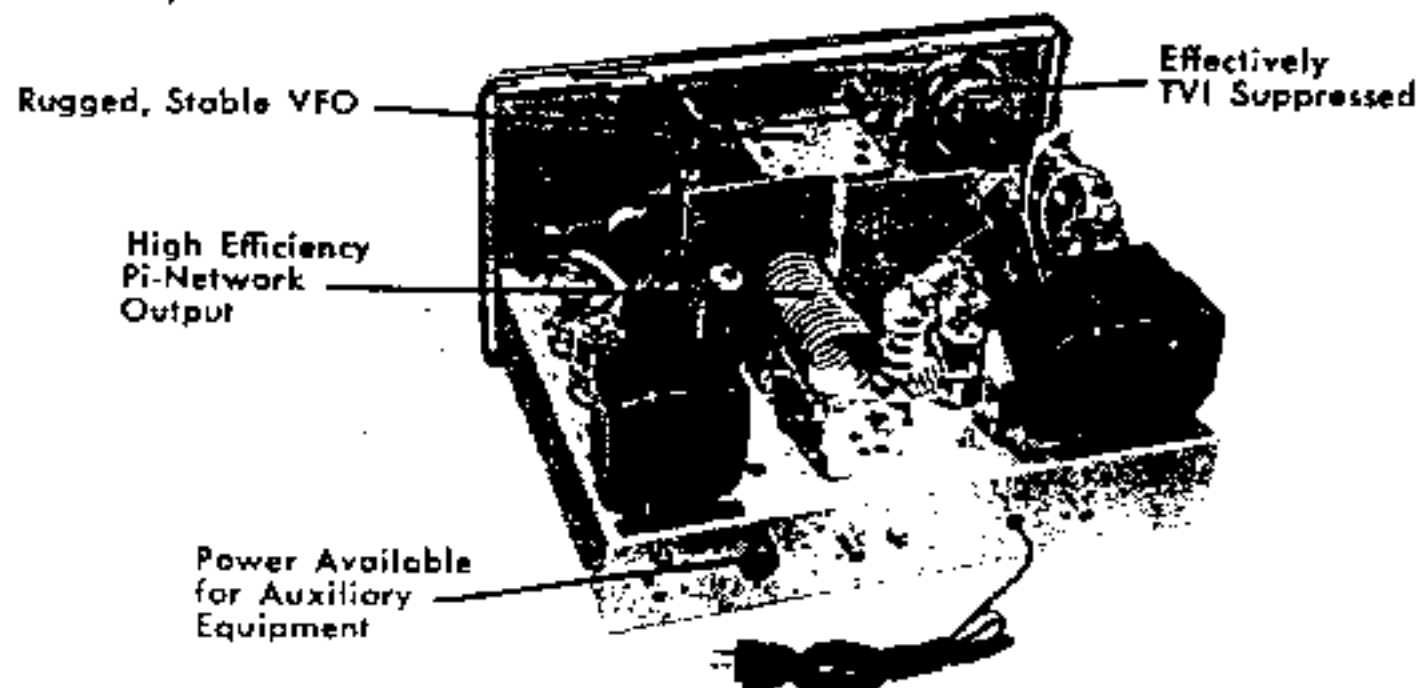

## SPECIFICATIONS

### FREQUENCY RANGE:

160, 80, 40, 20, 15, 11, and 10 meters

### POWER INPUT:

275 Watts Continuous Wave

275 Watts Single Sideband (With auxiliary SSB exciter)

200 Watts Amplitude Modulated Phone

### POWER REQUIREMENTS:

105-120V AC, 50-60 cycles, single phase

### FUSE PROTECTION:

Transmitter fuses are located in the 115 V. power plug. Separate internal fuse furnishes protection for low voltage power transformer and associated components.

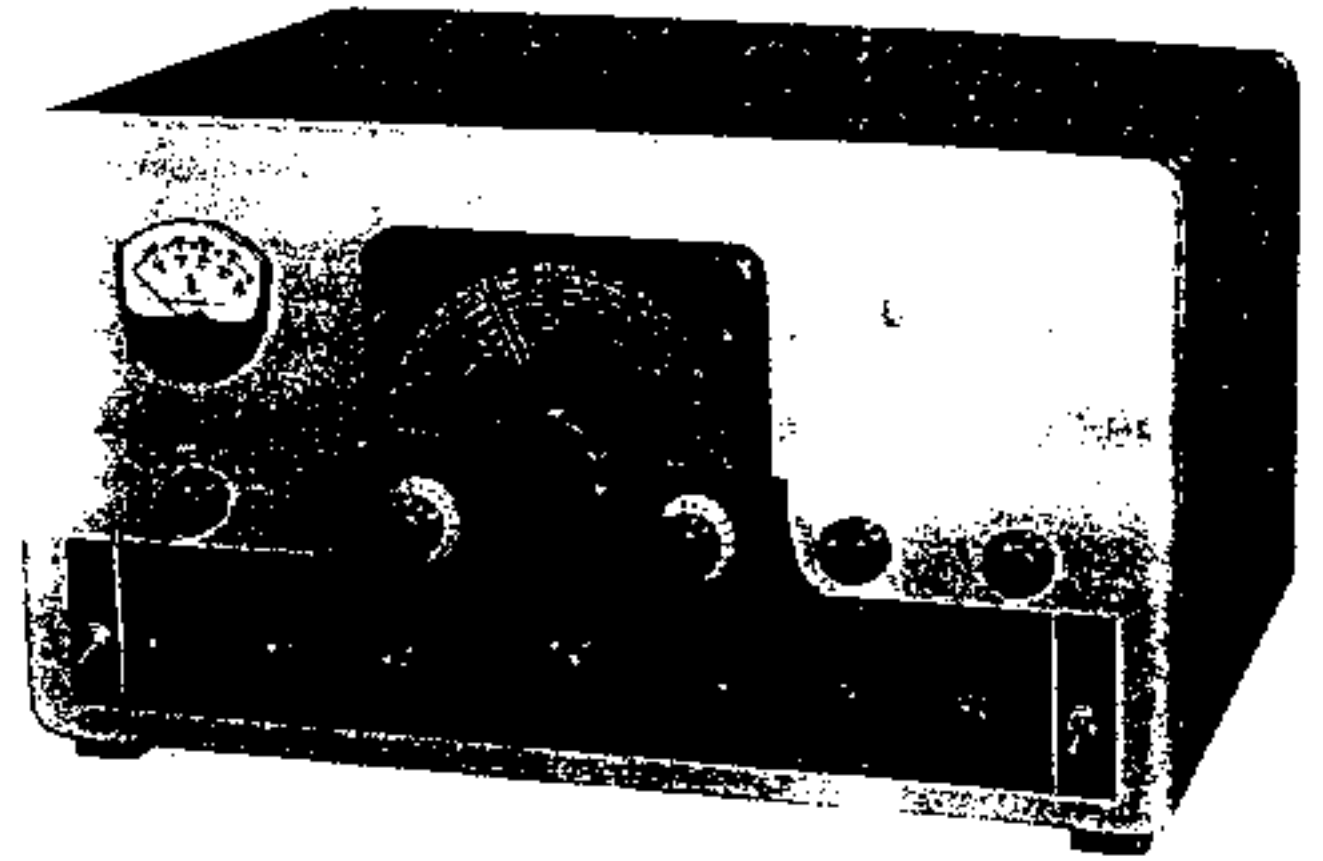

## TUBE LINE-UP

6AU6—Variable Frequency Oscillator  
 0A2—VFO Screen Voltage Regulator  
 6CL6—Crystal Oscillator/VFO Isolator  
 5763—R.F. Driver  
 6146(3)—Parallel Final Amplifier, Bridge Neutralized  
 12AX7—Cascade Speech Amplifier  
 6AL5—Audio Clipper  
 6C4—Audio Amplifier

12AU7—Parallel Audio Driver  
 6146(2)—Push-Pull Class AB2 Modulator  
 12AU7—Time Sequence Keyer  
 6AQ5—Clamper  
 866A(2)—High Voltage Rectifiers  
 5V4G—Low Voltage Rectifier  
 6BY5GA—Bias Rectifier  
 VR-105(2)—Screen Voltage Regulators

The Viking "Valiant" is available completely wired and tested or as an easy to assemble kit. The 18 gauge steel cabinet is finished in attractive maroon and grey, with green nomenclature. Complete kit includes assembly instructions, photographs, diagrams and step-by-step wiring directions. Wiring harness, all necessary hardware furnished—no drilling or metal work necessary. Dimensions: 11 $\frac{1}{2}$ " x 21 $\frac{1}{2}$ " x 17 $\frac{3}{8}$ ". Net Weight: 73 lbs. Shipping Weight: 83 lbs.

Cat. No. 240-104 Viking "Valiant" Kit with tubes, less crystals, key and microphone.

Cat. No. 240-104-2 Viking "Valiant" wired and tested with tubes, less crystals, key and microphone. \$439.50 Amateur Net

# \$349<sup>50</sup>

Amateur Net

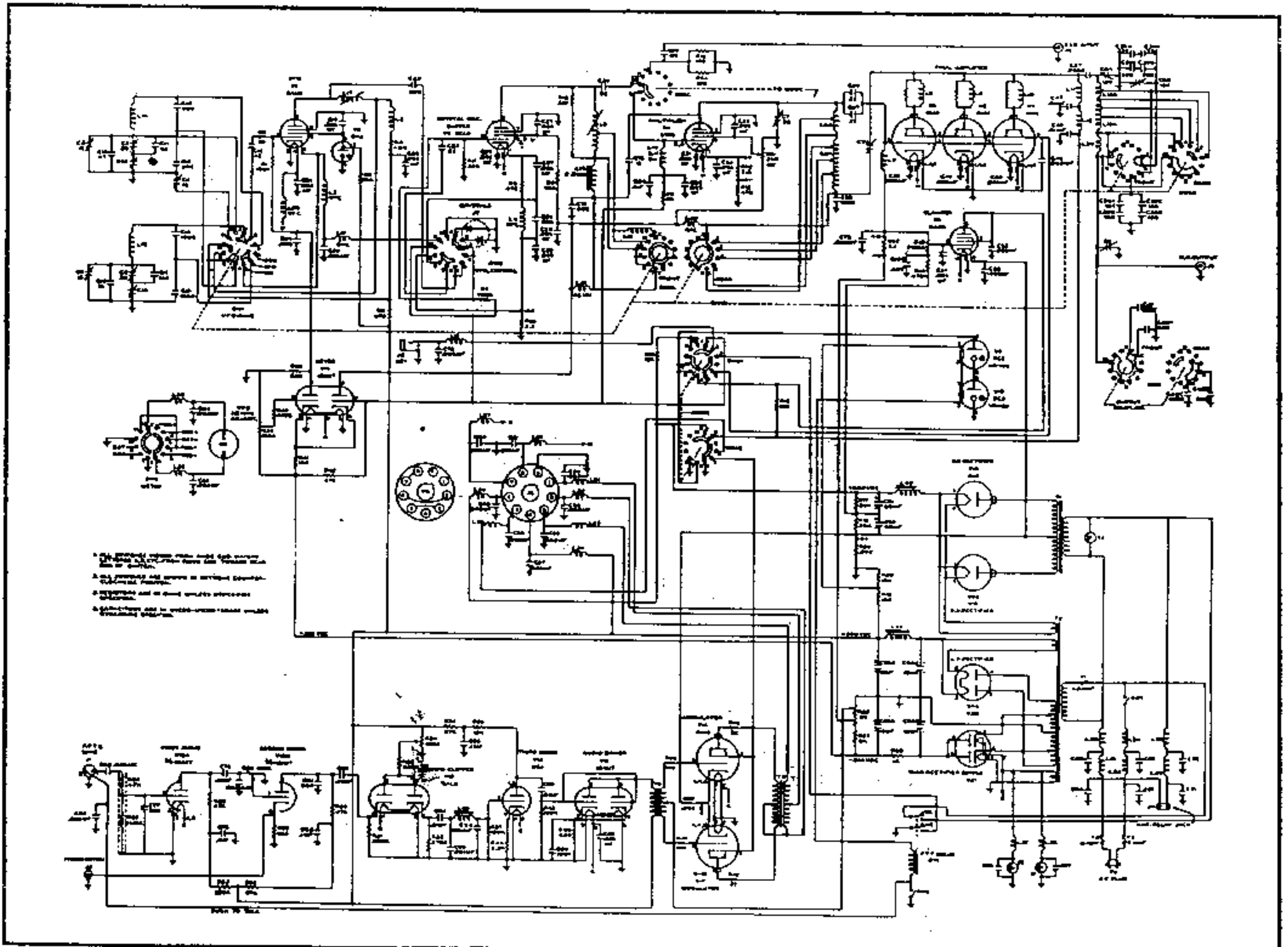

# JOHNSON VIKING VALLIANT TRANSMITTER

Model 240-104-1 (Kit Form)  
240-104-2 (Assembled and Tested)

## OPERATING MANUAL CONTENTS

	<u>Page</u>
A. INTRODUCTION	
1. Function	1
2. Construction	1
3. Auxiliary Equipment	2
4. Power Requirements	2
B. DESCRIPTION	
1. Exciter	2
2. RF Amplifier	3
3. Audio Section	4
4. Power Supplies	5
5. Panel Nomenclature and Control Functions	5
C. INSTALLATION	
1. Unpacking (factory wired transmitter)	6
2. Installation of Knobs	7
3. Bias Adjustment	8
4. Clamper Adjustment	9
5. Operational Checks	9
6. Keyer Adjustment	11
D. OPERATION	
1. Accessory Connections	11
2. VFO Checks	12
3. Tuning Procedure	13
4. Neutralization	15
5. Notes on CW Operation	15
6. Notes on AM Phone Operation	15
7. Clipping Level Adjustment	16
8. Clipping Effects	17
9. Notes on SSB Phone Operation	17
10. SSB Tests	18
E. PI-NETWORK TUNING AND HARMONIC SUPPRESSION	
1. General Information	19
2. Importance of Grounding	20
3. How to Obtain a Good Ground	20
4. Loading Random Antennas	21
5. Loading Precautions	22
6. Coupling to Balanced Loads	23
7. Use of Low Pass Filters	24

## CONTENTS

Page 2

	<u>Page</u>
F. VFO CALIBRATION	
1. Definitions and General Information	24
2. 160, 80 Meter Scale Calibration	25
3. 40, 20, 15, 10 Meter Scale Calibration	26
4. 11 Meter Calibration	26
5. Calibration Against Crystals	26
6. Calibration Against WWV	28
7. Calibration Trouble Shooting	29
G. TROUBLE SHOOTING	29

## TABLES

1. Valiant Voltage Measurements	31
2. Valiant Resistance Measurements	32
3. Transformer and Choke Resistances	33
4. Typical Dial Readings	34
5. Parts List	35

## ILLUSTRATIONS

Following  
Page 40

Figure 1 - Valiant Tube Layout Guide	
2 - Completed Chassis, Top View	
3 - Completed Chassis, Bottom View	
4 - Completed Chassis, Bottom View	
5 - Completed Chassis, Rear View	
6a - VFO Chassis, Top View	
6b - VFO Chassis, Bottom View	
7a - Tube Socket Connections, Bottom View	
7b - Capacitor-Resistor Color Code	
8 - Block Diagram	
9 - Schematic Diagram	
10 - Wiring Harness	
11 - Audio Gain Control Curve	
12a - Push to Talk, Microphone Schematic	
12b - Wiring, Plug P8	
12c - Output Voltages J8 for Auxiliary Apparatus	

## A. INTRODUCTION

### 1. Function

The Viking Valiant is a self contained radio frequency transmitter designed for amateur service. It may be used for CW telegraphy, AM modulated phone or, with a suitable exciter, SSB phone communication.

Approximate final amplifier ratings are:

<u>Mode</u>	<u>Plate Power Input*</u>	<u>RF Output*</u>
CW	275 watts	200 watts
AM	200 watts	150 watts
SSB		150 watts (P.E.P.)

The ranges of operating frequencies are:

1.75 mcs.	to	2.0 mcs.
3.5 mcs.	to	4.0 mcs.
7.0 mcs.	to	7.42 mcs.
14.0 mcs.	to	14.85 mcs.
21.0 mcs.	to	21.6 mcs.
26.9 mcs.	to	27.36 mcs.
28.0 mcs.	to	29.7 mcs.

Maximum output power is essentially constant throughout the operating range.

### 2. Construction

The transmitter is 21 1/8" wide, 17 3/8" deep, 11 5/8" high; weighs 83 pounds net. A perforated cadmium plated steel cabinet and cadmium plated steel panel result in total enclosure with adequate ventilation.

All operating controls are located on the front panel, as well as the meter, frequency determining dial and pilot lamps. Microphone input jack, keying jack, phone patch input, auxiliary power receptacle, SSB input jack, RF output receptacle, relay jack and ground stud are located on the rear of the chassis.

To aid in eliminating spurious radiation which might result in interference to other services such as television broadcasting, the transmitter cabinet serves as an effective shield. Monel metal braid is used to bond the panel and seal all possible openings between the one-piece cabinet and panel. The meter is shielded at the rear and has individual RF filters in meter leads. All external connections such as power cord, microphone input receptacle, relay jack etc. are equipped with individual RF filters to maintain cabinet shielding integrity.

Operating frequency is determined by the bandswitch and high stability, temperature compensated, integral variable frequency oscillator, both controlled from the front panel. The oscillator is calibrated directly in output frequency and the illuminated dial provides calibration points in 10KC increments throughout the frequency range.

Socket J7, located behind a dummy knob cover on the front panel will accommodate two crystals for spot frequency operation.

\*maximum input dependent somewhat on power line voltage  
(P.E.P.) peak envelope power

### A. 3. Auxiliary Equipment

Microphone - - For phone operation a crystal or high impedance dynamic microphone is required. The Valiant is equipped with a low current DC "push-to-talk" relay requiring only a microphone with a "push-to-talk" switch to actuate it.

Key - - Any hand key, "bug" or electronic key available may be used for CW operation. The DC current thru the key is negligible and a keying relay is not required.

SSB Exciter - - For SSB phone operation the transmitter requires approximately 3 watts of single sideband suppressed carrier excitation at the output frequency. This requirement is met by a number of commercially available SSB exciters. The output frequencies available and quality of the SSB signal are dependent upon the design of the accessory exciter.

Antenna Coupler - - Unbalanced resistive antenna loads from 50 to 500 ohms impedance may be matched by the pi-network output tuning system. Antennas are easily designed to fall within this impedance range and an antenna coupler is not then required.

If it is required to work into two wire balanced antenna transmission line systems or to work into highly reactive antenna systems such as may be encountered by using one antenna for a number of different frequency bands, an antenna coupler such as the 250-23 JOHNSON "Matchbox" should be used. Alternative solutions to antenna matching problems may be found in the ARRL Handbook in the chapters "Transmission Lines" and "Antennas".

Low Pass Filter - - While the pi-network output circuit of the Valiant provides good harmonic suppression, there are many locations where harmonic output must be reduced to an absolute minimum to avoid interference with "fringe area" television reception. In this case a low pass filter such as the 250-20 JOHNSON is a highly desirable accessory. Since a low pass filter is a fixed impedance device (52 ohms in the case of the 250-20) antenna impedance matching flexibility must be achieved by using an antenna coupler after the low pass filter.

### 4. Power Requirements

The Valiant is designed to operate from a 117 volt, 50/60 cycle single phase AC line voltage source. Since the variable frequency oscillator and amplifier screen grid voltages are regulated, the equipment is substantially independent of line voltage regulation within the limits 105 to 125 volts. With 117 volts line voltage, power consumption is:

Standby	185 watts
Key down CW (fully loaded)	560 watts
Phone, fully loaded, speech modulation	560 watts (average peaks)

## B. DESCRIPTION

### 1. Exciter

The Valiant exciter section consists of a 6AU6 (V1) variable frequency oscillator, a 6CL6 (V3) crystal oscillator/buffer and a 5763 (V4) frequency multiplier/driver.

1. The primary method used to establish frequency control is the 6AU6 high stability electron coupled oscillator. The oscillator is voltage regulated and temperature compensated. Drift and frequency shift due to temperature rise or line voltage variation are negligible. The construction of these circuits is extremely rigid to minimize the effects of shock or vibration. The 6AU6 oscillator and its associated OA2 (V2) screen voltage regulator are housed in a separate compartment, carefully shielded and isolated from all other radio frequency circuits to avoid frequency modulation of the oscillator output.

The oscillator is equipped with two separate tank circuits, one covering the range 1.75-2.0 mcs. for output on the bands 1.75-2.0 mcs. and 3.5 - 4.0 mcs. The other tank circuit covers basically the range 7.0 - 7.42 mcs. for all other output frequencies except the 11 meter band. Here the oscillator tunes the range 6.725 mcs. to 6.84 mcs. for output in the range 26.9 - 27.36 mcs. Oscillator tank circuits are selected by SW1 actuated from the shaft of the bandswitch SW3 by the drive arm D1 and the cam D2. Oscillator frequency is determined by the capacitor C1A, B driven by the main dial and planetary drive assembly D3.

Using VFO frequency control, the 6CL6 crystal oscillator/buffer serves as a broad banded amplifier/frequency multiplier and serves to further isolate the VFO from succeeding RF stages. The plate circuit is switched by SW3A, the deck of the bandswitch nearest the front of the transmitter.

With switch SW2 in the "C1" or "C2" position the VFO is disabled by removing L19 from ground thus opening the cathode circuit of V1. At the same time, one of the crystals is connected by SW2 between the grid of V3 and ground. V3 then becomes a "hot cathode" crystal oscillator. In the "C1" position of SW2 a crystal connected between pins 3 and 5 of J7 is operative. In the "C2" position the crystal connected between pins 1 and 7 is in use.

With SW2 in the "VFO" position, the cathode of V1 is grounded thru L19, the plate of V1 is connected to the grid of V3 thru the coupling capacitor C22 and the crystals are removed from the circuit.

These same conditions exist when SW2 is switched to the "zero" position plus the fact that SW2 grounds pin 7 of the 12AU7 keyer (V11) thus keying the whole exciter chain.

The 5763 buffer/multiplier (V4) employs a tuned high Q plate circuit operating on the same frequency as the final amplifier on all bands. The plate circuit is switched by SW3A, is tuned from the front panel by C74, the dial being marked "EXCITER". This stage is protected against excitation failure by the cathode resistor R12. The buffer switch and coils are shielded to guard against interaction with other circuits. R13, operated from the front panel and marked "DRIVE" controls the screen voltage of the 5763 thus controlling the excitation to the final amplifier.

## 2. RF Amplifier

This stage employs three 6146 tubes (V5, V6 and V7) connected in parallel. Layout and design is such as to provide high efficiency together with stability and freedom from spurious output. The high Q pi-network output circuit has good efficiency throughout the operating range and provides excellent harmonic suppression when operated into non reactive loads of 50 to 500 ohms impedance. The range of antenna impedance which may be matched at frequencies above 7 mcs. extends, roughly, from 25 to 2,000 ohms. The output capacity switching assembly (C41, C42 and SW6) is arranged to avoid inductive loops coupling back to the preceding stages.

B. 2. The inductance in the plate circuit of the amplifier is switched to change bands by means of the rear deck of SW3B. The amplifier is tuned to resonance by means of C8 operated from the front panel by the dial marked "FINAL". The knob of SW6, the coarse coupling switch, is marked "AUX COUPLING"; the dial operating C9, the output coupling capacitor is marked "COUPLING FINE".

The 6AQ5 clamper (V8) is an integral part of the final amplifier circuit in that it protects the amplifier under conditions of no excitation. With the "MODE SWITCH", SW4, in either the CW or AM phone position, removal of excitation to the final amplifier, either by reason of keying or detuning of the exciter would cause the plate dissipation to rise prohibitively. Removal of excitation to the final amplifier eliminates the self bias generated at the grids of the 6L46s causing the potential at the control grid of the 6AQ5 clamper to shift in a positive direction causing the clamper to draw current. Current flowing in the clamper plate circuit increases the drop thru the resistor R16 thus limiting the potential at the screen grids of the 6L46s and the plate dissipation. With normal excitation to the amplifier the voltage at the grid of the clamper exceeds cutoff, the clamper then having no effect on the circuit.

To operate the Valiant on SSB requires an SSB exciter capable of delivering 3 to 4 watts peak envelope power output at the desired operating frequency. Both the 5763 multiplier and the 6L46 final amplifier tubes are used as linear amplifiers in this mode of operation.

### 3. Audio Section

The speech system consists of a 12AX7 (V12) cascade connected dual triode speech amplifier, 6AL5 (V13) diode audio clipper, 6C4 (V14) third audio amplifier, 12AU7 (V15) audio driver and push-pull 6L46 (V16, V17) modulators.

Two audio inputs are provided: J1 on the rear of the chassis is the microphone input. Terminal 1 connects the audio output of either a crystal or high impedance dynamic microphone to the grid of the first audio stage. Terminal 2 and ground of J1 connect in parallel with SW8 and if a push-to-talk microphone is used, the switch in the microphone actuates the push-to-talk relay, RY1. The phone jack, J3, also on the rear of the chassis, serves as a phone patch input. It connects between cathode and ground of the second audio stage (V12B) and is in parallel with the cathode resistor, R29. This lead should be blocked by a 0.1 mfd capacitor to prevent shorting of the cathode resistor by the phone patch circuit if such a capacitor is not part of the phone patch unit.

The audio clipper (V13) will provide up to 20DB of speech clipping, markedly improving the effectiveness of the transmitter signal. The audio filter following consisting of C94, C95 and L45, may be considered as a part of the clipper since it is used to correct the audio wave form after clipping. The filter also serves to limit the frequency response to the range 250 to 3000 cycles. Modulation level and degree of clipping are controlled by R34, the clipping level control on the front panel marked "CLIPPING", and by R28, the audio gain control mounted on the front panel and marked "AUDIO".

### 4. Power Supplies

Three supplies are used to power the Valiant. The low voltage supply rated at a nominal 300 volts serves the exciter and speech system exclusive of the modulator. The power transformer is T2 and the rectifier a 5V4G (V20). A separate winding of T2 connected to the cathodes of the 6BY5GA rectifier (V21) serves to supply rectified bias of -265 volts to the transmitter.

B. 4. The high voltage supply of 660 volts consists of the power transformer T1 and the 866A rectifiers (V18, V19). It serves to power the modulators and the final amplifier.

The low voltage supply and bias supply as well as all filaments are energized by switch SW7 located on the left side of the front panel and marked "FIL". The high voltage supply is energized by the relay RY1 actuated by either SW8 or by a microphone switch connected between pin 2 and ground of J1.

All supplies are protected by the 8 ampere 3AG power line fuses F2 and F3 located in the AC plug P9. A third fuse F1, 1.5 amperes 3AG is located inside the chassis on the rear edge. This fuse serves to protect the circuits associated with T2. These circuits are independent of amplifier loading and a failure of F1 is indicative of trouble which requires opening of the transmitter to service.

Two separate voltage regulation circuits are incorporated in the Valiant. One circuit, an OA2 (V2) regulates the screen voltage of the VFO (V1) for maximum frequency stability. The second regulator circuit using two OC3/VR-105 tubes (V9, V10) holds the screen voltage of the final amplifier to close limits when operating the amplifier as a SSB linear amplifier. When the Valiant is operated in the AM mode, the pair of VR-105s regulates the screen voltage of the 6146 modulators (V16, V17).

The receptacle J8 has been provided to permit the use of the Valiant power supplies and modulator for other equipments such as a VHF transmitter. Removal of the shorting plug P8 from J8 disables the entire RF section by removing the filament voltage. J8 then has available at its terminals the output of the modulator, approximately 100 watts of audio, 6.3 volts AC at 9 amperes, 660 volts DC at 350 ma., 300 volts DC at 75 ma. The 660 volts DC may be taken out of the transmitter either modulated or as DC thus eliminating the necessity for external modulator wiring. Any associated equipment, used with the Valiant powering it, is controlled by the Valiant control system. If push-to-talk operation is to be used and a keying circuit is required then the output from J4 will operate a 110 volt AC relay to perform any required function.

Normal use for J4 is to supply 110 volts AC keyed by the relay RY1 to operate an antenna change over relay.

#### 5. Panel Nomenclature and Control Functions

FIL - - Switch SW7, in the up or "on" position applies power to transformer T2 applying filament voltage to all tubes, plate and screen voltage to all stages except final amplifier and modulator. Applies fixed bias voltage to exciter stages, final amplifier, modulator and driver.

PTT-MAN - - Switch SW8, in the up or "Man" position applies power to T1 putting plate and screen grid voltage on final amplifier and modulator. SW8 does not function unless SW7 is "on". The up position is for manual control and the down position (PTT) is for push-to-talk relay control by means of the microphone push-to-talk switch.

METER - - Switch SW5, connects meter M1 to measure various transmitter currents:

B. 5.	<u>SW5 Position</u>	<u>Current</u>	<u>Stage</u>	<u>Scale</u>	<u>Tubes</u>
	OFF	- - -	- - -	- - -	- - -
	OSC	Cathode	Osc/Buffer	0 - 50	V3
	BUFF	Cathode	Multiplier	0 - 50	V4
	GRID	Grid	Final Amp.	0 - 25	V5, 6, 7
	PLATE	Cathode	Final Amp.	0 - 500	V5, 6, 7
	MOD	Cathode	Modulator	0 - 250	V16, 17

EXCITER - - C7<sup>4</sup>, tunes the plate circuit of the multiplier, V<sup>4</sup>.

VFO - - C1<sup>A</sup>, B determines VFO frequency within the frequency band.

FINAL - - C8<sup>A</sup>, B tank tuning capacitor for final amplifier.

DRIVE - - R5<sup>1</sup>, controls screen voltage applied to V<sup>4</sup> thereby controlling excitation to final amplifier grids.

CLIPPING - - R3<sup>4</sup>, audio clipping level control

OSCILLATOR - - Switch SW<sup>2</sup>, selects either of two crystals or VFO frequency control. In the "zero" position, SW<sup>2</sup> keys the exciter chain.

MODE - - Switch SW<sup>4</sup>, on the "CW" position grounds the screen grids of the modulators and short circuits the secondary of the modulation transformer. In the "AM" position applies regulated voltage to modulator screen grids, opens up the modulator transformer secondary short circuit. In the "SSB" position applies regulated screen voltage to the final amplifier, removes excitation from V<sup>3</sup> to multiplier V<sup>4</sup> and disables modulator.

CRYSTALS - - Dummy knob conceals socket J<sup>7</sup> accommodating two FT243 type crystal holders. Crystal C<sup>1</sup> plugs into socket terminals 3 and 5, crystal C<sup>2</sup> into socket terminals 7 and 1.

BAND - - Switches SW<sup>1</sup> and SW<sup>3</sup>, selects VFO tank circuit and determines tuning range of succeeding exciter stages and final amplifier.

AUX COUPLING - - Switch SW<sup>6</sup> adjusts the output coupling capacity of the final amplifier pi-network by selecting fixed mica capacitors.

COUPLING FINE - - C<sup>9</sup>, variable air dielectric capacitor, a component of the pi-network output circuit. This capacitor together with fixed mica capacitors provides a continuously variable output loading capacitor.

AUDIO - - R<sup>28</sup>, 1 meg potentiometer adjusts audio input to the second audio stage, determines modulator output level.

## C. INSTALLATION

### 1. Unpacking (factory wired transmitter)

After removing the transmitter from its shipping container, inspect it thoroughly for any possible damage from shipping. Claims against the carrier delivering the equipment must be made with the carrier's agent at the point of delivery. DO NOT SHIP DAMAGED EQUIPMENT BACK TO THE MANUFACTURER UNTIL AUTHORIZED TO DO SO BY THE MANUFACTURER. NOTIFY THE SERVICE DIVISION THAT A CLAIM IS BEING MADE AGAINST THE CARRIER.

- C. 1. In order to attach the knobs, install tubes and remove packing material it will be necessary to remove the transmitter from the cabinet as follows:
- a. Loosen and remove the four tie bolts which are located at the top, left and right ends of the rear of the cabinet.
  - b. Loosen and remove the screws around the periphery of the cutout located on the rear of the cabinet.
  - c. Slide the chassis out of the cabinet carefully, training the line cord thru the large opening.

Remove the packages containing the knobs and the three plugs, P8, a nine pin plug with cover, P3, a phono plug, P4, antenna relay plug.

Remove the packing from around the final amplifier coil and any additional packing inside the cabinet and on the chassis.

Remove the supports provided underneath the chassis on the transformer mounting screws.

Install any tubes which are separately wrapped. Refer to Figure 1 for locations and Figure 9, the schematic diagram for the tube type numbers corresponding to the "V" numbers appearing on Figure 1. V1 and V2 will already be installed in the VFO compartment.

Check to see that all plate cap connectors are in place.

Replace transmitter in cabinet after performing all tests and operation is normal.

## 2. Installation of Knobs

Install knobs as follows (set screws for all knobs are shipped separately and are installed at time of mounting).

Install the large 2 3/8" knob, using one 10-32 set screw, on the 1/4" shaft extending from the VFO planetary drive, being careful not to permit the knob to rub the VFO dial escutcheon. Tighten the set screw.

Directly below the VFO dial knob, install the 1 5/8" knob on the "BAND" switch shaft extension using two 8-32 set screws. Set the switch to the maximum counter-clockwise position and set the knob marker to coincide with the 160 meter mark. Tighten the set screws.

Install one of the 0-100 dials on the shaft marked "EXCITER". Adjust the dial to "0" with capacitor C7 fully meshed. Tighten the 8-32 set screw.

Install the remaining 0-100 dial on the shaft marked "FINAL". Adjust the dial to "0" with the ganged capacitor C8A, B fully meshed. Tighten the 8-32 set screw.

Install the balance of the knobs using 8-32 set screws as follows:

C. 2. <u>Panel Nomenclature</u>	<u>Shaft Position</u>	<u>Knob Marker Position</u>
METER	counterclockwise	"Off"
OSCILLATOR	counterclockwise	"Cl"
MODE	counterclockwise	"CW"
AUX COUPLING	counterclockwise	"0"
FINE COUPLING	C9 meshed	"0"
AUDIO	counterclockwise	"0"
DRIVE	counterclockwise	"0"
CLIPPING	counterclockwise	"0"

Check the function of each knob to see that the indexing agrees with the marking on the panel (i.e. BAND switch on 160 meters with the switch at the counterclockwise position and 11 meters when fully clockwise).

### 3. Bias Adjustment

NOTE: The operation of this equipment involves the use of high voltages dangerous to human life. Use extreme care and caution.

Turn the clamper potentiometer R13 (located to the right of V8) to its full clockwise position.

Check to see that both of the 8 ampere fuses are installed in the line cord plug.

Check to see that P8 is installed in J8 on the rear of the chassis.

With SW7 (marked FIL) and SW8 (marked MAN-PTT) both off (down) insert plug into 117 volt line.

Bias voltages for the modulator and final amplifier are established by means of the adjustable taps on R22, the 5,000 ohm 25 watt resistor located underneath the chassis directly below socket XV21. These adjustments have already been made on factory wired transmitters.

Rough adjustment for kits should be made as follows. Set one tap 1/2" from the terminal which is connected to R23 (9K ohms 10 watts). Set the other tap 1" from the same terminal.

For finish adjustment set transmitter controls:

<u>Control</u>	<u>Position</u>
MODE	CW
DRIVE	0
SW8	Off
SW7	On
AUDIO	0

Final amplifier grid voltage should be 70 volts negative with respect to ground. Turn SW7 off for each adjustment. Set the tap nearest to the terminal connected to R23 for -70 volts amplifier grid voltage (measure at either end of L7 and ground).

- C. 3. To adjust the remaining tap of R22 (nearest the ground end) set controls:  
(Make adjustments with SW7 and SW8 off).

<u>Control</u>	<u>Position</u>
MODE	AM
DRIVE	08
METER	Mod
SW7	On
SW8	On
AUDIO	0

Voltage read at modulator grids should be -55 volts. Do not permit modulator current to run over 80 ma. for any length of time while making adjustments.

These adjustments should result in operating conditions of 60 ma. static modulator current on AM phone, 70 ma. static amplifier plate current on SSB operation.

#### 4. Clamper Adjustment

The clamper is used to reduce screen voltage automatically under conditions of no excitation to the final amplifier. It is adjusted by means of R13, a potentiometer with slotted shaft located near the rear of the chassis next to the clamper tube V8 (6AQ5). This adjustment need be made only once, should be re-checked when changing V8, the 6AQ5 clamper or the 6146 tubes in the final amplifier.

Set up transmitter controls as follows:

<u>Control</u>	<u>Position</u>
METER	Plate
OSCILLATOR	C1 (no crystals in crystal socket)
MODE	CW
SW7	On
SW8	Off
AUDIO	0

R13 was previously turned to the full clockwise stop. Throw SW8 to "MAN" position (on). Using an insulated screwdriver turn R13 slowly counterclockwise until plate current just begins to rise. Set R13 for 10 ma. static plate current. Turn SW8 to PTT position (off). BE CAREFUL, DO NOT GET ACROSS THE HIGH VOLTAGE!

#### 5. Operational Checks

a. Position the controls as follows:

<u>Control</u>	<u>Position</u>
VFO	3.5 mcs.
METER	Osc.
MODE	CW
OSCILLATOR	VFO
BAND	80
AUX COUPLING	0
DRIVE	0
AUDIO	0

C. 5. a. Settings of other controls is not important at this time.

Turn SW7 to "on" position and allow transmitter to warm up for a few minutes.

"Osc" current should read approximately 24 ma. (multiply bottom meter scale reading by two).

"Buff" current should read approximately 6 ma. (twice reading of bottom scale). Turn DRIVE control to 3 and note that "buffer" current will rise to about 22 ma.

Turn METER switch to "grid", tune EXCITER dial for maximum current with DRIVE at position 3.

Adjust DRIVE control for 3 ma. grid current (bottom meter scale).

Turn METER switch to "plate", turn SW8 to "Man" position and tune FINAL dial for minimum current. Plate current should read approximately 80 ma. on the upper meter scale. Turn SW8 off, (PTT position).

b. Turn controls as follows:

<u>Control</u>	<u>Position</u>
VFO	7.33 mcs.
OSC	VFO
MODE	CW
BAND	40
AUX COUPLING	0
DRIVE	5
AUDIO	0

Tune EXCITER dial for maximum grid current.

Adjust L17 (screwdriver adjustment under chassis beneath the VFO for maximum "grid" current. (This adjustment will remain unchanged).

Adjust DRIVE control for 4 ma. grid current.

Turn SW8 to "man" position (on), tune FINAL dial for minimum current, approximately 90 ma. on the top scale. Turn SW8 off (PTT position).

c. Turn controls as follows:

<u>Control</u>	<u>Position</u>
VFO	28.6 mcs.
OSC	VFO
MODE	CW
BAND	10
AUX COUPLING	0
DRIVE	5
AUDIO	0

Tune EXCITER dial for maximum grid current. If necessary to obtain a reading, advance DRIVE control beyond 5.

- C. 5. c. Adjust L5, the screwdriver adjustment to the left of the VFO (beside the shaft of C7), for maximum grid current. (This adjustment will remain unchanged).
- d. Set VFO at 27.125 mc. BAND on 11. Adjust L16 by squeezing or spreading turns, for maximum grid current. NOTE: If 12 ma. or more grid current is obtained with DRIVE at position 10, L16 need not be adjusted.

## 6. Keyer Adjustment

The keyer control R39 is a potentiometer with slotted shaft located to the left of and slightly to the rear of V3 (6CL6). Plug a key into J2. Set transmitter controls:

<u>Control</u>	<u>Position</u>
OSCILLATOR	VFO
SW7	On
MODE	CW
DRIVE	0
AUDIO	0
SW8	Off

Set bandswitch and VFO to any convenient receiving frequency. Close key and tune the receiver to the VFO frequency. If more signal is required, turn the DRIVE control to 2 and tune EXCITER dial for maximum received signal. Open the key. Rotate R39 to the full clockwise position. This will key the VFO. Now turn R39 slowly counterclockwise until the VFO drops out of oscillation. Do not leave the keyer adjustment at exactly the point where the VFO drops out of self sustained oscillation. Turn R39 counterclockwise slightly beyond this point otherwise VFO instability can result.

## D 1. Accessory Connections

The possible connections to auxiliary equipment provided in the Valiant are listed below. The ones actually used depend upon the modes of operation and optional equipment utilized.

<u>Accessory</u>	<u>Connector</u>	<u>Cable</u>	<u>Connections</u>
Microphone	P1 (80-MC2M Amphenol)	2 conductor shielded (furnished with microphone)	To P1 connect; audio lead from microphone to pin 1, switch lead from microphone to pin 2, shield braid to shell. Insert P1 into J1
Key	P2 (75 Mallory or equal)	2 conductor unshielded	To P2; connect one lead to each terminal. Insert P2 into J2
Antenna	P6 (83-1SP Amphenol)	Optional	If coaxial cable is used to connect antenna; center cond. to center pin of P6, shield braid to shell. If single lead is used connect to center pin of P6. Insert P6 into J6

D. 1.	<u>Accessory</u>	<u>Connector</u>	<u>Cable</u>	<u>Connections</u>
	Antenna Relay	P4*	2 conductor unshielded	Connect one lead to each terminal of P4. Insert into J4. Note that this circuit delivers 115V AC keyed by relay RY1.
	Phone Patch	P3*	single conductor shielded	Connect center conductor to center pin of P3, shield to shell. Insert in J3.
	SSB Input	P5 (83-1SP Amphenol)	RG59/U	Center conductor to center pin of P5, shield to shell. Insert in J5.
	Accessory Power	P8*	user's option	P8 is normally wired to complete heater and modulator output circuits when the transmitter is operated. Insert into J8. Refer to special instructions for using accessories such as the Viking 6N2.

\* Furnished with the Valiant

## 2. VFO Checks

Wired transmitters leave the factory with VFOs calibrated and there is little danger of calibration changing. However, many times the operator will depend inadvertently on oscillator calibration to insure operating within band limits and for this reason VFO calibration should be checked at band edges.

One method of checking VFO calibration is to use a communications receiver as a detector. The frequency standard such as an LM type frequency meter, 100kc crystal calibrator or other standard should be fed into the receiver at a level which will not block the receiver yet produce a strong enough beat with the BFO to be easily detected.

The transmitter can be set up as follows:

SW7	On
OSCILLATOR	VFO position
MODE	CW "
DRIVE	0 "

It is not necessary to tune any of the stages other than the VFO. Run a lead from the center contact of J6 letting it lie near the receiver antenna terminals. Adjust the lead position so as to provide a signal of approximately the same level as the calibrator.

With the Valiant bandswitch in the 160 meter position beat the VFO with the calibrator at the calibration check points nearest 1.75 mcs. first, then nearest 2.0 mcs. These checks may be made at 3.5 mcs. and 4.0 mcs. if desired. The receiver BFO should be turned off, the beat between calibrator and VFO providing the audible check. The transmitter bandswitch may be in either the 160 or 80 meter position.

- D. 2. Next turn transmitter bandswitch to the 40 meter position. Compare VFO frequency with the calibrator as follows:

<u>VFO Actual Oscillating Freq.</u>	<u>VFO Dial Reading</u>	<u>Frequencies Thus Checked</u>
7.0 mcs.	7.0 mcs.	7.0 mcs. 14.0 mcs. 21.0 mcs. 28.0 mcs.
7.15 mcs.	21.450 mcs.	21.450 mcs.
7.175 mcs.	14.350 mcs.	14.350 mcs.
7.425 mcs.	29.7 mcs.	29.7 mcs.

If it will simplify checking frequency, the receiver and calibrator may be operated on the frequencies indicated by the VFO dial. Checks will then be made against oscillator harmonics.

If a 100 kc. standard is the frequency comparison device there is no way to check such frequencies as 14.35 mcs. or 21.45 mcs. directly using audible beats. It becomes necessary then to check against the 100 kc. standard harmonics (multiples of 100 kc.).

To check 14.35 mcs., set the VFO to the 40 meter position, the VFO dial to 14.3 mcs. and the receiver to 14.3 mcs. The second harmonic of the VFO will then beat against the 143rd harmonic of the 100 kc. standard. Next tune the receiver and the VFO dial to 14.4 mcs., beating the VFO second harmonic against the 144th harmonic of the crystal calibrator. If calibration is accurate at 14.3 mcs. and at 14.4 mcs. then it can be assumed that the VFO calibration at 14.35 mcs. is quite accurate. The same technique can be used to check 21.45 mcs.

Turn bandswitch to 11 meter position and perform the following checks:

<u>VFO Actual Oscillating Freq.</u>	<u>VFO Dial Reading</u>	<u>Frequencies Thus Checked</u>
6.74 mcs.	26.960 mcs.	26.960 mcs.
6.8075 mcs.	27.230 mcs.	27.230 mcs.

If these checks disclose discrepancies in VFO calibration and if the calibrator used is known to be .005% accurate or better, then the VFO should be recalibrated per the instructions appearing later in this manual.

### 3. Tuning Procedure

**NOTICE!** The regulations of the Federal Communications Commission require a suitable license for operation of this equipment. Refer to publications of the Federal Communications Commission or the American Radio Relay League for the latest rules governing station and operator licensing.

Be sure to return the enclosed warranty registration card. This will register your transmitter at the factory. If it becomes necessary to write to the factory regarding your transmitter, refer to it by serial number.

3. The tuning procedure for the Viking Valiant is identical on all bands of operation, 160 thru 10 meters. Therefore, the discussion of tuning on one band will apply to all bands. Only the dial and switch settings will change when going from one band to another. A 100 watt or larger light bulb should be used for a dummy load. Connect the dummy load between the center conductor and shell of J6. Connect a ground lead to the stud adjacent to J6.

Set the Valiant control knobs:

<u>Panel Nomenclature</u>	<u>Position</u>
FIL (SW7)	Down (off)
METER	Off
MODE	CW
BAND	40
VFO	7.05 mcs.
AUX COUPLING	0
COUPLING FINE	0
DRIVE	0
AUDIO	0
CLIPPING	10
MAN-PTT (SW8)	Down (off)

Insert the AC plug into 117 V AC 60 CPS receptacle. Turn FIL switch (SW7) "on". Permit transmitter to warm up two minutes or more.

Turn METER switch to "osc", note that the oscillator is drawing current. Turn METER switch to "buffer".

Turn OSCILLATOR switch to "zero" thus keying the transmitter. Note that the buffer now draws a slight amount of current.

Turn DRIVE control to 3.

Turn METER switch to "grid", tune EXCITER dial for maximum grid current. Adjust grid current to 8 ma. by turning DRIVE control.

Turn METER switch to "plate".

Immediately after throwing SW8 to "man" position (on) tune final dial for minimum current (resonance).

Load amplifier by advancing AUX COUPLING switch a step at a time in a clockwise direction, retuning FINAL dial for resonance after each switch change.

As the amplifier approaches normal loading, 450 ma. for CW operation 330 ma. for AM phone operation, complete loading of the amplifier by means of the COUPLING FINE control. Advance the COUPLING FINE control in a clockwise direction in small increments retuning to resonance each time with the FINAL dial.

Readjust DRIVE control for 8 ma. grid current.

Return OSCILLATOR switch to VFO position opening the key.

NOTE: Improper neutralization is very likely to become evident when loading the amplifier and adjusting grid current. Bringing the grid current up to the normal 8 ma. will cause the amplifier plate current to rise beyond the normal value. Reducing the amplifier loading will then cause the grid current to fall off. The net result of

- D. 3. improper neutralization is to make it almost impossible to load the amplifier to the proper 330 ma. or 450 ma. while maintaining recommended 8 am. grid current. Refer to neutralization covered in section D.5.

#### 4. Neutralization

The power amplifier of the Valiant is neutralized by the double spaced variable capacitor C74 mounted in the corner of the shield SH1.

CAUTION! THE NEUTRALIZING CAPACITOR HAS FULL PLATE VOLTAGE APPLIED TO IT. ADJUSTMENT SHOULD BE MADE WITH AN INSULATED SCREWDRIVER.

Tune up the transmitter at any convenient frequency on the 20 meter band and load the amplifier to about 250 ma. with the dummy load. Note the exact reading of the FINAL dial where resonance (minimum plate current) occurs.

Turn meter switch to the grid position. Detune the final dial slightly in the direction which causes grid current to increase. (Don't move FINAL dial far nor leave the amplifier out of resonance very long because plate current increases rapidly and plate dissipation becomes prohibitive.)

If an increase in grid current occurs with a decrease in FINAL dial reading, the neutralizing capacity is too great.

If an increase in grid current occurs with an increase in FINAL dial reading, the neutralizing capacity is too small.

Adjust C74 in the direction indicated, retune amplifier to resonance. While observing grid current, detune FINAL dial again in the direction causing grid current to rise. Repeat this step as necessary.

The amplifier is neutralized when detuning the FINAL causes little or no change in grid current or when detuning the FINAL dial in either direction causes grid current to fall off. Neutralization occurs with C74 at about 1/4 of maximum capacity.

#### 5. Notes on CW Operation

The final amplifier should be loaded up to 450 ma. current indicated on the "plate" position of the METER switch. Grid current should be 8 ma. indicated on the "grid" position of the meter switch. Bear in mind that in the special condition where SW8 is in the PTT or off position but the exciter is keyed or the OSCILLATOR switch is in the "zero" position, grid current can rise several milliamperes over the value established when the amplifier is "on" and loaded.

An antenna changeover relay may be operated by the 115V AC power furnished by J4 when SW8 is in the "man" or "on" position. This mode precludes the use of full break-in operation.

To operate full break-in requires either the use of a separate receiving antenna or a TR box. Under these conditions SW8 is left "on" while operating.

To "zero beat" another station, turn SW8 off then turn the OSCILLATOR switch to the "zero" position. With SW8 on, the "zero" OSCILLATOR position keys the entire RF section of the transmitter.

#### 6. Notes on AM Phone Operation

Nominal input to the final amplifier is 330 ma. on phone. With speech modulation and peak modulator current running approximately 165 ma., 100% modulation is achieved. The "no signal" static modulator current runs between 60 and 80 ma. (modulator current is read on the middle 250 ma. meter scale).

- D. 6. The amount of grid current applied to the final amplifier will affect the grid voltage of both the final amplifier and modulator. Therefore, the tap on R22 nearest ground, should be set for 60 to 80 ma. static modulator current with 8 ma. drive to the final grids. The transmitter should then always be operated with 8 ma. grid current on AM phone.

#### Typical Values - AM Phone Operation

$I_k$ - amplifier	330 ma.	$I_k$ modulator (static)	60 - 80 ma.
$E_g$ - amplifier	-82 volts	$E_g$ modulator	-55 volts
$I_g$ - amplifier	8 ma.		

The operator has two choices in controlling the transmitter carrier. The carrier can be switched manually using SW8 (MAN-PTT switch) or with a microphone switch to provide push-to-talk operation. The switch leads are connected between terminal 2 and the shell of P1. P1 plugs into J1 on the rear of the chassis. Either type of operation will actuate a 115V AC antenna relay connected to J4.

#### 7. Clipping Level Adjustment

The desired amount of speech clipping can best be established by means of a cathode ray oscilloscope, however an alternate method also follows. The oscilloscope should be set up to check for 100% modulation. (Information on hook-up and scope patterns may be obtained from the ARRL Handbook.) Set the AUDIO gain control R28 at "0", the CLIPPING control R34 in the full clockwise position. Put the transmitter in operation normally loaded for phone operation. While talking in the normal tone of voice used for communication, with the microphone in its regular position, advance the AUDIO control until 100% modulation is achieved on modulation peaks. While continuing to talk into the microphone, turn the CLIPPING control counterclockwise until it is observed that modulation peaks are being slightly clipped. This serves to establish the threshold of clipping at 100% modulation.

The alternate method of adjusting clipping requires that the operator be able to talk into the microphone at a fairly constant amplitude and that he keep the same distance from the microphone.

Turn the CLIPPING control to the full clockwise position. Load the final amplifier to 330 ma. current with 8 ma. drive. While talking into the microphone at as constant level as can be maintained, turn the AUDIO control clockwise until the meter reads peaks of 175 to 200 ma. in the MOD position. Next turn the CLIPPING control to the full counterclockwise position. Talk into the microphone at the same level as before turning the clipping control slowly clockwise until modulator current once again reaches 175 to 200 ma. peaks. LEAVE THE CLIPPING CONTROL IN THIS POSITION. The clipping control setting will be approximately at 2 to 3.

Now refer to the curve "audio gain control position", Figure 11. Find the point on the curve corresponding to the present setting of the AUDIO control. Refer to the left side of the chart and determine the "relative gain DB" at this point on the curve. If 10db of clipping is desired, add 10 to the relative gain figure just obtained. Project this new figure over to intersect the curve and read the AUDIO gain position indicated. Turn the AUDIO control to this new position. This setting will give 10db of clipping.

As an example, let us suppose that the setting of the AUDIO which provides 100% modulation is 5. This point is 78db on the relative gain scale. Ten db added to this is 88db which corresponds to a new AUDIO gain setting of between 6 and 7 for 10 db of clipping.

D. 7. It may be noticed that the oscilloscope will indicate some overmodulation under these conditions. This results from phase shift as clipped wave forms pass thru the filter and modulation transformer. In well designed transmitters, this slight effect will not be detrimental. If desired, this effect can be eliminated by adjusting the CLIPPING control. Turn the CLIPPING control in a counterclockwise direction slightly and check modulation. Repeat as necessary until overmodulation is eliminated.

#### 8. Clipping Effects

Clipping is useful in overcoming interference but the recognizability of the operator's voice decreases as more clipping is used. Generally 10 to 12 db of clipping is the maximum desirable. The background noise present limits the amount of clipping which can be effectively used. A condition of high background noise together with excessive clipping will result in nearly 100% modulation of the carrier by the noise thus obscuring the operator's voice and reducing intelligibility.

The following tabulation of the effects of speech clipping should aid in selecting the clipping level to be used.

- 6 db peak clipping - - clipping is barely detectable
- 12 db peak clipping - - not at all objectionable, on the contrary, speech sounds as though the speaker is enunciating with special care
- 15 db peak clipping - - begins to interfere somewhat with the recognizability of the speaker.
- 18 db peak clipping - - speech sounds somewhat sharp and rasping but less unnatural than speech over a throat microphone.
- 24 db peak clipping - - speech quite intelligible but sounds unnatural and grating.

#### 9 Notes on SSB Phone Operation

When the MODE switch SW<sup>4</sup> of the Valiant is turned to the SSB position, regulated screen voltage is applied to the final amplifier and a 50 ohm loading resistor is connected between grid and ground of V<sup>4</sup>, the 5763 multiplier stage. The fixed grid bias to the final amplifier is unchanged, however, the new mode of operation will eliminate grid current and thereby remove the bias ordinarily generated across R<sup>22</sup>.

While the 50 ohm resistor (R<sup>10</sup>, R<sup>54</sup> in parallel) from grid to ground will load the exciter considerably it may be necessary to further dissipate exciter output. Operating the SSB exciter near or at full output will insure maximum attenuation of noise, hum and the suppressed sideband.

In SSB operation it is important that the final amplifier be loaded properly. When the loading is too light the amplifier is driven into saturation prematurely and the output is considerably reduced. If the coupling is too tight saturation is no problem but the output will be below that of proper coupling. To establish correct loading the transmitter may be tuned up at the anticipated operating frequency with SW<sup>4</sup> in the CW position. The final amplifier should be loaded up to 450 ma. "plate" current to the final amplifier using the regular CW tuning routine and with normal grid current. Both EXCITER and FINAL TUNING WILL BE LEFT UNCHANGED FROM THIS POINT ON. Turn SW<sup>8</sup> off, throw MODE switch to the SSB position.

- D. 9. Throw SW8 back on, adjust the DRIVE control so that with the meter in the "buffer" position, static current of the 5763 is 20 ma. Apply SSB excitation (at the same frequency as tuned in the CW mode) to J5 of the Valiant. With voice modulation, increase the SSB exciter audio gain until the meter, in the "grid" position, barely flicks upward on voice peaks. (Peaks as high as 1/2 ma. would be indicative of serious overdrive.) Turn the meter switch to the "plate" position. Depending upon the operator's voice and the waveform of the audio from the SSB exciter, modulation peaks should read between 180 and 240 ma. The true value of these peaks appreciably exceeds 250 ma. but due to meter inertia and the short duration of peaks, the meter reading is considerably less.

If more convenient, the transmitter may be tuned using the carrier output of the SSB exciter driving the Valiant multiplier and final amplifier. There is then no possibility of forgetting to tune these stages to the correct frequency. The mode switch should be in the SSB position, SW8 off. Using the carrier control of the exciter and the DRIVE control of the Valiant set grid current near the normal 8 ma. level turn SW8 on, load the final amplifier to 450 ma. Turn the DRIVE control counterclockwise to the stop. Switch the exciter to the SSB mode, turn the drive control clockwise until the "buffer" current is 20 ma. Turn up exciter audio gain while talking into the microphone until the meter in the "grid" position barely flicks upward.

#### 10. SSB Tests

SSB performance may be tested using only a cathode ray oscilloscope having an adjustable horizontal sweep and an audio signal generator. The audio signal generator may be a simple oscillator operating at a fixed frequency between 250 and 1000 cycles.

If a SSB transmitter is modulated with a 1,000 cycle tone, the output would appear as a continuous wave signal 1000 cycles removed from the original carrier frequency. If the transmitter system for suppressing the carrier is then deliberately upset, an AM sideband will appear at the same frequency but out of phase with the SSB sideband. By adjusting the degree of imbalance in the sideband suppression system and the amount of audio applied thru the exciter audio input jack, an oscilloscope wave form can be produced which appears as a series of positive and negative halves of sine waves, the bottoms of the waves coinciding on a common base line. This scope pattern with rounded tops and bottoms and with intersections forming an "X" are indicative of linear output of the system. The quality of the test pattern obtained from the Valiant departs slightly from the ideal but indicates a degree of linearity far better than required for amateur communication service.

Adjust the final amplifier loading in accordance with the preceding instructions. With the SSB exciter feeding the transmitter in the SSB mode of operation, inject carrier and at the same time introduce the audio signal to the exciter audio input.

Feed a sample of the amplifier output directly to the vertical plates of a cathode ray oscilloscope. Set the internal horizontal sweep to approximately four times the audio modulation frequency. Adjust the amplitude of the RF sample so it fits conveniently in the scope face. Vary the exciter audio control and carrier injection so that the test pattern described is produced. If the halves of sine waves do not meet in the center of the scope, too little audio is being applied. If the tops and bottoms of the wave forms are cut off, too much carrier is being injected. Increase carrier injection and audio to the point where the wave forms are beginning to be slightly distorted by flattening on tops and bottoms. "Plate" current at this point of saturation should be about 300 ma. under conditions of proper loading.

D. 10. Leave the test set-up as is. Substitute the microphone for the audio oscillator previously used. Readjust the exciter to eliminate the carrier component of its output. Speak into the microphone in a normal manner and adjust the audio control while watching the scope. It will be easy to note the point where peaks start to be clipped. THIS IS THE LIMIT OF AUDIO INPUT. Note the plate current peak reading where clipping just begins with this particular transmitter and do not exceed this current. The indicated peak current will vary depending upon the operator's voice. Peaks of 210 to 240 ma. may be considered typical.

Typical Values - SSB Phone Operation

Amplifier cathode current (resting)	70 ma.
Amplifier grid voltage	-72 volts
Amplifier cathode current (voice peaks)	210-240 ma. (meter reading)
Amplifier cathode current (saturated condition with tone modulation)	Approximately 300 ma.
Amplifier grid current	barely perceptible

E. PI-NETWORK TUNING AND HARMONIC SUPPRESSION

1. General Information

The pi-tuning/coupling network in the Viking Valiant is designed to load the final amplifier into antenna resistances of nominally 50 to 500 ohms throughout the frequency range of the transmitter. In addition, it is capable of "tuning out" series antenna reactances up to several hundred ohms to complete a good match to most unbalanced antenna systems. The range of antenna impedances which may be matched by the pi-network at frequencies higher than 7.0 mcs. extends from roughly 25 to 2000 ohms.

When the transmitter is well grounded and properly tuned, the higher harmonic suppression is excellent, generally much better than with other conventional methods of antenna coupling. This should be of interest to amateurs afflicted with TVI or other high frequency interference problems.

The circuit below is the equivalent of the output circuit of the Valiant.

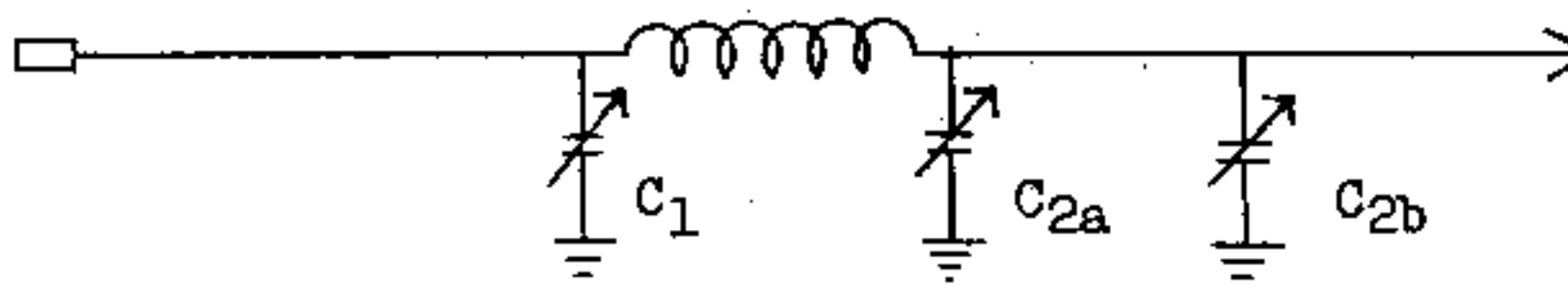

- C<sub>1</sub> - FINAL dial
- C<sub>2a</sub> - AUX COUPLING knob
- C<sub>2b</sub> - COUPLING FINE knob

The tuning technique consists of resonating the circuit initially with C<sub>1</sub>. Both C<sub>2a</sub> and C<sub>2b</sub> are at their counterclockwise (maximum capacity) positions. The amplifier is coupled to the load by successively reducing the capacity of C<sub>2a</sub> and/or C<sub>2b</sub> in small increments and tuning out reactance after each capacity change by tuning C<sub>1</sub> to resonance (minimum current). As the antenna takes power, the minimum amplifier current is established at progressively higher levels until the amplifier is loaded to full rated power input.

## E. 2. Importance of Grounding

To obtain proper tuning, coupling and harmonic suppression with any unbalanced transmitter antenna coupling system, the part of the circuit designed to operate at RF ground potential must be at RF ground potential. A "room full of RF" is evidence that a high RF potential exists on some object in or near the room. In many cases the source of RF appears to be the transmitter chassis and power cord. This condition is very undesirable for several reasons. The power cord is very closely coupled to the chassis by the electrostatic shields of power transformers. Three objectionable factors affecting transmitter performance when poor grounds are involved are:

- a. The impedance that the output terminal of the transmitter looks into includes not only the true antenna to ground impedance presented by the feed line but also the equivalent series transmitter chassis to ground impedance. This additional impedance can, in some cases, raise the apparent antenna impedance to such a high value that it cannot be loaded by the pi-network.
- b. Part of the transmitter power is lost in the ground system due to radiation of the ground lead, power cord or cabinet. This power is quickly dissipated in surrounding objects and contributes nothing to effective radiated power.
- c. Practical design considerations make it necessary to bypass possible sources of stray high frequency currents to the transmitter chassis. When a high impedance exists between transmitter chassis and ground these stray currents can radiate to a certain extent.

## 3. How to Obtain a Good Ground

What may appear to be a good ground at one frequency may prove to be a poor ground at another. A single ground lead may have "standing waves" on it due to its length. While it may seem difficult to obtain a good ground over a wide range of frequencies, it can be done and will be well worth the trouble when increased radiation efficiency, ease of antenna loading and reduced TVI and BCI result. There is also reduced danger of damaging microphones, receivers and other associated equipment with excessive RF fields.

Avoid using the power line, power line conduit or gas lines for RF grounding. Some suggestions which may help to obtain a good ground are:

- a. Water pipes or metal building structural members are usually good sources of earth grounds.
- b. Use heavy conductors (#14 or larger) between the connection at the ground point and the transmitter. Copper ribbon is excellent for this purpose.
- c. The use of several ground leads, each of a different length and selected at random may be helpful in keeping the grounding impedance low at the transmitter, even though the transmitter is some distance from a true earth ground. The possibility of obtaining an effective ground at any frequency throughout the transmitter's range is quite good. If at any one frequency, one of the ground leads presents a low impedance at the chassis, the chassis is effectively grounded. By changing the length of one of the ground leads experimentally, a good ground can often be obtained at a frequency which has been troublesome. In bringing several leads to the transmitter, small closed loops near the transmitter or antenna feed line should be avoided. Induction fields will tend to raise the impedance of the ground leads.

- E. 3. d. In cases where it is impossible to obtain a good earth ground, connecting the transmitter chassis to some system of conductors having a very low effective impedance to ground compared to the antenna impedance may be helpful. Usually this artificial "ground" takes the form of a system of radial wires spread horizontally on the floor, a gridwork of wires, or a large metal sheet on the floor below the transmitter. To be most effective, the minimum area covered by the metal conductors should be roughly equivalent to a square, the length of one side of which approaches a quarter wavelength at the lowest operating frequency. This system of grounding should be experimented with before committing the location to any permanent installation.
- e. A simple counterpoise made up of a single wire attached to the chassis may be helpful. On 10 meters, a length of 6 to 8 feet may be attached and the open end cut off 4 inches at a time until the chassis becomes "cold". The open end of the wire may be allowed to drop along the floor although its open end will be somewhat "hot" with RF.
- f. A rough check on the effectiveness of the transmitter ground may be made by touching the chassis while watching the PA plate current and grid current with the transmitter operating into an antenna. A change in current upon touching the chassis is indicative of an ineffective ground. In cases where the transmitter is feeding a low impedance antenna, test by touching the cabinet with a neon lamp. The presence of 50 to 60 volts will ignite the neon lamp.

#### 4. Loading Random Antennas

With the transmitter chassis well grounded, correctly designed antenna systems having relatively "flat" unbalanced feeder systems can easily be loaded by following the instructions previously given. This assumes that the antenna terminal impedances fall within the range of the pi-network. If the feedline is over a quarter wavelength long, feeding a balanced system (one transmission line lead to the center terminal of J6, the other side to transmitter ground stud) may prove surprisingly successful provided the transmitter cabinet is held at ground potential. Some standing waves will result but may not prove excessive. The Johnson Matchbox, a universal all band, bandswitched antenna coupler will permit loading of the Viking Pacemaker to any practical antenna system. In addition, it provides for the use of the Johnson 250-20 Low Pass Filter for increased harmonic suppression.

Antennas having random lengths, random feed points and various types of feed lines will exhibit widely different resistance and reactance characteristics. It is well to remember that the feedline is a very important part of the system. A common example of the random antenna is a horizontal wire fed by a single wire feed line. The feed line in this case actually becomes part of the radiating system. An antenna of this type can, in most instances, be fed by the pi-network directly but there are critical dimensions where the antenna series reactance (inductive or capacitive) becomes too high and the antenna resistance can become either too high or too low to be matched by the pi-network.

Antennas with high terminal resistance or reactance can be recognized while loading the output stage of the Viking Valiant. The final amplifier is loaded by reducing the total of the output coupling capacity by adjusting either or both the AUX COUPLING and FINE COUPLING controls. As the output coupling capacity is reduced in small steps, retuning the amplifier to resonance each time, the minimum plate current is increased. Normally this process is continued until full loading of

- E. 4. the amplifier is achieved. If, however, a point is reached where decreasing the output coupling capacity does not result in a marked increase in PA plate current and the PA is not fully loaded, the antenna can be assumed to have a high resistance or reactance at this frequency.

Antennas with low terminal impedance (resistance and reactance both low) can be recognized by a noticeable lack of coupling capacitor effect in the range of settings normally used at the operating frequency. It may prove impossible to decouple the amplifier sufficiently for normal loading.

Several methods may be used in an effort to bring the antenna system into the tuning range of the pi-network:

- a. Change the length of the feeder line between the antenna and transmitter experimentally  $1/8$  to  $1/4$  wavelength.
- b. Change the point of connection of the feedline to the antenna  $1/8$  to  $1/4$  wavelength.
- c. Change the antenna length  $1/8$  to  $1/4$  wavelength. Antennas shorter than  $1/8$  wavelength (antenna and feeder) may be difficult to load. They present a high capacitive reactance to the transmitter output terminals. Effective antenna lengths in the vicinity of  $1/2$  wavelength will have little reactance but very high resistance making them difficult to load.
- d. "Load" the antenna feeder by placing an inductor or capacitor in series to cancel out the reactance of the antenna feeder. This may require considerable cut and try and will affect only the reactive component of the antenna impedance. It does prove useful in some cases.
- e. L type matching networks of inductance and capacitance may be used to aid impedance matching. Much discussion of this more elaborate method of bringing the antenna impedance within the range of the pi-network could be included, however, the few cases where it is necessary do not justify inclusion herein. Textbook and handbook discussions will be helpful if work along this line is pursued. There is danger of resonating the coupling capacitor of the pi-network when using an external coil. This should be watched as excessive voltage built up across the coupling capacitors can cause damage. Improper coupling or loading will take place under these conditions.

## 5. Loading Precautions

When loading high impedance antennas there is a temptation to "squeeze" the last watt into the antenna by opening the coupling capacitors as much as possible. Harmonic suppression is dependent, to a great extent, on the amount of coupling capacity remaining in the circuit. It is wise to use as much coupling capacity as is practical at all times. The proper amount of coupling when antenna impedance is high, can be conveniently determined by holding a neon lamp against the antenna feeder. The coupling capacitor can then be opened until little increase in glow is noticed when the coupling capacitor and tuning controls are adjusted for maximum output. A decrease in coupling capacitance beyond this point may cause a higher plate current reading due to reduced plate circuit efficiency. Higher harmonic output will also result as the coupling capacity is reduced beyond the point where output has levelled off. The random antenna system may present a more favorable impedance to harmonic output than the output on the fundamental frequency; hence it is well to use as much coupling capacity as is practical.

- E. 5. It is well to remember that the amount of coupling capacitance needed is dependent on operating frequency. For example, 2,000 micro microfarads at 3.5 mcs. corresponds to 160 micro microfarads at 28.0 mcs. These are the values necessary to couple resistive loads of approximately 50 ohms, at the frequencies stated.

If the power line voltage is low or the high voltage rectifiers have low emission, the loaded plate current may not reach the normal value. This condition should not be confused with the inability of the pi-network to load an antenna system.

## 6. Coupling to Balanced Loads

Balanced antennas such as center fed "Zepps", beams and folded dipoles normally use a two wire transmission line and should have equal voltages, 180 degrees out of phase. Applied to each feedline terminal. Since the output of the Viking Valiant is single ended, unbalanced, a coupler is required for balanced antenna systems. The JOHNSON Matchbox, a universal, all band, bandswitched antenna coupler will permit loading of the Valiant to any practical antenna system. In addition, it provides for the use of the JOHNSON 250-20 Low Pass Filter for increased harmonic suppression. A simple coupler for this purpose is shown below. The tank circuit is resonant at the operating frequency and can be excited by a coaxial line and coupling link. Line impedance is not critical although 52 ohm line will be most desirable if a JOHNSON Low Pass Filter is used.

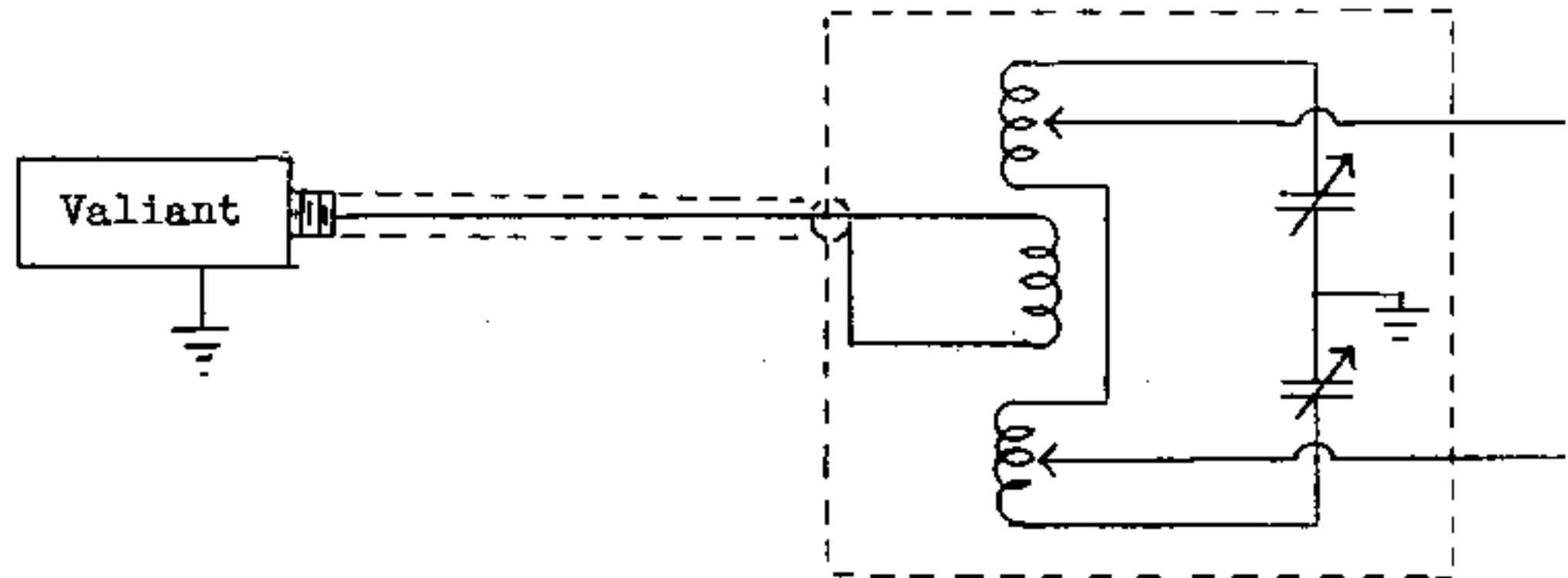

Feedpoint impedance of the coupler is adjusted by means of the inductor taps. Tap adjustment is unnecessary with the JOHNSON Matchbox. Final amplifier loading is adjusted with the transmitter output coupling controls.

Tuning of the coupler can be made quite broad by making the L/C ratio as high as possible (low Q) while still permitting the desired loading. Inductive reactance of the coupling link may make it impossible to reduce the SWR of the coaxial line to below 1 1/2 to 1. If so, the link circuit may be made series resonant by adding capacitor  $C_1$  as shown below:

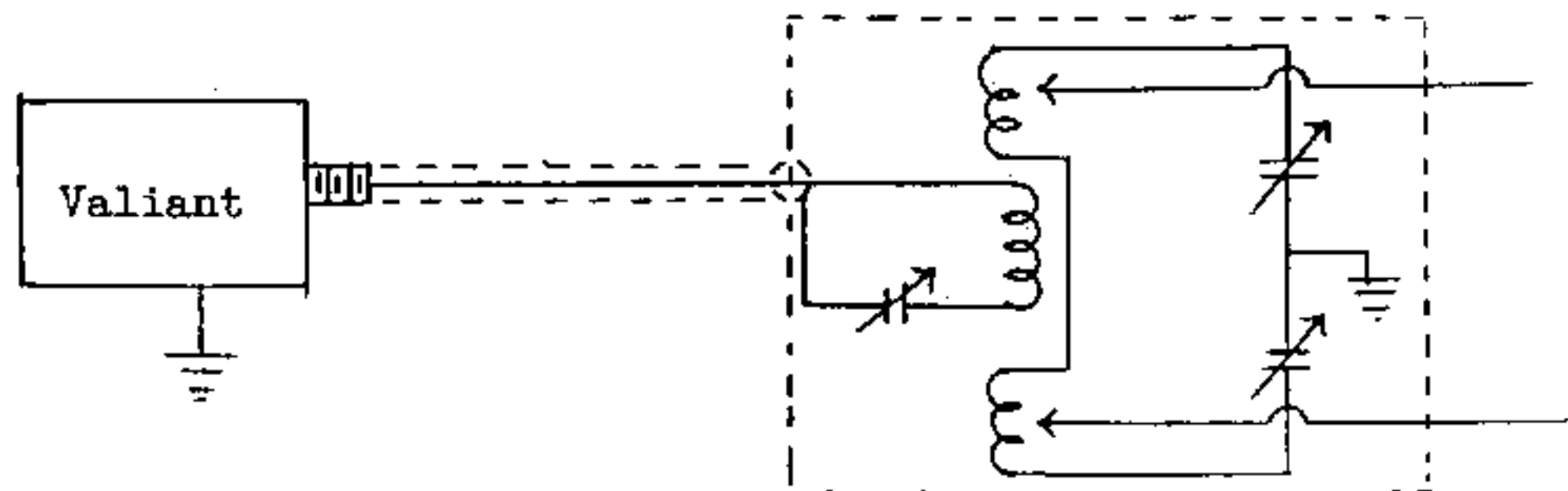

This problem is non-existent with the Matchbox.

## E. 7. Use of Low Pass Filters

Depending upon how it is tuned, 2nd harmonic attenuation of the Viking Valiant amplifier can be as high as 30 db. Since this will permit operation in many locations without television interference, the JOHNSON 250-20 Low Pass Filter is not an integral component of the Valiant, but is available as an optional accessory. This filter will provide an additional 75 db or more harmonic attenuation with insertion loss less than .25 db. Characteristic impedance is 52 ohms, power rating 1 KW. The low pass filter may be inserted in the coaxial line between the transmitter and the antenna coupler. Coaxial connectors are used at the transmitter and at both ends of the low pass filter to preserve the shielding provided by the coaxial line. It is preferable that the standing wave ration on the coaxial line between the Valiant and the coupler be maintained at 2 to 1 or less, therefore, the impedance of the line should be the same as the characteristic impedance of the filter. (The JOHNSON 250-20 Low Pass Filter and JOHNSON Matchbox are both 52 ohms impedance.) The section of coaxial line between the transmitter and the low pass filter should be as short as possible and electrical quarter waves should be avoided. An RF bridge such as the JOHNSON 250-25, for measuring SWR will prove invaluable for both initial set-up and for operational checks.

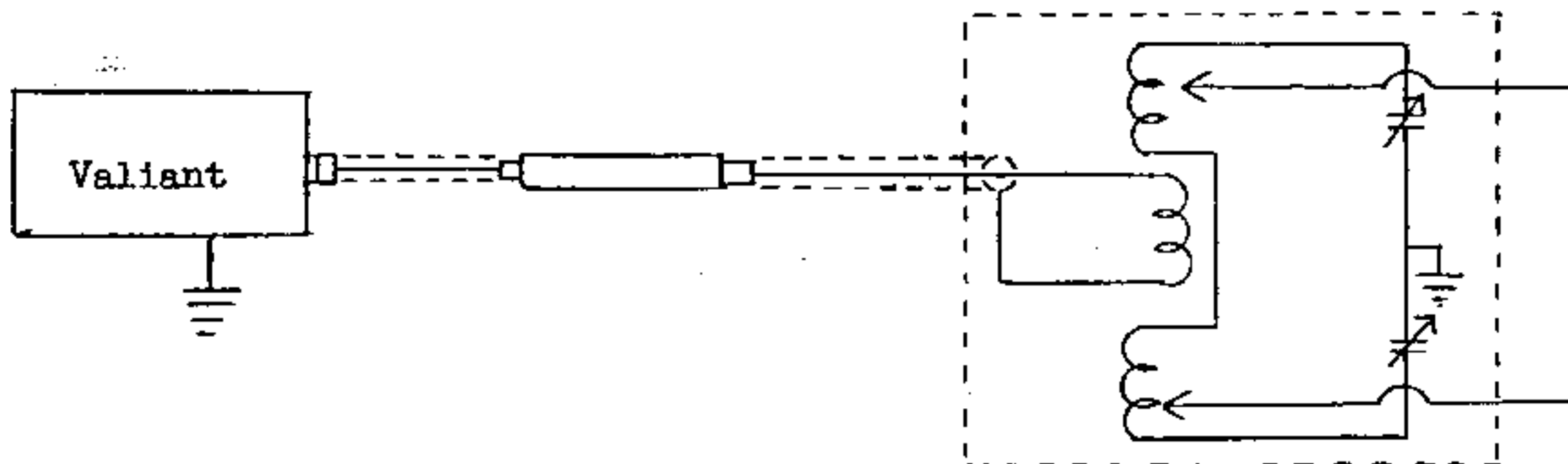

An end fed half-wave antenna may present loading problems, both from the standpoint that its impedance is higher than can be matched by the pi-network amplifier of the Valiant, or that the low output coupling capacitance used reduces inherent harmonic attenuation below tolerable values. Therefore, the use of a half wave antenna may create TVI problems while other antennas prove perfectly satisfactory. In these cases it is recommended that the JOHNSON Matchbox be used.

## F. VFO CALIBRATION

### 1. Definitions and General Information

The following instructions are for calibrating the Viking Valiant VFO using a signal generator for the frequency standard and a receiver capable of tuning the calibration frequencies.

The accuracy of the Valiant VFO calibration will be no better than that of the signal generator used to calibrate it. To fully utilize the stability and calibration capabilities of the VFO, the frequency standard used to calibrate it should have an accuracy of .005% or better. Most crystal standards or crystal calibrated variable frequency standards are satisfactory for normal calibration purposes. A moderate signal output is required, capable of being easily detected with the receiver to be used for zero beat indication.

The frequencies F1a, F2a, F3a and F4a used in the text following are indicated output frequencies of the calibrating standard. The abbreviations F1, F2, F3 and F4 are VFO dial settings corresponding to frequencies F1a, F2a, F3a and F4a respectively. (F1a, F2a, F3a and F4a may be either fundamental frequencies or any harmonic it is desired to use.)

- F. 1. F1a Any given frequency (preferably a frequency corresponding to a low frequency VFO dial calibration mark) between 1.75 and 1.78 mcs. or any of the first eight harmonics of 1.75 to 1.78 mcs. in the range of the receiver. 1.76, 3.52, 5.28, 7.04, and 8.80 mcs. are good calibrating frequencies.
- F2a Any given frequency (preferably a frequency corresponding to a low frequency VFO dial calibration mark) between 1.96 and 2.00 mcs. or any of the first eight harmonics of 1.96 to 2.00 mcs. in the range of the receiver. 1.97, 3.94, 5.91, 7.88, and 9.85 mcs. are good calibrating frequencies.
- F3a Any given frequency (preferably a frequency corresponding to a high frequency VFO dial calibration mark) between 7.00 and 7.07 mcs. or any of the first four harmonics of 7.00 to 7.07 mcs. in the range of the receiver. 7.03, 14.06, 21.09 and 28.12 are good calibrating frequencies.
- F4a Any given frequency (preferably a frequency corresponding to a high frequency VFO dial calibration mark) between 7.35 and 7.425 mcs. or the first four harmonics of 7.35 to 7.425 mcs. 7.40, 14.800, 22.2 and 29.6 mcs. are good calibrating frequencies.

Warm up the signal generator for at least half an hour or as long as suggested by the signal generator instructions before using it for VFO calibration.

Set up a receiver capable of detecting each of the frequencies selected. Attach antenna leads to the receiver input and the signal generator output. (Three or four foot lengths will probably be ample.) Bring the leads closer together until signal generator output can be picked up by the receiver. Separate and shorten the leads as found necessary to keep the receiver from blocking due to excessive signal input. Allow the receiver to warm up for about 1/2 hour to stabilize the local oscillator and log dial settings for frequencies F1a, F2a, F3a and F4a. The beat frequency oscillator in the receiver may be used to log and compare the signal generator and VFO frequencies but it is desirable to obtain the final zero beat indications between VFO and signal generator signals without the beat frequency oscillator. Avoid setting the receiver on or logging image frequencies.

Warm up the Viking Valiant in the "Zero" position of the OSCILLATOR switch with SW8 off for 1/2 hour. Turn the bandswitch to the 160 or 80 position. Turn the VFO dial pointer to the frequency F1, between 1.75 and 1.78 mcs. chosen for the low 160 meter calibrating point and find it or its harmonic (near F1a) on the receiver. Repeat the same procedure at the high 160 meter calibrating point and the 40 meter high and low points after moving the bandswitch to the 40 meter position.

## 2. 160, 80 Meter Scale Calibration

Set the Valiant bandswitch on the 160 or 80 meter position and the dial at F2, the dial reading corresponding to the frequency between 1.96 and 2.00 mcs. chosen for the high 160 meter calibrating point. Set the signal generator to F2a and tune in the signal on the receiver. Adjust the "160 hi" trimmer on top of the VFO (Figure 1) until the VFO zero beats with the signal generator.

Turn the signal generator to F1a, tune the receiver to the same frequency, turn the VFO to F1 and adjust the "160 lo" padder atop the VFO until the VFO zero beats with the signal generator.

F. 2. Repeat the "160 hi" and "160 lo" adjustments, zero beating the signal generator and VFO as accurately as possible. Since the adjustments affect each other several repeats of the adjustments may be necessary before attaining the most accurate setting possible.

### 3. 40, 20, 15, 10 Meter Scale Calibration

Set the Valiant bandswitch on the 40 or 20 meter position and the dial pointer at  $F_4$  on the high frequency dial scale, the frequency between 7.35 and 7.425 mcs. chosen for the high 40 meter calibration. Set the signal generator and the receiver at  $F_{4a}$ . Adjust the "40 hi" trimmer at the top of the VFO until the VFO zero beats with the signal generator.

Turn the VFO to  $F_3$ , the setting corresponding with the frequency between 7.00 and 7.07 mcs. chosen for the low 40 meter calibration, the receiver to  $F_{3a}$ , the signal generator to  $F_{3a}$  and adjust the "40 lo" padder until the VFO zero beats with the signal generator.

Repeat the "40 hi" and "40 lo" adjustments, zero beating the signal generator and VFO as accurately as possible.

### 4. 11 Meter Calibration

The 11 meter band VFO output is near 6.75 mcs. A given frequency,  $F_{5a}$ , in the range 6.7 to 6.85 mcs. or any of the first four harmonics of the 6.7 to 6.85 mcs. range may be used to calibrate the 11 meter range. Turn the Valiant bandswitch to the 11 meter band, set the VFO dial to the position  $F_5$  corresponding to the frequency  $F_{5a}$  or its harmonic which falls in the 11 meter band. Set the receiver to the 11 meter range or a subharmonic and detect the standard signal frequency. Adjust the "11 meter" trimmer until the VFO zero beats with the standard frequency.

Recheck the 40 or 20 meter calibration after the 11 meter adjustment. There is little likelihood that further readjustments are necessary unless a large change was required in the "11 meter" setting.

### 5. Calibration Against Crystals

Crystals of known frequency and accuracy in the frequency ranges  $F_{1a}$ ,  $F_{2a}$ ,  $F_{3a}$  and  $F_{4a}$  (designated in section F1) may be used in the transmitter crystal oscillator to provide standard frequency signals for the VFO calibration. The stability of the receiver local oscillator and beat frequency oscillator must be nominally good as the technique of beating the receiver BFO to the crystal and then beating the VFO signal to the receiver will be used. The receiver thus "remembers" the crystal frequency. Reduce the coupling of the receiver antenna to the minimum usable amount to avoid "pulling" of the local oscillator.

An example of calibrating the VFO using actual crystal values may be helpful. Assume that the following crystals have been found as part of the amateur station equipment: 7060 kcs., 3690 kcs. and 1980 kcs. The dial calibration points then become:

$$F_1 = \frac{7.060}{4} = 1.765 \text{ mcs.}$$

$$F_2 = 1.980 \times 1 = 1.980 \text{ mcs.}$$

$$F_3 = 7.060 \times 1 = 7.060 \text{ mcs.}$$

$$F_4 = 3.690 \times 2 = 7.380 \text{ mcs.}$$

F. 5. The receiver setting and VFO harmonic which may be used for each respective dial calibration frequency then becomes:

$$F1a = 7.060 \times 1 = 7.060 \text{ mcs.}$$

$$F2a = 1.980 \times 4 = 7.920 \text{ mcs.}$$

$$F3a = 7.060 \times 1 = 7.060 \text{ mcs.}$$

$$F4a = 3.690 \times 2 = 7.380 \text{ mcs.}$$

Proceed as follows:

- (1) Place the 1.980 mc. crystal in the C1 position of J7 (pins 3 and 5) and the 7.070 mc. crystal in the C2 position (pins 7 and 1 of J7).
- (2) Set the bandswitch on 160 or 80 meters, the VFO dial pointer on the 1.980 mc. mark, the OSCILLATOR switch on C1 position. (Leave SW8 off throughout calibration). Tune the receiver to zero beat the BFO with the crystal. Turn the OSCILLATOR switch to the VFO position and adjust the "160 hi" trimmer to zero beat the receiver BFO.
- (3) Set the VFO pointer on the 1.765 mc. mark, and the OSCILLATOR switch to the 7.060 mc. position (C2). Tune the receiver to zero beat the BFO with the crystal. Turn the OSCILLATOR switch to VFO and adjust the "160 lo" padder to zero beat the BFO. Repeat steps 2 and 3 as necessary to cancel out interaction between the "160 lo" and "160 hi" adjustments.
- (4) Remove the 1.980 mc. crystal from the C1 position and replace it with the 3.690 mc. crystal.
- (5) Set the bandswitch on 40 meters, the VFO dial pointer to 7.380 mcs. and the OSCILLATOR switch to C1. Tune the receiver to zero beat the BFO with the crystal. Turn the OSCILLATOR switch to VFO and adjust the "40 hi" trimmer to zero beat the BFO.
- (6) Set the VFO pointer on 7.060 mcs. and the OSCILLATOR switch to C2. Tune the receiver to zero beat the BFO with the crystal. Turn the OSCILLATOR switch to VFO and adjust the "40 lo" padder to zero beat the BFO. Repeat steps (5) and (6) to minimize adjustment reaction.
- (7) The 11 meter band setting may be made with a crystal which will place a harmonic signal in the 11 meter band. Set the bandswitch on 11 meters, the OSCILLATOR switch to the crystal (assume 1.810 mcs. is available) position. Zero beat the receiver BFO to 27.150 mcs. (the 15th harmonic of 1.810 mcs.). Turn the OSCILLATOR switch to VFO and adjust the "11 M" trimmer to zero beat the VFO to the receiver BFO.
- (8) Recheck the "40 hi" and "40 lo" adjustments, steps (5) and (6).

The user may think of several sources of standard signals other than those mentioned. In each case the accuracy of the source should be known before using it. Many combinations of harmonics can be found and no attempt has been made to cover all of them in this discussion. Other signal sources which may be used but are not covered here are:

- F. 5.
- (a) The signal of another amateur station whose frequency has been determined by a standard.
  - (b) The harmonics of a signal generator the output signal of which has been zero beat with a broadcast station.
  - (c) Signals of WWV discussed in the next topic.

The user must adapt his techniques to the signal source he has available.

Band edge crystals or crystals near the usual operating frequencies of the amateur stations are always valuable for occasional monitoring of the VFO signals. They may be used in a separate oscillator circuit or the crystal oscillator stage of the transmitter.

## 6. Calibration Against WWV

The following technique for calibration against the WWV 10 mc. signal is not recommended if other standard signal sources are available. It will be noted that most calibration points are on the ends of the bands. While the 160 or 80 meter calibration is accurate the 40, 20, 15 or 10 meter calibration includes the tracking error of the VFO low frequency band (160,80). The receiver, the receiver BFO and the VFO should be warmed up 1/2 hour before calibrating.

- (1) Zero beat the receiver BFO with the 10 mc. WWV signal.
- (2) Set the VFO dial pointer to 2.00 mcs., the bandswitch on 160 meters.
- (3) Adjust the "160 hi" VFO trimmer until the fifth harmonic of the VFO is zero beat with the receiver BFO.
- (4) Leaving the VFO at this setting, zero beat the receiver BFO with the seventh harmonic of the VFO (14 mcs.).
- (5) Turn the VFO to 1.75 mcs. and adjust the "160 lo" VFO padder to zero beat the eighth harmonic of the VFO with the receiver BFO.
- (6) Adjust both ends of the 160 meter band to zero beat the eighth and seventh harmonics of the VFO with the receiver BFO as necessary to cancel adjustment interaction.

### 40, 20, 15 and 10 meter calibration

- (7) Set the VFO dial at the 1.85 mc. mark and zero beat the receiver BFO to the eighth harmonic of the VFO frequency at 14.8 mcs.
- (8) Set the bandswitch to 40 meters and the dial pointer to the 7.40, 29.6 mc. mark. Zero beat the second harmonic of the VFO to the 14.8 mcs. receiver setting by adjusting the "40 hi" trimmer.
- (9) Set the bandswitch and dial pointer for 1.75 mc. VFO output again and zero beat the receiver BFO at 14 mcs. Set the bandswitch and dial for 7.0 mc. VFO output. Adjust the "40 lo" padder to zero beat the VFO second harmonic with the receiver 14.0 mc. BFO setting.

### 11 meter calibration

- (10) Set the bandswitch and VFO dial for 1.80 mc. output.
- (11) Tune the receiver to 27 mcs. and zero beat the receiver BFO to the fifteenth harmonic of the VFO.
- (12) Set the bandswitch on 11 and the dial pointer on 27.0 mcs. Adjust the "11 meter trimmer to zero beat the fourth harmonic of the VFO to the receiver BFO setting.

## F. 7. Calibration Trouble Shooting

If the VFO frequency cannot be adjusted to the dial markings due to apparent lack of trimmer or padder range.

Check to make certain the frequency standard used is accurate (crystals used in amateur service are often found to differ from their marked frequency due to holder conditions, oscillator circuit loading or non-critical original calibration).

Make certain image frequencies are not being mistaken for desired frequencies in the receiver.

If, after checking the frequency standard and receiver settings, the VFO frequency cannot be adjusted to chosen dial marks, adjust the trimmers to bring the VFO as close as possible to correct calibration. Remove the VFO side cover and recheck the dial location relative to the tuning capacitor shaft. The VFO tuning capacitor should be exactly meshed (not necessarily the stop position) when the dial pointer precisely horizontal to the left. If the dial requires re-positioning, loosen the two set screws in the shaft coupler attached to C1 from beneath the chassis, re-set the dial, tighten both set screws. This should permit the VFO to be calibrated properly.

## G. TROUBLE SHOOTING

1. Operational problems may be due either to tube failure, component failure or improper operational technique.

Frequently, malfunction of a piece of equipment such as the Valiant is the result of a tube failure. Meter readings will usually indicate the probable stage affected and servicing requires only substitution of known good tubes. In any case, tubes should be tested first and eliminated as the source of trouble.

As a rule, a component failure in a piece of equipment such as the Viking Valiant will produce more than one abnormal value of current or voltage or both. The effect of a component failure will usually be noticed on more than one meter reading and in more than one stage of the transmitter. Portions of each circuit are almost invariably common to another circuit and this factor should be noted for analyzing troubles for speedy systematic servicing.

For example, suppose that the meter M1 in the "oscillator" position reads almost zero current. "Buffer" current reading is low but probably due to the fact that the buffer is receiving no excitation. There is no grid current to the final amplifier but this is to be expected since the crystal/buffer stage (V3) appears not to be functioning. Listening carefully on the receiver reveals that the VFO is oscillating. Under these conditions, the common factor would appear to be the source of plate or screen voltage for either V1 or V3. Since the socket XV1 is not readily accessible and since there must be voltage at each end of R5 (it was determined V1 is oscillating) then it would be wise to assume that the VFO is normal until all the easier checks have been made. A voltage check at pin 3 or 8 of V3 shows the screen voltage to be zero. A check of components would reveal that R8 (68K ohms) is burned out, caused by V3 being shorted, C27 shorted or an accidental ground of pin 3 or 8 of socket XV3.

To service the equipment make liberal use of current values, normal voltage readings and resistance measurements appearing in this manual. Use these values in the order stated. Abnormal dial readings may be used to analyze difficulties in RF circuits. Make the each checks first, look first for simple faults but remember that a component failure often produces a second collateral component failure and to restore normal operation both must be remedied.

G. 2. Operating Problems and Possible Remedies

- |   |   |
|---|---|
| "Zero" OSCILLATOR switch position blocks receiver | - - SW8 in "man" position   |
| RF Section dead                                   | - - P8 disconnected   |
| Hum on Carrier                                    | - - defective preamplifier tubes<br>microphone shield not grounded  |
| Antenna will not load                             | - - review section E5   |
| TVI   | - - review section E7   |
| Poor audio quality                                | - - CLIPPING control in extreme<br>CCW position (max clipping)  |
| VFO unstable                                      | - - marginal setting of keying<br>pot R39   |
| Crystal oscillator inoperative                    | - - crystals plugged into wrong<br>socket pins, C1, pins 3 & 5<br>of J7, C2 pins 7 & 1 of J7  |
| Modulator tubes run red                           | - - check bias adjustment<br>check for RF on cabinet causing<br>feedback  |
| Modulator current swing too low                   | - - Excessive bias<br>Defective audio or modulator<br>tube<br>RF feedback saturating modulator  |
| Reverse grid current                              | - - Excessive drive to final<br>amplifier tubes   |
| Low final amplifier plate current                 | - - Clamper adjusted incorrectly<br>Incorrect bias adjustment<br>Mode switch on SSB<br>Low grid drive<br>One or more 6146s not lighting |

TABLE 1

## VIKING VALIANT TRANSMITTER SOCKET VOLTAGES

Line Voltage	117V	Final Plate	- 330 ma.
Mode-AM Phone	(no audio signal)	Final Grid	- 8.0 ma.
RF Load	50 ohms	RF Output Freq.	- 7.0 mcs.
		H.V. D.C.	- 630V Mod.
		H.V. D.C.	- 620V Final Amp (Measure at term. 3 of TS18)

Tube Socket	Tube Socket Pin Number								
	1	2	3	4	5	6	7	8	9
XV1				(See note 1)					
XV2				(See note 1)					
XV3	7.1	NC	120	5.7AC	-	330	-	NC	-
XV4	330	8.9	-	5.9AC	-	55	9.6	-11	NC
XV5	-	5.95AC	152	-	-70 <sup>a</sup>	-	-	-	-
XV6	-	5.95AC	152	-	-70 <sup>a</sup>	-	-	-	-
XV7	-	5.95AC	152	-	-70 <sup>a</sup>	-	-	-	-
XV8	NC	0	-	5.95AC	146	146	-6.5		
XV9	NC	0	220	NC	106	NC	108	NC	
XV10	NC	105	110	NC	217	NC	108	NC	
XV11	-.65	-17	18	-	-	330	0	18	5.8AC
XV12	95	-.5	-	-	-	182	0	1.2	6.0AC
XV13	20	19.5	-	6.0AC	20	80	19.5		
XV14	170	NC	-	6.0AC	165	0	7.5		
XV15	330	0	14	-	-	330	0	14	6.0AC
XV16	0	6.2AC	218	NC	-46	NC	-	NC	
XV17	0	6.2AC	218	NC	-46	NC	--	NC	
XV18	675	625	330	675					
XV19	675	NC	0	675	NC				
XV20	NC	370	340	305AC		305AC	NC	370	
XV21	210AC	6.2AC	NC	-262	-262	-235	0	210AC	

a - Measure at junction of L7 and R57  
 - Ground to chassis  
 NC No connection

Note 1: Because XV1 and XV2 are not readily accessible, voltages are listed for terminal strip TS6 underneath the VF0.

Terminal	Voltage
1	-8
2	5.8AC
3	.05
4	0
5	5.8AC
6	340
7	.05
8	0

Voltage tolerance, plus or minus 20%  
 Measured with 20K ohms/V meter

TABLE 2

## VIKING VALIANT TRANSMITTER RESISTANCE MEASUREMENTS\*

Tube Socket	Tube Socket Pin number								
	1	2	3	4	5	6	7	8	9
XV1				(See note 1)					
XV2				(See note 1)					
XV3	430	NC	80K	.05	-	12.5K	-	NC	33K
XV4	12K	450	-	.05	-	6500	500	70K	NC
XV5	-	.05	50K	-	2700	-	-	-	-
XV6	-	.05	50K	-	2700	-	-	-	-
XV7	-	.05	50K	-	2700	-	-	-	-
XV8	NC	.3	-	.05	50K	50K	200K		
XV9	NC	-	11K	NC	Infinite	NC	11K	NC	
XV10	NC	Infinite	11K	NC	50K	NC	11K	NC	
XV11	2500	1.1 meg.	35K	-	-	12K	50K	35K	.05
XV12	300K	1 meg.	-	-	-	110K	1 meg	700	.05
XV13	270K	350K	-	.05	220K	12K	350K		
XV14	70K	NC	-	.1	70K	100K	2200		
XV15	12.5K	140K	900	-	-	12.5K	140K	900	.05
XV16	.65	0	50K	NC	2300	NC	-	NC	
XV17	.65	0	50K	NC	2300	NC	-	NC	
XV18	40K	40K	20K	40K					
XV19	40K	NC	.2	40K					
XV20	NC	13K	13K	58	NC	60	NC	13K	
XV21	37	0	NC	12K	12K	11K	0	38	

Note 1: Since XV1 and XV2 are not readily accessible, resistance to ground for terminals of terminal strip TS6 are listed:

<u>Terminal</u>	<u>Resistance</u>	<u>Terminal</u>	<u>Resistance</u>
1	23K	5	.7
2	.1	6	14K
3	2.25	7	2.25
4	6.5	8	32K

\* approximate values resistance to chassis, may vary plus or minus 20%

- grounded to chassis

NC no connection

TABLE 3

## TRANSFORMER AND CHOKE MEASUREMENTS

	<u>Leads</u>	<u>Open Circuit Voltages</u>	<u>Resistance (Ohms)</u>
T1 - 22.1283	HIGH VOLTAGE TRANSFORMER		
	Red to Red Yellow	760 V AC	50
	Red to Red Yellow	760 V AC	50
	Red to Red		100
	Black to Black		.5
T2 - 22.1282	LOW VOLTAGE TRANSFORMER		
	Blue to Red Yellow	215 V AC	40
	Blue to Red Yellow	215 V AC	40
	Blue to Blue		80
	Red to Red Yellow	310 V AC	65
	Red to Red Yellow	310 V AC	65
	Black to Black		1.4
	Brown to Brown	2.6 V	.05
	Green to Green	6.8 V	.05
	Yellow to Yellow	5.4 V	.2
T3 - 22.1285	MODULATION TRANSFORMER		
	Blue to Brown		90
	Blue to Red		45
	Brown to Red		45
	Yellow to Red Yellow		18
	Green to Green Yellow		18
T4 - 22.1286	DRIVER TRANSFORMER		
	Red to Blue		230
	Green to Yellow		800
L43 - 22.1284	H. V. CHOKE		
	Black to Black		45
L44 - 22.749	LOW VOLTAGE CHOKE		
	Black to Black		300
L45 - 22.1247	AUDIO REACTOR		
	Black to Black		900

TABLE 4

## VIKING VALIANT TRANSMITTER - TYPICAL DIAL SETTINGS\*

CW MODE

OSCILLATOR - VFO Plate - 450 ma.  
 LOAD - 50 ohms (resistive) Grid - 8.0 ma.

<u>Frequency</u>	<u>Band</u>	<u>Exciter</u>	<u>Final</u>	<u>Aux</u>	<u>Coupling</u>	<u>Fine</u>	<u>Drive</u>
1.80 mcs.	160	48	72	10	1	1	1
3.55 mcs.	80	38	10	4		7	2
7.1 mcs.	40	56	26	7		6	4
14.1 mcs.	20	54	20	9		6	6.5
21.15 mcs.	15	78	48	10		4	6.5
28.2 mcs.	10	68	60	10		5.5	6
27.0 mcs.	11	56	56	10		5	9

AM MODE

OSCILLATOR - VFO Plate - 330 ma.  
 LOAD - 50 ohms (resistive) Grid - 8.0 ma.

<u>Frequency</u>	<u>Band</u>	<u>Exciter</u>	<u>Final</u>	<u>Aux</u>	<u>Coupling</u>	<u>Fine</u>	<u>Drive</u>
1.80 mcs.	160	54	40	3		2	1.5
3.55 mcs.	80	38	22	2		0	3
7.1 mcs.	40	60	36	6		6	2
14.1 mcs.	20	54	30	9		3	6
21.15 mcs.	15	78	52	10		3	7
28.2 mcs.	10	78	68	10		5	7
27.0 mcs.	11	56	62	10		4	7

\* To be used only for rough approximations of correct tuning.

VIKING VALIANT TRANSMITTER

Parts List

<u>Part No. or Drawing No.</u>	<u>Item No.</u>	<u>Qty.</u>	<u>Description</u>
16.1001-4	Bkt. 1,2, 3,4,5	5	Topchassis component mounting brackets
16.1001-5	Bkt. 6	1	Underchassis component mounting brackets
16.1165-1	Bkt. 7	1	Underchassis bandswitch bracket
16.1167-2	Bkt. 8,9, 10,11,12	5	VFO cond. brackets
22.1182-2	Bkt. 13	1	Meter shield bracket
16.82-23	Bkt. 14	1	L bracket, plate blocking condenser
169-26	C1A, B	1	Special LA dual variable condenser
160-107-24	C2, 5	2	15ML1 variable condenser
160-107-1	C4	1	15ML1 variable condenser
160-130-1	C6, C3	2	30M8 variable condenser
149-3-3	C7	1	50R12 variable condenser
149-530-3	C8A, B	1	120RD18 variable condenser
149-13-3	C9	1	360R12 variable condenser
22.806	C10	1	47 2 1/2% mmf N220 500 V ceramic condenser
22.954	C11	1	62 2 1/2% mmf NPO 500 V ceramic condenser
22.804	C12,13,76,81	4	500 2% mmf 500V silver mica condenser
22.805	C14,15,35, 94,95	5	1000 2% mmf 500 V silver mica condenser
22.809	C16	1	91 2 1/2% mmf N080 ceramic condenser
22.823	C17	1	140 2 1/2% mmf NPO 500 V ceramic condenser
22.807	C18	1	43 2 1/2% mmf NPO 500 V ceramic condenser
22.827	C19,20,21, 25,26,27,28, 30,31,33,34, 36,49,50,51, 52,53,57,58, 59,60,61,62, 63,66,67,68, 70,71,72,73 87,88,86,64,65	36	.005 mfd 600 V GMV ceramic condenser
22.774	C22,77	2	300 mmf 500 V 20% mica condenser
22.777	C23,96,97	3	25 mmf 500 V 5% silver mica condenser
22.862	C24, 80	2	200 mmf 500 V 20% mica condenser
22.776	C29	1	50 mmf 500 V 5% silver mica condenser
22.836	C37	1	2000 mfd 1.5 KV trans. type condenser
22.957	C38A,B,C,D	4	150 mmf 500 V 5% silver mica condenser
22.1297	C39A,B,C	4	330 mmf 500 V 5% silver mica condenser
22.1316	C42,A,B,C,D	1	600,900,1200 mmf special mica condenser
22.772	C41	1	300 mmf 1200 V mica condenser
22.826	C47,48	2	.01 mfd 1500 V ceramic condenser
22.956	C54,55,56,46	4	.002 mfd 1500 V ceramic condenser
167-701-2	C74	1	10L50 neut. condenser
22.1097	C90,79,83,84	4	.01 +80 -20% mfd ceramic disc condenser
22.768	C82,85,78,89, 100	5	.1 mfd 400 WV paper condenser
22.1298	C91,92	2	80 mfd 450 V electrolytic condenser

## Parts List

Page 2

<u>Part No. or Drawing No.</u>	<u>Item No.</u>	<u>Qty.</u>	<u>Description</u>
22.1299	C92A, B	1	15-15 mfd 350 V electrolytic condenser
22.764	C98A, B	1	15-15 mfd 450 V electrolytic condenser
22.763	C99	1	10 mfd 25 V electrolytic condenser
22.828	C40	1	.001 mfd 1.5 KV ceramic condenser
22.856	C75	1	10 mmf 500 V 5% silver mica condenser
22.857	C101	1	100 mmf 500 V 5% silver mica condenser
17.990	CH1	1	Chassis
23.1128-2	CH2	1	Cabinet
23.1193-3	CH3	1	Panel
17.853-2	CH4	2	Chassis rails
17.820	CH5	1	VFO top
17.819	CH6	1	VFO side plate
18.699	CH7	1	VFO phenolic plate
17.855	CH8	1	VFO sub-chassis
22.825	CH9	4	Bumper feet
71.43-097	CH10	65"	3/16" round Metaltex gasket
23.1059	D1	1	Drive arm for VFO switch
14.504	D2	1	Drive cam for VFO switch
23.1062	D3	1	Planetary drive assembly
17.858-3	D4	1	Dial escutcheon
22.993-2	D5	1	Dial plate
22.994	D6	26"	Rubber gasket
22.995	D7	4"	Rubber light blocks
23.1064	D8	1	Dial pointer
23.564-56	D9A-B	2	Red jewels
13.123-12	D22	5	3/8"-32 panel bearings
13.760-2	D23	3	Couplings (less set screws)
13.155-4	D24	2	VFO sub-chassis spacer
14.31-62	D25	2	1 3/8" crystal socket spacer
14.31-64	D27	4	2 1/8" VFO chassis rods
14.31-65	D28	4	2 15/16" VFO chassis rods
14.139-2	D30	1	6 7/16" ext. shaft
14.139-1	D31	1	5 5/16" ext. shaft
18.638-2	D32	5	VFO trimmer shafts
14.139-4	D33	1	8 1/8" ext. shaft
23.907-22	D34	2	100-0 knob
23.1007-5	D35	8	Phenolic knob
23.980-12	D36	1	1 5/8" band knob
23.1060	D37	1	Crystal knob cover
32.46-13	D38	1	2 3/8" maroon knob
104-264-3	D39	1	Insulated shaft coupler
13.155-114	D40	2	Spacers 11/16"
13.155-87	D41	1	Spacer 7/16"
18.36-7	E1	2	5/8" O.D. x 17/64" I.D. x 3/8" fiber shoulder bushing
22.1309	E6	1	83-765 hood UG-177/U
16.35-1	E8-12	5	Tube caps
16.51-5	E13,14	2	Tube caps

## Parts List

Page 3

<u>Part No. or Drawing No.</u>	<u>Item No.</u>	<u>Qty.</u>	<u>Description</u>
10.55-2	E15	1	Ceramic post insulator
10.19-2	E16	1	Cone insulator 1 1/2"
10.19-3	E17	1	Cone insulator 2"
16.1282	E18	1	Plate connector strap
22.950	E19	1	Coil fastener
22.1311	F1	1	1 1/2 amp fuse - Slo-Blow
22.840	F2, 3	2	8 amp fuse
22.1094	FH1	1	Fuse holder
22.113-1	G1-9	9	Grommet
22.113-5	G10	1	Grommet
23.1201	H1	1	Harness
			#4 hardware envelope
			#6 hardware envelope
			#8 hardware envelope
			#10 hardware envelope
22.377	I1, I2	2	#51 pilot lamps
22.21	I3	1	6S6 117 V lamp
22.979	J1	1	Mic. jack
22.1246	J2	1	Single closed circuit jack
22.1096	J3	1	Single phono jack
126-105	J4	1	Relay jack
22.746	J5, 6	2	83-1R coax. receptacles
22.849-2	J7	1	Octal socket
22.977	J8	1	9 pin mica filled socket, octal style
23.968-2	L1A, B	1	Dual VFO coil
22.844-2	L2, 41	2	52 uh rf choke
22.1193	L3, 4, 7, 14 15, 40	6	2.4 mh rf choke
22.949-2	L5	1	Oscillator coil
23.902-13	L6A	1	LF buffer coil
23.913-2	L6B	1	HF buffer coil
23.912-3	L8, 9, 10	3	Plate parasitic suppressors
102-754-2	L11	1	#754 choke
23.1000	L12-18	2	4.7 uh rf choke
23.1202	L13A	1	Final tank coil
23.1203	L13B	1	Final aux. tank coil
23.1204	L17	1	VFO output coil variable
22.844	L19	1	RF choke (single pi) 200 uh
22.844-3	L20	1	RF choke 125 uh
23.902-12	L39	1	160 meter aux. coil
22.1284	L43	1	High voltage choke
22.749	L44	1	Low voltage choke
22.1247	L45	1	Audio reactor
22.1168	M1	1	Meter
22.1095	P3	1	Single phono plug
23.1031	P4	1	Relay plug
22.981	P9	1	Fused power plug
22.978	P8	1	9 pin plug

## Parts List

Page 4

<u>Part No. or Drawing No.</u>	<u>Item No.</u>	<u>Qty.</u>	<u>Description</u>
22.572	R1,37	2	100K 1/2 watt carbon resistor 10%
22.965	R2	1	56 ohm 1/2 watt carbon resistor 10%
22.803	R3,20,41	3	18K 2 watt carbon resistor 10%
22.722	R4	1	1.5 K 1/2 watt carbon resistor 10%
22.801	R5,6,60	3	470 ohm 1/2 watt carbon resistor 10%
22.719	R7,25,40	3	1 meg 1/2 watt carbon resistor 10%
22.853	R8	1	68K 1 watt carbon resistor 10%
22.1287	R9	1	15K 1/2 watt carbon resistor 10%
22.1047	R10,54	2	100 ohm 2 watt carbon resistor 10%
22.576	R11,12	2	33K 1/2 watt carbon resistor 10%
22.832	R13	1	1 meg 1/2 watt potentiometer
22.718	R14	1	470K 1/2 watt carbon resistor 10%
22.1288	R15	1	12K 25 watt wire wound resistor 5%
22.1310	R16	1	12K 50 watt fixed WW resistor
22.1099	R17,18	2	20K 10 watt wire wound resistor
22.1306	R19	1	15K $\pm$ 10% 10 watt resistor
<del>22.1289</del> 22.1373	R22	1	75K 25 watt adjustable wire wound resistor
22.1293	R23	1	9K 7 watt resistor 10%
22.239	R36	1	10K 1/2 watt carbon resistor 10%
22.802	R24	1	4.7 K 1/2 watt carbon resistor 10%
22.1195	R28	1	1 meg 1/4 watt log taper potentiometer
22.1202	R29	1	680 ohm 1/4 watt carbon resistor 10%
22.967	R31,53	2	220K 1/2 watt carbon resistor 10%
22.1290	R34	1	100K 2 watt linear taper potentiometer
22.717	R26,30,35,52	4	47K 1/2 watt carbon resistor 10%
22.716	R38	1	22K 1/2 watt carbon resistor 10%
22.1115	R39	1	100K 1/2 watt linear potentiometer
22.968	R43	1	150K 1/2 watt carbon resistor 10%
22.882	R44	1	2.2K 1/2 watt carbon resistor 10%
22.969	R45	1	820 ohm 1/2 watt carbon resistor 10%
22.830	R46,47	2	100 ohm 1/2 watt carbon resistor 10%
22.713	R48,49	2	22 ohm 1/2 watt carbon resistor 10%
22.1331	R50	1	1000 ohm 2 watt carbon resistor 10%
22.732	R51	1	25K 4 watt wire wound potentiometer
22.864	R55,56	2	2.2 ohm 5% shunt
22.711	R57	1	5.1 ohm 5% shunt
23.914-1	R58	1	100 mv. shunt for 500 ma.
23.914-2	R59	1	Shunt for 250 ma.
22.1305	R32	1	270K 1/2 watt carbon resistor 10%
22.1113	R33	1	330K 1/2 watt carbon resistor 10%
22.1330	R42	1	47K 1 watt carbon resistor 10%
22.1307	RY1	1	Relay DPST N.O. relay
17.981	SH1	1	Final shield
17.846	SH2	1	VFO shield
22.1181-2	SH3	1	Meter shield
17.980	SH4	1	Mic. and key shield
17.857	SH5	1	Buffer shield
22.948-2	SH6	1	Socket shield

## Parts List

Page 5

<u>Part No. or Drawing No.</u>	<u>Item No.</u>	<u>Qty.</u>	<u>Description</u>
22.988	SW1	1	VFO bandswitch
22.989	SW2	1	VFO crystal switch
22.1296	SW3	1	Bandswitch
22.1295	SW4	1	Mode switch
22.847-2	SW5	1	Meter switch
22.1308	SW6	1	Coupling switch
22.755	SW7, 8	2	SPST toggle switch
22.1283	T1	1	High voltage plate transformer
22.1282	T2	1	L.V. power transformer
22.1285	T3	1	Mod. transformer
22.1286	T4	1	Driver transformer
22.740-6	TS1,10,25	3	6 lug terminal strip
22.740-8	TS6	1	8 lug terminal strip
22.740-3	TS8,15,16, 17,32,27,49	7	3 lug terminal strip
22.740-7	TS12,48	2	7 lug terminal strip
22.740-4	TS13,18,33	3	4 lug terminal strip
22.740-2	TS19	1	2 lug terminal strip
22.740-11	TS20	1	11 lug terminal strip
22.837	TS50,51	2	2 lug terminal strip
22.780	V1	1	6AU6 electron tube
22.787	V2	1	0A2 electron tube
22.1118	V3	1	6CL6 electron tube
22.1248	V4	1	5763 electron tube
22.788	V5,6,7,16,17	5	6146 electron tube
22.781	V8	1	6AQ5 electron tube
22.1110	V9,10	2	VR-105/0G3 electron tube
22.916	V11,15	2	12AU7 tube
22.915	V12	1	12AX7 electron tube
22.786	V13	1	6AL5 electron tube
22.1249	V14	1	6C4 electron tube
22.212	V18,19	2	866A electron tube
22.791	V20	1	5V4 electron tube
22.1332	V21	1	6BY5-GA electron tube
71.91-100	W1	16 ft.	#20 black plastic covered tinned copper wire
71.91-102	W2	7 ft.	#20 red plastic covered tinned copper wire
71.91-103	W3	2 ft.	#20 orange plastic covered tinned copper wire
71.91-104	W4	2 ft.	#20 yellow plastic covered tinned copper wire
71.91-105	W5	7 ft.	#20 green plastic covered tinned copper wire
71.91-106	W6	3 ft.	#20 blue plastic covered tinned copper wire
71.27-115	W7	10 ft.	#16 bare tinned copper wire
71.13-125	W8	40 ft.	#18 formex or nylalad copper wire
71.49-114	W9	7 ft.	Black line cord 18-2 POSJ type
22.997	W10	1/2 ft.	3/8 round wood dowel
71.32-178	W12	10"	RG59/U coaxial cable
42.24-050	W13	1 ft.	.053 I.D. varnished tubing
42.24-107	W14	1/2 ft.	.133 I.D. varnished tubing

Parts List

Page 6

<u>Part No. or Drawing No.</u>	<u>Item No.</u>	<u>Qty.</u>	<u>Description</u>
42.24-113	W15	1/2 ft.	.208 I.D. black vinylite tubing
71.49-107	W16	3 ft.	HV wire
42.24-112	W17	1/3 ft.	#5 .187 I.D. vinylite tubing, white
42.24-105	W19	1/2 ft.	#10 .106 I.D. extruded black tubing XTE-30
22.984	XI1,2	2	Lamp socket shell
29.319-1	XI1,2	4	Lamp socket contact button washer
16.772	XI1,2	2	Lamp socket spring
23.631	XI3	1	Socket assembly candelabra screw base
22.975	XV1,2,8,13,14	5	7 pin min. mica filled socket
22.976	XV3,4,11,12,15	5	9 pin min. mica filled socket
22.1274	XV5,6,7,9, 10,16,17,20,21	9	8 pin octal mica filled socket
22.1223	XV18,19	2	4 pin socket

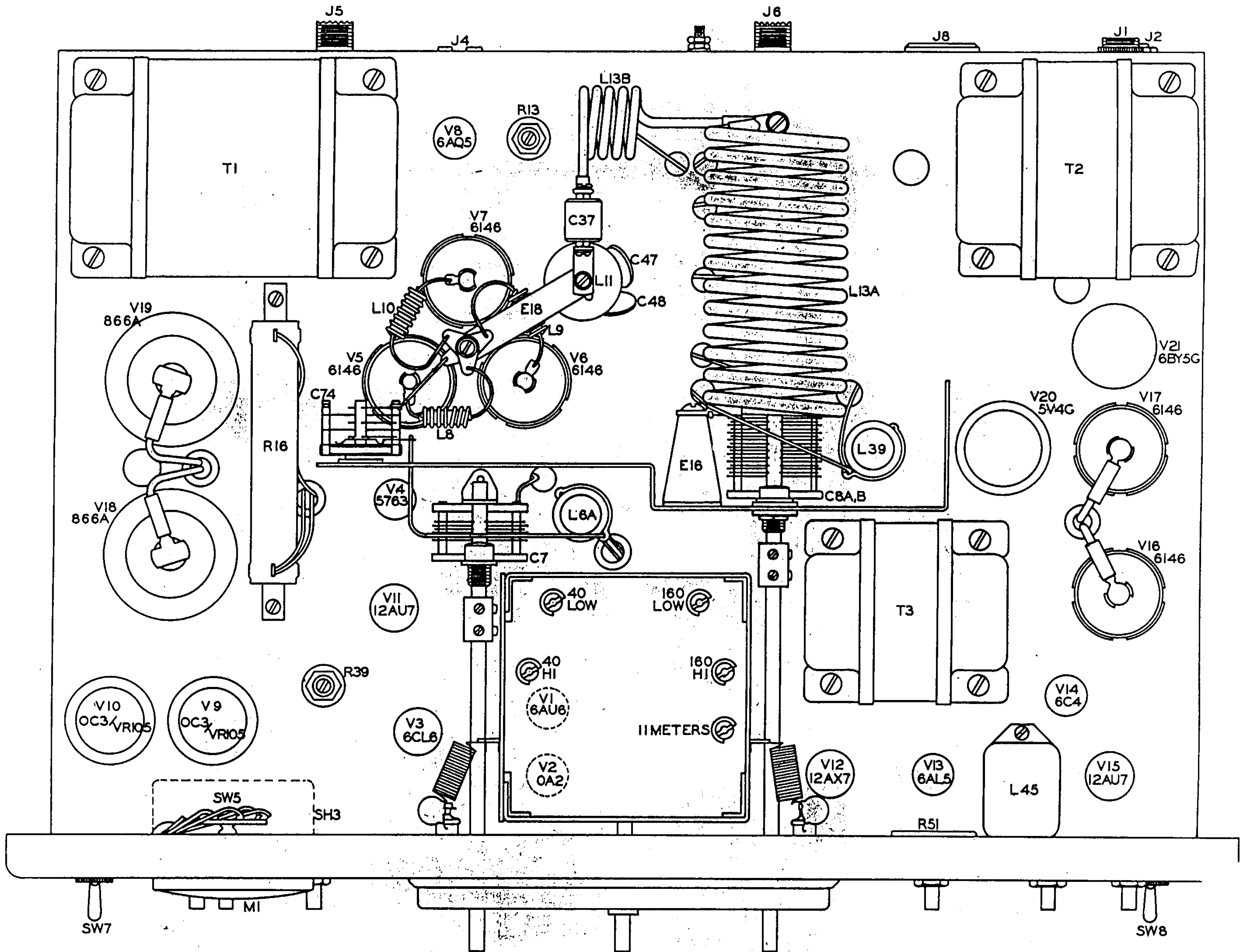

Figure 1, Valiant Tube Layout Guide

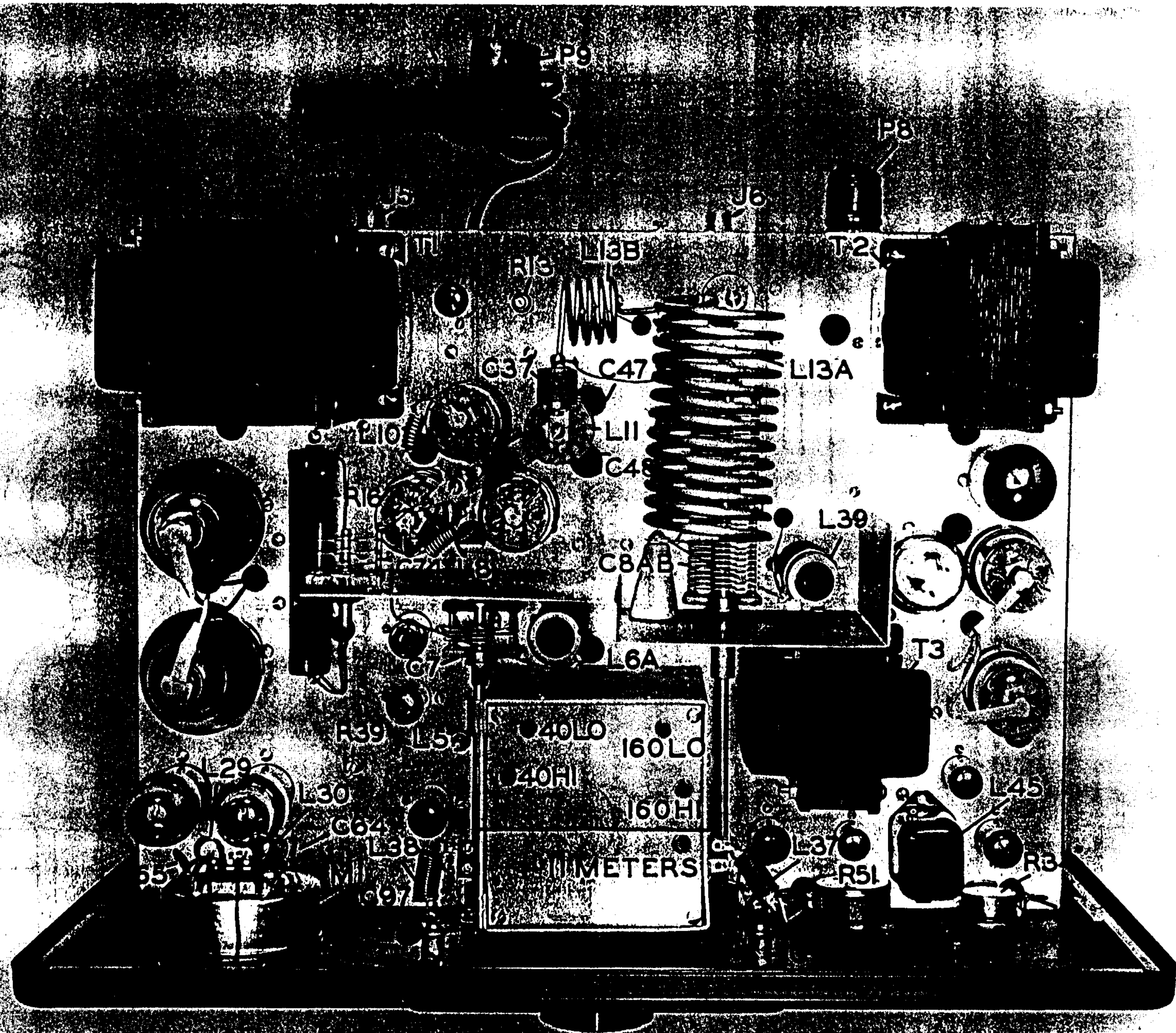

Figure 2, Valiant, Top View

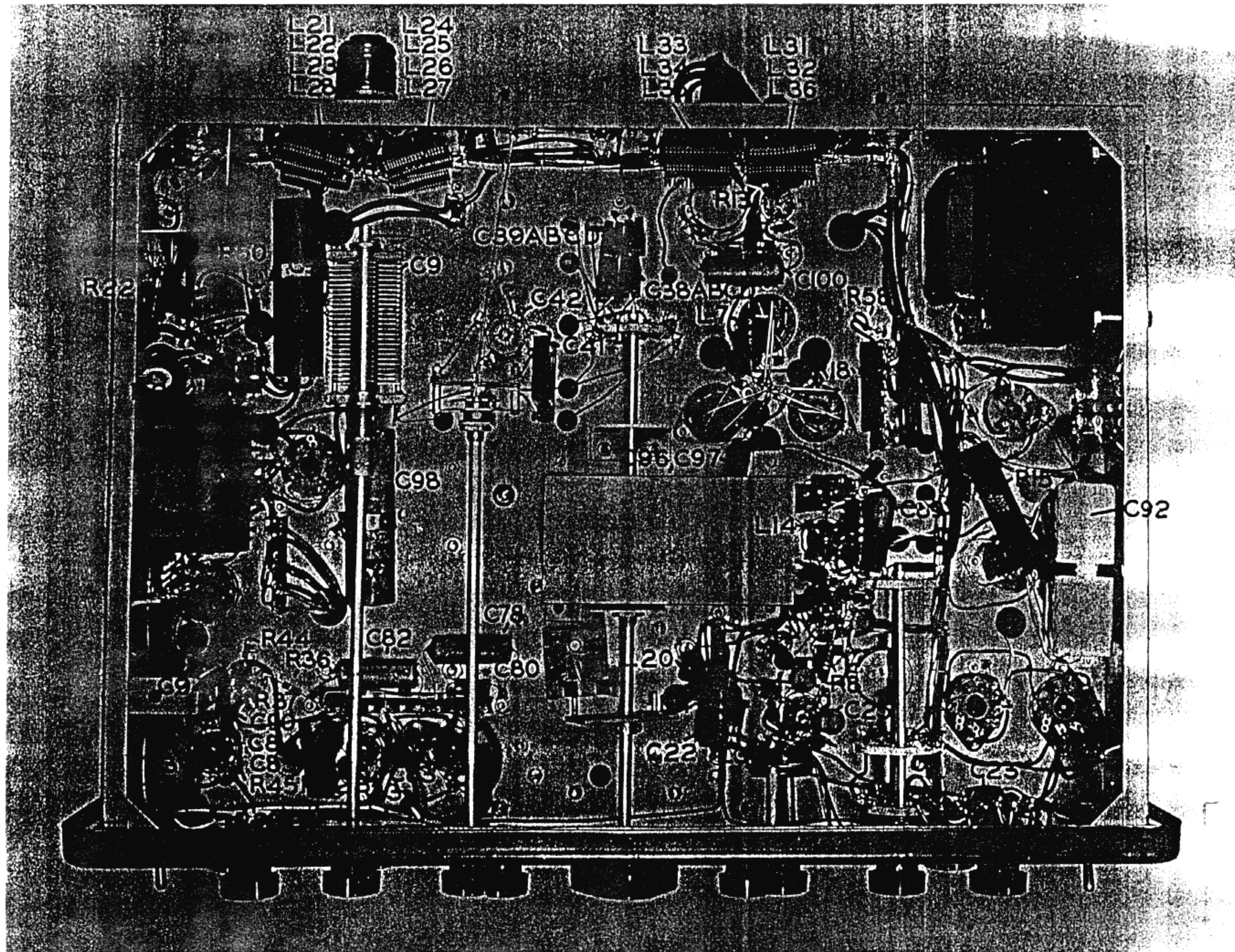

Figure 3, Valiant, Bottom View

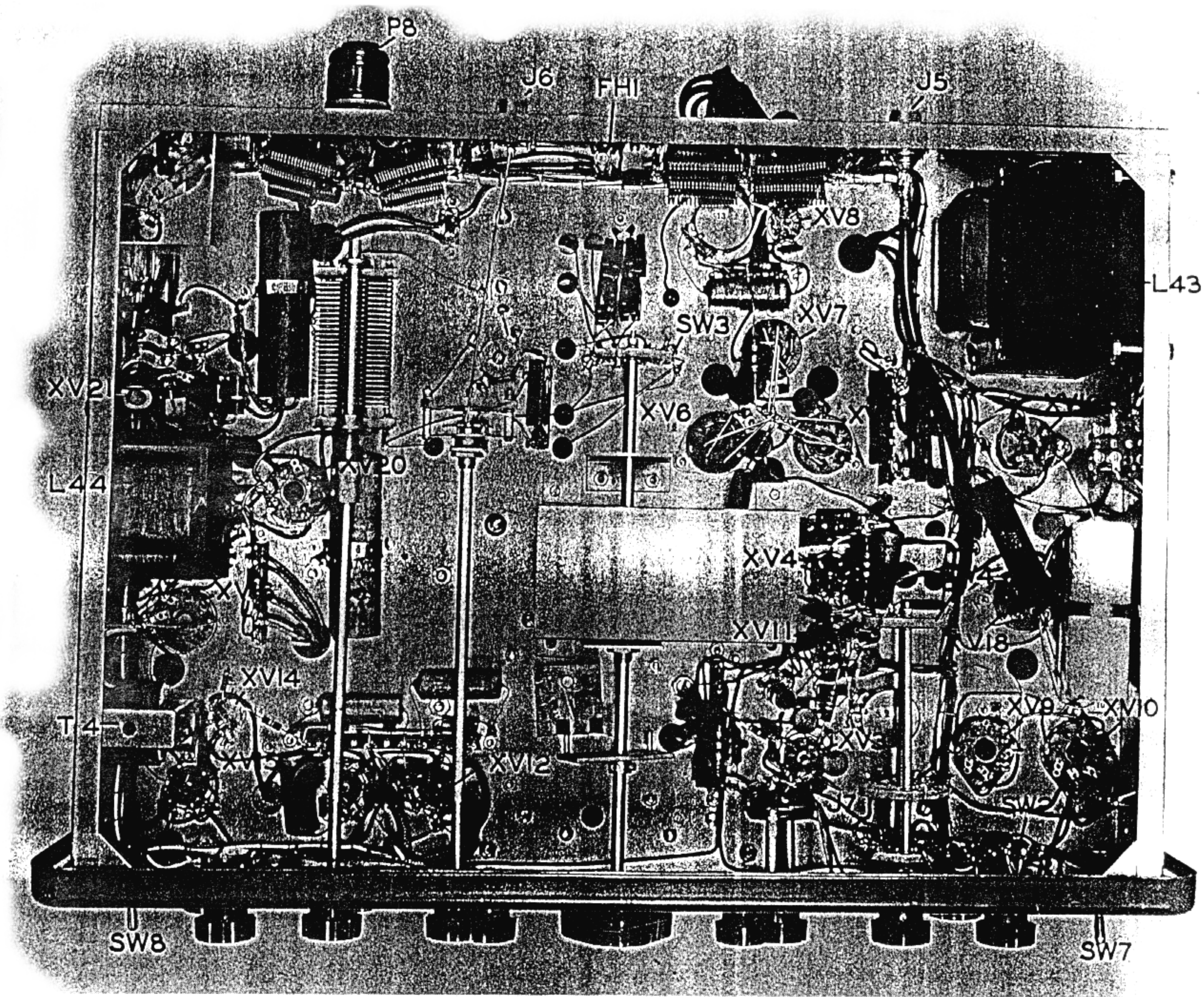

Figure 4, Valiant, Bottom View

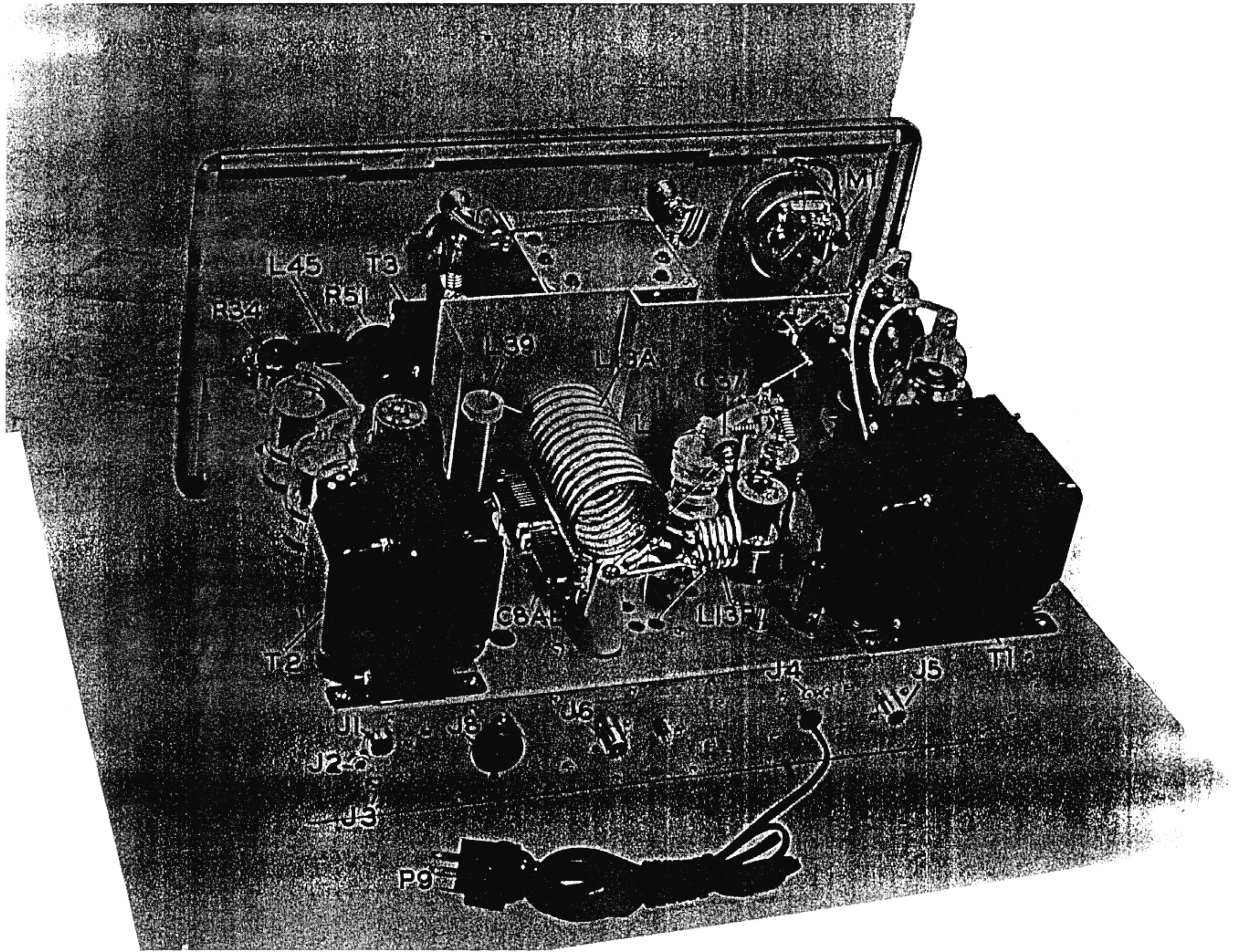

Figure 5, Valiant, Rear View

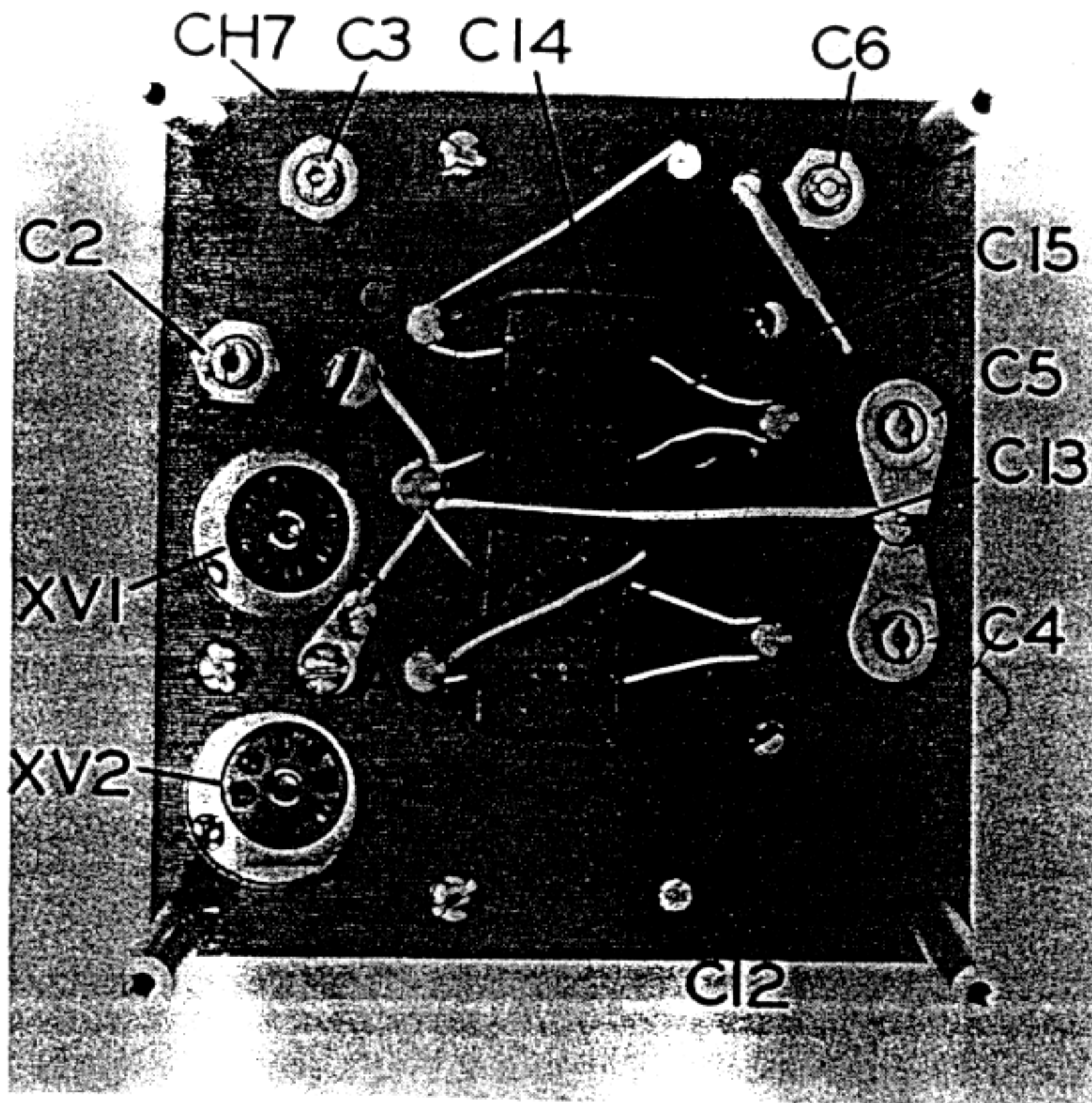

Figure 6a, VFO Chassis, Top View

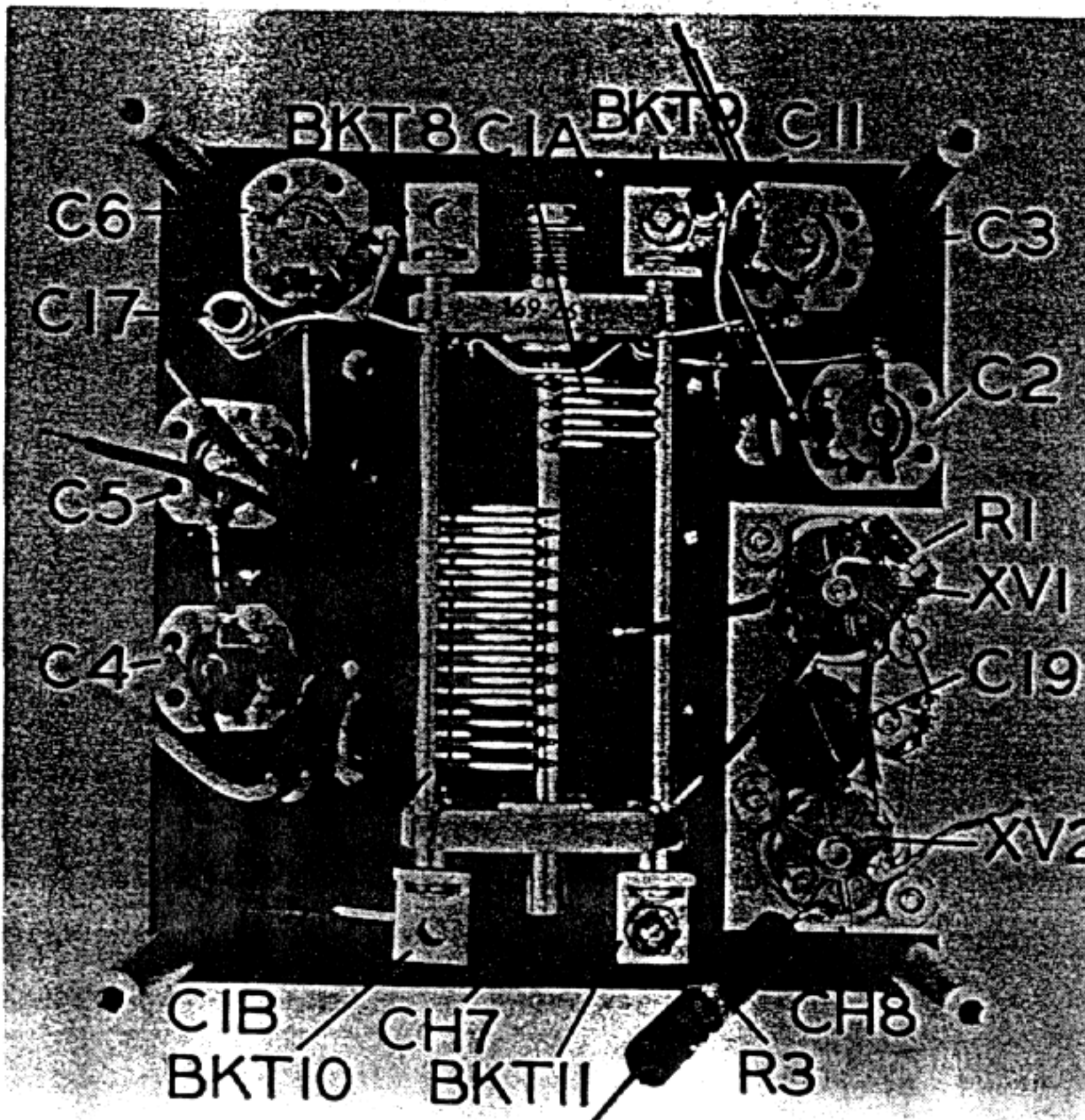

Figure 6b, VFO Chassis, Bottom View

TUBE SOCKET CONNECTIONS BOTTOM VIEW

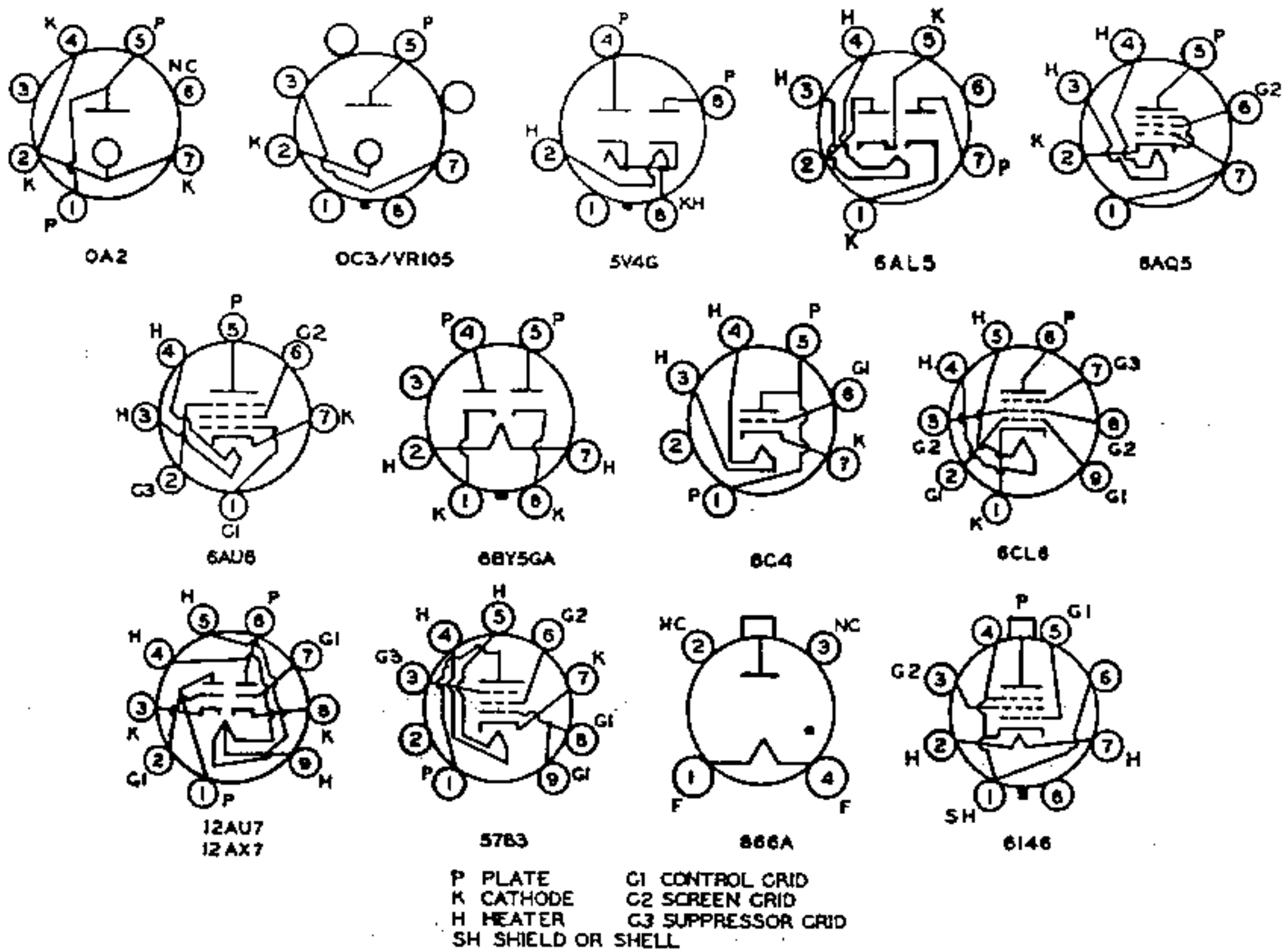

Figure 7a

CONDENSER-RESISTOR COLOR CODE

COLOR	SIGNIFICANT FIGURE	DECIMAL MULTIPLIER	TOLERANCE (%)	VOLTAGE RATING*
BLACK	0	1	—	—
BROWN	1	10	1	100
RED	2	100	2	200
ORANGE	3	1,000	3	300
YELLOW	4	10,000	4	400
GREEN	5	100,000	5	500
BLUE	6	1,000,000	6	600
VIOLET	7	10,000,000	7	700
GRAY	8	100,000,000	8	800
WHITE	9	1,000,000,000	9	900
GOLD	—	0.1	5	1,000
SILVER	—	0.01	10	2,000
NO COLOR	—	—	20	500

\* APPLIES TO CONDENSERS ONLY



**COLOR CODING OF FIXED RESISTORS**  
**A**—FIRST SIGNIFICANT FIGURE OF RESISTANCE IN OHMS  
**B**—SECOND SIGNIFICANT FIGURE  
**C**—DECIMAL MULTIPLIER  
**D**—RESISTANCE TOLERANCE IN PERCENT IF NO COLOR SHOWN TOLERANCE 15±20%.

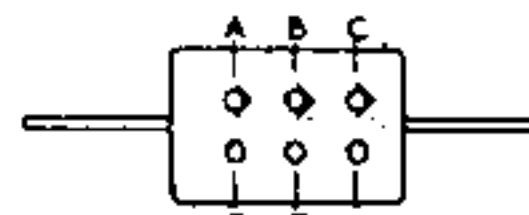

JAN FIXED CAPACITORS

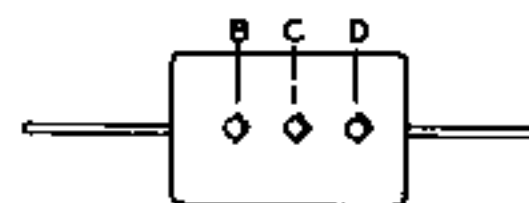

RMA 3-DOT CODE 500VOLT±20%

**COLOR CODING OF FIXED CONDENSERS**  
**A**—TYPE: MICA BLACK, PAPER SILVER  
**B**—FIRST SIGNIFICANT FIGURE OF CAPACITY  
**C**—SECOND SIGNIFICANT FIGURE  
**D**—DECIMAL MULTIPLIER  
**E**—TOLERANCE  
**F**—CHARACTERISTIC  
**G**—THIRD SIGNIFICANT FIGURE  
**H**—VOLTAGE RATING

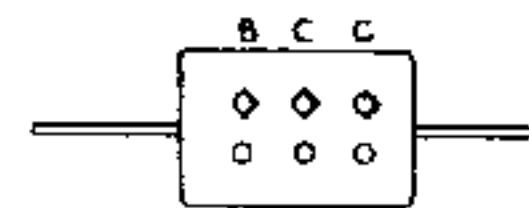

RMA 8-DOT CODE

Figure 7b

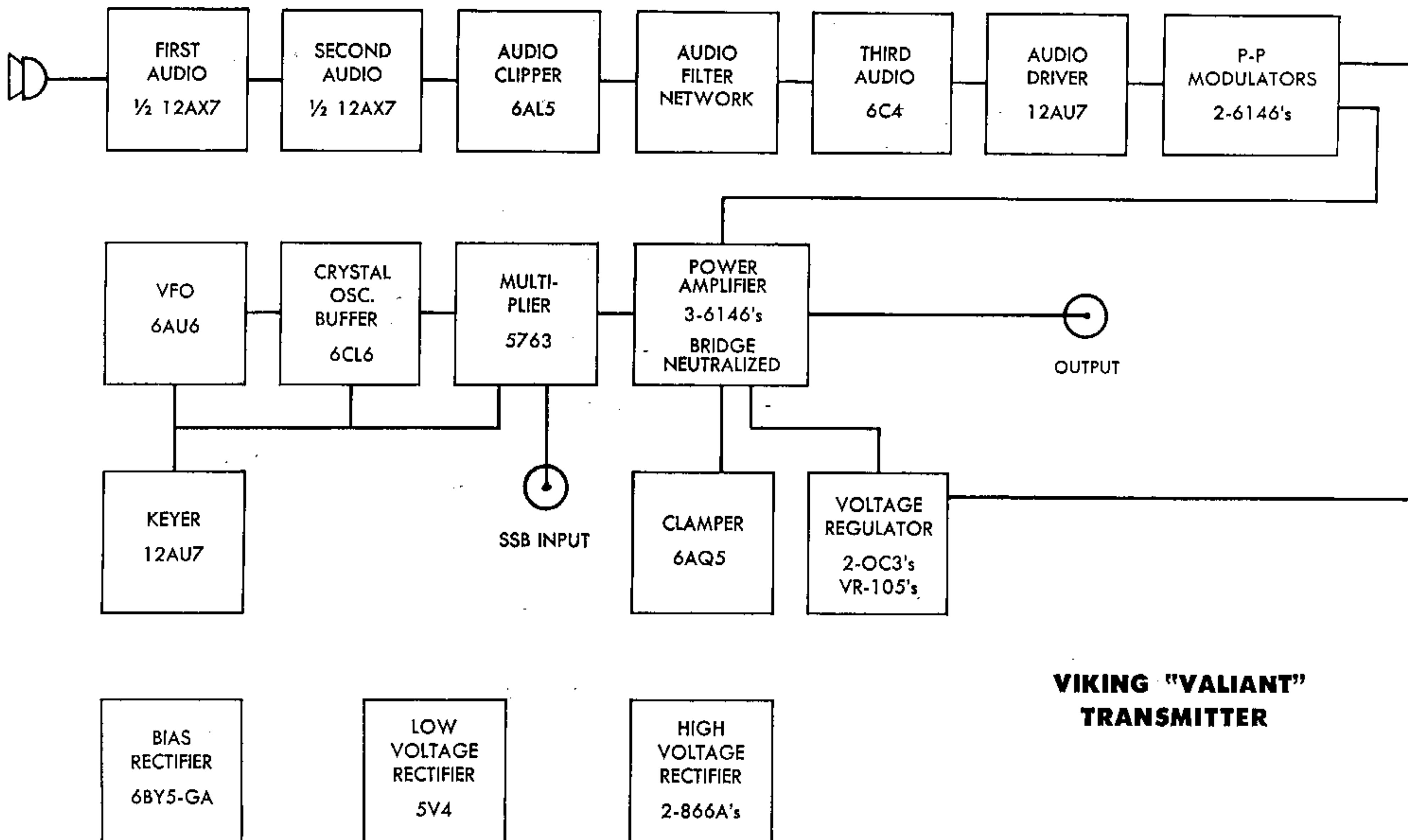

**VIKING "VALIANT"  
TRANSMITTER**

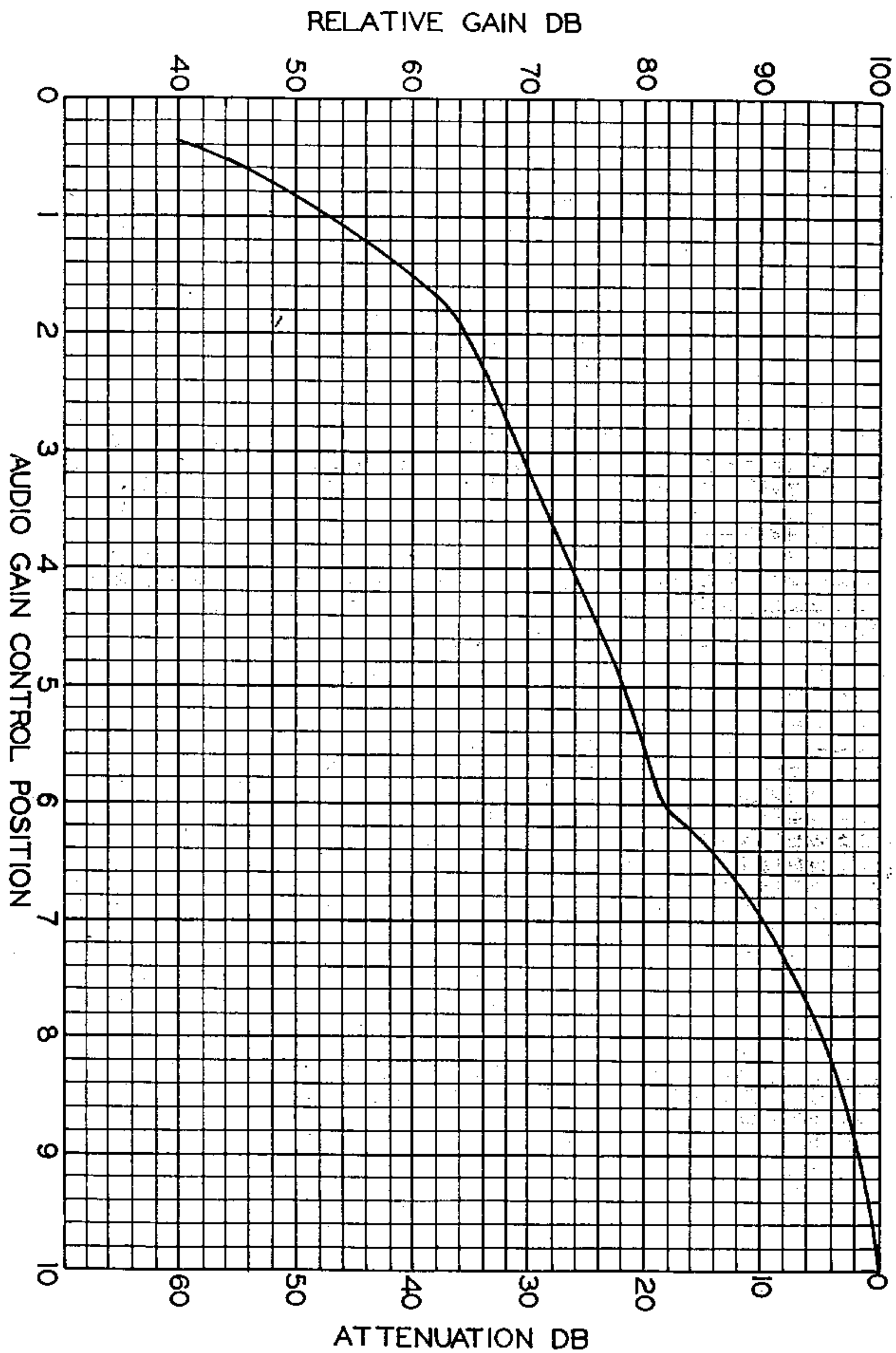

Figure 11, Audio Gain Control Curve

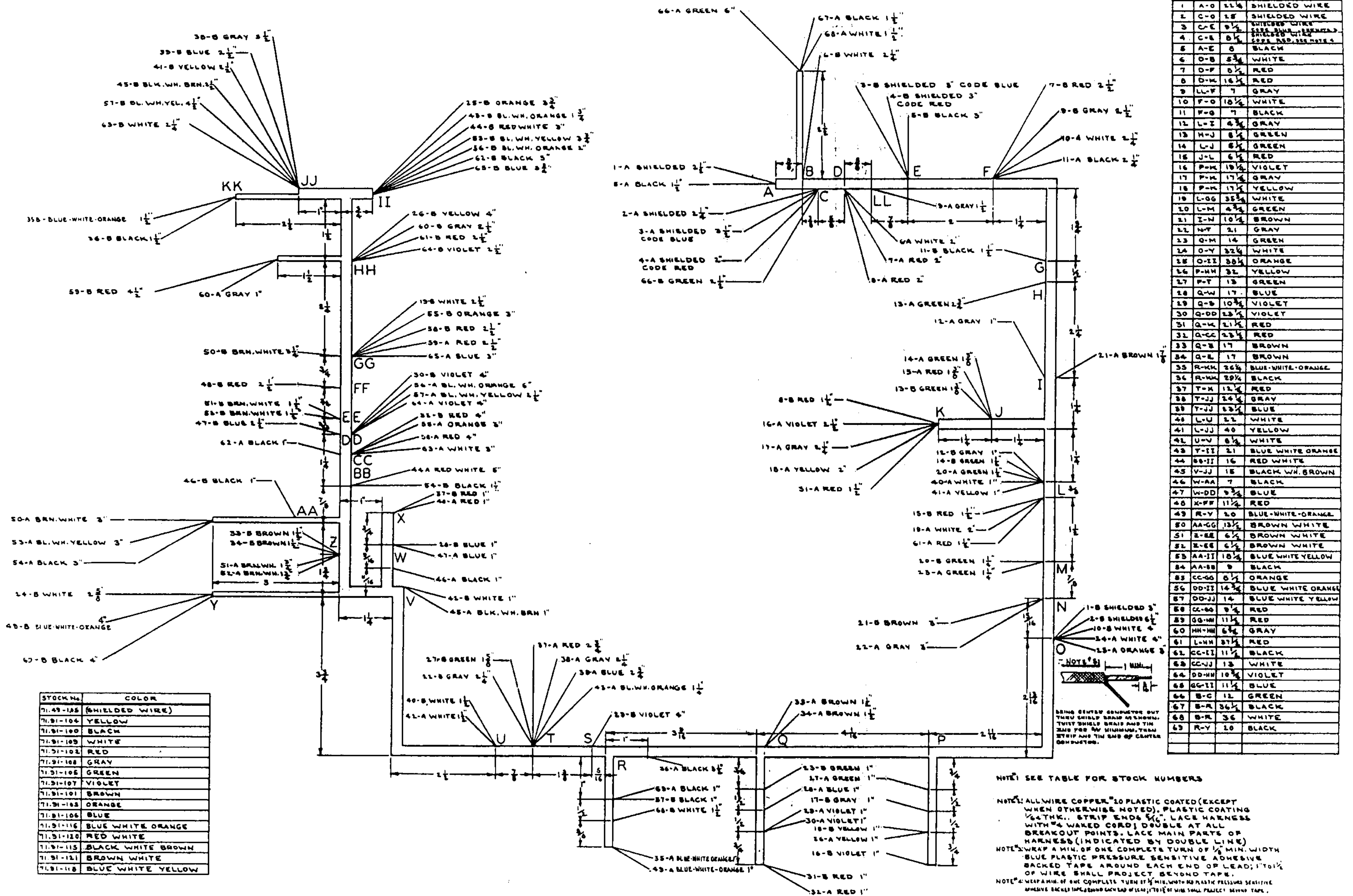

Figure 10, Valiant Wiring Harness

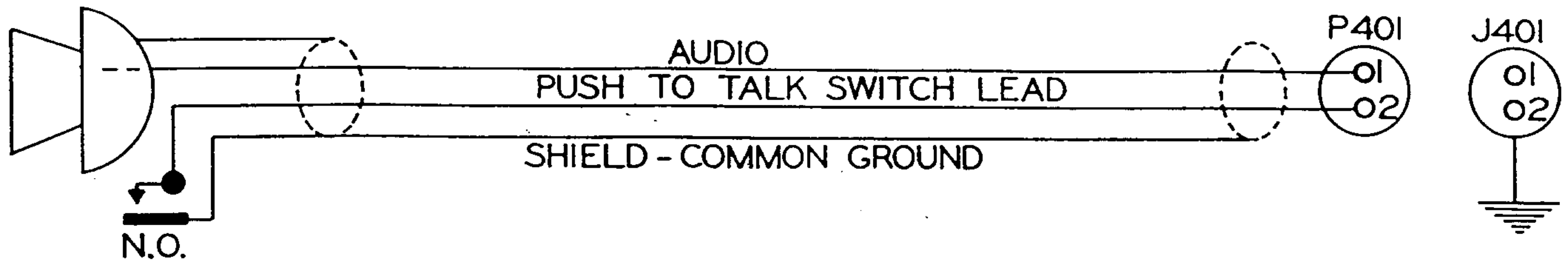
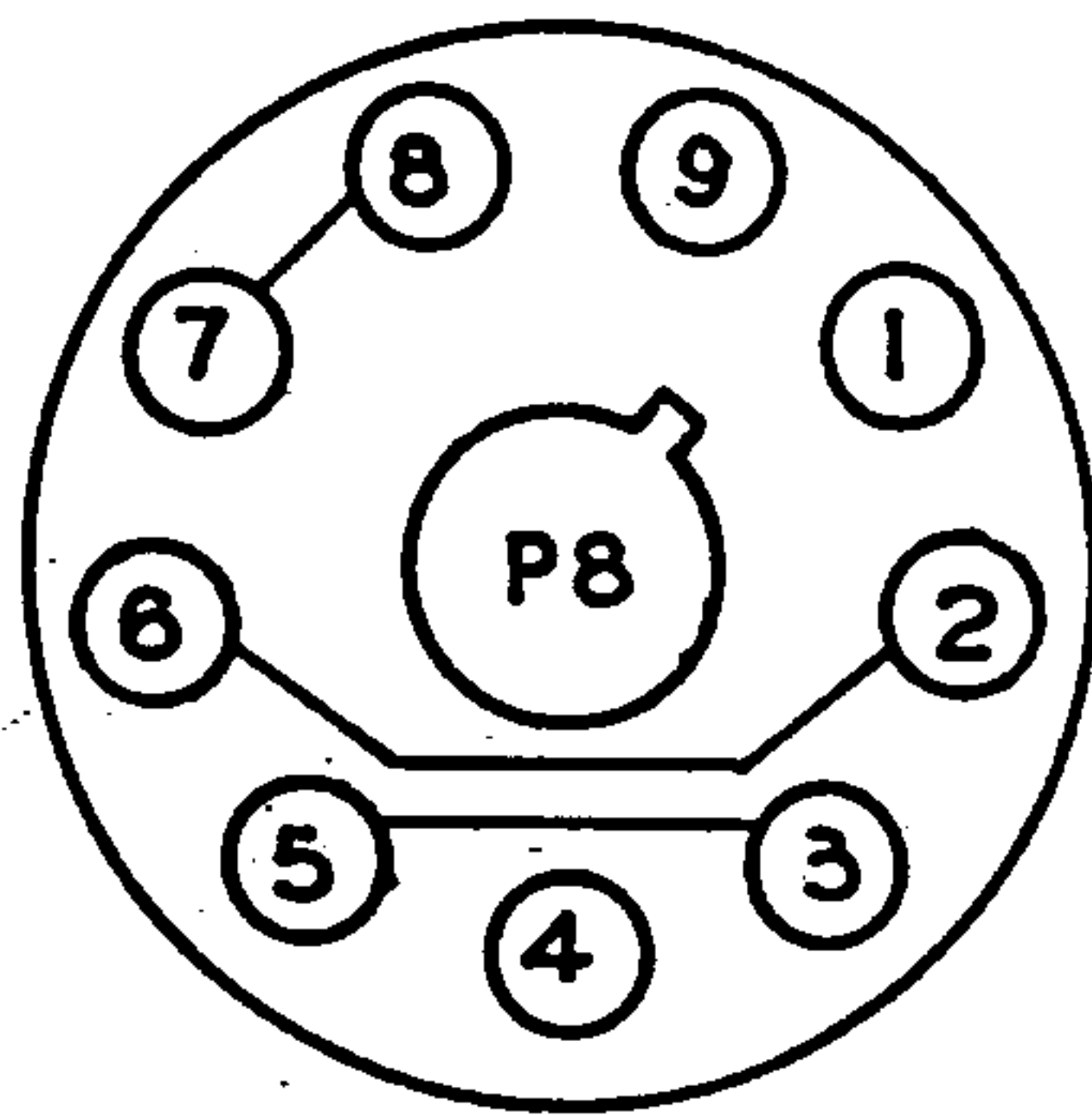
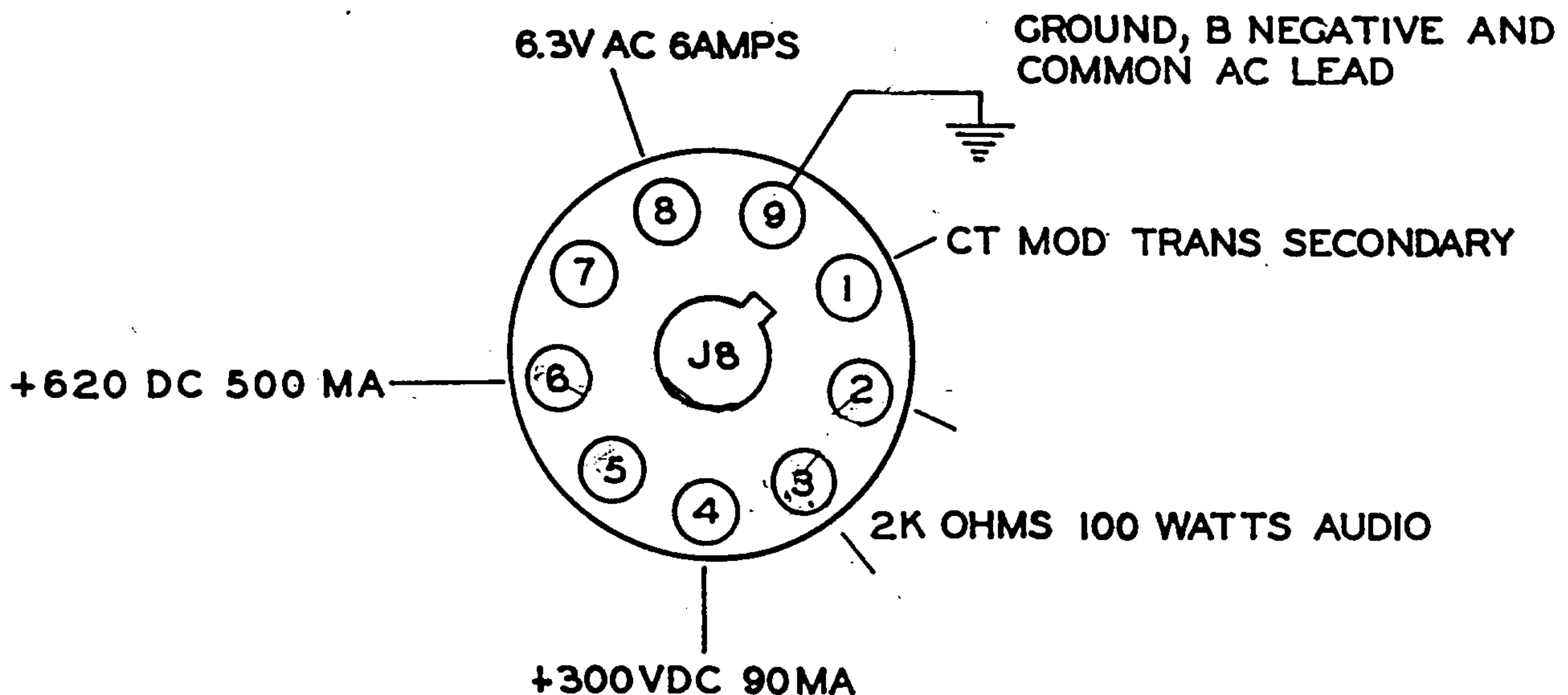

Figure 12a



WIRING PLUG P8. MUST BE  
INSERTED IN J8 FOR OPERATION  
OF VALIANT TRANSMITTER

Figure 12b



THE VALIANT MAY BE USED TO SUPPLY POWER  
FOR OR TO MODULATE ANOTHER TRANSMITTER.  
J8 MATES WITH AN AMPHENOL 86-PM9 PLUG.  
TO USE MODULATOR CONNECT PINS 7 AND 8 TOGETHER.

Figure 12c

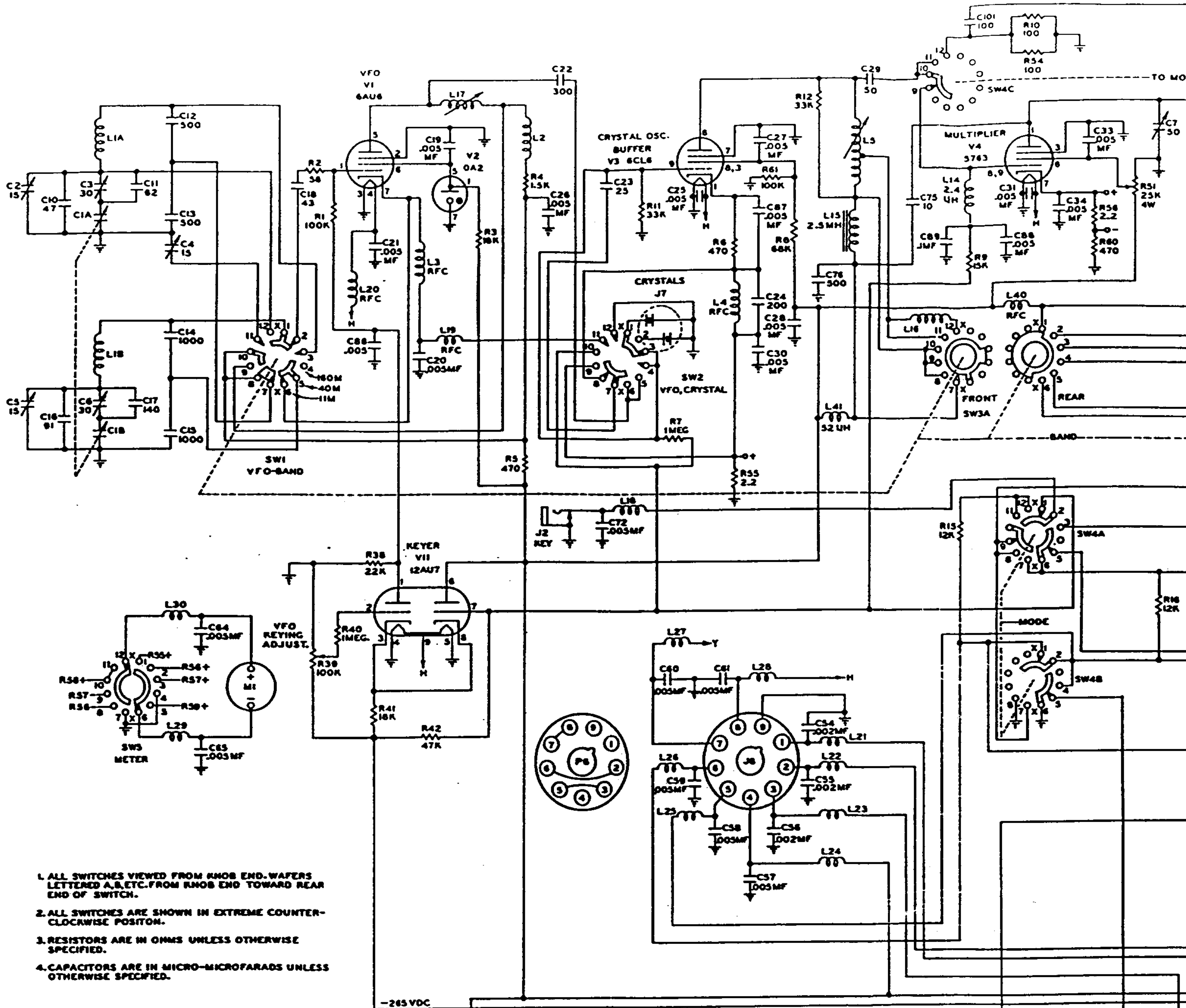

1. ALL SWITCHES VIEWED FROM KNOB END. WAFERS LETTERED A, ETC. FROM KNOB END TOWARD REAR END OF SWITCH.
2. ALL SWITCHES ARE SHOWN IN EXTREME COUNTER-CLOCKWISE POSITION.
3. RESISTORS ARE IN OHMS UNLESS OTHERWISE SPECIFIED.
4. CAPACITORS ARE IN MICRO-MICROFARADS UNLESS OTHERWISE SPECIFIED.

-265 VDC

REV. 11-1-56

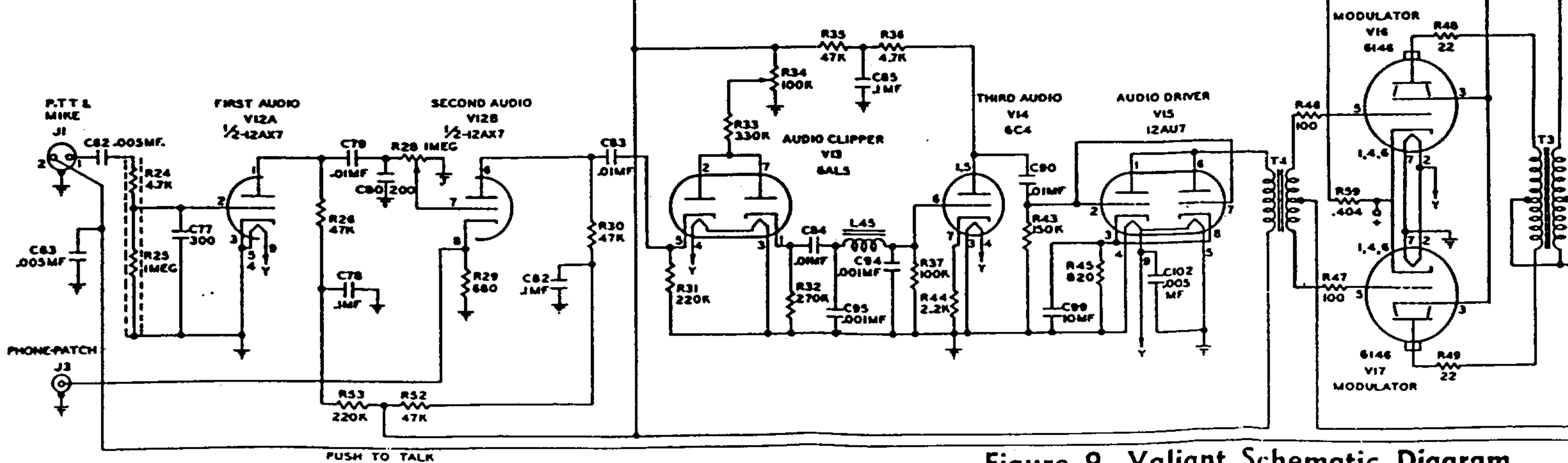
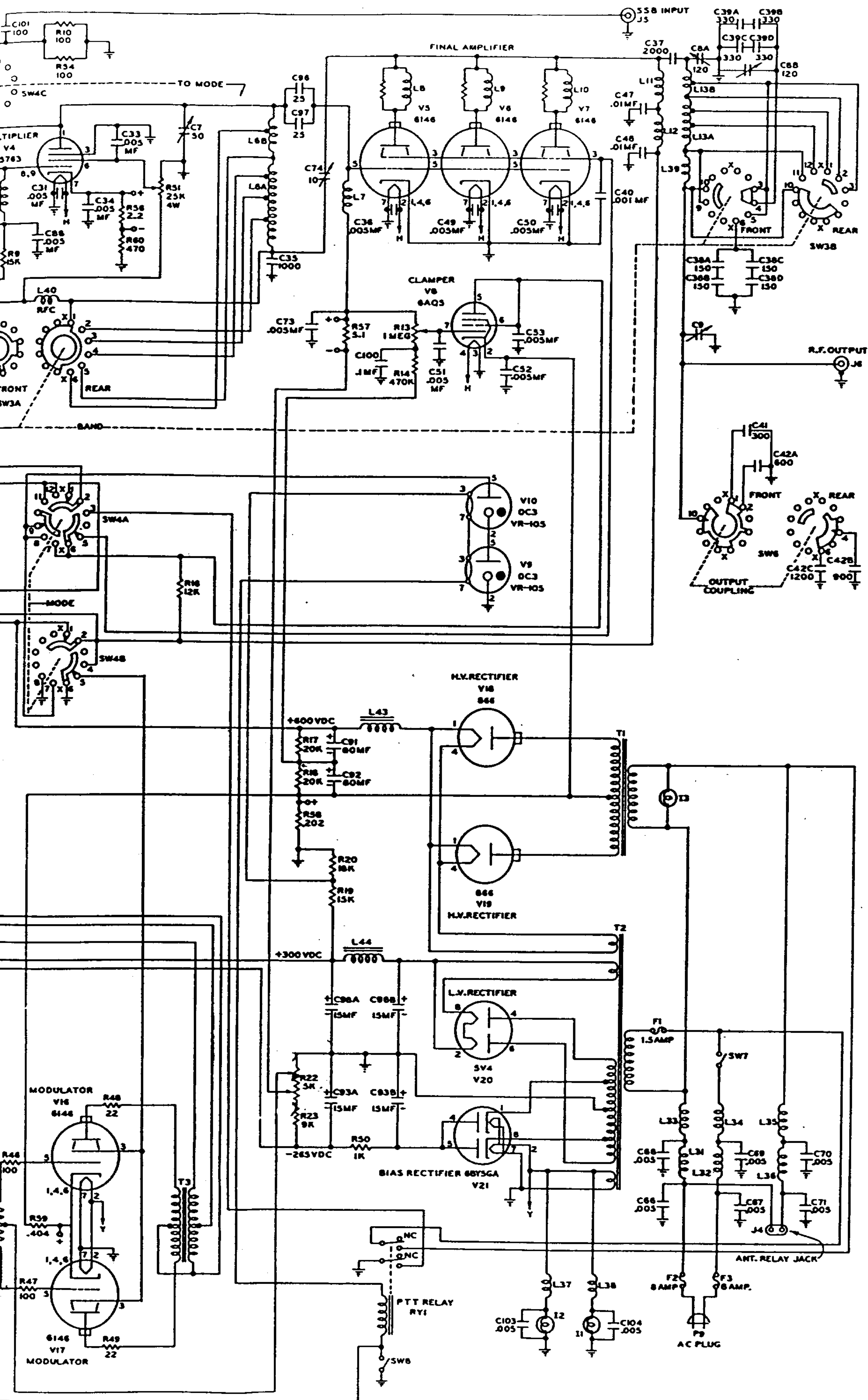

Figure 9, Valiant Schematic Diagram



Schematic Diagram

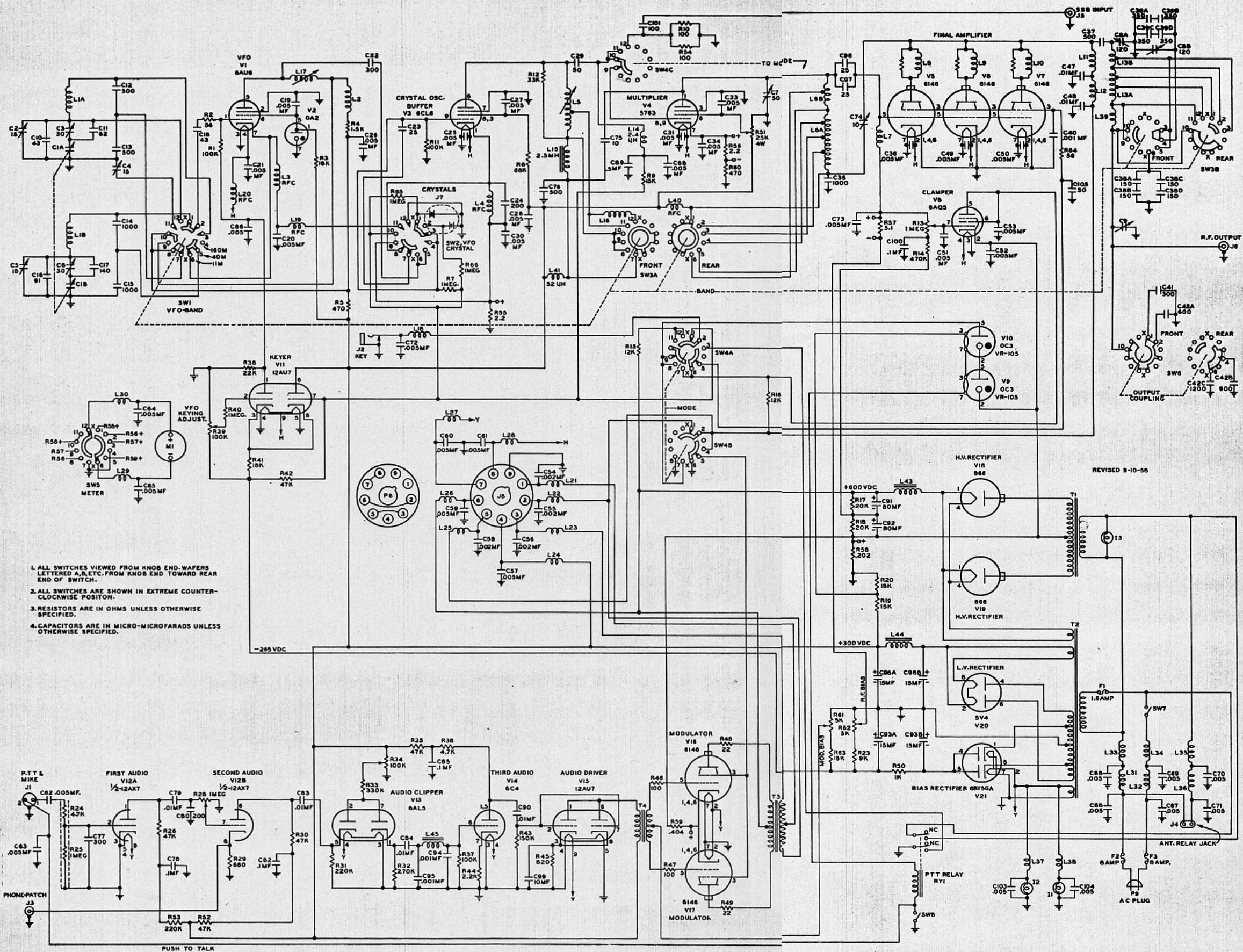

Figure 9, Valiant Schematic Diagram