

SOLID STATE

DIGITAL PHASE LOCKED SYNTHESIZER

VHF FM TRANSCEIVER



MODEL FM144-10SXR II

OPERATOR'S INSTRUCTIONS

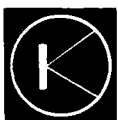

KYOKUTO DENSHI CO., LTD.

21-25, 6-CHOME, HONCHO, NAKANO-KU, TOKYO PHONE: TOKYO (382) 2681

1. GENERAL FEATURES

THIS IS A VHF FM TRANSCEIVER FOR MOBILE AND BASE STATION USE WHICH HAS BEEN DESIGNED TO BE "EASY-TO-USE" AND YET MINIATURIZED TO THE MAXIMUM EXTENT POSSIBLE WITHIN THE LIMITS OF PRACTICABILITY CONSISTENT WITH THE MAINTENANCE OF HIGH STANDARDS OF QUALITY, PERFORMANCE AND RELIABILITY.

(A) FREQUENCY COVERAGE AND CHANNELIZATION

Transmit: a) 144.000 - 145.995MHz, 5KHz steps (400 channels), or
b) 146.000 - 147.995MHz, 5KHz steps (400 channels)
Receive: 144.000 - 148.995MHz, 5KHz steps (1,000 channels)

(B) REPEATER OPERATIONS

Simplex and duplex modes of operations are selected by the RPTU-SIMP-RPTD (repeater UP - simplex - repeater DOWN) toggle on the front panel. The UP and DOWN positions automatically shifts the transmitting frequency 600KHz higher or lower than the receiving frequency which remains displayed on the LED's.

(C) DIRECT LED READOUT OF OPERATING FREQUENCY

Six full digits of LED frequency display are provided continuously. This permits closer spacing between digits compared to mechanical methods of display and facilitates accurate reading of frequency at a glance.

(D) FREQUENCY SELECTION

The selector switches for the 100KHz and 10KHz steps require frequent operation. A large and small knob have been arranged coaxially like the knobs of an airliner cockpit control panel. The knobs stop at both ends of travel at positions 0 and 9 making it possible to change frequency by feel only without having to refer to the LED's visually. This permits keeping one's eyes on road conditions at all times while driving.

(E) RECEIVER FRONT END AUTO-TUNING

Varicap diodes are used for tuning circuits of the RF stages. These diodes are controlled by voltages obtained from the PLL providing automatic tuning of these circuits through the wide band of 144.000 - 148.995MHz and thus maintaining full sensitivity at all times.

(F) FILTER CIRCUITS

A combination of a monolithic crystal filter and LC circuits in the 1st IF amplifier provides a superior skirt selectivity characteristic. A 9-pole ceramic filter is used in the 2nd IF to obtain a sharp bandpass characteristic. Provision has been made in the printed circuit board for the installation of a 15-pole filter unit if a still sharper adjacent channel rejection characteristic is desired. (See page 10)

CAUTION

READ THIS MANUAL COMPLETELY BEFORE ATTEMPTING TO OPERATE TRANSCEIVER

DO NOT OPERATE THE POWER ON/OFF (PULL ON POWER) SWITCH WHILE KEYING THE TRANSMITTER. SWITCHING TRANSIENTS MAY POSSIBLY DAMAGE THE TRANSCEIVER.

DO NOT CHANGE FREQUENCY WHILE KEYING TRANSMITTER. TRANSMITTER MAY SEND OUT SIGNAL ON RANDOM OFF-BAND FREQUENCY PRIOR ACQUIRING PLL LOCK UP.

HEAT GENERATION IS QUITE HIGH DUE LARGE NUMBER OF DIGITAL IC'S USED. OPERATE WITH TRANSCEIVER IN AS WELL VENTILATED LOCATION AS POSSIBLE.

DO NOT TRANSMIT WITH ANTENNA TERMINAL OPEN OR SHORTED. MODERN TRANSISTORS ARE QUITE RUGGED. HOWEVER, PERMANENT DAMAGE MAY BE CAUSED.

USE A POWER SUPPLY OF AT LEAST 5 AMPERE CAPACITY WITH GOOD REGULATION FOR FIXED STATION OPERATIONS.

OPERATION IN DUPLEX MODE RESULTS IN TRANSMITTER OPERATING 600KHZ HIGHER OR LOWER THAN INDICATED FREQUENCY. THIS MUST BE KEPT IN MIND WHEN OPERATING AT BAND EDGES TO PREVENT POSSIBLE OUT-OF-BAND TRANSMISSIONS.

CONTENTS

| | | |
|-----|---|---------|
| 1. | GENERAL FEATURES | 1 |
| 2. | DESCRIPTION OF OPERATING CONTROLS AND FUNCTIONS.... | 3 |
| 3. | INSTALLATION AND OPERATION | 6 |
| 4. | CIRCUIT DESCRIPTION | 7 |
| 5. | ADJUSTMENTS AND OTHER APPLICATIONS | 10 |
| 6. | INTERNAL VIEW | 12 |
| 7. | COMPONENT LOCATION CHART | 13 |
| 8. | BLOCK DIAGRAM | 15 |
| 9. | SPECIFICATIONS | 16 |
| 10. | CIRCUIT DIAGRAM | FOLD IN |

(G) DIRECT FREQUENCY MODULATION OF VCO

A varicap diode is used to apply modulation directly to the voltage controlled oscillator resulting in less distortion than the more conventional reactance phase shift modulators.

(H) HIGH/LOW POWER OUTPUT

High transmitter output of 10 watts and low output of 1 watt can be selected by the switch mounted on the microphone. Thus when communicating with near-by stations the low transmitter power output position may be used to minimize interference to other stations and conserve battery power. Although adjusted at the factory to a normal 1 watt, power output in the low power position can be set by a screwdriver adjustment from a level of 0 to a maximum of 10 watts. This is convenient to use to set low power to approximately 100 milliwatts to use when travelling in company of another car or rag-chewing with an extremely near-by station. (See page 11)

PR16

(I) PRIORITY CHANNEL

The first position of the MHz selection switch is labelled "P" and is set up as a priority channel. This is usually set up for the main calling frequency of the country of intended use. This frequency may be reprogrammed by rewiring the diode matrix located in the PLL module. Any frequency with 10KHz spacing may be selected. (See page 11)

(J) MODULAR CONSTRUCTION

The transceiver is sub-divided into 6 individual printed circuit board assemblies. These are: the receiver, the transmitter exciter, the transmitter booster amplifier, the voltage controlled oscillator, the phase lock loop and the power supply. This modularized construction reduces stray coupling between circuits and thus spurious responses and emissions and serves to improve performance, reliability and ease of servicing.

(K) CONNECTION OF SELECTIVE CALLING UNIT, ETC.

A fully wired outlet is provided on the back panel for connection of a KYOKUTO SC-10 tone encoder/decoder unit. This outlet can also be used for connection of your favorite tone burst, touch-tone or phone patch unit. (See page 5)

2. DESCRIPTION OF OPERATING CONTROLS AND FUNCTIONS

The following paragraphs are numbered to correspond with numbers on illustrations of front and rear panel. (Rear panel view on page 5.)

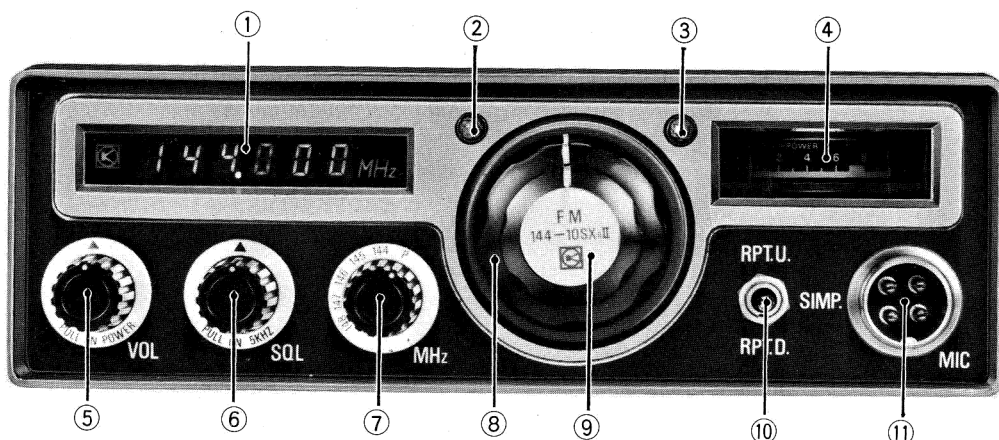

FRONT PANEL VIEW

- (1) FREQUENCY DISPLAY: - Direct digital readout of frequency selected is provided by six bright digits of LED's. During duplex operations, only the receiving frequency is displayed.
- (2) CHANNEL BUSY INDICATOR: - During reception of an incoming signal this indicator will light up showing the channel is in use. The light (LED) is activated whenever the squelch is opened and operates regardless of the setting of the volume control. It also functions during a "tone squelch" lock condition when the transceiver is used in conjunction with a KYOKUTO SC-10 selective calling unit.
- (3) PLL UNLOCK INDICATOR: - During unlock conditions of the PLL the voltage controlled oscillator may be operating at any random frequency. To prevent keying of the transmitter during unlock conditions, this indicator is provided to light up and warn the operator.
- (4) DUAL PURPOSE "S" METER: - This meter provides indications of both receiving and transmitting conditions. During reception, the meter functions as an "S" meter and is set at the factory to indicate approximately 8 with a 20dB (odB = 1uV) incoming signal. During transmission the meter gives an approximate indication of output power and an output of 10 watts into a 50 ohm load will result in a reading of about 7 or 8. A reading considerably higher or lower than this amount could be an indication of failure of either the antenna or feeder.

- (5) VOLUME CONTROL, PULL ON POWER: - Pulling on this knob will apply main power to the transceiver. Turning the knob to the right increases volume and turning it in the opposite direction reduces volume. Pushing the knob in will turn off main power.
- (6) SQUELCH CONTROL, PULL ON 5KHZ: - Pulling this knob raises the frequency of operation by 5KHz, pushing the knob back in lowers operating frequency by 5KHz. Setting of the knob can be monitored by reference to the last digit of the LED frequency display. Turning the knob in a clockwise direction will operate the squelch and eliminate receiver noises from being heard from the speaker except when an incoming signal is received.
- (7) MHZ CONTROL, PRIORITY CHANNEL: - This knob controls the MHz order of operating frequency. The "P" position indicates the priority channel and permits instantaneous selection of a preselected frequency regardless of the position of the other frequency selector knobs. The priority channel of this transceiver is set up on _____ MHz. (See page 11 for instructions on how to reprogram if another frequency is desired.)
- (8) 100KHZ SELECTOR KNOB: - This knob controls a ten position switch to select operating frequency in 100KHz steps from 00 to 900KHz.
- (9) 10KHZ SELECTOR KNOB: - This knob controls a ten position switch to select operating frequency in 10KHz steps from 00 to 90KHz. Both this knob and the 100KHz selector knob rotate through 10 positions and are mechanically stopped at positions 0 and 9 to facilitate frequency changing by feel only.
- (10) MODE SELECTOR SWITCH: - This is the simplex/duplex mode selector switch. In the SIMPLEX position the transmitter frequency is the same as the receiver frequency. In the "RPTU" position the transmitter frequency is off-set by +600KHz from the receiver frequency and in the "RPTD" position off-set by -600KHz. (Please note that during duplex operations the LED display shows only the receiver frequency continuously thus caution should be exercised at extreme band edges to avoid making an out-of-band transmission.)
- (11) MICROPHONE CONNECTOR: - The microphone provided with the transceiver should be plugged into this connector. Operation of the P/T (press-to-talk) switch on the microphone will key the transmitter. High and low transmitter power is selected by the switch mounted on the microphone. (Microphone provided has an impedance of 600 ohms.)

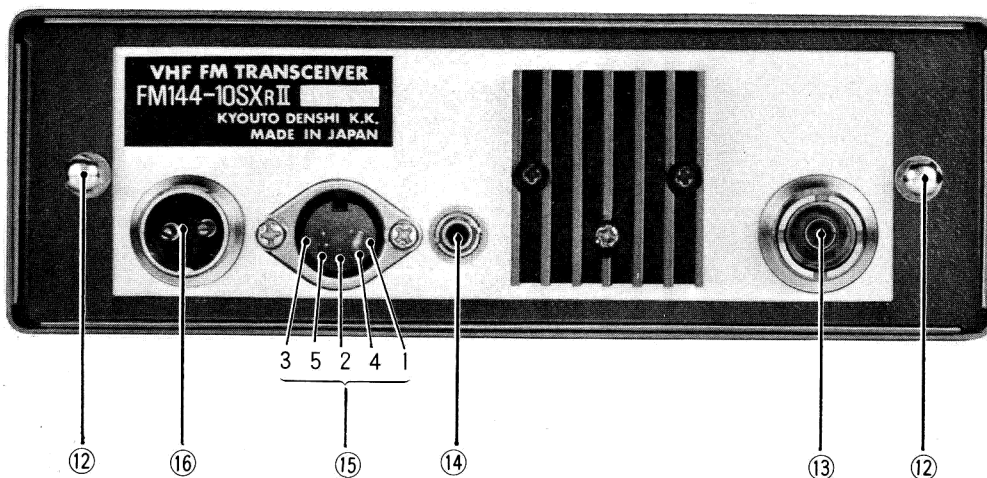

REAR PANEL VIEW

- (12) COVER CAP NUTS: - The outer case can be removed by first unscrewing these two cap-nuts and drawing off the case to the rear.
- (13) ANTENNA CONNECTOR: - This is an SO-239 type connector for the antenna feeder. The transmitter is designed to operate into a load of between 50 to 75 ohms, however, mobile antennas tend to be of low impedance and the use of 52 ohm coax is recommended. (The transmitter is adjusted at the factory with a 52 ohm dummy load.) This connector is threaded to accept PL-239 type plugs with both inch and metric threads.
- (14) EXTERNAL SPEAKER CONNECTOR: - This is a miniature phone jack type connector for an external speaker. The internal speaker is of necessity quite small and both volume and tone qualities are improved by connection of a larger sized external speaker. The internal speaker is automatically disconnected whenever a plug is inserted in this jack.
- (15) SEL-CALL CONNECTOR: - This is a 5 conductor "DIN" standard receptacle for the connection of a KYOKUTO SC-10 tone encoder/decoder unit. When not in use pins 1 and 4 must be shorted using a "U" link as shown in the photograph above. (Jumper is installed ex-factory.) The following connections are available at this receptacle which can be used for connection of a tone-burst, touch-tone or phone-patch unit. (Pin numbers in accordance with "DIN" standard numbering.) #1 - Receiver audio output. #2 - Transmitter modulator input, i.e., microphone. #3 - Transmitter P/T. Apply ground to key transmitter. #4 - Transceiver internal speaker. #5 - +12V DC.
- (16) POWER CONNECTOR: - This is a two conductor receptacle for connection of DC power to the transceiver. A power cable including a fuse holder and fuse is included as a standard accessory with the transceiver.

3. INSTALLATION AND OPERATION

(A) MOBILE INSTALLATIONS

- a) Mount the metal bracket provided as a standard accessory with the transceiver under the dashboard of the automobile. Secure the transceiver to the bracket using the wing screws provided. The angle of installation is adjustable and should be set for ease of operation.
- b) Connect the antenna to the SO-239 type connector on the rear panel. (Item #13, illustration on page 5.)
- c) Use the power cord supplied with the transceiver to connect to battery terminals. (Red - positive, black - negative.) If a longer cable is required to reach battery terminals directly a heavier gauge cable should be used to minimize voltage losses. Power source should be 13.5 volts, +10%. Connection to power source at dashboard of car should be avoided if at all possible to prevent pick-up of alternator whine into receiver and transmitter.
- d) Connect microphone provided with transceiver to microphone connector. (Item #11, illustration on page 3.)
- e) Confirm fuse is installed in fuse holder in power cable and that a "U" link jumper is installed in "DIN" receptacle. (Item #15, illustration on page 3.)

(B) FIXED STATION INSTALLATION

- a) A 13.5 volt 5 ampere DC power source is required. Voltage fluctuation during transmission is an indication of insufficient capacity of the supply. A good reliable and stable supply of sufficient amperage should be used in order to obtain optimum results.
- b) A miniature phone plug type connector is provided as a standard accessory with the transceiver for connection of an external speaker. A 4-ohm speaker should be used for best results.

(C) OPERATING INSTRUCTIONS

- a) Pull out "PULL ON POWER" knob. (Item #5, page 3.) The panel meter and frequency display LED's will light up immediately.
- b) The MHz, 100KHz, 10KHz and "PULL ON 5KHz" knobs should be set to the desired frequency of operation.
- c) Turn "SQUELCH" control to full counter clockwise direction.
- d) The volume control should be turned gradually in a clockwise direction from the full counter-clockwise position until a steady rushing noise is heard from the speaker.
- e) Gradually turn "SQUELCH" control in a clockwise direction until the steady rushing noise is no longer heard. Leave control set at this position.
- f) Press the P/T (press-to-talk) switch on the microphone to key transmitter. Select "HI" or "LO" transmitter power using switch mounted on the microphone.

4. CIRCUIT DESCRIPTION

(A) RECEIVER

The incoming signal is fed to the RF amplifier, Q-1, a dual gate MOSFET through the input transformer, L-1 and thence to the LC tuning circuits L-2 through L-4. These tuned circuits are tuned by varicap diodes D-1 through D-4 and keeps receiver sensitivity constant over the entire frequency range covered. The signal is next fed to the 1st mixer, also a dual-gate MOSFET and is converted to the 1st IF of 16.9MHz. Injection to the 1st mixer is provided by the VCO which is described in a later paragraph.

The converted IF signal is passed through a monolithic crystal filter and then to the IF amplifier Q-3, a junction type FET device. The signal next passes through a double tuned LC circuit which cleans up the skirt selectivity of the crystal filter and thence on to the 2nd mixer, Q-4 which is another JFET. The 2nd local oscillator Q-10 is also a JFET for better oscillator stability and clean output waveform and which is crystal controlled at a frequency of 16.445MHz. This output is fed to the gate of Q-4.

The converted signal of 455KHz passes first through a ceramic filter which determines the bandwidth of the receiver and then to the amplifier and limiter circuitry made up of discrete components Q-5 through Q-9. By careful design a stable and low phase shift amplifier has been achieved. After limiting, the signal is detected by the discriminator circuit of D-7 and D-8. A portion of the detected signal is passed through the volume control and amplified by Q-16 and IC-1 and then fed to the speaker. Another portion of the detected signal is passed through the squelch control and then through the noise amplifiers Q-11 Q-12 and is then rectified in a voltage doubler circuit D-10 and D-11. The rectified signal after filtering controls the base voltage of the audio amplifier Q-16 through the switching circuit consisting of Q-13. The busy lamp circuit senses the collector voltage changes of switch Q-13 and after DC amplification by transistors Q-14 and Q-15 controls the LED mounted on the front panel.

The 455KHz signal present at the collector of IF amplifier transistor Q-6 is rectified by diodes D-5 and D-6 in a voltage doubler circuit and is fed to the front panel meter to activate the "S" meter. Trim-pot R-23 adjusts gain of the 2nd IF amplifier and is used to set the reading of the "S" meter.

Transistor Q-17 is a voltage regulator for the receiver 9-volt supply bus and is controlled by zener diode, D-11.

(B) TRANSMITTER

Diodes D-1 through D-3 select the proper crystal for heterodyne oscillator Q-1 as controlled by the mode toggle S-1. (RPTU - 17.5MHZ,

SIMP - 16.9MHz and RPTD - 16.3MHz.) The signal is fed through buffer stage Q-2 and then to the balanced mixer, diodes D-4 through D-7, where it is mixed with the receiver local injection signal from the VCO. The converted signal (which is now at the final transmitting frequency) is amplified through 6 stages of straight amplification each of which have double tuned LC circuits to achieve approximately 1 watt output at the output terminals.

Audio from the microphone is amplified by IC-1 and then after limiting, is fed through a 3KHz 12dB/octave LC filter to prevent splatter. The audio is fed to varicap diode D-2 in the VCO unit through an emitter-follower stage, Q-7, in a direct frequency modulator circuit of the VCO itself.

The output from the collector of the final amplifier stage, Q-6, is passed through a double pi-section low pass filter to keep harmonic output and spurious emissions at a minimum.

(C) TRANSMITTER POWER BOOSTER

The 1 watt signal from the transmitter is amplified by Q-1 and Q-2 to achieve a power output of over 10 watts. This unit is completely shielded and contains a three section pi-type low pass filter, with each of the sections shielded from each other by partitions. The thick aluminum base plate doubles as a heat sink and part of the shield around the amplifier unit.

A portion of the output is rectified by diode D-1 and is fed to the front panel meter. Coupling of the diode to the output lead is such that the front panel meter provides an approximate indication of forward power. Meter reading is adjustable by moving the location of the diode with respect to the hot lead through the hole provided in the shielded cover plate.

(D) VOLTAGE CONTROLLED OSCILLATOR (VCO) UNIT

IC-1 and varicap diode D-1 are connected in a oscillator circuit covering 127.1 through 132.09MHz. Output from this circuit is fed through buffer stages Q-1 and Q-2 and then connected to the receiver unit 1st mixer and also to the balanced mixer of the transmitter unit. Output is also fed through the isolation amplifier Q-3 and then heterodyned down to a range of 4.00 - 8.99MHz by mixing in Q-4 with the output of the heterodyne oscillator Q-7. The frequency of oscillation of Q-7 is controlled by either of crystals X-1 (41.03166MHz) or X-2 (41.03MHz) as selected by the "PULL ON 5 KHZ" control. Q-7 is an overtone mode oscillator and the output from buffer stage Q-8 is either 123.09 or 123.0949MHz. The output of mixer, Q-4 is amplified by Q-5 and Q-6, and then sent on to the PLL programmable counter having undergone wave shaping in stage Q-6.

Varicap diode D-2 is included in the VCO circuit module and achieves direct frequency modulation of the VCO by receiving audio from the microphone amplifier and limiter stage in the transmitter unit.

(E) PHASE LOCK LOOP (PLL) UNIT

The 4.00 to 8.99MHz signal from the VCO is entered into the programmable counter made up of IC-5 through IC-7 and is counted. IC-5 counts the 1MHz order, IC-6 the 100KHz order and IC-7 the 10KHz order. The output of the counter is applied to the phase comparator, IC-4 after passing through buffer stage, IC-8.

One half of IC-1 generates the 1MHz frequency standard signal. The decade counters IC-2 and IC-3 divide this signal to 100KHz and 10KHz respectively. The sub-divided signal is then fed to the phase comparator IC-4. IC-4 contains a second phase comparator which is utilized in conjunction with the remaining half of IC-1 used as a N-AND gate to generate an output voltage when in an unlock condition. This output is amplified by DC amplifiers Q-2 and Q-3 and then actuates D-2, an LED mounted on the front panel to give an indication of unlock conditions. A portion of this voltage is also used to control the varicap diodes in the receiver RF circuits.

(F) DECODER/DISPLAY UNIT

This unit obtains the BCD coded output programmed by control switches S-1, S-2 and S-3 which is applied to IC-1, IC-2 and IC-3 to drive the 7-segment LED display units, D-3 D-4 and D-5.

D-3 displays the 1MHz digit, D-4 the 100KHz digit and D-5 the 10KHz digit. The 10MHz and 100MHz digit LED's D-2 and D-1 remain constant. The 1KHz digit D-6 indication is controlled by the "PULL ON 5KHz" switch on the front panel to indicate either 0 or 5.

(G) POWER SUPPLY UNIT

The DC input from the power connector (13.5v DC) is passed through the noise filter coil L-1, and then fed to regulator Q-5, D-2, to supply the 9-volt supply bus. Power to the power booster unit is controlled by regulator components Q-1 through Q-4 and D-1 so that power supplied to the booster will not exceed 14 volts and constitutes an over-voltage protection circuit. This circuit is also used to lower the booster output to a previously established level by setting of the control VR R-3 for the HI/LO output selection. Power to supply the 5-volt digital TTL circuits is regulated by IC-1 mounted on the rear panel of the main chassis. Reverse polarity protection for the entire transceiver is provided by diode D-3 mounted directly on the input power connector.

5. ADJUSTMENTS AND OTHER APPLICATIONS

(A) RECEIVER METER SENSITIVITY

The "S" meter sensitivity is adjusted at the factory to indicate 8 with an input signal of +20dB (0dB=1uV). This can be changed by adjusting trim-pot VR R-23.

(B) TRANSMITTER MODULATION (DEVIATION)

Transmitter modulation is adjusted at the factory to ± 5 KHz. This can be adjusted from 0 to a maximum of ± 15 KHz by varying VR's R-20 and R-24 on the transmitter printed circuit board.

(C) DISCRIMINATOR METER

The difference between the incoming signal frequency and the receiver center frequency can be seen by connection of a ± 100 uA meter to the detector circuit. This can be accomplished by connecting the meter through a 20K Ω resistor to either the hot end of the volume control, VR R-1, or the detector output pin "DET" on the receiver printed circuit board.

(D) CERAMIC FILTERS

The standard filter installed in the transceiver is a 9-pole ceramic filter with a selectivity of ± 6 KHz, -6dB and ± 12 KHz, -40dB. Other bandwidth filters are also available as listed below. The receiver printed circuit board pattern has been designed to also accept a higher quality 15-pole ceramic filter with varying characteristics which are also listed herein.

9-pole filters

- (A) ± 17.5 KHz -6dB, ± 30 KHz -50dB
- (B) ± 15 KHz -6dB, ± 25 KHz -50dB
- (C) ± 13 KHz -6dB, ± 23 KHz -50dB
- (D) ± 10 KHz -6dB, ± 20 KHz -50dB
- (E) ± 8 KHz -6dB, ± 16 KHz -50dB
- (F) ± 6 KHz -6dB, ± 12 KHz -50dB
- (G) ± 4 KHz -6dB, ± 10 KHz -50dB

15-pole filters

- ± 17.5 KHz -6dB, ± 30 KHz -70dB
- ± 15 KHz -6dB, ± 25 KHz -70dB
- ± 13 KHz -6dB, ± 23 KHz -70dB
- ± 10 KHz -6dB, ± 20 KHz -70dB
- ± 8 KHz -6dB, ± 15 KHz -70dB
- ± 6 KHz -6dB, ± 12 KHz -70dB
- ± 4 KHz -6dB, ± 8 KHz -70dB

(E) SELECTIVE CALLING, TONE-BURST, TOUCH-TONE AND PHONE PATCH

The connector provided on the rear panel labelled SELCALL is fully wired for the connection of a KYOKUTO SC-10 tone encoder/decoder unit. The following circuits are wired to this connector.

Pin Number Function

- 1... Receiver audio output
- 2... Transmitter mod. input (Mic.)
- 3... Transmitter keying

Pin Number Function

- 4... Internal speaker
- 5... 12 volts DC, (switched)

When this connector is not in use, pins 1 and 4 must be jumpered with a "U" link to connect receiver audio output to the internal speaker. This connector may be used for the connection of a tone-burst, touch-tone, phone-patch and other similar devices.

(F) ADJUSTMENT OF TRANSMITTER "LO" POWER

Transmitter low power may be set at any level from 0 to 10 watts by adjusting trim-pot VR R-3 located in the power supply unit. This adjustment can be made through the hole on the speaker baffle as illustrated in the COMPONENTS AND ADJUSTMENT LOCATION chart on page 12.

(G) CHANGING PRIORITY FREQUENCY

The priority frequency may be reprogrammed to any desired frequency within the frequency range of the transmitter, and, in increments of 10KHz by rewiring the diode matrix formed by diodes D-2 through D-6 located in the PLL unit. These can be seen by removing the PLL unit cover and are all connected to the feed-thru capacitor to which a white/green wire is connected.

The diodes should be reconnected from this feed-thru capacitor to the 10KHz, 100KHz and 1MHz terminals in accordance with the table below and will provide any frequency in 10KHz increments within the transmitter frequency range. (Attempting to operate the transmitter over a range wider than 2MHz is not recommended, as power output will be reduced and spurious emissions increased due to de-tuning of the transmitter amplifier stages.)

| CODE freq. | A(1) | B(2) | C(4) | D(8) |
|---------------|------|------|------|------|
| 0 | | | | |
| 1 | ○ | | | |
| 2 | | ○ | | |
| 3 | ○ | ○ | | |
| 4 | | | ○ | |
| 5 | ○ | | ○ | |
| 6 | | ○ | ○ | |
| 7 | ○ | ○ | ○ | |
| 8 | | | | ○ |
| 9 | ○ | | | ○ |

BCD CODE

- ×10kHz order
 - A BROWN
 - B RED
 - C ORANGE
 - D YELLOW
- ×100kHz order
 - A GREEN
 - B BLUE
 - C VIOLET
 - D GRAY
- ×1MHz order
 - A WHITE
 - B WHITE-BLACK
 - C WHITE-BROWN
 - D WHITE-RED

WIRE COLOR CODE

6. INTERNAL VIEW

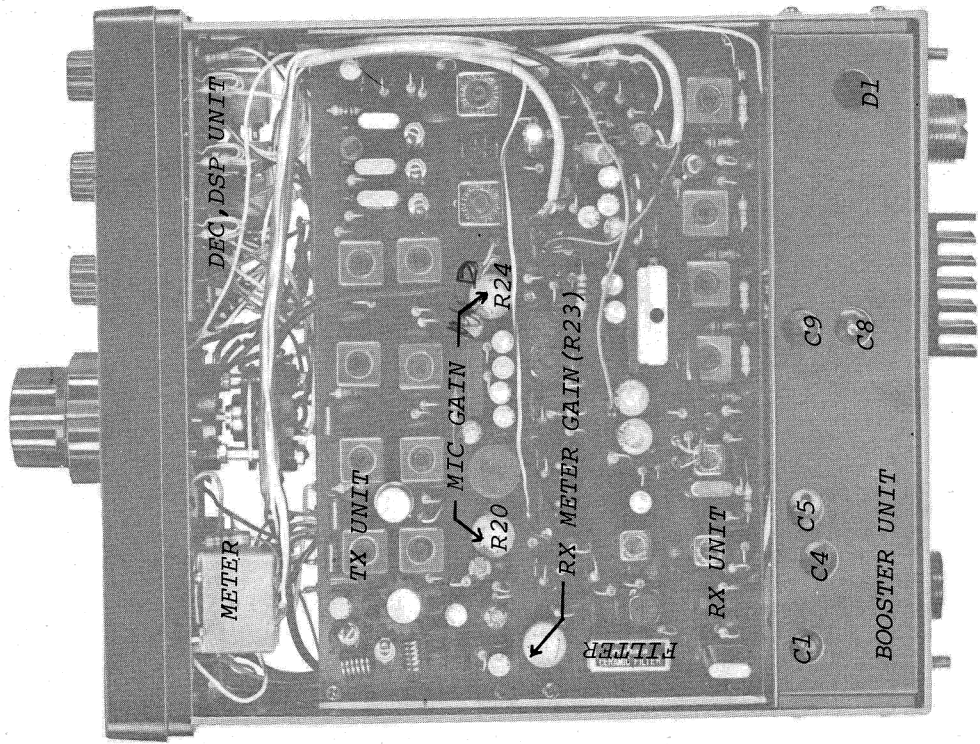

TOP VIEW

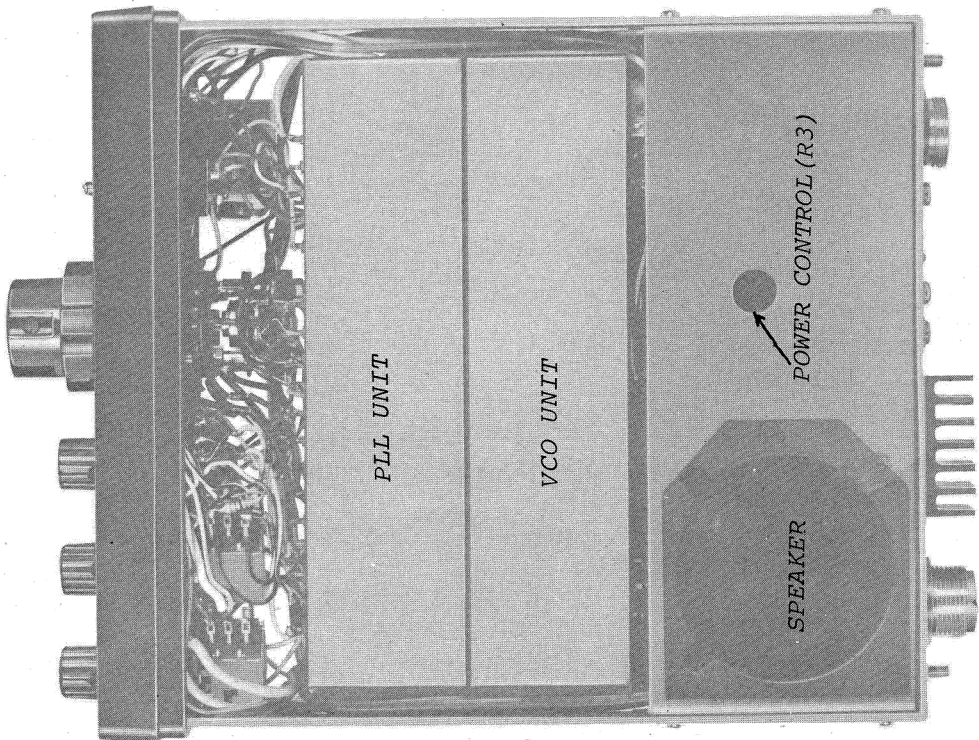

BOTTOM VIEW

7. COMPONENT LOCATION CHART

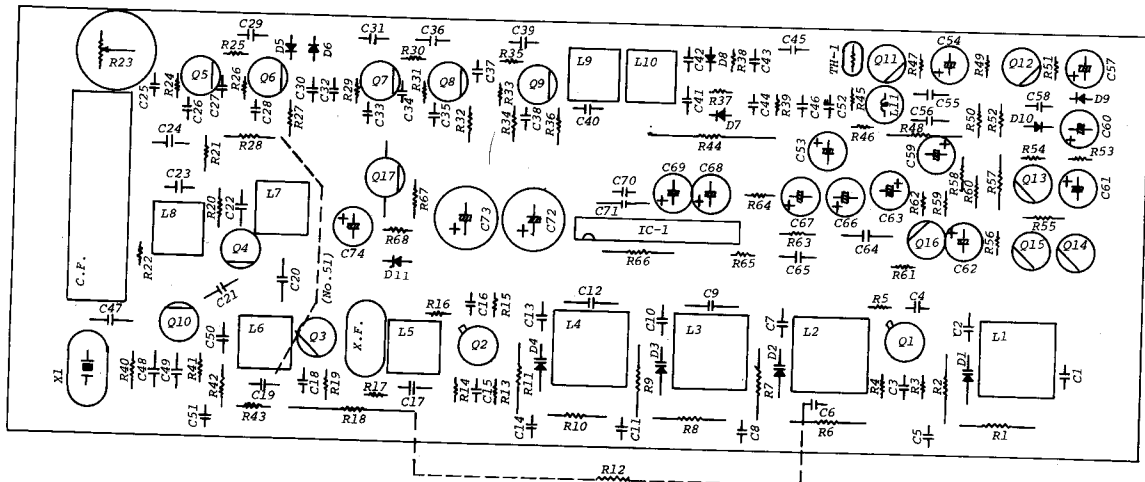

RECEIVER RX-2SX2-4

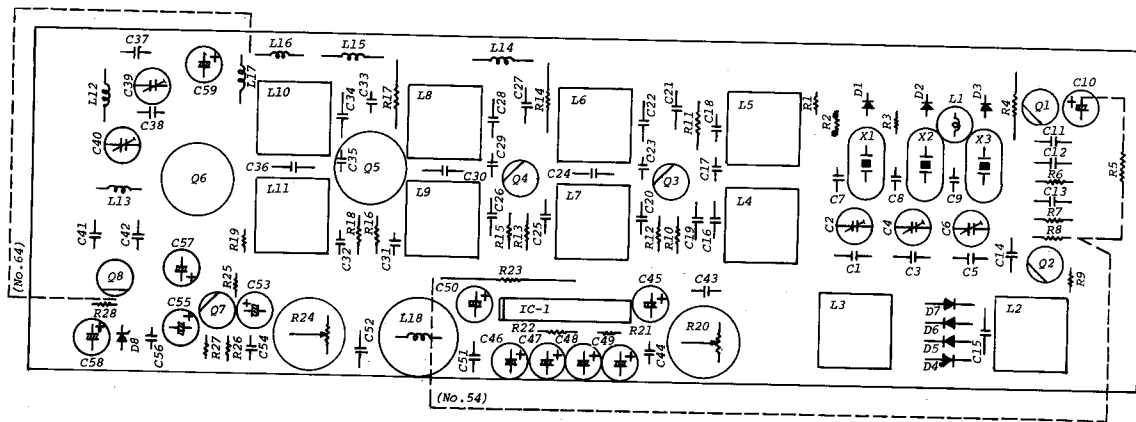

TRANSMITTER TX-2SXR2-6

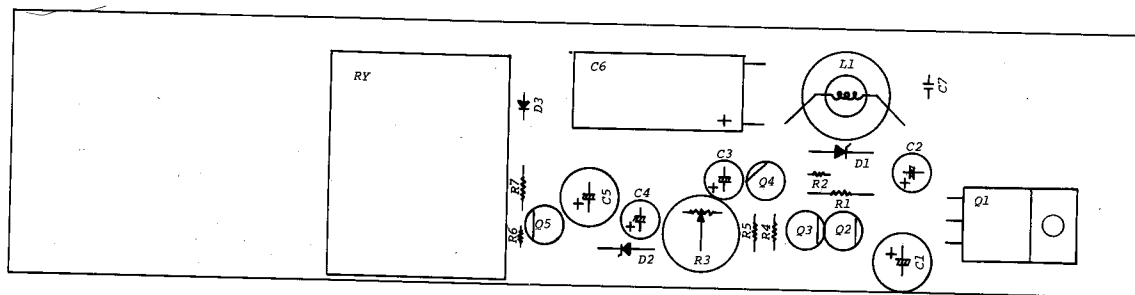

POWER SUPPLY PP-26SX2-3

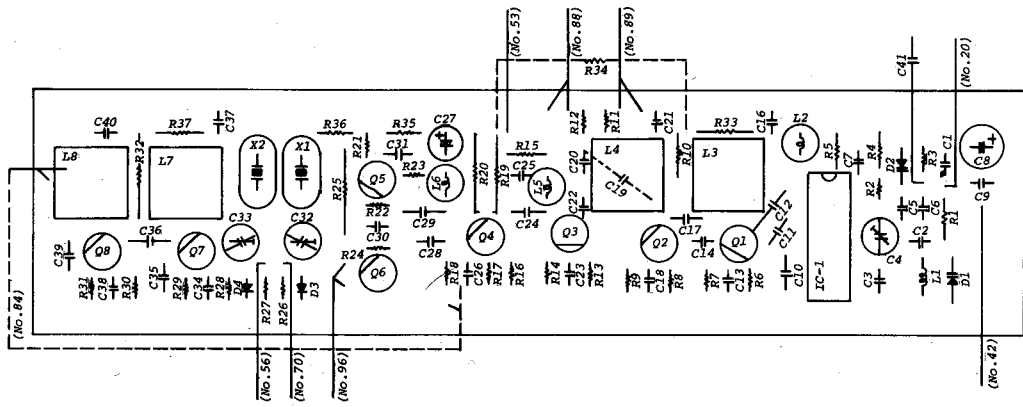

VCO-2SX2-4

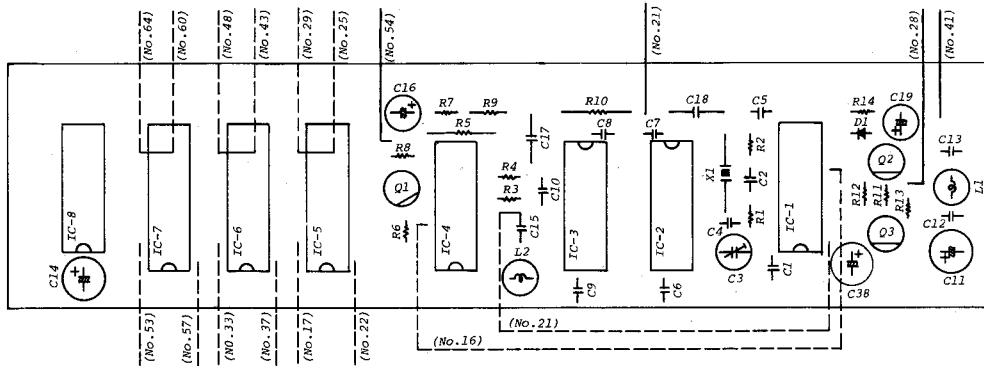

PLL-26SX2-4

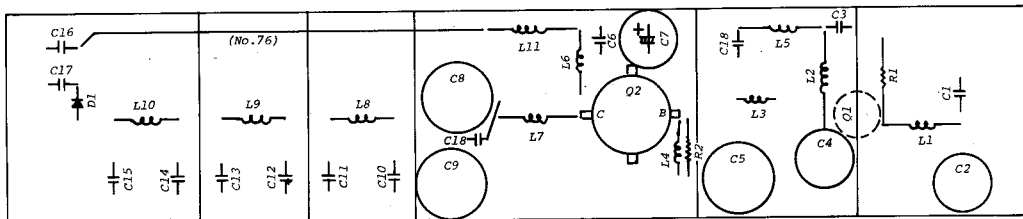

POWER BOOSTER PB10-2SX2-3

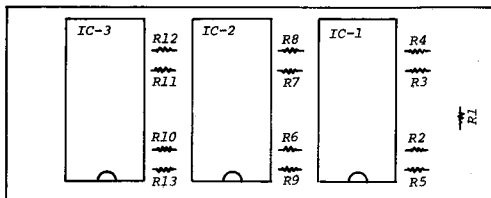

DECODER DEC-26SX2

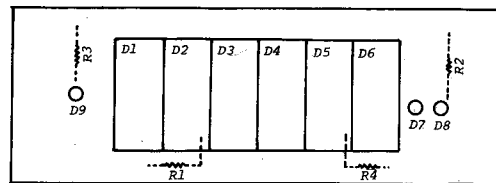

DISPLAY DSP-26SX2

8. BLOCK DIAGRAM

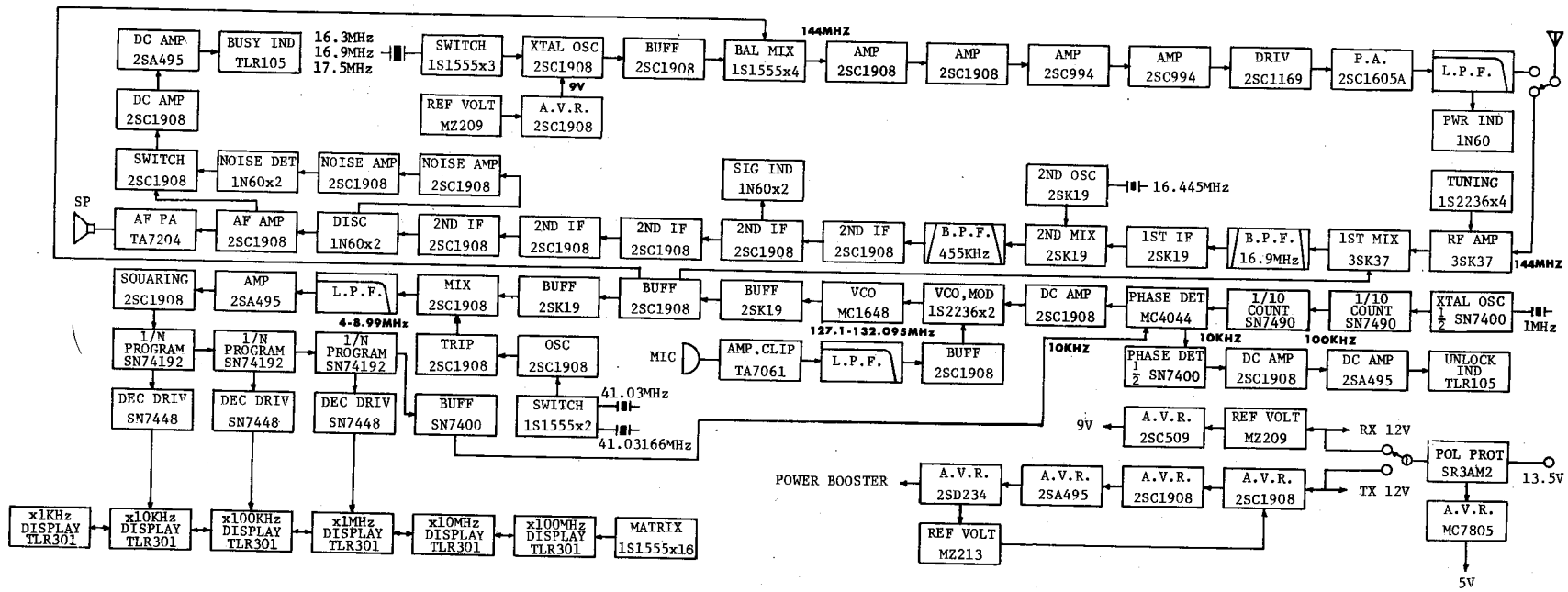

SPECIFICATIONS

KYOKUTO MODEL FM144-10SXRII

FREQUENCY COVERAGE: Receive.....144.000 - 148.995MHz
Transmit..... (a) 144.000 - 145.995MHz, or
(b) 146.000 - 147.995MHz
All above in 5KHz increments.

TYPE OF EMISSION: F-3
ANTENNA IMPEDANCE: 50 ohms, unbalanced feed.
COMMUNICATION MODE: Simplex and Duplex ± 600 KHz offset.
TEMPERATURE RANGE: 0°C to +50°C
POWER SOURCE: DC 13.5 volts $\pm 10\%$, negative ground
CURRENT CONSUMPTION: Max 4A transmit, receive .8A standby, max 1A
DIMENSIONS: 2 1/8 x 6 1/2 x 7 1/2 in. (54 x 165 x 195 mm)
NET WEIGHT: 4lbs 10oz, body only (2.1Kgs)
SHIPPING WEIGHT Approximately 6lbs 10oz (3.0Kgs)

TRANSMITTER

OUTPUT: 10 watts or better (13.5V) high power
1 watt low power by switch on microphone
OSCILLATOR CIRCUIT: IC (MC1648) voltage controlled oscillator
FREQUENCY STABILITY: 0.002%
MODULATION SYSTEM: Direct frequency modulation of VCO
VCO FREQUENCY: $f_{vco} = f_{chan} + 16.9$ MHz (duplex ± 600 KHz)
DEVIATION: ± 5 KHz (adjustable to max ± 15 KHz)
SPURIOUS RADIATION: Less than 60db below carrier

RECEIVER

RECEIVER CIRCUIT: Double conversion superheterodyne
INTERMEDIATE FREQUENCY: 1st - 16.9MHz, 2nd - 455KHz
FREQUENCY STABILITY: 0.002%
SENSITIVITY: -6dB (0.5uV) for 20dB quieting or better
SQUELCH SENSITIVITY: -10dB (0.3uV) or better
SELECTIVITY: ± 6 KHz at 6dB down, ± 12 KHz at 40dB down*
IMAGE REJECTION: Better than 60dB
AUDIO OUTPUT: 4 watts, 4 ohm load, less than 10% distortion

STANDARD ACCESSORIES

DYNAMIC MICROPHONE: 600 ohms, press-to-talk, with "HI-LO" switch
POWER CABLE: With 2 conductor connector and fuse holder, 5A
SPARE FUSE: 5A
EXTERNAL SPEAKER PLUG: Miniature phone plug type
AUTO MOUNTING BRACKET: With mounting screws, nuts and wing-bolts, etc.
INSTRUCTION MANUAL: With circuit diagram, etc.

MODEL FM50-10A SCHEMATIC DIAGRAM

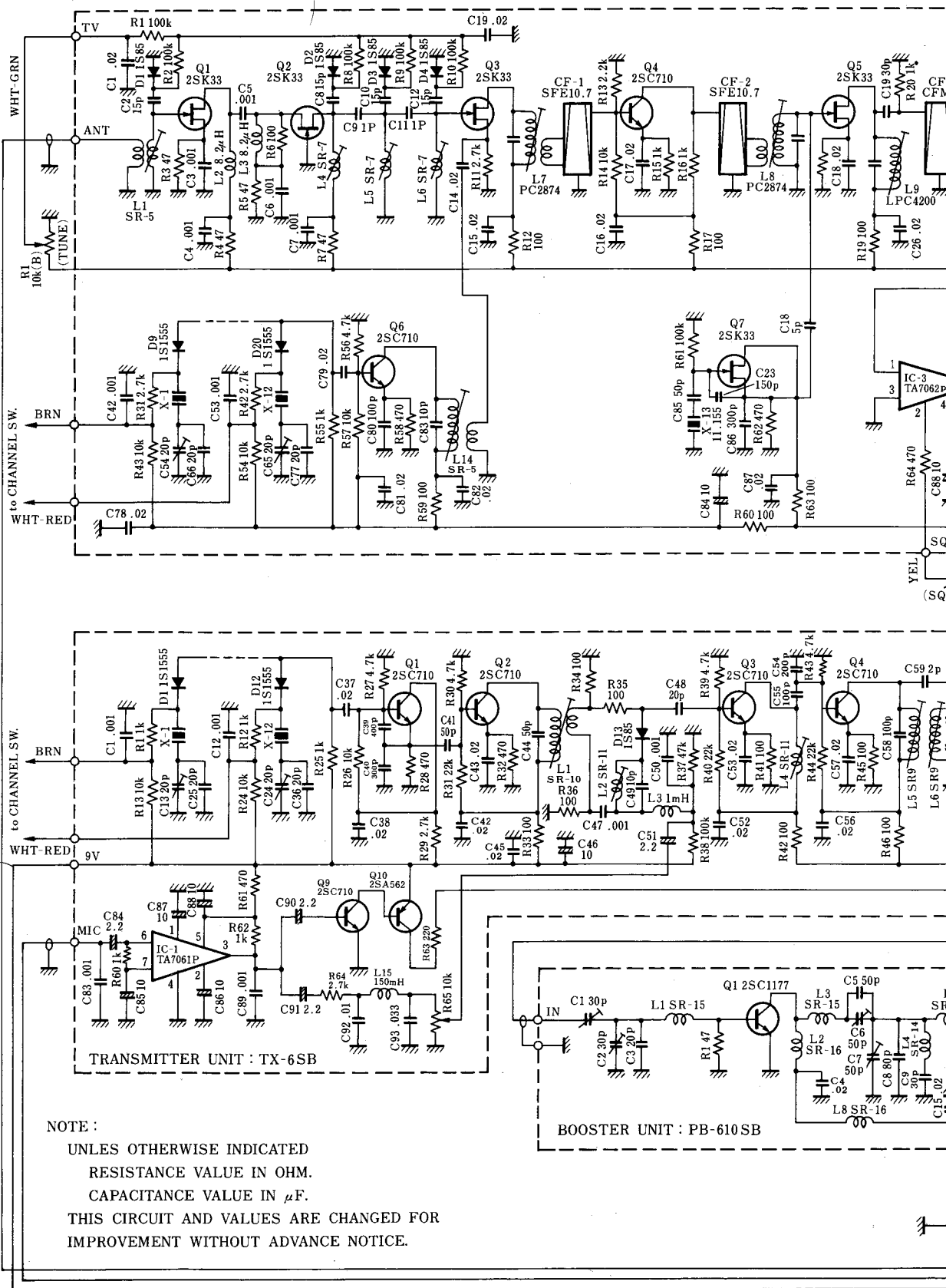

NOTE :

UNLES OTHERWISE INDICATED
 RESISTANCE VALUE IN OHM.
 CAPACITANCE VALUE IN μ F.
 THIS CIRCUIT AND VALUES ARE CHANGED FOR
 IMPROVEMENT WITHOUT ADVANCE NOTICE.

FM144-10SXR1 CIRCUIT DIAGRAM

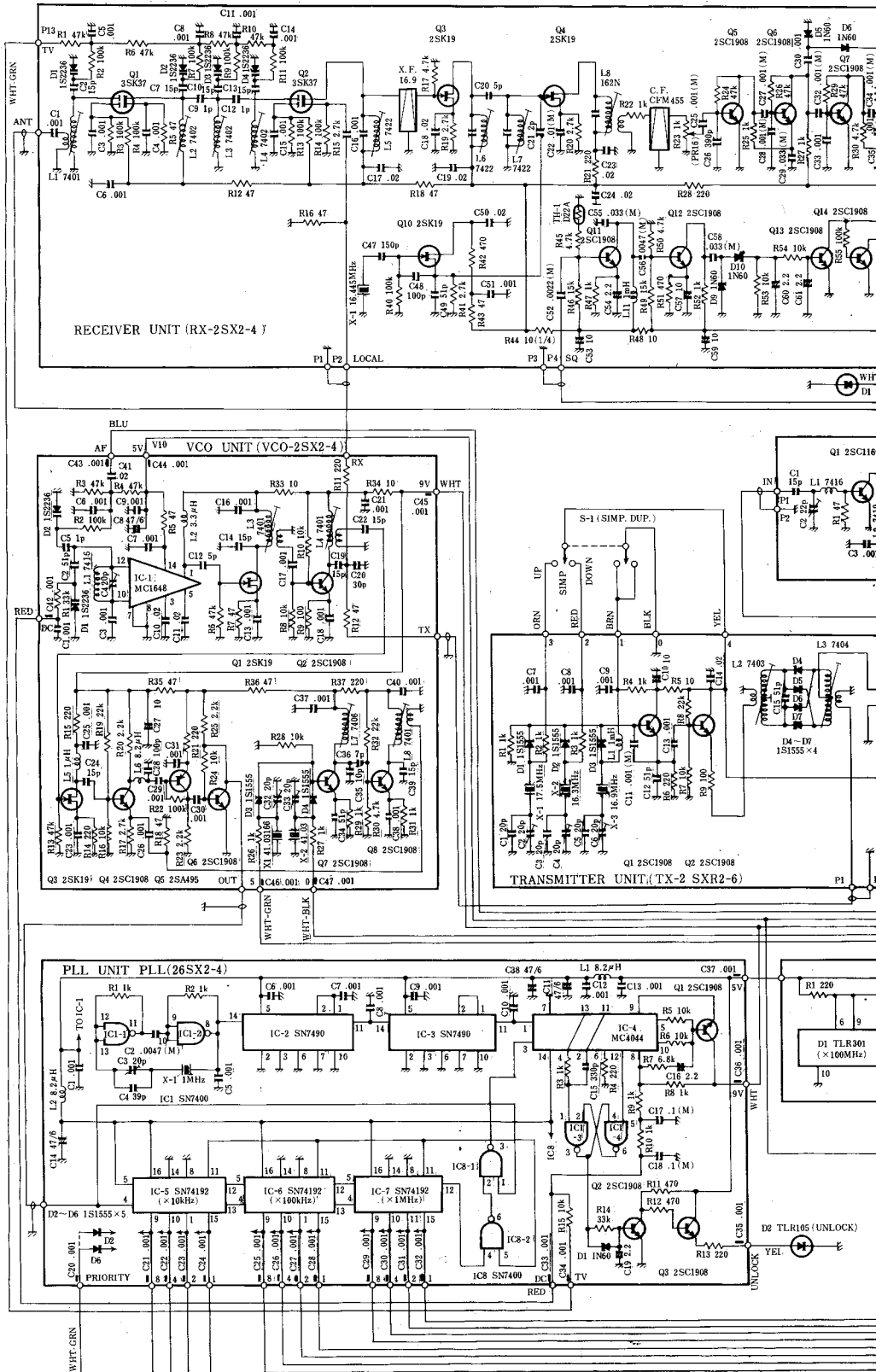

NOTE: UNLESS OTHERWISE INDICATED VALUES ARE:
 RESISTANCE IN OHMS AND CAPACITANCE IN MICRO-FARADS.
 J2 - J4 PIN NUMBERS ARE ASSIGNED AS VIEWED FROM THE REAR.
 CIRCUIT AND VALUES ARE SUBJECT TO CHANGE WITHOUT ADVANCE
 NOTICE FOR IMPROVEMENT.

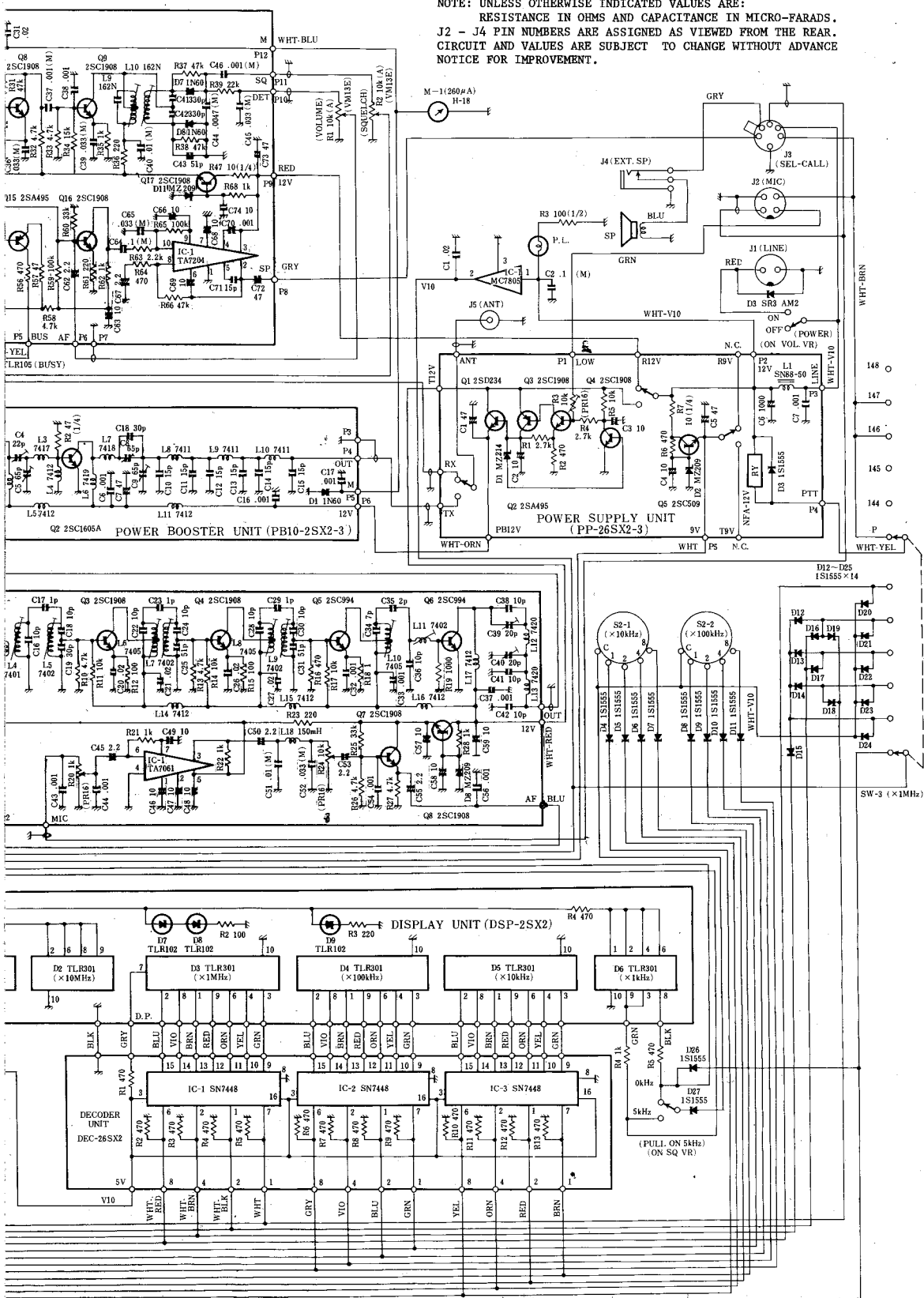

MODEL FM144-10A SCHEMATIC DIAGRAM

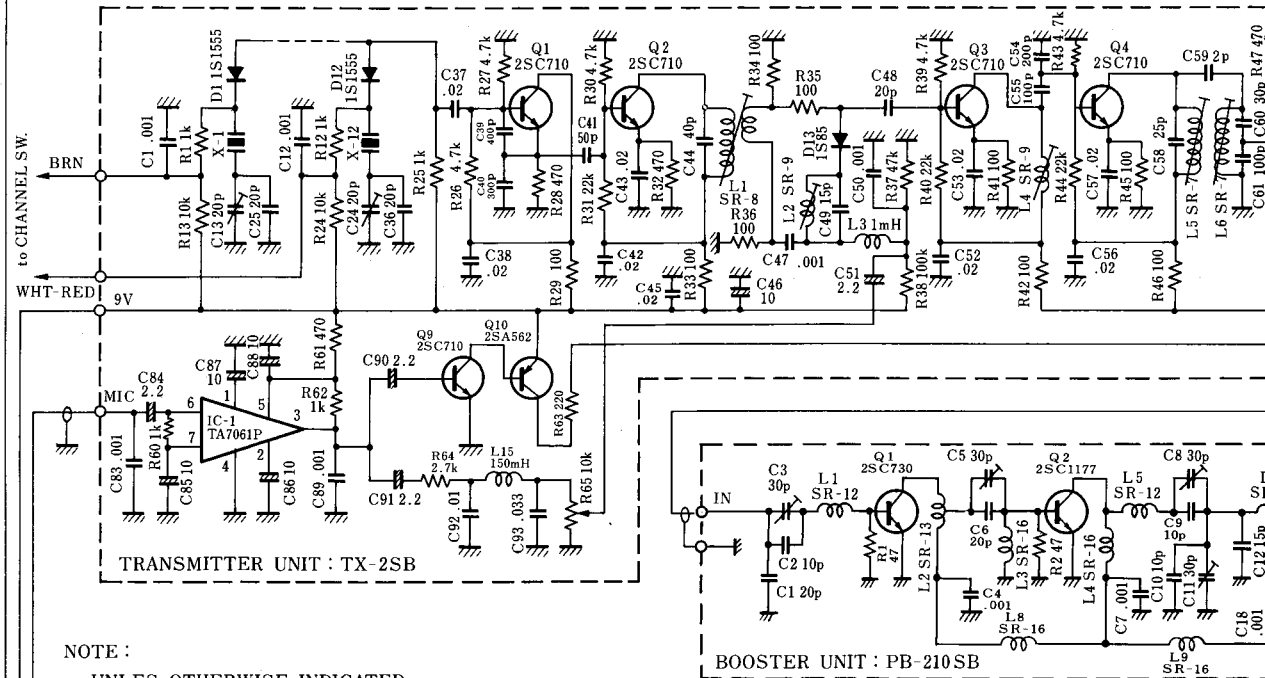
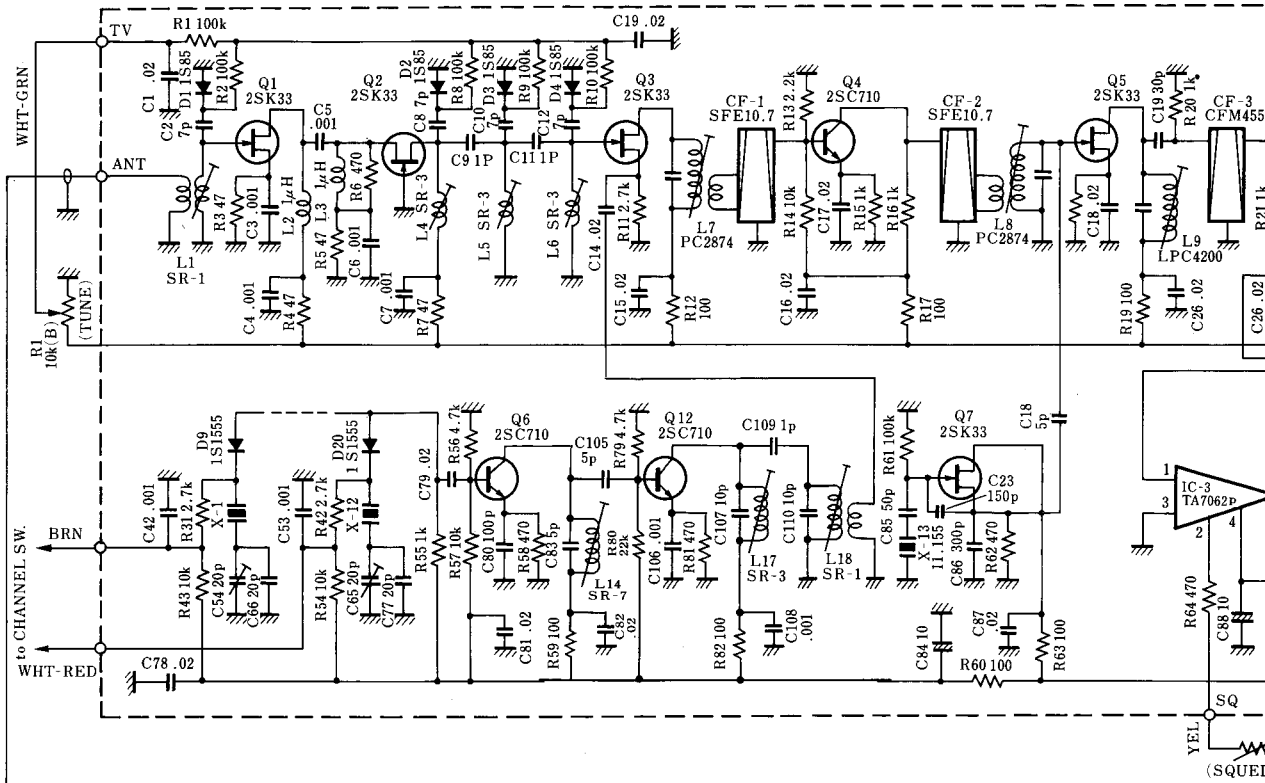

RECEIVER UNIT : RX-2SB

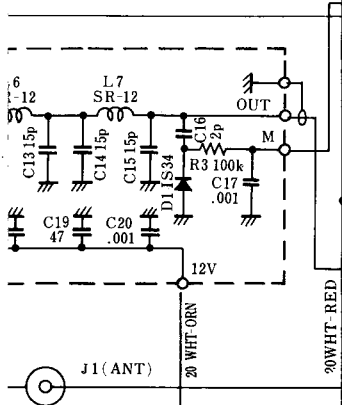
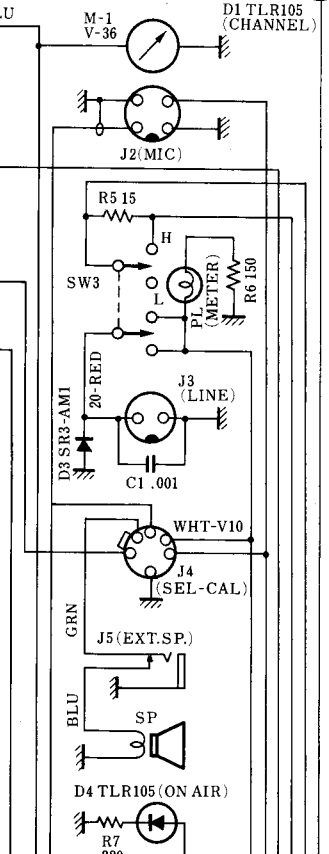
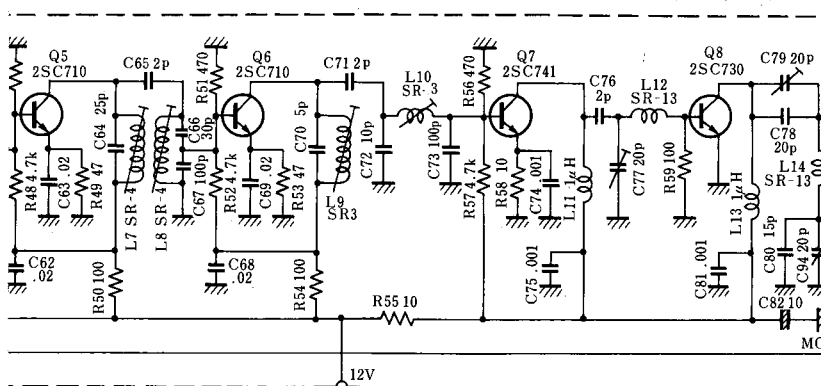
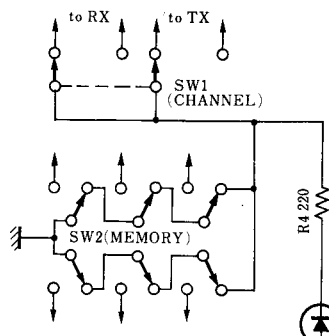
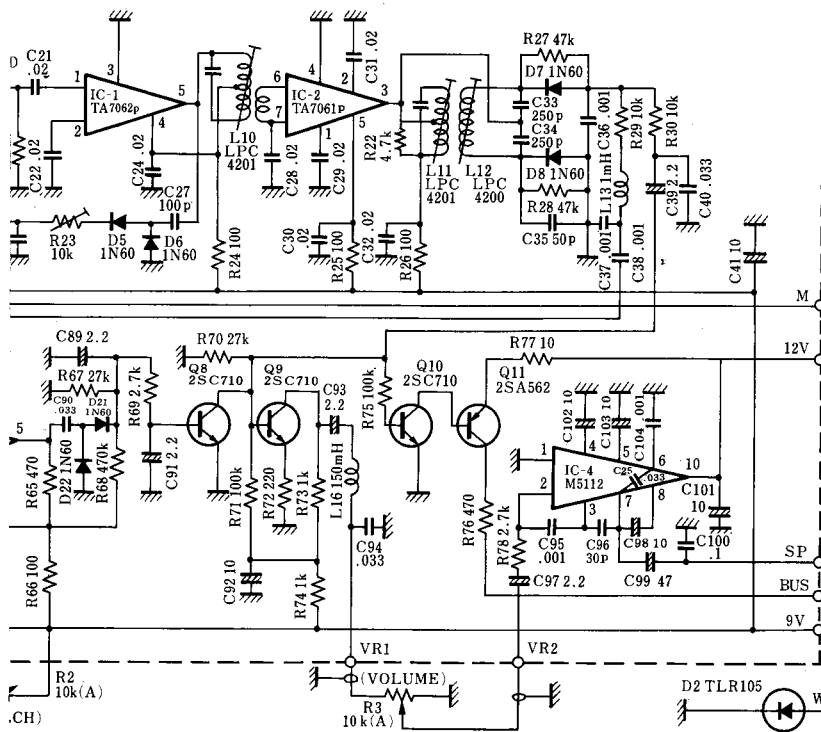

POWER SUPPLY UNIT : PP-267 SB

