

SOLID STATE 1000 CHANNEL 5KHz STEP

DIGITAL PHASE LOCKED SYNTHESIZER

2m FM TRANSCEIVER



MODEL: FM-2015R

OPERATOR'S INSTRUCTIONS



KYOKUTO DENSHI CO., LTD.

21-25, 6-CHOME, HONCHO, NAKANO-KU, TOKYO PHONE: TOKYO (382) 2681

CAUTION!!!

MEMORY BACKUP BATTERY AND WRITE SWITCH

- (1) The memory backup battery has been installed at the factory. If the transceiver is to be stored without use for an extended period, remove the battery and store in a cool location to prevent possible damage to the transceiver by corrosion, by a possibly leaking fluid from the battery.
- (2) Your transceiver is designed to keep the battery under constant charge. When installing the transceiver in a car, connect to an unswitched power source terminal so that the ignition key or any other switch does not affect the power supply to the transceiver. For fixed station use do not turn off the AC power supply. These measures will insure that the memory backup battery is always kept at full charge.
- (3) *Because of the design of the memory IC's, the frequency set up by front panel controls will be written in to memory channel number 4 EVEN IF THE MEMORY SWITCH IS OFF if the WRITE switch is accidentally operated, which will ERASE the frequency previously stored in that channel, number 4.*

TABLE OF CONTENTS

1.	GENERAL FEATURES	(1)
2.	OPERATING CONTROLS AND FUNCTIONS	(3)
3.	INSTALLATION AND OPERATING INSTRUCTIONS	(5)
4.	ADJUSTMENTS	(8)
5.	INTERNAL VIEWS	(10)
6.	COMPONENT LOCATION CHARTS	(11)
7.	BLOCK DIAGRAM	(13)
8.	GENERAL CIRCUIT DESCRIPTION	(14)
9.	SPECIFICATIONS	(20)
10.	CIRCUIT DIAGRAMS	CENTER FOLD

1. GENERAL FEATURES

YOUR KYOKUTO FM-2015R IS A VHF FM TRANSCEIVER USING THE MOST UP-TO-DATE CMOS IC DIGITAL PLL CIRCUITRY FOR MOBILE AND BASE STATION USE. IT HAS BEEN COMPACTLY DESIGNED WITH EMPHASIS ON MAINTENANCE OF HIGH QUALITY AND YET BEING EASY TO USE AND INCLUDES THE MANY FEATURES AS LISTED BELOW.

(A) FREQUENCY COVERAGE AND CHANNELS

144.000 - 148.995MHz in 5KHz steps both transmit and receive.
1000 channels. (Certain sub-types, transmit 144.000 - 145.995MHz only.)

(B) DIGITAL FREQUENCY DISPLAY

The actual operating frequency is displayed on the front panel with easy-to-read medium size LEDs making readout accurate and easy when compared to transceivers using mechanical systems or using channel numbers. Use of electronic solid-state devices insures long trouble-free life.

(C) AIRPLANE TYPE CO-AXIAL FREQUENCY CONTROLS

Three controls are used for setting up operating frequencies; the MHz switch, the 100KHz/10KHz switch and the SUP switch. The most frequently used switch, the 100KHz/10KHz control, has the two knobs located co-axially. This switch has also been made to stop at the "0" and "9" positions rather than being free running in order to make frequency changing by feel only possible. This eliminates the need to view the LEDs during mobile operations to promote driving safety, also makes this transceiver ideal for use by persons with poor eye-sight.

(D) MEMORY CHANNELS

An electronic memory system using CMOS RAMs has been adopted. Any 4 out of the 1000 available frequencies can be stored in this memory and recalled for use at any time. The use of RAM (Random Access Memory) ICs makes it possible to program or erase any frequency easily by using the WRITE switch on the front panel. A back up power source using a NICAD battery has been provided internally to retain power to the RAMs while the transceiver is disconnected from any external power source.

(E) SCANNING

A scanning system has been included to increase the utility of the transceiver. The 4 memory channels are scanned in two modes, CLOSE for locating channels in use and OPEN for locating an unoccupied channel.

(F) RECEIVER SECTION

Dual-gate MOSFETs are used as the RF amplifier and 1st mixer to provide superior sensitivity and a superior intermodulation characteristic. An electronic auto-tuning circuit using varicap diodes is designed in the RF tuned circuits to maintain sensitivity and selectivity constant over the wide frequency range covered. A monolithic crystal filter is used in the 1st IF and a 15-pole high quality ceramic filter is used in

the 2nd IF which results in achieving a superior selectivity characteristic. A ceramic discriminator is used which improves stability for the life of the transceiver when compared to the more common LC type circuitry. A RIT (Receiver Incremental Tuning) control and a discriminator meter have been added for improved operating when contacting stations with off-frequency transmitters.

(G) TRANSMITTER SECTION

The transmitter is of the single conversion type using a balanced IC mixer. It features 7 stages of peak tuned LC circuits using varicaps for electronic auto-tuning. A 4 section low-pass filter is in the transmitter output circuit and together with the electronic tuning achieves a high level of spectral purity in the transmitter output. The latest type silicon transistor is used as the final amplifier which will stand up under the extreme conditions of infinite VSWR in the load. True direct FM modulation is applied to the VCO resulting in extremely distortion-free modulation. A power selection switch (HIGH-15 watts and LOW-1 watt) is located on the front panel. Use of low power when contacting stations near-by or with good antenna locations will keep interference to adjacent stations at a minimum and promote better utilization of our precious resource, the frequencies we use.

(H) tone CIRCUITS

An internal tone generating system has been included for use in accessing repeaters. Two modes of operation are possible and selected by an internal switch and circuit constants may be changed in order to obtain the desired frequency. (A type, 67 - 203Hz and E type, 1310 - 1800Hz)

(I) MULTIPLE FREQUENCY OFFSETS

5 separate positions are available on the MODE selector switch in addition to the simplex position. Of these 2 are the normal +600KHz offsets, being labeled +600 and -600 respectively. The other three positions are labeled A, B & C and are for the installation of crystals to provide additional non-standard offsets.

(J) SEL-CALL CONNECTOR

A wired receptacle is provided on the rear panel for connection of a tone encoder/decoder unit (KYOKUTO Model SC-12A). This receptacle may be utilized for connection of a phone patch, touch-tone, remote headset/microphone combination and other similar type accessories.

(K) MODULARIZED CONSTRUCTION

The receiver unit (1), the transmitter unit (2), the transmitter booster (3), the PLL unit (4), the control unit (5), the display unit (6), the power supply unit (7) and the front panel and chassis (8) make up the complete transceiver. This modularized construction minimizes stray coupling between units in order to achieve a high level of quality and performance and facilitates servicing.

2. OPERATING CONTROLS AND FUNCTIONS

(1) SCAN SWITCH

Center position OFF. In CLOSE position, transceiver scans each of the 4 memory channels consecutively and stops at the first occupied channel. (Receives an incoming signal.) In the OPEN position scanning will stop at the first unoccupied channel. (No incoming signal being received.) Scanning is controlled by the squelch signal from the receiver, thus the squelch must be on and operating in order for the scanning to function properly.

(2) WRITE/TONE SWITCH

Center position OFF. Switching to WRITE position with MEMORY switch (10) in any of the MEMORY positions "writes in" (stores) the frequency displayed by the LED readout into the memory channel selected. This erases the frequency previously stored in that memory channel.

In TONE position, a tone signal is superimposed on the transmitter signal in one of two modes as selected by an internal switch. See G., Section 3 on page (7).

(5) MAIN POWER SWITCH

Center position - OFF. Power on in HIGH and LOW positions. Transmitter power 15 watts HIGH and 1 watt LOW.

(7a) (7b) SQUELCH/VOLUME CONTROL

Mutes receiver noises when no signal being received. Turning in clockwise direction increases depth of threshold. Volume increases when turned in a clockwise direction.

(9) MODE SWITCH

Switches from SIMP (simplex) to duplex mode for working through repeaters. Standard +600 and -600KHz offsets are available and labeled +.6 and -.6 respectively. Positions A, B and C are provided for installation of non-standard offset crystals as may be desired.

NOTE: ONLY THE RECEIVER FREQUENCIES ARE DISPLAYED BY THE LED READOUT DURING DUPLEX OPERATIONS.

(10) MEMORY SWITCH

OFF position - transceiver operates on the frequency set up by the 4 front panel controls (4a), (4b), (12) and (13), and as displayed by the LED panel, (3). Switching through the 4 memory positions selects the respective memory channels for "writing in" or "retrieving". Retrieved frequencies are then displayed on the LED readout, (3), irrespective of the setting of the other front panel frequency setting controls.

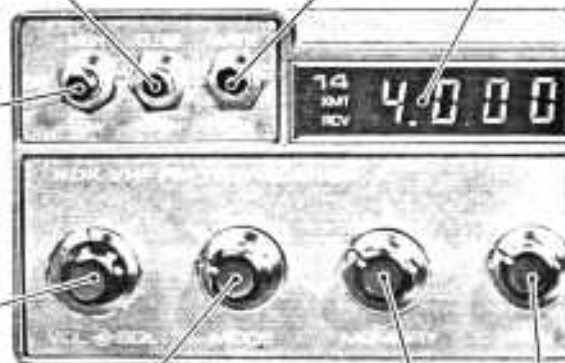

(3) FREQUENCY DISPLAY

4 digits of medium sized LED's constantly display the frequency selected by the controls (13), (4a), (4b) and (12) or memory. An XMT LED lights up during transmission and a RCV LED operates whenever a signal is received. (Squelch opens.) The RCV LED operates even when the volume control is turned completely down and serves to provide a visual indication of "channel busy" conditions. The frequency display LEDs are extinguished whenever a PLL "unlock" condition occurs.

(4a) (4b) 10KHZ/100KHZ CONTROLS

Large knob controls 100KHz digit and small knob the 10KHz digit of frequency. Will not go below 0 or above 9, in order to facilitate frequency changing while driving without needing to look at the LED display panel.

(6) SIG/PWR AND DISC METER

Indicates incoming signal strength, transmitter output and center frequency (of incoming signal). With switch (11) in S/PWR position, switches between S and PWR readings automatically. S reading calibrated to give full scale reading with input signal of +20dB(10uV). For PWR, calibrated to read approximately 8 with an output of 15 watts. In DISC position a + reading (to right of center) indicates frequency HIGH, and a - reading (to left of center) indicates frequency LOW.

(8) MICROPHONE RECEPTACLE

4 pronged receptacle to accept microphone plug.

(11) METER SWITCH

Switch to control (6); W/PWR and DISC meter.

(12) 5UP SWITCH

Controls 1KHz digit. 0KHz in OFF position and 5KHz in 5UP position.

(13) MHZ CONTROL SWITCH

Selects MHz digit, i.e., 144, 145, 146, 147, and 148MHz. (E type sets transmit 144 and 145 only.)

(14) RIT (RCVR INCR. TUNING) CONTROL

Varies receiver frequency approximately +5KHz. In cases where incoming signal is not exactly on frequency, use this control to "zero-in" the signal using the DISC meter. Center position of this control is click stopped to facilitate returning to center position.

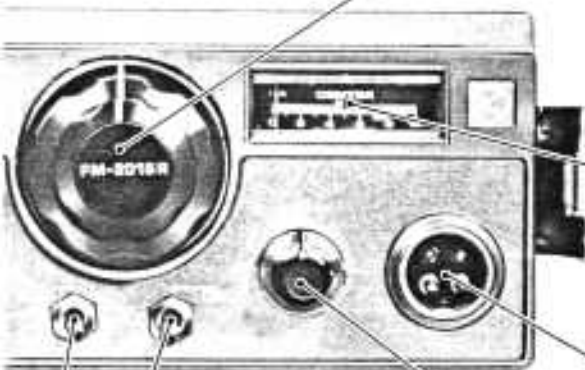

(15) ANTENNA CONNECTOR

SO-239 type connector threaded to match both inch and metric threads. Nominal impedance 50 - 72 ohms. Generally, mobile antennas tend to be of low impedance and use of 50 ohm co-ax is recommended.

(16) SELCAL CONNECTOR

5 pin "DIN" connector to connect selective calling and receiving devices such as the KYOKUTO Model SC-12A tone encoder/decoder unit. It is also convenient for the connection of phone patch, touch-tone, remote headset/microphones and similar accessories.

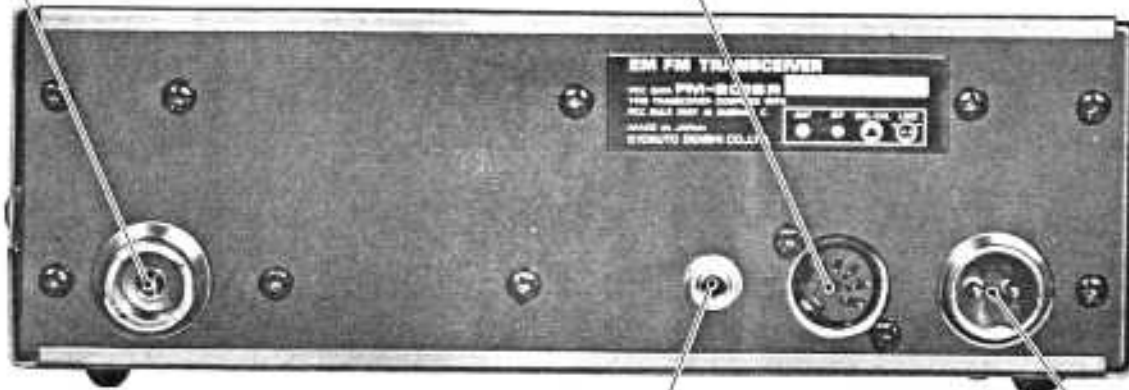

(17) EXTERNAL SPEAKER JACK

Nominal impedance 4 - 8 ohms. A relatively large size speaker of 77mm diameter is installed internally to provide good volume and tonal qualities. However, the use of an even larger external speaker will further enhance volume and quality and thus the readability of incoming signals.

(18) POWER RECEPTACLE

The 2-pin connector of power cable supplied with transceiver should be plugged in here. Connect other end of cable to 13.8VDC, $\pm 10\%$ source with negative ground. (Red - plus, black - minus.) If reverse polarity is accidentally applied to transceiver, reverse polarity protection diode should cause fuse in power cable assembly to blow. Inspect transceiver for any possible damage, and if none, replace fuse with 5A spare supplied as an accessory.

3. INSTALLATION AND OPERATING INSTRUCTIONS

1. MOBILE INSTALLATION

- A. Install the mobile mounting bracket supplied with the transceiver under the dashboard in a convenient position. The bracket is designed so that the angle of installation and fore and aft location can be adjusted and the transceiver should be secured at a position and angle for easiest operating.
- B. The antenna feedline should be connected to the antenna receptacle on the rear panel.
- C. Power should be connected to the power input receptacle using the power cable assembly furnished with the transceiver. If generator or alternator noise should be experienced, the direct connection to the battery terminals with a heavier cable is recommended. (Supply voltage should be 13.8 volts, $\pm 10\%$.)
- D. Connect microphone to the microphone receptacle on the front panel.

2. FIXED INSTLLATION

- A. Rubber feet have been provided on your FM-2015R to lift the bottom of the transceiver off the surface underneath it to prevent muffling of the sounds from the speaker. However, for ease of operating, it is frequently more convenient for the transceiver to be held so that the front panel tilts up slightly. The mobile mounting bracket furnished with the transceiver can be used for this purpose. (Brackets available optionally from your KDK dealer.) Place bracket under the transceiver and secure it to the bracket with wingbolts.
- B. Connect the antenna feedline to the antenna receptacle on the rear panel of the transceiver.
- C. Connect the power cable to the power receptacle and the other end to a suitable power supply. (Additional power cable assemblies available from your KDK dealer.) The use of a good reliable power supply of 5A capacity is recommended.
- D. Connect microphone to the microphone receptacle on the front panel.

3. OPERATING INSTRUCTIONS

- A. PREPARATION: -- Confirm that the antenna, power supply, and microphone have been connected as described in the preceding paragraphs. Now set each of the various switches and controls as follows:
 1. POWER SWITCH --- LOW
 2. SCAN SWITCH --- OFF
 3. WRITE/TONE SWITCH --- OFF
 4. VOLUME CONTROL --- Approximate center position.
 5. SQUELCH CONTROL -- Extreme counter-clockwise position.
 6. MODE SWITCH --- SIMP
 7. MEMORY SWITCH --- OFF
 8. MHZ SWITCH --- Frequency to be used.
 9. 100KHZ SWITCH --- Frequency to be used.
 10. 10KHZ SWITCH --- Frequency to be used.
 11. SUP SWITCH --- Frequency to be used.
 12. RIT CONTROL --- Center, clickstopped position.
- B. RECEIVING: -- Upon completion of the steps outlined in INSTALLATION and PREPARATION above, the METER should light up (when the power switch is switched to LOW, the frequency display should light up and display the

frequency selected and either an incoming signal or a loud rushing noise should be heard from the speaker.

1) When an incoming signal is received, the meter should register an indication based on the strength of the signal.

2) Now switch the METER switch to the DISC position. If the meter indication is displaced from the center marking, rotate the RIT control until the needle is properly centered in the meter. When receiving a weak signal, this should improve the readability of the signal being received.

3) When no signal is being received, receiver internal noises will be heard. Rotate the squelch control clockwise slowly until the noise just disappears. This establishes the squelch threshold and as soon as an incoming signal is received, it will override the squelch and be heard from the speaker. Rotating the control further to the clockwise direction will tighten the squelch which can cause some of the weak signals not being able to override the squelch and thus not heard.

- C. PROGRAMMING OF MEMORY CHANNELS: -- This transceiver has the very large capacity for operation on as many as 1000 channels. However, frequency changing to frequently used channels, particularly while driving, can be cumbersome. Thus, 4 memory channels have been provided and can be used to retain such frequently used channels. These channels should be programmed as follows:

For example, supposing that 146.52 and 3 other frequencies are to be used;

(1) Using the MHz, 100KHz, 10KHz and SUP controls set up 146.52MHz

(2) Set MEMORY switch to position 1. (As no frequency has previously been programmed in the memory, the frequency display (showing 146.52) will be extinguished as though an UN-LOCK condition existed.

(3) Operate the WRITE/TONE switch to the WRITE position and then return to the center, OFF position. As soon as this switch is set to the WRITE position, the LED display will indicate the frequency of 146.52MHz indicating that the frequency has been stored (memorized) by memory channel No. 1.

(4) Now set the memory switch on position 2. Select the next frequency desired and write in to memory using WRITE switch. Repeat this sequence for memory channels 3 and 4.

(5) Writing in a new frequency in a memory channel automatically erases a frequency previously stored in that channel.

CAUTION: Switching the WRITE/TONE switch to the WRITE position with MEMORY switch in OFF position will result in the frequency set up at the time being stored into memory channel 4. (Thus erasing any previously stored frequency in that channel.)

- D. SCANNING: -- To increase utility of this transceiver, scanning of the 4 memory channels has been provided in two modes:

1) With the SCAN switch in the CLOSE position, the memory channels will be scanned until coming to a channel with an incoming signal. In this mode scanning will then stop until the incoming signal ceases. Scanning is then resumed until the next "closed" (occupied) channel is located.

2) With the SCAN switch in the OPEN position, memory channels are scanned until an "open" (unoccupied) channel is found. Scanning is resumed as soon as an incoming signal is received on that channel.

3) Once a desired channel, either occupied or unoccupied, is located as

a result of scanning, switch the memory switch to the memory channel desired as well as switching the SCAN switch to the off position.

CAUTION: -- Do not transmit with the SCAN switch in the SCAN position. It should be noted that scanning will not stop while transmitting in the CLOSE mode of scanning. (In the CLOSE mode, the scanner is searching for a signal from the squelch circuit of the receiver -- during transmissions power is removed from the receiver, thus the squelch circuit is completely dead.) In the OPEN mode as soon as the P/T circuit is activated, scanning will stop as the scanner is searching for a lack of signal from the squelch circuit, thus as soon as power is removed from the receiver, scanning ceases only to be resumed when power is reapplied to the receiver.

E. TRANSMITTING: --

1) Selecting the HIGH position of the power switch sets up high transmitter power output (15 w). Similarly, in the LOW position power output is 1 watt. Select appropriate power as desired.

2) Depress the P/T (press-to-talk) switch on the microphone and speak into the microphone in a normal tone of voice. In the HIGH power setting, the meter should read approximately 8 for an output of approximately 15 watts. (with a 50 ohm load.) Also, the XMT indicator LED will light up while the P/T switch is depressed.

3) Releasing the P/T switch automatically returns the transceiver to the receiving mode.

F. USE OF REPEATERS (TRANSMITTER OFFSET): -- In the SIMP (simplex) position of the MODE switch, the transmitter and the receiver operate on the same frequency.

1) Setting the MODE switch to -.6 or +.6 positions offsets the transmitter frequency 600KHz lower or higher than the receiver frequency respectively. In both these positions, the LED frequency readout displays the receiver frequency continuously. Mode switch positions A, B & C have been provided for the installation of optional crystals for operation on non-standard frequency offsets.

2) Mode switch positions A, B & C have been provided for the installation of optional crystals for operation on non-standard frequency offsets. HC-18/U type crystals of the proper frequency should be installed in positions X-4, X-5 and X-6 of the transmitter unit (Model TX-2010R) on page 11. The frequency should be determined by the formula: $f\text{-crystal} = 16.9\text{MHz} + F(\text{offset})$ for repeater up, and $f = 16.9\text{MHz} - F(\text{MHz})$, repeater down. For example, for 1,080KHz up -- $f = 16.9 + 1.08 = 17.980\text{MHz}$, 700KHz down -- $f = 16.9 - .7 = 16.200\text{MHz}$. Crystal specifications are: 30pf shunt capacity and impedance not more than 15 ohms.

G. REPEATER TONE ACCESSING: -- The WRITE/TONE switch is used to superimpose a tone signal on the transmitted signal. Three modes are available.

1) A sub-audible tone (67 - 207Hz) is superimposed on the transmitter with the WRITE/TONE switch in the TONE position. (See page 7 for adjustment of frequency. "A" type transceivers.)

2) "E" type transceivers are set up ex-factory for 1750Hz tone-burst operations. An internal slide switch on the power supply PCB, selects one of two modes -- either,

- a) a 0.5 second tone burst is emitted preceding every transmission,
- b) a 1750Hz tone is transmitted every time the transmitter is keyed and the WRITE/TONE switch is placed in the TONE position.

4. ADJUSTMENTS

A. ADJUSTMENT OF RECEIVER "S" METER SENSITIVITY:

This meter has been adjusted at the factory to register approximately full scale with a +20dB (10uV) signal. When necessary, variable resistor, R-57, of the Receiver PCB should be adjusted. Clockwise direction -- increases sensitivity, and, counter-clockwise direction -- decreases sensitivity of meter.

B. "0" BALANCE OF DISCRIMINATOR METER:

Variable resistor R-60 is this adjustment. To readjust "0" setting of the meter, switch the DISC switch to the DISC position, connect pin P-13 to ground and adjust R-60 so the needle is aligned correctly with the center mark on the meter. Remove ground on P-13 after adjustment.

C. ADJUSTMENT OF MICROPHONE AMPLIFIER CLIPPING LEVEL:

Variable resistor R-40 of the transmitter PCB is this adjustment. Turning it in a clockwise direction increases output level from the microphone amplifier. Readjust this control if a different microphone is used, or when microphone inputs appears to have changed significantly. Excessive increasing of amplifier gain will result in increased clipping and increasing distortion of transmissions.

D. "0" SETTING OF RIT CONTROL:

Variable Resistor R-2 soldered to the ground side of the RIT control on the front panel (chassis section) adjusts this setting. Apply a signal to the antenna receptacle of the exact frequency as indicated by the front panel LED readout, check to see that the RIT CONTROL is in it's center clickstopped position, set the S/PWR - DISC switch to the DISC position and adjust R-2 to align the needle with the center marking on the meter.

E. ADJUSTMENT OF TRANSMITTER DEVIATION:

Variable resistor R-43 on the transmitter PCB is this control. Clockwise direction -- increases deviation, counter-clockwise direction -- decreases deviation.. Has been set for maximum deviation of +5KHz ex-factory.

F. ADJUSTMENT OF TRANSMITTER LOW AND HIGH POWER:

Variable resistor R-5 and R-4 of the power supply PCB makes these adjustments. R-5 = LOW, R-4 = HIGH. Clockwise -- increases power, counter-clockwise -- decreases power.

G. ADJUSTMENT OF TRANSMITTER POWER METER READING:

Your transmitter has been adjusted so that the meter reads approximately 8 with a power output of 15 watts into a 50 ohm load. If readjustment of this setting is required, adjust VR R-3 on the power supply PCB. Clockwise -- increases reading, counter-clockwise -- decreases reading.

H. ADJUSTMENT OF 5UP CONTROL:

Variable resistor R-40 of the PLL unit is this control. As this is one of the frequency critical adjustments do not attempt adjustment without proper experience and test instruments.

I. ADJUSTMENT OF 0KHZ CALIBRATION:

Variable resistor R-40 is calibrating the 0KHz setting. As this is one of the frequency critical adjustments do not attempt without proper experience and test instruments.

J. TONE FREQUENCY CALIBRATION:

The tone oscillator located on the power supply PCB is designed to provide either a 1750Hz tone burst, or a 67 - 207Hz sub-audible tone superimposed on the transmitter. Frequency is determined by two condensers, C10 and C9 and variable resistor R-18. Frequency range covered by R-18 versus values of C10 and C9 are tabulated below.

C10	C9	Freq. Range	Remarks
.0047mfd	NIL	1310 - 1900Hz	"E" type sets set at 1750Hz
.068mfd	NIL	90 - 210Hz	"A" type sets set at 100Hz
.068	.033	50 - 130Hz	

5. INTERNAL VIEWS

TOP VIEW

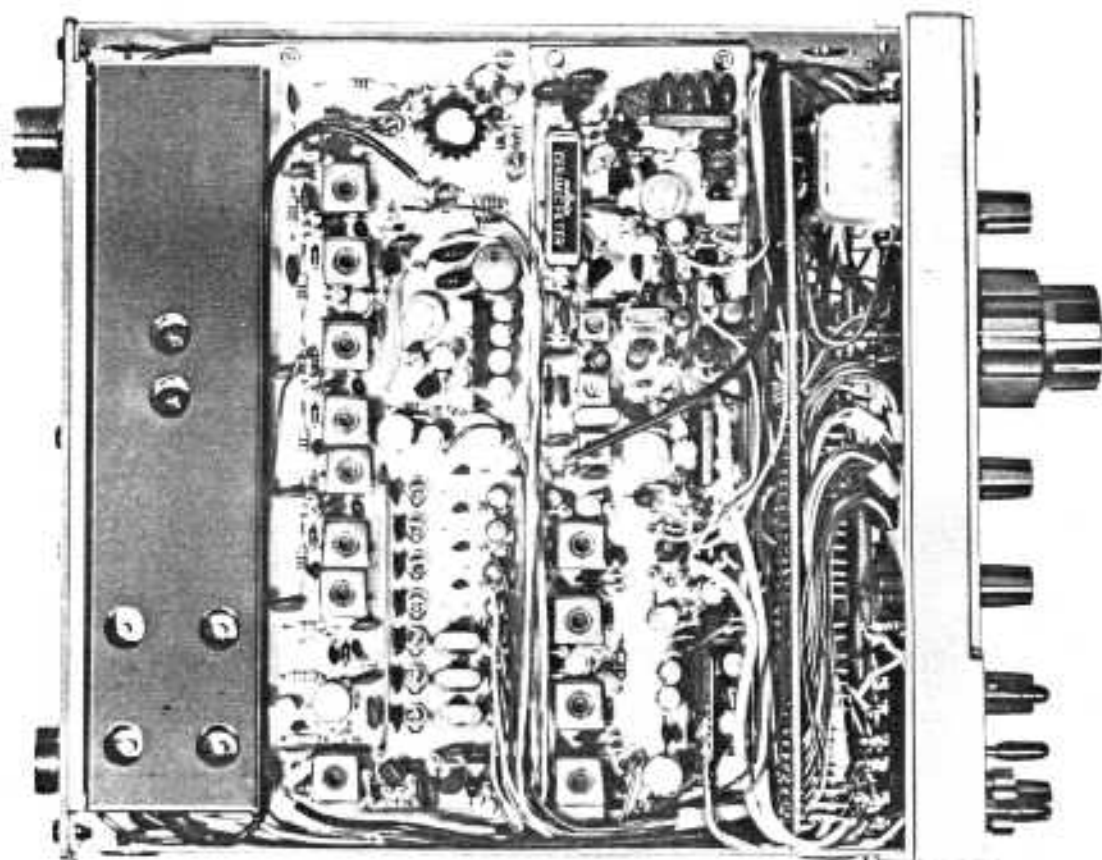

BOTTOM VIEW

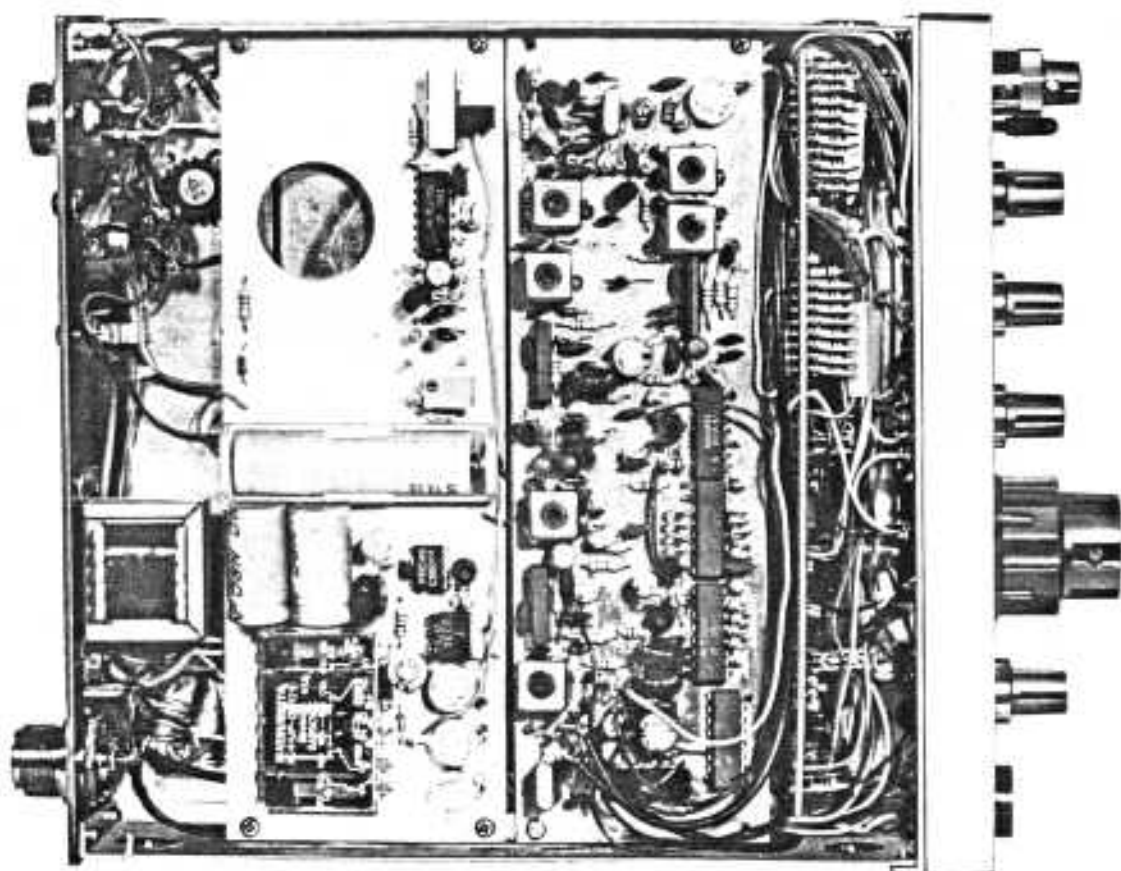

6. COMPONENT LOCATION CHARTS

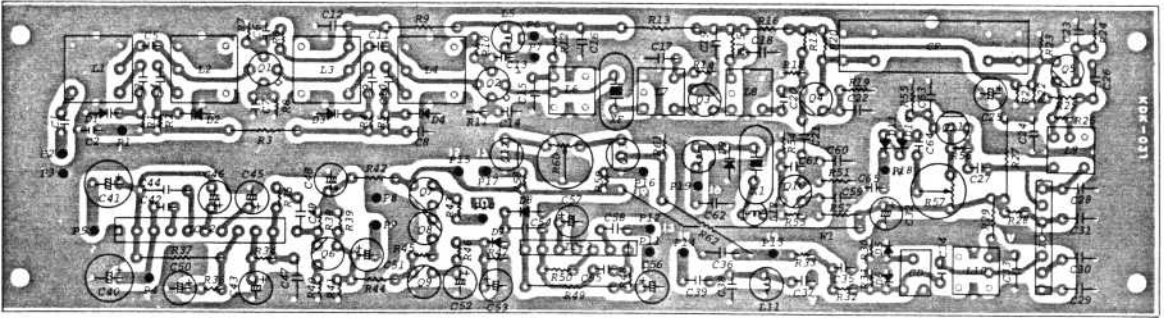

RECEIVER UNIT: Model RX-2010

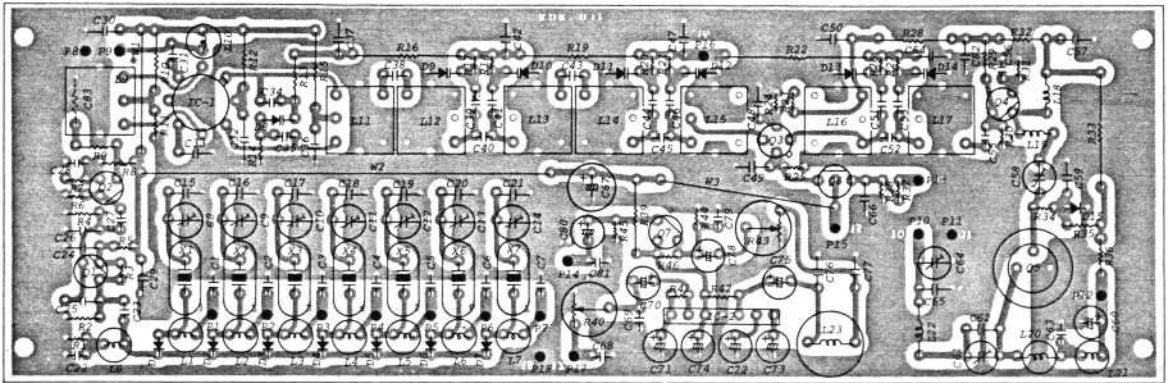

TRANSMITTER UNIT: Model TX-2010R

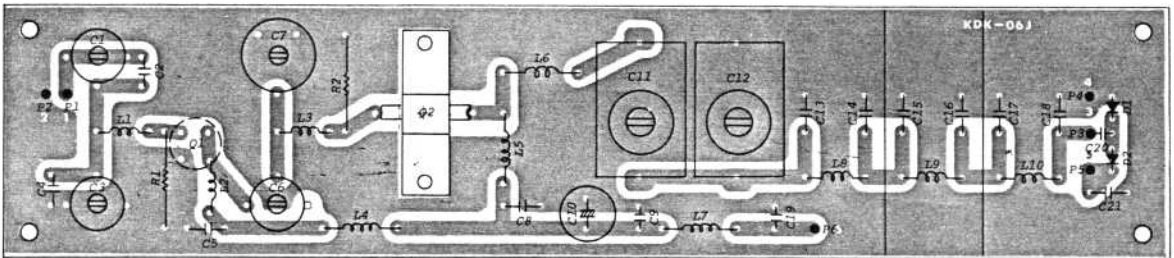

POWER BOOSTER UNIT: Model PB-2010

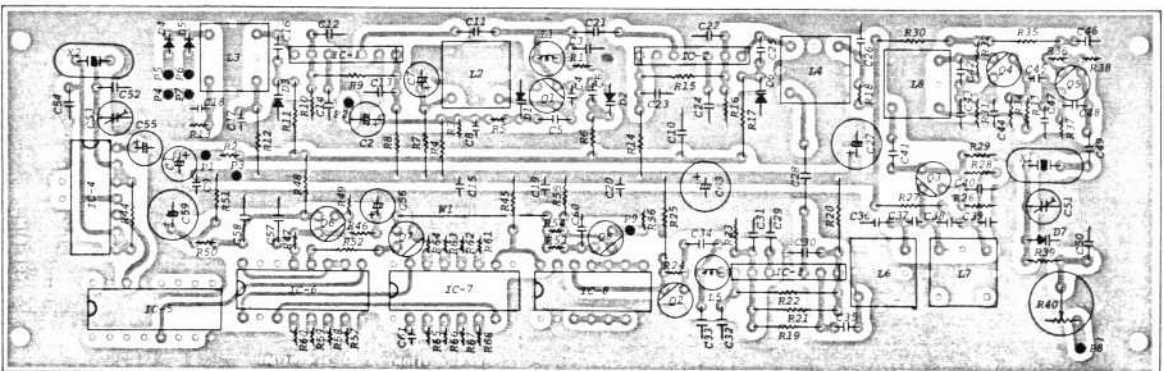

PLL UNIT: Model PLL-2010

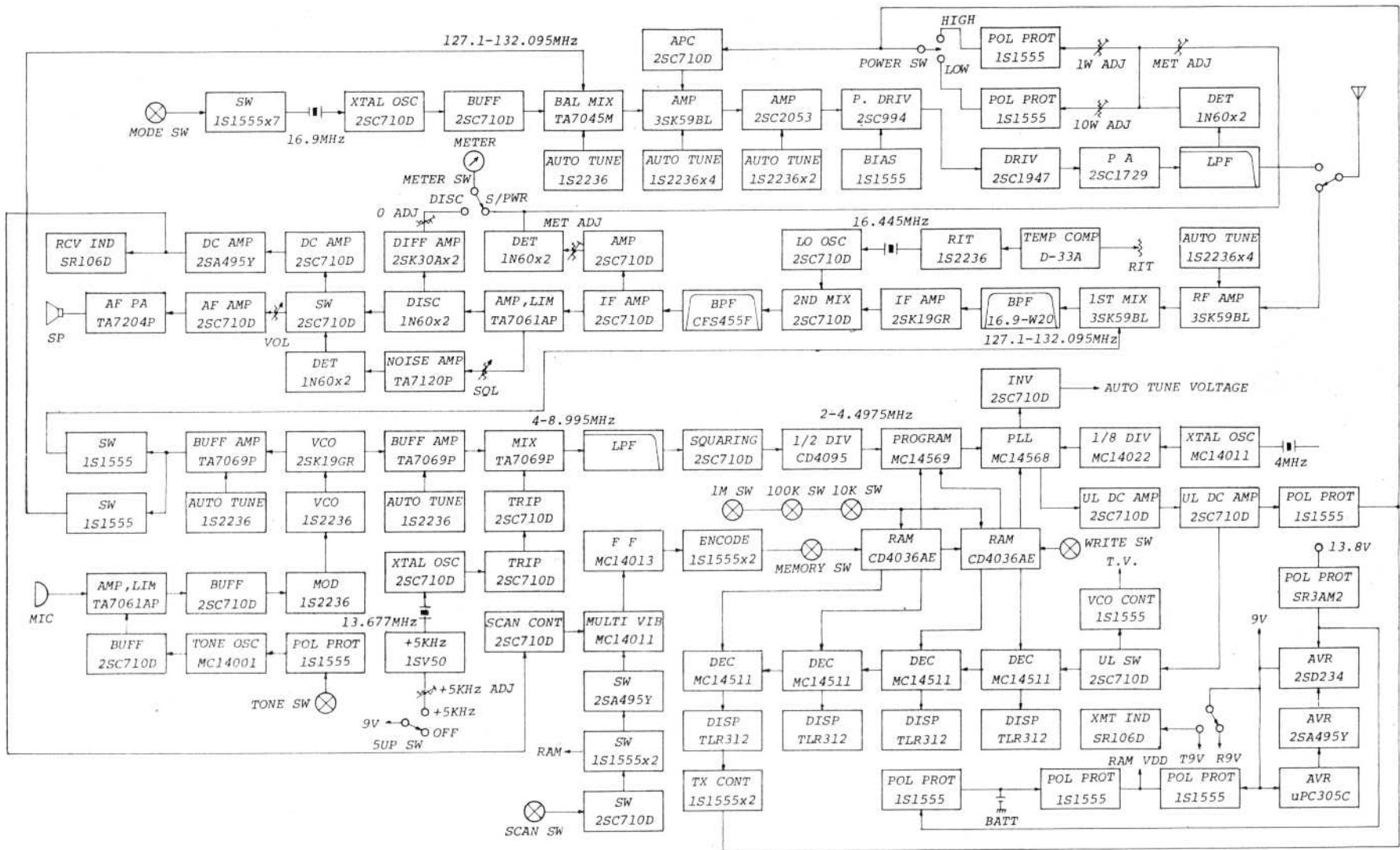

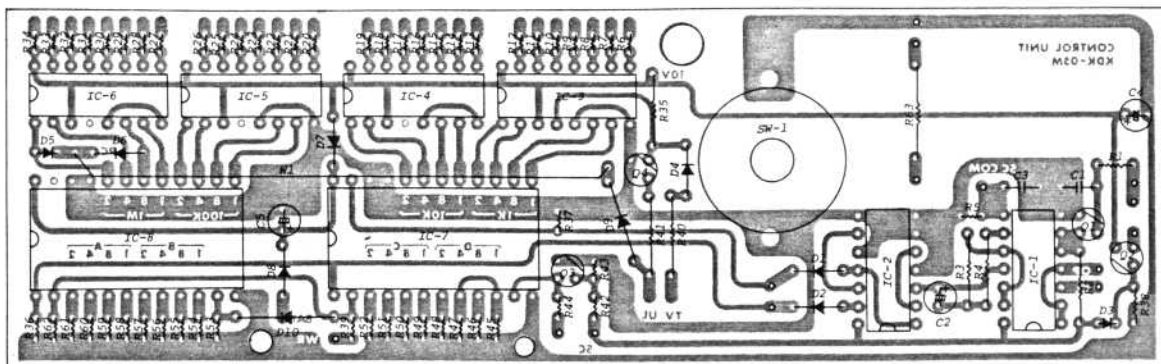

CONTROL UNIT: Model CONT-2010

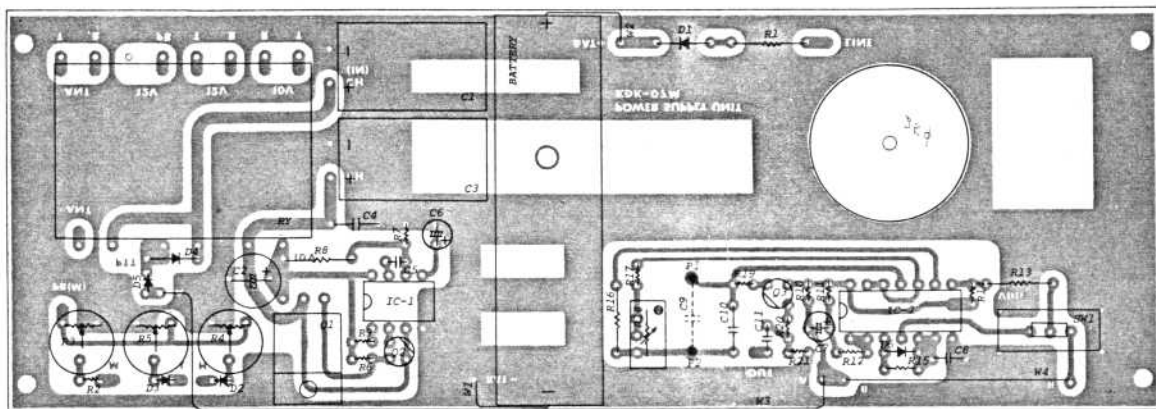

POWER SUPPLY UNIT: Model PS-2010

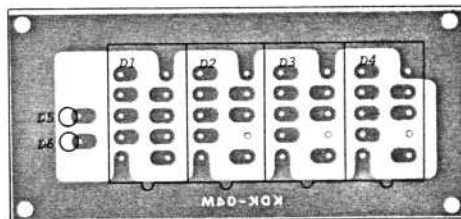

DISPLAY UNIT: Model DIS-2010

8. GENERAL CIRCUIT DESCRIPTION

1. RECEIVER UNIT: Model RX-2010

The input signal from the antenna connector passes through the change-over relay located on the power supply PCB and enters the receiver through pins P-2 and P-3. After one stage of r-f amplification by Q1, a dual gate MOSFET, the signal is passed on to gate 1 of Q2, the first mixer, also a dual gate MOSFET. The input and output circuits Q1 uses double tuned r-f circuits for elimination of cross- and intermodulation interference. These r-f circuits are further automatically peaked at the operating frequency by use of varicap diodes D1 through D4 which are fed by the automatic control voltage derived from the PLL circuit in order to maintain maximum sensitivity over the very wide 5MHz band of frequencies covered.

The 1st local oscillator voltage (127.1 - 132.095MHz) is generated by the VCO in the PLL module and is applied to Gate 2 of Q2, the mixer. The two inputs are mixed in Q2 and are thereby converted to an output of 16.9MHz which appears at the drain of Q2.

The converted signal passes through the monolithic crystal filter X.F. which has a bandwidth of +10KHz/3dB, amplified by the JFET, Q3, and fed to the base of the 2nd mixer, Q4. A signal from the 2nd local oscillator, Q10, is also fed to the base of the 2nd mixer and the signal is converted to the 2nd IF frequency of 455KHz which appears at the collector of Q4. The 2nd local oscillator circuit of Q10 is a VXO (variable crystal oscillator), and the output of this oscillator is varied approximately +5KHz by changing the voltage applied to varicap diode D9. This voltage is controlled by the "RIT" (receiver incremental tuning) control on the front panel.

The output signal from Q4 is applied to a high quality 15-pole ceramic filter with a bandwidth of +6KHz/6dB and a selectivity of +12KHz/70dB and is amplified by Q5. The output of Q5 is separated into two parts with one output being further amplified by the meter amplifier, Q11, and then rectified in a voltage doubling circuit, D10 and D11. This amplified output appears at pin P-18 which is the "S" meter terminal. The other output from Q5 is applied to IC-1 for amplification and limiting and then to the ceramic discriminator, C.D., and D5, D6 for detection. The output from the detector appears at pin P-13.

DC-output from the detector is applied to Q12 and Q13 in a JFET differential amplifier to operate the discriminator meter function and the output from the amplifier appears at pins P-16 and P-17 for connection to the discriminator meter switch and meter itself.

Noise from the cold end of L10 is picked up for the squelch circuit and is connected to pin P-14 after first passing through a low pass filter circuit.

The audio output at pin P-13 is connected to the front panel volume control and then returned to the receiver PCB at pins P-8 and P-9 and is amplified first by Q6 and then applied to the audio power amplifier, IC-2. The output from IC-2 is connected to the loudspeaker via pin P-5.

Noise output for the squelch circuit appearing on pin P-14 is returned to pins P-11 and P-12 after passing through the squelch control on the front panel. This noise is amplified by IC-3 and then rectified in a voltage doubling circuit made up of D7 and D8. The d-c output from this rectifier switches transistor Q9. The d-c output from Q9 is fed to the base of the audio amplifier, Q6, and mutes the amplifier in accordance with the setting of the squelch control. This output of Q9 is also further amplified by Q8

The output from the frequency standard is subdivided until it reaches 5KHz where it is then fed to the phase detector. The phase detector compares these two signals and outputs a control voltage. When the output of the VCO is lower in frequency than the subdivided output of the frequency standard, the phase detector's control voltage output is lowered, and when in reverse the VCO output is higher than the standard, the control voltage is raised.

This control voltage is fed to the VCO in order to raise or lower it's frequency so that it matches the frequency standard's output. The synthesizer is said to be "locked" when these frequencies are matched, and "unlocked" when the frequencies are not matched.

The output frequency of the synthesizer is controlled by varying the dividing ratio of the program counter. For example, a dividing ratio of 1/400 results in an output frequency of 144.000MHz, and a ratio of 1/500 gives an output of 145.000MHz. Set-up of the dividing ratio of the programmable counters in this set is accomplished through C-MOS RAM IC's which provide 4 channels of electronic memory which can be programmed or erased at will from the front panel controls. Two 8-bit 4 word RAMs are utilized which provides 4 such memory channels.

A scan oscillator is included which outputs a scanning signal to the address lines of these memory channels and switches the RAMs progressively to provide full scanning of the memory channels. In addition to controlling the programmable counters, the output of the RAMs are also fed to the decoder IC's which in turn drive the front panel display LEDs.

5. CONTROL UNIT: Model CONT-2010

FREQUENCY SET UP AND CONTROL: -- The frequency control switches establish the dividing ratio for the programmable counters in BCD code which is fed to the RAMs, IC-7 and IC-8. Pin P-11 of the RAM is the memory bypass terminal. When this terminal is in the "H" state, input to the IC appears directly at the output terminals. Information stored in the memories are not affected and thus the data input (BCD coded) is outputted to diodes D1 - D4 and from there inputted to the BCD to 7 segment decoders, IC-3 through IC-6, which in turn provides outputs to the LEDs to drive their segments "a" through "g" respectively, and thus provide a display of the operating frequencies. Pin 4 of the decoder ICs are the "blanking" terminals and are used to blank out the displays when an "UNLOCK" condition exists. An "H" signal from the PLL is inverted to a "L" signal by Q4 for application to Pin 4 for this purpose. Another signal is fed to the APC (automatic power control) terminal through D9 to inhibit transmissions when an "unlock" situation exists. In the same manner, diodes D5 and D6 inhibit the transmitter when frequencies in the 146 through 148MHz bands are selected. (E type transceivers only.) Diode D4 is provided to pull back the VCO frequency to a controllable range whenever the VCO frequency rises beyond controllable limits. This is accomplished by lowering the voltage on the T.V. terminal.

MEMORY: -- When the memory switch is turned to the MEMORY position from the OFF position, an input is applied to the address terminals, pins 1 and 23, of the RAMs, IC-7 and IC-8, through the switching transistor, Q2. Turning the Write/Tone switch to WRITE at this point changes the voltage on pin 2 of the RAMs (the "Write" terminal) from "L" to "H". Pin 11, the MB terminal also becomes "H" and thus the input signal is written in (stored) in the memory channel selected, by the memory switch, and is also outputted from the output terminals of the RAMs. Operating modes of the RAMs are illustrated in Table I.

CONTROL INPUT				OPERATIONAL MODE
	EH 21	MB 11	CH 23	
L	X	H	L	Data input appears at output, memory content does not change.
H	X	H	L	Data input is stored in memory, also appears at output.
		L	L	Writing in is prohibited, and memory contents is outputted.

TABLE I RAM IC OPERATIONAL MODES

SCANNING: -- IC-1 is the scanning oscillator and is a QUAD 2-Input NOR Gate IC which operates as a multivibrator together with IC1-3 and IC1-4, and outputs pulses in accordance with the time constants established by R3 and C2. This pulse drives flip/flop IC-2 whose output switches the address lines of the RAMs, thus scanning the memory channels. A signal from the receiver squelch circuit is used to control the multivibrator IC1-3 through Q1, IC1-1 and IC1-2 controlling the starting and stopping of the multivibrator. During scanning, switching transistor Q2 prohibits memory and Q3 prohibits "writing."

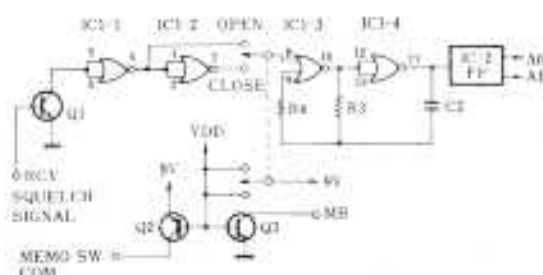

FIG. 2 SCANNING

6. PLL UNIT: Model PLL-2010

The transmitter and receiver local oscillator signal, 127.1 - 132.095MHz, is generated directly by a self oscillator, the VCO. This is Q2, a J-FET and the frequency of oscillation is controlled by the values of L2, C5 and the varicap diode, D2.

A control voltage is obtained from the phase detector and applied to D2 to vary it's capacity in order to achieve a stable output frequency. Another varicap, D1 is in parallel with this oscillator circuit through C5 which is fed the modulation signal received through pin P-2 of the module and by varying the voltage on D1 achieves direct frequency modulation of the VCO. Output from the oscillator is fed through C11 to a cascode isolation amplifier, IC-1 and is outputted to pins P-4 and P-5 through switching diode D4, as the 1st local oscillator signal for the receiver, and also through diode D5 to pins P-6 and P-7 as the transmitter local oscillator output. The

output from the VCO is also fed through another cascode amplifier IC-2 through C21 and is then applied to the mixer, IC-3. Q5, a VXO, (variable crystal oscillator) oscillates at a frequency of 13.677MHz which is tripled by Q4, again tripled by Q3 to achieve an output of 123.100MHz. This output is fed to the mixer, IC-2 to mix with the VCO signal to obtain an output of 4.000 - 8.995MHz. A varicap diode, D7, together with L9 controls the frequency of oscillation of the VXO. VR R43 controls the voltage applied to D7 and thus its capacity to set the VXO at exactly 123.105MHz. VR R40 changes the voltage on D7 by 10 volts when the 5UP switch is operated to change the VXO frequency to 123.100MHz and thus change the output of the mixer, IC-2 from 4.000MHz to 3.995MHz and thus change the last digit of the operating frequency of the transceiver from 0KHz to 5KHz. The output from the mixer IC is applied for wave shaping to transistor Q2 through a low pass filter to remove spurs. The output from Q2 is applied to the programmable counters. However, as the MCL4569 RAM units have a maximum operating frequency of 8MHz only, this output is divided by 2 by a high speed C-MOS flip/flop, IC-8, to obtain an output of 2.000 - 4.4975MHz for applying to the programmable counters through the RAMs. IC-7 is an LSI with 2 digits of BCD programmed counters which is used for the 10KHz and 100KHz digits of frequency control, and IC-6 has a programmable counter which is used for the MHz digit. IC-6 is an LSI containing a programmable counter, a phase detector, dividing circuits for the frequency standard and the programmable counter is connected internally to the phase detector. A frequency standard, IC-4 and X2 generates a 4.000MHz signal. This is divided by 8 by IC-5 to obtain a 500KHz standard. This signal is fed to the internal divider, of IC-6 which further divides it down to 5KHz. The phase detector compares 5KHz subdivided output from the programmable counters and the 5KHz standard signal and detects whether the phase difference is advancing (frequency is high) or retarding (frequency is low), and outputs an "H" or "L" signal from its output terminal, pin 13. This output is inverted by transistor Q6 and applied to D2, the VCO. This control voltage is also outputted from the module through pin P-1 for automatic electronic tuning of the receiver and transmitter modules. A second phase detector is contained in IC-6 which outputs an "Unlock" signal to pin 12. This signal is d-c amplified by transistors Q7 and Q8 and is used for transmitter inhibiting and display blanking through module pin P-9.

The interior structures of IC-6 and IC-7 is illustrated in Figs. 3 and 4.

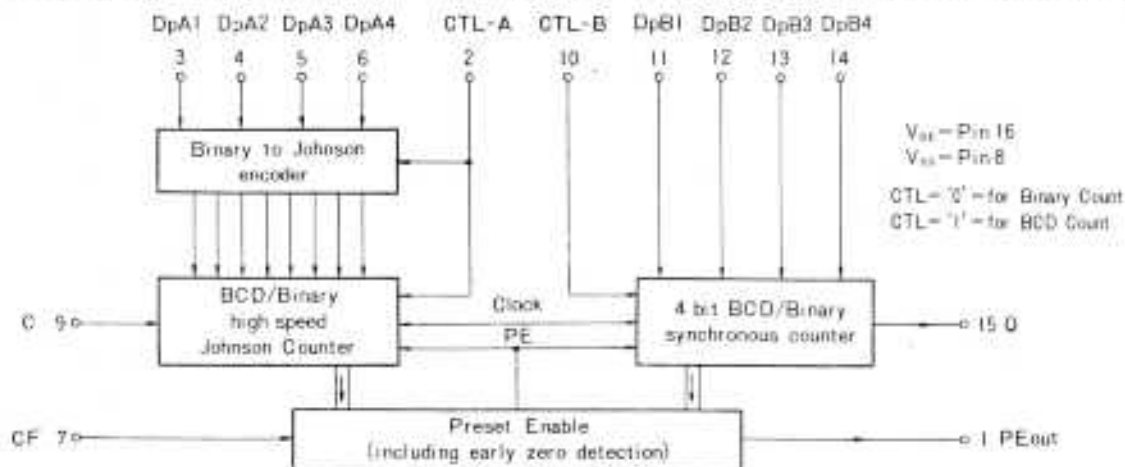

FIG. 3 MC 14569 BLOCK DIAGRAM

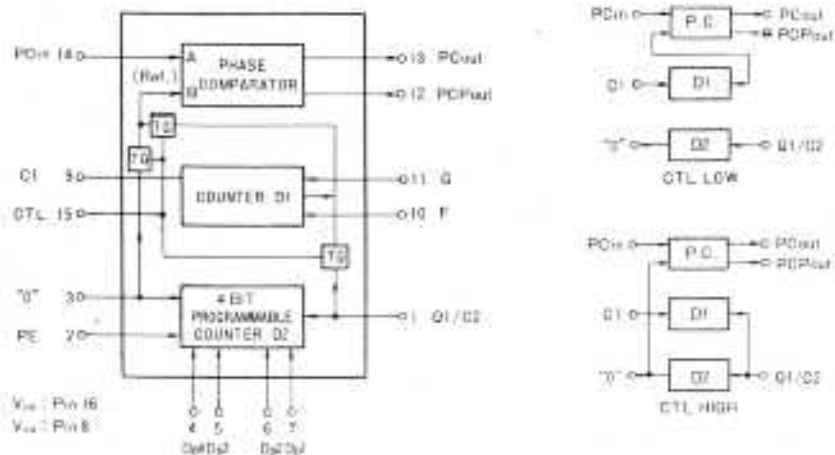

FIG. 4 MC14568 BLOCK DIAGRAM

7. POWER SUPPLY UNIT: Model PS-2010

The power supply module contains a 10 volt regulated supply, the antenna changeover relay, power output control circuitry, transmitter power meter control and the tone oscillator circuits.

D-C input to the module enters through the CH terminal and is regulated by the AVR IC, IC-1. The 10V output from the regulator is fed to the respective circuits through current booster transistors, Q2 and Q1. VR R3 in this module, controls the reading of the transmitter power meter, R4 the transmitter output in the HIGH mode and R5, the transmitter output in the LOW mode.

IC-2 is the tone oscillator. It's frequency is determined by values of R17, R18, C9 and C10. It's output is applied to the microphone input terminal through transistor, Q3. Operating mode of the oscillator is controlled by slide switch, SW1. These are, a) a continuous tone emitted while the WRITE/TONE switch is in the TONE position, or b) a .5sec pulse transmitted preceding every transmission, i.e., each time the microphone P/T switch is operated. a) is for sub-audible tone system -- leave Write/Tone switch in TONE position for duration of the contact and manually controlled tone burst -- press down on P/T switch and then operate Write/Tone switch to TONE for approximately 1 second and then return to off, and b) is for automatic tone burst -- leave Write/Tone switch in TONE position for duration of the contact.

GENERAL

FREQUENCY COVERAGE: 144.000 - 148.995MHz in 5KHz steps (1000 channels)
SEMI-CONDUCTORS: FET - 7, Transistors - 30, IC - 23, Diodes - 73, Thermistors - 1
MEMORY CHANNELS: 4 Channels
SCANNING: Scanning of above 4 memory channels for open and closed channels
FREQUENCY STABILITY: Better than .002%
TEMPERATURE RANGE: -20° -- +60°
POWER SOURCE: DC 12.0v -- 15.5v
GROUNDING: Negative ground
ANTENNA IMPEDANCE: 50 ohms nominal (unbalanced feed)
CURRENT CONSUMPTION: Receive, no signal -- less than 0.4A
" max. output - less than 0.7A
Transmit -- Less than 3A (High output)
Less than 1.5A (LOW, set to 1 watt)
DIMENSIONS: 180mm (186) wide, 80mm high and 195mm (240) deep.
(Figures in parenthesis protruding points)

TRANSMITTER

FREQUENCY COVERAGE: 144.000 - 148.995MHz in 5KHz steps (See NOTE 1 below)
TYPE OF EMISSION: F3
POWER OUTPUT: 15watts (HIGH), 1 watt (LOW)
MODULATION CIRCUIT: Reactance Modulation (direct varicap FM of VCO)
MAXIMUM DEVIATION: +5KHz
SPURIOUS EMISSIONS: More than 60dB down from carrier
MICROPHONE: 500 ohms, press-to-talk, dynamic microphone
REPEATER TONE ACCESS: Adjustable 67 - 207Hz or 1310 - 1800Hz (See NOTE 2 below)

RECEIVER

FREQUENCY COVERAGE: 144.000 - 148.995MHz in 5KHz steps
TYPE OF EMISSION: F3
RECEIVER CIRCUIT: Double Superheterodyne
INTERMEDIATE FREQUENCIES: 1st ~ 16.9MHz, 2nd - 455KHz
RECEIVER SENSITIVITY: Better than 35dB S/N at 1uV
Less than 0.25uV for 20dB quieting
SQUELCH SENSITIVITY: Better than 0.2uV
BANDWIDTH: +6KHz (6dB down)
SELECTIVITY: +12KHz (70dB down)
IMAGE RATIO: Better than 70dB
AUDIO OUTPUT: More than 4 watts (4 ohm load, 1KHz, 10% THD)

ACCESSORIES

MICROPHONE, dynamic type, 5000 ohms with P/T switch
POWER CABLE, with fuse holder and 2 prong metal connector
SPARE FUSE, 5A
EXTERNAL SPEAKER PLUG, miniature phone plug type
MOUNTING BRACKET, with mounting hardware, etc.
INSTRUCTION MANUAL, with circuit diagram

NOTE 1. "A" type sets, full 5MHz transmitter coverage
"E" type sets, transmit 144.000 - 145.995MHz only

NOTE 2. "A" type sets tone oscillator set at 100Hz at factory
"E" type sets tone oscillator set at 1750Hz at factory

MODEL : FM-2015R CIRCU

OVERALL INTERCONNECTION Schematic Diagram(Chasis Section)

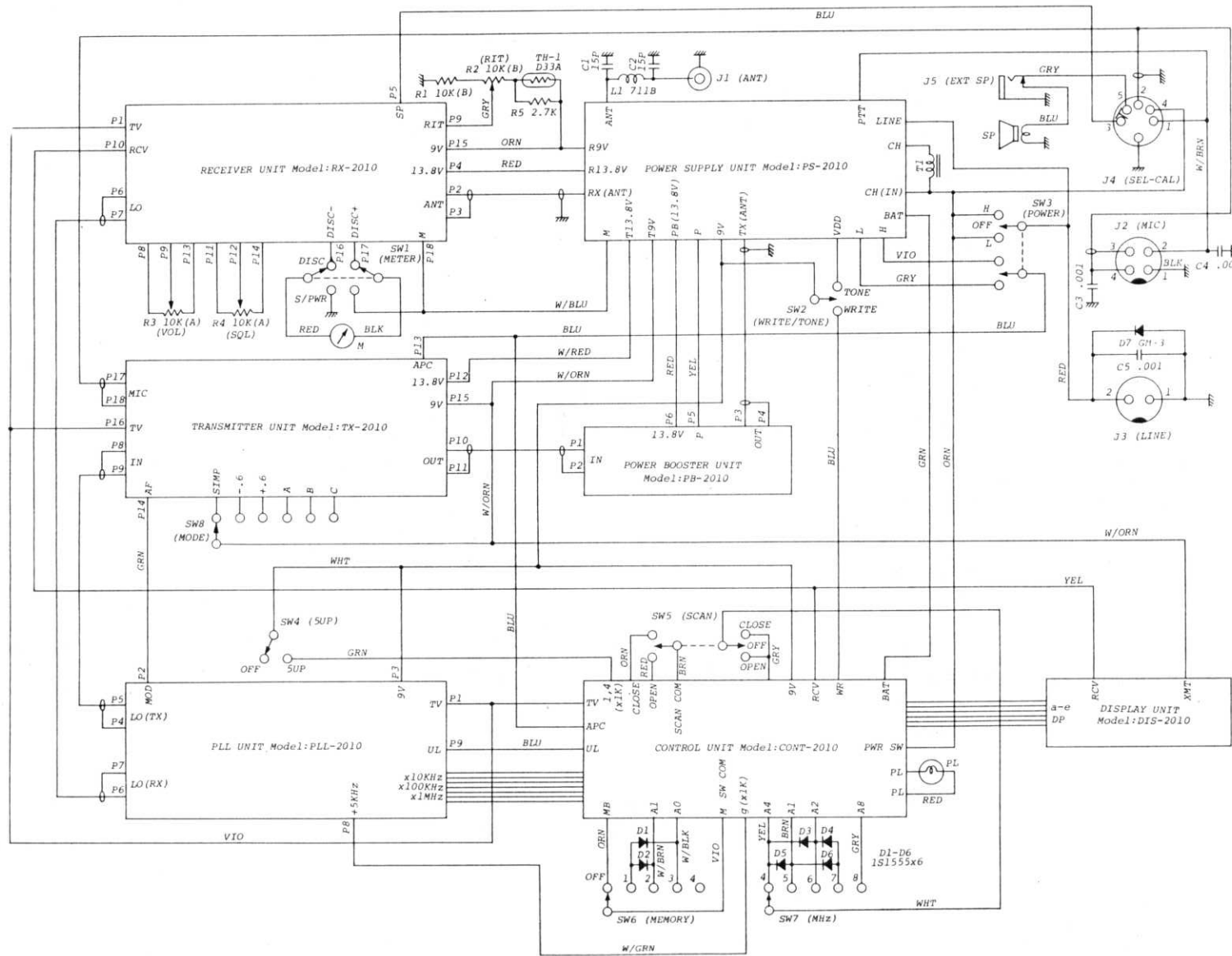

NOTE:

UNLESS OTHERWISE IN RESISTANCE IN OHMS MICRO FARADS

ALL CONNECTOR PIN NUMBER AS VIEWED FROM OUTSIDE RECEIVER

CIRCUIT AND VALUES WITHOUT ADVANCE NOTATION

Model:TX-2010 Schematic Diagram

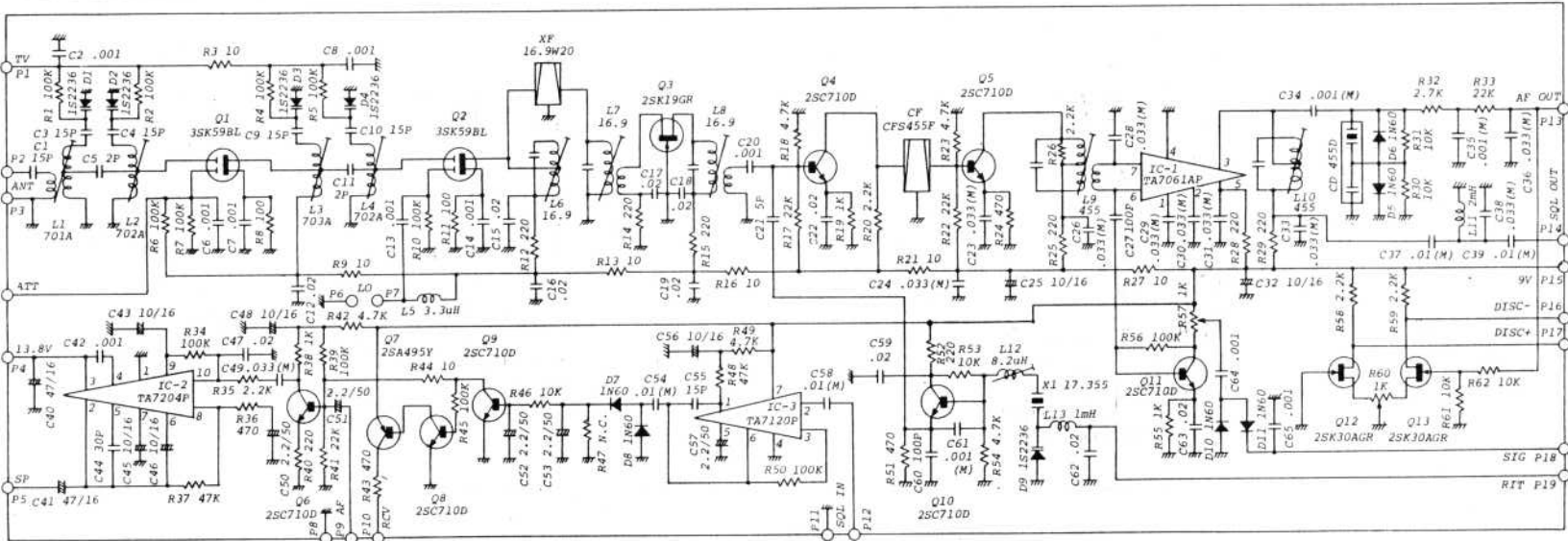

Model:TX-2010A Schematic Diagram

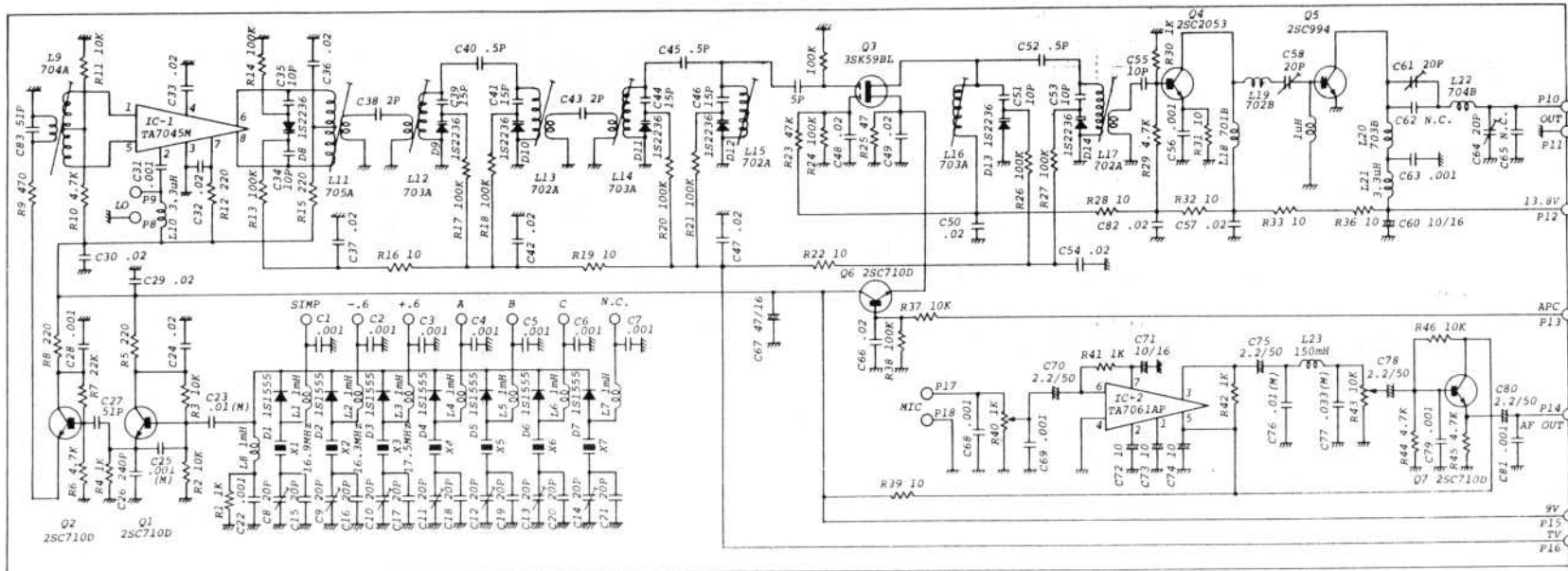

IT DIAGRAM

Model:PS-2010A,E Schematic Diagram

INDICATED VALUES ARE:
AND CAPACITANCE IN

NUMBERS ARE ASSIGNED
SIDE OF THE TRANS-

ARE SUBJECT TO CHANGE
PRICE FOR IMPROVEMENT

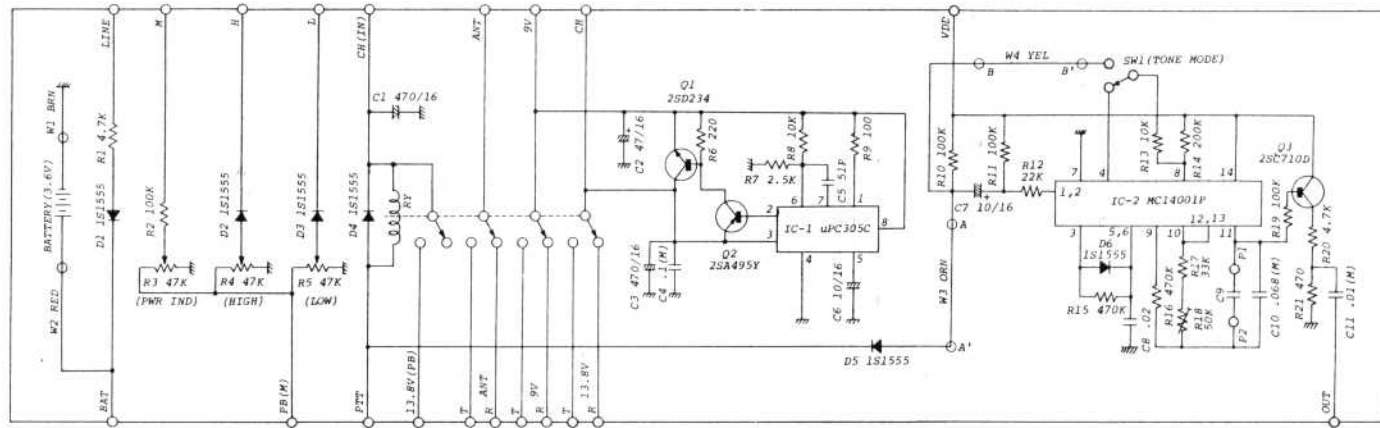

Model:CONT-2010 Schematic Diagram

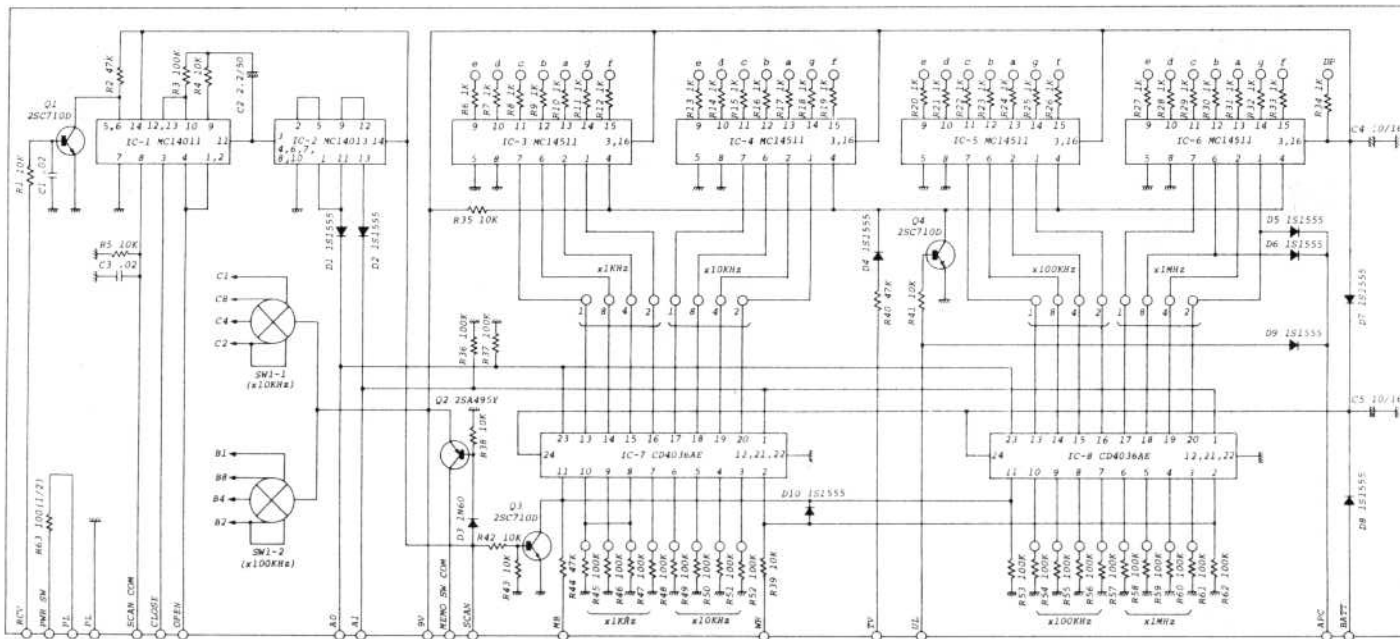

Model:PLL-2010 Schematic Diagram

P4 P5 P6 P7

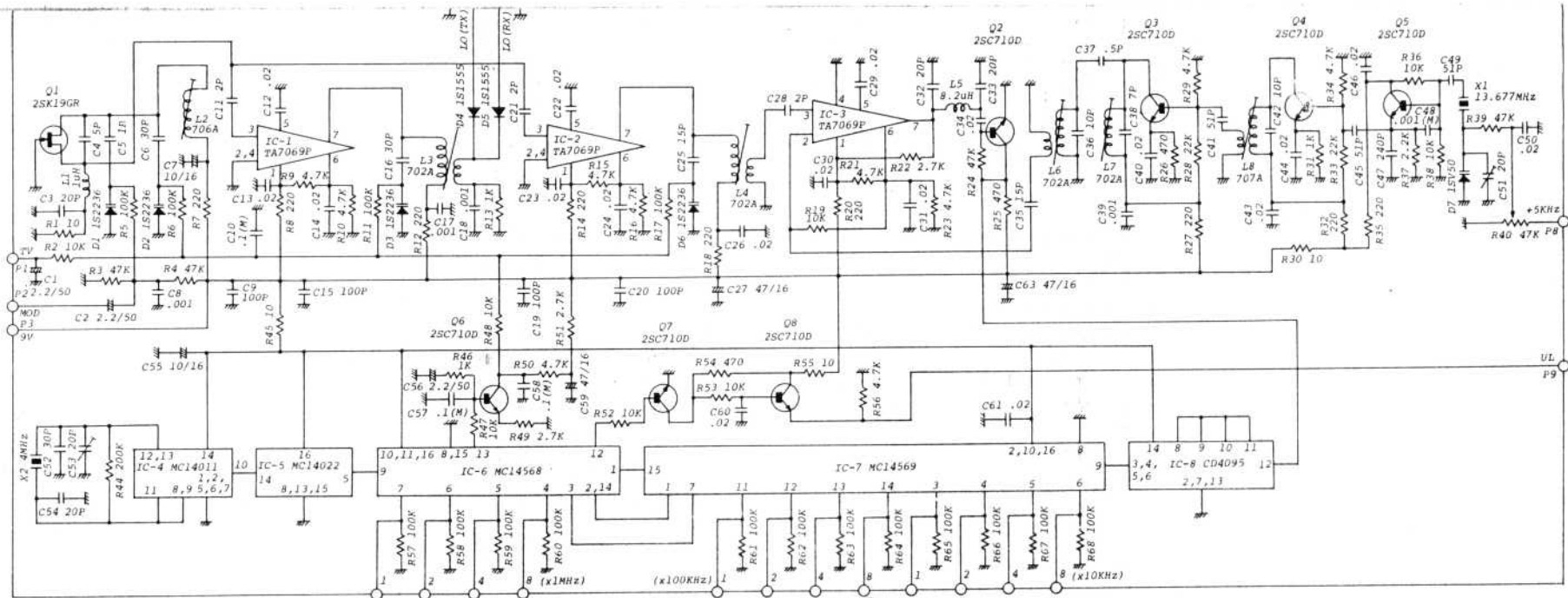

Model:DIS-2010 Schematic Diagram

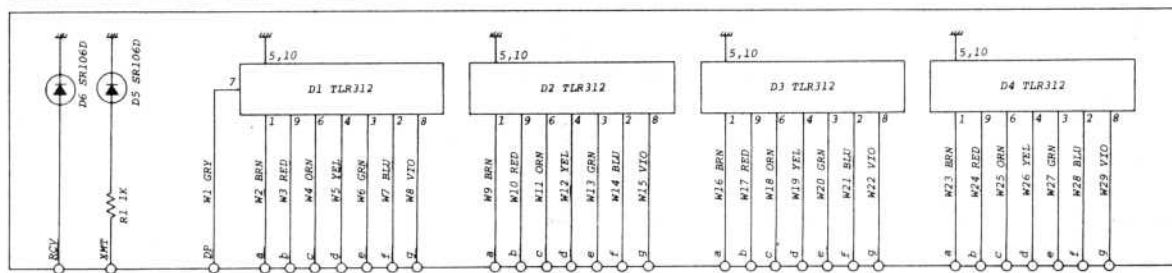

Model:PB-2010 Schematic Diagram

