

H'  
321'  
3900

**SOLID STATE 1000 CHANNEL 5KHz STEP**

**DIGITAL PHASE LOCKED SYNTHESIZER**

# **2m FM TRANSCEIVER**

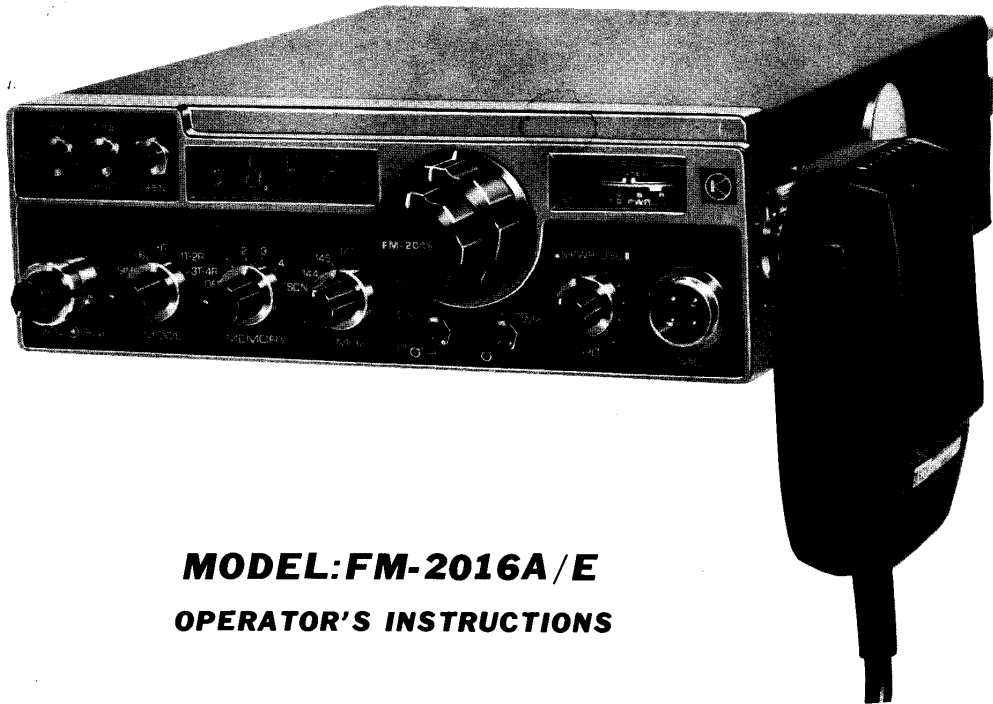

**MODEL: FM-2016A/E**  
**OPERATOR'S INSTRUCTIONS**



**KYOKUTO DENSHI CO., LTD.**

21-25, 6-CHOME, HONCHO, NAKANO-KU, TOKYO PHONE: TOKYO (382) 2681

### CAUTION--MEMORY BACK UP BATTERY

The memory back up battery has been installed at the factory. If the transceiver is to be stored without use for an extended period, remove the battery and store in a cool location to prevent possible damage to the transceiver by corrosion.

## TABLE OF CONTENTS

1.	GENERAL FEATURES .....	(1)
2.	OPERATING CONTROLS AND FUNCTIONS .....	(3)
3.	INSTALLATION AND OPERATING INSTRUCTIONS .....	(5)
4.	ADJUSTMENTS .....	(7)
5.	INTERNAL VIEWS .....	(8)
6.	BLOCK DIAGRAM .....	(9)
7.	CIRCUIT DESCRIPTION .....	(10)
8.	SPECIFICATIONS .....	(15)

# 1. GENERAL FEATURES

YOUR KDK FM-2016A, (OR E), IS A TWO METER FM TRANSCEIVER USING THE MOST UP TO DATE CMOS IC DIGITAL PLL CIRCUITRY FOR MOBILE AND BASE STATION USE. IT HAS BEEN COMPACTLY DESIGNED WITH EMPHASIS ON MAINTENANCE OF HIGH QUALITY AND YET BEING EASY TO USE AND INCLUDES THE MANY FEATURES DESCRIBED IN THE FOLLOWING.

## (A) FREQUENCY COVERAGE AND CHANNELS

144.000 - 148.995MHz, transmit and receive (FM-2016A)

144.000 - 148.995MHz, receive, 144.000 - 145.995MHz transmit (FM-2016E)

Above in 10KHz steps plus 5KHz up capability for a total of 1,000 channels. (FM-2016E - 400 channels, transmit)

## (B) DIGITAL FREQUENCY DISPLAY

Direct readout of operating frequencies using large size LED displays. Full solid state.

## (C) AIRPLANE TYPE CO-AXIAL FREQUENCY CONTROLS

Operating frequencies selected by 10KHz, 100KHz, 1MHz and 5UP switches. Most frequently used 100KHz and 10KHz switches mounted coaxially on one shaft. These switches will not go below 0 or above 9 positions to facilitate frequency changing by feel only. Permits "eyes-on-the-road" at all times for mobile operation safety and is also useful for hams with impaired sight.

## (D) ELECTRONIC MEMORY

An electronic memory using CMOS RAMs (Random access memory ICs) is provided any 4 out of the 1,000 channel capacity may be written in (stored) the memory at any time. A back up NICAD battery provided to retain memory contents while transceiver disconnected from any power source. Current drain only 25nA and internal automatic charging circuit keeps battery fully charged at all times.

## (E) TRANSMITTER OFFSET FOR REPEATOR USE

+.6 and -.6MHz positions of the mode switch provide the normal + and - 600KHz shift in the transmitter frequency. Positions 1T-2R and 3T-4R are provided for utilizing the 4 channels of electronic memory to provide 2 pairs of non-standard shifts. In these positions the operating frequency is switched between memory channels 1-2 and 3-4 automatically so that in position 1T-2R the set transmits on the frequency set up in memory channel 1 and receives on the frequency set up in memory channel 2 and likewise in the 3T-4R position. This feature provides for operating on non-standard shifts, and is also convenient when using the FM-2016 in conjunction with an up-converter, etc., for operation on 430MHz and other bands.

## (F) SCANNING

A scanning system has been included to increase the utility of the transceiver. The four memory channels are scanned in one of two possible modes as selected by the SCAN switch. In scanning for a closed channel, the scanner will stop at the first channel in use encountered, and in the open scanning mode, it will stop at the first channel encountered which is not in use. A scan-hold feature is provided to permit immediate transmission after locating a channel by scanning.

(G) RECEIVER SECTION

Dual-gate MOS-FETs are used for the RF amplifier and first mixer and provides a superior inter- and cross-modulation characteristic as well as sensitivity. These characteristics are maintained constant across the wide frequency range covered by the use of an all electronic automatic tuning circuit using varicap diodes in the RF section. The combination of a monolithic crystal in the first IF and a commercial quality 15 pole ceramic filter in the 2nd IF results in extremely sharp selectivity. The 2nd IF amplifier is built up with discrete components rather than using an IC to keep input-output coupling to a minimum. A ceramic discriminator has been adopted for improved temperature stability as well as holding alignment over a long life period. An RIT (receiver incremental tuning control) and discriminator meter is useful when contacting off-frequency stations and an RF attenuator provides approximately 10dB of attenuation when using the transceiver under extreme inter- and cross-modulation situations.

(H) TRANSMITTER SECTION

Single conversion type using a balanced mixer. 5 stages of electronic tuning similar to that of the receiver together with a 4 stage low pass filter in the transmitter output results in a clean, spur-free signal. A latest type silicon transistor is used as the final amplifier and will hold up even under the extreme conditions of an infinite VSWR load. HIGH (15 watts) and LOW (1watt) is available with the front panel power switch, and is useful for reducing power for use in conjunction with a linear. True direct frequency modulation of the VCO results in a very distortion free modulation characteristic.

(I) MULTI-PURPOSE TONE OSCILLATOR

An internal tone generator system has been provided for accessing repeaters. Two modes are selected by an internal switch (burst or continuous) and sub-audible or tone burst frequencies can be generated by changing capacitors. (FM-2016A pre-set at factory to 100Hz and FM-2016E pre-set to 1,750Hz.)

(J) ACCESSORY CONNECTOR

A 5 pin "DIN" type connector is provided on the rear panel for connection of a KDK SC-12A SEL-CALL (tone encoder/decoder) unit. Also useful for connection of phone-patch, touch-tone, remote headset-microphone combinations and similar type accessories.

(G) RECEIVER SECTION

Dual-gate MOS-FETs are used for the RF amplifier and first mixer and provides a superior inter- and cross-modulation characteristic as well as sensitivity. These characteristics are maintained constant across the wide frequency range covered by the use of an all electronic automatic tuning circuit using varicap diodes in the RF section. The combination of a monolithic crystal in the first IF and a commercial quality 15 pole ceramic filter in the 2nd IF results in extremely sharp selectivity. The 2nd IF amplifier is built up with discrete components rather than using an IC to keep input-output coupling to a minimum. A ceramic discriminator has been adopted for improved temperature stability as well as holding alignment over a long life period. An RIT (receiver incremental tuning control) and discriminator meter is useful when contacting off-frequency stations and an RF attenuator provides approximately 10dB of attenuation when using the transceiver under extreme inter- and cross-modulation situations.

(H) TRANSMITTER SECTION

Single conversion type using a balanced mixer. 5 stages of electronic tuning similar to that of the receiver together with a 4 stage low pass filter in the transmitter output results in a clean, spur-free signal. A latest type silicon transistor is used as the final amplifier and will hold up even under the extreme conditions of an infinite VSWR load. HIGH (15 watts) and LOW (1watt) is available with the front panel power switch, and is useful for reducing power for use in conjunction with a linear. True direct frequency modulation of the VCO results in a very distortion free modulation characteristic.

(I) MULTI-PURPOSE TONE OSCILLATOR

An internal tone generator system has been provided for accessing repeaters. Two modes are selected by an internal switch (burst or continuous) and sub-audible or tone burst frequencies can be generated by changing capacitors. (FM-2016A pre-set at factory to 100Hz and FM-2016E pre-set to 1,750Hz.)

(J) ACCESSORY CONNECTOR

A 5 pin "DIN" type connector is provided on the rear panel for connection of a KDK SC-12A SEL-CALL (tone encoder/decoder) unit. Also useful for connection of phone-patch, touch-tone, remote headset-microphone combinations and similar type accessories.

## 2. OPERATING CONTROLS AND FUNCTIONS

**TONE/RF ATT SWITCH** Center position OFF. Switching to WRITE position "stores" frequency set up by the MHz, 100KHz, 10KHz and SUP switches in memory channels. ATT position reduces receiver sensitivity by approximately 10dBs.

**SCAN SWITCH** Center position OFF (Hold). In CLOSE position, scanning will stop at first memory channel with an incoming signal. Sensing of channel condition utilizes squelch signal. OPEN position for locating vacant channel.

**RCV LED** Indicates when a signal is received.

**XMT LED** Indicates when transmitter is operating. LED is actuated by P/T relay.

**FREQUENCY** Display shows frequency set by the MHz, 100KHz, 10KHz and SUP switches in memory channels 1 - 4.

**POWER SWITCH** Center position OFF. Up position turns on main power to transceiver and also selects HIGH power output of 15 watts. Down position turns on main power and selects LOW power of 1 watt.

**SQUELCH/VOLUME CONTROL** Squelch control mutes receiver when no signal being received. Turning in clock-wise direction increases depth of threshold. Volume control increases volume when turned in a clock-wise direction.

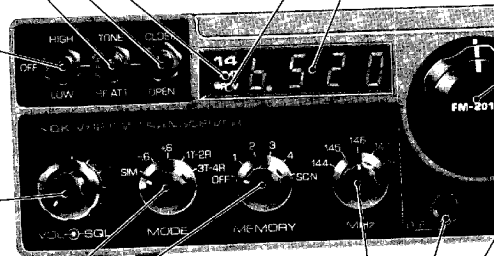

**MODE SWITCH** SIMP position for simplex (transmit and receive on same frequency) operations. +.6 and -.6 positions for standard 600KHz up and down transmitter offsets.

**NOTE: DISPLAY WILL SHOW ONLY RECEIVE FREQUENCIES IN THE +.6 AND -.6 POSITIONS.**

1T-2R and 3T-4R positions for non-standard offsets using 4 memory channels. 1T-2R uses memory channel 1 for transmit and 2 for receive frequency. Set MODE switch on SIMP for writing in frequencies in respective memory channels then switch to 1T-2R or 3T-4R position as desired.

**MHz SWITCH** Controls MHz digit of operating frequency.

**MEMORY SCAN SWITCH** OFF position puts 10KHz, 100KHz, MHz and SUP switch in control of frequency. Positions 1 through 4 select memory channels 1 through 4 and display contents of memory channel on DISPLAY LED's.

SCAN position for scanning of frequencies stored in memory channels. Frequencies will be displayed as they are scanned.

**WRITE**

write frequency controlled by

**NOTE:** switch frequency write can be QSY.

**SUP SWIT**

In  
ll  
n-  
on  
or

oper-  
r re-

RCV LED Indicates when a signal is being received. LED is actuated by squelch signal.

FREQUENCY DISPLAY 4 digits of large LED's display frequency selected by the MHz, 100KHz, 10KHz and SUP controls. Also displays frequencies written (stored) in memory channels when MEMORY switch in positions 1 - 4.

10KHz/100KHz CONTROLS Large knob controls 100KHz digit, and small knob controls 10KHz digit. Knobs will not go below 0 or above 9 to permit frequency changing by feel only for driving safety during mobile operations.

THREE-IN-ONE METER Controlled by switch mounted on RIT control. In normal RIT knob pushed in position, meter reads relative incoming signal strength for receive, and transmitter output during transmission.

When RIT knob pulled out, meter functions as discriminator meter.



MICROPHONE CONNECTOR Four pronged receptacle for connection of microphone.

WRITE SWITCH Switching to WRITE position with memory channels 1-4 will write in the frequency selected by the frequency controls in whatever memory channel selected by the MEMORY/SCAN switch.

NOTE: Operation of this switch with memory switch in OFF position will still result in the frequency set up by the panel controls to be written in to memory channel 4. This feature can be used to advantage for making a quick QSY.

SUP SWITCH Switch to control 1KHz digit. OFF for 0KHz and SUP for 5KHz.

RIT/DISC CONTROL Click-stopped at center for center frequency. Moving to + and - varies receiver frequency + and - approximately 5KHz.

Pulling knob out switches meter to give discriminator readings. Full deflection of meter + or - indicates received signal 5KHz above or below correct frequency.

ng

ANTENNA RECEPTACLE SO-239 type coaxial connector for antenna. Will accept both metric and inch threaded plugs.

SEL-CALL CONNECTOR For connection of KDK SC-10 or SC-12A, Selcall unit (tone encoder/decoder). Also useful for connection of phone-patch, touch-tone, remote microphone/headset combinations, etc.

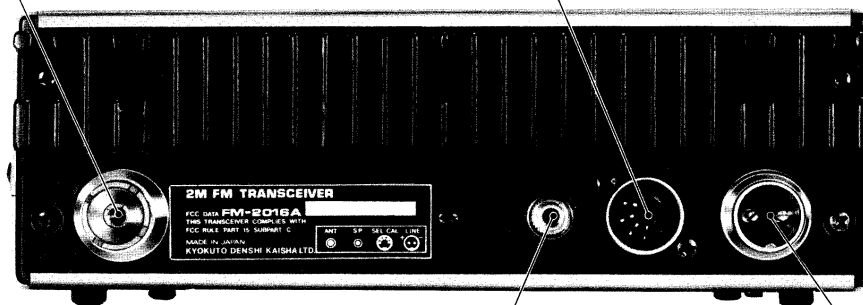

EXT SPEAKER JACK For connection of an external speaker for improved reception quality. Impedance 4-8 ohms. Miniature phone plug type plug is furnished as a standard accessory.

POWER CONNECTOR For connection of power supply using power cable furnished as standard accessory. Voltage supplied should be 13.8v dc, +10%, with negative ground. Transceiver equipped with reverse polarity protection. **IMPORTANT: USE ONLY 5A FUSES!**

### 3. INSTALLATION AND OPERATING INSTRUCTIONS

#### (A) MOBILE INSTALLATION

1. Install mobile mounting bracket furnished with transceiver to any convenient under-dash or other location using self-tapping sheet metal screws (4 x 12mm) and washers provided. 3mm holes should be pre-drilled for the 4mm self tapping screws.
2. The transceiver should be secured to the bracket using the 2 winged screws provided. The bracket is designed so the transceiver can be slid forward or backwards in the grooves as well as varying the angle.
3. Connect antenna coax to the connector on the rear panel.
4. Connect power cable to power source. Red lead (+) and black lead (-). The cable should be connected to power at a low impedance point, preferably directly to the battery terminals or the main fuse block, otherwise extraneous noises may be induced during transmission at high power.
5. Connect microphone to receptacle on lower right corner of front panel.

#### (B) HOME STATION USE

1. Small rubber feet have been provided on the transceiver to lift its bottom off the surface below and permit audio from the speaker to be heard. However, for easier access to the controls it is frequently helpful to tilt the control panel facing slightly upwards. A mobile mounting bracket used underneath the transceiver is useful for this and brackets are available optionally from your KDK dealer.
2. Connect antenna coax to the connector on the rear panel.
3. Connect power cable to a suitable supply such as a regulated power supply or battery. A good solid supply of 5A or more capacity is recommended.
4. Connect microphone to receptacle on lower right corner of front panel.

#### (C) OPERATING INSTRUCTIONS

1. PREPARATION: -- Set switches and controls as follows:

a) POWER SWITCH	LOW or HIGH as desired
b) RF ATT switch	OFF
c) SCAN mode switch	OFF
d) VOLUME control	Approximate center position
e) SQuelch control	Complete counter-clockwise position
f) MODE switch	SIMP
g) MEMORY switch	OFF
h) MHz switch	Desired frequency
i) 100KHz switch	" "
j) 10KHz switch	" "
k) SUP switch	" "
l) WRITE switch	OFF
m) RIT	Center, click-stopped position
n) S.PWR/DISC switch	S.PWR position (pushed in)

2. RECEIVING: -- During the above preparation the meter lamp will light up, the frequency display LEDs and the RCV LED will be lit up and either random receiver noises or an incoming signal will be heard from the loudspeaker.

a) If no incoming signal is heard, vary the frequency using the front panel controls and locate an incoming signal. As soon as the signal is received, the meter will deflect upwards and indicate the relative strength of the signal.

b) Squelch: -- During no-signal conditions, the random noises heard from the speaker can be annoying. Turn the Squelch control in a clock-wise direction until these noises are just extinguished. This sets the squelch threshold and only incoming signals will now be heard from the speaker. Turning the control up further may result in losing weak signals and intermittent reception of intermediate sig-

nals. Heavy squelch can be used to advantage in crowded city locations to squelch out weak interfering signals.

c) RIT and DISCriminator Meter: -- Reception may be impaired if the incoming signal is off frequency, particularly with weak signals. In such instances pull out the RIT knob to switch the meter to the DISC position and adjust RIT knob to center the needle.

d) Memory WRITE Procedure: -- This transceiver has 1,000 channels, and any 4 may be written in to the memory, such as frequently used frequencies. For example, if it is desired to store the frequency of 146.520MHz in memory channel 1 --

1. Use frequency controls and set up 146.520MHz as read out on the DISPLAY.
2. Set MEMORY switch to 1. (If nothing had been stored in this channel previously, LED display will go black at this point.)
3. Switch WRITE switch to WRITE position and then return to OFF. As soon as switch is set to WRITE position, the LED display will show 146.520MHz indicating that the frequency has been written in to the memory channel.
4. Other sequences of writing in frequencies are equally satisfactory and will not damage the transceiver.
5. NOTE: Inadvertent operation of WRITE switch even with MEMORY switch in OFF position will result in selected frequency being written in to memory channel No. 4. This feature can be used to advantage for temporary storage of frequencies, retaining the other channels for storage of repeatedly used frequencies.

e) Scanning: --

1. Set MEMORY switch to SCN position next to memory channel 4.
2. Operate SCAN switch to CLOSE or OPEN as desired. The receiver will immediately start scanning each memory channel consecutively and the DISPLAY LEDs will show the frequencies in each of the memory channels as they are scanned. If the CLOSE mode was selected, scanning will cease at the first channel found with an incoming signal. As soon as this signal disappears, scanning will resume until another signal is received. In the OPEN mode scanning will cease at the first vacant channel encountered. Use CLOSE mode for continuous monitoring of up to 4 channels, and the OPEN mode for quickly locating a vacant channel.
3. If it is desired to transmit using a channel located by scanning, return the SCAN switch to the center OFF position. Transceiver will stay on the frequency (memory channel) located by scanning until MEMORY switch is moved off the SCN position.

f) RF ATTenuator Switch: -- Switching to the RF ATT position reduces sensitivity of the receiver by approximately 10dB's. This is useful when encountering inter- or cross modulation problems due to an extremely strong signal. This is also useful for squelching out weak interfering signals as well as in plotting a radiation pattern of a directional beam antenna.

3. TRANSMITTING: --

a) Select HIGH power (15 watts) or LOW power (1 watt) as desired.

b) Depress the press-to-talk (P/T) switch on the microphone and talk into the microphone in a normal voice. Recommend that the mike be held approximately 2 inches (5 cm) from the mouth. A meter reading of approximately 8 indicates 15 watts power into a 50 ohm load. The XMT LED will light up as soon as the P/T switch is depressed indicating the transceiver is on transmit mode and will go out as soon as the switch is released indicating the transceiver has returned to the receive mode.

c) MODE switch: -- Simplex operations are conducted with the MODE switch in the SIMPLEX position (Transmit and receive on same frequency). Select +.6 or -.6 as appropriate for working repeaters with standard 600KHz offsets. If a non-standard repeater split is required, store the correct transmit and receive frequencies in the appropriate memory channels in accordance with the steps outlined in d) above and then switch the MODE switch to positions 1T-2R or 3T-4R as desired.

## 4. ADJUSTMENTS

ALL KDK TRANSCEIVERS HAVE BEEN CAREFULLY ALIGNED AND INSPECTED PRIOR TO SHIPMENT AND WE DO NOT RECOMMEND ATTEMPTING FURTHER ADJUSTMENT WITHOUT THE PROPER TOOLS AND TEST EQUIPMENT. HOWEVER, AGING OF PARTS MAY RESULT IN DRIFTING OF SOME CONTROLS PERIOD OF USE AND THE FOLLOWING DESCRIBED ADJUSTMENTS MAY BE MADE IN THE FIELD. ANY OTHER ALIGNMENT OR TUNE-UP SHOULD NOT BE ATTEMPTED WITHOUT THE PROPER TESTING EQUIPMENT AND WE RECOMMEND RETURN TO THE AUTHORIZED DEALOR OR NATIONAL DISTRIBUTOR.

a) RECEIVE "S" METER SENSITIVITY CONTROL

Adjusted to read full scale with a 20dBm input. Adjust control VR1 of Main unit in clock-wise direction to increase sensitivity.

b) DISC. METER ZERO BALANCE ADJUSTMENT

Adjust by varying control VR6 of Main Unit. Short gate terminal of Q12 to ground.

c) RIT ALIGNMENT

Set control to center click-stop position, pull out on knob and switch meter to DISC position. Apply correct frequency input to antenna receptacle and adjust L9 of Main Unit to center needle on zero. (Apply hot soldering iron tip to proximity of tuning slug of this coil to melt sealing wax on slug. CAUTION: Overheating may damage coil.)

d) MICROPHONE AMPLIFIER GAIN

Adjust using control VR7 of Main Unit. Turning in clock-wise direction increases gain. This control is best left untouched unless a severe change of gain is noted as for instance when changing to a different type microphone. Over increasing will result in constant clipping and distortion of transmitted signal.

e) TRANSMITTER DEVIATION CONTROL

Adjusted for +5KHz at factory. Turning control VR8 of main unit in a clock-wise direction will increase deviation.

f) TRANSMITTER LOW POWER

Continuously adjustable between 1 watt and maximum power using control VR5<sup>VR3</sup> of Main Unit. (Do not set below 1 watt). Clock-wise rotation increases power output.

g) TRANSMITTER HIGH POWER

Continuously adjustable between 1 watt and maximum power using control VR4 of Main Unit. Turning in clock-wise direction increases power. (Do not set below 1 watt.)

h) TRANSMITTER POWER METER

Adjusted at factory to give reading of 8 for a power output of 15 watts into 50ohm dummy load. Setting can be changed by varying control VR2 of Main Unit.

i) MULTI-PURPOSE TONE OSCILLATOR

The tone oscillator is IC-4 located on the main unit. It is designed to provide either a burst or continuous tone as selected by the internal switch. Its frequency can be set by changing capacitors and adjusting the trim-pot according to the following table:

C-124	C-125	Frequency Range	Remarks
.068mfd	.033mfd	Appx. 60 - 130Hz	FM-2016A set at 100Hz
.068 "	nil	" 90 - 210Hz	"
.0047 "	nil	" 1300 - 1800Hz	FM-2016E set at 1750Hz

# 5. INTERNAL VIEWS

TOP VIEW

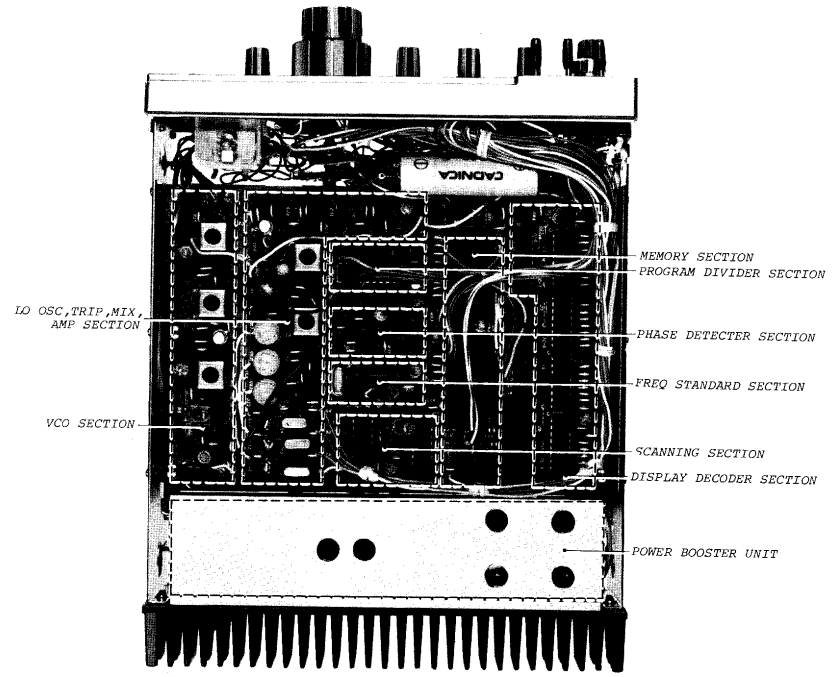

BOTTOM VIEW

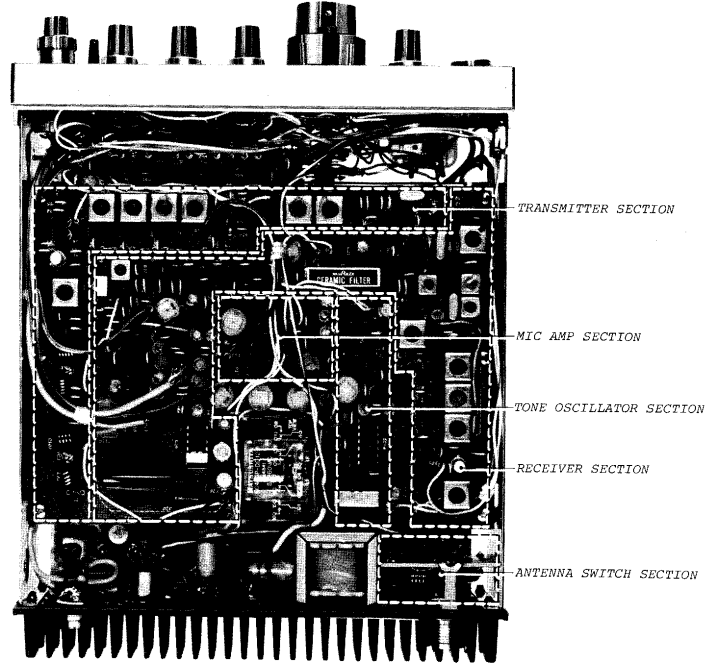

- (9) -

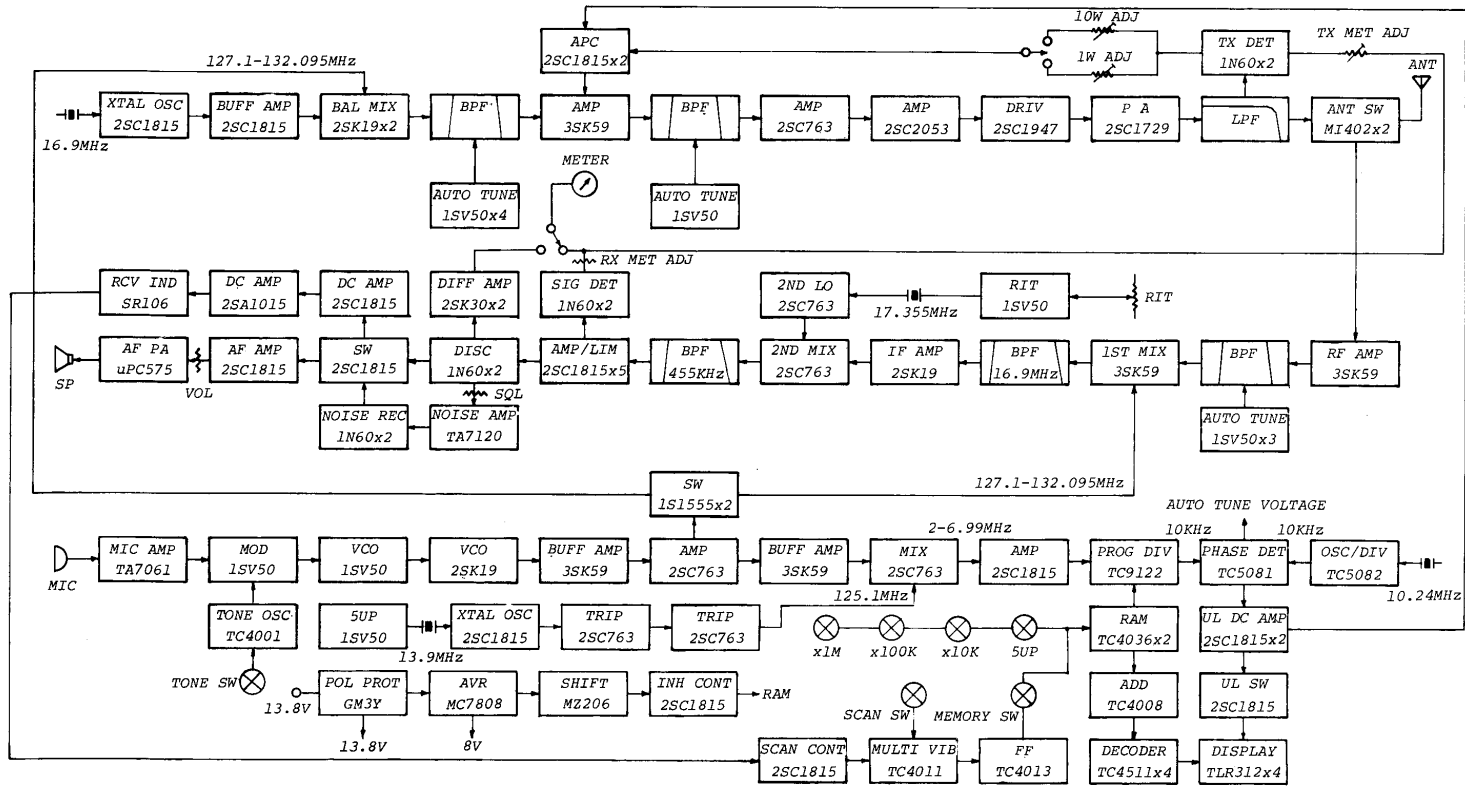

6. BLOCK DIAGRAM

## 7. CIRCUIT DESCRIPTION

PLEASE REFER TO BLOCK DIAGRAM ON PAGE 12 AND THE SCHEMATIC WHEN READING THIS SECTION.

### (A) GENERAL

The receiver first local oscillator is the VCO controlled by the PLL to provide the correct injection frequency to the mixer. The receiver is of the double conversion superheterodyne type with a 1st IF of 16.9MHz and a 2nd IF of 455KHz.

The transmitter is a single conversion type mixing the output from a 16.9MHz oscillator with the output from the VCO, with modulation being applied directly to the VCO.

### (B) MAIN UNIT

This printed circuit board contains the receiver circuits, the transmitter exciter stages, the tone oscillator, the power supply circuits and the APC circuits.

1) Receiver Circuitry: -- Input from the coax receptacle on the rear panel is fed to the input terminal of the receiver through the low pass filter and diode switching circuits on the SW PCB. This signal is amplified by Q1, a dual-gate MOS-FET. The local oscillator signal, (127.1 - 132.095MHz) is applied to gate 2 of Q2, the first mixer, with the output from the RF amplifier being applied to gate 1. The signals are mixed and results in a 16.9MHz 1st IF Signal. This signal passes through the monolithic crystal filter XF with a bandwidth of  $\pm 10\text{KHz}/3\text{dB}$ , is amplified by a JFET, Q3, and is applied to the base of the 2nd mixer, Q5. The base of Q5 is also fed the 2nd local oscillator signal of 17.355MHz which is generated by Q4. Q5 converts the 1st IF to the second IF of 455KHz. Varicap D4 is in the oscillator circuit of Q4 and a voltage controlled by the RIT control VR is applied to D4 via pin 12. The RIT control varies the oscillator frequency by approximately  $\pm 5\text{KHz}$ . The output of mixer Q5 is passed through the 15 pole ceramic filter CF which has a bandwidth of  $\pm 8\text{KHz}/6\text{dB}$ . Q6, 7, 8, 9 & 10 are the 2nd IF amplifier and limiter stages from which the signal is fed to the ceramic discriminator CD and diodes D10 and 11. Output from the discriminator passes through the de-emphasis circuit R43 and C50, the audio amplifier Q11, and is fed to the volume control via pin 19. The audio returns from the volume control via pin 25 and is then amplified by IC-1, the power amplifier. It is then outputted to the speaker via pin 16.

2) RF Attenuator: -- This circuit functions by lowering the bias voltage on gate 2 of the RF amplifier by operation of the switch via pin 5 and results in a gain reduction of approximately 10dB's. It is effective in minimizing the effects of interference from strong local signals as well as squelching out weak interference, etc.

3) "S" Meter Circuit: -- The IF signal is picked off the collector of Q7, the 2nd IF amplifier and is rectified in a voltage doubling circuit D5 and D6 and then applied to the meter to give indications of relative signal strength. VR1 adjusts meter sensitivity and normally is set for a 20dBm signal input to give a full scale reading. (Note that meter sensitivity is not linear.)

4) Squelch Circuit: -- Noise present at the discriminator is picked up through the series and parallel tuned circuits C48-L13 and C49-L14 and is then sent to the front panel squelch control through VR5 and pin 17. The signal is returned to the receiver via pin 23 and is then fed to IC-2 for noise amplification. The amplified signal is rectified in a voltage doubler circuit D12 and D13 and is then fed to the base of the squelch switching transistor Q14. During no input conditions to the receiver, receiver noises are rectified, which results in increasing the potential of Q14, connecting the emitter through to the collector. This results in shorting out the base of Q11 and thus grounding both the bias and the signal at this transistor which ceases to amplify and effectively cuts out the receiver noises from being passed to the final amplifier. As soon as an incoming signal is received and the receiver is quieted, the voltage on the base of Q14 drops, the connection between its emitter and collector is broken, normal bias is applied to the base of Q11 and

audio output from the discriminator is amplified and normal reception through the speaker takes place.

5) RCV LED Circuit: -- The base voltage of audio amplifier Q14 is amplified by two stages of direct coupled transistors, Q13 and Q12, and drives the RCV LED via pin 24. This LED provides an indication when an incoming signal is being received even if the volume control is turned completely off, or when using the transceiver in conjunction with a KDK SC-12A or SC-10 SEL-CALL unit.

6) Discriminator Meter Circuit: -- DC output from the discriminator is amplified by the differential d-c amplifier Q15 and Q16 and is applied to the RIT VR through pins 21 and 22. It then drives the discriminator meter to provide an indication of the incoming signal's frequency. VR6 is the "zero balancer" for the differential amplifier and should be adjusted so that the meter reads zero after first grounding the gate of FET, Q16.

7) Transmitter Circuitry: -- The transmitter is a single conversion, narrow band FM transmitter using direct modulation of the VCO (127.1 - 132.095MHz) which in turn is controlled by the PLL.

8) Microphone Amplifier: -- Audio from the microphone enters the transmitter through pins 8 and 9 and is then fed to the amplifier, IC-3 through the gain control, VR7. C113 and the input impedance of IC-3 combine to provide pre-emphasis. Output from the amplifier/limiter is passed through a 3KHz low pass filter, C120, L27 and C121 to remove harmonics created by clipping and is then fed to the modulator varicap in the VCO circuit via pins 10 and 11.

9) Multi-purpose Tone Oscillator: -- IC-4 and Q27 is the tone oscillator. 2 NOR gates of IC-4 make up a multivibrator. Its oscillating frequency is determined by C124, C125, R104 and VR10. (See values tabulated versus frequency in 4. i). Output from the oscillator is fed via pin 11 to a low pass filter R103, C123 to remove harmonics created by the multivibrator. This filtered output is buffered by Q27 and then fed to the low pass filter of the microphone amplifier through the level control, VR9.

The circuit can provide either a sub-audible tone or a higher frequency tone burst. It can further be switched to provide either a continuous tone for the duration of the transmission or a short burst at the beginning of each transmission by operation of the internal switch mounted on the Main Unit PCB.

The oscillator is controlled by the voltage applied by the TONE/RF ATT switch through pin 46. For the tone burst, C128, R108 and 2 NOR Gates of IC-4 make up a "one shot multivibrator" with a period of approximately .5 seconds.

The FM-2016A transceivers are set at the factory for a sub-audible tone of 100Hz and the FM-2016E transceivers are set for a 1750Hz tone burst.

10) APC Circuit (Output Control): -- RF power is sampled by the diode D2 in the power booster module and is fed to the d-c amplifier Q24 and Q25 via pin 37. The signal is then applied to the base of a buffer, Q21 and by varying the base voltage controls the output. VR3 sets the low power output and VR4 sets the high power output through the main power switch and pins 14, 15 and 27. The unlock signal from the synthesizer unit is applied to the APC through pin 27.

11) Transmitter Exciter: -- Transistor Q17 and crystal X2 combine to generate a 16.9MHz signal which is amplified by Q18 and is fed to the balanced mixer Q19 and Q20 through tuned circuits L15 and L16. The TX local oscillator signal from the synthesizer unit is also applied to the mixer through pins 6 and 7. (127.1 - 132.095MHz). The mixer converts these inputs to the desired signal frequency (144.0 - 148.995). This output is passed through 4 successive stages of electronic tuned circuits, inductors L18, L19, L20, L21 and varicaps D14, D15, D16 and D17 which are peaked at the operating frequency to minimize spurs. This circuit is similar to the circuits employed in the receiver and are effective in attenuating all but the desired frequency. The output is amplified by a dual gate MOS-FET, Q21 and passes through