

INSTRUCTIONS for No. 90801 EXCITER-TRANSMITTER

1. GENERAL

The 90801 is a modern, compact, band-switching, completely metered, general purpose, rack mounted exciter or transmitter which may be used in the amateur 3.5, 4, 7, 14, 21, 27 and 28 mc. bands. Maximum power input for CW operation is 90 watts and for amplitude modulated 'phone 67½ watts. The transmitter is carefully shielded and all leads leading from the r.f. shielded compartments are filtered and shielded to prevent r.f. leakage through external leads. The transmitter contains its own r.f. coupling arrangement

to allow proper coupling to any flat 50 to 75 ohm transmission line. The meter and switch provide a 0 to 30 ma. scale for measuring oscillator/multiplier current, a 0 to 20 ma. scale for reading amplifier screen current, a 0 to 10 ma. scale for reading amplifier grid current, a 0 to 200 ma. scale for reading amplifier plate current and a 0 to 1000 volt scale for reading amplifier plate voltage.

The 90801 consists of a 5763 oscillator or frequency multiplier and a 6146 r.f. power amplifier.

2. POWER REQUIREMENTS

A. C-W

High Voltage

400 volts d.c. at 90 to 150 ma.
to 750 volts d.c. at 90 to 120 ma.

Low Voltage

250 volts d.c. at 26 to 32 ma.
to 300 volts d.c. at 26 to 35 ma.

Heater Voltage

6.3 volts a.c. at 2 amperes.

The MILLEN 90281 High Voltage Power Supply is ideal for supplying the high voltage and the heater voltage. The MILLEN 90201 Low Voltage Power Supply is ideal for supplying the low voltage.

B. Unkeyed C-W

No low voltage power supply is required if the transmitter is never to be keyed. In this case the low voltage required for the 5763 oscillator-frequency multiplier can be taken from the high voltage supply through a built-in series resistor. The total power requirements are:

High Voltage

400 volts d.c. at 116 to 182 ma.
to 750 volts d.c. at 116 to 152 ma.

Low Voltage

None

Heater Voltage

6.3 volts a.c. at 2 amperes

The MILLEN 90281 High Voltage Power Supply can supply all power requirements for the 90801 when the Exciter-Transmitter is not keyed.

C. Amplitude Modulation and C-W

High Voltage

400 volts d.c. at 90 to 150 ma.
to 600 volts d.c. at 90 to 113 ma.

Low Voltage

250 volts d.c. at 26 to 32 ma.

Heater Voltage

6.3 volts a.c. at 2 amperes

D. Amplitude Modulation Exclusively

In this case the transmitter will not be keyed so that no low voltage power supply will be required.

High Voltage

400 volts d.c. at 116 ma. to 182 ma.
to 600 volts d.c. at 116 to 145 ma.

E. Specifications of the MILLEN 90281 High Voltage Power Supply

High voltage 500 to 750 volts d.c. at 235 ma.

Heater 6.3 volts a.c. at 5 amperes

One power supply will handle both the 90801 Transmitter and the MILLEN 90831 Modulator.

F. MILLEN 90201 Low Voltage Supply

250 volts d.c. at 115 ma.

105 volts d.c. at 35 ma. regulated

Minus 105 volts d.c. at 4 ma.

6.3 volts a.c. at 4.2 amperes

One 90201 Low Voltage Power Supply will supply the low voltage for both the 90801 Transmitter and the 90831 Modulator.

3. TERMINALS

On the rear panel of the 90801 Exciter-Transmitter are two terminal strips on which are brought out many of the d.c. points in the circuit. These many points are brought out to allow the Exciter-Transmitter to meet as many varied applications as possible. The lower terminal strip from left to right is:

GND Ground, one side of the heater voltage, positive side of protective bias, negative side of high voltage power supply and the negative side of the low voltage power supply. Since the lead connected to this terminal carries the heater current it should be a No. 18 wire or larger.

C— Grid return of the 6146 for protective bias. This terminal is normally grounded by a jumper. However, this point of the circuit is brought out so that external bias may be applied to the 6146 when the Exciter-Transmitter is excited by an external VFO which is keyed.

6.3 V. 6.3 volts a.c. at 2 amperes. This supply lead should be No. 18 wire or larger.

1. This terminal connects to an internal series resistor to supply low voltage for the 5763 oscillator-frequency multiplier from the high voltage supply when the transmitter is not keyed. Jump this terminal to plus LV terminal when no low voltage supply is used. *(EXCITER USE ONLY)*

+LV This is low voltage supply for the

5763. Connect to this terminal plus 250 to 300 volts d.c. at 18 to 20 ma.

+HV High Voltage for 6146 plate.

Upper terminal strip reading from left to right:

2. 5763 Grid Bias. This is the grid return lead of the 5763 oscillator/multiplier and is normally jumped to GND. Protective bias may be inserted at this point if desired.

3. Screen Resistor. This terminal connects to an internal series screen resistor in the 6146 circuit. This terminal should be connected to terminal 4 when the 6146 is amplitude modulated. Normally, terminal 3 will be connected to the external 'Phone-CW switch.

4. Screen of 6146. Normally this terminal is connected to the 'Phone-CW switch so that for 'phone operation terminals 3 and 4 are connected together and for CW operation the screen is supplied through a series dropping resistor from the low voltage power supply.

5. 6146 Cathode and Key. This terminal is brought out so that cathode modulation may be used. Also this allows the 5763 cathode to be keyed if desired.

6. 5763 Cathode. This terminal is normally jumped to GND but can be connected to terminal 5 for keying the entire exciter-transmitter.

GND Another ground terminal for convenience.

4. INSTALLATION

A. 5763 oscillator-frequency multiplier tube may be installed in its socket through the hole covered by the large plug button on the rear of the transmitter. To install the 6146 tube it is necessary to remove the large section of the transmitter base plate. After the 6146 has been installed in its socket the base plate should be replaced using all the screws. This shielding is essential for TVI reduction. Do not tamper with the coil spacing or the neutralization. The lead dress and the neutralization have been fixed at the factory and normally will require no change.

B. Connect a 50 to 75 ohm flat antenna transmission line to the RF output jack. If the antenna transmission line is not a low impedance flat line, connect the RF output jack to the low impedance input of the external antenna matching and loading device. If a low-pass filter is

used, it should be connected to the transmitter as near the r.f. output jack as possible.

C. 'Phone and CW Operation

GND Terminals

Connect B— of high voltage power supply, B— of low voltage power supply, and one side of the 6.3 volt a.c. heater supply. Use a No. 18 wire or larger wire.

C— Connect with a jumper to GND

6.3 V — 6.3 volt heater voltage. Use a No. 18 wire or larger wire.

1. No Connection

+LV Connect to a low voltage power supply of 250 to 300 volts d.c.

+HV Connect this terminal to the output of the modulator using a well insulated lead. This lead should be insulated for at least 1200 volts. The positive high voltage will be supplied to this lead through the modulator secondary winding or through the 'Phone-CW switch.

2. Connect this terminal to GND.
3. Connect to the 'Phone-CW switch so that this terminal will be connected to terminal 4 for 'phone operation and disconnected for CW.
4. Connect this terminal to the 'Phone-CW switch so that for 'Phone operation it will be connected to terminal 3 and for CW operation it will be connected to +250 volts through a 4700 ohm 1 watt series dropping resistor.
5. Connect to terminal 6. }
6. Connect to terminal 5. } Connect together with a jumper

When the MILLEN 90831 Modulator is used with this exciter-transmitter, terminal 3 on the transmitter should be connected to terminal 3 on the modulator and terminal 4 on the transmitter should be connected to terminal 4 on the modulator thus enabling the 'Phone-CW switch in the modulator to make the necessary changes in the transmitter screen circuit.

D. 'Phone Operation Exclusively

Terminal connections should be made as described in "C" above for 'Phone-CW operation with the following simplifications:

Terminal 3 should be jumped to terminal 4 directly

No connection is required to terminal 5

Terminal 6 should be connected to GND

In some cases it may be desirable to supply the low voltage for the 5763 from an 8500 ohm series resistor connected to the high voltage supply. CAUTION. If the key circuit should be opened when a series resistor is used, the full high voltage will be applied to the 5763 thus damaging the 5763 tube and exceeding the voltage rating of the by-pass capacitors in the 5763 circuit. Also the high voltage will appear on

the screen of the 6146 thus exceeding the voltage rating of the by-pass capacitors in the screen circuit.

E. CW Operation Exclusively.

The terminals should be connected as described in "C" above with the following simplifications:

No connection to terminal 3.

Terminal 4 connected to +250 volts through 4700 ohms 1 watt series resistor.

When the MILLEN 90201 Low Voltage Power Supply is used, the 4700 ohm resistor may be connected between terminals 6 and 8 on the power supply and terminal 8 on the power supply should be connected to terminal 4 on the Exciter/Transmitter.

F. Unkeyed Exciter.

The terminals should be connected as described in "D" above except that the +HV terminal can be connected directly to the high voltage supply.

G. Keyed External VFO.

If it is necessary to key only the external VFO, protective bias will be required for the 6146 tube. Approximately 67 1/2 volts is required to limit the 6146 plate current when excitation is removed. This bias may be obtained from external batteries or from the bias terminals in the MILLEN 90201 supply. The 5763 may use an external bias of 22 1/2 volts. However, if the low voltage does not exceed 250 volts, the 5763 plate dissipation rating is not exceeded even though no external protective bias is provided when excitation is removed. On the rear panel is a switch to convert the 5763 from an oscillator to a frequency multiplier when external VFO excitation is used. CAUTION. Do not operate the XTAL/VFO switch when voltage is applied.

H. Use of High Frequency Crystals.

The crystal oscillator in the 90801 Exciter-Transmitter is designed to use the modern rather delicate overtone crystals as well as standard 4 and 7 mc. crystals. C2 is a small trimmer condenser used to adjust overtone crystals for maximum output. C2 is available through the plug button on the bottom plate of the transmitter.

5. TUNING

1. Set TUNE/TRANS switch to TUNE.
2. Set XTAL/VFO switch on rear panel for desired operation.
3. Plug in crystal or VFO.
4. Set meter switch to G. In this position the meter reads grid current and full scale deflection is 10 ma.
5. Set the OSC/BUF switch to desired transmitter output frequency.
6. Set the OSC/BUF tuning condenser to the approximate calibration on the panel.
7. Set the AMPLIFIER tuning condenser to the approximate calibration.
8. Set the amplifier output bandswitch to the desired frequency band.
9. Set the coupling condenser exactly at minimum coupling. This also corresponds to minimum capacity in the antenna loading circuit.
10. Apply heater voltage.
11. Connect the RF load to the RF output connector on the rear of the transmitter.
12. After the heaters have been allowed to warm, apply reduced high voltage. When the MILLEN 90281 High Voltage Power Supply is used, set the HIGH-LOW switch on the rear of the power supply to low and set the HIGH-LOW slider to low before applying power.
13. Apply low voltage.
14. Tune the OSC/BUF condenser for maximum grid current and then reduce the grid current to 3 ma. by detuning. Leaving the oscillator frequency-multiplier detuned will cause no harm, however, grid current to 6146 in excess of 3 ma. will cause excessive screen current, reduced output, and will cause the maximum output to occur at a tuning point different from the minimum plate current tuning point. Therefore, the grid current should always be reduced to 3 ma. by detuning the 5763 or reducing input from VFO.
15. Change the meter switch to "P". In this position the meter reads 6146 plate current. With the TUNE/TRANS switch in the TUNE position this current reading should be quite low.
16. Tune the AMPLIFIER slowly, watching the meter for a sharp dip.
17. Switch the TUNE/TRANS switch to TRANS.
18. Tune the AMPLIFIER condenser for a minimum plate current.
19. Turn the COUPLING control slightly clockwise, thus increasing the plate current to some point between 20 and 120 ma.
20. Tune the AMPLIFIER for minimum plate current. Repeat 18 and 19 until the plate current is the desired loaded current. For CW operation this current may be any value from 100 to 150 ma. However, at the higher voltage the plate current in amperes times the plate voltage as indicated when the switch is in the VM position should not exceed 90 watts. For 'phone operation the loaded plate current should be set very close to 113 ma.
21. Remove high and low voltages.
22. Increase plate voltage to the desired operating voltage.
23. Apply power.
24. Readjust coupling to the desired plate current.
25. Set meter switch to S. G. In this position the meter reads the screen grid current of the 6146 and the full scale meter deflection is 20 ma. The screen current should not exceed 15 ma. In normal operation the screen current will not exceed 12 ma. and will often run between 8 and 11 ma. The screen current is the most sensitive indication in the entire transmitter as a change in screen current results from a change in grid excitation or heating of the 6146 plate or any other change which indicates improper operation.
26. Set the switch to G and readjust the OSC/BUF to 3 ma. grid current as in "14" above. The transmitter is now completely tuned and should operate satisfactorily. This tuning procedure is considerably more difficult to describe than to perform. It will be noted that this transmitter is particularly easy to tune and load.

6. CALIBRATION

The 90801 Exciter/Transmitter has approximate calibrations on the panel to aid in the initial setting of the controls thus avoiding tuning to an unwanted frequency multiple.

However, the rough calibrations on the panel are in no way intended as an indication of final tuning.

7. NEUTRALIZATION

As in any high gain beam tetrode tube, the 6146 has a tendency to self oscillate at high frequencies. This tendency towards self oscillation has been eliminated completely in the 90801 by means of link neutralization. The neutralizing adjustment is the placement of the neutralizing link coil in the 5763 plate coil. This adjustment is very carefully made at the factory and in all probability will never require readjustment.

Should definite signs of oscillation develop for any reason, the transmitter can be reneutralized by bending the link coil on the inside of the 5763 plate coil. The point at which complete neutralization over the 14, 21, 27 and 28 mc. bands occurs is quite sharp and careful adjustment is required to get complete neutralization. Indications of complete neutralization are the same in this transmitter as in any other.

8. COUPLING

The RF output coupling system in this transmitter is a series tuned inductively coupled low impedance arrangement. On most bands, optimum coupling occurs very near minimum capacity of the coupling capacitor, therefore, it is essential that the coupling capacity be set exactly to MIN before attempting to load. Use

care to use no more coupling capacity than is required to result in the desired loaded plate current. At 3.5 mc. it will be necessary to use nearly all of the coupling capacity. However, on other bands use of too much coupling capacity will result only in decreased efficiency and broad tuning.

9. AMPLITUDE MODULATION

The 6146 beam tetrode in the 90801 should have modulated voltage applied to the screen grid as well as to the plate to assure linear 100 percent modulation. Modulated voltage can be applied to the screen by supplying the screen from the modulated high voltage through the internal series dropping resistors, R12 and R13. The end of this series resistor is connected to terminal 3, thus terminals 3 and 4 should be jumped together by the external 'Phone-CW switch for 'phone operation. The maximum tube ratings with amplitude modulation are 600 volts d.c. at 113 ma. Under these conditions the screen current is approximately 12 ma. so that the r.f. load impedance presented to the modulator is 600 volts divided by 125 ma or 4800 ohms. In loading the transmitter for 'phone operation, the transmitter should be loaded as nearly as possible to 113 ma plate current so that proper impedance matching is assured and so that the tube ratings are not exceeded. The grid excitation required is approximately 3 ma.

The performance of the modulated transmitter can best be checked on a cathode ray oscilloscope such as the MILLEN 90900 series of oscilloscopes. The vertical deflection plates of the oscilloscope should be supplied with r.f. voltage obtained by coupling loosely to the transmitter output. The most satisfactory coupling arrangement is a tuned circuit which

is loosely link coupled to the amplifier output. The horizontal plates of the oscilloscope should be supplied with audio voltage from a voltage divider across the output of the modulator. This will give the familiar trapezoidal pattern fully described in the ARRL Handbook.

The MILLEN 90831 Modulator was especially designed for use with the 90801 Transmitter. This modulator has sufficient output for 100 percent modulation of the transmitter at maximum tube ratings. It also contains an output voltage divider for ease in oscilloscope monitoring and a 'Phone-CW switch which makes the complete changeover from 'phone operation to CW operation for the transmitter and modulator. The 90831 Modulator was designed such that one MILLEN 90281 High Voltage Power Supply is all that is required to supply the high voltage for both the modulator and the transmitter, and a single MILLEN 90201 Low Power Voltage Power Supply can supply low voltage to the modulator speech amplifier stages, modulator screen, and transmitter low voltage. Thus, a complete 67 watt 'phone transmitter consists of one 90801 RF Transmitter, one 90831 Modulator, one 90281 High Voltage Power Supply and one 90201 Low Voltage Power Supply. The 90902 2 inch rack mounted oscilloscope is recommended as the ideal 'phone monitor.

10. TVI

The 90801 Exciter/Transmitter has been designed carefully to minimize television interference. The r.f. sections of the transmitter are carefully shielded so that minimum leakage occurs. All leads from the r.f. sections to the switch, terminal, and metering sections are shielded and carefully by-passed, thus no r.f. should be carried out of the transmitter on the external leads. The 6146 output tube is always operated as an amplifier, thus the output stage of the 90801 is not in itself a harmonic generator and there are two high Q tuned circuits and a buffer amplifier between any harmonic generated and the transmitter output. In

some installations it may still be necessary to use a low pass or band-pass TVI filter in the output lead and in cases of interference to very close television receivers a high pass filter in the input to the receiver may be required merely to prevent overloading.

Should TVI be a problem, be certain that the difficulty is not arising from the external VFO. The use of the 90801 TVI treated transmitter, a simple low pass output filter, and a high pass receiver input filter should cure even the most difficult problem of TVI. In normal installations no precautions other than the use of the 90801 will be required.

11. PRECAUTIONS

A. Never apply screen voltage to the 6146 before plate voltage is applied to the 6146. Screen current will be excessive when the plate is too lightly loaded. Immediate and permanent damage to the tube results from excessive screen current.

B. Do not apply excessive screen voltage to the 6146. This will result in excessive screen current which will damage the tube.

C. Do not block the free flow of air through the transmitter. The 90801 is designed for

rack mounting which will allow access of air to the bottom of the transmitter. Do not cover the air openings on either side of the transmitter.

D. Do not lift the key when the 5763 is supplied by a series resistor from the high voltage or when the 6146 screen is supplied by its series resistor from the high voltage.

E. Do not leave high voltage on 6146 when the transmitter is loaded too lightly. Load quickly to avoid overheating coupling coils.

12. TECHNICAL SUMMARY

Power Supply

High Voltage

400 volts d.c. at 90 ma. to 182 ma.
to 750 volts d.c. at 90 ma. to 152 ma.

Low Voltage

250 volts d.c. at 26 ma. to 32 ma.
to 300 volts d.c. at 26 ma. to 35 ma.

Heater Voltage

6.3 volts a.c. at 2 amperes

Power Input

C-W — 90 watts maximum
A-M — 67 1/2 maximum

Physical Dimensions

Height—3 1/2 inches

Width—19 inches

Depth—6 1/4 inches

Weight—10 pounds

The 90801 Exciter/Transmitter is designed to mount in a standard rack.

Tube Complement

Oscillator/frequency multiplier — 5763
R-F Power Amplifier — 6146

Frequency Range

3.5, 4, 7, 14, 21, 27, and 28 mc. amateur bands.

ALL DIMENSIONS UNLESS OTHERWISE NOTED MUST BE HELD TO A TOLERANCE OF

OUTLINE DIMENSIONS

FIRST MADE FOR 50 WATT EXCITER

DESIGNED BY

DRAWN BY J. HEFFERNAN

JAMES MILLER MFG. CO., INC.

WALDEN, MASS., U.S.A.

CHECKED BY P.A.C.

APPRO

Copyrighted by J. M. Co., Inc., 1954

K90801

DATE

11-13-53

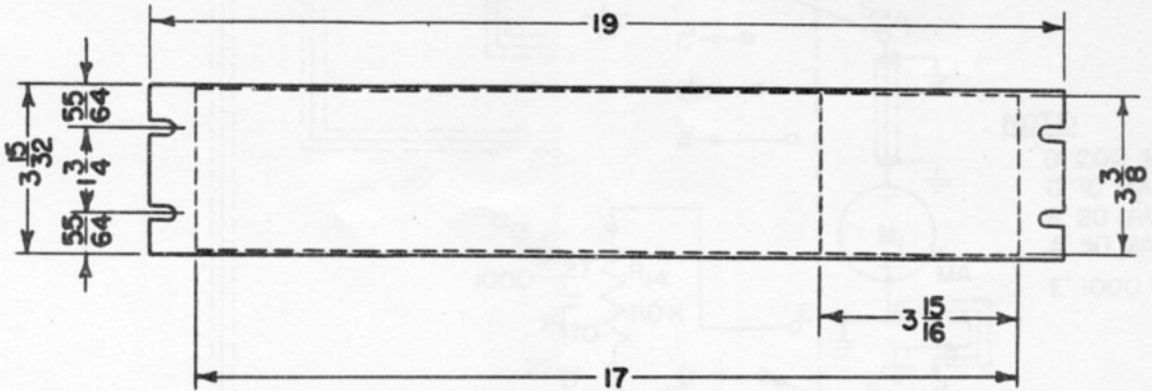
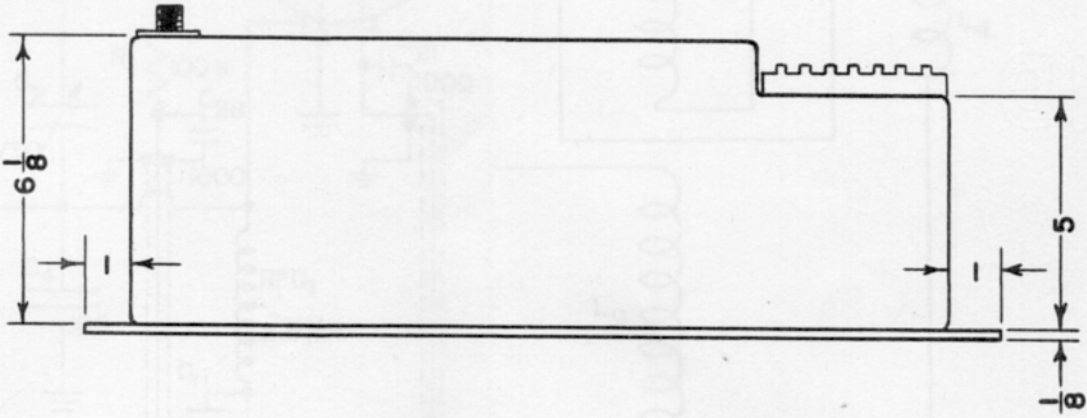

ALL DIMENSIONS UNLESS OTHERWISE NOTED MUST BE HELD TO A TOLERANCE OF

OUTLINE DIMENSIONS

FIRST MADE FOR 50 WATT EXCITER

DESIGNED BY _____
DRAWN BY J. HEFFERNAN

CHECKED BY P.A.C.
APPROVED _____

JAMES MILLEN MFG. CO., INC.
MALDEN, MASS., U.S.A.

K 90801

DATE
11-13-53

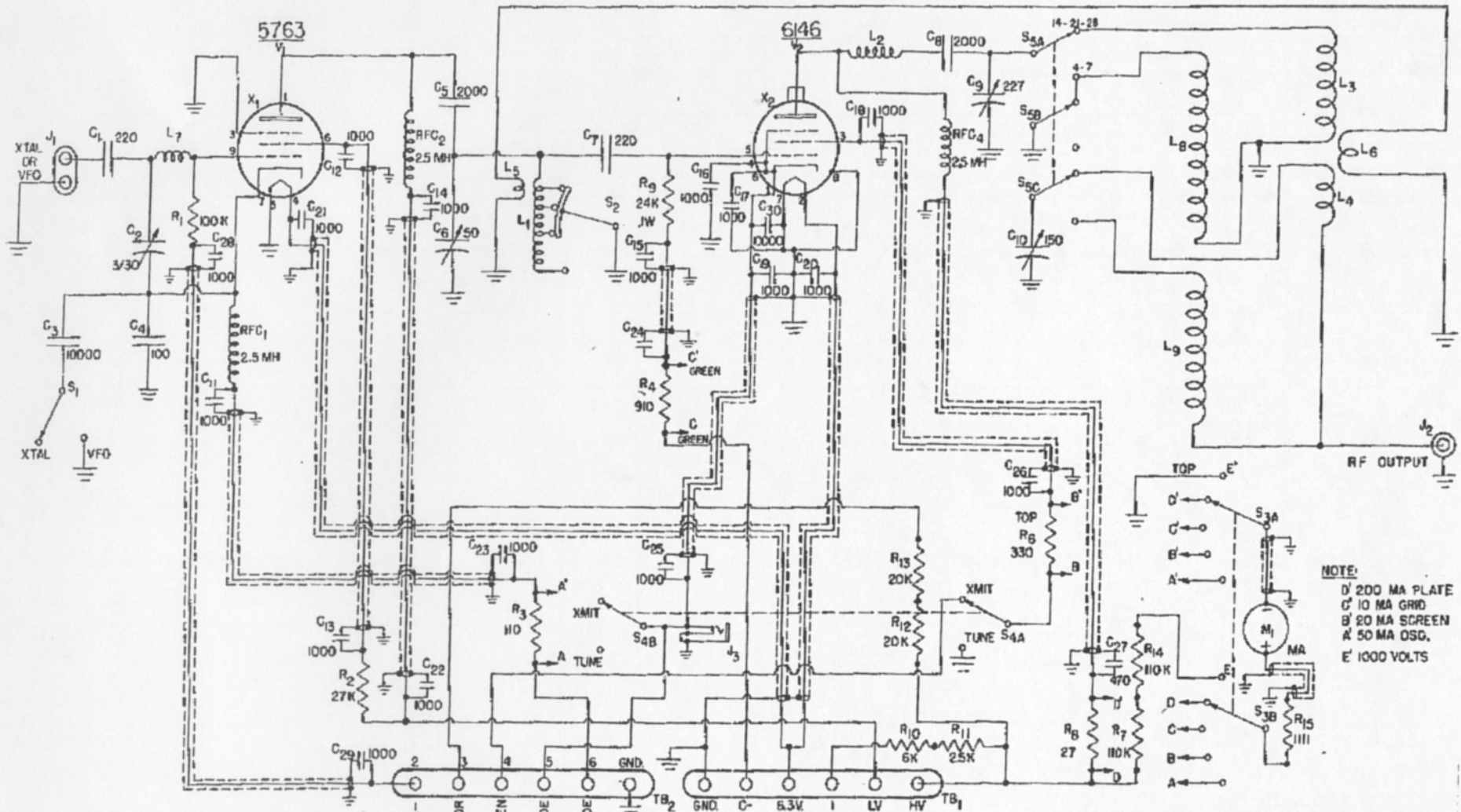

NOTE:
ALL CAPACITIES IN MMF
SWITCHES SET FOR 21-28 MC.

.9
.15
C-30
RFC-4

REV. 8 AND 9 APPLY TO
SER. NOS. 43 AND ABOVE

NOTE:
D' 200 MA PLATE
C' 10 MA GRID
B' 20 MA SCREEN
A' 50 MA OSD.
E' 1000 VOLTS

ALL DIMENSIONS UNLESS OTHERWISE NOTED MUST BE HELD TO A TOLERANCE OF

90801 TRANSMITTER/EXCITER

FIRST MADE FOR STOCK

DESIGNED BY RWC

CHECKED BY RWC

DRAWN BY AJE

APPROVED

JAMES MILLEN MFG. CO., INC.
MALDEN, MASS., U.S.A.

M 90801

DATE
7-24-53

94-54	9	REDRAWN - ADDED C ₃₀	V.O.G.
-------	---	---------------------------------	--------