

INSTRUCTION MANUAL
for
THE
NATIONAL MODEL
HRO-60

RADIO RECEIVING
EQUIPMENT

An Outstanding Communications Receiver
of proven integrity and performance in
Commercial and Amateur stations.



PRICE \$1.00

National

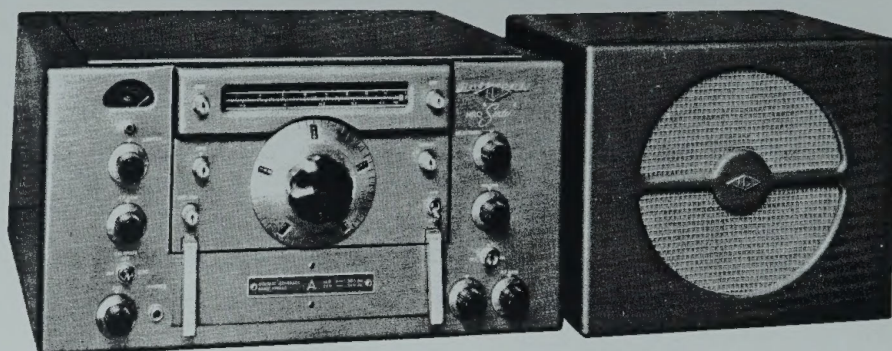

HRO-60 Receiver

FEATURES . . .

- Tuning Range 50-430 Kcs., 480-35,000 Kcs., and 50,000-54,000 Kcs.
- Direct Frequency Reading Slide-Rule Dial
- Thirteen Tuning Bands Accurately Calibrated
- Calibrated Bandsread for 6, 10-11, 15, 20, 40 and 80 meter Amateur Bands
- Double Conversion for image rejection up to 90 db. at 30 Mc.
- High Sensitivity — Exceptional Stability
- Excellent Signal to Noise Ratio
- Flexible Crystal Filter with Six Positions of Selectivity
- Automatic, Adjustable Threshold, Double Action Noise Limiter
- High-Fidelity, Push-Pull Audio Amplifier
- Provisions for mounting N.B.F.M. Adaptor and Crystal Calibrator Units within Receiver
- Temperature Compensation
- Plug-In Coils for Efficiency and Flexibility
- Built-In Power Supply

National Company, Inc.

THE HRO-60 RADIO RECEIVER

SECTION 1. DESCRIPTION

1-1. GENERAL

The HRO-60 is a deluxe radio receiver featuring performance and versatility. It uses eighteen tubes including a rectifier, a voltage regulator and a current regulator tube. It consists of a highly selective superheterodyne circuit for the reception of code and phone signals throughout the frequency ranges of 50 to 430 and 480 to 7000 kilocycles. When receiving phone or code signals in the range of 7,000 to 35,000 and 50,000 to 54,000 kilocycles the receiver is automatically switched to a double conversion superheterodyne circuit resulting in excellent image rejection. The HRO type receivers have long been outstanding and proven performers in Communication and Amateur services. This new series of HRO-60 receivers maintains all the desirable features of the previous models plus many desirable innovations emanating from the latest advances in receiver circuitry and mechanical design. It is housed in a cabinet styled in an attractive gray finish with a self-contained power supply adequately isolated from the R.F. circuits. A calibrated, illuminated slide-rule dial provides direct reading in megacycles for each of the General Coverage coil sets as well as an additional bandspread scale for those coil sets incorporating this feature. A front-panel mounted oscillator trimmer control is provided to assure precise calibration. Of course, the dial-driving mechanism features the micrometer dial. Stable operation and freedom from drift are achieved by means of ceramic insulation in the coil sets and brush boards, temperature compensation, voltage regulation and current regulation of the oscillator and mixer circuits. A single front-panel mounted control switch selects any one of the four modes of operation, C.W., Phone, Narrow-Band F.M. or Phono. Sockets are mounted on the receiver chassis to accommodate the National Type NFM-83-50 FM adaptor and the National Type XCU-50-2 Crystal Calibrator Unit. These accessories may be permanently installed and switched On and Off by means of the front-panel switches. At the rear of the receiver, sockets are available for external use of the National Type SOJ-3 Select-O-Ject and National Type 650S vibrator Power Supply or battery power supply. A push-pull audio system delivers the utmost in audio frequency response and undistorted power output from the built-in output transformer. Other highlights include a six-position crystal filter, maximum bandspreading of the amateur bands, a quick-acting bandspread switch and a dimmer control for the slide-rule dial and S-meter lamps.

A standard equipment consists of a receiver, loudspeaker and coil sets A, B, C and D. Coil sets E, F, G, H, J, AA, AB, AC and AD may be obtained as desired. Accessories available include the National types NFM-83-50 Narrow-Band F.M. adaptor, XCU-50-2 Crystal Calibrator, SOJ-3 Select-O-Ject and 650S Vibrator Power Supply.

1-2. CIRCUIT

For all but the frequency ranges above 7 megacycles the circuit utilizes two tuned stages of radio frequency amplification, a tuned mixer stage, a high-frequency oscillator employing a tube separate from the mixer tube, a first intermediate frequency amplifier stage employing a variable-selectivity crystal filter and two additional I.F. amplifier stages all operating at 455 kilocycles, a combined second detector-automatic volume control stage, an S-Meter amplifier, a double-action adjustable threshold double-diode noise limiter, a first audio amplifier, a phase inverter, a push-pull audio amplifier and a beat frequency oscillator coupled to the second detector to provide for C.W. reception.

When any of the coil sets covering a frequency range above 7 megacycles are plugged in, the automatic conversion switch connects a second conversion stage ahead of the 455-kilocycle I.F. amplifier. This consists of a single tube functioning as a combined mixer-oscillator. A frequency of 1990 kilocycles ± 3 kilocycles is used as the first conversion frequency.

All voltages required by the receiver are supplied by a built-in power supply. A voltage regulator tube is used to regulate the plate supply to the high-frequency oscillator and the S-Meter amplifier stages. In addition, a current regulator tube is used to stabilize the filament voltage of the high frequency oscillator and the mixer.

1-3. ANTENNA INPUT

Antenna input terminals are provided at the rear of the receiver. The input circuit is suitable for operation

with a single-wire antenna, a balanced feed line or a low impedance 72-ohm unbalanced concentric transmission cable. The actual antenna input impedance is between 300 and 600 ohms depending on the frequency of the input signal.

1-4. TUBE COMPLEMENT

The HRO-60 receiver is supplied complete with tubes which are tested in the receiver at the time of alignment.

The tubes employed are as follows:

First R.F. Amplifier	6BA6
Second R.F. Amplifier	6BA6
Mixer	6BE6
High-Frequency Oscillator	6C4
Second High-Frequency Converter	6BE6
First I.F. Amplifier	6SG7
Second I.F. Amplifier	6SG7
Third I.F. Amplifier	6SG7
Second Detector - A.V.C.	6H6
Noise Limiter	6H6
S-Meter Amplifier - Phase Inverter	6SN7GT
First A.F. Amplifier	6SJ7
Audio Output (2)	6V6GT
Beat Frequency Oscillator	6SJ7
Voltage Regulator	OB2
Current Regulator	4H-4C
Rectifier	5V4G

1-5. TUNING SYSTEM

The frequency range of the HRO-60 is covered in thirteen bands as follows:

<u>COIL SET</u>	<u>GENERAL COVERAGE</u>	<u>BANDSPREAD</u>
A	14.0 - 30.0 Mc.	27.0 - 30.0 Mc.
B	7.0 - 14.4 Mc.	14.0 - 14.4 Mc.
C	3.5 - 7.3 Mc.	7.0 - 7.3 Mc.
D	1.7 - 4.0 Mc.	3.5 - 4.0 Mc.
E	900 - 2050 Kc.	
F	480 - 960 Kc.	
G	180 - 430 Kc.	
H	100 - 200 Kc.	
J	50 - 100 Kc.	
AA		27.0 - 30 Mc.
AB	25 - 35 Mc.	
AC		21.0 - 21.5 Mc.
AD		50 - 54 Mc.

As shown above, plug-in coil set types AA, AC, AD, A, B, C and D provide bandspread coverage of the 6, 10-11, 15, 20, 40 and 80 meter amateur bands. The AA, AC, AD, B, C and D bands are spread out so as to cover 400 dial divisions while the A band is spread 430 divisions on the 500-division main tuning dial. This is accomplished by switching a small variable capacitor in series with each section of the main tuning capacitor, thus reducing its effective capacity range. All of the coil sets are factory aligned in the receiver using accurate crystal-controlled test oscillators thus assuring precise alignment.

The micrometer type dial drives the main tuning capacitor through a worm drive having a reduction ratio of approximately 20 to 1. Backlash is eliminated by the use of a spring-loaded split worm wheel which assures positive drive in either direction at all times. This dial has an effective scale length of approximately twelve feet and

is calibrated from zero to 500.

A slide-rule type dial is synchronized with the micrometer dial by means of an anti-backlash gear and an efficient string drive arrangement. A dial drum provides a means of mounting eight scales. Each of these scales is calibrated in megacycles for the general coverage and/or bandspread frequencies depending on the coil set. Mounted on the front panel is a band selector control for ease in rotating the dial drum to select the proper band scale to correspond to the coil set in use. Each scale is clearly marked with the band designation. Two pilot lamps are used, one at each end of the dial scale drum, for illumination. The degree of illumination is controlled by the front-panel mounted dimmer control.

1-6. CRYSTAL FILTER

The selectivity characteristics of the HRO-60 are made adjustable by means of a crystal filter. Located in the first intermediate frequency amplifier this crystal filter is designed for extreme flexibility and efficiency of operation. A six-position Selectivity switch and a crystal Phasing control are front-panel mounted for adjustment of the filter. Figure Number 1 shows the selectivity characteristics of the receiver for each of the six degrees of selectivity.

The crystal filter may be used for either C.W. or phone reception; any degree of selectivity from true single-signal to A.M. broadcast reception being available. Operation of the Phasing control provides for efficient suppression of interfering C.W. signals or M.C.W. signals which may produce objectionable heterodynes.

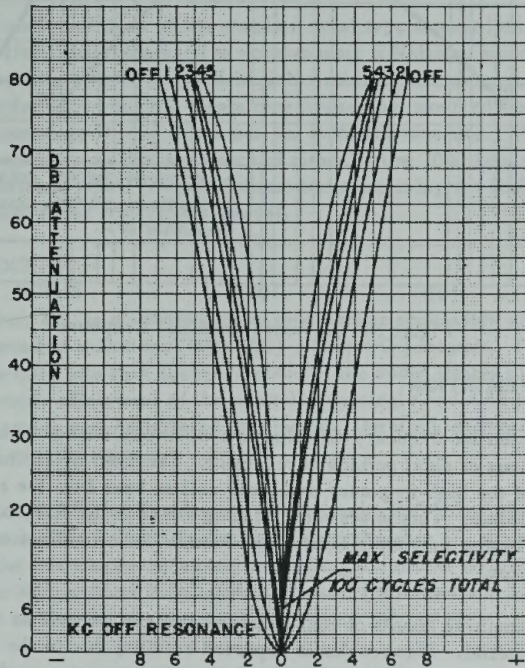

Figure No. 1. Crystal Filter Selectivity Curves

1-7. NOISE LIMITER

The noise limiter in the HRO-60 receiver uses an automatic type double-action circuit resulting in the limiting of noise pulses on both the positive and negative peaks. It is equally effective on both C.W. and phone recep-

tion. The usefulness of this limiter will be most appreciated on the higher frequency bands of the receiver where automobile ignition noise and other high frequency disturbances are effectively suppressed. A threshold control on the front panel permits adjustment of the level at which limiting action starts.

1-8. TONE CONTROL

The Tone control circuit has been especially designed to allow variation of audio response to suit reception requirements. In the extreme counterclockwise position with the switch Off maximum low frequency attenuation occurs to afford improved intelligibility when using the crystal filter with sharp selectivity. When rotated clockwise until the switch is just turned On the control provides a comparatively flat response over the entire usable audio range. Further clockwise rotation will result in the high audio frequencies being attenuated. If a signal is weak and partially obscured by background noise or static, an improvement in readability will be obtained by rotating the Tone control in a clockwise direction thereby attenuating the higher audio frequencies.

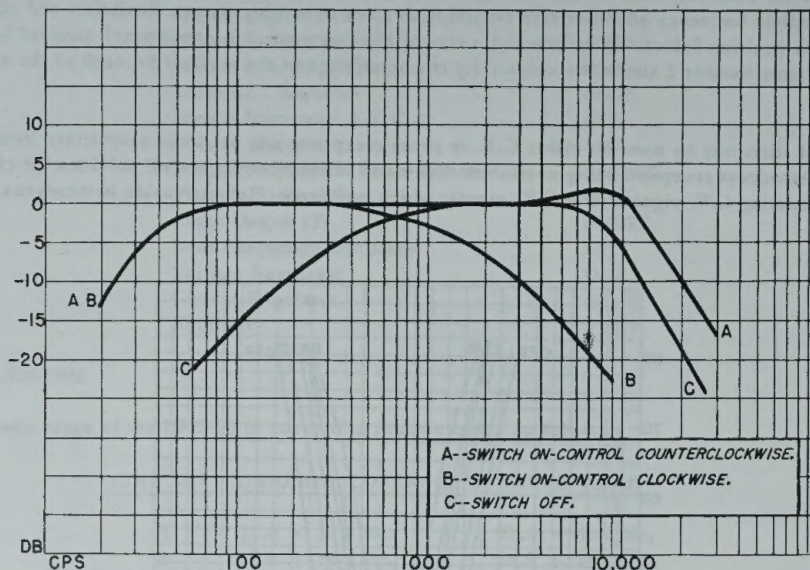

Figure No. 2. Audio Amplifier Response

1-9. TEMPERATURE COMPENSATION

The HRO-60 is compensated for frequency drift due to temperature changes which may detune the receiver from the desired signal over long or short periods of reception. The most objectionable cause of frequency drift is the change of inductance of the high-frequency oscillator coil as heat from the tubes causes the interior of the receiver to increase in temperature. This undesirable heating effect in the R.F. coils is minimized by the position of the plug-in coil sets in that they are placed at the bottom of the receiver underneath the chassis in a separately shielded compartment.

The coil set terminal connecting boards of each shielded coil can as well as their mating brush blocks have been made of ceramic type material. This results in improved stability due to the near zero temperature coefficient of this material. This will be found especially true of the coils operating at the higher frequencies.

To further guarantee freedom from drift the plate voltage of the high frequency oscillator is regulated by the OB2 VR tube and the heater current of the high frequency oscillator and the mixer is stabilized by a type 4H-4C current regulator tube.

1-10. SIGNAL STRENGTH METER

Signal input readings are indicated in S-units from 1 to 9 and in decibels above S-9 from zero to 40 db. on the

panel-mounted signal strength meter. A reading of S-9 is obtained with an input signal of approximately 25 microvolts. The meter employs a zero to 1 milliamperere movement with its mechanical zero at 40 db. on the dial scale. The S-Meter is connected in series with the plate input of the S-Meter Amplifier tube V-10A and measures the plate current of this tube. With the A.C. supply switch On and the A.V.C. switch set at A.V.C. the S-Meter will read zero in the absence of signal input. A variable resistor is shunted across the meter and with no antenna connected this resistor allows correct adjustment of the pointer to its electrical zero. Any increase in A.V.C. voltage caused by signal input will give a corresponding increase in the meter reading. At the 40 db. meter reading the A.V.C. grid voltage applied reaches the cut-off point of the amplifier tube. Therefore the pointer cannot be harmed by violent contact with the full-scale meter pin. For the purpose of comparing strong signals (which cause the meter to contact the full-scale meter pin) with other stronger and/or weaker signals the sensitivity of the S-Meter may be lowered by retarding the R.F. Gain control. The meter dial lamp illumination is regulated by a Dimmer control mounted on the front panel of the receiver.

1-11. NARROW-BAND F.M. SOCKET

A standard octal socket, X-1, is mounted inside the receiver on the center portion of the power supply compartment chassis. It is designed to mount the National Type NFM-83-50 Narrow-Band F.M. adaptor. A control switch is front-panel mounted to provide a means of switching the audio signal voltage from the A.M. detector to the F.M. discriminator. With the A.V.C. switch set at A.V.C., the S-Meter is operative in the N.F.M. position and the receiver should be tuned for maximum meter reading. Further information concerning the NFM-83-50 unit is contained in a separate data sheet at the rear of this manual.

1-12. CRYSTAL CALIBRATOR SOCKET

The Crystal Calibrator socket, X-2, is of the standard octal type mounted on top of the power supply compartment chassis inside the receiver. It is designed to accommodate a National Model XCU-50-2 Crystal Calibrator. The Model XCU-50-2 is compactly constructed and furnished with a drive screw clamping arrangement to hold it firmly in place. A double-pole, three-position toggle type front-panel mounted Calibrate switch marked 100-Off-1000 provides a means of connecting B-plus to the unit for instantaneous use. At the same time, by using this toggle switch, a resonant crystal-controlled frequency of either 100 or 1000 kcs. may be selected. The output of this unit is coupled to the antenna input. Further information concerning the Model XCU-50-2 unit is covered by a separate data sheet included at the rear of this manual.

1-13. SELECT-O-JECT SOCKET

The Select-O-Ject socket, X-3, is a standard octal type socket accessible at the rear of the receiver. It is primarily designed to accommodate a National Model SOJ-3 Select-O-Ject unit. The mating plug attached to the SOJ-3 permits a direct connection into this socket in place of the audio jumper plug originally plugged into the Select-O-Ject socket. By proper adjustment of the controls any single audio frequency selected in the range of approximately 80 to 10,000 cycles may be boosted or rejected. Detailed instructions for proper operation of the Select-O-Ject are contained with the unit.

For convenience a source of 6.3 V.A.C. filament voltage and a 240 V.D.C. high voltage is available for operation of external apparatus. The Schematic diagram, Figure Number 14, shows a pin view of the Select-O-Ject socket thus providing the information necessary for making the proper connections. External equipment MUST NOT be utilized if the Narrow-Band F.M. adaptor, Crystal Calibrator and Select-O-Ject units are all operated at the same time.

1-14. PHONO INPUT JACK

A Phono jack is mounted at the rear of the Receiver and can be used for connecting auxiliary apparatus, such as a record player pick-up into the audio system of the receiver. This input circuit is of high-impedance providing a suitable match for such external equipment into the high-gain first audio amplifier stage. The front-panel mounted Control switch must be set at the Phono position when using the Phono jack. Both the A.F. Gain and Tone controls are operative with this type of operation.

The majority of record player pick-ups are terminated in a single shielded wire. The Phono jack on the

HRO-60 is the type that accommodates a standard phono tip plug and, if the record player to be used is not fitted with such a plug, one can easily be attached. If the output circuit of the record player is of low impedance (less than 100,000 ohms) improved performance will be obtained if a suitable resistor, with a value as specified for the particular record player, is connected across the phono tip plug or its mating jack to properly load the record player output circuit. Conversely, a resistor of proper value must be used in series with record players whose impedance exceeds 500,000 ohms.

1-15. AUDIO OUTPUT

The HRO-60 features a push pull output amplifier using inverse feed-back. See Figure No. 2 for the audio system response characteristic. The matching transformer located inside the receiver provides two audio outputs as follows:

(1) The transformer secondary leads are brought to a three-terminal Output board located at the rear of the receiver, having both 8 and 500-ohm terminals and a common ground terminal. The eight-ohm terminal provides output for the speaker voice coil. The 500-ohm terminal is available for connection to a 500-ohm line. Approximately 8 watts of undistorted audio output power is available at the output terminal board and a maximum power of 10 watts is obtainable.

(2) A headphones jack is front-panel mounted and is wired so as to silence the loudspeaker upon insertion of the headphones plug. The headphones output load impedance is not critical and varying types of headphones may be used, including crystal types, as no direct current flows through the headphones.

1-16. POWER SUPPLY

The power supply is built in a separate compartment inside the receiver cabinet incorporating a shielded barrier isolating it from the R.F. chassis. It is designed for operation from a 110/120 or 220/240 volt, 50/60 cycle, A.C. supply source. A toggle switch is mounted on top of the chassis for selection of either 110/120 or 220/240-volt operation. Normal power consumption is approximately 115 watts. The built-in power unit supplies all of the voltages required by the heater and B supply circuits, 5.4 amperes at 6.3 volts and 145 milliamperes at 240 volts respectively. In addition, this supply is also capable of furnishing all voltages required by the accessories such as the NFM-83-50, XCU-50-2 and SOJ-3. A 2-ampere fuse is connected in one side of the A.C. input supply to protect the receiver circuits against possible voltage surges in the power line or short circuits in the receiver. It is located at the rear of the receiver and is easily removed for examination or replacement.

A Power Socket, X-4, is provided at the rear of the receiver so that either a battery or vibrator power supply may be utilized for portable or emergency service. The National Type 650S Vibrator Power Supply is designed to provide efficient operation of the receiver with the use of a 6-volt storage battery input. Further information concerning the 650S is contained at the rear of this manual.

1-17. LOUDSPEAKER

The HRO-60TS or HRO-60RS loudspeakers in table or rack mounting styles respectively are designed for use with the receiver. These are both permanent-magnet type loudspeakers furnished with a shielded connecting cable from the 8-ohm voice coil for connection to the output terminal board located at the rear of the receiver. If desirable a 500-ohm shielded line may be used from the receiver output terminals to the speaker and/or externally operated equipment. In the event a dynamic type loudspeaker is used external means for supplying field excitation voltage will be necessary.

A cabinet finished to match the receiver design houses the HRO-60TS loudspeaker for table mounting. The cabinet is lined with sound absorbent material to avoid mechanical resonance.

SECTION 2. INSTALLATION

2-1. GENERAL

All HRO-60 receivers are supplied with the following eight scales mounted on the slide-rule dial drum, irrespective of the type of coil sets ordered, A, B, C, D, E-F, AA, AB and AC. If a coil set or coil sets are ordered with the receiver and the corresponding scale does not appear on the dial drum it will be found packed with the coil set. The new scale is installed in place of any one of the unused scales previously mounted on the dial drum. A Phillips head type screw at one end and a spring clip at the other end of the scale hold it properly in place. The drum scales for the A, B, C and D coil sets are frequency calibrated in megacycles for both of the available ranges i.e., General Coverage and Bandspread. The E and F coil set ranges are on the same scale, while the remaining scales carry just the one frequency range calibrated in megacycles. Each scale is clearly marked with the band designation.

2-2. LOCATIONS

The receiver should not be installed in small, unventilated or warm spaces. Wherever possible placement should be made to allow freedom of air circulation on all four sides. The loudspeaker may be located in any desirable position although it is not recommended that it be placed on top of the receiver as undesirable microphonics may result. The loudspeaker should not be placed near the antenna terminals.

2-3. ANTENNA RECOMMENDATIONS

The radio frequency input of the receiver is designed for operation from either a single-wire antenna or other types employing transmission lines having impedances of 70 ohms or more. There is an antenna terminal panel at the rear of the receiver with three screw-type terminals marked A, A and G respectively. A link is provided on the antenna terminal panel to allow connection of a two-wire or single-wire type antenna to the receiver.

For best impedance matching to the receiver input circuit an antenna with a 300 to 600-ohm transmission line is recommended. The antenna should be cut to the proper length for the most used frequency. The antenna transmission line feeders should be connected to the two antenna terminals marked A; the grounding link is not used. It must be remembered, however, that an antenna installation of this type will have maximum efficiency over a band of frequencies near that frequency for which it is designed and will be most useful in installations where the receiver is tuned to one frequency or band of frequencies. For other frequencies, it would be desirable to connect the two transmission line leads together at the antenna terminal at the left of the antenna terminal panel, grounding the other terminal by means of the link. The antenna is thus utilized as a single wire type.

The most practical antenna for use in installations where the receiver is to be used over a wide range of frequencies is the single-wire type. An antenna length of from 50 to 100 feet is recommended. The antenna lead-in should be connected to the antenna terminal marked A at the left of the antenna terminal panel; the other terminal marked A should be grounded by means of the link.

When a doublet is used, the antenna feeders or balanced transmission line are connected to the two terminals marked A. The grounding link is not used.

The inner conductor of a concentric transmission line should be connected to the terminal marked A at the left of the antenna terminal panel. The outer conductor should be connected to the other terminal marked A and grounded by means of the link to G.

In an installation where the receiver is to be used as the receiving unit in a transmitting station the most efficient operation will result from use of the transmitting antenna as receiving antenna also. This is especially true if the transmitting antenna is of the multi-element, directional type since the same antenna gain is available for both receiving and transmitting - a very desirable condition. For switching the antenna from the receiver to transmitter, an antenna change-over relay should be used. A double-pole, double-throw relay possessing good high-frequency insulation is suitable. A second relay and a three position switch may be used to control the transmitter plate supply and the receiver B+ circuits. This second relay may be a single-pole, single-throw type having one normally open pair of contacts. The schematic diagram of this type of control circuit is shown in Figure 3. With S-1 in the receive position the antenna transmission line is connected to the receiver by contacts

2, 3, 5 and 6 on relay RY-1; the B+ circuit of the receiver is completed by the switch. (The method of connecting the switch to the BSW terminals is given in paragraph 3-1). With the switch in the transmit position RY-1 contacts 1, 3, 4 and 6 are closed transferring the antenna transmission line to the transmitter; contacts 7 and 8 of relay RY-2 close to complete the plate supply circuit to the transmitter. Contacts 7 and 8 of relay RY-2 should be in series with the primary of the transmitter plate supply transformer. Thus, the station is in the receiving condition with switch S-1 in the receive position and in the transmitting condition with S-1 in the transmit position. With S-1 in the mid-position the receiver B+ circuit and transmitter plate supply circuit are both open thus permitting coil set changing in the receiver and transmitter.

NOTE

The high-frequency oscillator, C.W. oscillator, S-Meter amplifier and the push-pull audio output amplifier are not affected by the external relay connection to the B.S.W. terminal board. Unless the A.C. On-Off switch is set at Off these circuits will obtain an uninterrupted B-plus supply.

2-4. A.C. OPERATION

After unpacking the HRO-60 receiver and associated equipment proceed as follows:

- (1) Make sure that all tubes are firmly seated in their sockets and tube clamps are properly in place.
- (2) Make sure the plug-in coil set used in the receiver is firmly in position by pressing down the lever type handles on the front panel to their maximum vertical position.

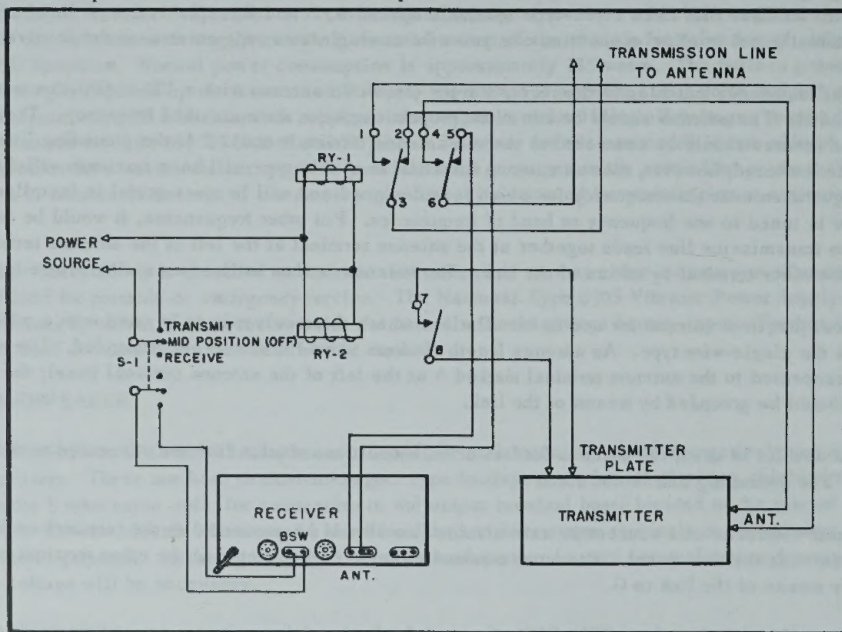

Figure No. 3. Typical Antenna Switching System

- (3) Connect the antenna as recommended in Section 2-2.

(4) Connect the loudspeaker cable to the Output terminal board at the rear of the receiver. This is accomplished by connecting the outer shield lead to the common terminal and the other to the 8-ohm terminal. A 500-ohm terminal is also available on the Output terminal board in cases where a 500-ohm line is utilized for loud-

speaker connection.

(5) Connect the receiver A.C. line cord to the proper source of voltage. The primary switch, S-10, must be set at the position corresponding to the line voltage to be used i.e., 110/120 or 220/240 volts, 50/60 cps.

(6) Set the controls as recommended in Section 3 for reception of signals.

NOTE

Where the receiver is located in the R.F. field of a relatively powerful transmitter, it is advisable to provide some means of preventing damage to the receiver R.F. coil. A normally open SPST relay should be mounted at the back of the receiver adjacent to the antenna terminals and its contacts connected across the terminals. The relay coil should be connected across the transmitter plate primary so that when the transmitter is energized the antenna terminals are shorted.

2-5. BATTERY OPERATION

The HRO-60 is readily adaptable for emergency, portable operation or operation in localities where a 115 or 230-volt A.C. power source is not available. It may be operated directly from batteries or a National Type 650S Vibrator Power Supply designed for operation from a 6-volt storage battery. The type 650S power unit draws 9.5 amperes at 6-volts when furnishing power to the receiver if the Narrow-Band F.M. Adaptor, Crystal Calibrator and Select-O-Ject units are not used. If these plug-in units are utilized typical operating conditions and power consumption data will be found in Section 6.

NOTE

When operating from either battery or vibrator supply the 4H-4C current regulator tube must be removed, to prevent unnecessary battery drain.

The Schematic Diagram, Figure Number 14, illustrates pin connections of the receiver Power Socket X-4. This provides the information necessary for wiring the octal type battery plug which is used in place of the regular A.C. jumper plug. To conserve battery power the battery plug must be disconnected when the receiver is not being used. For standby operation in all cases, it is recommended that a switch be placed in the battery B-plus lead as the B-plus switch in the receiver does not open the B-plus circuit supplying the high-frequency oscillator C.W. oscillator, S-Meter Amplifier or the push-pull audio output tubes. A suggested refinement is to include a switch in the A-plus input lead so that the tube heaters may be turned off when the receiver is not in use without the necessity of removing the battery plug from the Power socket. When using vibrator supply 650S the switch mounted on the power supply may be used.

2-6. ACCESSORY SOCKETS

Three octal type sockets are available for additional accessories as follows:

(1) A N.B. F.M. socket, X-1, is mounted on top of the chassis inside the power supply compartment. A National Type NFM-83-50 Narrow-Band F.M. adaptor is designed to fit into this socket and is supplied with a mounting bracket and drive screws to hold it firmly in place. The front panel mounted control switch, S-7, provides a means of switching the NFM-83-50 unit into instant service as required.

(2) A Crystal Calibrator socket, X-2, is top chassis mounted in the power compartment. This socket is wired to accommodate a National plug-in Type XCU-50-2 Crystal Calibrator unit. A slotted head screw arrangement bolts the unit firmly in place. The front panel Calibrate switch provides a means of applying B-plus to the unit as well as the selection of either a 100 or 1000 kc. marker signal.

(3) A Select-O-Ject socket, X-3, of the standard octal type is mounted so as to be accessible from the rear of the receiver. This socket is designed primarily for the use of a National Model SOJ-3 Select-O-Ject unit. The SOJ-3 is fitted with an interconnecting cable and plug for direct connection to the Select-O-Ject socket.

Reference to the Schematic Diagram will show the various connections made to the socket if it is desired to use the voltages available for accessories other than the Select-O-Ject. It will be noted that B+ (240 V.D.C.) and filament voltages are available. There is a definite limitation on the drain permissible at this socket. The total permissible drain (if the NFM-83-50, XCU-50-2 and SOJ-3 are not used) is 1.8 amps at 6.3 V.A.C., 10 milliamperes at 240 V.D.C.

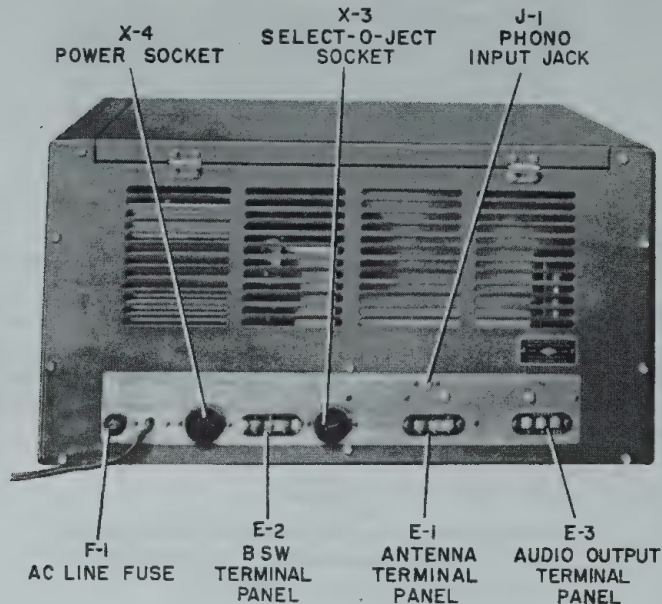

Figure No. 4. Rear View of Receiver

SECTION 3. OPERATION

3-1. CONTROLS

All controls are identified by front-panel markings for ease of identification. The controls are located in a symmetrical manner and are arranged for ease of operation.

The main tuning HRO type micrometer dial is arranged so that the frequency to which the receiver tunes increases as the dial reading increases. The slide-rule dial pointer mechanism is synchronized with the main tuning dial using an anti-backlash gear plus an efficient string-drive arrangement to provide an accurate relationship between the main tuning dial and the direct frequency calibrated scales on the slide-rule drum assembly. Front-panel mounted is a Band selector control for rotating the proper scale into place for the coil set to be used.

The R.F. Gain control serves to adjust the amplification of the second R.F., first, second and third I.F. amplifier stages. Maximum sensitivity is obtained by rotating the control knob to the extreme clockwise position (10 on its circular scale). At the extreme clockwise position all tubes are operating at maximum gain with minimum bias. As the control is rotated counter-clockwise, increasing bias is applied to the cathodes of the second R.F., first, second and third I.F. tubes, thus reducing their amplification.

The A.C. On-Off switch is associated with the A.F. Gain control and A.C. power is turned on as the A.F. Gain control is advanced from A.C. Off to zero on its scale.

The B+ On-Off switch is connected in the positive lead of the power supply circuit and its purpose is to disconnect the B-plus during periods of transmission or WHEN CHANGING COIL SETS. This last function is important. The B+ circuits are completed when the switch is set at On. However, the B-plus circuits of the high-frequency oscillator, S-Meter amplifier, C.W. oscillator and push-pull audio output tubes remain On at all times regardless of the position of the B+ On-Off switch providing the A.C. On-Off switch is set at On.

Mounted at the rear of the chassis is a three connector terminal board marked B.S.W. This allows relay control of the receiver by either of two methods. As shipped from the factory a jumper is connected between terminals 2 and 3. A relay connected between terminals 1 and 2 and energized by the station transmit-receive switch will turn the receiver B+ on and off provided the receiver B+ switch is in the OFF position. In other words the relay contacts are connected in parallel with the B+ switch. The relay may be connected in series with the switch by removing the jumper between terminals 2 and 3 and connecting the relay contacts to terminals 2 and 3. The relay then controls the receiver when the B+ switch is in the ON position. The B.S.W. panel is covered by a metal shield to prevent accidental contact with the terminals by the operator. Two slots are provided in this shield to bring out wires to connect to the relay. Care should be taken that these wires for external connection do not short to the B.S.W. shield.

The Phasing control and Selectivity switch are part of the crystal filter. When the Selectivity switch is set at Off the crystal is switched out of the circuit. With the crystal switched out the Phasing control has no influence on receiver performance. With the Selectivity switch set at any point between 1 and 5, inclusive, the crystal filter is in operation, selectivity increasing as the switch is progressively advanced to position 5. The Phasing control is then used to balance the crystal bridge circuit and eliminate interfering signals or heterodynes. It is recommended that the Tone control be rotated counter-clockwise until the switch is turned Off. This will provide optimum reception of the high audio frequencies when using the crystal filter for A.M. reception. The resultant boost of the higher frequencies tends to compensate for the side band cutting action of the crystal filter.

The C.W. oscillator is turned on by setting the front-panel mounted Control switch at the C.W. position. The C.W.O. control provides a vernier tuning adjustment for the C.W. oscillator transformer. This oscillator is used to produce an audible beat note when receiving C.W. signals or to locate the carrier of a weak phone station. With the Control switch set at the C.W. position, B-plus is applied to the C.W. oscillator tube providing a constant B-plus supply regardless of the B+ On-Off switch setting or the B.S.W. external control devices. Normally the C.W.O. control is set at zero, however by rotating it either to the right or left of zero the operator can select an audio tone suitable to the ear, or he may set the control for best reception. The C.W. code characters are made audible through the heterodyning action of the C.W. oscillator with that of the incoming signal. Care should be taken to retard the R.F. Gain control to a point where the receiver does not overload.

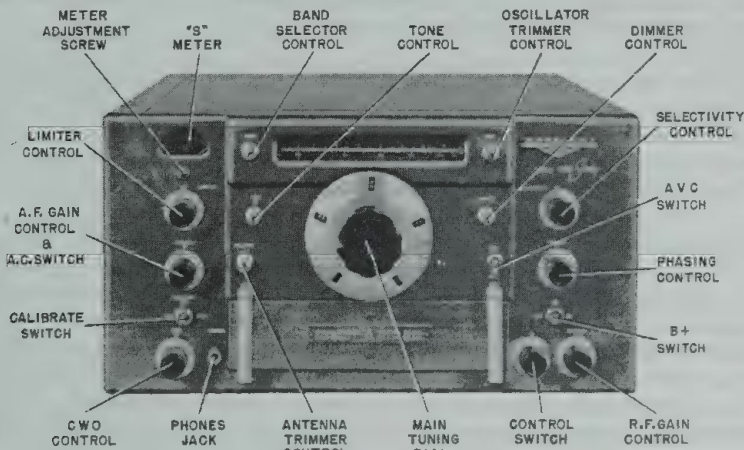

Figure No. 5. Front View of Receiver

The Limiter control serves to switch on the limiter and, following this, to adjust the threshold at which limiting action starts. With the Limiter control turned on (at position 0 on the dial scale) limiting action automatically takes place at a relatively high percentage modulation. Rotating the control clockwise progressively lowers the threshold, or percentage modulation, at which limiting action starts until maximum clipping is achieved at 10. This limiter is double-acting in that limiting is accomplished by clipping of both positive and negative peaks. Limiting action is equally effective for both phone or C.W. reception.

The Tone control is used to vary the audio frequency characteristic of the audio system. A switch mounted on the control is turned Off by maximum counterclockwise rotation of the control and provides maximum low frequency attenuation. Rotating the control just enough to turn the switch On provides a comparatively flat response over the entire usable audio frequency range. Rotating the control further in a clockwise direction will attenuate the high audio frequencies affording an improvement in readability when the signal is weak and partially obscured by background noise. Excessive attenuation of these frequencies, however, may result in an impairment of A.M. speech intelligibility. When receiving C.W. signals it will be possible to advance the Tone control considerably further than is possible in A.M. reception since audio fidelity is relatively unimportant.

The A.V.C. switch is a two-position toggle marked A.V.C.-Off. The automatic volume control circuits are operative with the toggle switch in the A.V.C. or upper position.

The A.F. Gain control adjusts the volume level of the signal at both the Phones jack and loudspeaker terminals. Clockwise rotation of this control increases the signal applied to the grid of the first audio amplifier tube. The A.F. Gain control is operative when an audio signal is applied to the Phono input jack with the Control switch set at the Phono position.

A Bandsread switch is mounted on the A, B, C and D coil sets. Inspection of the coil set ceramic terminal panel will show a silver-plated spring metal strip with a slotted center screw. Four silver-plated contacts are provided on the terminal panels; two for each type of reception i.e., General Coverage or Bandsread. The metal strip may be turned either to the right or left thereby selecting the type of reception required. A spring tension detent arrangement provides for proper placement and a firm trouble-free electrical contact in each position. It is only necessary to switch this from the right to the left hand side to change from General Coverage to Bandsread. The lower calibrated scale on the slide rule dial is used when operating in the Bandsread position. A typical coil set showing adjustment locations is illustrated in Figure Number 7 contained in Section 4.

The Ant. Trim. control operates a tuning capacitor which is connected across the first R.F. amplifier section of the main tuning capacitor. This trimmer control is used to tune the first R.F. amplifier stage properly under a wide variety of antenna loading conditions over the entire frequency range of the receiver.

The Dimmer control is a variable resistor actuated by a front-panel mounted knob. It is connected in series with one of the filament supply wires to the S-Meter and slide-rule dial pilot lamps and furnishes a means of varying the degree of illumination as desired by the operator.

The front-panel mounted Osc. trimmer control drives a variable air capacitor connected in parallel with the oscillator main tuning capacitor. Assuming that the receiver is properly aligned this compensating trimmer may be used for minor calibration adjustments. Calibration can be checked by the use of accurate crystal-controlled test oscillators or by using the National Model XCU-50-2 Crystal Calibrator. Use of the Osc. trimmer should not be attempted until the receiver has had a warm-up period of at least five minutes.

A four-position Control switch is mounted on the front panel of the receiver. In the C.W. position, the C.W. oscillator is placed in operation. The A.M. position provides normal reception of phone or broadcast signals. In the N.F.M. position the reception of narrow-band F.M. signals is possible provided a National Type NFM-83-50 adaptor is plugged into the N.B.F.M. socket. With the Control switch in this position the adaptor is connected between the output of the intermediate amplifier and the input of the audio system. When the control switch is set in the Phono position, the Phono jack is connected to the input of the audio amplifier. In the Phono position all of the receiver circuits except the audio system are rendered inoperative. The A.F. Gain and Tone controls remain operative. If it is so desired the record player may remain connected to the receiver and normal receiving operation resumed by setting the Control switch to any of the other positions.

3-2. PHONE RECEPTION

After the HRO-60 is properly installed as outlined in Section 2, it is placed in operation by the following adjustments:

1. Set the Control switch at A.M.
2. Set the A.V.C. switch at A.V.C.
3. Set the Selectivity switch at Off.
4. Set the Phasing control at zero.
5. Set the Limiter control at Off.
6. Set the R.F. Gain control at 10.
7. Check the position of the Osc. trimmer control pointer. It is aligned at the factory so that proper calibration is obtained with the pointer in a vertical position with the arrow head uppermost.
8. Turn the A.C.-On-Off switch mounted on the A.F. Gain control to On i.e., zero on the dial scale.
9. Set the receiver B+ switch at On.
10. Adjust the Band control to select the scale corresponding to the plug-in coil set in use.
11. Turn the A.F. Gain control to the position giving the desired audio volume.
12. Adjust the Ant. Trim. control for a maximum S-Meter reading after the desired station has been selected. Alternately in the absence of a signal the Ant. Trim. control may be set for maximum receiver background noise.
13. Turn the Tone control to a position giving the desired audio output response.

The receiver is now adjusted for the reception of phone signals and will tune to the frequency corresponding to the plug-in coil set in use and the setting of the main tuning dial. If a dual-coverage plug-in coil set is used the position of the Bandsread switch, as previously described in paragraph I of this section, will determine the frequency coverage i.e., General Coverage or Bandsread.

The settings given above are for the reception of signals of average strength. Exceptionally strong or weak signals may require modification of the above settings. The operator must remember that automatic volume control action will be restricted unless the R.F. Gain control is fully advanced. Audio output should be adjusted entirely by means of the A.F. Gain control.

Various types of interference which may be encountered due to adverse receiving conditions can be minimized by utilization of the following controls in the manner described.

Noise Limiter - When a signal is accompanied by static peaks or noise pulses of high intensity and short duration, the best signal-to-noise ratio will be obtained by turning On the Limiter control. In general, it will be found that turning the Limiter control On to 0 on the dial scale will effectively minimize interference caused by external noise pulses. In cases where the noise pulses are extremely pronounced a higher degree of noise suppression will be realized by advancing the Limiter control to a higher dial setting.

Tone control - An improvement in signal-to-noise ratio can be realized by setting the Tone control to attenuate the high audio frequencies. When receiving weak signals which are partially obscured by background noise or static an improvement in reception will be noticed by rotating the Tone control in a clockwise manner. However, too much attenuation of the high audio frequencies may impair the intelligibility of speech.

Selectivity and Phasing - The selectivity of the receiver is adjusted by means of the crystal filter Selectivity switch. The normal setting of the Selectivity switch in phone or broadcast reception is at one of the positions affording broad selectivity. Positions marked Off, 1 or 2 are recommended. Selectivity may be progressively increased by turning the Selectivity switch to position 3, 4 or 5. Increasing selectivity will result in the attenuation of the higher audio frequency tones of the signal as well as sharper tuning. If the selectivity is increased too much, these higher frequency audio tones will be attenuated to such an extent that phone or broadcast signals may become unintelligible due to excessive side-band cutting. The Phasing control is part of the crystal filter and is used to eliminate or attenuate interfering heterodynes. The Phasing control is inoperative with the Selectivity switch set in the Off position but is operative in all other settings. The normal setting of the Phasing control with the crystal filter On (i.e., the Selectivity switch set at 1, 2, 3, 4 or 5) in phone reception is at zero on its scale. If, after a desired signal has been tuned in, an interfering signal causes a heterodyne or whistle the Phasing control should be adjusted until this interference is reduced to a minimum. The set-

ting of the Phasing control should be that which provides a maximum attenuation of the objectionable heterodyne. If the heterodyne is below 1,000 cycles the optimum Phasing control setting will be near either one or the other end of the dial scale, depending upon whether the interfering signal has a higher or lower frequency than the desired signal.

3-3. C.W. RECEPTION

The initial adjustment of the receiver controls for C.W. reception is the same as given in Section 3-2 except that the Control switch must be set at C.W. The C.W. oscillator should be set at zero and the A.F. Gain well advanced.

The audio level of the receiver should be adjusted by means of the R.F. Gain control, care being taken not to advance the control to the point where strong signals will cause I.F. or audio amplifier overload, as indicated by excessive thumping.

For the reception of C.W. signals the action of the crystal filter is similar to that for phone reception except that full use of the sharp selectivity position may be used without the loss of intelligibility experienced in phone reception. When maximum selectivity is used, (Selectivity switch at position 5) care must be exercised since tuning is very critical. When the receiver is slowly tuned across the carrier of the received signal the beat-note produced will be very sharply peaked in output at a particular audio pitch. This peak in response indicates the correct receiver dial setting. The setting of the C.W.O. control must be such that the beat-note peak is well within the audible range so that the receiver peak response may be readily observed. A C.W.O. dial setting near zero is recommended. After the receiver has been correctly tuned, the pitch of the beat-note peak may be adjusted by means of the C.W.O. control to provide an audio tone which is pleasing to copy or coincides with any response peaks in the speaker or headphones. Under these conditions the receiver will exhibit pronounced single-signal properties which may be demonstrated by tuning the receiver to the other side of 'zero-beat' so that the pitch is the same as before and observe the marked reduction in output. This dial setting is not recommended for use other than to demonstrate the single-signal properties of the receiver. With the receiver tuned to 'crystal peak', an interfering signal may be attenuated by proper setting of the Phasing control since this control has little effect on the desired signal.

Similar to phone reception the Limiter control can be used to great advantage in C.W. reception for the reduction of interference due to external noise pulses. For C.W. reception, however, the Limiter control may be set at a well advanced position on the dial scale as excessive clipping of the modulation peaks will not be experienced as might be the case in phone reception. Also the Tone control may be advanced considerably further for C.W. reception since audio fidelity is relatively unimportant.

3-4. N.B.F.M. OPERATION

The HRO-60 receiver is adaptable for Narrow-Band F.M. reception by utilizing a National Type NFM-83-50 Narrow-Band F.M. adaptor. Operating instructions as given in paragraph 3-2 of this section are applicable for the reception of narrow-band F.M. signals except that the control switch must be set at N.F.M. It is recommended when the operator is scanning a band for signals that the control switch is set at A.M. An F.M. signal is indicated by the presence of an audio null in the center of the signal carrier. When an F.M. signal is encountered the Control switch should then be set at N.F.M. and with the A.V.C. switch set at A.V.C. the signal tuned for maximum S-Meter reading.

NOTE

The pass band of the NFM-83-50 is sufficiently wide to accommodate any narrow band FM signal so long as the transmitter is held within recommended deviation limits. If excessive peak deviation occurs at the transmitter distortion will result in the receiver when the adaptor is in use even though the signal appears undistorted when using A.M. slope detection.

3-5. MEASUREMENT OF SIGNAL STRENGTH

Extremely high gain has been incorporated within the HRO-60 to insure optimum sensitivity over a wide range of operating conditions. This additional gain results in higher than normal S-Meter readings when the conventional method of control adjustment is used. Very accurate signal strength measurements may be obtained by the following procedure:

1. Set the R.F. Gain control at 10, the Control switch at A.M. and the A.V.C.-OFF switch at A.V.C.
2. Set the Selectivity switch at Off and the Phasing control at zero. The Limiter, Tone and A.F. Gain controls do not affect the S-Meter reading.
3. Tune the receiver off the signal so that the S-Meter is reading only background noise.
4. Retard the R.F. Gain control until the meter reads S-1.

Tune in the desired signal and the S-Meter will indicate the exact strength of the received signal in S-units from 1 to 9 or in decibels above the S-9 level from zero to 40 db. These readings will remain accurate until the R.F. Gain control is moved or a different coil set plugged in.

The S-Meter circuit compensator requires adjustment only when it is impossible to obtain a zero reading with no antenna connected and the R.F. Gain at zero. See Section 4-7 for adjustment procedure.

Design of the S-Meter actuating circuit is such that a signal stronger than 40 db. above S-9 cannot cause the meter pointer to come into violent contact with the full-scale meter stop pin thus preventing the possible bending of the meter pointer.

Measurements of the signal strength of C.W. signals cannot be made with the C.W. oscillator in operation.

With the receiver A.C.-On-Off switch set at Off the meter pointer will return to its mechanical zero located on the right hand or 40 db. end of the meter.

SECTION 4. ALIGNMENT DATA

4-1. GENERAL

All circuits in the HRO-60 receiver are carefully aligned before shipment using precision test equipment insuring accurate conformability to the alignment frequency. No realignment of the various adjustments will be required unless the receiver is tampered with or component parts or tube replacements have been necessary.

A definite need for realignment can be determined by checking the performance of the receiver against its normal operation as outlined in Section 3. A simple check to assure the need of realignment of the I.F. Amplifier is provided in paragraph 4-2 of this section. In no case should realignment be attempted unless tests indicate that such realignment is necessary. Even then it must be remembered that the HRO-60 is a communications receiver and should not be serviced or realigned by any individual who does not have a complete understanding of the functioning of the equipment and who has not had previous experience adjusting receivers of this type.

Complete alignment of the receiver can be divided into four steps as follows:

- (a) Intermediate Frequency Amplifier alignment including crystal filter adjustments.
- (b) Second Conversion Circuit Alignment.
- (c) General Coverage Alignment.
- (d) Bandsread Alignment.

All circuits must be tuned in the above order when complete alignment is required. All alignment adjustments and controls are shown on Figures 6, 7 and 10b.

4-2. I.F. AMPLIFIER ALIGNMENT

The second intermediate frequency of the HRO-60 is 455 kilocycles plus or minus 2 kilocycles. The exact

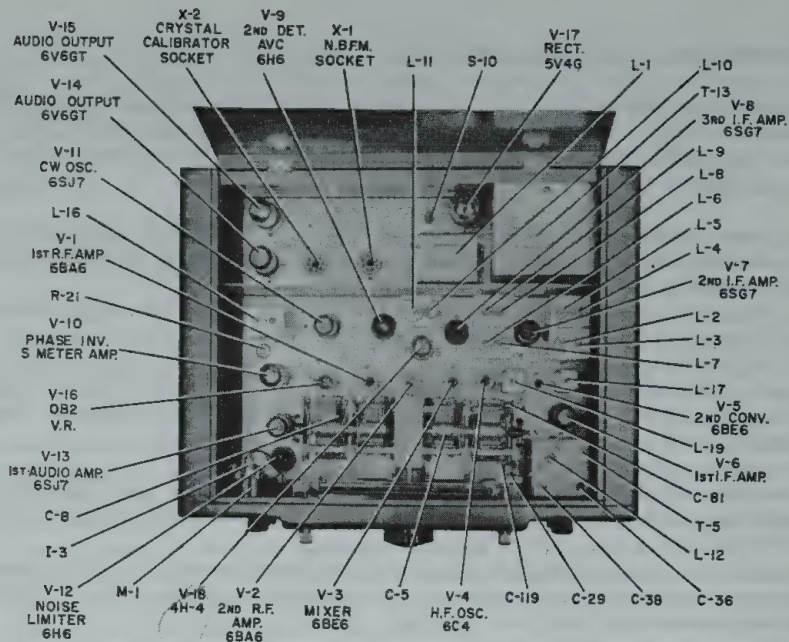

Figure No. 6. Top View of Receiver

frequency is determined by the quartz crystal resonator, Y-1, used in the crystal filter. Variable trimmer capacitors and variable iron-core inductors are used to effect alignment. These adjustments are located on Figures 6 and 10b.

The preliminary alignment procedure is as follows:

- (1) Plug in the D range coil-set.
- (2) Connect the high output lead of an accurately calibrated signal generator to the stator of the mixer section of the main tuning capacitor, C-5C, and the ground lead to the capacitor frame.
- (3) Connect an output meter having an 8 or 500 ohm resistive load to the matching output terminals on the receiver. As an alternative a high-impedance A.C. voltmeter may be connected to the phones jack.
- (4) Set the Control switch at C.W.
- (5) Set the A.V.C. switch at Off.
- (6) Set the Phasing control at zero.
- (7) Set the Selectivity switch at 5.
- (8) Set the A.F. Gain control at 10.
- (9) Set the R.F. Gain control at 9.
- (10) Turn the modulation of the signal generator off to provide a steady C.W. test signal tuned to approximately 455 kilocycles.

Adjust the output attenuator of the signal generator to provide a signal of approximately 100 microvolts. The C.W.O. control must be set to provide an audio beat-note at some frequency between 400 and 1000 cycles per second. The presence of this beat note can readily be determined by temporarily connecting headphones or a loudspeaker to the receiver. If difficulty is encountered in obtaining such a beat note an adjustment of the C.W.O. inductor L-16 must be made.

Vary the tuning control of the signal generator very slowly between the frequencies of 453 and 457 kilocycles. At one frequency between these limits the I.F. amplifier of the receiver will show a very definite sharply peaked response as indicated on the output meter. This frequency is that of crystal Y-1, and I.F. alignment is made at this frequency.

A simple check of this frequency setting would be to adjust the C.W.O. control until a point is found where the predominant pitch of the background noise is lowest and a distinct crystal ring is heard. Note this setting of the C.W.O. control. Disconnect the crystal filter from the circuit by turning the Selectivity switch to the Off position. Once more adjust the C.W.O. control for the lowest predominant pitch of background noise and note the setting. If the I.F. amplifier is correctly aligned to the crystal frequency the C.W.O. control setting will be the same for both tests outlined above.

While making I.F. amplifier adjustments it will be necessary to retard the attenuator of the signal generator if I.F. amplifier gain increases to a point where overload occurs. Without altering the frequency setting of the signal generator, set the Selectivity switch at Off, the Control switch at A.M. and turn the modulation of the signal generator On. Inductors L-2 through L-11 should at this point each be carefully adjusted to give a maximum reading on the output meter. The order in which these adjustments are performed is not important.

Upon completion of the above adjustments set the Selectivity switch at 1. Set the frequency of the signal generator 2 kilocycles higher and adjust the crystal filter inductor L-13 for a maximum output meter indication. After making this adjustment set the selectivity control at Off and return the signal generator to the exact crystal frequency (2 kilocycles lower). Tune the Selectivity compensating trimmer capacitor C-38 for a maximum reading of the output meter.

The Phasing control as set at the factory should need no further attention. When correctly set a predominant decrease in background level will be found with the Selectivity switch at position 5 and the Phasing control at zero. This same null point should be found by rotating the Phasing control exactly 180 degrees. If not, a slight adjustment of the phase balancing capacitor C-36 will provide the proper setting.

Turn the modulation of the signal generator Off and set the Control switch at C.W. Set the C.W.O. control to zero beat with the signal generator signal. If zero beat does not occur at 0 on the control dial carefully readjust inductor L-16 of the C.W. oscillator transformer T-11.

4-3. SECOND CONVERSION CIRCUIT ALIGNMENT

The first I.F. frequency of the HRO-60 when using double conversion is 1990 kilocycles plus or minus 3 kilocycles. The correct alignment procedure is as follows:

1. Leave the signal generator connected to the mixer section of the tuning capacitor and the output meter connected to the output terminals of the receiver as in paragraph 4-2.
2. Set the Control switch at A.M.
3. Set the A.V.C. switch at Off.
4. Set the Phasing control at zero.
5. Set the Selectivity switch at Off.
6. Set the A.F. Gain control at 10.
7. Set the R.F. Gain control at 9.
8. Turn the modulation of the signal generator on to provide a modulated test signal tuned to exactly 1990 kilocycles.
9. Plug in the B range coil set.
10. Adjust L-17 for a distinct peak as indicated on the output meter. If L-17 is badly misaligned spurious signals will be found in addition to the desired signal. The proper tuning point will give a peak reading of much higher value than will the incorrect coil settings and is easily determined.
11. Adjust L-18 and L-19 for maximum reading of the output meter.

NOTE

A comparison of the output meter readings taken in Paragraph 4-3 with those of Paragraph 4-2 will show a much lower output level for the double conversion set-up. This is due to the shunting effect of the B-range coil upon the signal generator output and in no way indicates a

loss of stage gain. The method for obtaining stage gain measurements is discussed in Paragraph 5-3.

4-4. GENERAL COVERAGE ALIGNMENT

The data given in this section applies to the General Coverage alignment of the H.F. oscillator and R.F. amplifier stages of all coil sets. The original alignment at the National Laboratories is accomplished by the use of precision, crystal-controlled test oscillators. No realignment should be attempted unless a reliable test signal source is available. In the case of General Coverage H.F. oscillator alignment, a test signal source with an accuracy of 0.1% or better is required. For Bandsread alignment the calibration accuracy demands that the test signal source have the accuracy of precision-calibrated crystals. The entire range of test frequencies required may be obtained by the use of nine crystals operating at their fundamental and harmonic frequencies. The frequency of these crystals is as follows: 0.05, 0.1, 1.0, 2.0, 3.5, 5.0, 6.8, 7.0, 7.3, 9, 14.4, 15 and 16 megacycles.

If an XCU-50-2 crystal calibrator is installed in the HRO-60 at this time it will provide an excellent means of checking the calibration at 100 kc. or 1000 kc. points.

The need for realignment of the H.F. oscillator of any band is indicated when the frequency calibration of the receiver dial is in error by more than 1% at the high frequency end of the band in question. If it is determined that realignment is necessary proceed as follows:

- (1) Connect an output meter to the receiver as described in paragraph 4-2 of this section and disconnect the antenna.
- (2) Set the Control switch at A.M.
- (3) Set the A.V.C. switch at Off.
- (4) Set the Selectivity switch at Off.
- (5) Set the R.F. Gain control at 10.
- (6) Set the Bandsread switches in the General Coverage position.
- (7) Set the A.F. Gain control to provide a suitable output level.
- (8) Check the position of the Ant. Trim. and Osc. trimmer controls. Alignment should be made with both of the pointers on these controls in a vertical position with the arrow-head pointed towards the top of the receiver.

The following Alignment chart gives a step-by-step procedure to follow in effecting the General Coverage alignment of each coil set. It is important that the chart of adjustments is adhered to in the order shown. It will be noted that General Coverage alignment affects Bandsread alignment, but that adjustment of Bandsread alignment does not affect General Coverage.

Particular care must be taken when adjusting the high-frequency oscillator trimmer C-26 in each coil set. Three different checking procedures must be followed. The coil sets below 7 megacycles must be adjusted so that the oscillator frequency is higher than the R.F. frequency and the image should be located 910 kc. below the fundamental on the dial. The oscillator for the ranges between 7 megacycles and 35 megacycles is set to the higher frequency but its image would appear 3980 kc. below the fundamental. In some cases this will fall outside the range of the coil set so special procedures must be used. In the 50 to 54 megacycle coil set the oscillator must be trimmed to a frequency lower than the fundamental. The method for making these checks follows:

1. When trimming the oscillator in a coil set below 7 megacycles turn the receiver dial 910 kilocycles below the test frequency. If the image does not appear at this point the oscillator is incorrectly adjusted and the capacity of the trimmer must be reduced until the fundamental and the image appear at their proper dial locations.
2. When trimming the oscillator of any coil set in the range between 7 and 35 megacycles the image must be located 3980 kilocycles below the fundamental. Since this frequency will be outside the range of the coil set in some cases the only alternative is to leave the receiver tuned to the fundamental and raise the signal generator output frequency 3980 kilocycles. It will probably be necessary to increase the generator output to make the image readable since rejection will be as high as 90 db. in most coil sets. The image of the signal from the generator must appear at the present receiver dial setting to indicate proper oscillator setting.
3. The oscillator in the AD coil set must be trimmed to the low-side of the R.F. signal. In this instance the image must be located 3980 kc. above the fundamental. Leave the receiver tuned to the fundamental and lower the generator frequency 3980 kc. The generator output may have to be increased to make the image readable.

The image must be located at this point or the oscillator trimmer is incorrectly adjusted.

After the high-frequency oscillator is correctly calibrated the R.F. amplifier trimmers C-2 and C-15 and the mixer trimmer C-21 should be adjusted for maximum receiver gain as measured by the output meter. Coil sets A and D do not use a first R.F. amplifier trimmer but are peak tuned by the use of the Ant. Trim. control over the full frequency range of each coil set. It may be desirable to align the R.F. Amplifier trimmers C-2 and C-15 and the mixer trimmer C-21 using receiver background noise as an indication of maximum gain, rather than the signal source. If this alternate method of alignment is used the point of maximum gain is that setting of the trimmers which provides the loudest receiver background noise. However, it is possible to align the R.F. amplifier and mixer stages to the image frequency using background noise as an indicator. A check of this possibility is to tune in the image signal - if the image is weaker than the fundamental signal R.F. amplifier and mixer stages are correctly aligned.

Correction of tracking errors of the R.F. amplifier and mixer stages at the low frequency limit of each coil set is accomplished by the adjustments listed on the Alignment Chart. The actual tracking of these stages may be checked by pressing the outside rotor plates of the main tuning capacitor section toward or away from the stator in a manner assuring that the rotor plates will spring back to their original position. Any change in capacity should decrease the receiver gain if the stage is tracking properly.

The locations of the adjustments referred to on the General Coverage Chart are shown on Figure Number 7. Each variable on the chart is followed by a number in parenthesis to identify its position on the respective coil set. Schematic diagrams of each of the plug-in coils sets are furnished on Figure Numbers 11, 12 and 13.

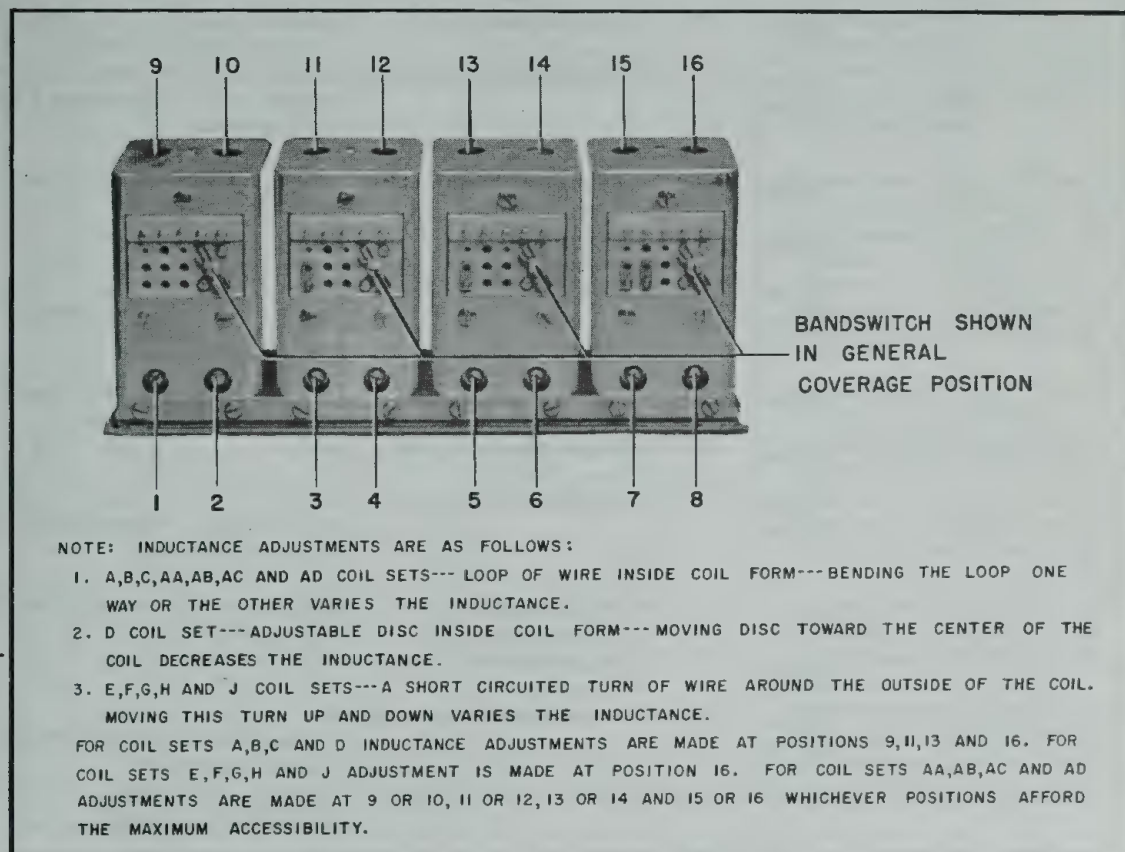

Figure No. 7. Typical Coil Set Showing Alignment Adjustment Locations

GENERAL COVERAGE CHART

Step	Coil Set	Adjust Signal Source and Receiver to:	Adjust to Receive Test Signal	Adjust for Maximum Output
1	A	30.0 Mc.	Trimmer capacitor C-26 (Pos. 8)	Trimmer capacitors C-21 (Pos. 6), C-15 (Pos. 4).
2	A	14.4 Mc.	Inductance at Pos. No. 16.	Inductance at Pos. Nos. 13, 11, 9. Check step 1. Repeat steps 1 and 2 if necessary
3	A	30.0 Mc.		
1	B	14.4 Mc.		
2	B	7.0 Mc.	Inductance at Pos. No. 16.	Inductance at Pos. Nos. 13, 11, 9. Check step 1. Repeat steps 1 and 2 if necessary.
3	B	14.4 Mc.		
1	C	7.3 Mc.		
2	C	3.5 Mc.	Inductance at Pos. No. 16.	Inductance at Pos. Nos. 13, 11, 9. Check step 1. Repeat steps 1 and 2 if necessary.
3	C	7.3 Mc.		
1	D	4.0 Mc.		
2	D	1.8 Mc.	Inductance at Pos. No. 16	Inductance at Pos. Nos. 13, 11, 9. Check step 1. Repeat steps 1 and 2 if necessary.
3	D	4.0 Mc.		
1	E	2.0 Mc.		
2	E	1.0 Mc.	Padder capacitor C-100 (Pos. 7).	Check step 1. Repeat steps 1, 2 and 3 if necessary.
3	E	1.4 Mc.	Inductance at Pos. No. 16.	
4	E	2.0 Mc.		
1	F	0.9 Mc.		
2	F	0.5 Mc.	Padder capacitor C-100 (Pos. 7).	Check step 1. Repeat steps 1, 2 and 3 if necessary.
3	F	0.7 Mc.	Inductance at Pos. No. 16.	
4	F	0.9 Mc.		
1	G	400 Kc.		
2	G	200 Kc.	Padder capacitor C-100 (Pos. 7).	Check step 1. Repeat steps 1, 2 and 3 if necessary.
3	G	300 Kc.	Inductance at Pos. No. 16.	
4	G	400 Kc.		

GENERAL COVERAGE CHART (CONT'D)

Step	Coil Set	Adjust Signal Source and Receiver to:	Adjust to Receive Test Signal	Adjust for Maximum Output
1	H	200 Kc.	Trimmer capacitor C-26 (Pos. 8).	Trimmer capacitors C-21 (Pos. 6), C-15 (Pos. 4), C-2 (Pos. 2). Check step 1. Repeat steps 1, 2 and 3 if necessary.
2	H	100 Kc.	Padder capacitor C-100 (Pos. 7).	
3	H	150 Kc.	Inductance at Pos. No. 16.	
4	H	200 Kc.		
1	J	100 Kc.	Trimmer capacitor C-26 (Pos. 8).	Trimmer capacitor C-21 (Pos. 6), C-15 (Pos. 4), C-2 (Pos. 2). Check step 1. Repeat steps 1, 2 and 3 if necessary.
2	J	50 Kc.	Padder capacitor C-100 (Pos. 7).	
3	J	75 Kc.	Inductance at Pos. No. 16.	
4	J	100 Kc.		
1	AA	30 Mc.	Trimmer capacitor C-26 (Pos. 7).	Trimmer capacitors C-21 (Pos. 5), C-15 (Pos. 3), C-2 (Pos. 1). Padder capacitors C-99 (Pos. 6), C-98 (Pos. 4), C-97 (Pos. 2). Inductance at Pos. Nos. 13, 11, 9. Check step 1. Repeat steps 1, 2 and 3 if necessary.
2	AA	27.2 Mc.	Padder capacitor C-100 (Pos. 8).	
3	AA	28 Mc.	Inductance at Pos. No. 16.	
4	AA	30 Mc.		
1	AB	35 Mc.	Trimmer capacitor C-26 (Pos. 8).	Trimmer capacitors C-21 (Pos. 6), C-15 (Pos. 4), C-2 (Pos. 2). Padder capacitors C-99 (Pos. 5), C-98 (Pos. 3), C-97 (Pos. 1). Inductance at Pos. Nos. 13, 11, 9. Check step 1. Repeat steps 1, 2 and 3 if necessary. Check step 1.
2	AB	25 Mc.	Padder capacitor C-100 (Pos. 7).	
3	AB	30 Mc.	Inductance at Pos. No. 16.	
4	AB	35 Mc.		
1	AC	21.5 Mc.	Trimmer capacitor C-26 (Pos. 7).	Trimmer capacitors C-21 (Pos. 5), C-15 (Pos. 3), C-2 (Pos. 1). Padder capacitors C-99 (Pos. 6), C-98 (Pos. 4), C-97 (Pos. 2). Inductance at Pos. Nos. 13, 11, 9. Check step 1. Repeat steps 1, 2 and 3 if necessary. Check step 1.
2	AC	21 Mc.	Padder capacitor C-100 (Pos. 8).	
3	AC	21.3 Mc.	Inductance at Pos. No. 16.	
4	AC	21.5 Mc.		
1	AD	54 Mc.	Trimmer capacitor C-26 (Pos. 7).	Trimmer capacitors C-21 (Pos. 5), C-15 (Pos. 3), C-2 (Pos. 1). Padder capacitors C-99 (Pos. 6), C-98 (Pos. 4), C-97 (Pos. 2). Inductance at Pos. Nos. 13, 11, 9. Check step 1. Repeat steps 1, 2 and 3 if necessary. Check step 1.
2	AD	50 Mc.	Padder capacitor C-100 (Pos. 8).	
3	AD	52 Mc.	Inductance at Pos. No. 16.	
4	AD	54 Mc.		

4-5. BANDSPREAD ALIGNMENT

The data given in this section applies to the Bandspread Alignment of the high-frequency oscillator, R.F. amplifier and mixer stages of coil sets A, B, C and D. It is important that no Bandspread adjustments are made until after completion of General Coverage alignment as General Coverage adjustments affect Bandspread alignment.

The need for realignment of the H.F. oscillator of any band is indicated when the frequency calibration of the main tuning dial is in error by more than ± 5 divisions. To effect alignment the receiver controls are adjusted the same as outlined in Section 4-4 except that the Bandspread switch on each of the plug-in coils must be in the right-hand or Bandspread position.

The procedure in effecting Bandspread alignment is accomplished by adhering to the instructions given in the Bandspread Alignment Chart. The procedure is similar to that for General Coverage except for the method followed in checking tracking errors of the R.F. amplifier and mixer stages at the low-frequency limit of each coil set. To secure an indication of proper tracking, check the setting of the Bandspread trimmer capacitors C-3, C-16 and C-22 for the position of maximum receiver gain. Any change in capacity should decrease the receiver gain indicating proper tracking. The use of the trimmer capacitors C-3, C-16 and C-22 for tracking checks may destroy their proper settings, therefore they must be carefully rechecked at the high-frequency limit of the coil set. The location of the adjustments referred to in this section are shown on Figure Number 7. Each variable on the chart is followed by a number in parenthesis to identify its position on the respective coil set. Schematic diagrams of each of the four combination Bandspread and General Coverage coil sets A, B, C and D are furnished on Figure Number 11.

BANDSPREAD ALIGNMENT CHART

Step	Coil Set	Adjust Signal Source and Receiver to:	Adjust to Receive Test Signal	Adjust for Maximum Output
1	A	30.0 Mc.	Trimmer capacitor C-27 (Pos. 7).	Trimmer capacitors C-22 (Pos. 5), C-16 (Pos. 3), C-3 (Pos. 1).
2	A	27.2 Mc.	Padder capacitor C-25 (Pos. 15).	Padder capacitors C-20 (Pos. 14), C-14 (Pos. 12), C-1 (Pos. 10).
3	A	30.0 Mc.		Check step 1. Repeat steps 1 and 2 if necessary. Check step 1.
1	B	14.4 Mc.	Trimmer capacitor C-27 (Pos. 7).	Trimmer capacitors C-22 (Pos. 5), C-16 (Pos. 3), C-3 (Pos. 1).
2	B	14.0 Mc.	Padder capacitor C-25 (Pos. 15).	Padder capacitors C-20 (Pos. 14), C-14 (Pos. 12), C-1 (Pos. 10).
3	B	14.4 Mc.		Check step 1. Repeat steps 1 and 2 if necessary. Check step 1.
1	C	7.3 Mc.	Trimmer capacitor C-27 (Pos. 7).	Trimmer capacitors C-22 (Pos. 5), C-16 (Pos. 3), C-3 (Pos. 1).
2	C	7.0 Mc.	Padder capacitor C-25 (Pos. 15).	Padder capacitors C-20 (Pos. 14), C-14 (Pos. 12), C-1 (Pos. 10).
3	C	7.3 Mc.		Check step 1. Repeat steps 1 and 2 if necessary. Check step 1.
1	D	4.0 Mc.	Trimmer capacitor C-27 (Pos. 7).	Trimmer capacitors C-22 (Pos. 5), C-16 (Pos. 3), C-3 (Pos. 1).
2	D	3.5 Mc.	Padder capacitor C-25 (Pos. 15).	Padder capacitors C-20 (Pos. 14), C-14 (Pos. 12), C-1 (Pos. 10).
3	D	4.0 Mc.		Check step 1. Repeat steps 1 and 2 if necessary. Check step 1.

4-6. FIRST R.F. STAGE ALIGNMENT WITH LOW IMPEDANCE TRANSMISSION LINE

The tracking of the first R.F. amplifier stage on each of the coil ranges may be checked by rotating the Ant. Trim. control. If two definite peaks in output are observed while rotating the Ant. Trim. control, the first R.F. amplifier stage is tracking correctly and the setting at either peak is correct. The lack of a peak in output or the presence of only one peak indicates the stage is not tracking properly and correction should be made. The General Coverage adjustments affect the Bandspread adjustments and must therefore be performed first. The following procedure should be adhered to:

(a) GENERAL COVERAGE

(1) Set the Bandspread switch on each coil to the left-hand side or General Coverage position. Adjust the receiver for normal operation as follows: Control switch at A.M., Selectivity switch at Off, Ant. Trim. control pointer set in a vertical position with the arrow head towards the top of the receiver, A.F. Gain control set at 10 and the R.F. Gain control set to provide a suitable signal level.

(2) Connect the antenna feeders to the receiver antenna terminals and tune the receiver to the signal shown in step 1 on the General Coverage Alignment Chart for the coil set to be aligned. Adjust the trimmer capacitor C-2 for maximum signal output. Coil sets A and D do not use a first R.F. amplifier General Coverage trimmer but are peak tuned by the Ant. Trim. control over the full frequency range of each coil set.

(b) BANDSPREAD

(1) With the receiver adjusted in the same manner as for General Coverage shift the Bandspread switch on each coil terminal panel to the right-hand side or bandspread position.

(2) Connect the antenna feeders to the receiver antenna terminal and tune the receiver to the signal shown in Step 1 on the Bandspread Alignment Chart for the coil set being aligned. Adjust the Bandspread trimmer capacitor C-3 for maximum signal output. If no signal can be received the trimmer may be adjusted for maximum background noise.

4-7. S-METER ADJUSTMENT

The S-Meter balancing resistor R-21 is used to obtain a zero meter reading in the absence of signal input to the receiver. To make this adjustment set the controls as follows: Set the R.F. Gain control at 0, A.V.C. switch at A.V.C., Control switch at A.M. and the A.C. switch at On. Adjust the S-Meter balancing resistor R-21 for a zero reading on the S-Meter. This is a screwdriver type adjustment located on the top of the chassis.

SECTION 5. MAINTENANCE

5-1. GENERAL MAINTENANCE DATA

Any repairs in the HRO-60 receiver which necessitate resoldering of joints must be made with care. A good mechanical connection must be made before the solder is applied.

Failure of a vacuum tube in the receiver may reduce the sensitivity, produce intermittent operation or cause the equipment to be completely inoperative. In such cases, all tubes should be checked in an analyzer or similar tube testing equipment or by replacement with tubes of proven quality. When any tube is tested, it should be tapped or jarred to make sure that it has no internal loose connection or intermittent short circuit.

Tubes of the same type will vary slightly in their individual characteristics and this fact should be borne in mind when replacements become necessary. The C.W. oscillator, high-frequency oscillator and I.F. tubes should be chosen with care to select a replacement which most nearly approaches the characteristic of the original tube. A replacement high frequency oscillator tube can be readily checked by noting any change in dial calibration, particularly on the amateur bandspread bands. Substitution of new I.F. amplifier tubes may possibly alter overall gain and selectivity characteristics. The necessity for realignment as well as alignment procedures is discussed in Section 4.

In case of breakdown or failure of the receiver, the fault must first be localized. This can often be accomplished by observation of some peculiar action of one of the controls. Reference to the circuit diagram will aid in checking voltages at the various tube elements. Measurement of voltages in accordance with Section 5-4 will most likely indicate where failure has occurred.

5-2. CIRCUIT FAILURES

All component parts in the HRO-60 receiver have been selected to assure an ample factor of safety. Failure

may occur in individual cases and the most common cause of failure, excluding tubes, will probably be due to breakdown of a capacitor or resistor.

In the event of failure of the 4H-4C current regulator tube the receiver may be restored to operating condition by plugging a 6V6 tube into the 4H-4C socket. This device should be considered an emergency measure only since the current regulator tube is necessary to insure the excellent frequency stability of the HRO-60.

Bypass or filter capacitors which develop poor connections internally, or which become open-circuited, will cause decreased sensitivity, oscillation or poor stability. The defective unit can be located by temporarily connecting a good capacitor in parallel with each capacitor that is under suspicion.

Failure of any bypass or filter capacitor may seriously overload resistors in associated circuits. Overload of sufficient magnitude to permanently damage a resistor will cause the surface of the resistor to be scorched, making the defective unit easy to locate by visual inspection.

Open or short-circuited resistors can be definitely located by measuring the resistance of each individual resistor. The schematic diagram should be consulted to make sure that any particular resistor under test is not connected in parallel with some other circuit element which might produce a false measurement.

Loose connections which cause intermittent or noisy operation can often be found by tapping or shaking any component under suspicion with the receiver adjusted for normal operation.

5-3. STAGE GAIN MEASUREMENTS

The sensitivity measurements listed herein are made with the receiver set up as specified in Section 3-2 except that the A.F. Gain control is set at 10. Connect an output meter with an impedance to match the receiver output circuit i.e., 8 or 500 ohms to the output terminal panel in place of the loudspeaker. It is important that the proper output impedance match be observed.

Connect the high output lead of the signal generator through a 0.1 mf coupling capacitor to the grid of each tube as specified in the following table. The ground lead of the generator is connected to any convenient chassis point.

The signal generator, using 30% modulation, is varied between 453 and 457 kilocycles until a pronounced peak is obtained on the output meter.

With the generator attenuated to provide a one watt reading on the output meter the signal generator output should read within the limits specified on the following table:

<u>TERMINAL</u>	<u>TEST SIGNAL</u>
Mixer Grid	60 ± 10 Microvolts
First I.F. Grid	150 ± 20 Microvolts
Second I.F. Grid	1760 ± 200 Microvolts
Third I.F. Grid	40,000 ± 5000 Microvolts

NOTE

To obtain a gain measurement through the second conversion stage it will be necessary to release the conversion switch. Plugging in any but the D range coil used in the preceding measurements would result in readings which bear no relation to those already taken. In order to release the switch the receiver bottom plate must be removed. Remove the phillips head pivot screw in the center of the switch arm marked with an X in Figure 10 allowing the spring-loaded slide switch to move out to the double conversion position.

Return the generator connection to the mixer grid. Reset the generator to 1990 kc. and vary the frequency control between 1987 and 1993 until the peak is obtained on the output meter. Adjust the generator output to obtain 1 watt output across the 500-ohm terminals. The output of the signal generator should show a reading of 40 to 60 microvolts.

Replace the pivot screw making certain that it does not bind the switch arm. Remove and replace the coil set to determine that the switch is operating properly.

5-4. VOLTAGE TABULATION

All voltage measurements should be made using a high-impedance vacuum tube voltmeter. Readings taken with any other type of instrument will differ somewhat depending upon the input resistance of the meter. Voltmeter resistance should be ten times larger than the resistance of the circuit across which the voltage is measured otherwise the voltmeter will indicate a voltage lower than the actual voltage present. The tube socket voltage tabulations contained in Figure Number 8 were taken using a vacuum tube voltmeter with an input resistance of 11 megohms. All voltages are measured between specified socket terminals and chassis. The control settings to be observed are shown on Figure Number 8.

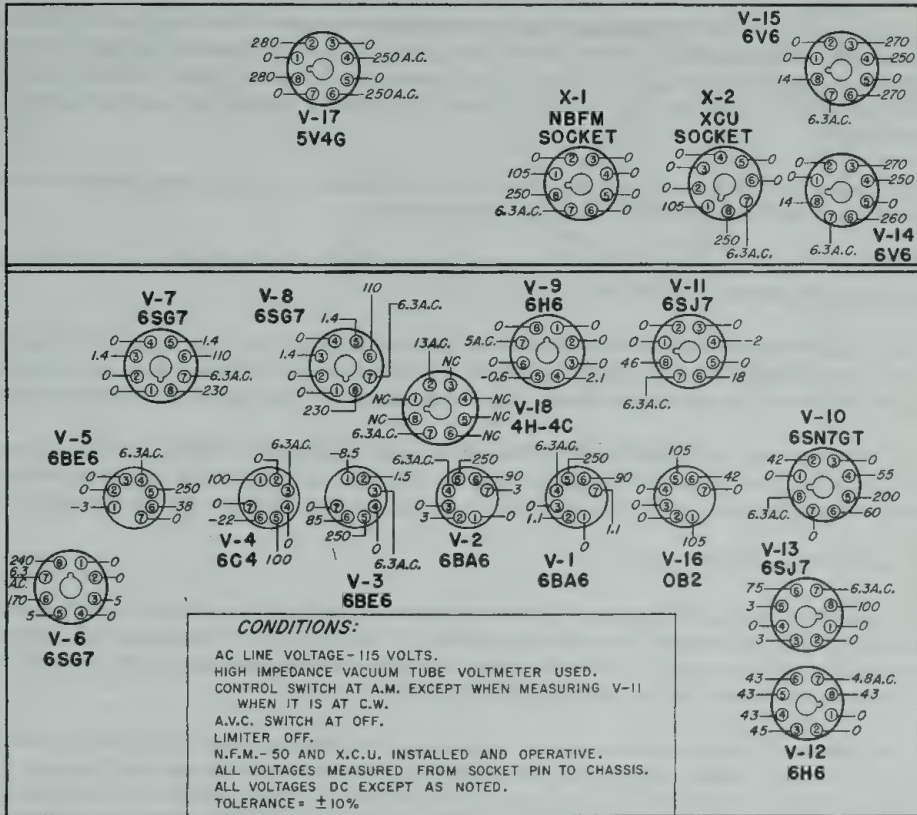

FRONT

Figure No. 8. Tube Socket Voltages

5-5. MAIN TUNING DIAL

The main tuning dial should normally give no trouble. If, however, the dial should become removed from the

receiver it must NOT be operated until mounted on the capacitor shaft WITH SET-SCREWS TIGHT. This is because the dial is only designed to rotate for ten revolutions (0 to 500) and if turned farther than this the mechanism will be damaged. When mounted on the capacitor, limit stops protect the dial. The procedure for re-mounting the dial is as follows:

- (a) Place the dial on the capacitor shaft, tighten set-screws and turn the dial counter-clockwise to fully mesh capacitor rotor plates so that the tips of the rotor plates are flush with the edges of the stator plates.
- (b) Loosen set-screws and rotate dial slowly until the dial reading has decreased to zero.
- (c) Tighten the set-screws.
- (d) Check position of rotor plates at zero. The tips of the rotor plates must be flush with the edge of the stator plates. A slight adjustment may be necessary and this is done by loosening the set-screws, adjusting the position of the dial and tightening the set-screws again.

If it is necessary to remove the dial at any future time, turn to 250 before removing the dial and do not disturb the setting of either the dial or capacitor until reassembled. If in doubt about the correct position, inspect the springs on the back of the dial. When the dial reads 250 these springs should be straight-up-and-down, they must not be tipped to one side.

It is important that the backplate and dial do not become separated. The back-plate is held in place by two springs so that its gear teeth mesh with the dial gear teeth in correct relationship for proper dial operation. If this backplate should be sprung out of place, it may return to an incorrect position and the proper dial numbers will not appear in the windows when the dial is used. To ascertain that the two parts are in correct position proceed as follows:

- (a) Locate small window near outer periphery of dial backplate and also locate dial number window on face of dial which is 180° removed from the small backplate window.
- (b) Hold dial so backplate lies flat in palm of left-hand and with right hand rotate dial knob until 250 appears in previously located dial window.
- (c) If dial is properly adjusted it will be noted that the pointer at the outer edge of the small window lines up with a marked tooth on the dial itself. It will be found that the dial and backplate can be moved so that the backplate pointer will mesh between teeth at points equidistant from marked tooth in either direction.
- (d) If by checking as in paragraph (c) the dial is found not properly adjusted, it will be necessary to separate the backplate from the dial far enough to bring the two gears out of mesh and then re-mesh the two parts until the proper setting is found. A number of trial settings may be required before the correct mesh is found.

5-6. SLIDE-RULE TUNING DIAL

The slide-rule tuning dial assembly has been adjusted at the factory for accurate synchronization with the micrometer dial. If not tampered with this mechanism will provide complete freedom of mechanical trouble over a long period of continuous use. It is driven by an anti-backlash tuning gear ganged with the main tuning dial. The slide-rule dial pointer is controlled by a string-drive assembly.

If replacement of the string-drive cord is required it will be necessary to remove the receiver chassis from its cabinet wraparound. Before removing the micrometer dial reference should be made to Paragraph 5 of this section for proper method of removal. Figure Number 9 illustrates the proper method of replacing the cord. After the cord has been replaced and before the receiver is returned to its cabinet the micrometer dial should temporarily be replaced (See Paragraph 5-5) and the slide-rule pointer correctly set in the following manner:

NOTE

This procedure may also be used if a check is desired to assure that the slide-rule dial pointer is properly syn-

chronized with that of the main tuning dial.

(a) Check the main tuning dial at zero on its dial scale. The tips of the rotor plates should be flush with the edge of the stator plates.

(b) Set the Band Selector control so that the D coil set scale appears.

(c) Set the main tuning dial at 490 on its dial scale. Correct setting of the slide-rule dial pointer is 4 megacycles on the dial scale. Draw the slide-rule pointer along the cord to its proper position being careful not to disturb the setting of the micrometer dial. After the correct setting has been obtained use a small amount of glyptol or household cement to fasten the dial pointer securely in place on the cord.

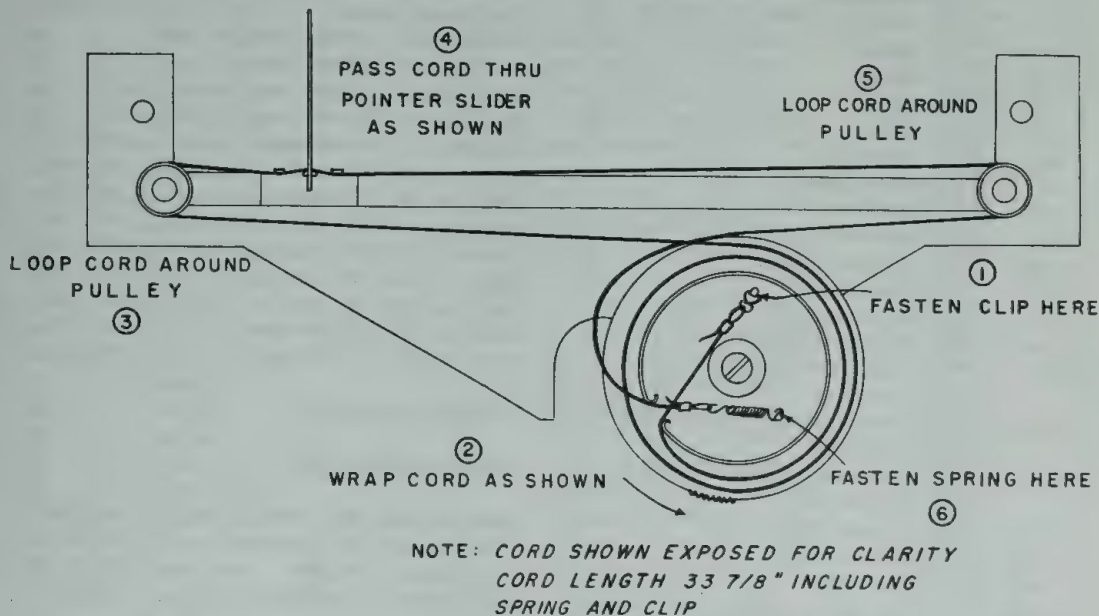

Figure No. 9. Instructions for Dial Cord Replacement

PARTS LIST

SYMBOL	FUNCTION	DESCRIPTION	DRAWING NO.
CAPACITORS			
C-1	T-1 bandsread padder used on A, B, C, D coil sets	Mica, variable, 3.5-35 mmf.	D832-2
C-2	T-1 general coverage trimmer used on B, C, F, H, J, AA, AB, AC, AD coil sets	Variable, air dielectric	
C-3	T-1 bandsread trimmer used on A, B, C, D coil sets	Variable, air dielectric	
C-4	Antenna trimmer	Variable, air dielectric	J957-32
C-5	Main tuning	Four section ganged	SB:2764
C-5A	V-1 tuning	Air dielectric, 225 mmf. max	
C-5B	V-2 tuning	Air dielectric, 225 mmf. max.	
C-5C	V-3 tuning	Air dielectric, 225 mmf. max.	
C-5D	V-4 tuning	Air dielectric, 225 mmf. max.	
C-6	V-1 grid filter	Ceramic, .01 mfd. 400 vdcw	K946-2
C-7	V-1 screen bypass	Paper, .05 mfd. 400 vdcw	L217-29
C-8	V-1 grid filter	Mica, .01 mfd. 300 vdcw	J666-56
C-9	V-1 cathode bypass	Paper, .05 mfd. 400 vdcw	L217-29
C-10	V-1 screen bypass	Ceramic, .005 mfd. 450 vdcw	K946-1
C-11	V-1 plate filter	Paper, .1 mfd. 400 vdcw	L217-35
C-12	V-2 screen bypass	Paper, .05 mfd. 400 vdcw	L217-29
C-13	V-2 grid return bypass	Ceramic, .005 mfd. 450 vdcw	K946-1
C-14	T-2 bandsread padder used on A, B, C, D coil sets	Mica, variable, 3.5-35 mmf.	D832-2
C-15	T-2 general coverage trimmer used on all coil sets	Variable, air dielectric	
C-16	T-2 bandsread trimmer used on A, B, C, D coil sets	Variable, air dielectric	
C-17	V-2 cathode bypass	Paper, .05 mfd. 400 vdcw	L217-29
C-18	V-2 screen bypass	Ceramic, .005 mfd. 450 vdcw	K946-1
C-19	V-2 plate filter	Paper, .1 mfd. 400 vdcw	L217-35
C-20	T-3 bandsread padder used on A, B, C, D coil sets	Mica, variable, 3.5-35 mmf.	D832-2
C-21	T-3 general coverage trimmer used on all coil sets	Variable, air dielectric	
C-22	T-3 bandsread trimmer used on A, B, C, D coil sets	Variable, air dielectric	
C-23	V-3 cathode bypass	Ceramic, .01 mfd. 450 vdcw	K946-2
C-24	V-3 screen bypass	Ceramic, .01 mfd. 450 vdcw	K946-2
C-25	T-4 bandsread padder used on A, B, C, D coil sets	Variable, air dielectric	
C-26	T-4 general coverage trimmer used on all coil sets	Variable, air dielectric	
C-27	T-4 bandsread trimmer used on A, B, C, D coil sets	Variable, air dielectric	
C-28	T-4 general coverage padder:		
	A coil set	Mica, 680 mmf. 300 vdcw	R035-1
	B coil set	Mica, 910 mmf. 500 vdcw	R035-2
	C coil set	Mica, 1600 mmf. 500 vdcw	J666-21
	D coil set	Mica, 900 mmf. 500 vdcw	J666-62
	E coil set	Mica, 470 mmf. 500 vdcw	H500-18
	F coil set	Mica, 330 mmf. 500 vdcw	H500-22

PARTS LIST (CONT'D)

SYMBOL	FUNCTION	DESCRIPTION	DRAWING NO.
CAPACITORS (CONT'D)			
	G coil set	Ceramic, 100 mmf. 500 vdcw	D825C-304
	J coil set	Ceramic, 50 mmf. 500 vdcw	D825D-417
	AA coil set	Ceramic, 10 mmf. 500 vdcw	D825D-402
	AB coil set	Ceramic, 100 mmf. 500 vdcw	D825C-303
	AD coil set	Ceramic, 10 mmf. 500 vdcw	D825D-402
C-29	Oscillator trimmer	Variable, air dielectric	J957-33
C-30	V-4 grid coupling	Ceramic, 100 mmf. 500 vdcw	D825C-304
C-31	V-2 plate filter	Ceramic, .005 mf. 450 vdcw	K946-1
C-32	V-3 plate filter	Ceramic, .01 mf. 450 vdcw	K946-2
C-33	T-5 primary trimmer	Mica, 270 mmf. 500 vdcw	H500-6
C-34	Bridge balancing	Ceramic, 39 mmf. 500 vdcw	D825D-455
C-35	Bridge balancing	Ceramic, 75 mmf. 500 vdcw	D825C-301
C-36	Phase balance adjustment	Mica, variable, 3.5-35 mmf.	D832-2
C-37	Phasing control	Variable, air dielectric	SA:9190
C-38	Selectivity compensator	Mica, variable, 3.5-35 mmf.	D832-2
C-39	T-5 output adjustment	Mica, 100 mmf. 500 vdcw	H500-4
C-40	Selectivity adjusting	Ceramic, 10 mmf. 500 vdcw	D825D-426
C-41	Selectivity adjusting	Ceramic, 25 mmf. 500 vdcw	D825D-411
C-42	Selectivity adjusting	Ceramic, 25 mmf. 500 vdcw	D825D-411
C-43	V-6 A.V.C. filter	Ceramic, .001 mfd. 300 vdcw	K375-4
C-44	T-9 tuning	Mica, 510 mmf. 500 vdcw	H500-5
C-45	L-2 tuning	Mica, 510 mmf. 500 vdcw	H500-5
C-46	L-3 tuning	Mica, 510 mmf. 500 vdcw	H500-5
C-47	L-4 tuning	Mica, 510 mmf. 500 vdcw	H500-5
C-48	L-5 tuning	Mica, 510 mmf. 500 vdcw	H500-5
C-49	V-7 A.V.C. filter	Ceramic, .001 mfd. 300 vdcw	K375-4
C-50	V-7 cathode bypass	Ceramic, .01 mfd. 450 vdcw	K946-2
C-51	V-7 screen bypass	Ceramic, .01 mfd. 450 vdcw	K946-2
C-52	V-7 plate filter	Ceramic, .01 mfd. 450 vdcw	K946-2
C-53	V-6 cathode bypass	Paper, .1 mfd. 400 vdcw	L217-35
C-54	V-9 coupling	Ceramic, .0001 mfd. 500 vdcw	D825D-421
C-55	V-10A grid	Ceramic, .01 mfd. 450 vdcw	K946-2
C-56	V-6 screen	Ceramic, .01 mfd. 450 vdcw	K946-2
C-57	V-9 plate	Ceramic, 270 mmf. 500 vdcw	J633-2
C-58	V-4 to V-3 coupling	Mica, .01 mfd. 500 vdcw	J666-56
C-59	V-4 plate filter	Paper, .1 mfd. 400 vdcw	L217-35
C-60	V-3 plate filter	Ceramic, .01 mfd. 450 vdcw	K946-2
C-61	L-18 tuning	Mica, 510 mmf. 500 vdcw	H500-5
C-62	L-19 tuning	Mica, 510 mmf. 500 vdcw	H500-5
C-63	A.C. line bypass	Mica, .0022 mfd. 1000 vdcw	J667-66
C-64	A.C. line bypass	Mica, .0022 mfd. 1000 vdcw	J667-66
C-65	Power supply filter	Electrolytic, 40 + 40 mfd. 475 vdcw	K945-3
C-65A	Power supply input filter	Part of C-65	
C-65B	Power supply output filter	Part of C-65	
C-66	V-9 to V-12 coupling	Ceramic, .01 mfd. 450 vdcw	K946-2
C-67	V-12 threshold filter	Paper, .1 mfd. 400 vdcw	L217-35
C-68	V-12 plate filter	Paper, .1 mfd. 400 vdcw	L217-35
C-69	V-12 to X-3 coupling	Ceramic, .01 mfd. 450 vdcw	K946-2
C-70	V-13 tone compensator	Electrolytic, 25 mfd. 50 vdcw	E338-4
C-71	V-13 cathode bypass	Paper, .5 mfd. 200 vdcw	L217-47
C-72	V-13 screen bypass	Paper, .1 mfd. 400 vdcw	L217-35
C-73	V-13 plate filter	Paper, .1 mfd. 400 vdcw	L217-35

PARTS LIST (CONT'D)

SYMBOL	FUNCTION	DESCRIPTION	DRAWING NO.
CAPACITORS (CONT'D)			
C-74	Tone	Paper, .01 mfd. 600 vdcw	L217-16
C-75	V-10B to V-13 coupling	Paper, .01 mfd. 600 vdcw	L217-16
C-76	V-10B grid	Ceramic, .0001 mfd. 500 vdcw	D825D-421
C-77	V-10B to V-14 coupling	Paper, .01 mfd. 600 vdcw	L217-16
C-78	V-10B to V-15 coupling	Paper, .01 mfd. 600 vdcw	L217-16
C-79	V-14 and V-15 cathode bypass	Electrolytic, 25 mfd. 50 vdcw	E338-4
C-80	T-12 tone compensating	Mica, .0024 mfd. 1,000 vdcw	J667-68
C-81	Temperature drift compensator	Ceramic, 5 mmf, 500 vdcw	D825D-401
C-82	T-1 fixed bandsread padder:	Ceramic	
	A coil set	10 mmf. 500 vdcw	D825D-402
	B coil set	5 mmf. 500 vdcw	D825D-401
	C coil set	10 mmf. 500 vdcw	D825D-402
	D coil set	25 mmf. 500 vdcw	D825D-411
C-83	T-2 fixed bandsread padder:	Ceramic	
	A coil set	10 mmf. 500 vdcw	D825D-402
	B coil set	5 mmf. 500 vdcw	D825D-401
	C coil set	10 mmf. 500 vdcw	D825D-402
	D coil set	25 mmf. 500 vdcw	D825D-411
C-84	T-3 fixed bandsread padder:	Ceramic	
	A coil set	10 mmf. 500 vdcw	D825D-402
	B coil set	5 mmf. 500 vdcw	D825D-401
	C coil set	10 mmf. 500 vdcw	D825D-402
	D coil set	25 mmf. 500 vdcw	D825D-411
C-85	T-4 bs padder used on A coil set	Ceramic, 10 mmf. 500 vdcw	D825D-454
	B coil set	Ceramic, 5 mmf. 500 vdcw	D825D-440
C-86	T-4 fixed divider used on D coil set	Ceramic, 21 mmf. 500 vdcw	D825D-410
C-87	T-4 fixed general coverage trimmer:		
	A coil set	Ceramic, 50 mmf. 500 vdcw	D825D-453
	B coil set	Ceramic, 5 mmf. 500 vdcw	D825D-440
	AA coil set	Ceramic, 10 mmf. 500 vdcw	D825D-402
	AB coil set	Ceramic, 35 mmf. 500 vdcw	D825D-413
	AC coil set	Ceramic, 68 mmf. 500 vdcw	D825C-343
	AD coil set	Mica, 56 mmf. 500 vdcw	H500-23
C-88	T-1 fixed general coverage padder:		
	A coil set	Mica, 1200 mmf. 500 vdcw	J666-16
	AB coil set	Ceramic, 120 mmf. 500 vdcw	D825C-305
C-89	T-4 fixed temperature compensator used on A coil set	Ceramic, 10 mmf. 500 vdcw	D825D-437
C-90	T-2 primary trimmer used on H coil set	Ceramic, 21 mmf. 500 vdcw	D825D-410
C-91	T-1 general coverage trimmer:	Ceramic	
	AA coil set	5 mmf. 500 vdcw	D825D-401
	AB coil set	21 mmf. 500 vdcw	D825D-410
	AC coil set	50 mmf. 500 vdcw	D825D-417
C-92	T-2 coupling used on AB coil set	Mica, 470 mmf. 500 vdcw	J665-56
C-93	T-2 general coverage padder used on AB coil set	Ceramic, 100 mmf. 500 vdcw	D825C-304
C-94	T-3 coupling used on AB coil set	Mica, 470 mmf. 500 vdcw	J665-56
C-95	T-3 general coverage trimmer:	Ceramic	
	AB coil set	10 mmf. 500 vdcw	D825D-402
	AC coil set	68 mmf. 500 vdcw	D825C-343
C-96	V-2 cathode bypass	Ceramic, .005 mfd. 450 vdcw	K946-1

PARTS LIST (CONT'D)

SYMBOL	FUNCTION	DESCRIPTION	DRAWING NO.
CAPACITORS (CONT'D)			
C-97	T-1 general coverage padder used on AA, AB, AC, AD coil sets	Variable, air dielectric	
C-98	T-2 general coverage padder used on AA, AB, AD coil sets	Variable, air dielectric	
C-99	T-3 general coverage padder used on AA, AB, AC, AD coil sets	Variable, air dielectric	
C-100	T-4 general coverage padder used on E, F, G, H, J, AA, AB, AC, AD coil sets	Variable, air dielectric	
C-101	T-3 G.C. padder used on AB coil set	Ceramic, 100 mmf. 500 vdcw	D825C-304
C-102	T-2 general coverage trimmer: AB coil set	Ceramic 10 mmf. 500 vdcw	D825D-402
	AC coil set	68 mmf. 500 vdcw	D825C-343
C-103	V-8 coupling X-1	Ceramic, 10 mmf. 500 vdcw	D825D-437
C-104	T-9 tuning	Mica, 510 mmf. 500 vdcw	H500-5
C-105	V-5 grid	Ceramic, .0001 mfd. 500 vdcw	D825C-304
C-106	L-8 tuning	Mica, 510 mmf. 500 vdcw	H500-5
C-107	L-9 tuning	Mica, 510 mmf. 500 vdcw	H500-5
C-108	V-8 A.V.C. filter	Ceramic, .001 mfd. 300 vdcw	K375-4
C-109	V-8 cathode bypass	Ceramic, .01 mfd. 450 vdcw	K946-2
C-110	R.F. filter	Paper, .25 mfd. 200 vdcw	L217-48
C-111	V-8 screen	Ceramic, .01 mfd. 450 vdcw	K946-2
C-112	V-8 plate filter	Ceramic, .01 mfd. 450 vdcw	K946-2
C-113	L-10 tuning	Mica, 510 mmf. 500 vdcw	H500-5
C-114	L-11 tuning	Mica, 510 mmf. 500 vdcw	H500-5
C-115	V-5 screen bypass	Ceramic, .01 mfd. 450 vdcw	K946-2
C-116	L-16 tuning	Mica, 270 mmf. 500 vdcw	H500-6
C-117	V-11 grid	Mica, 270 mmf. 500 vdcw	J665-47
C-118	V-17 plate filter	Paper, .1 mfd. 600 vdcw	L217-36
C-119	H.F. oscillator padder	Ceramic, 10 mmf. 500 vdcw	D825D-402
C-120	L-6 tuning	Mica, 510 mmf. 500 vdcw	H500-5
C-121	L-7 tuning	Mica, 510 mmf. 500 vdcw	H500-5
C-122	C.W.O. control	Variable, air dielectric	J957-32
C-123	V-11 screen bypass	Ceramic, .01 mfd. 450 vdcw	K946-2
C-124	V-6 plate filter	Ceramic, .01 mfd. 450 vdcw	K946-2
C-125	V-9 to V-11 coupling	Ceramic, 3 mmf. 500 vdcw	J695-4
C-126	Y-1 to V-6 coupling	Ceramic, 3 mmf. 500 vdcw	D825D-449
C-127	T-1, T-2 grid return on AD coil set	Mica, 1000 mmf. 300 vdcw	J665-71
C-128	D.C. bypass	Ceramic, .01 mfd. 450 vdcw	K946-2
C-129	External B+ switch bypass	Ceramic, .005 mfd. 450 vdcw	K946-1
C-130	External B+ switch bypass	Ceramic, .005 mfd. 450 vdcw	K946-1
C-131	External B+ switch bypass	Ceramic, .005 mfd. 450 vdcw	K946-1
C-132	Speaker output filter	Ceramic, .005 mfd. 450 vdcw	K946-1
C-133	Osc fil bypass	Ceramic, .005 mfd. 450 vdcw	K946-1
C-134	T-4 bandsread padder, C coil set	Ceramic, 10 mmf. 500 vdcw	D825D-419
C-135	V-5 plate	Ceramic, 5 mmf. 500 vdcw	D825D-401
RESISTORS			
R-1	V-1 grid filter	Fixed, 470,000 ohms, 1/2 W	J569-57
R-2	V-1 cathode	Fixed, 100 ohms, 1/2 W	J569-13
R-3	V-1 screen	Fixed, 47,000 ohms, 1/2 W	J569-45
R-4	V-2 grid	Fixed, 470,000 ohms, 1/2 W	J569-57
R-5	V-2 cathode	Fixed, 560 ohms, 1/2 W	J569-22
R-6	R.F. gain control	Variable, W.W. 5,000 ohms, 3 W	K349-4
R-7	V-3 injector grid	Fixed, 22,000 ohms, 1/2 W	J569-41

PARTS LIST (CONT'D)

SYMBOL	FUNCTION	DESCRIPTION	DRAWING NO.
RESISTORS (CONT'D)			
R-8	V-3 cathode	Fixed, 220 ohms, 1/2 W	J569-17
R-9	V-3 screen	Fixed, 33,000 ohms, 1 W	J571-43
R-10	V-4 grid	Fixed, 22,000 ohms, 1/2 W	J569-41
R-11	Voltage divider	Fixed, 100,000 ohms, 1 W	J571-49
R-12	V-6 grid	Fixed, 470,000 ohms, 1/2 W	J569-57
R-13	V-2 screen dropping	Fixed, 100,000 ohms, 1/2 W	J569-49
R-14	Voltage divider	Fixed, 2,200 ohms, 1/2 W	J569-29
R-15	Selectivity balancing	Fixed, 470 ohms, 1/2 W	J569-21
R-16	V-6 cathode	Fixed, 1/2 W. individually chosen to meet the requirements of each receiver	
R-17	V-6 screen	Fixed, 47,000 ohms, 1/2 W	J569-45
R-18	V-7 grid filter	Fixed, 470,000 ohms, 1/2 W	J569-57
R-19	V-7 cathode	Fixed, 330 ohms, 1/2 W	J569-19
R-20	V-6 plate filter	Fixed, 2,200 ohms, 1/2 W	J569-29
R-21	S meter zero adjustment	Variable, 1,000 ohms, 1 W	D831-2
R-22	V-9 plate load	Fixed, 1.5 meg. 1/2 W	J569-63
R-23	A.V.C. filter	Fixed, 1.5 meg. 1/2 W	J569-63
R-24	V-7 plate filter	Fixed, 2,200 ohms, 1/2 W	J569-29
R-25	V-4 plate filter	Fixed, 2,200 ohms, 1/2 W	J569-29
R-26	V-16 dropping	Fixed, 5,000 ohms, 10 W	E959-10
R-27	V-5 screen	Fixed, 100,000 ohms, 1/2 W	J569-49
R-28	V-3 plate filter	Fixed, 10,000 ohms, 1/2 W	J569-37
R-29	V-9 filament dropping	Fixed W.W. 4.3 ohms, 1 W	K098-48
R-30	V-5 grid	Fixed, 22,000 ohms, 1/2 W	J569-41
R-31	V-5 isolating	Fixed, 100 ohms, 1/2 W	J569-13
R-32	V-11 grid	Fixed, 22,000 ohms, 1/2 W	J569-41
R-33	V-9 plate load	Fixed, 470,000 ohms, 1/2 W	J569-57
R-34	V-12 plate	Fixed, 220,000 ohms, 1/2 W	J569-53
R-35	V-12 cathode	Fixed, 220,000 ohms, 1/2 W	J569-53
R-36	Limiter threshold control	Variable, 500,000 ohms	J681-2
R-37	Limiter threshold filter	Fixed, 220,000 ohms, 1/2 W	J569-53
R-38	V-12 plate filter	Fixed, 820,000 ohms, 1/2 W	J569-60
R-39	V-12 plate load	Fixed, 470,000 ohms, 1/2 W	J569-57
R-40	A.F. gain control	Variable, 500,000 ohms	K347-7
R-41	Limiter output divider	Fixed, 220,000 ohms, 1/2 W	J569-53
R-42	V-13 cathode	Fixed, 2,200 ohms, 1/2 W	J569-29
R-43	V-13 cathode divider	Fixed, 150 ohms, 1/2 W	J569-15
R-44	Degeneration feedback	Fixed, 6800 ohms, 1/2 W	J569-35
R-45	V-13 screen filter	Fixed, 470,000 ohms, 1/2 W	J569-57
R-46	V-13 plate load	Fixed, 100,000 ohms, 1/2 W	J569-49
R-47	V-13 plate filter	Fixed, 47,000 ohms, 1/2 W	J569-45
R-48	Tone control	Variable, 500,000 ohms	K347-7
R-49	V-10B grid	Fixed, 220,000 ohms, 1/2 W	J569-53
R-50	V-10B cathode	Fixed, 4,700 ohms, 1/2 W	J569-33
R-51	V-10B cathode load	Fixed, 47,000 ohms, 1/2 W	J569-45
R-52	V-10B plate load	Fixed, 47,000 ohms, 1/2 W	J569-45
R-53	V-13 grid	Fixed, 220,000 ohms, 1/2 W	J569-53
R-54	V-14 grid	Fixed, 220,000 ohms, 1/2 W	J569-53
R-55	V-14 and V-15 cathode bias	Fixed, 180 ohms, 2 W	J572-16
R-56	Output load	Fixed, 470 ohms, 2 W	J572-21

PARTS LIST (CONT'D)

SYMBOL	FUNCTION	DESCRIPTION	DRAWING NO.
RESISTORS (CONT'D)			
R-57	T-1 antenna load used on A coil set	Fixed, 22 ohms, 1/2 W	J569-5
R-58	V-7 screen dropping	Fixed, 47,000 ohms, 1/2 W	J569-45
R-59	V-8 A.V.C. filter	Fixed, 470,000 ohms, 1/2 W	J569-57
R-60	V-8 cathode	Fixed, 150 ohms, 1/2 W	J569-15
R-61	V-8 screen dropping	Fixed, 47,000 ohms, 1/2 W	J569-45
R-62	V-8 plate filter	Fixed, 2,200 ohms, 1/2 W	J569-29
R-63	V-11 screen bleeder	Fixed, 100,000 ohms, 1/2 W	J569-49
R-64	V-10A plate load	Fixed, 39,000 ohms, 1/2 W	J569-44
R-65	V-11 screen filter	Fixed, 100,000 ohms, 1/2 W	J569-49
R-66	V-10A cathode	Fixed, 1000 ohms, 1/2 W	J569-25
R-67	V-12 plate load	Fixed, 220,000 ohms, 1/2 W	J569-53
R-68	V-9 cathode	Fixed, 33 ohms, 1/2 W	J569-7
R-69	V-11 plate	Fixed, 220,000 ohms, 1/2 W	J569-53
R-70	Dimmer control	Variable, W.W. 25 ohms	K915-13
R-71	V-4 plate equalizing	Fixed, 22 ohms, 1/2 W	J569-5
R-72	V-12 filament dropping	Fixed, W.W. 4.3 ohms, 1 W	K098-48
MISCELLANEOUS			
E-1	Antenna input terminal	Screw type, three terminals	E261-3
E-2	B+ switch terminal	Screw type, three terminals	E261-7
E-3	Audio output terminal	Screw type, three terminals	E259-2
F-1	Fuse 3AG	2 amps at 125 v	F135-19
I-1	Dial lamp	No. 47	F136-6
I-2	Dial lamp	No. 47	F136-6
I-3	S meter lamp	No. 47	F136-6
J-1	Phono jack	Single circuit	J993-1
J-2	Phono jack	Multi-circuit	F316-1
L-1	Filter choke	17 henries	S669-1
L-2	T-6 tuning	Variable iron core inductor	SA:3905
L-3	T-6 tuning	Variable iron-core inductor	SA:3366
L-4	T-6 tuning	Variable iron-core inductor	SA:3905
L-5	T-6 tuning	Variable iron-core inductor	SA:3366
L-6	T-7 tuning	Variable iron-core inductor	SA:3905
L-7	T-7 tuning	Variable iron-core inductor	SA:3366
L-8	T-7 tuning	Variable iron-core inductor	SA:3905
L-9	T-7 tuning	Variable iron-core inductor	SA:3366
L-10	T-8 tuning	Variable iron-core inductor	SA:3905
L-11	T-8 tuning	Variable iron-core inductor	SA:3366
L-12	T-5 input tuning	Variable iron-core inductor	SA:9202
L-13	T-5 output tuning	Variable iron-core inductor	SA:9201
L-14	T-6 coupling	R.F. choke, 1.1 microhenries	SA:6072
L-15	T-7 coupling	R.F. choke, 1.1 microhenries	SA:6072
L-16	T-11 tuning	Variable iron-core inductor	SA:3419
L-17	T-9 tuning	1555 kc.	SA:9204
L-18	T-10 tuning	2010 kc.	SA:9206
L-19	T-10 tuning	Part of L-18	
L-20	Speaker output choke	1 microhenry	SA:3992
L-21	External B+ filter	1 microhenry	SA:3992
L-22	External B+ filter	1 microhenry	SA:3992
L-23	External B+ filter	1 microhenry	SA:3992
M-1	S meter	0-1 ma. W/S scale	J984-5
P-1	Select-object plug	Octal	SA:6569
P-2	A.C. jumper plug	Octal	SA:3731
S-1	T-1 B.S.-G.C. switch	Twist type, two position	SA:6749

PARTS LIST (CONT'D)

SYMBOL	FUNCTION	DESCRIPTION	DRAWING NO.
MISCELLANEOUS (CONT'D)			
S-2	T-2 B.S. - G.C. switch	Twist type, two position	SA:6749
S-3	T-3 B.S. - G.C. switch	Twist type, two position	SA:6749
S-4	T-4 B.S. - G.C. switch	Twist type, two position	SA:6749
S-5	Selectivity switch	Six position, double pole	E195-1
S-6	A.V.C. On-Off switch	SPST, bat handle, toggle	E230-2
S-7	Control switch	Double-wafer, four-position	Q002-1
S-8	Crystal calibrate switch	Center position open	P738-1
S-9	A.C. switch	Part of R-40	
S-10	T-13 primary selector switch	DPDT toggle	H340-4
S-11	B+ switch	SPST toggle	E230-2
S-12	Limiter switch	Part of R-36	
S-13	Tone switch	Part of R-48	
S-14	2nd. conversion switch	Sliding type	R027-1
T-1	First R.F. amplifier transformer		
	A band	14.0 - 30 mc.	SA:6654
	B band	7.0 - 14.4 mc.	SA:6755
	C band	3.5 - 7.3 mc.	SA:6759
	D band	1.7 - 4.0 mc.	SA:6635
	E band	900 - 2050 kc.	SA:6513
	F band	480 - 960 kc.	SA:6660
	G band	180 - 420 kc.	SA:6665
	H band	100 - 200 kc.	SA:6803
	J band	50 - 100 kc.	SA:6808
	AA band	27 - 30 mc.	SA:6814
	AB band	25 - 35 mc.	SA:6675
	AC band	21 - 21.5 mc.	SA:8073
	AD band	50 - 54 mc.	SA:9261
T-2	Second R.F. amplifier transformer		
	A band	14 - 30 mc.	SA:6751
	B band	7 - 14.4 mc.	SA:9258
	C band	3.5 - 7.3 mc.	SA:6641
	D band	1.7 - 4 mc.	SA:6637
	E band	900 - 2050 kc.	SA:6540
	F band	480 - 960 kc.	SA:6662
	G band	180 - 430 kc.	SA:6667
	H band	100 - 200 kc.	SA:6669
	J band	50 - 100 kc.	SA:6809
	AA band	27 - 30 mc.	SA:9247
	AB band	25 - 35 mc.	SA:6818
	AC band	21 - 21.5 mc.	SA:8074
	AD band	50 - 54 mc.	SA:9262
T-3	Mixer transformer		
	A band	14 - 30 mc.	SA:6752
	B band	7 - 14.4 mc.	SA:9259
	C band	3.5 - 7.3 mc.	SA:6642
	D band	1.7 - 4 mc.	SA:6638
	E band	900 - 2050 kc.	SA:6789
	F band	480 - 960 kc.	SA:6794
	G band	180 - 430 kc.	SA:6800
	H band	100 - 200 kc.	SA:6804
	J band	50 - 100 kc.	SA:6810
	AA band	27 - 30 mc.	SA:9248

PARTS LIST (CONT'D)

SYMBOL	FUNCTION	DESCRIPTION	DRAWING NO.
MISCELLANEOUS (CONT'D)			
T-3	Cont'd AB band AC band AD band	25 - 35 mc. 21 - 21.5 mc. 50 - 54 mc.	SA:6676 SA:8075 SA:9266
T-4	H.F. oscillator transformer A band B band C band D band E band F band G band H band J band AA band AB band AC band AD band	14 - 30 mc. 7 - 14.4 mc. 3.5 - 7.3 mc. 1.7 - 4 mc. 900 - 2050 kc. 400 - 960 kc. 180 - 430 kc. 100 - 200 kc. 50 - 100 kc. 27 - 30 mc. 25 - 35 mc. 21 - 21.5 mc. 50 - 54 mc.	SA:9254 SA:9260 SA:6760 SA:6776 SA:6631 SA:6795 SA:6785 SA:6805 SA:6811 SA:9249 SA:9265 SA:9268 SA:9267 SA:9195
T-5	Crystal filter		SA:8448
T-6	2nd. I.F. transformer	455 kc.	SA:8448
T-7	3rd. I.F. transformer	455 kc.	SA:3363
T-8	Detector input transformer	455 kc.	SA:9203
T-9	Oscillator transformer	1555 kc.	SA:9205
T-10	I.F. transformer	1990 kc.	SA:9193
T-11	C.W.O. transformer	455 kc.	P187-1
T-12	Audio output transformer	Pri. 10,000 ohms Sec. 8/600 ohms 10 watts	
T-13	Power transformer	Primary: term. 4 and 5, 115 volts term. 4 and 7, 230 volts Secondary: term. 2, 1 and 3, 6.3-0-7 volts Secondary: term. 11 and 12, 5 volts Secondary: term. 8, 10 and 9, 275-0- 275 V. Secondary: term. 2 electrostatic shield	S515-1
V-1	First R.F. amplifier	6BA6	
V-2	Second R.F. amplifier	6BA6	
V-3	Mixer	6BE6	
V-4	H.F. oscillator	6C4	
V-5	Second converter	6BE6	
V-6	First I.F. amplifier	6SG7	
V-7	Second I.F. amplifier	6SG7	
V-8	Third I.F. amplifier	6SG7	
V-9	Second detector and A.V.C.	6H6	
V-10	Phase inverter - S meter amplifier	6SN7GT	
V-11	C.W. oscillator	6SJ7	
V-12	Noise limiter	6H6	
V-13	Audio amplifier	6SJ7	
V-14	Audio output	6V6GT	
V-15	Audio output	6V6GT	
V-16	Voltage regulator	OB2	
V-17	Rectifier	5V4G	

PARTS LIST (CONT'D)

SYMBOL	FUNCTION	DESCRIPTION	DRAWING NO.
MISCELLANEOUS (CONT'D)			
V-18	Current regulator	4H4C	
X-1	N.B.F.M. socket	Octal	J625-2
X-2	Crystal calibrator socket	Octal	J625-2
X-3	Select-o-ject socket	Octal	J625-2
X-4	Battery socket	Octal	J625-2
Y-1	Crystal resonator	455 kc.	E979-1
MECHANICAL PARTS		MECHANICAL PARTS (CONT'D)	
DESCRIPTION	NAT. CO. TYPE	DESCRIPTION	NAT. CO. TYPE
Knob for antenna trimmer	SA:7021	Shield for BSW terminal	K445-1
Knob for tone adjusting	SA:7021	Bakelite slide for guiding coil sets (2)	D393-3
Knob for dial light dimmer	SA:7021	Fuse extractor post	E510-1
Knob for crystal phasing	SA:6868	Coil set pull levers (2)	SA:7001
Knob for C.W.O. adjusting	SA:6868	Drum dial assembly	SA:9246
Knob for selectivity switch	SA:6869	Drum (no scales included)	SA:7922
Knob for limiter switch	SA:6870	Gear pulley	SA:6595
Knob for A.F. gain	SA:6871	Spring (2)	P216-1
Knob for R.F. gain	SA:6867	Bearing washer	M953-2
Knob for control switch	SA:6587	Spring washer	J728-7
Knob for main tuning	SA:6586	Drum turning shaft	P221-2
Spring washer for grounding main tuning knob	L087-1	'O' ring	L792-3
Main tuning capacitor (complete assembly)	SB:2764	Snap ring	L936-1
Brush boards (4)	SA:6575	Dial cord	SA:6596
Shaft for control switch	D644-2	Spring for dial cord	P223-1
Coupling for control switch	SA:22	Drum stop	P472-1
Shaft for C.W.O. control	Q534-2	Stop spring	P471-1
Coupling for C.W.O. control shaft	SA:22	Dial support plate	SA:8945
Bracket for mounting C.W.O. capacitor	R028-1	Pulley	P217-1
Shaft extension for phasing control	C696-4	Dial pointer	P191-1
Coupling for phasing control shaft	D694-2	Pointer rail	M949-1
Bracket for mounting conversion switch	R029-1	Dial light socket (2)	J721-4
Lever for actuating conversion switch	R030-1	Dial scale for Band A	P136-15
Spring for conversion switch	R032-1	Dial scale for Band B	P136-16
Socket assembly for S meter lamp	K377-4	Dial scale for Band C	P136-3
Socket for miniature tubes (6)	SA:4916	Dial scale for Band D	P136-4
Fibre washers for mounting miniature tube sockets (12)	H285-10	Dial scale for Band A (bandspread only)	P136-17
Shield for miniature tubes (5)	SA:3387	Dial scale for Band B (bandspread only)	P136-18
Shield base for miniature tubes (5)	SA:3847	Dial scale for Band C (bandspread only)	P136-7
Octal tube sockets (16)	J625-2	Dial scale for Band D (bandspread only)	P136-8
Spring clamp for type OB2 tube	SB:1292	Dial scale for Band E-F	P136-9
A.C. line cord	E544-2	Dial scale for Band G-H	P136-10
Lock for A.C. line cord	R025-2	Dial scale for Band J	P136-11
		Dial scale for Band AA	P136-19
		Dial scale for Band AB	P136-20

PARTS LIST (CONT'D)

DESCRIPTION	NAT. CO. TYPE
MECHANICAL PARTS (CONT'D)	
Dial scale for Band AC	P136-14
Dial scale for Band AD	P136-21
MECHANICAL PARTS USED ON TABLE MODEL ONLY	
Chassis mounting angle bracket (left)	P244-1
Chassis mounting angle bracket (right)	P244-2
National Co. insignia	J791-4
Bracket for S meter	J970-2
Rubber mounting foot (4)	K899-2
Cabinet back	SA:9276
Cabinet cover	J701-8
Cabinet bottom	SA:6588
Cabinet wraparound	SA:9271
Coverhinge (2)	J825-2
Cover stop angle (2)	K788-1
Knob for oscillator trimmer	SA:7021
Knob for band scale selector	SA:7021
MECHANICAL PARTS USED ON RACK MODEL ONLY	
Front panel	SA:9281
Side plate (left)	P302-1
Side plate (right)	P302-3
National Co. insignia	J791-3
Dust cover	SA:9283
Thumb screw for dust cover (2)	L309-2
Knob for oscillator trimmer	SA:7469
Knob for band scale selector	SA:7470

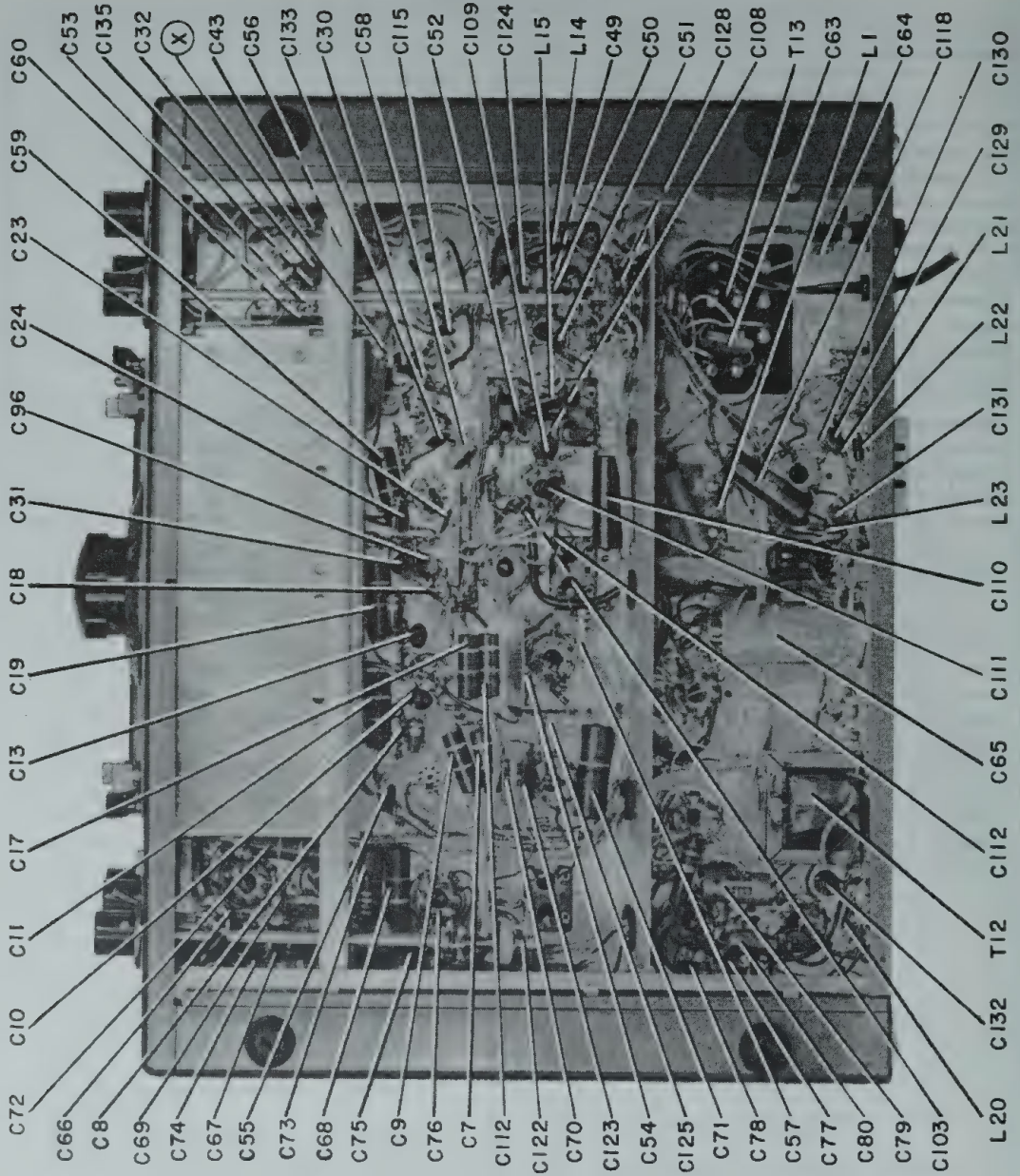

Figure No. 10A. Resistor Locations, Bottom View of Receiver

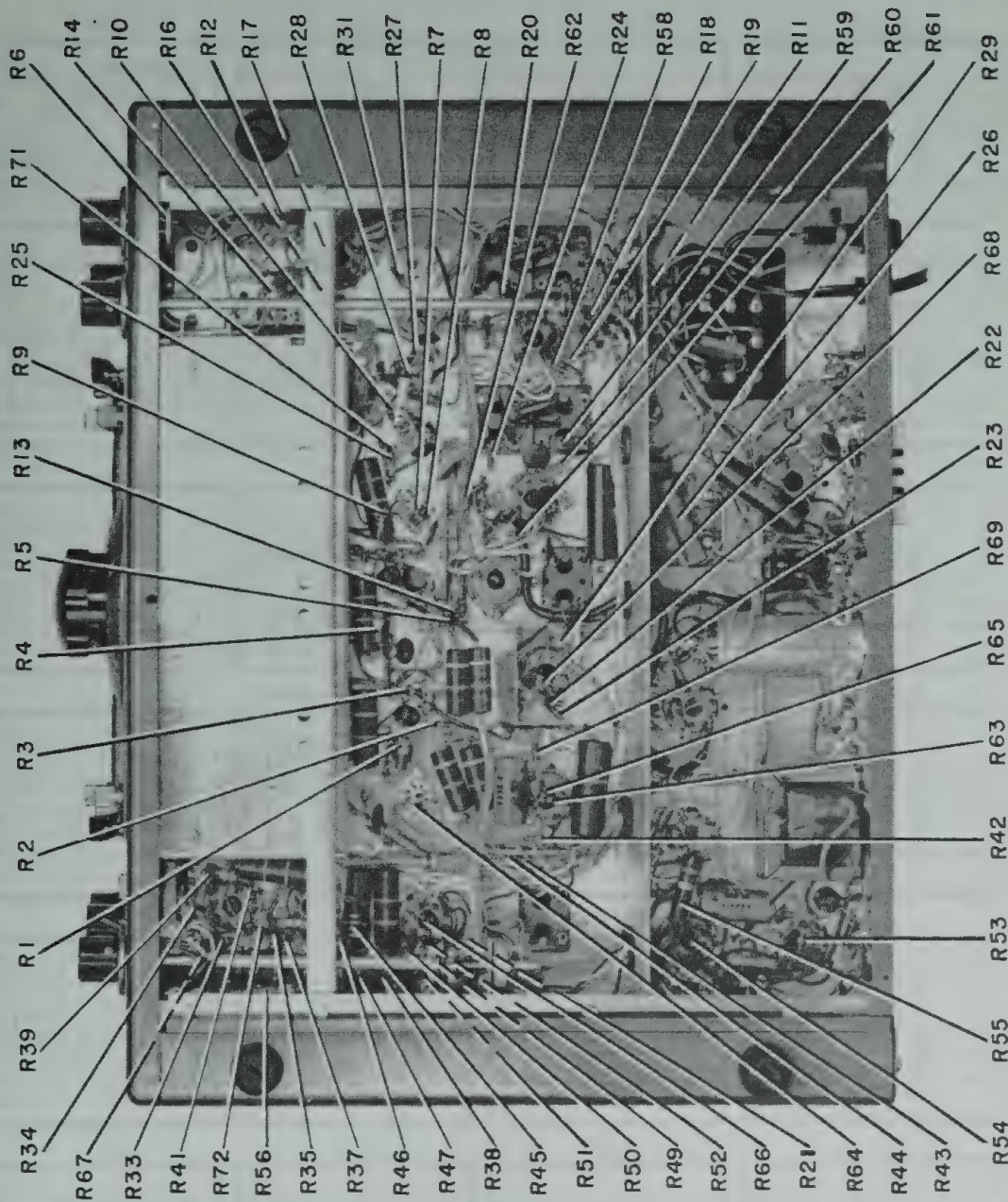

Figure No. 10B. Capacitor and Miscellaneous Component Locations, Bottom View of Receiver

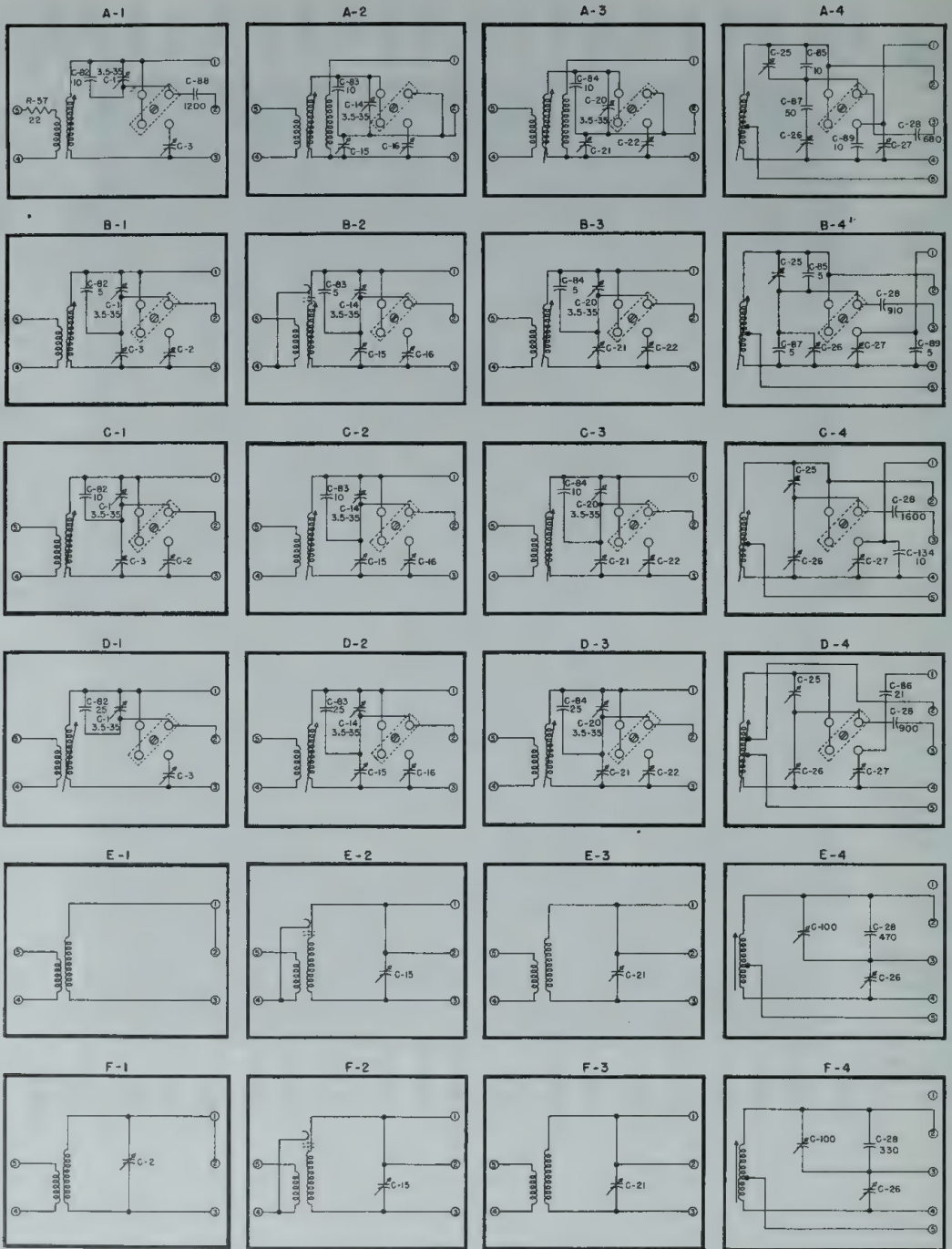

Figure No. 11. Schematic Diagram, Coil Sets A, B, C, D, E and F

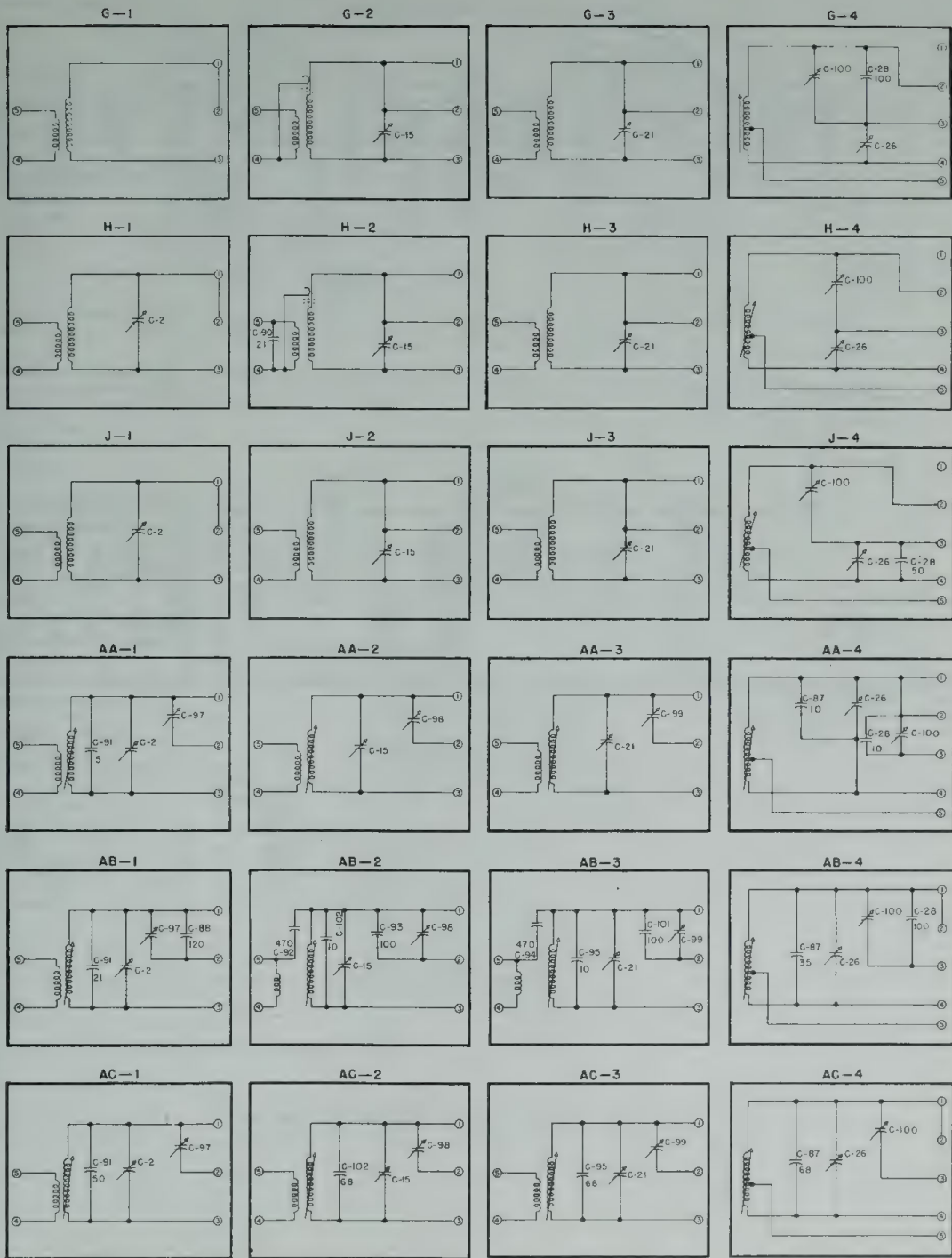

Figure No. 12. Schematic Diagram, Coil Sets AA, AB, AC, G, H and J

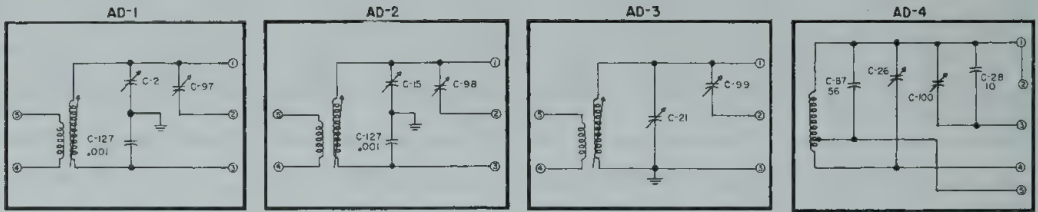
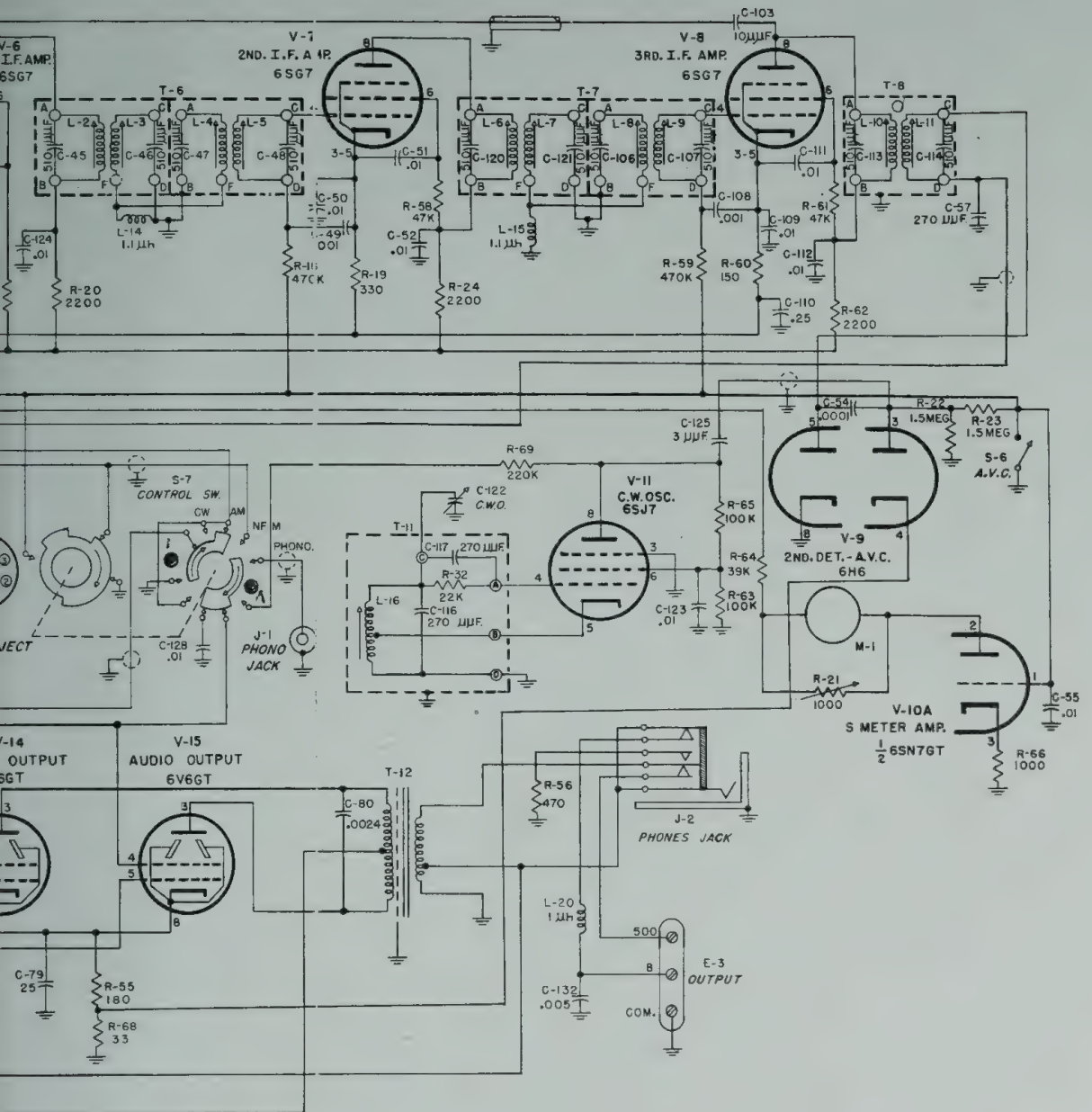

Figure No. 13. Schematic Diagram, AD Coil Set



VALUES = MICROFARADS EXCEPT AS NOTED
 RESISTOR VALUES = OHMS
 K = 1000

Figure No. 14. Schematic Diagram, HRO-60 Radio Receiver

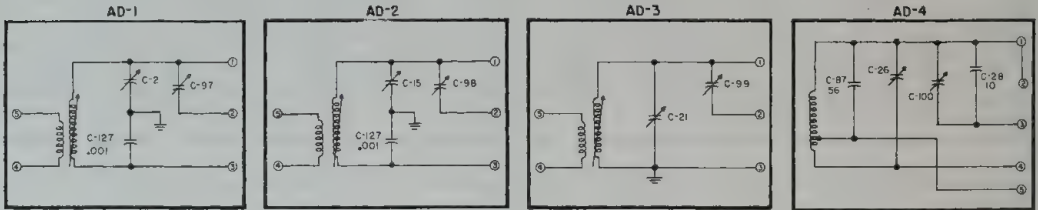

Figure No. 13. Schematic Diagram, AD Coil Set

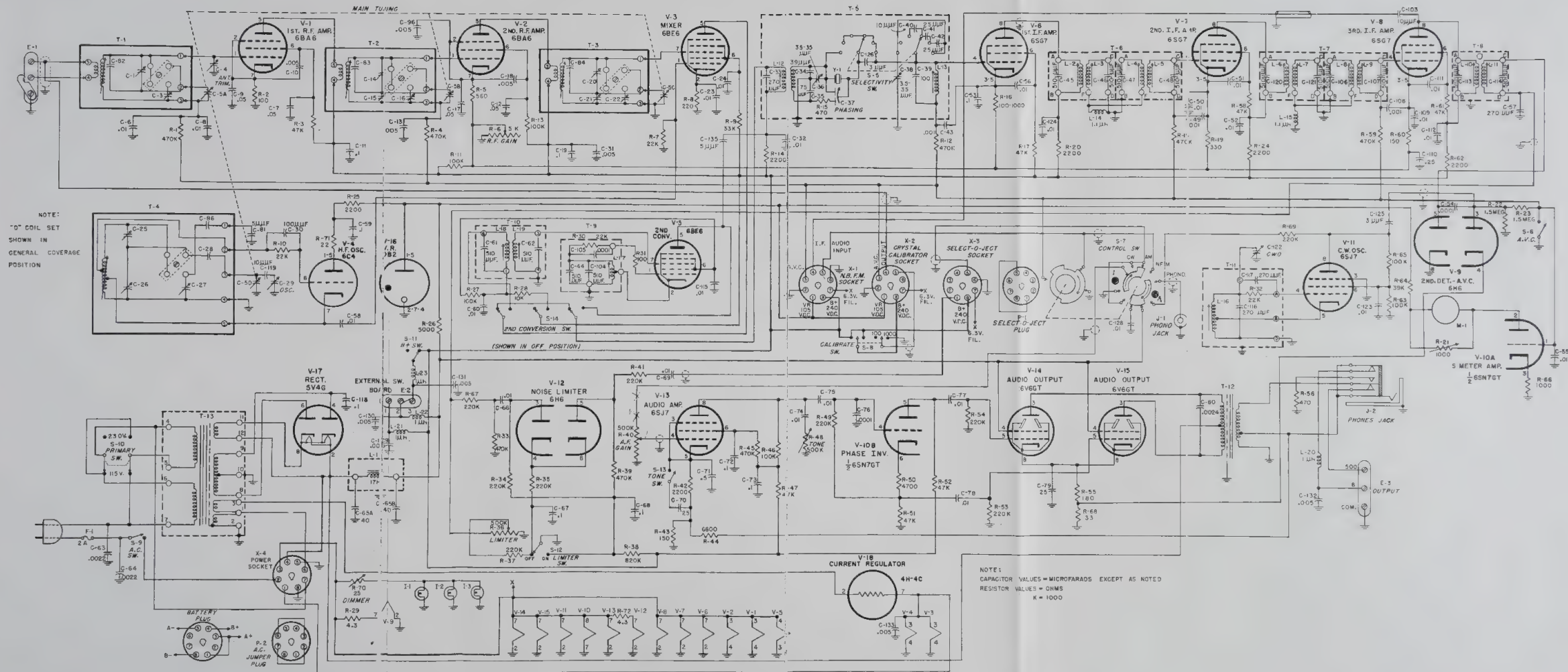

Figure No. 14. Schematic Diagram, HRO-60 Radio Receiver

SECTION 6.

ACCESSORIES

XCU-50-2 CRYSTAL CALIBRATOR

NFM-83-50 NARROW-BAND F.M. ADAPTOR

650S VIBRATOR POWER SUPPLY

MRR-2 MOUNTING RACK

**INSTRUCTIONS
FOR THE
NATIONAL XCU-50-2
CRYSTAL CALIBRATOR UNIT**

GENERAL

The type XCU-50-2 Crystal Calibrator Unit is designed expressly for use within HRO receivers. It utilizes an electron-coupled oscillator circuit controlled by a dual crystal (Valpey type DFS). This type of crystal provides two crystal-controlled marker frequencies of 100 kilocycles and 1 megacycle. When plugged into the Crystal Calibrator Socket, X-2, the XCU output is loosely coupled to the first R.F. amplifier input circuit. Selection of either the 100 kilocycle or 1000 kilocycle crystal-controlled signal is made possible by the front-panel mounted Calibrate switch on the receiver.

INSTALLATION

The XCU-50-2 calibrator is installed in the HRO-60 receiver by plugging the unit into the Crystal Calibrator Socket, X-2, on top of the chassis. A slotted-head screw mounted through the top of the unit is provided to bolt the unit to the chassis.

A trimmer capacitor, C-1, is connected across the crystal to permit adjustment of the frequency of the 100 kilocycle output marker when the unit is operated at locations where the temperature is vastly removed from that of normal room temperature. This capacitor should never require adjustment unless such abnormal temperatures are experienced. To make the adjustment proceed as follows:

- (1) Plug in a coil set suitable for the reception of WWV on one of the various frequencies utilized by this standard frequency station.
- (2) Adjust the receiver for normal A.M. operation as explained in Section 3-3.
- (3) Set the front-panel mounted Calibrate switch at the 100 kilocycle position.
- (4) Tune in the signal from WWV at a time when the signal is unmodulated.
- (5) Adjust the trimmer capacitor, C-1, located at the top of the calibrator unit so that the 100 kilocycle marker signal harmonic is zero beat with the signal received from WWV.

OPERATION

The XCU-50-2 Crystal Calibrator provides a means of checking the accuracy of the frequency calibration of the receiver. The front-panel mounted Calibrate switch marked 100-Off-1000 connects B-plus to the Calibrator for instantaneous service. At the same time this switch selects either the 100 or 1000 kilocycle marker signal. To check calibration accuracy tune in the desired marker signal with the Control switch set at C.W. and zero beat the receiver with the harmonic marker. If the micrometer dial and the slide-rule dial do not read accurately correction should be made by adjusting the front-panel mounted Osc. trimmer control. Only a slight adjustment of the Osc. trimmer control should be necessary. If calibration is way off the plug-in coil set probably requires realignment and reference should be made to Section 4.

PARTS LIST

SYMBOL	FUNCTION	DESCRIPTION	NAT. CO. TYPE
C-1	100 Kc. tuning	Ceramic, variable, 6-20 mmf.	E311-2
C-2	B+ Filter	Paper, .1 mfd. 400 vdcw	D827-12
C-3	Screen Filter	Paper, .1 mfd. 400 vdcw	D827-12
C-4	Output Coupling	Ceramic, 10 mmf. 500 vdcw	H872-1
C-5	Feedback	Ceramic, 3 mmf. 500 vdcw	J695-4
C-6	Screen Bypass	Ceramic, 100 mmf. 500 vdcw	D825D421
L-1	100 Kc. inductor	5 mh. type R-100	SA:2608
L-2	1000 Kc. inductor	160 microhenries	SB:1136
P-1	Plug	Octal	K783-1
R-1	Grid	Fixed, 4.7 megohms, 1/2 W	J569-69
R-2	Not used		
R-3	Screen Dropping	Fixed, 22,000 ohms, 1 W	J571-41
R-4	Plate	Fixed, 470,000 ohms, 1 W	J571-57
V-1	Oscillator tube	6AK6	
Y-1	Crystal Resonator	Quartz, 100-1000 Kc.	Q560-1

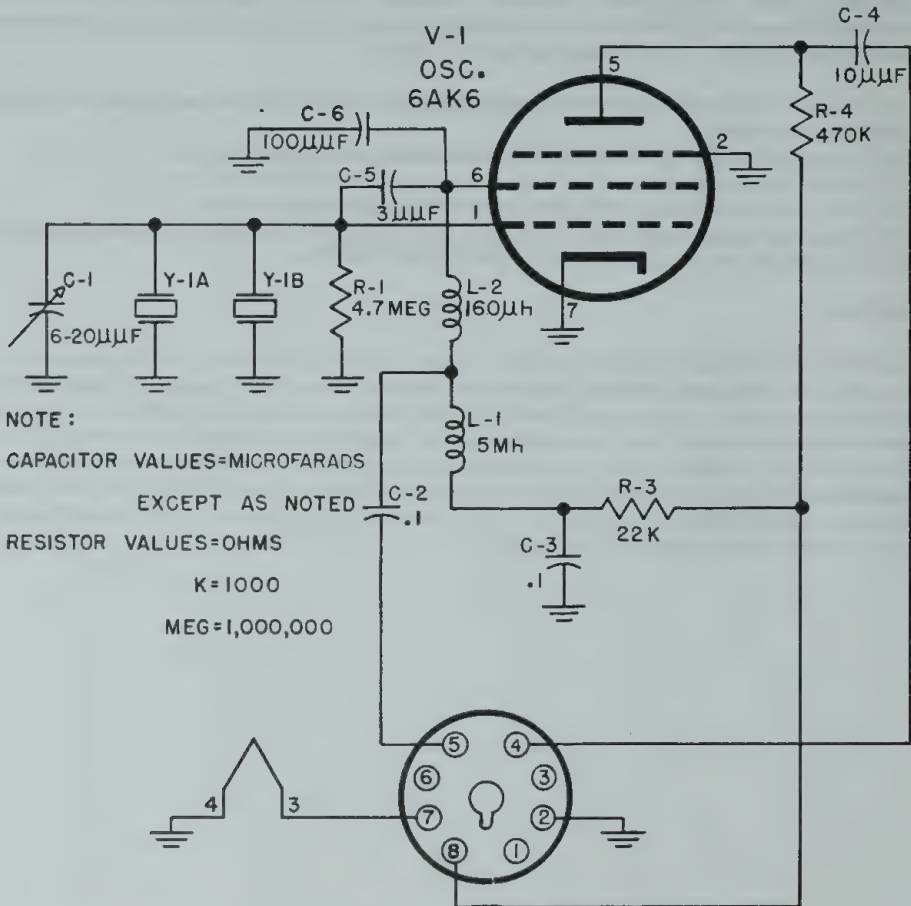

Figure No. 15. Schematic Diagram, XCU-50-2 Calibrator

**INSTRUCTIONS
FOR THE
NATIONAL NFM-83-50
NARROW-BAND F.M. ADAPTOR**

INSTALLATION

The NFM-83-50 is installed in the HRO-60 receiver by plugging the adaptor unit into the N.B.F.M. Socket X-1 on the top of the chassis. A mounting bracket is furnished to hold the adaptor unit securely in position. The adaptor unit is aligned at National Company laboratories and realignment is not necessary.

ALIGNMENT

The NFM-83-50 is carefully aligned before shipment and no realignment is required unless the adaptor is accidentally misaligned. The necessity of realignment can be determined by the A.M. rejection capabilities of the adaptor unit. Proper alignment will be indicated when the maximum A.M. rejection occurs at the center of the A.M. carrier. Maximum S-meter reading will indicate the center of the carrier.

The equipment required for alignment is a high-impedance vacuum tube voltmeter and an A.M. signal generator. The signal generator used should have an output reasonably free of any frequency modulation. The use of a broadcast station as a signal source, in place of a signal generator, would provide a test signal meeting the above requirement. In any case, the signal strength of the test signal should be of the order to provide an S-meter reading of from 2 to 5 S-units when the HRO-60 is correctly tuned to the test signal.

The preliminary alignment procedure is as follows:

1. Connect the high-impedance voltmeter between the test point jack, J-1, and chassis. The polarity of the voltage will depend on the alignment of the adaptor, connect the voltmeter to obtain an up-scale reading.
2. Connect a signal source to the antenna terminals, A and A, at the rear of the HRO-60. If a signal generator is used make the connection through a 300 ohm dummy load and select a frequency in the standard broadcast band.
3. Set the Control switch at N.F.M.
4. Set the Selectivity switch at Off.
5. Set the Limiter control at Off.
6. Plug in the E coil set, 900 to 2,050 kc. If this coil set is not available use the D coil set, 1.7 to 4.0 Mc.
7. Set the B plus switch at On.
8. Set the A.V.C.-Off switch at A.V.C.
9. Turn the R.F. Gain control to 10.
10. Adjust the A.F. Gain control for the desired volume.
11. Tune the test signal by adjustment of the Main Tuning knob. The correct tuning point is the setting that produces maximum S-meter reading.

Alignment is effected as follows:

1. Detune both primary, L-1, and secondary L-2, I.F. trimmers by rotating the screw adjustments until they are withdrawn from the shield can as far as possible. The adjustment with the dot of red paint opposite it is the primary trimmer L-1.
2. Tune the primary trimmer, L-1, for maximum reading on the voltmeter. If two peaks in output are observed, the correct peak will be the first one encountered when rotating the screw adjustment into the shield can.
3. Tune the secondary trimmer, L-2, for a zero reading on the voltmeter. It will be noted that there is a crossover in the polarity of the test voltage at this point.
4. Adjust the capacitor, C-9, for a null in the audio output. This capacitor is accessible after removal of the button plug on the side of the adaptor unit.
5. Adjustment of capacitor, C-9, may affect the zero voltage reading obtained by adjustment of the secondary trimmer, L-2. Retrim L-2 and C-9, as necessary, until both a zero voltage reading on the voltmeter and a null in the audio output are obtained.

PARTS LIST

SYMBOL	FUNCTION	DESCRIPTION	NAT. CO. TYPE
C-1	I.F. Amp. Coupling	Ceramic, 10 Mmf, 500 vdcw	D825D-402
C-2	Input Divider	Ceramic, 38.5 Mmf, 500 vdcw	D825D-414
C-3	I.F. Amp. Cathode Bypass	Mica, 0.01 Mfd, 300 vdcw	J666-56
C-4	I.F. Amp. Screen Bypass	Mica, 0.001 Mfd, 300 vdcw	J665-71
C-5	T-1 Primary Tuning	Mica, 100 Mmf, 500 vdcw	H500-7
C-6	T-1 Secondary Tuning	Mica, 180 Mmf, 500 vdcw	H500-3
C-7	T-1 Secondary Tuning	Mica, 180 Mmf, 500 vdcw	H500-3
C-8	T-1 Secondary Tuning	Ceramic, 38 Mmf, 500 vdcw	D825D-424
C-9	T-1 Sec. Balance Adjustment	Ceramic, Variable, 7-35 Mmf.	E311-4
C-10	Dis. Cathode Filter	Elect. 1 Mfd, 450 vdcw	E338-10
C-11	B Supply Bypass	Mica, 0.01 Mfd, 300 vdcw	J666-56
C-12	R.F. Filter	Mica, 470 Mmf, 500 vdcw	J665-56
C-13	Audio Coupling	Mica, 0.01 Mfd, 300 vdcw	J666-56
R-1	I.F. Amp. Grid Leak	Fixed, 1 Megohm, 1/2 W	K379-61
R-2	I.F. Amp. Cathode Bias	Fixed, 1,000 Ohms, 1/2 W	K379-25
R-3	I.F. Amp. Screen Dropping	Fixed, 47,000 Ohms, 1/2 W	K379-45
R-4	R.F. Filter	Fixed, 47,000 Ohms, 1/2 W	K379-45
R-5	Diode Load	Fixed, 15,000 Ohms, 1/2 W	K379-39
R-6	Diode Load	Fixed, 15,000 Ohms, 1/2 W	K379-39
R-7	Decoupling	Fixed, 4,700 Ohms, 1/2 W	J569-33
J-1	Test Point	Tip Jack, Bakelite	K421-1
L-1	T-1 Primary Inductor	Adjustable Iron-Core	SA:4892
L-2	T-1 Secondary Inductor	Adjustable Iron-Core	SA:4891
P-1	Adaptor Unit Plug	8 Prong Octal	K783-1
T-1	Discriminator Transformer	Ratio Type 455 Kc.	SA:4890
V-1	I.F. Amplifier	6SK7	
V-2	Discriminator	6H6	

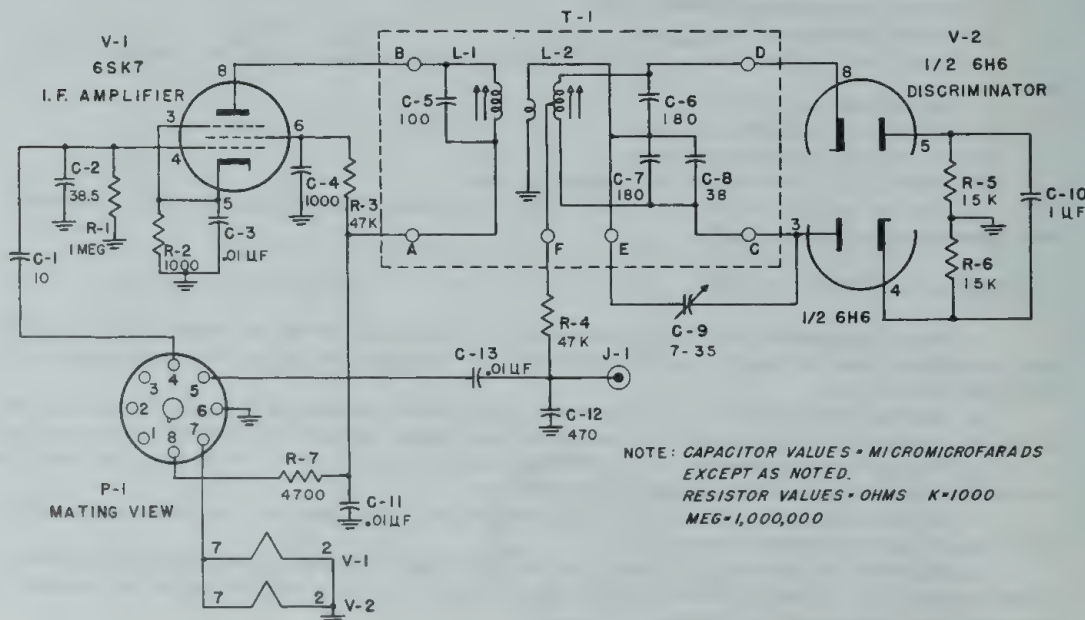

Figure No. 16. Schematic Diagram, NFM-83-50 Adaptor

**INSTRUCTIONS
FOR THE
NATIONAL TYPE 650S
VIBRATOR POWER SUPPLY**

GENERAL

The National Type 650S Table Model Vibrator Power Unit has been designed to furnish complete operating voltages for the HRO-60 receiver. The unit operates from a 6-volt D.C. supply and provides approximately 150 volts D.C. at 70 milliamperes in normal operation. Output voltages for both A and B supply are available at a four prong socket for convenient connection to the Receiver.

The 650S consists of a vibrator unit utilizing an OZ4A type rectifier tube and a vibrator in a circuit employing efficient R.F. filtering of vibrator hash. Further filtering of the low frequency or audio hum component in the output is accomplished by using the regular filter system in the receiver.

INSTALLATION

The 650S unit is supplied with a battery connecting cable as well as an interconnecting cable to facilitate connection to the receiver.

Battery clips are provided on the battery connecting cable W-1 for convenient connection to a 6-volt storage battery or similar source of power. The interconnecting cable W-2 is terminated at one end in a four-prong plug to mate with the socket X-1 of the 650S. The other end utilizes an octal plug to mate with the power socket X-4 at the rear of the HRO-60 receiver. The receiver A.C. jumper plug P-2 used for A.C. operation must be removed from the power socket. Figure Number 17 shows the Schematic Wiring Diagram.

The 650S Vibrapack Unit has been completely tested and adjusted at the factory to provide efficient and economical service when used with the HRO-60 receiver. An adjustment control switch has been furnished for increasing the B-plus output. This is a screwdriver control available through an entry hole provided at the rear of the 650S. The control switch has four steps from approximately 150 volts of filtered D.C. at 70 milliamperes in the extreme counterclockwise position (step 1) to approximately 210 volts at 90 milliamperes in the fully clockwise position (step 4). It is recommended that the receiver be operated at the lower B voltage in step 1. The total battery drain is approximately 11 amperes when furnishing power to the receiver if the NFM-83-50, XCU-50-2 and SOJ-3 units are used. If the receiver is used without these accessories the total drain is approximately 9.5 amperes. The V.R. tube does not light under these conditions but the receiver will operate normally and operation from a storage battery becomes practical. In step 4 the V.R. tube will light and full receiver output will be obtained but the drain on the storage battery will be approximately 15.5 amperes when all accessories are utilized. Without these accessories the total receiver drain from the battery will be approximately 13.8 amperes.

The two intermediate control switch steps 2 and 3 should not be used as the voltage obtained is approximately the value required to fire the V.R. tube in the receiver. Under this condition the V.R. tube may fire on and off sporadically resulting in erratic operation of the receiver.

PARTS LIST

SYMBOL	FUNCTION	DESCRIPTION	NAT. CO. TYPE
C-1	Filter Capacitor	Elec. 500 mfd. 15 vdcw	E338-7
E-1	Vibrapack Unit	6 V.D.C. Mallory Type VP554	Q371-1
F-1	Fuse	20 Amperes 25 volts type 3 AG	F135-18
L-1	6-volt Line Filter	16 microhenries, iron core	SA:869
S-1	6-volt Line Switch	Toggle S.P.S.T.	E230-2
V-1	Rectifier Tube	Type OZ4A	
W-1	6-volt Line Connector	Two Contact	SA:1999
W-2	Interconnecting Cable	One end terminated in four prong plug; other in an octal plug	
Y-1	Vibrator	6 V.D.C. Mallory Type 825C	
X-1	Output Socket	Four Prong Female	E319-9

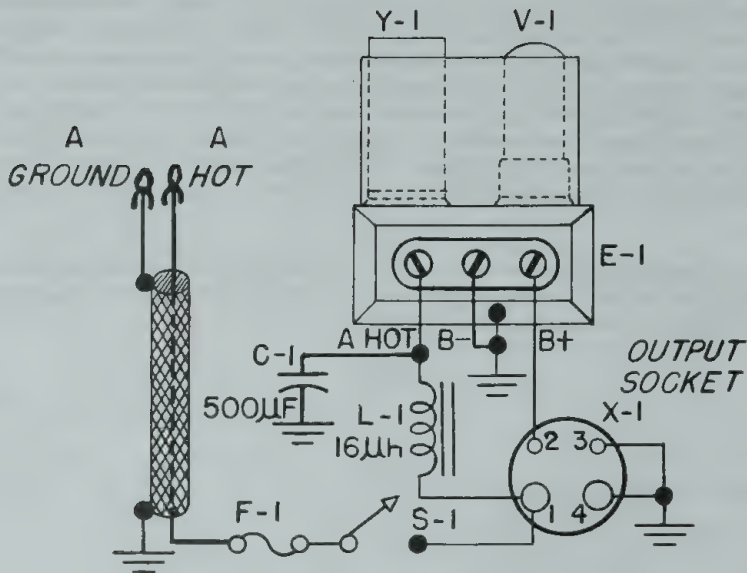

Figure No. 17. Schematic Diagram, 650S Vibrator Power Supply

**INSTRUCTIONS
FOR THE
NATIONAL MRR-2
MOUNTING RACK**

The MRR-2 Mounting Rack is shipped from the factory in knocked-down form with all necessary hardware. Assemble the rack according to Figure No. 18.

STEP NO. 1

FASTEN THE TWO NARROW STEEL STRIPS TO THE ANGLE UPRIGHTS USING THE FOUR # 8-32 FLAT HEAD SCREWS.

STEP NO. 2

USING THE FOUR FLAT HEAD 1/4"-20 SCREWS AND NUTS FASTEN THE TWO STEEL STRIPS FROM CORNER TO CORNER OF THE ANGLE IRON BASE. INSERT SCREWS THROUGH THE BOTTOM OF THE BASE USING THE OUTSIDE HOLES. (THE INNER HOLES ARE USED FOR MOUNTING THE RACK TO THE BENCH IF DESIRED.)

STEP NO. 3

INSTALL THE EQUIPMENT IN THE RACK USING THE # 8-32 TRUSS HEAD SCREWS.

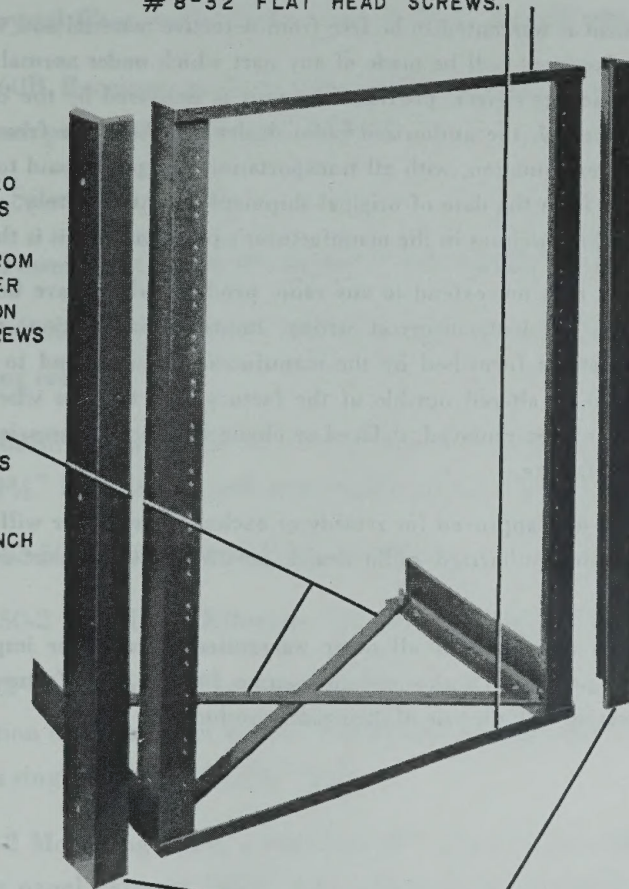

STEP NO. 4

FASTEN THE TRIM STRIPS USING THREE TRUSS HEAD SCREWS ON EACH STRIP.

Figure No. 18. MRR-2 Rack, Assembly Instructions

Standard Form Warranty

Adopted by the Radio Manufacturers Association, Inc.

This equipment is warranted to be free from defective material and workmanship and repair or replacement will be made of any part which under normal installation, use and service discloses defect, provided the unit is delivered by the owner to the manufacturer or through the authorized radio dealer or wholesaler from whom purchased, intact, for examination, with all transportation charges prepaid to the factory, within ninety days from the date of original shipment from the factory, and provided that such examination discloses in the manufacturer's judgment that it is thus defective.

This warranty does not extend to any radio products which have been subjected to misuse, neglect, accident, incorrect wiring, improper installation, or to use in violation of instructions furnished by the manufacturer, nor extend to units which have been repaired or altered outside of the factory, nor to cases where the serial number thereof has been removed, defaced or changed, nor to accessories used therewith of other manufacture.

Any part of a unit approved for remedy or exchange hereunder will be remedied or exchanged by the authorized radio dealer or wholesaler without charge to the owner.

This warranty is in lieu of all other warranties expressed or implied and no representative or person is authorized to assume for the manufacturer any other liability in connection with the sale of their radio products.

National Company, Inc. reserves the right to make any change in design or to make addition to, or improvements in, its products without imposing any obligations upon itself to install them in its products previously manufactured.

THE NATIONAL HRO-60 RECEIVER

EQUIPMENT LIST

HRO-60T Receiver, table mounting, gray finish, complete with tubes, crystal filter, noise limiter, and A, B, C, D, coil sets.

HRO-60R Receiver, same as above but mounted on a $\frac{1}{8}$ " standard rack panel $10\frac{1}{2}$ " high, gray finish.

SOJ-3 Select-O-Ject Unit.

650S Power Unit, table mounting, 6 volt battery operated vibrator.

HRO-60TS Table Model 10" PM dynamic loudspeaker with connecting cable.

HRO-60RS Loudspeaker 8" PM dynamic loudspeaker mounted on $8\frac{3}{4}$ " high rack panel, gray finish with connecting cable.

NFM-83-50 Narrow Band F.M. Adaptor.

XCU-50-2 100/1000 Kilocycle Crystal Calibrator Unit.

60SC-2 Combination Unit, an installation consisting of an eight section coil container and 8" PM dynamic loudspeaker mounted on a single rack panel $15\frac{3}{4}$ " high.

MRR-2 Mounting Rack, a standard 19" panel width table rack with a panel capacity $26\frac{1}{4}$ " high. Trim strips included.

Prices on Application

National National Co., Inc., Malden, Mass., U.S.A.





NATIONAL COMPANY, INC.
MALDEN, MASS.
U. S. A.