

Cricket 30

Assembly Manual v. 0.1

Copyright – 2018

David Cripe NM0S
The 4 State QRP Group

Introduction

Thank you for purchasing a CRICKET 30 Transceiver. We hope you will enjoy building it and find it a fun addition to your QRP station. This kit was conceived to fill a need within the hobby for an inexpensive, easy to build transceiver with performance a step above anything else available in this price range.

High quality, double sided printed circuit board construction is used, with solder mask and silk screened component reference designators. All components are through-hole for easy assembly. NO toroids are required. The CRICKET can be constructed by beginners as well as experienced builders. Construction time is approximately 1 - 2 hours, depending on experience level.

Specifications:

Voltage Input:	9v battery, clips mounted to board
Receive Current:	<20mA typical
Transmit Power:	0.75w, typical
Transmit Current:	<120 mA
Operating Frequency:	10.104 MHz, crystal included.
Antenna Connector:	BNC, on board
MDS:	-105 dBm, typical
Audio jack:	1/8" Stereo
Key Jack:	1/8"
T/R Offset:	600 Hz, typical
Sidetone:	Included!
Key:	Included!
Toroids:	None!
Wiring:	None!

First Steps

Before getting started with building the CRICKET, take some time to organize and familiarize yourself with the parts provided and check them against the Parts List. Building over a cookie sheet is recommended to minimize parts being lost. To prevent static damage, it is recommended that the ICs not be removed from their anti-static packaging until you are ready to install them. If parts are missing in your kit, send an

email to the CRICKET kitter listed at 4SQR.com. He will promptly provide replacements.

It is helpful to acquire the necessary tools and supplies before beginning. These include:

*Soldering iron – 20 to 30W, preferably thermostatically controlled.

*Fine 60/40 rosin core solder

*Diagonal cutters

*Needle-nose pliers

*Fine file or emery board

*Flat blade and Phillips screwdrivers

*Clear fingernail polish

Schematic and Component Placement diagrams are provided as part of documentation package. It is highly recommended to print a copy for reference during construction. As you build, you can check off each construction step as you complete them in order.

When you think you are done, you can check the list to verify that all of the parts have been installed.

Step 1 - Key

() Snap off the key strip and keying adapter, which are the ½” wide sections at the right-most side of the board. The board is scored with a V-groove so that they break free readily. Once separated, lightly sand the rough edges of the break until smooth.

() Locate the knob and the 8-32 screw (this is the larger of the 3 screws provided). Assemble the knob onto the board by inserting the screw through the silver side of the key board, and tightening the knob onto it.

Step 2 – Battery Connectors

() Locate the two battery clips. Obtain a 9v battery. We need to be sure that the spacing of the battery clips on the board is proper so that the battery will attach properly.

() Hold the battery flat with the terminals pointing away from you and the positive (+) terminal on the right. Snap the battery clips onto the battery, mounting pins facing down, and insert the battery clips through the holes on the board. Be careful not to let the clips touch and short out the battery!

() Double check that the positive terminal of the battery and the mating female battery clip is at the right. Flip the board over, holding the board down firmly on the battery, and solder the battery clips into place.

() Remove the battery, and proceed.

Step 3 – Resistors and Inductor

Insert and solder, and check off each when completed.

	<u>Ref</u>	<u>Value</u>	<u>Color Code</u>
<input type="checkbox"/>	R1	470	Yellow-Violet-Brown
<input type="checkbox"/>	R10	10k	Brown-Black-Orange
<input type="checkbox"/>	R2	1.0M	Brown-Black-Green
<input type="checkbox"/>	R3	1.0M	Brown-Black-Green
<input type="checkbox"/>	R6	1.0M	Brown-Black-Green
<input type="checkbox"/>	R9	1.5k	Brown-Green-Red
<input type="checkbox"/>	R4	330	Orange-Orange-Brown
<input type="checkbox"/>	R11	4.7K	Yellow-Violet-Red
<input type="checkbox"/>	R5	47k	Yellow-Violet-Orange
<input type="checkbox"/>	R7	47k	Yellow-Violet-Orange
<input type="checkbox"/>	R8	47k	Yellow-Violet-Orange
<input type="checkbox"/>	L4	27uH	Red-Violet-Black

Step 4 – Semiconductors

Be certain that these components are inserted correctly, according to the silkscreen diagram.

<input type="checkbox"/>	Q1	2N7000
<input type="checkbox"/>	Q2	2N7000
<input type="checkbox"/>	Q3	2N7000
<input type="checkbox"/>	Q4	2N7000
<input type="checkbox"/>	Q5	2N7000
<input type="checkbox"/>	Q6	2N7000
<input type="checkbox"/>	Q7	SS8550
<input type="checkbox"/>	D1	1N914
<input type="checkbox"/>	D2	1N914
<input type="checkbox"/>	D3	1N914
<input type="checkbox"/>	U1	NJM2113

Step 5 – Capacitors

Be certain to insert C14 in the proper polarity orientation as labeled in the board.

	<u>Ref</u>	<u>Value</u>	<u>Type</u>	<u>Label</u>
<input type="checkbox"/>	C2	0.01	Ceramic Disk	103
<input type="checkbox"/>	C7	0.01	Ceramic Disk	103

()	C16	0.01	Ceramic Disk	103
()	C8	0.1	Ceramic Disk	104
()	C17	0.1	Ceramic Disk	104
()	C11	1.0	Monolithic	105
()	C13	1.0	Monolithic	105
()	C14	100u	Electrolytic	100u
()	C9	100p	Ceramic Disk	101
()	C15	150p	Ceramic Disk	151
()	C1	27p	Monolithic	270
()	C5	68p	Monolithic	680
()	C3	150p	Monolithic	151
()	C10	180p	Ceramic Disk	181
()	C18	180p	Ceramic Disk	181
()	C4	220p	Monolithic	221
()	C6	270p	Monolithic	271
()	C12	680p	Monolithic	681

Step 6 - Final Assembly

- () Solder the BNC connector to the board in the J1 position. Be careful in getting the center conductor inserted through the board – this wire is somewhat brittle.
- () Solder the SPDT power switch onto the board in the position to the left of the battery contacts.
- () Solder the headphone jack to the board in the J2 position.
- () Locate the six pin DIP socket. Using diagonal cutters, snip it in half to make two, three pin sockets. Use the diagonal cutters to clean up the broken face of the half-socket. Snip off the center lead of the socket flush to the black plastic body. Solder the socket onto the board in the X1/J4 position
- () Locate the 6-32 screws, aluminum spacers, and hex nuts. Assemble the key to the board by passing the screws through the top of the key assembly, and using the spacers between the key and the PC board. Install the nuts on the bottom side of the board, and tighten with the screwdriver. If desired, add a tiny drop of clear fingernail polish to the screw threads at the nut to help keep the nut from working loose.
- () Add the four adhesive rubber feet to the bottom of the board in the four corners.

Step 7 – Keying Adapter Option

For those wanting to key the Cricket using an external keyer, a special adapter is provided. It installs instead of the hand key, and includes a standard 1/8” jack to connect to a keyer circuit.

() Install the 1/8” audio jack to the keying adapter board.

() Install the knob to the board using the 8-32 screw with the two flat washers under the screwhead.

() Install the keying adapter to the board using the screws and spacers from the hand key assembly. When assembled, the screw head should firmly contact the keying pad beneath it.

You are done!

The Cricket is a minimalist 30M CW transceiver designed to be a simple, easy-to-build project. It is comprised of 43 electrical components, but maximizes features and performance of the parts it has.

This radio was designed for the Kit Building Workshop for Ozarkcon 2018. Selection of a build project for an event such as this is always a challenge, because there is always a good number of beginning hobbyists there for whom this might be their first soldering experience. It needs to be simple enough that it can be completed in an hour or so of allotted time for the event. Finally, it must be something useful and fun enough to be worth building.

The Cricket was designed to meet these requirements, as well as to be something *other* than the ubiquitous 40M radio kit that everyone has already built. The starting point was the notorious 'Pixie' transceiver...but from there, the resemblance ends!

For anyone who has actually built and operated one, the Pixie is a cheap and simple kit, but has serious performance deficiencies. It is underpowered (0.3W), its harmonic output does not meet FCC requirements, the receiver is a bit deaf, and very prone to AM broadcast bleedthrough and 60 Hz hum pickup.

The Cricket starts its circuit with that section of the Pixie that works well - the crystal oscillator. It's a very conventional Colpitts circuit, using a bipolar transistor as the active device.

The output of the oscillator is coupled to the gate of a 2N7000 MOSFET. This transistor is configured as a Class-E power amplifier, delivering 3/4W from a fresh 9v battery.

The output network uses spiral PC traces to make up the inductors, and all harmonics are attenuated at least 50 dB.

When the circuit is operating as a receiver, the key is open and there is no DC presented to the drain of the PA MOSFET, but the drive is present on the gate of the PA FET. RF signals entering from the antenna are mixed by the switching action of the PA FET, and converted to audio. This circuit is much more linear in its action than the bipolar transistor used in the Pixie, and results in better immunity to AM broadcast interference and 60 Hz hum.

The detected audio signal is coupled to U1, an NJM2113, which is a low-noise headphone driver IC.

When the key is closed, a number of things happen. Nine volts are applied to the drain choke, and the PA begins to generate RF power to the antenna. Voltage is applied to the gate of Q4, which mutes the audio amplifier, and voltage is applied to the Q5-Q6 sidetone oscillator circuit, sending the sidetone to the headphone jack. Voltage is also applied to the gate of Q3, which switches out the frequency offset capacitor in series with the crystal, permitting the transmitter to operate directly on the crystal frequency.

All this from 43 common electronic components!

The receiver is designed to drive a stereo output, either earbuds or speakers. If a mono speaker is plugged into the output jack, the receiver will still work, but the sidetone will no longer be audible.

73 Dave NM0S

CRICKET Component Placement

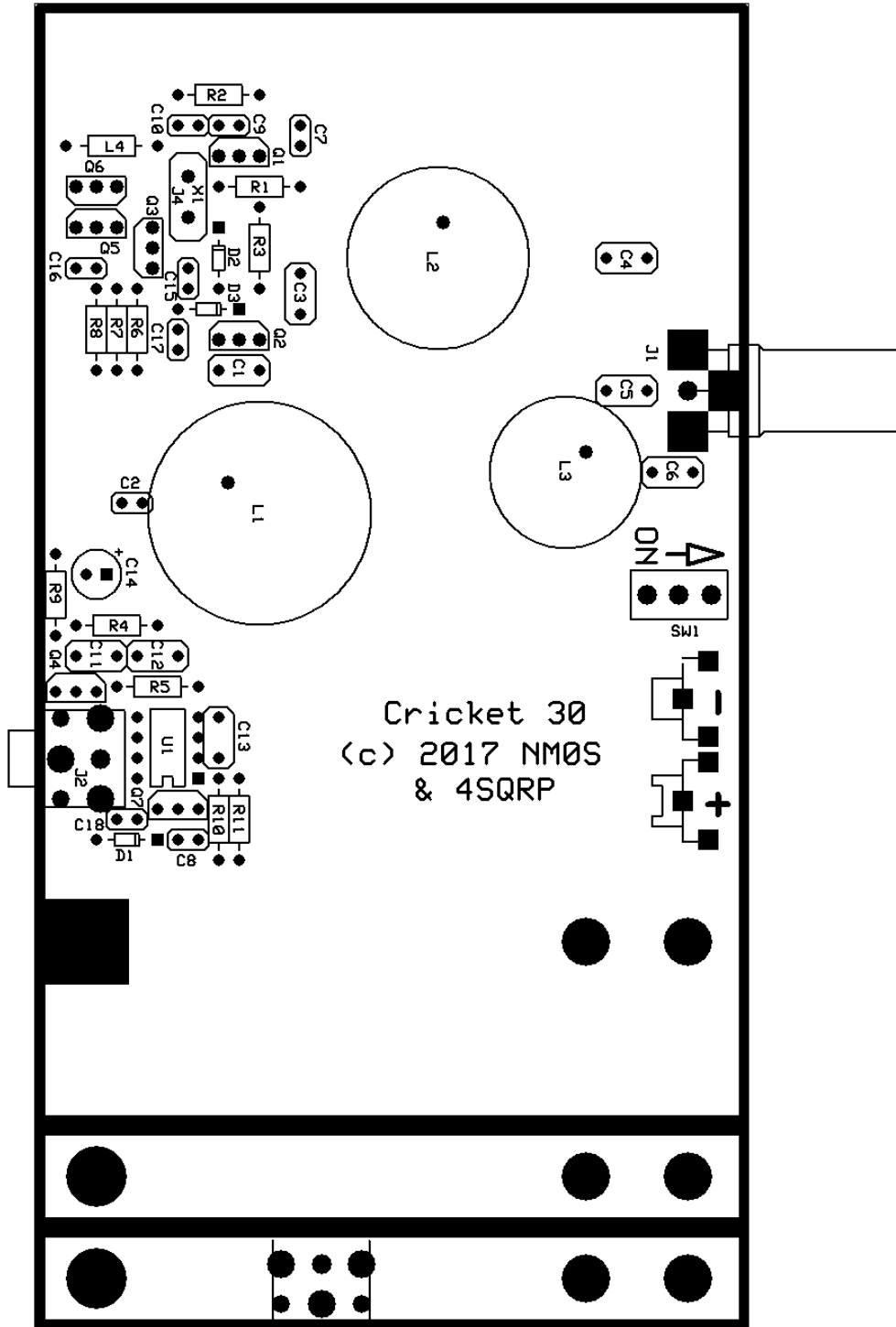

CRICKET Schematic

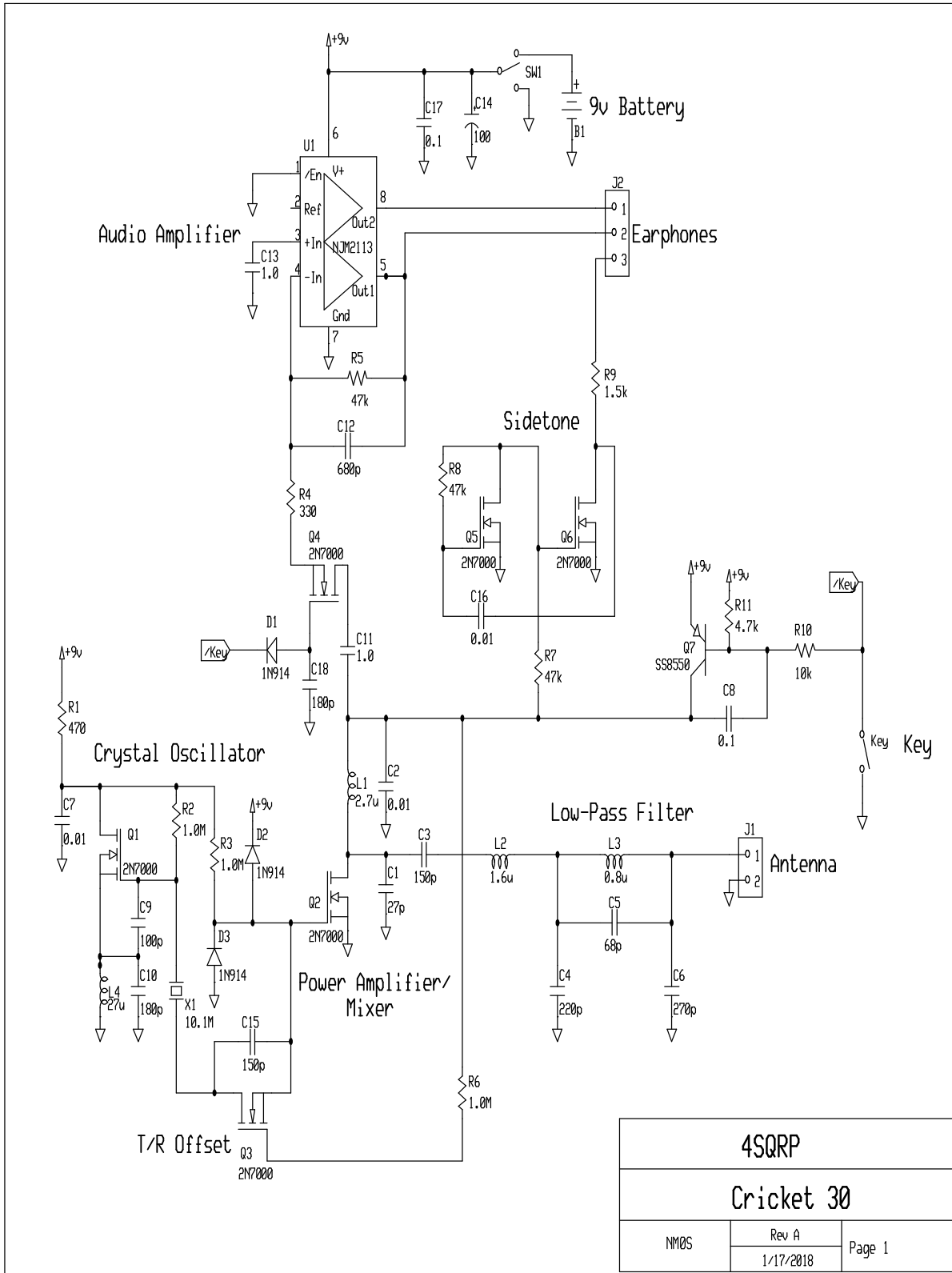

4SQRP		
Cricket 30		
NM0S	Rev A	Page 1
	1/17/2018	

PARTS LIST

Value	Description	Parts	Qty	Label
0.01u	Ceramic Disk	C2, C7, C16	3	103
0.1u	Ceramic Disk	C8, C17	2	104
1.0u	Monolithic	C11, C13	2	105
100u	Electrolytic	C14	1	100u
100p	Ceramic Disk	C9	1	101
27p	Monolithic	C1	1	270
150p	Ceramic Disk	C15	1	151
68p	Monolithic	C5	1	680
150p	Monolithic	C3	1	151
180p	Ceramic Disk	C10, C18	2	181
220p	Monolithic	C4	1	221
270p	Monolithic	C6	1	271
680p	Monolithic	C12	1	681
1N914	glass diode	D1, D2, D3	3	
ANT	BNC	J1	1	
Phones, Key	1/8" Stereo	J2, J3	2	
Xtal Socket	DIP Socket	J4	1	
Battery +	9v +	J5	1	
Battery -	9v -	J6	1	
27uH	Molded axial	L4	1	Red- violet-black
2N7000	TO-92 transistor	Q1,Q2,Q3,Q4,Q5,Q6	6	2N7000
SS8550	TO-92 transistor	Q7	1	8550
470	1/4w resistor	R1	1	Yellow-Violet-Brown
10k	1/4w resistor	R10	1	Brown-black-orange
1.0M	1/4w resistor	R2, R3, R6	3	Brown-black-green
1.5k	1/4w resistor	R9	1	brown-green-red
330	1/4w resistor	R4	1	orange-orange-brown
4.7k	1/4w resistor	R11	1	yellow-violet-red
47k	1/4w resistor	R5,R7,R8	3	yellow-violet-orange
SW1	SPDT	SW1	1	
NJM2113	DIP8 IC	U1	1	NJM2113
10.104MHz	Crystal	X1	1	10.104
10.110MHz	Crystal	X1	1	10.110
6-32 x 3/8	screw		2	
8-32 x 3/8	screw		1	
6-32 nut	nut		2	
6 - 1/8"	spacer		2	
#8	flat washer		2	
knob	knob		1	
rubber feet			4	
PCB			1	

Introduction to the Cricket

nm0s_qrp

Jan 18 10:20 AM

Welcome to the Group!

The Cricket is a minimalist CW family of transceivers for 80, 40, and 30 meters designed to be a simple, easy-to-build project. It is comprised of 49 components, but maximizes features and

This radio was designed as the Build-a-thon kit for Ozarkcon 2018. Selection of a build project for an event such as this is always a challenge, because there is always a good number of beginning hobbyists there for whom this might be their first soldering experience. It needs to be simple enough that it can be completed in an hour or so of allotted time for the event. Finally, it must be something useful and fun enough to be worth building.

The Cricket was designed to meet these requirements, as well as to be something _other than the ubiquitous 40M radio kit that everyone has already built. The starting point was the notorious 'Pixie' transceiver....but from there, the resemblance ends!

For anyone who has actually built and operated one, the Pixie is a cheap and simple kit, but has serious performance deficiencies. It is underpowered (0.3W), it's harmonic output does not meet FCC requirements, the receiver is a bit deaf, and very prone to AM broadcast bleedthrough and 60 Hz hum pickup.

The Cricket starts its circuit with that section of the Pixie that works well - the crystal oscillator. It's a very conventional Colpitts circuit, using a bipolar transistor as the active device.

The output of the oscillator is coupled to the gate of a 2N7000 MOSFET. This transistor is configured as a Class-E power amplifier, delivering 0.5W from a 9v battery. The output network uses spiral PC traces to make up the inductors, and all harmonics are attenuated at least 50 dB.

When the circuit is operating as a receiver, the key is open and there is not DC presented to the drain of the PA MOSFET, but the drive is present on the gate of the PA FET. RF signals entering from the antenna are mixed by the switching action of the PA FET, and converted to audio. This circuit is much more linear in its action than the bipolar transistor used in the Pixie, and results in better immunity to AM broadcast interference and 60 Hz hum.

The detected audio signal is coupled to U1, an NJM2113, which is a low-noise headphone driver IC.

When the key is closed, a number of things happen. 9v is applied to the drain choke, and the PA begins to generate RF power to the antenna. Voltage is applied to the gate of Q4, which mutes

the audio amplifier and voltage is applied to the Q5-Q6 sidetone oscillator circuit, sending the sidetone to the headphone jack. Voltage is also applied to the gate of Q3, which switches out the frequency offset capacitor in series with the crystal, permitting the transmitter to operate directly on the crystal frequency.

All this from 49 common electronic components.

It's a fun rig!

73 Dave NM0S

Introduction to the Cricket

nm0s_qrp

Jan 18 10:20 AM

Welcome to the Group!

The Cricket is a minimalist 30M CW transceiver designed to be a simple, easy-to-build project. It is comprised of 49 components, but maximizes features and performance of the parts it has.

This radio was designed as the Build-a-thon kit for Ozarkcon 2018. Selection of a build project for an event such as this is always a challenge, because there is always a good number of beginning hobbyists there for whom this might be their first soldering experience. It needs to be simple enough that it can be completed in an hour or so of allotted time for the event. Finally, it must be something useful and fun enough to be worth building.

The Cricket was designed to meet these requirements, as well as to be something _other than the ubiquitous 40M radio kit that everyone has already built. The starting point was the notorious 'Pixie' transceiver....but from there, the resemblance ends!

For anyone who has actually built and operated one, the Pixie is a cheap and simple kit, but has serious performance deficiencies. It is underpowered (0.3W), it's harmonic output does not meet FCC requirements, the receiver is a bit deaf, and very prone to AM broadcast bleedthrough and 60 Hz hum pickup.

The Cricket starts its circuit with that section of the Pixie that works well - the crystal oscillator. It's a very conventional Colpitts circuit, using a bipolar transistor as the active device.

The output of the oscillator is coupled to the gate of a 2N7000 MOSFET. This transistor is configured as a Class-E power amplifier, delivering 0.5W from a 9v battery. The output network uses spiral PC traces to make up the inductors, and all harmonics are attenuated at least 50 dB.

When the circuit is operating as a receiver, the key is open and there is not DC presented to the drain of the PA MOSFET, but the drive is present on the gate of the PA FET. RF signals entering from the antenna are mixed by the switching action of the PA FET, and converted to audio. This circuit is much more linear in its action than the bipolar transistor used in the Pixie, and results in better immunity to AM broadcast interference and 60 Hz hum.

The detected audio signal is coupled to U1, an NJM2113, which is a low-noise headphone driver IC.

When the key is closed, a number of things happen. 9v is applied to the drain choke, and the PA begins to generate RF power to the antenna. Voltage is applied to the gate of Q4, which mutes

the audio amplifier and voltage is applied to the Q5-Q6 sidetone oscillator circuit, sending the sidetone to the headphone jack. Voltage is also applied to the gate of Q3, which switches out the frequency offset capacitor in series with the crystal, permitting the transmitter to operate directly on the crystal frequency.

All this from 49 common electronic components.

It's a fun rig!

73 Dave NM0S