

INSTRUCTION MANUAL
FOR

QRP PLUS



INDEX LABORATORIES, 9318 Randall Dr. NW
Gig Harbor, WA 98332

INDEX LABORATORIES
HF Amateur Radio Transceiver

Contents

FEATURES	2
PUTTING THE QRP PLUS ON THE AIR	3
POWER	3
ANTENNA	4
KEY	5
PADDLE	5
MICROPHONE	5
EARPHONES	6
PANEL CONTROLS	6
OFF/VOL	6
MAIN TUNING	6
DISPLAY	6
ATTENUATOR	6
FAST	7
MEM	7
PWR/S METER	7
XCVE	7
REAR PANEL CONTROLS	8
SIDETONE LEVEL	8
CW POWER	8
MIC GAIN	8
RCVE ANT	9
SERVICE	9
REPLACING THE LITHIUM BATTERY	9
CALIBRATION	10
TRANSMITTER OUTPUT STAGE BIAS	10
S METER ZERO	10
SSB CARRIER NULL	11
SYNTHESIZER REFERENCE FREQUENCY	11
CIRCUIT DESCRIPTION	12
RECEIVE	12
SSB TRANSMIT	13
CW TRANSMIT	13

The base holder is located on the rear panel next to the power connector.

Some wall through power supplies do not provide sufficient filtering or regulation and should not be used with the QRP PLUS.

If the supply is not adequately regulated or if the instrument can't follow the steps (try work on spot or test point) shown in transmit when the indicator lamp turns the supply voltage to 14.4V (1.5V).

The QRP PLUS can be affected by strong nearby magnetic fields. Place the AC supply and power cord away from the transmitter.

QRP PLUS

FEATURES

The QRP PLUS is a compact low power transceiver with the features and performance you expect in a modern full size transceiver.

- All Band Operation 160M through 10M
- General Coverage Receiver 1.8MHZ to 29.7MHZ
- 20 Memories Can Be Set to Any Frequency in the Operating Range
- Provision for Efficient Split Operation
- High Performance SCAF Digital Filters Variable From 100HZ to 2400HZ
- Single Sideband and Full Break in CW Operation
- Built in Iambic Keyer
- Very Low Power Consumption on Receive

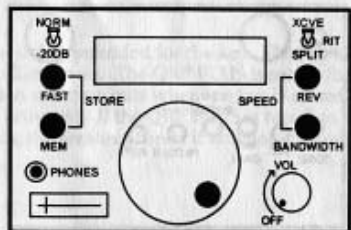

Figure 1: Front Panel

PUTTING THE QRP PLUS ON THE AIR

POWER

The QRP PLUS requires a source of 12V DC capable of supplying 1.5 ampere or more. The transceiver uses a coaxial power connector. A matching cable with pigtails is supplied. A well filtered power supply of 1.5 amp or greater capacity can be used. A gell cell of 4 amp hour or greater capacity will also work well. The QRP PLUS can be damaged by voltages greater than 15 Volts and will shut down if the supply voltage drops below 11 Volts.

Carefully observe the polarity when connecting the power source. The center post is positive and the outer shield is negative. The positive lead on the pigtail is identified with a red stripe. Reverse connection will not damage the QRP PLUS but will blow the fuse. It is a good idea to carry a spare fuse for portable operation. The QRP PLUS uses a standard 3AG 4AMP fast blow fuse. The fuse holder is located on the rear panel next to the power connector.

Some wall mounted power supplies do not provide sufficient filtering or regulation and should not be used with the QRP PLUS.

If the supply is not adequately regulated or if the battery is run down the unit may work in receive but shut down in transmit when the heavier load pulls the supply voltage below 11 Volts.

The QRP PLUS can be affected by strong nearby magnetic fields. Place an AC supply at least several inches away from the transceiver.

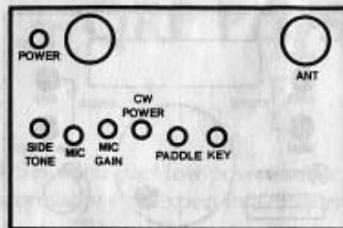

Figure 2: Rear Panel

Additional power connectors are available from Index Laboratories and may also be ordered from Mouser Electronics as P/N 709-1056 2.5mm X 5.5mm split pin power plug or P/N 171-0701 2.5mm X 5.5mm split pin power cable assembly.

ANTENNA

Successful QRP operation requires a reasonably efficient and well matched antenna. The QRP PLUS expects a 50 ohm matched load. Excellent results can be obtained with a 60 foot or longer random wire if a suitable antenna tuner is used. The tuner, SWR bridge and antenna should be connected as shown in Fig. 3. A good ground or counterpoise is important in the use of random wire antennas. Many excellent books are available for more refined antenna designs.

Unlike most solid state transmitters the QRP PLUS is not readily damaged by mismatch and does not shut itself down under high SWR mismatched conditions. However, intentional operation under mismatched conditions should be avoided. It is possible that the unit can generate spurious signals under certain extreme mismatched conditions.

The antenna connection is a standard SO-239 connector as shown in Fig. 2, rear panel.

Figure 3: Antenna Example

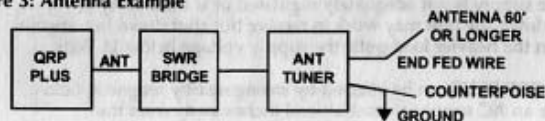

KEY

A 3.5 mm phone jack is provided for the key. The key sees 12 Volts at a few milliamperes. The QRP PLUS is set up for full break in operation and transmits when the key is closed. A sidetone is also activated. If the QRP PLUS is tuned to a frequency outside the amateur bands it will not transmit when the key is closed.

PADDLE

A 3.5mm stereo jack is provided for the keyer paddle. Connections are shown in Fig. 4. The tip connects to the dot paddle and the sleeve connects to the dash paddle.

Figure 4: Paddle Connections



MICROPHONE

The QRP PLUS is designed to be used with commonly available speaker microphones of the type sold for use with FM handheld transceivers. See Figure 5 for plug wiring details.

Figure 5: Microphone Connections

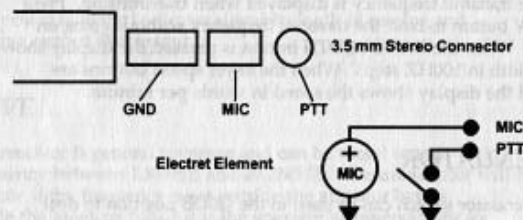

EARPHONES

Standard stereo headphones with 3.5mm stereo plug of the type used with walkmen etc. are used. When the phones are plugged in the speaker is disconnected.

PANEL CONTROLS (See Fig. 1, Front Panel)

OFF/VOL

The off/volume control switches power to the QRP PLUS and controls the loudness of received signals. The serial number of each unit is stored internally and will flash briefly on the display each time the QRP PLUS is turned on.

MAIN TUNING

The main tuning control serves a number of functions. It sets the frequency of operation. When the MEM button is pressed, the main tuning control steps from one stored frequency to the next. When the BANDWIDTH button is pressed it sets the receiver bandwidth and when the BANDWIDTH and REV buttons are pressed simultaneously it sets the keyer speed. In each case the frequency, bandwidth or speed is indicated on the LCD display.

DISPLAY

The LCD display shows frequency in 100HZ resolution although actual tuning is done in approximately 10HZ increments. In SPLIT or RIT modes the receive frequency is displayed when receiving and the transmit frequency is displayed when transmitting. Press the REV button to read the transmit frequency without going on the air. When the BANDWIDTH button is pressed the display shows bandwidth in 100HZ steps. When the keyer speed buttons are pressed the display shows the speed in words per minute.

ATTENUATOR

The attenuator switch can be used in the -20DB position to deal with unusually strong signals or high band noise. It is usually left in the NORM position.

FAST

The normal tuning rate is about 4KHZ per revolution. For rapid movement from one frequency to another the FAST button can be pressed while tuning. The fast tuning rate is about 100KHZ per revolution.

MEM

The QRP PLUS has 20 memories. It comes from the factory with the memories preset to a few frequencies in each amateur band. Any memory can be changed to any frequency desired. Press the MEM button and tune to the memory you wish to change. Tune to the new frequency using the FAST button if the new frequency is some distance from the old. Press the FAST button and hold while pressing the MEM button. The new frequency is now stored in the current memory.

The memories are retained with the use of an internal lithium battery. If for any reason the memories are lost they can be returned to the factory presets by holding the MEM button down while turning power on.

It is possible to toggle between two frequencies through use of the MEM button. For example, suppose you want to check a net frequency periodically while operating elsewhere in the band. Press the MEM button and the frequency will change to the current memory frequency. Tune to a new frequency. If you press the MEM again you will return to the stored frequency but if you press it once more you will return to the last used frequency. Each time you press MEM you will alternate between the current memory and the frequency last used.

PWR/S METER

The power/s meter indicates signal strength in receive and relative output in transmit.

XCVE

The receiver is general coverage and can be tuned to any frequency between 1.8MHZ and 29.7MHZ. The transmitter will not operate if the frequency is set outside the amateur bands. Inside the amateur bands it is the operator's responsibility to transmit only on modes and frequencies consistent with his or her class of license.

In the XCVE position the QRP PLUS receives and transmits on the same frequency.

Switch to RIT and the transmit frequency remains fixed while the receive frequency can be varied. Push the REV button while in RIT and the transmit frequency will be displayed and can be tuned while the receive frequency remains fixed. (XIT)

Working Split:

The DX station is listening up 5KHZ.

- 1 Tune in the DX station with the switch in the XCVE position.
- 2 Switch to SPLIT.
- 3 Press and hold the REV button while tuning to listen for other stations calling the DX.
- 4 When you have found the DX station's listening frequency, release the REV button and call. You will be transmitting on his listening frequency and listening on his transmitting frequency.

BANDWIDTH / MODE

Press the bandwidth button and the digital filter bandwidth will be displayed. It can be varied from .1 khz to 2.4 khz with the main tuning knob.

If the display shows SSB the frequency readout will be accurate for SSB signals. If the display shows CW, the frequency will be accurate for CW signals. To change from SSB to CW or back press the FAST button while holding the BANDWIDTH button.

REAR PANEL CONTROLS (See Fig. 2 Rear Panel)

SIDETONE LEVEL

This control adjusts the loudness of the CW sidetone relative to received signals. The sidetone level also tracks the front panel volume control. The sidetone level should be adjusted to suit your personal preference.

CW POWER

The CW POWER control adjusts the transmitter output power in CW mode. The power can be varied smoothly from zero to more than 5 watts. The front panel meter gives an approximate indication of

output power in watts. The output power for a given setting can vary some from band to band and also with different power supply voltages.

MIC GAIN

The microphone gain should be adjusted in the sideband transmit mode for approximately half scale meter readings on voice peaks. Avoid setting the mic gain too high. Excessive mic gain can cause distorted, difficult to read audio.

SERVICE

A one year warranty is provided with the QRP PLUS. Terms are detailed on the warranty card provided with the unit.

Service is provided at the factory. Please call the factory prior to returning a unit for service. You pay shipping to the factory. We pay return shipping on warranty service.

Opening or modifying a QRP PLUS transceiver does not automatically void the warranty. However, if, in the judgement of Index Laboratories a malfunction is the result of abuse or modification of the unit, service will be billed at standard rates.

When returning a unit please pack carefully using original packing material where possible.

Index Laboratories will make every effort to provide qualified technical support by telephone and can, when appropriate, provide replacement components or assemblies.

REPLACING THE LITHIUM BATTERY

The memories are retained through the use of a lithium battery. It is a type 2016 "coin cell" battery widely available as a calculator and camera replacement.

- 1 Remove the top cover. Be careful not to stress the speaker leads.
- 2 The lithium battery is clearly visible from the top near the back of the second PCB. See Fig. 7. It is a coin type about the size and shape of a nickel.
- 3 Use a small screwdriver to lift and slide out the old battery.

- Slide in the replacement. Make sure the side marked + is facing up.
- Replace the top cover.
- Hold in the MEM button while turning power on to restore the factory presets to the memory.

Figure 7: Lithium Battery (Top view, rear of unit)

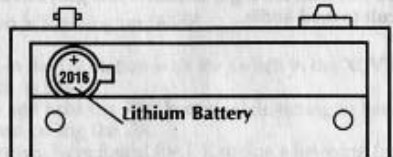

CALIBRATION

TRANSMITTER OUTPUT STAGE BIAS

Equipment Needed: Ammeter 0-2 amps connected to measure the current drawn from the 12V supply.

Adjust: Transmitter BIAS pot (R18) on XMTR PCB. (Bottom board on the stack) See Figure 17. The pot is accessible from the side of the board.

- Set the CW Power control to its lowest setting. (Fully Counter clockwise)
- Set the XMTR BIAS control (R18 on XMTR PCB) fully counter clockwise.
- Close key and read the current from the 12V supply.
- Adjust R18 (BIAS) to read a current 60MA higher.

S METER ZERO

Adjust: R31 on the AF PCB (3rd from bottom on the stack). See Figure 11. The pot is accessible from the side of the PCB. With no antenna connected, adjust R31 (S Meter Zero) for a reading of zero on the S meter.

SSB CARRIER NULL

Equipment Needed: A 30db resistive attenuator and a receiver with an S meter.

Adjust: RF PCB, Figure 13. Top PCB in stack. C9 and C10 trimmer capacitors.

- Connect the QRP PLUS antenna jack through the attenuator to the receiver antenna jack.
- Set the QRP PLUS and the receiver to the same frequency.
- Turn the CW Power control to its lowest setting (fully counterclockwise).
- Hold down the key and adjust the SSB carrier null trimmer capacitors (C9, C10) for minimum signal in the receiver.

The trimmers interact and must be adjusted patiently to obtain a sharp, deep null.

SYNTHESIZER REFERENCE FREQUENCY

Caution: The accuracy of the displayed frequency and correct tuning depend on the precision of this adjustment. We suggest you perform this adjustment only if necessary and work with particular care to ensure accuracy.

Equipment Needed: Frequency counter with 1HZ resolution, Signal Generator

Adjust: LO PCB, Second board from bottom of stack. See Figure 9, C47 and C48 trimmer capacitors

- Tune the QRP PLUS to 7.300.0 MHZ.
- Connect the frequency counter to U4 (MC145156) Pin 17 (located near the trimmer capacitors).
- Slowly turn the main tuning dial. The measured frequency should go from 4,000,312 HZ to 4,000,493 HZ then drop back to 4,000,312 HZ.

The jump occurs over a very small movement of the tuning dial. Practice until you can set the tuning to the closest point on either side of the frequency jump. Listening to a carrier from a signal generator can be helpful.

If the unit needs calibration, the trimmer capacitors should be set so that the two frequencies are 4,000,312 and 4,000,493 HZ. The capacitors interact and the adjustments must be made slowly to obtain accurate results.

CIRCUIT DESCRIPTION

The QRP PLUS uses a single conversion up converting design. The IF frequency is 50MHZ. Bidirectional circuitry is used in the IF and filter chain.

Selectivity is provided by a 6 pole crystal ladder filter at 50MHZ and variable SCAF digital filters at audio.

The synthesizer is a single loop design. The basic synthesizer uses 2KHZ steps with intermediate steps of approximately 10HZ obtained through direct microprocessor control of the reference.

RECEIVE (SEE BLOCK DIAGRAM FIG. 8)

An incoming signal is routed through the transmit/receive relay to the front panel attenuator. The attenuator can insert a 20DB resistive pad in the signal line. From the attenuator, the signal passes through a high pass and a low pass filter to the SBL-1 diode ring double balanced mixer. The mixer converts the incoming signal to an IF frequency of 50MHZ.

The synthesizer has three voltage controlled oscillators covering the following ranges:

42.7MHZ - 48.2MHZ
57.3MHZ - 68MHZ
68MHZ - 79.7MHZ

The lower range corresponds to incoming signals from 1.8MHZ to 7.3MHZ. The lower range is below the 50MHZ IF while the higher ranges are above the IF. In conjunction with the crystal filter this provides lower sideband operation below 7.3MHZ and upper sideband operation above 7.3MHZ.

The VCO's are selected under microprocessor control and the VCO output is buffered, amplified and applied to the balanced mixer.

The synthesizer uses a Motorola 145156 IC and a dual modulus prescaler. The reference frequency is 4MHZ. The synthesizer

uses 2KHZ steps. Intermediate steps of approximately 10HZ are provided by controlling the reference frequency with a D/A converter from the microprocessor. The microprocessor controls the synthesizer and D/A to provide smooth, continuous tuning across the frequency range.

The 50MHZ IF signal goes through a strong amplifier and an attenuator to a 6 pole crystal filter. The crystal filter is set to 2.4KHZ bandwidth and its principle function is to reject the opposite sideband. Overall receiver bandwidth and filter shape factor are established by the variable digital audio filters.

From the crystal filter the signal passes through a low noise preamplifier and a MC1350 IF amplifier which also provides AGC control. The product detector is an SBL-1 diode ring balanced mixer.

The signal is routed through an audio preamplifier to the SCAF digital filters, first the HPF then the LPF. The filter cutoff frequencies are set by the microprocessor. After filtering the signal is routed to both the audio output amplifier and the AGC amplifier.

The AGC amplifier has switching and storage functions to ensure smooth CW break in operation.

SSB TRANSMIT

The signal from the microphone is amplified by the mic preamp and applied to the gain controlled amplifier, an MC3340. The gain controlled amplifier uses transmitter derived automatic level control signal to limit the signal to the transmitter's linear range. The audio is then applied to the SSB balanced modulator. The balanced modulator uses the same BFO as is used in receive.

CW TRANSMIT

When the key is closed, the microprocessor performs all the switching functions with appropriate delays to ensure smooth break in operation. A voltage, set by the CW power control is applied to the SSB balanced modulator while the BFO frequency is shifted down 800HZ to the center of the passband. This creates a 50MHZ carrier whose level is set by the CW power control. From this point the CW and SSB signals follow the same path.

Also operating under microprocessor control are the sidetone and keyer functions.

The IF and mixer are bidirectional, that is, the transmit signal passes through the same stages in the reverse direction as the receive signal. First the crystal filter, the attenuator pad, a broadband amplifier, the SBL-1 mixer and the filters.

The remainder of the transmitter consists of four broadband gain stages building the signal to five watts output. The transmitter output stage is a power MOSFET followed by a bank of 6 low pass filters and the reed relay antenna switching circuit.

A panel meter reads AGC level in receive and relative RF output on transmit.

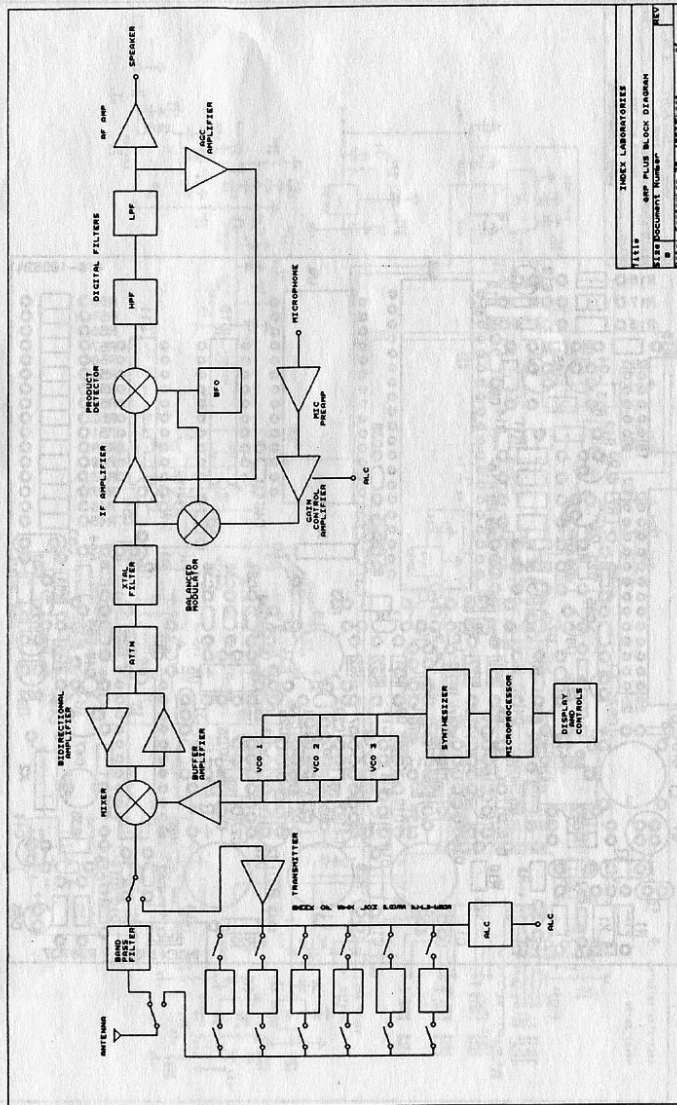

REV	9
DATE	01/11/81
DESIGNER	W. W. WILSON
APP. NO.	1000
PROJECT	INDEX LABORATORIES

FIGURE 8: BLOCK DIAGRAM

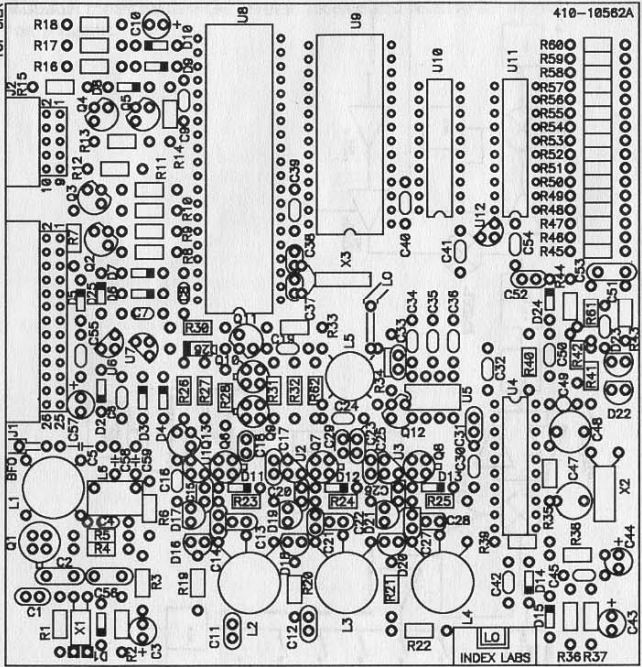

FIGURE 9: QRP-LO PCB ASSEMBLY

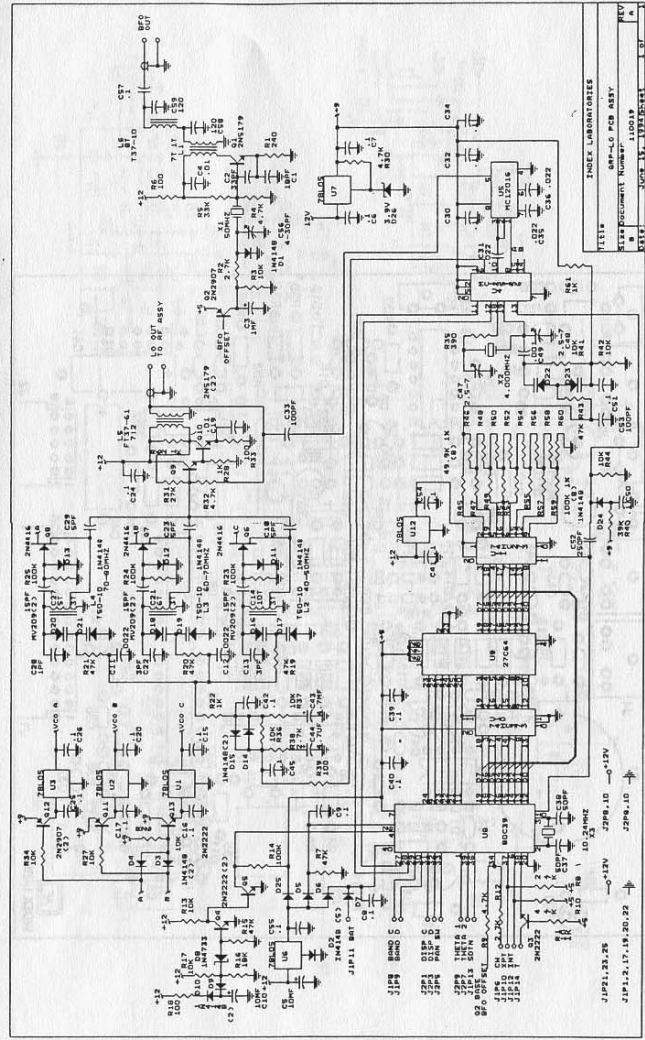

FIGURE 10: QRP-LO SCHEMATIC DIAGRAM

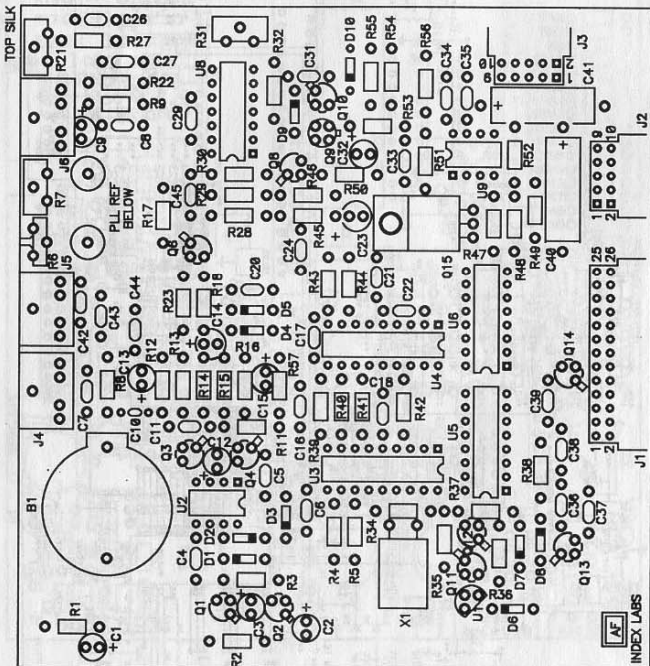

FIGURE 11: QRP-AF PCB ASSEMBLY

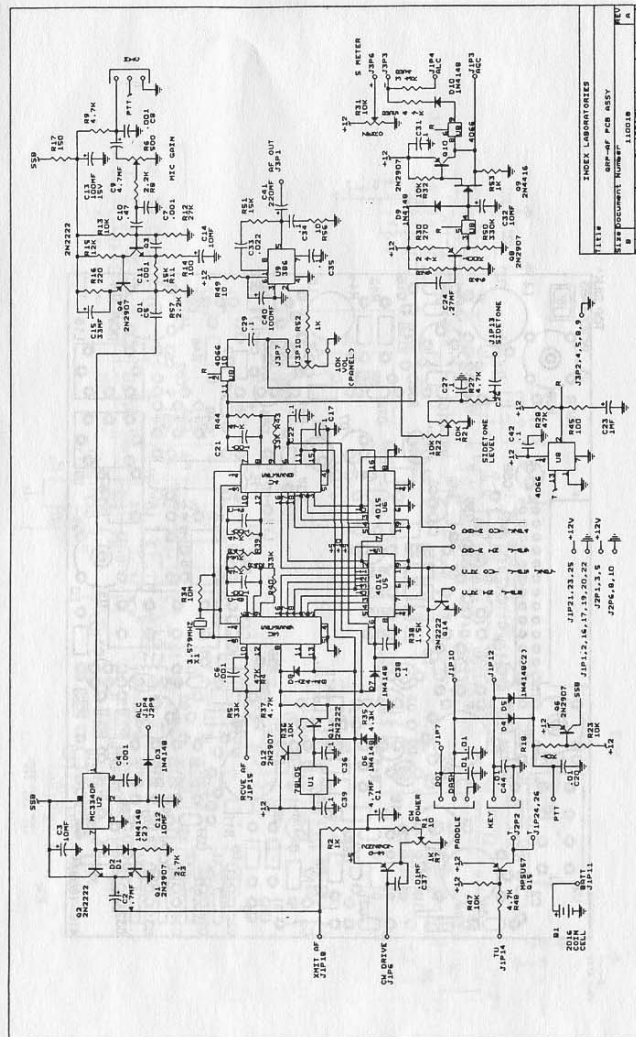

FIGURE 12: QRP-AF SCHEMATIC DIAGRAM

FIGURE 13: QRP-RF PCB ASSEMBLY

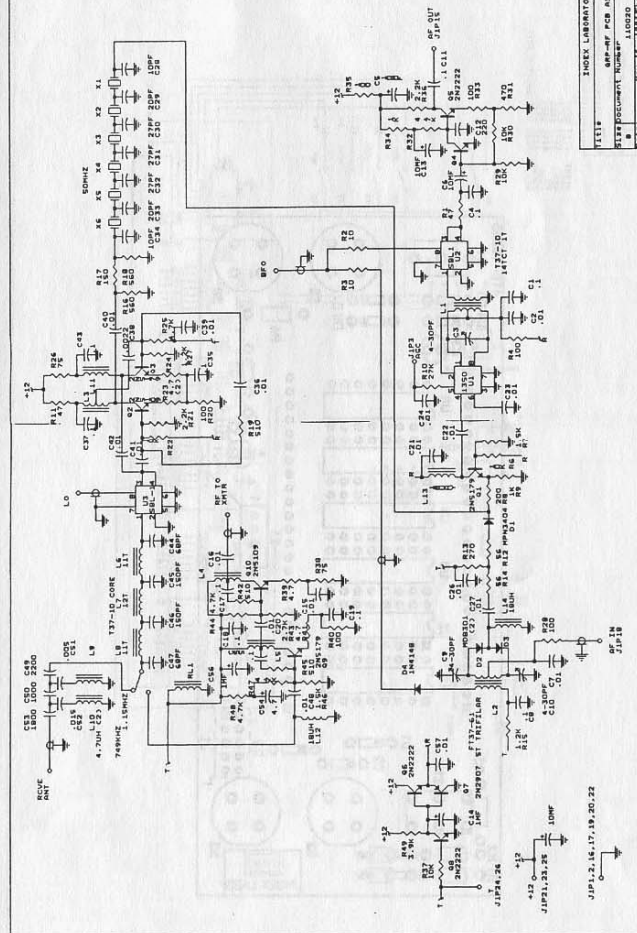
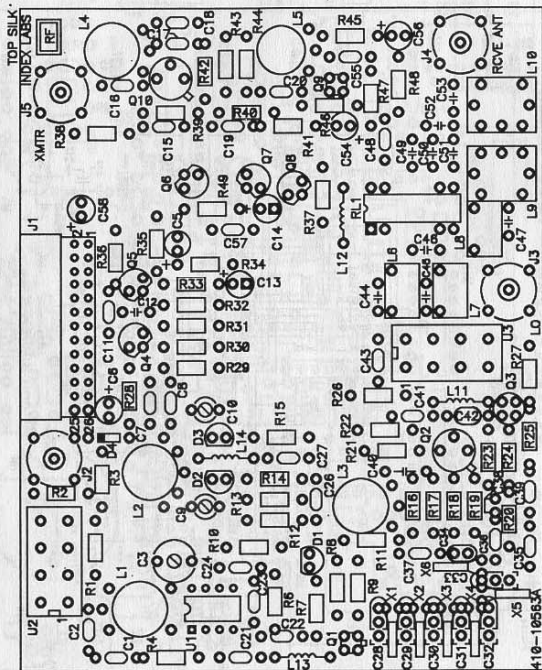

FIGURE 14: QRP-RF SCHEMATIC DIAGRAM

