PORTABLE FM TRANSIVER

Kydera[®] CDR-300UV

SERVICE MANUAL/维修手册



GENERAL/概述

INTRODUCTION

SCOPE OF THIS MANUAL

This manual is intended for use by experienced technicians familiar with similar types of commercial grade communications equipment. It contains all required service information for the equipment and is current as of the publication date. Changes which may occur after publication are covered by either Service Bulletins or Manual Revisions. These are issued as required.

ORDERING REPLACEMENT PARTS

When ordering replacement parts or equipment information, the full part identification number should be included. This applies to all parts: components, kits, or chassis. If the part number is not known, include the chassis or kit number of which it is a part, and a sufficient description of the required component for proper identification.

PERSONAL SAFETY

The following precautions are recommended for personal safety:

- DO NOT transmit until all RF connectors are verified secure and any open connectors are properly terminated.
- SHUT OFF and DO NOT operate this equipment near electrical blasting caps or in an explosive
- This equipment should be serviced by a qualified technician only.

SERVICE

This radio is designed for easy servicing. Refer to the schematic diagrams, printed circuit board views, and alignment procedures contained within.

Number of channels	RF Power Output
255	15W

引言

本手册的范围

本手册是提供给熟悉通信专业并且具有维修经验的技术人员使用的。它包括了维修该设备所需要的全部资料和现行公布的数据。在出版后可能发生变动，如果需要，可以使用《维修通报》或《手册修订本》进行补充。

替换零件的订购

当订购替换零件或设备信息时，应注明完整的零件识别号码。所有的零件均有识别号码：元件、组件或机壳。如果不知道零件的号码，为了正确地识别，必须注明此元件所属的机壳或组件的号码，并对元件进行充分的说明。

个人安全

为了个人的安全，请注意下列事项：

- 在没有认真核实所有射频插头之前或有任何一个打开的插头没有连接到响应端子上的情况下，均不要发射。
- 在电爆管附近或在易燃性气体环境中，必须关掉电源，不要操作本设备
- 本设备只应该由有资格的技术人员来维修。

维修服务

为了便于维修本设备，建立了完整的维修服务体系，提供了包括原理图、印刷线路图和调整步骤在内的资料供参考。

信道数量	射频输出功率
255	15W

MODES

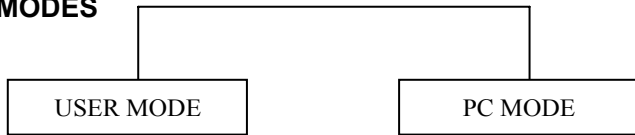

MODES	FUNCTION
User mode	For normal use.
PC mode	Used for communication between the radio and a PC

How to enter each mode

MODES	PROCEDURE
User mode	Power ON
PC mode	Receiver commands from PC

PC MODE

Preface

The CDR-300VU transceiver can be programmed using a personal computer, A programming interface cable and programming software. The programming software can be used on an IBM PC or compatible. Fig-1 shows the setup of a PC for programming.

Caution:

When removing or installing the programming cable, first switch off the radio power.

Additionally, be sure to disable the VOX function, if it's enabled, as it can sometimes activate from connection noise.

Connection procedure

1. Connect the CDR-300VU to the personal Computer using the interface cable.
2. When the POWER is switched ON, you can enter user mode.

Programming software description

The software allows a user to program the CDR-300VU radios via the programming interface cable.

• Programming with IBM PC

If data is transferred to the transceiver from a PC with the software, the destination data (basic radio information) for each set can be modified.

模式

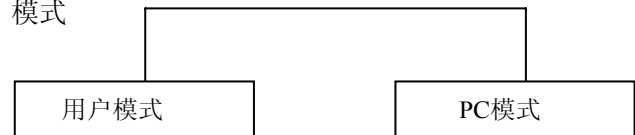

模式类型	功能
用户模式	用于普通操作
计算机模式	Used for communication between the radio and a PC

模式类型	操作步骤
用户模式	打开电源开关
计算机模式	从计算机接收命令

计算机模式

前言

通过个人电脑，使用编程电缆和编程软件，对对讲机CDR-300VU进行编程设置。图1表示一台IBM计算机的编程设置过程。

注意

当拔除或者插入编程电缆首先关闭对讲机电源。另外，确保声控功能已关闭，如果声控被激活，可能有时会开启连接噪音。

连接步骤

1. 使用接口电缆将CDR-300VU与个人电脑连接。
2. 当电源开关打开，可以进入用户模式。

编程软件说明

该软件允许用户经由编程接口电缆对CDR-300VU进行编程设定。

使用IBM计算机编程

如果从使用软件的IBM计算机将数据发送到手持机，设定的数据（基本通信参数）均可被修改。

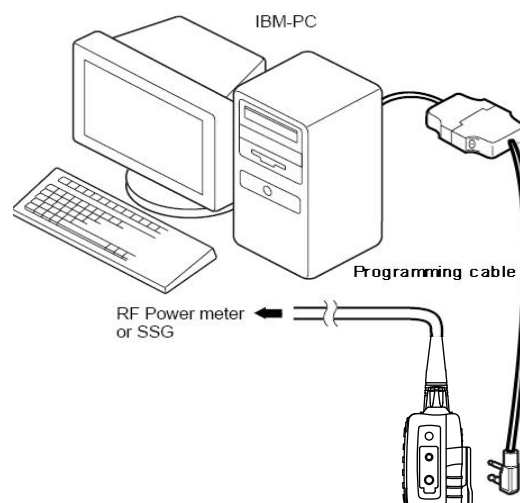

电路说明

1. 接收部分

a) 前级（射频放大器）

从天线输入的接收信号经低通，经过二极管收发转换电路，在射频放大器 Q3, Q4 被放大，其中 V 段线圈 L28, L30, L32, L16, L20 构成选频带通；U 段线圈 L15, L17, L21 构成选频带通，通过开关 A3 选择进入 Q14 混频

b) 混频

来自射频放大器的信号与来自 U5(WX4818) 的第一本振信号在 Q14 中混频，并产生 51.550MHZ 的第一中频信号。

c) 中频、静噪、音频

第一中频信号进入芯片 U1 (FD6818)
模拟信道：经过开关 U38 输出到功放。
数字信道：FD6818 输出到 U1 (C7000) 进行信号解码，解压并处理转换成数字信号，并输出送入音频放大。

CIRCUIT DESCRIPTION

1. RECEIVER

a) Front Amplifier(RF AMP)

The signal coming from the antenna input via the low-pass, through the diode transceiver conversion circuit, is amplified by the RF amplifiers Q3 and Q4. Among them, the V-section coils L28, L30, L32, L16, and L20 constitute the selective band pass; the U-section coils L15, L17, L21 constitutes a selective band pass, and selects into Q14 mixing through switch A3

b) Mixing

The signal from the RF amplifier is mixed with the first local oscillator signal from U5 (WX4818) in Q14, and generates a first intermediate frequency signal of 51.550 MHz.

c) IF (Intermediate Frequency),

Squelch, Audio

The first intermediate frequency signal enters chip U1 (FD6818)
Analog channel: output to the power amplifier through switch U38.
Digital channel: FD6818 output to U1 (C7000) for signal decoding; decompression lamp processing is converted into digital signal, and the output is sent to audio for amplification.

2. 发射部分

a) 发射音频

信号有话筒产生

模拟信道：送入到 FD6818 进行调频等处理后输出。

数字信道：送入基带处理器 C7000 进行采样、编码、压缩、I/Q 调制输出到 FD6818 进行调频等处理后输出

b) CTCSS DCS

CTCSS DCS 亚音频的编码可由微处理器产生，在 IC 内置 VCO 进行调制。

c) VCO 及射频放大器

通过编程控制 FD6818 完成频率的自动控制
FD6818 输出的射频信号在 Q5 被放大后，经过开关 A1 切换选择 VU

U: 信号经过 Q3 放大后，达到末级功率放大器所需的激励电平。

V: 信号经过 Q7, Q1 放大后，达到末级功率放大器所需的激励电平

d) 末级功率放大器

U 段功率放大器采用 MOS FET 末级功率放大器 Q4

V 段功率放大器采用 MOS FET 末级功率放大器 Q2

2. Transmitter

a) Transmitter audio

The signal is generated by microphone

Analog channel: sent to FD6818 for frequency modulation and other processing, then sent out

Digital channel: sent into the baseband processor C7000 for sampling, encoding, compressing, I/Q modulation and then output to FD6818 for frequency modulation and other processing, finally send out.

b) CTCSS DCS

CTCSS,DCS encoding can be generated by the microprocessor and modulated by the IC's built-in VCO.

c) VCO and RF amplifier

The automatic frequency control is completed by programming control FD6818. After the RF signal output by FD6818 is amplified in Q5, it is switched to VU via A1 switch.

U: After the signal is amplified by Q3, it reaches the excitation level required by the final power amplifier

V: After the signal is amplified by Q7 and Q1, it reaches the excitation level required by the final power amplifier

d) Final power amplifier

U: The amplifier adopts MOS FET final power module Q4.

V: The amplifier is adopted MOS FET type power module Q3.

e) 天线转换开关和 LPF

U 段时：末级功率放大器输出的信号经过 D5 和由 L14, L22, L25, L23, L17 组成带通滤波器后从天线端子发射出去。

D5, D10 一起构成了收发转换开关。

V 段时：末级功率放大器输出的信号经过 D9 和由 L9, L10, L12, L33, L21, L27 组成低通滤波器后从天线端子发射出去。D9, D2 一起构成了收发转换开关

e) ANT switch and LPF

U: The signal output by final power amplifier passes through diodes D5 and is composed of L14, L22, L25, L23 and L17 to form a band pass filter and then is transmitted from antenna terminal. D5 and D10 are consist of TR switch

V: The signal output by final power amplifier passes through diodes D9 and is composed of L9, L10, L12, L33, L21 and L27 to form a low-pass filter and then is transmitted from antenna terminal. D9 and D2 are consist of TR switch

3. 自动功率控制电路

自动功率控制电路，通过检测末级放大器场效应管的漏极电流来稳定发射输出功率。电压比较电路 U1 用微处理器设定的参考电压来比较末级电流所获得的电压。自动功率控制电压与 U1 输出的自动检测减压和参考电压之前的差值成正比。此输出电压控制场效应管功率放大器，保持发射部输出功率常数。发射部输出功率可以通过微处理器进行改变，在微处理器中改变参考电压来控制输出功率。

3. Automatic power control circuit

The automatic power control circuit stabilizes the transmitted output power by detecting the drain current of the final amplifier FET. The voltage comparison circuit U1 uses the reference voltage set by the microprocessor to compare the voltage obtained by the final stage current. The automatic power control voltage is proportional to the difference between the U1 output auto-detection decompression and the reference voltage. This output voltage controls the field effect tube power amplifier to maintain the output power constant of the transmitter. The output power of the transmitter can be changed by a microprocessor, and the reference voltage is changed in the microprocessor to control the output power.

4. 电源

电源通过 Q24, Q25 组成的开关电路后再经过稳压 IC 得到 8V，各个电路所需要的 5V, 3.6V, 3.3V 电源

4. Power Supply

The power supply passes through the switch circuit composed of Q24 and Q25 and then passes through the voltage regulator IC to obtain 8V. The 5V, 3.6V and 3.3V power required by each circuit

5. 控制系统

U1 微处理器以 24MHZ 工作

6. 音频放大器

模拟信号由 FD6818 9 脚输出，数字信号由 C7000 输出，再由音频功率放大器 U4, (SA58632) 放大后驱动扬声器。

7. 接收信令 (CTCSS DCS)

从 FD6818 第 32 脚出来的 CTCSS, DCS 经过微处理器 U1 (C7000) 出处理，微处理器根据内部的各种处理判断接收的亚音频是否与预先设定的值一致，其判断结果和噪声、静噪的判断结果一起控制 MUTE 及 AFCO，由此控制扬声器输出。

8. 锁相环

接收和发射的压控控制振荡器是在 FD6818 内集成的，锁相控制由编程控制。基准振荡器由外部温补晶体 26M 振荡信号。通过晶振的可调端来校准 VCO 频率

5. Control system

U1 microprocessor works at 24MHZ.

6. Audio amplifier

The analog signal is output thru pin 9 of FD6818, and the digital signal is output by C7000, and then amplified by audio power amplifier U4 (SA58632) to drive the speaker.

7. Receive signaling (CTCSS DCS)

The CTCSS and DCS coming out from the 32nd pin of FD6818 are processed by the microprocessor U1 (C7000). The microprocessor judges whether the received sub-audio is consistent with the preset value according to various internal processes. The judgment result together with judgment results of noise and squelch to control MUTE and AFCO, thereby controlling the speaker output.

8. PLL (Phase locked loop)

The VCO of receiving and transmitting is integrated in FD6818, and the PLL is controlled by programming. The reference oscillator consists of an external temperature compensation crystal 26M oscillation signal, and the VCO frequency is calibrated through the adjustable end of the crystal.

FD6818 芯片的引脚功能

1	AVDD	Power supply	电源
2	SCLK	Clock input for serial control bus	时钟线
3	SDIO	Data input/output for serial control bus	数据线
4	AVDD	Power supply	电源
5	XTAL1	Oscillator pin1	晶体引脚
6	XTAL2	Oscillator pin2	晶体引脚
7	MODE	Control interface select	控制接口的选择
8	SENB	Latch enable(active low) input for serial control bus	置位
9	AF-OUT	Audio signal output to speaker	音频输出
10	NC	No connection	NC
11	MIC_IN	MIC input	话筒输入
12	Cc	Compensation capacitor connection pin	补偿电容
13	AVDD	Power supply	电源
14	NC	No connection	NC
15	RFIN	RF signal input	射频信号输入
16	AVDD	Power supply	电源
17	NC	No connection	NC
18	RFOUT	RF signal output	射频信号输出
19	NC	No connection	NC
20	NC	No connection	NC
21	AVDD	Power supply	电源
22	PABIAS	PA bias supply for PA	悬空
23	AVDD	Power supply	电源
24	PDN	Chip enable, low active	省电功能
25	G7/VOX	Gpio7/vox	悬空
26	G6/SQ	Gpio7/sq	静噪功能
27	G5/TXON	Gpio7/txon	发射电源控制(高电平有效)
28	G4/RXON	Gpio7/rxon	接收电源控制(高电平有效)
29	G3/SDIO	Gpio7/sdo	悬空
30	G2/INT	Gpio7/int	FD6818 中断控制
31	G1/CODE	Gpio7/code	悬空
32	G0/CSS	Gpio7/css	CT/DCSS

PARTS LIST/零件表

CAPACITORS

CC 45 TH 1H 220 J

1 2 3 4 5 6

1=Type...ceramic,electrolytic,etc.

2=Shap...round,square,ect.

3=Temp.coefficient

4=Voltage rating

5=Value

6=Tolerance

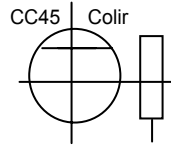

.Caocitor value

010=1pF

100=10pF

101=100pF

102=1000pf=0.001uF

103=0.01uF

2 2 0=22pF

Multiplier

2nd number

1st number

.Temperature coeffictrolytict

1st Word	C	L	P	R	S	T	U
Color	Black	Red	Orange	Yellow	Green	Blue	Violet
ppm/°C	0	-80	-150	-220	-330	-470	-750

2nd Word	G	H	J	K	L
ppm/°C	±30	±60	±120	±250	±500

Example:CC45TH=-470 ±60ppm/°C

.Tolerance (More than 10pF)

Code	C	D	G	J	K	M	X	Z	P	No code
(%)	±0.25	±0.5	±2	±5	±10	±20	±40	+80 -20	100 0	More than 10uF-10~+50 Less than 4.7uF-10~+75

Less than 10pF)

Gode	B	C	D	F	G
(pF)	±0.1	±0.25	±0.5	±1	±2

.Voltage rating

1st word	2nd word	A	B	C	D	E	F	G	H	J	K	V
0		1.0	1.25	1.6	2	2.5	3.15	4	5	6.3	8	-
1		10	12.5	16	20	25	31.5	40	50	63	80	35
2		100	125	160	200	250	315	400	500	630	800	-
3		1000	1250	1600	2000	2500	3150	400	5000	6300	8000	-

.Chip capacitors

(EX)

CC 73 F SL 1H 000 J

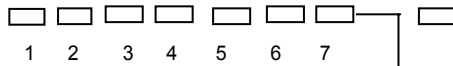

(Chip)(CH,RH,UJ,SL)

- 1=Type
- 2=Shap
- 3=Dimension
- 4=Temp.coefficient
- 5=Voltage rating
- 6=Value
- 7=Tolerance

(EX)

CK 73 F F 1H 000 Z

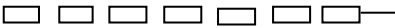

(Chip)(B,F)

Dimension(capacitors)

Dimension code	L	W	T
Empty	5.6±0.5	5.0±0.5	Less than 2.0
A	4.5±0.5	3.2±0.4	Less than 2.0
B	4.5±0.5	2.0±0.3	Less than 2.0
C	4.5±0.5	1.25±0.2	Less than 1.25
D	3.2±0.4	2.5±0.3	Less than 1.5
E	3.0±0.2	1.6±0.2	Less than 1.25
F	2.0±0.3	1.25±0.2	Less than 1.25
G	1.6±0.2	0.8±0.2	Less than 2.0
H	1.0±0.05	0.5±0.05	0.5±0.05

RESISTORS

.Chip resistor(Carbon)

(EX)

RD 73 E B 2B 000 J

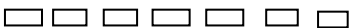

(Chip)(B,F)

.Carbon resistor(Normal type)

(EX)

RD 14 B B 2C 000 J

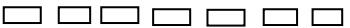

1=Type

2=Shap

3=Dimension

4=Temp.coefficient

5=Rating wattage

6=Value

7=Tolerance

INDUCTANCE

LD 73 B B 000 G



1=Type

2=Shap

3=Dimension

4=Temp.coefficient

5=Value

6=Tolerance

Dimension

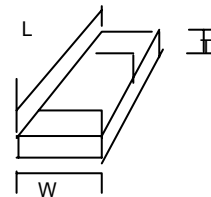

Dimension(Chip resistor)

Dimension code	L	W	T
E	3.2±0.2	1.6±0.2	1.0
F	2.0±0.3	1.25±0.2	1.0
G	1.6±0.2	0.8±0.2	0.5±0.1
H	1.0±0.05	0.5±0.05	0.35±0.05

Rating wattage

Code	wattage	code	wattage	code	wattage
1J	1/16W	2C	1/6W	3A	1W
2A	1/10W	2E	1/4W	3D	2W
2B	1/89W	2H	1/2W		

型号：CDR-300UV

MCU 电子部份

序号 NO.	材料名称 Type Name	器件编号 Parts No.	规格描述			用量	位置	备注 Remark	应发 数量
			Description				Standard		
1	主板	100-DR200MFD-300	C7DR300UV-MCU-FD-51M-2.0			1			
2	Resistor	104-11040RXX-J00	0R	0402	±5%	35	R474 R473 R92 R90 R89 R7 R26 R158 R138 R137 R131 R126 R125 R119 R118 R117 R15 R721 R23 C255 R472 R471 R91 R10 R297 R170 R167 R162 R159 R155 C185 C184 R99 R153 R116		
3	Resistor	104-110410RX-J00	10R	0402	±5%	2	R174 R397		
4	Resistor	104-110433RX-J00	33R	0402	±5%	19	R9 R83 R82 R81 R80 R8 R1 R4 R5 R11 R12 R13 R87 R86 R85 R84 R2 R3 R14		
5	Resistor	104-1104100R-J00	100R	0402	±5%	2	R77 R152		
6	Resistor	104-1104270R-J00	270R	0402	±5%	4	R135 R134 R133 R132		
7	Resistor	104-11041KXX-J00	1K	0402	±5%	6	R139 R6 R235 R70 R71 R169		
8	Resistor	104-11042KXX-J00	2K	0402	±5%	2	R88 R74		
9	Resistor	104-11042K2X-J00	2.2K	0402	±5%	1	R136		
10	Resistor	104-11044K7X-J00	4.7K	0402	±5%	4	R35 R34 R160 R164		
11	Resistor	104-11045K6X-J00	5.6K	0402	±5%	1	R168		
12	Resistor	104-110410KX-J00	10K	0402	±5%	15	R190 R112 R110 R109 R108 R106 R104 R102 C35 R72 R234 R237 R73 R157 R107		
13	Resistor	104-110412KX-J00	12K	0402	±5%	2	R111 R105		
14	Resistor	104-110420KX-J00	20K	0402	±5%	1	R130		
15	Resistor	104-110433KX-J00	33K	0402	±5%	2	R145 R143		
16	Resistor	104-110447KX-J00	47K	0402	±5%	2	R166 R165		
17	Resistor	104-110456KX-J00	56K	0402	±5%	2	R147 R146		
18	Resistor	104-1104100K-J00	100K	0402	±5%	9	R31 R30 R28 R27 R79 R78 R129 R114 C121		
19	Resistor	104-1104470K-J00	470K	0402	±5%	4	R173 R172 R163 R161		
20	Capacitor	105-11049PXX-C10	9P/50V	0402	±0.25%	2	C68 C66		
21	Capacitor	105-110410PX-J10	10P/50V	0402	±5%	1	C113		
22	Capacitor	105-110422PX-J10	22P/50V	0402	±5%	2	C183 C182		
23	Capacitor	105-110468PX-J10	68P/50V	0402	±5%	1	C194		
24	Capacitor	105-1104100P-J10	100P/50V	0402	±5%	7	C253 C399 C258 C196 C291 C198 C189		
25	Capacitor	105-1104470P-J10	470P/50V	0402	±5%	2	C250 R179		
26	Capacitor	105-1104102P-K10	102P/50V	0402	±10%	6	C37 C115 C106 C354 C200 C188		

型号：CDR-300UV

MCU 电子部份

序号 NO.	材料名称 Type Name	器件编号 Parts No.	规格描述			用量	位置	备注 Remark	应发 数量
			Description				Standard		
1	主板	100-DR200MFD-300	C7DR300UV-MCU-FD-51M-2.0			1			
2	Resistor	104-11040RXX-J00	0R	0402	±5%	35	R474 R473 R92 R90 R89 R7 R26 R158 R138 R137 R131 R126 R125 R119 R118 R117 R15 R721 R23 C255 R472 R471 R91 R10 R297 R170 R167 R162 R159 R155 C185 C184 R99 R153 R116		
3	Resistor	104-110410RX-J00	10R	0402	±5%	2	R174 R397		
4	Resistor	104-110433RX-J00	33R	0402	±5%	19	R9 R83 R82 R81 R80 R8 R1 R4 R5 R11 R12 R13 R87 R86 R85 R84 R2 R3 R14		
5	Resistor	104-1104100R-J00	100R	0402	±5%	2	R77 R152		
6	Resistor	104-1104270R-J00	270R	0402	±5%	4	R135 R134 R133 R132		
7	Resistor	104-11041KXX-J00	1K	0402	±5%	6	R139 R6 R235 R70 R71 R169		
8	Resistor	104-11042KXX-J00	2K	0402	±5%	2	R88 R74		
9	Resistor	104-11042K2X-J00	2.2K	0402	±5%	1	R136		
10	Resistor	104-11044K7X-J00	4.7K	0402	±5%	4	R35 R34 R160 R164		
11	Resistor	104-11045K6X-J00	5.6K	0402	±5%	1	R168		
12	Resistor	104-110410KX-J00	10K	0402	±5%	15	R190 R112 R110 R109 R108 R106 R104 R102 C35 R72 R234 R237 R73 R157 R107		
13	Resistor	104-110412KX-J00	12K	0402	±5%	2	R111 R105		
14	Resistor	104-110420KX-J00	20K	0402	±5%	1	R130		
15	Resistor	104-110433KX-J00	33K	0402	±5%	2	R145 R143		
16	Resistor	104-110447KX-J00	47K	0402	±5%	2	R166 R165		
17	Resistor	104-110456KX-J00	56K	0402	±5%	2	R147 R146		
18	Resistor	104-1104100K-J00	100K	0402	±5%	9	R31 R30 R28 R27 R79 R78 R129 R114 C121		
19	Resistor	104-1104470K-J00	470K	0402	±5%	4	R173 R172 R163 R161		
20	Capacitor	105-11049PXX-C10	9P/50V	0402	±0.25%	2	C68 C66		
21	Capacitor	105-110410PX-J10	10P/50V	0402	±5%	1	C113		
22	Capacitor	105-110422PX-J10	22P/50V	0402	±5%	2	C183 C182		
23	Capacitor	105-110468PX-J10	68P/50V	0402	±5%	1	C194		
24	Capacitor	105-1104100P-J10	100P/50V	0402	±5%	7	C253 C399 C258 C196 C291 C198 C189		
25	Capacitor	105-1104470P-J10	470P/50V	0402	±5%	2	C250 R179		
26	Capacitor	105-1104102P-K10	102P/50V	0402	±10%	6	C37 C115 C106 C354 C200 C188		
27	Capacitor	105-1104103P-K10	103P/50V	0402	±10%	9	C252 C249 C3 C169 C168 C167 C166 C150 C181		
28	Capacitor	105-1104473P-K10	473P/50V	0402	±10%	2	C210 C4		

29	Capacitor	105-1104104P-K10	104P/16V	0402	±10%	39	C240 C239 C77 C31 C22 C19 C177 C158 C148 C143 C138 C123 C12 C117 C112 C100 C99 C94 C92 C29 C28 C27 C26 C25 C20 C13 C120 C116 C103 C102 C207 C213 C7 C197 C193 C180 C122 C238 C156		
30	Capacitor	105-1104105P-K10	105P/10V	0402	±10%	21	C46 C45 C36 C170 C160 C157 C155 C147 C146 C145 C134 C133 C296 C161 C8 R156 C195 C192 C190 C162 C38		
31	Capacitor	105-1104225P-K20	225P/16V	0402	±10%	4	C97 C95 C79 C101		
32	Resistor	104-11060RXX-J00	0R	0603	±5%	1	FB26		
33	Resistor	104-11080RXX-J00	0R	0805	±5%	1	L5		
34	RTO-A	104-11065K1X-F00	5.1K*	0603	±5%	1	R120		
35	Resistor	104-110610KX-J00	10K	0603	±5%	2	R121 R238		
36	RTO-A	104-110647KX-F00	47K*	0603	±5%	1	R124		
37	Resistor	104-11123K6X-J00	3.6K	1206	±5%	2	R236 R239		
38	Capacitor	105-1106470P-J10	470P/50V	0603	±10%	1	C2946		
39	Capacitor	105-1106104P-K10	104P/50V	0603	±10%	3	C137 C294 C293		
40	Capacitor	105-1108102P-J10	102P/50V	0805	±10%	1	C292		
41	TAIY	107-12063N9X-J00	3.9NHL	0603		1	C186		
42	TAIY	107-12065N6X-J00	5.6NHL	0603		1	L6		
43	Magnetic bead ind	107-1304220R-M10	220R@100MHZ	0402		3	FB6 FB5 FB27		
44	Magnetic bead ind	107-1306600R-M10	600R@100MHZ	0603	±10%	10	FB25 FB24 FB23 FB22 FB21 FB20 FB17 FB14 FB13 FB10		
45	Magnetic bead ind	107-130830RX-M30	BLM21PG300SN1D	0805	±10%	1	B2		
46	Power inductance	107-17A64U7X-M00	SWPA3012S4R7MT	2828	±1%	2	L4 L2		
47	Polarized electro	106-116C100U-M30	100UF/10V	1206C	±20%	3	C179 C178 C43		
48	Non-polarized ele	106-13081UXX-K20	1UF/16V	0805	±20%	4	C159 C152 C151 C187		
49	Non-polarized ele	106-13084U7X-K30	4.7UF/10V	0805	±20%	1	C144		
50	Non-polarized ele	106-130810UX-K30	10UF/10V	0805	±20%	16	E9 E7 C91 C33 C165 C164 C149 C142 C141 C140 C132 C125 C83 E8 E13 C199		
51	Non-polarized ele	106-130822UX-K30	22UF/10V	0805	±20%	3	C154 C124 C118		
52	Non-polarized ele	106-130847UX-K30	47UF/10V	0805	±20%	2	C39 C30		
53	Super Capacitor	105-17A3C005-C10	DMS3R3304			1	C32		
54	Patch diode	102-11SS314U-080	KDS114E/UD	0805		2	D1 D2		
55	Patch diode	102-11N4148X-060	IN4148WT	SOD-523	0603	6	D39 D41 D6 D5 D8 D7		
56	SMT triode	103-1TC144EE-090	DTC144EE	SOT-523		3	Q11 Q10 Q8		
57	SMT triode	103-1SC4617T-090	2SC4617			1	Q25		
58	SMT triode	103-12SK3065-080	2SK3065			2	Q13 Q12		
59	SMT IC	101-1S4157DF-250	NLAS4157DFT2G	SC70		1	U38		
60	SMT IC	101-1D25Q16C-210	GD25Q16CEIG	USON8 (3*2MM)		1	U12		
61	SMT IC	101-158632BS-100	SA58632BS	HVQFN20		1	U4		
62	SMT IC	101-1M721XN5-120	SGM721XN5/TR	SOT23-5		1	U43		
63	Memorizer	101-158CVG1S-310	TC58CVG1S3HRA IGBAJ	WSO8	容量:2G	1	U7		

64	SMT IC	101-104B332M-120	XC6204B332MR	SOT23-5		4	U37 U36 U35 U13		
65	SMT IC	101-104B502M-120	XC6204B502MR	SOT23-5		6	U34 U33 U32 U31 U18 U17		
66	SMT IC	101-18121ABC-120	SY8121ABC	SOT-23L		1	U30		
67	SMT IC	101-1AT2659X-000	AT2659			1	U42		
68	GPS module	101-15N71XXX-000	5N71			1	U41		
69	SMT IC	101-1HRV3000-120	ALPU-MP	SOT-23L		1	U10		
70	SMT IC	101-1HRC7000-000	C7000			1	U1		
71	Power chip	101-1562201D-120	TPS562201	MSOP10		1	U20		
72	Crystal	110-124MXX00-050	4MHz DSB321SC	S03225		1	X4		
73	Crystal	110-132K7603-000	32.768K	S3215	FC-135	1	X2		
74	Fuse3131	124-1000V1A5-000	150F-2	1206		1	F1		
75	20-pin horizontal	122-12005020-000	20PIN (MCU-LCD-UP)	0.5-20P	下接	1	J5041		
76	40-pin horizontal	122-11005040-000	40PIN		上接	1	J9121		
77	High power resist	104-1700220K-J00	GAOYA220K	插件	高压	1	D40		
78	Plug-in electroly	106-24K4100U-M60	100UF/25V	5*11	±20%	1	C297		
79	Plug-in electroly	106-24K6220U-M60	220UF/25V	8*12	±20%	1	C11		
80	Plug-in electroly	106-24P4470U-M60	470UF/25V	10*10	±20%	1	C104		
81	Plug-in triode	103-2B546AXX-020	B546	TO-92		1	Q24		
82	8-pin network soc	130-5224038P-120	522403-8P8C-1*1全包			1	JP1		
83	M18channel switch	109-03M18XXX-070	ED09D12M-FB14C8.0-C10-202			1	VR2		
84	RF antenna connec	130-JE02XXX1-000	一代板端 JE-02			1	J3(GPS_ANT)(GPS)		

TFT板 电子部份

序号 NO.	材料名称 Type Name	器件编号 Parts No.	规格描述 Description			用量	位置 Standard	备注 Remark	应发数量
1	TFT显示板	100-DR300TFT-300	C7DR300UV-TFT-51M-FD-2.0 2020.08.21			1	4拼阴阳板 有拼版文件可量间距	双层板	
2	Resistor	104-11040RXX-J00	0R	0402	±5%	10	R142 R145 R146 R147 R148 R149 R172 R173 R174 D6		
3	Resistor	104-1104100R-J00	100R	0402	±5%	3	R22 R21 R38		
4	Resistor	104-1104220R-J00	220R	0402	±5%	2	R9 R11		
5	Resistor	104-1104270R-J00	270R	0402	±5%	3	R15 R14 R13		
6	Resistor	104-1104910R-J00	910R	0402	±5%	2	R12 R1		
7	Resistor	104-11041KXX-J00	1K	0402	±5%	4	R30 R201 R19 R20		
8	Resistor	104-110410KX-J00	10K	0402	±5%	1	R2		
9	Resistor	104-110447KX-J00	47K	0402	±5%	3	R18 R16 R17		
10	Capacitor	105-1104100P-J10	100P/50V	0402	±5%	6	C22 C20 C19 C18 C21 C17		
11	Capacitor	105-1104103P-K10	103P/50V	0402	±5%	1	C239		
12	Capacitor	105-1104104P-K10	104P/16V	0402	±5%	2	C179 C238		
13	Capacitor	105-1104105P-K10	105P/10V	0402	±10%	3	C178 C210 C211		
14	SMT triode	103-1TC144EE-090	DTC144EE			2	Q3 Q2		
15	SMT triode	103-12SC4919-000	2SC4919			1	Q1		
16	SMT IC	101-104B182M-120	XC6204B182MR	SOT23-5		1	U3		
17	Green LED	118-10806210-000	G LED	0603		1	D11		
18	Red LED	118-10206211-000	R LED	0603		1	D111		
19	White LED	118-10106210-000	白灯	0603		6	D9 D7 D5 D3 D10 D1		
20	20-pin horizontal	122-12005020-000	20PIN(LCD)			1	J504		
21	PTT switch	115-1TS1188E-200	TS-1188E	3*6*3.5	200G	7	SW8 SW3 SW2 SW6 SW7 SW4 SW5		
22	LCD module	120-2X177A14-000	WX177A14 1.77寸TFT			1	J2		

Transmitter PACBA发射板 电子部份

序号 NO.	材料名称 Type Nam	器件编号 Parts No.	规格描述			用量	位置	备注	应发
			Description				Standard	Remark	数量
1	TX双功率	100-DR200TXX-400	C7DR300UV-TX-51M-FD-4.0 2021.04.12			1		四层板	
2	Resistor	104-11040RXX-J00	0R	0402	±5%	4	R36 R35 R25 R57		
3	Resistor	104-110410RX-J00	10R	0402	±5%	1	R26		
4	Resistor	104-110422RX-J00	22R	0402	±5%	1	C131		
5	Resistor	104-110447RX-J00	47R	0402	±5%	3	R14 R37 R56		
6	Resistor	104-1104100R-J00	100R	0402	±5%	3	R19 R33 R39		
7	Resistor	104-11041KXX-J00	1K	0402	±5%	8	R9 R3 R11 R64 R18 R144 R15 R41		
8	Resistor	104-11041K5X-J00	1.5K	0402	±5%	2	R8 R6		
9	Resistor	104-11042K2X-J00	2.2K	0402	±5%	1	R2		
10	Resistor	104-110410KX-J00	10K	0402	±5%	2	R38 C74		
11	Resistor	104-110415KX-J00	15K	0402	±5%	3	R7 R59 R58		
12	Resistor	104-110418KX-J00	18K	0402	±5%	1	R5		
13	Resistor	104-110424KX-J00	24K	0402	±5%	1	R10		
14	Resistor	104-110439KX-J00	39K	0402	±5%	1	R42		
15	Resistor	104-110456KX-J00	56K	0402	±5%	2	R13 R34		
16	Resistor	104-110468KX-J00	68K	0402	±5%	2	R32 C12		
17	Resistor	104-110491KX-J00	91K	0402	±5%	2	R27 R22		
18	Resistor	104-1104100K-J00	100K	0402	±5%	2	R30 R29		
19	Resistor	104-1104150K-J00	150K	0402	±5%	1	R23		
20	Capacitor	105-11042PXX-B10	2P/50V	0402	±5%	1	R61		
21	Capacitor	105-11049PXX-C10	9P/50V	0402	±0.25%	1	C42		
22	Capacitor	105-110447PX-J10	47P/50V	0402	±5%	1	C92		
23	Capacitor	105-1104100P-J10	100P/50V	0402	±5%	2	C86 C117		
24	Capacitor	105-1104220P-J10	220P/50V	0402	±5%	1	C87		
25	Capacitor	105-1104270P-J10	270P/50V	0402	±5%	2	C96 C48		
26	Capacitor	105-1104470P-J10	470P/50V	0402	±10%	6	C58 C56 C29 C27 C32 C3		
27	Capacitor	105-1104102P-K10	102P/50V	0402	±5%	14	C125 C14 C13 C68 C111 C130 C107 C8 C1 C9 C206 C243 C244 C245		
28	Capacitor	105-1104103P-K10	103P/50V	0402	±5%	16	C109 C95 C40 C34 C33 C47 C36 C37 C73 C69 C71 C126 C123 C35 C70 C38		
29	Capacitor	105-1104104P-K10	104P/16V	0402	±10%	5	C44 C90 C513 C514 C260		
30	Capacitor	105-1104105P-K10	105P/10V	0402	±10%	1	C91		
31	Resistor	104-11060RXX-J00	0R	0603	±5%	1	R12		
32	Resistor	104-11080RXX-J00	0R	0805	±5%	1	L28		
33	Resistor	104-110682RX-J00	82R	0603	±5%	2	R21 R20		
34	Resistor	104-1106100R-J00	100R	0603	±5%	2	R16 R17		
35	Capacitor	105-110615PX-J10	15P/50V	0603	±5%	2	L30 L32		
36	Capacitor	105-110639PX-J10	39P/50V	0603	±5%	1	C93		
37	Capacitor	105-110682PX-J10	82P/50V	0603	±5%	1	C45		
38	Capacitor	105-1106470P-J10	470P/50V	0603	±10%	5	C30 C66 C248 C31 C65		
39	Capacitor	105-1106102P-K10	102P/50V	0603	±5%	1	C41		
40	Capacitor	105-1106103P-K10	103P/50V	0603	±5%	1	TH1		
41	Capacitor	105-11083PXX-C10	3P/50V	0805	±5%	1	C15		
42	Capacitor	105-11083P5X-C10	3.5P/50V	0805	±0.1%	1	C53		
43	Capacitor	105-11085PXX-C10	5P/50V	0805	±0.1%	1	C103		
44	Capacitor	105-11086PXX-C10	6P/50V	0805	±0.1%	1	C64		
45	Capacitor	105-110812PX-J10	12P/50V	0805	±0.1%	1	C39		
46	Capacitor	105-110820PX-J10	20P/50V	0805	±0.25%	2	C59 C81		
47	Capacitor	105-110822PX-J10	22P/50V	0805	±5%	1	C67		
48	Capacitor	105-110827PX-J10	27P/50V	0805	±5%	1	C82		

49	Capacitor	105-1108100P-J10	100P/50V	0805	±10%	1	C72		
50	Capacitor	105-11081P5X-CF0	1.5P/250V	0805	±0.1%	3	C97 C105 C60	250V	
51	Capacitor	105-11082PXX-CF0	2P/250V	0805	±0.1%	1	C114	250V	
52	Capacitor	105-11083PXX-CF0	3P/250V	0805	±5%	3	C100 C7 C50	250V	
53	Capacitor	105-11084PXX-CF0	4P/250V	0805	±5%	1	C57	250V	
54	Capacitor	105-11085PXX-CF0	5P/250V	0805	±0.1%	1	C63	250V	
55	Capacitor	105-11086PXX-CF0	6P/250V	0805	±0.1%	1	C62	250V	
56	Capacitor	105-110810PX-JF0	10P/250V	0805	±0.1%	2	C98 C51	250V	
57	Capacitor	105-110812PX-JF0	12P/250V	0805	±0.1%	1	C83	250V	
58	Capacitor	105-110815PX-JF0	15P/250V	0805	±0.25%	3	C10 C23 C89	250V	
59	Capacitor	105-110820PX-JF0	20P/250V	0805	±0.25%	2	C88 C49	250V	
60	Capacitor	105-110822PX-JF0	22P/250V	0805	±5%	1	C94	250V	
61	Capacitor	105-1108102P-KD0	102P/500V 厚	0805	±5%	2	C79 C61	500V	
62	High Q capacitor	105-121320PX-J10	HQ 20P/500V	1210	±0.25%	1	C19	500V	
63	High Q capacitor	105-121368PX-J10	HQ 68P/500V	1210	±0.25%	2	C52 C54	500V	
64	High Q capacitor	105-1213102P-J10	HQ 102P/50V	1210	±5%	1	C78	50V	
65	SMT coil	108-10351002-000	0.35*1.0*2T		正绕	1	L7		
66	SMT coil	108-10351003-010	0.35*1.0*3T		正绕	1	L36		
67	SMT coil	108-10351503-010	0.35*1.5*3T		正绕	1	L12		
68	SMT coil	108-10351504-010	0.35*1.5*4T		正绕	1	L17		
69	SMT coil	108-10351505-010	0.35*1.5*5T		正绕	1	L15		
70	SMT coil	108-10351507-010	0.35*1.5*7T		正绕	1	L23		
71	SMT coil	108-10351508-010	0.35*1.5*8T		正绕	2	L16 L34		
72	SMT coil	108-10401504-010	0.4*1.5*4T		正绕	4	L14 L25 L22 L35		
73	SMT coil	108-10402004-010	0.4*2*4T		正绕	3	L9 L10 L33		
74	SMT coil	108-10402504-000	0.4*2.5*4T		正绕	1	L21		
75	SMT coil	108-10402505-000	0.4*2.5*5T		正绕	1	L27		
76	SMT coil	108-10602202-000	EL0.6*2.2*2TL		正绕	1	L11		
77	SMT coil	108-10602203-000	EL0.6*2.2*3TL		正绕	1	L3		
78	Inductor	107-11061N8X-S00	1.8NH	0603	±1%	1	R28		
79	Inductor	107-11066N8X-S00	6.8NH	0603	±1%	1	L24		
80	Inductor	107-110822NX-J00	22NH	0805	±1%	1	L26		
81	Inductor	107-110647NX-J00	47NH	0603	±1%	1	L6		
82	Inductor	107-110656NX-J00	56NH	0603	±1%	2	C28 L31		
83	Inductor	107-11081UXX-K00	1UH	0805	±1%	2	L29 L19		
84	TAIY	107-12081UXX-J00	1ROL	0805	±1%	3	L1 L4 L13		
85	TAIY	107-120833NX-G00	33NH线	0805	±1%	1	L18		
86	TAIY	107-1208220N-J00	220NH线	0805	±1%	1	L8		
87	Non-polarized ele	106-130810UX-K30	10UF/10V	0805	±20%	1	C242		
88	switch tube	101-1UMC4NTR-200	UMC4N			2	Q18 Q19		
89	Patch diode	102-11SS314U-060	KDS114E/UD	0603		3	D16 D15 D14		
90	Patch diode	102-1DP2S12C-220	JDP2S12CR	M6	1206	4	D9 D5 D10 D2		
91	SMT triode	103-1MA742XX-000	MA3J74200L	MA742		2	D13 D12		
92	SMT triode	103-12SK3078-220	2SK3078			2	Q3 Q1		
93	SMT triode	103-12SC4919-000	2SC4919			1	Q15		
94	SMT triode	103-12SK1830-180	2SK1830F			2	Q6 Q5		
95	SMT IC	101-175W01FU-140	TA75W01FU			1	U1		
96	SMT IC	101-1YZ3312X-000	YZ3312			1	A1		
97	Power tube	103-1S015NT1-000	AFT09MS015N	PLD-1.5W		2	Q4 Q2		
98	20-pin horizontal	122-11005020-000	20PIN(RF UP)		上接	1	J3		
99	SMT thermistor	104-130610KX-J00	T 10K	0603		1	C247		
100	Plug-in electroly	106-24K5100U-M60	100UF/25V	6*11		1	E3		
101	Plug-in resistanc	104-2125100R-J00	1W/100R			1	R171		
102	Magnetic bead ind	107-24D1C001-J00	3.5*4.7*0.8			2	L37 L46		
103	earjack	113-2ST22206-000	Φ3.5	3R不带铁圈		1	JACK2		
104	6188-Ea-jack	113-1T103C06-000	Φ2.5	ST-103C-06		1	JACK1		
105	Anr		SL16-KY-15			1	R24		

接收板 电子部份

序号 NO.	材料名称 Type Name	器件编号 Parts No.	规格描述			用量	位置	备注	应发
			Description				Standard	Remark	数量
1	RX板	100-DR200RXX-400	C7DR300UV-RX-51M-FD-4.0 2021.04.12			1		四层板	
2	Resistor	104-11040RXX-J00	0R	0402	±5%	34	R9 R3 R11 C70 C141 C123 R22 R13 C235 R34 R14 R12 R10 R1 C90 C142 C134 C124 R94 C22 C6 FB1 R15 R66 R67 R70 R91 R77 R75 C41 R46 R74 R71 R49		
3	Resistor	104-110418RX-J00	18R	0402	±5%	1	C18		
4	Resistor	104-110422RX-J00	22R	0402	±5%	1	R23		
5	Resistor	104-110447RX-J00	47R	0402	±5%	1	R33		
6	Resistor	104-1104180R-J00	180R	0402	±5%	1	R93		
7	Resistor	104-1104200R-J00	200R	0402	±5%	1	R27		
8	Resistor	104-1104300R-J00	300R	0402	±5%	2	C13 C40		
9	Resistor	104-1104330R-J00	330R	0402	±5%	3	R90 R89 R48		
10	Resistor	104-1104470R-J00	470R	0402	±5%	1	R21		
11	Resistor	104-11041KXX-J00	1K	0402	±5%	15	R222 R231 R232 R233 R303 R305 R26 R6 R38 R47 R50 R51 R80 R140 R141		
12	Resistor	104-11041K2X-J00	1.2K	0402	±5%	1	R69		
13	Resistor	104-11042K2X-J00	2.2K	0402	±5%	2	R45 R92		
14	Resistor	104-11042K7X-J00	2.7K	0402	±5%	2	C103 C104		
15	Resistor	104-11046K8X-J00	6.8K	0402	±5%	1	R68		
16	Resistor	104-110410KX-J00	10K	0402	±5%	6	R78 R5 R8 R87 C69 R180		
17	Resistor	104-110468KX-J00	68K	0402	±5%	2	R56 R57		
18	Resistor	104-1104100K-J00	100K	0402	±5%	5	R221 R53 R29 R97 R95		
19	Resistor	104-1104150K-J00	150K	0402	±5%	2	R98 R96		
20	Resistor	104-1104330K-J00	330K	0402	±5%	1	R55		
21	Capacitor	105-11041PXX-B10	1P/50V	0402	±0.1%	1	C154		
22	Capacitor	105-11041P5X-B10	1.5P/50V	0402	±0.1%	2	C219 C215		
23	Capacitor	105-11042PXX-B10	2P/50V	0402	±0.1%	3	C222 C117 C131		
24	Capacitor	105-11042P5X-B10	2.5P/50V	0402	±0.1%	1	C128		
25	Capacitor	105-11043PXX-B10	3P/50V	0402	±0.1%	4	C126 C221 C212 C177*手焊		
26	Capacitor	105-11044PXX-B10	4P/50V	0402	±0.1%	5	C144 C106 C114 C220 C73		
27	Capacitor	105-11045PXX-B10	5P/50V	0402	±0.1%	1	C151		
28	Capacitor	105-11046PXX-C10	6P/50V	0402	±0.1%	4	C120 C118 C223 C216		
29	Capacitor	105-11047PXX-C10	7P/50V	0402	±0.1%	3	C224 C85 C116		
30	Capacitor	105-11048PXX-C10	8P/50V	0402	±0.25%	1	R17		
31	Capacitor	105-110410PX-J10	10P/50V	0402	±0.25%	3	C133 C127 C122		
32	Capacitor	105-110412PX-J10	12P/50V	0402	±0.25%	2	C89 C188		
33	Capacitor	105-110415PX-J10	15P/50V	0402	±0.25%	4	C125 C268 C152 C163		
34	Capacitor	105-110418PX-J10	18P/50V	0402	±0.25%	2	C140 C100		
35	Capacitor	105-110422PX-J10	22P/50V	0402	±5%	3	C139 C280 C83		
36	Capacitor	105-110424PX-J10	24P/50V	0402	±5%	1	C358		
37	Capacitor	105-110427PX-J10	27P/50V	0402	±5%	1	C273		
38	Capacitor	105-110433PX-J10	33P/50V	0402	±5%	1	C270		
39	Capacitor	105-110439PX-J10	39P/50V	0402	±5%	2	C237 C99		
40	Capacitor	105-110447PX-J10	47P/50V	0402	±0.25%	2	C2 C167		
41	Capacitor	105-110468PX-J10	68P/50V	0402	±0.25%	1	C353		

42	Capacitor	105-1104100P-J10	100P/50V	0402	±0.25%	10	C218 C7 C372 C373 C374 C382 C176 C201 C204 C209		
43	Capacitor	105-1104120P-J10	120P/50V	0402	±10%	2	C241 C236		
44	Capacitor	105-1104470P-J10	470P/50V	0402	±10%	12	C121 C79 C80 C155 C158 C232 C231 C227 C226 C228 C233 C246		
45	Capacitor	105-1104102P-K10	102P/50V	0402	±5%	24	C181 C170 C95 C97 C283 C8 C49 C4 C65 C87 C81 C98 C88 C82 C78 C76 C74 C28 C388 C153 C175 C92 C96 C86		
46	Capacitor	105-1104103P-K10	103P/50V	0402	±5%	9	C129 C279 C130 C229 C225 C217 C214 C208 C157		
47	Capacitor	105-1104104P-K10	104P/16V	0402	±10%	16	C185 C169 C66 C281 C288 C289 C108 C9 C47 C5 C203 C29 R7 C183 C174 C39		
48	Capacitor	105-1104105P-K10	105P/10V	0402	±10%	13	C391 C111 C109 C3 C383 C205 C45 C365 C369 C376 C173 C171 C168		
49	Resistor	104-11060RXX-J00	0R	0603	±5%	2	FB3 L34		
50	Resistor	104-11080RXX-J00	0R	0805	±5%	1	L46		
51	Resistor	104-110847RX-J00	47R	0805	±5%	2	L27 L42		
52	Polarized electro	106-116A10UX-K20	10UF/16V	A	±20%	2	C313 C314		
53	Non-polarized ele	106-1308U1XX-K30	0.1UF/10V	0805	±5%	1	C112		
54	Non-polarized ele	106-13081UXX-K20	1UF/10V	0805	±20%	1	C110		
55	Non-polarized ele	106-130822UX-K30	22UF/10V	0805	±20%	1	C113		
56	Inductor	107-110610NX-J00	10NH	0603	±1%	1	L38		
57	Inductor	107-110612NX-J00	12NH	0603	±1%	1	L44		
58	Inductor	107-110627NX-J00	27NH	0603	±1%	1	L7		
59	Inductor	107-110647NX-J00	47NH	0603	±1%	1	L36		
60	Inductor	107-110668NX-J00	68NH	0603	±1%	2	L43 L39		
61	Inductor	107-1106100N-J00	100NH	0603	±1%	2	L77 L78		
62	Inductor	107-1106220N-J00	220NH	0603	±1%	2	L70 L76		
63	Inductor	107-1106270N-K00	270NH	0603	±1%	1	L11		
64	TAIY	107-120810NX-G00	10NH线	0805	±1%	1	L17		
65	TAIY	107-120822NX-G00	22NH线	0805	±1%	1	L35		
66	TAIY	107-120856NX-G00	56NH线	0805	±1%	5	L32 L16 L24 L20 L30		
67	TAIY	107-120882NX-G00	82NH线	0805	±1%	1	L28		
68	TAIY	107-1208220N-J00	220NH线	0805	±1%	1	L67		
69	TAIY	107-1208560N-J00	560NH线	0805	±1%	1	L40		
70	TAIY	107-1208820N-K00	820NH线	0805	±1%	1	L41		
71	线圈	108-10351503-010	0.35*1.5*3T			4	L23 L21 L19 L15		
72	Patch diode	102-11SS314U-060	KDS114E/UD	0603		4	D1 D2 D61 D71		
73	Patch diode	102-11N4148X-060	IN4148WT	SOD-523	0603	2	D4 D5		
74	Patch diode	102-1HVC131X-060	HVC131	0603		4	D17 D18 D19 D20		
75	Patch diode	102-1KDS160E-060	KDS160E-RTK/P	0603		1	D21		
76	SMT triode	103-1TA114EE-090	DTA114EE			1	Q22		
77	SMT triode	103-1C3356T1-000	2SC3356			1	Q5		
78	SMT triode	103-1SK318YB-250	3SK318 JP			2	Q2 Q14		
79	SMT triode	103-1SC4226T-120	2SC4226			3	Q43 Q3 Q4		
80	SMT IC	101-1DA5802N-000	RDA5802			1	U8		
81	SMT IC	101-1WX4818N-100	WX4818	FN-0.5-32		1	U5		
82	SMT IC	101-1FD6818X-000	FD6818	FN-0.5-32		1	U1		
83	SMT IC	101-1YZ3312X-000	YZ3312			1	A3		
84	SMT IC	101-104B332M-120	XC6204B332MR	SOT23-5		1	U6		

85	Crystal	110-126MXX00-060	26MHz DA	S03225		1	X1		
86	Crystal	110-132K7603-000	32.768K	S3215	FC-135	1	X5		
87	Crystal	110-351M5500-100	51.550M	±5	配对	1	XF2 XF1		
88	20-pin horizontal	122-12005020-000	20PIN (RF DOWN)		下接	1	J505		
89	40-pin horizontal	122-12005040-000	40PIN		下接	1	J912		
90	Feedline	130-113050XX-030	不带端L=50MM, 线径1.13MM			3			
91	RF wire	130-113067XX-030	L=67MM 线径: 1.13MM			1			

手咪板 电子部分

序号 NO.	材料名称 Type Name	器件编号 Parts No.	规格描述			用量	位置	备注 Remark	应发 数量
			Description				Standard		
1	Microphone PCBA	100-CKS10AXX-200	CKS-10A-2 2017.09.08			1			
2	Resistor	104-11040RXX-J00	0R	0402	±5%	4	R10 LD6 LD7 LD25		
3	Resistor	104-1104270R-J00	270R	0402	±5%	6	R28 R29 R30 R31 R32 R39		
4	Resistor	104-1104470R-J00	470R	0402	±5%	1	R43		
5	Resistor	104-1104820R-J00	820R	0402	±5%	4	R37 R38 R40 R42		
6	Resistor	104-11041KXX-J00	1K	0402	±5%	1	R36		
7	Resistor	104-11043K3X-J00	3.3K	0402	±5%	1	R19		
8	Resistor	104-110410KX-J00	10K	0402	±5%	3	R33 R34 R35		
9	Capacitor	105-1104220P-J10	220P	0402	±10%	1	C4		
10	Capacitor	105-1104470P-J10	470P	0402	±10%	1	C33		
11	Capacitor	105-1104102P-K10	102P	0402	±10%	1	C7		
12	Capacitor	105-1104104P-K10	104P	0402	±10%	2	C8 C31		
13	Resistor	104-11060RXX-J00	0R	0603	±5%	1	R20		
14	Capacitor	105-1106102P-K10	102P	0603	±10%	2	C3 C30		
15	Capacitor	105-1106103P-K10	103P	0603	±10%	2	C2 C24		
16	Capacitor	105-1106104P-K10	104P	0603	±10%	2	C1 C29		
17	Capacitor	105-1106105P-K20	105P	0603	±10%	1	C32		
18	Non-polarized ele	106-13081UXX-K20	1UF/10V	0805	±20%	1	C34		
19	Non-polarized ele	106-130822UX-K30	22UF/10V	0805	±20%	1	C23		
20	SMT triode	103-1TC114EE-190	DTC114EE			1	Q2		
21	SMT IC	101-104B502M-120	XC6204B502MR	SOT23-5		1	U3		
22	SMT IC	101-18S003F3-000	STM8S003F3	20脚		1	U1		
23	红灯	118-10206211-000	红灯	0603		1	LD3		
24	白灯	118-10106210-000	白灯	0603		6	LD4 LD5 LD10 LD21 LD23 LD24		
25	F24-with mini MIC	112-36050541-000	6*5-54±2DB		F24专用	1			

ADJUSTMENT/调整

Required Test Equipment

1. Stabilized Power supply

1. The supply voltage can be changed between 5V and 9V, and the current is 3A or more.
2. The standard voltage is 6.5V.

2. DC Ammeter

1. Class 1 ammeter (17 ranges and other features).
2. The full scale can be set to either 300mA or 3A.
3. A cable of less internal loss must be used.

3. Frequency Counter (f. counter)

1. Frequencies of up to 1GHz or so can be measured.
2. The sensitivity can be changed to 500MHz or below, and measurements are highly stable and accurate (0.2ppm or so).

4. Power Meter

1. Measurable frequency : Up to 500MHz
2. Impedance : 50Ω, unbalanced
3. Measuring range : Full scale of 10W or so
4. A standard cable (5D2W 1m) must be used.

5. RF Voltmeter(RF V.M)

1. Measurable frequency : Up to 500MHz or so.

6. Linear Detector

1. Measurable frequency : Up to 500MHz or so
2. Characteristics are flat, and CN is 60dB or more.

7. Digital Voltmeter

1. Voltage range : FS-18V or so
2. Input resistance : 1MΩ or more

8. Oscilloscope

1. Measuring range : DC to 30MHz
2. Provides highly accurate measurements for 5 to 25MHz.

9. AF Voltmeter (AF V.M)

1. Measurable frequency : 50Hz to 1MHz
2. Maximum sensitivity : 1mV or more

10. Spectrum Analyzer

1. Measuring range : DC to 1GHz or more

11. Standard Signal Generator (SSG)

1. Maximum frequency : 500MHz or more
2. Output : -133dBm/0.05μV to 7dBm/501mV
3. Output impedance : 50

12. Tracking Generator

1. Center frequency : 50kHz to 500MHz
2. Frequency deviation : ±35MHz
3. Output voltage : 100mV or more

13. Dummy Load

1. 8Ω, 3W or more

14. AF Generator(AG)

1. Frequency range : 100Hz to 100kHz
2. Output : 0.5mV to 1V

15. Distortion Meter

1. Measurable frequency : 30Hz to 100kHz
2. Input level : 50mV to 10Vrms

所需的测试设备

1. 稳定电源

1. 输出电源在5V和9V之间可调，并且电流为3A或更大。
2. 标准电压为6.5V。

2. 电流表

1. 高级电流表（17档和其它功能）
2. 满刻度可设定为300mA也可设定为3A。
3. 必须使用低消耗电缆。

3. 频率计数器（f. counter）

1. 可以测量到最大量程大约为1GHz的频率。
2. 灵敏度可调到500MHz或更低，测量为高稳定性和高准确度（大约为0.2ppm）。

4. 功率仪

1. 可测量的频率：最高到500MHz
2. 阻抗：50Ω，不稳定
3. 测量范围：满刻度大约为10W
4. 必须使用标准电缆（5D2W 1m）

5. 射频电压表(RF V. M)

1. 频率范围：最高大约到500MHz

6. 线性检测器

1. 频率范围：最高大约到500MHz
2. 特征函数是平展的，CN为60dB或更大

7. 数字电压表

1. 电压范围：大约FS-18V
2. 输入阻抗值：1MΩ或更大

8. 示波器

1. 测量范围：直流到30MHz
2. 5到25MHz间提供高准确度测量

9. 音频电压表(AF V. M)

1. 测量范围：50Hz到1MHz
2. 最高灵敏度：1mV或更高

10. 频谱分析仪

1. 测量范围：直流到1GHz

11. 标准信号发射器（SSG）

1. 测量范围：直流到1GHz
2. 输出：-133dBm/0.05μV to 7dBm/501mV
2. 输出阻抗：50Ω

12. 轨迹发生器

1. 中心频率：500MHz或更高
2. 频偏：±35MHz
3. 输出电压：100mV或更高

13. 假负载

1. 8Ω, 3W或更高

14. 音频发生器

1. 测量范围：100Hz到100kHz
2. 输出：0.5mV到1V

15. 失真测试仪

1. 测量范围：30Hz到100kHz
2. 输入电平：50mV到10Vrms

Squelch Level, S meter Level, Lo Power, QT Deviation, DQT Deviation, and battery warning.

Section common to the transmitter and receiver (VCO)

Item	Condition	Measurement		Adjustment		Specifications /Remarks
		Test equipment	Terminal	parts	Method	
Setting	Power supply voltage battery terminal: 6.5V					
VCO lock Voltage	CH: TX low	Digital voltmeter			0.8V	±0.1V
	CH: RX low				0.8V	±0.1V
	CH: TX high				4V	Less than 4.5V
	CH: RX high					

Receiver Section

Item	Condition	Measurement		Adjustment		Specifications /Remarks
		Test equipment	Terminal	parts	Method	
Band-pass filter	CH: RX center	Tra generator Spectrum analyzer		L6. L8. L9	Adjust to the spectrum waveform	3V
AF level	CH: RX center SSG output: -53dBm (50 μV) MOD:1KHz DEV :±3.0KHz	SSG Oscilloscope AF.V.M Distortion meter	ANT SP		Adjust to the MAX AF level Vo..knob position at 12 o'clock	
Sensitivity	CH: RX center CH: low CH: high SSG:output: -116dBm (0.35 μV) MOD:1KHz DEV :±3.0KHz				check	SINAD: 12dB or higher
Squelch Level	CH: RX center Level 9 SSG output: -116dBm (0.35 μV)				Adjust to open the squelch	
	Level 2 SSG output: -123dBm (0.16 μV)				Adjust to open the squelch	

Transmitter section

Item	Condition	Measurement		Adjustment		Specifications /Remarks	
		Test equipment	Terminal	parts	Method		
Transmit Frequency	CH: TX center PTT: ON	Frequency counter	ANT	RV1	Adjust to center frequency	Within±500Hz	
QT/DQT balance	CH: RX center	Modulation analyzer		R151	Recify the waveform to square wave		
Lo Power	CH: TX center CH: TX low CH: TX high	Power meter Current meter				Adjust it to 0.5W	Within±0.2W
HI Power	CH: RX center CH: TX low CH: TX high	Power meter Current meter				Adjust it to 2W	Within±0.2W
MAX DEV	CH: TX center AG:1KHz/50mV	Modulation Analyzer 15KHz LPF AG AF V.M				Adjust it to ±4.2KHz	±100Hz
						Check	±1.9KHz~2.2KHz
MIC Sensitivity	CH: TX center AG:1KHz/5mV					Check	±2.2KHz~3.8KHz
QT Deviation	CH: TX center CH: TX low CH: TX high QT:151.4Hz	Modulation Analyzer 3KHz LPF			Adjust it to 0.50KHz	±0.05Hz	
				CH:TX center			
DQT Deviation	CH: TX center CH: TX low CH: TX high DQT:023N	Modulation Analyzer 15KHz LPF			Adjust it to 0.75KHz	±0.05Hz	
				CH:TX center			
VOX Level					Adjust it to [4]		
Battery Warning	Battery terminal: 3.6V						

静噪级别, S计电平, 低功率, QT偏差, DQT偏差和电池警告
发射部和接收部共用部分(压控振荡器)

项目	条件	测量		调整		规格备注
		测试设备	终端	部件	方法	
设定	电源电压电池终端: 7.4V					
压控振荡器	CH: 发射低端频点	数字电压表			1V	±0.1V
	CH: 接收低端频点				1V	±0.1V
	CH: 发射高端频点				4V	少于 4.0V
	CH: 接收低端频点					

接收部分

项目	条件	测量		调整		规格备注
		测试设备	终端	部件	方法	
带通滤波器	CH: 接收中心频点	Tra发生器 频谱分析仪		L6. L9. L8	调整频谱波形	3V
音频电平	CH: 接收中心频点 SSG输出: -53dBm (50 μV) MOD:1KHz DEV :±3.0KHz	标准信号发射器 示波器 音频电压表 失真测试仪	天线 扬声器		调整到最大音频电平 Vo旋钮的位置在12点钟	
灵敏度	CH: 接收中心频点 CH:低 CH: 高 SSG输出: -116dBm (0.35 μV) MOD:1KHz DEV :±3.0KHz				检查	SINAD: 12dB 或者 更高
静噪抑制电路 电平	CH: 接收中心频点					
	第9级 SSG 输出: -116dBm (0.35 μV)				经调整打开静噪	
	第2级 SSG 输出: -123dBm (0.16 μV)				经调整打开静噪	

发射部

项目	条件	测量		调整		规格备注	
		测试设备	终端	部件	方法		
发射频率	CH: 接收中心频点 PTT: 开启	频率计数器	天线	RV1	调整到中心	±500Hz以内	
QT/DQT 平衡	CH:接收中心频点	频谱分析仪		R151	将波形整流为方形图		
低功率	CH:发射中心频点 CH: TX low CH: TX high	功率表 电流表				调整到 0.5W	±0.2W以内
高功率	CH: 接收中心频点 CH: TX low CH: TX high	功率表 电流表				调整到 2W	±0.2W以内
最大偏差	CH: 发射中心频点 AG:1KHz/50mV	Modulation Analyzer 15KHz LPF AG AF V.M				调整到±4.2KHz	±100Hz
						检查	±1.9KHz~2.2KHz
MIC灵敏度	CH: 发射中心频点 AG:1KHz/5mV					检查	±2.2KHz~3.8KHz
QT偏差	CH:发射中心频点 CH: 发射低端频点 CH: 发射高端频点 QT:151.4Hz	频谱分析仪 3KHz LPF			调整到 0.50KHz	±0.05Hz	
					CH:发射中心频点		
DQT偏差	CH: 发射中心频点 CH: 发射低端频点 CH: 发射高端频点 DQT:023N	频谱分析仪 15KHz LPF			调整到 0.75KHz	±0.05Hz	
					CH:发射中心频点		
声控级别					调整到 [4]		
电池电平	电池终端: 3.6V						

ADJUSTMENT FREQUENCY LIST

Description	C	
CH	TX f(MHz)	R X f(MHz)
Center	155.025MHz	155.500MHz
Low	136.025MHz	136.025MHz
Hi	173.975MHz	173.975MHz

调整频率清单

描述	C	
信道	发射频率 (MHz)	接收频率 (MHz)
中心	155.025MHz	155.025MHz
底	136.025MHz	136.025MHz
高	173.975MHz	173.975MHz

ADJUSTMENT FREQUENCY LIST

Description	C	
CH	TX f(MHz)	R X f(MHz)
Center	440.025MHz	440.025MHz
Low	400.025MHz	400.025MHz
Hi	479.975MHz	479.975MHz

调整频率清单

描述	C	
信道	发射频率 (MHz)	接收频率 (MHz)
中心	440.025MHz	440.025MHz
底	400.025MHz	400.025MHz
高	479.975MHz	479.975MHz

BPF-wave/波段

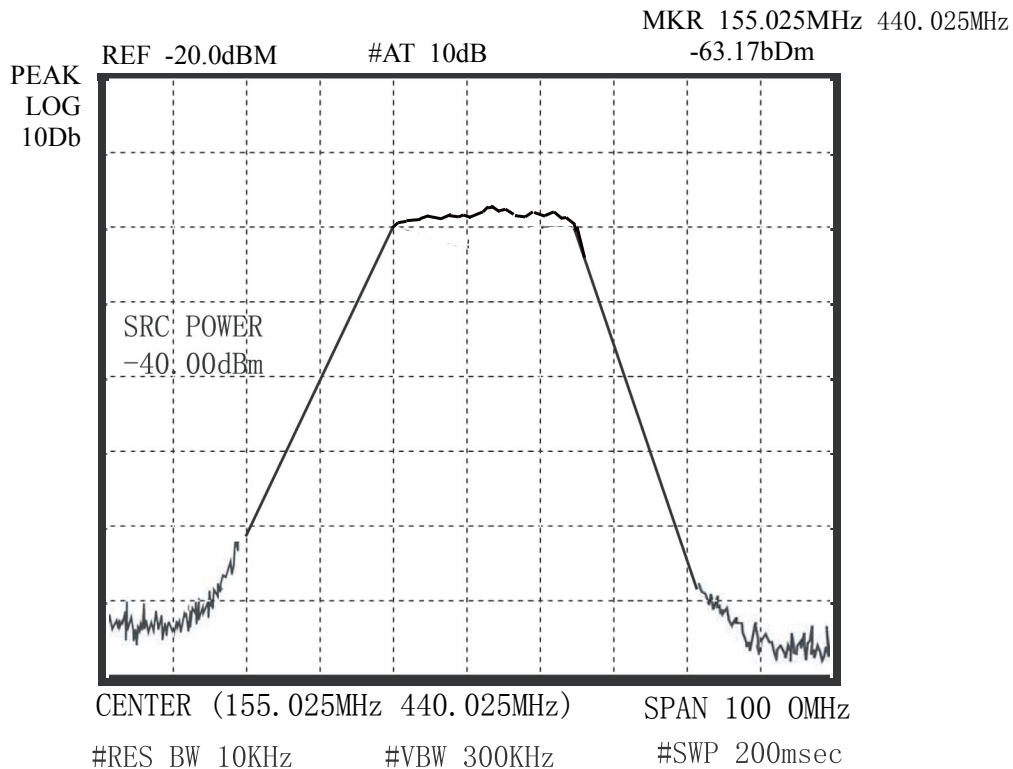

Notes:

- Adjust the TX VCO trimmer within a short period of time (Appros. 10 seconds). When the transceiver is in TX mode and the final amplifier transistor is detached from the chassis for a long time, it may cause thermal damage to the transistor (No heatsink).

注释:

在短时间内调整发射压控微调电容器(大约10秒). 当收发机处于发射模式, 并且末级放大器晶体管长时间从机架拔出, 则可能会对晶体管产生热损伤(无散热器).

BLOCK DIAGRAM

此颜色的方框是TX板
 此颜色的方框是RX板

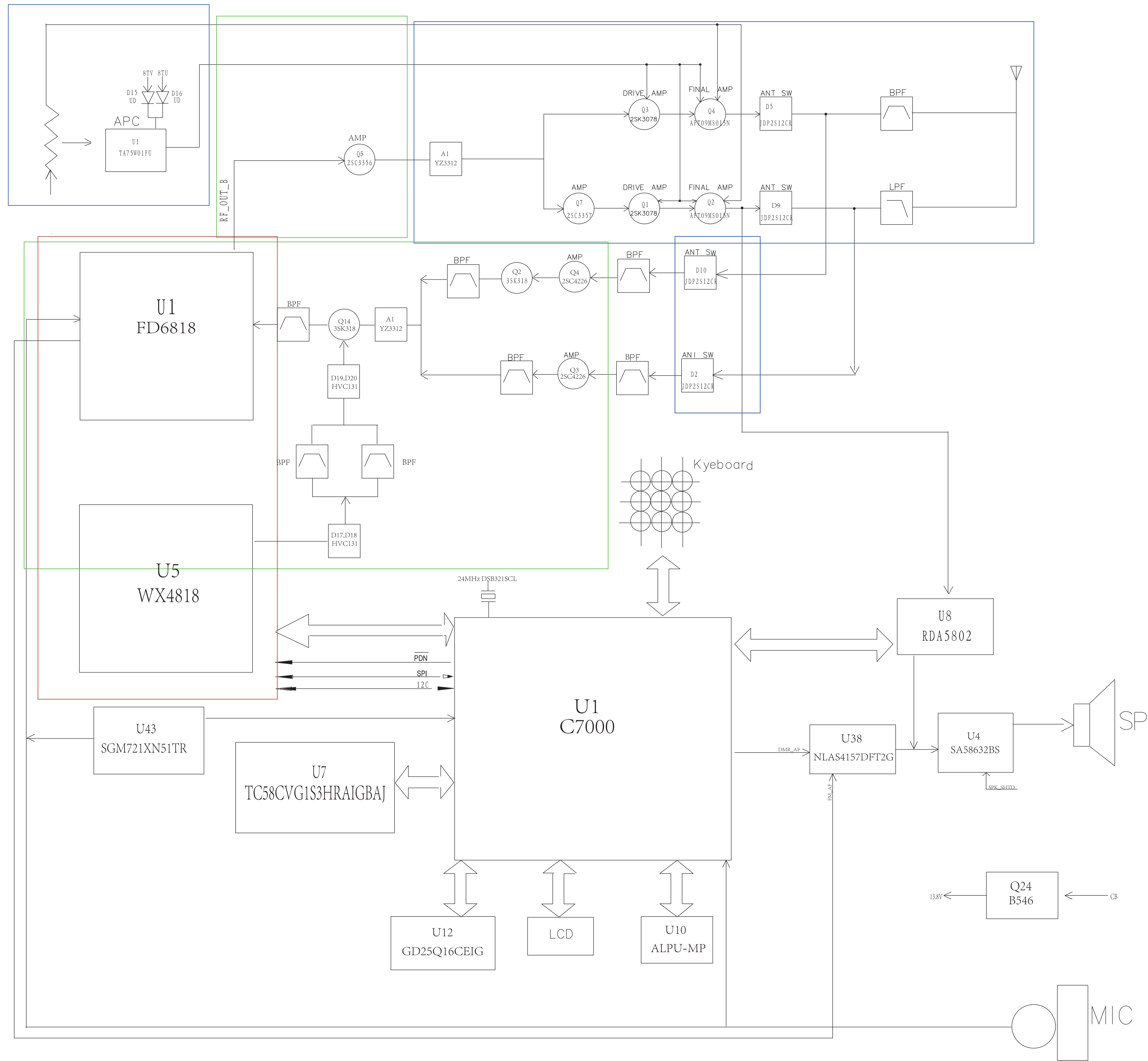

MCU板

C7000部分电路

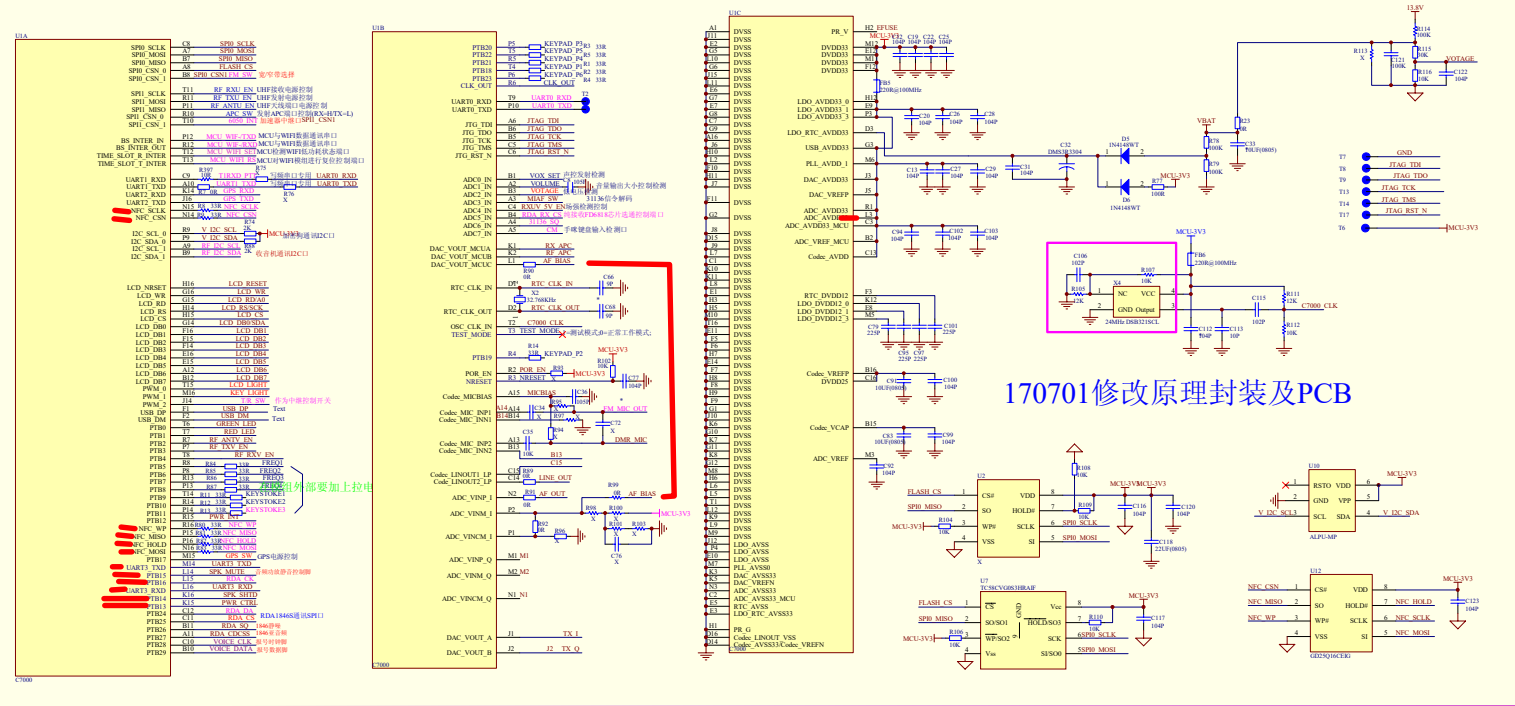

170701修改原理封装及PCB

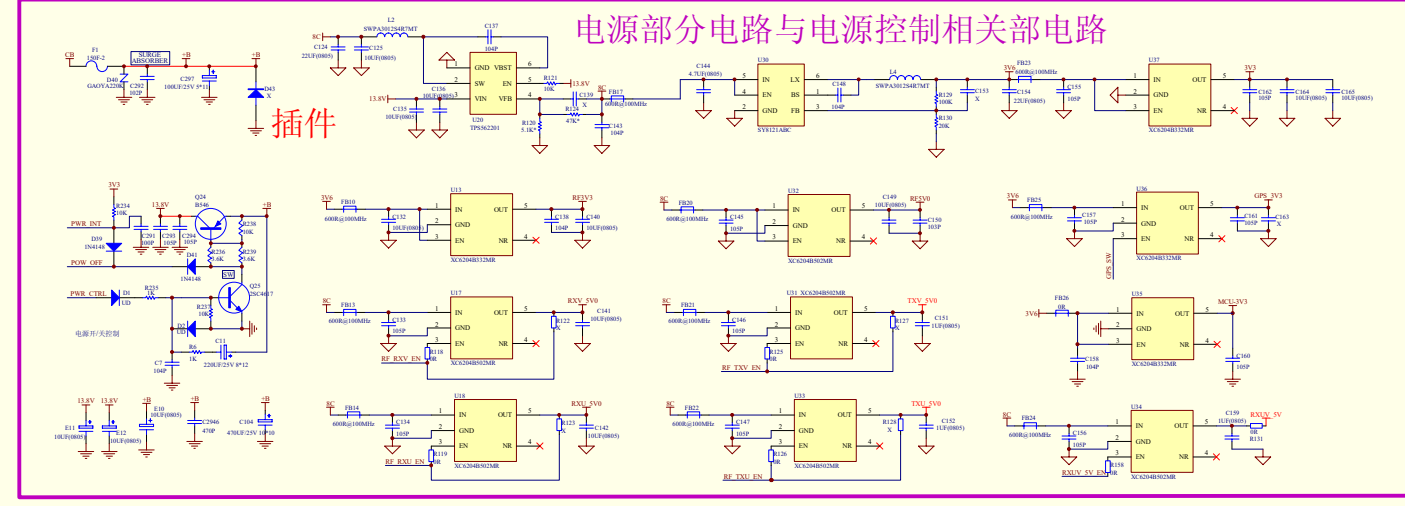

插件

电源部分电路与电源控制相关部电路

GPS部分电路(选配)

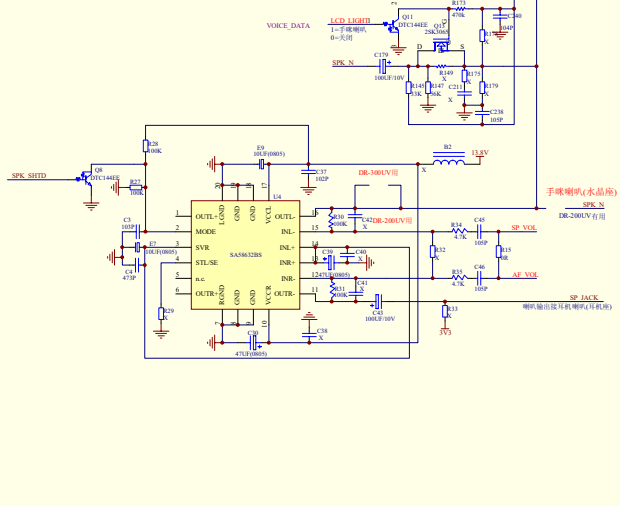

MIC语音与模拟/数字模式控制电路

声控电路

RXD写频电路

常规K头耳机座

Symbol	Number	Revision
A	1	1.0
B	1	1.0
C	1	1.0
D	1	1.0
E	1	1.0
F	1	1.0
G	1	1.0
H	1	1.0
I	1	1.0
J	1	1.0
K	1	1.0
L	1	1.0
M	1	1.0
N	1	1.0
O	1	1.0
P	1	1.0
Q	1	1.0
R	1	1.0
S	1	1.0
T	1	1.0
U	1	1.0
V	1	1.0
W	1	1.0
X	1	1.0
Y	1	1.0
Z	1	1.0

UHF/VHF双段接收部分原理图

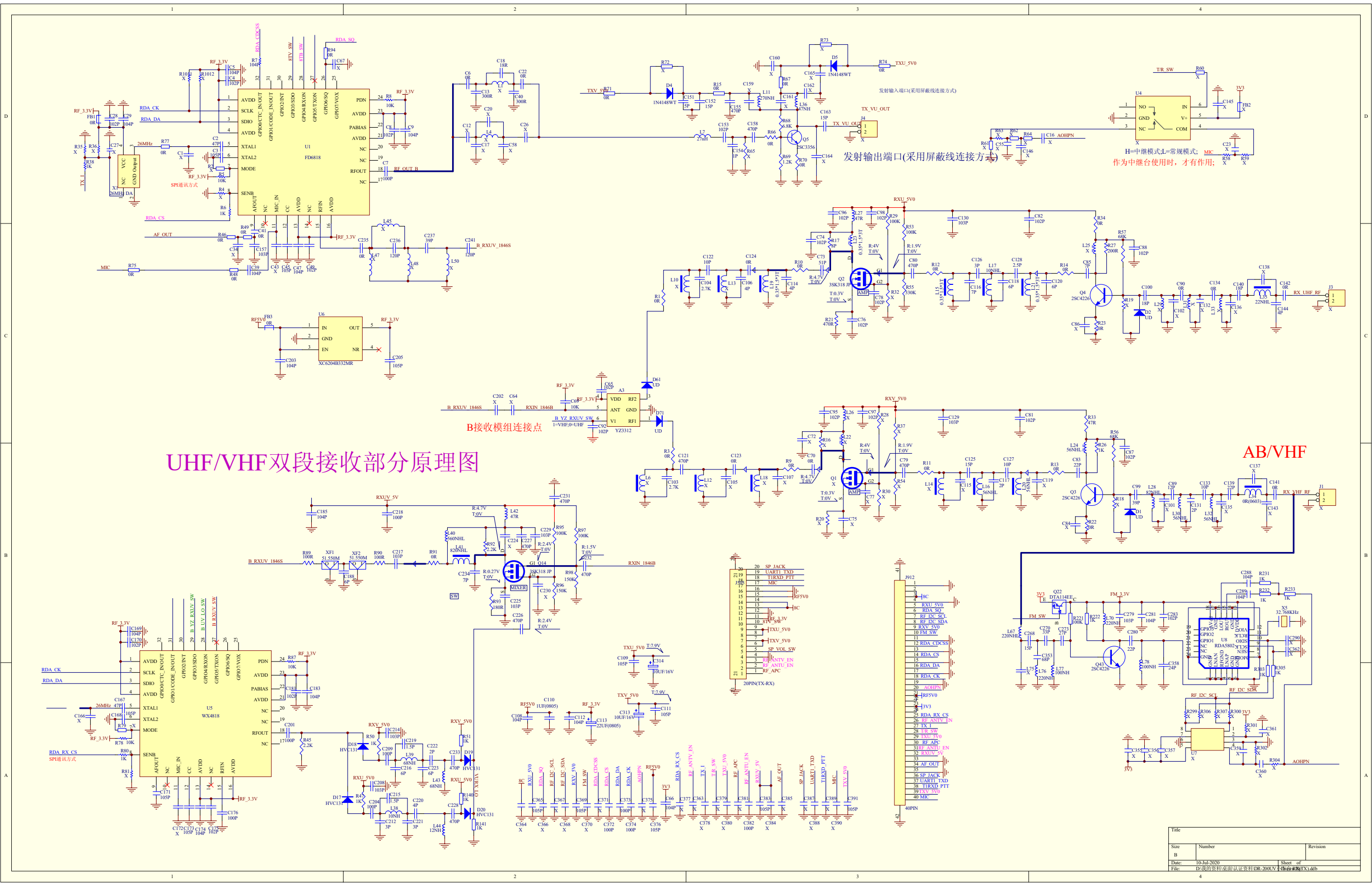

B接收模组连接点

AB/VHF

Title	Number	Revision
B	10-Jul-2020	Sheet of
D:\我的资料桌面\认证资料\DR-200UV\DR-200UV.dwg		

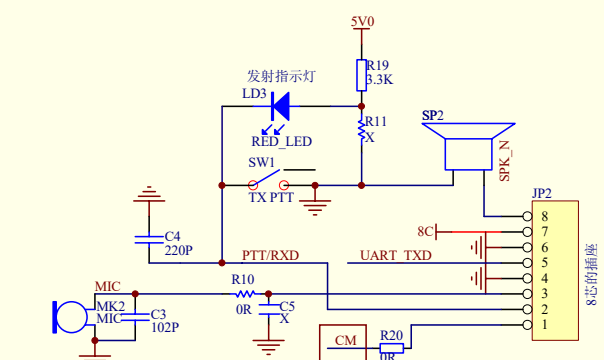
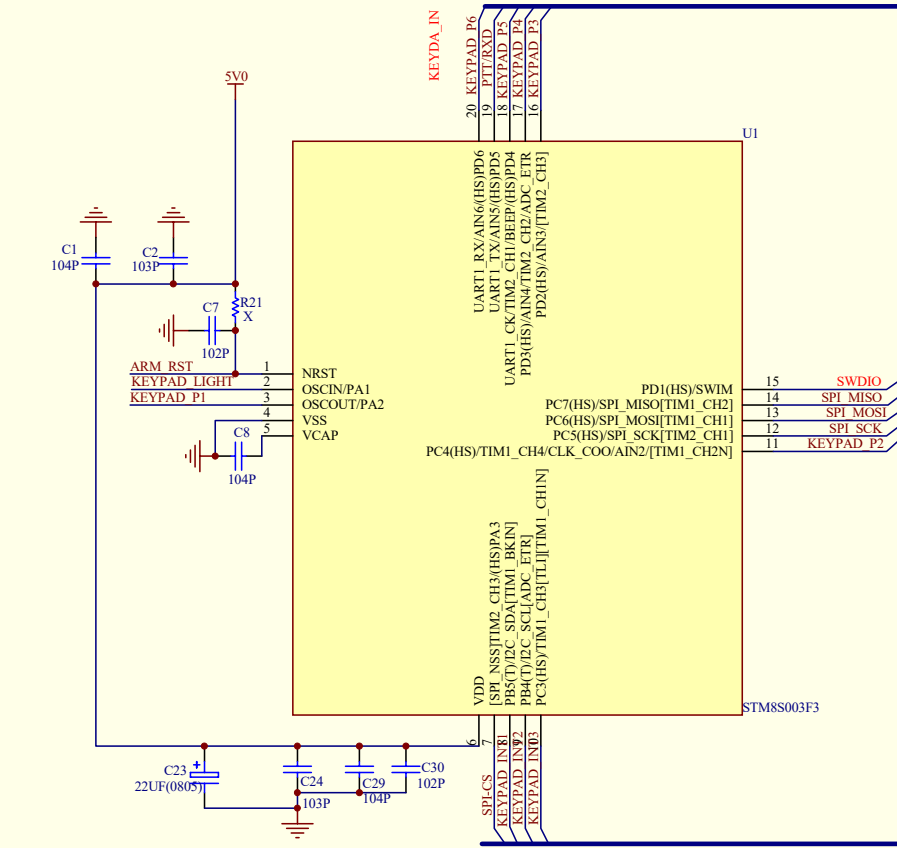

话筒用插脚

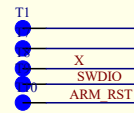

JTAG测试点, 布板时按顺序排列

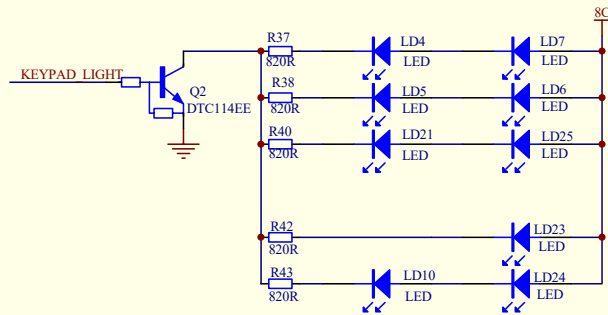
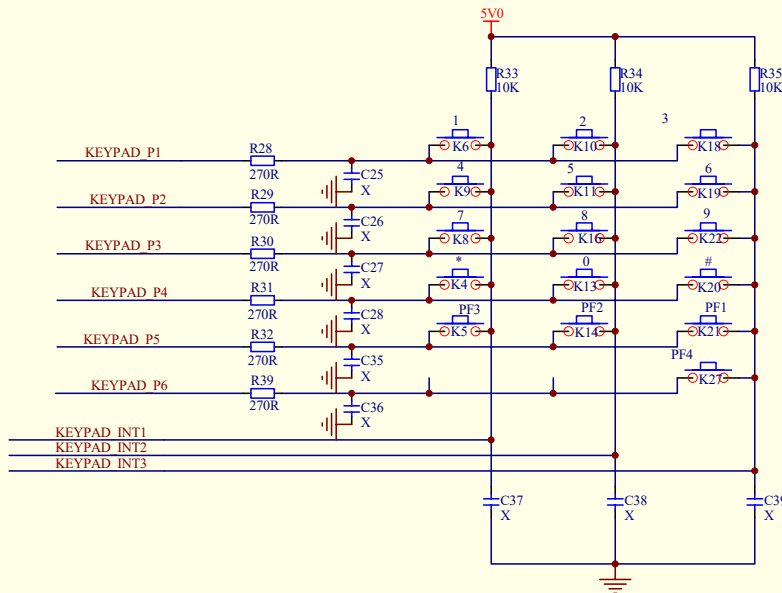
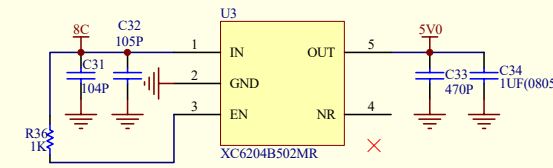
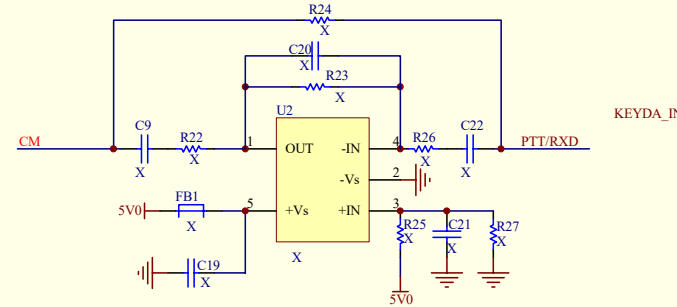

Title		
Size	Number	Revision
B		
Date:	10-Jul-2020	Sheet of
File:	D:\我的资料桌面\认证资料\CKS-10A-2	Drawn By:

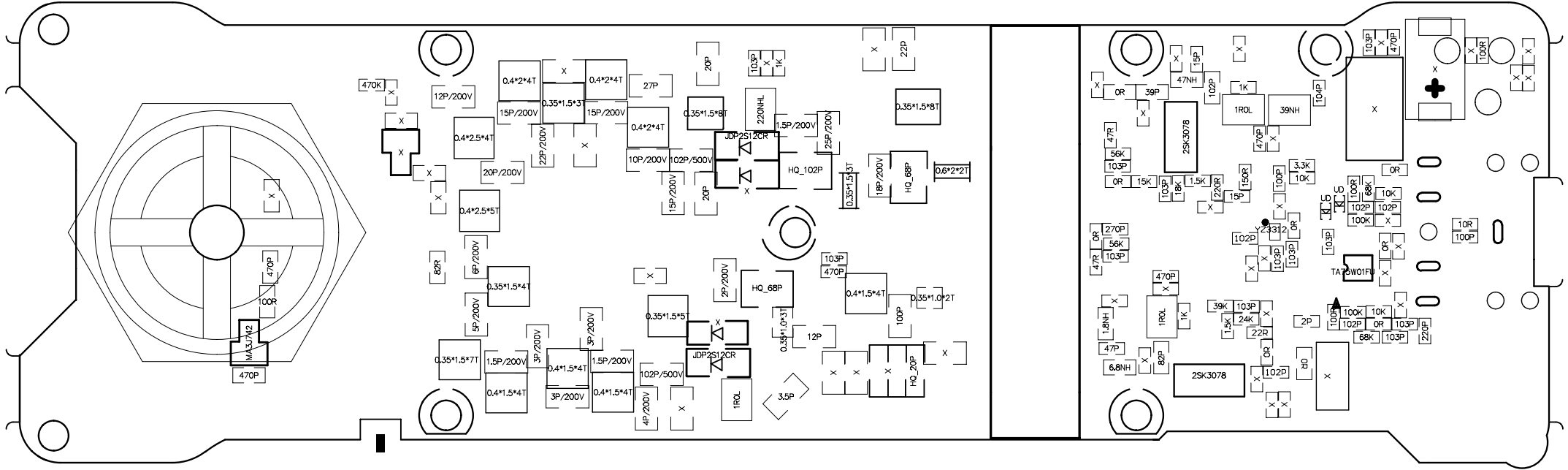

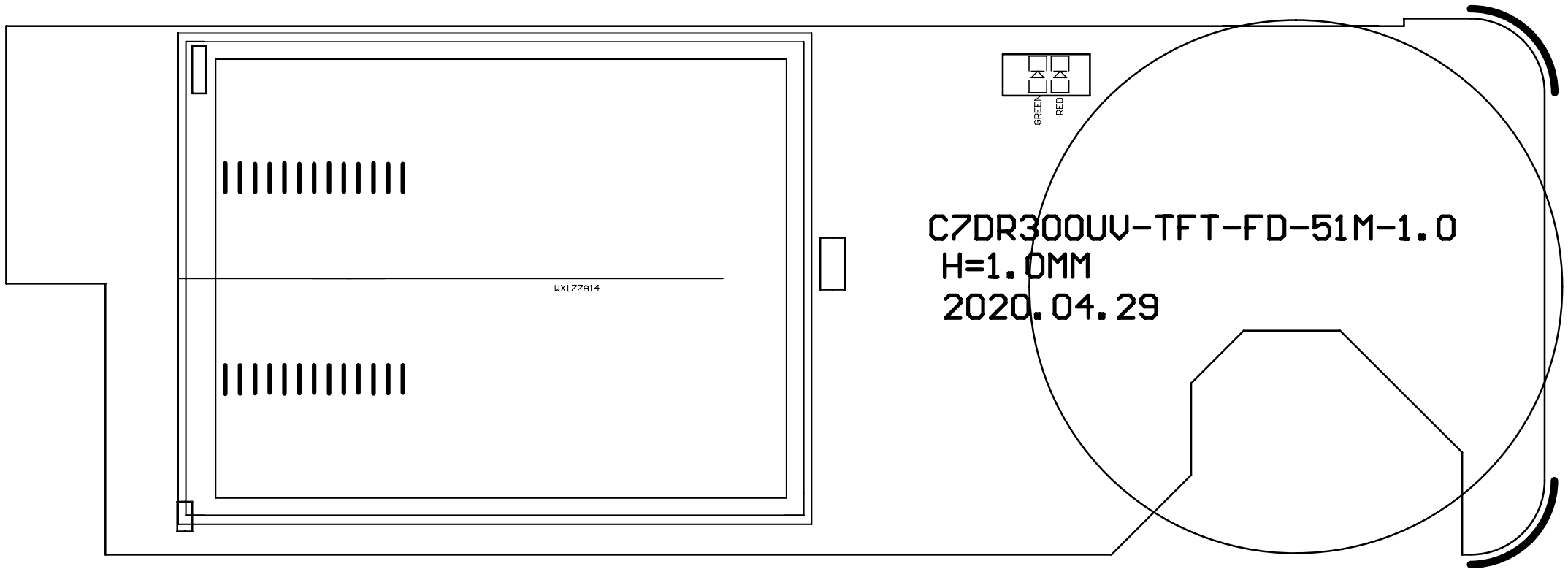

|||||

WX177A14

|||||

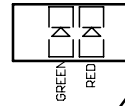

C7DR300UV-TFT-FD-51M-1.0
H=1.0MM
2020.04.29

TX PTT

SP

220P X
3.3K

CKS-10A-2
2017.09.08

H=1.0MM 10K X

X 10K

270R X

820R

X X
X X
X X

820R



270R X

X X
X X
X X
X X
X X

STM8S008F3 10K X

270R X

820R

DTIC114EE

OR

102P X 104P 103P
103P 102P

X 270R

22UF(0805)

820R

X 270R

820R

104P 104P

270R X

470P

1UF(0805)

104P 105P

XC6204B502MR



1K

OR 102P X

8

3

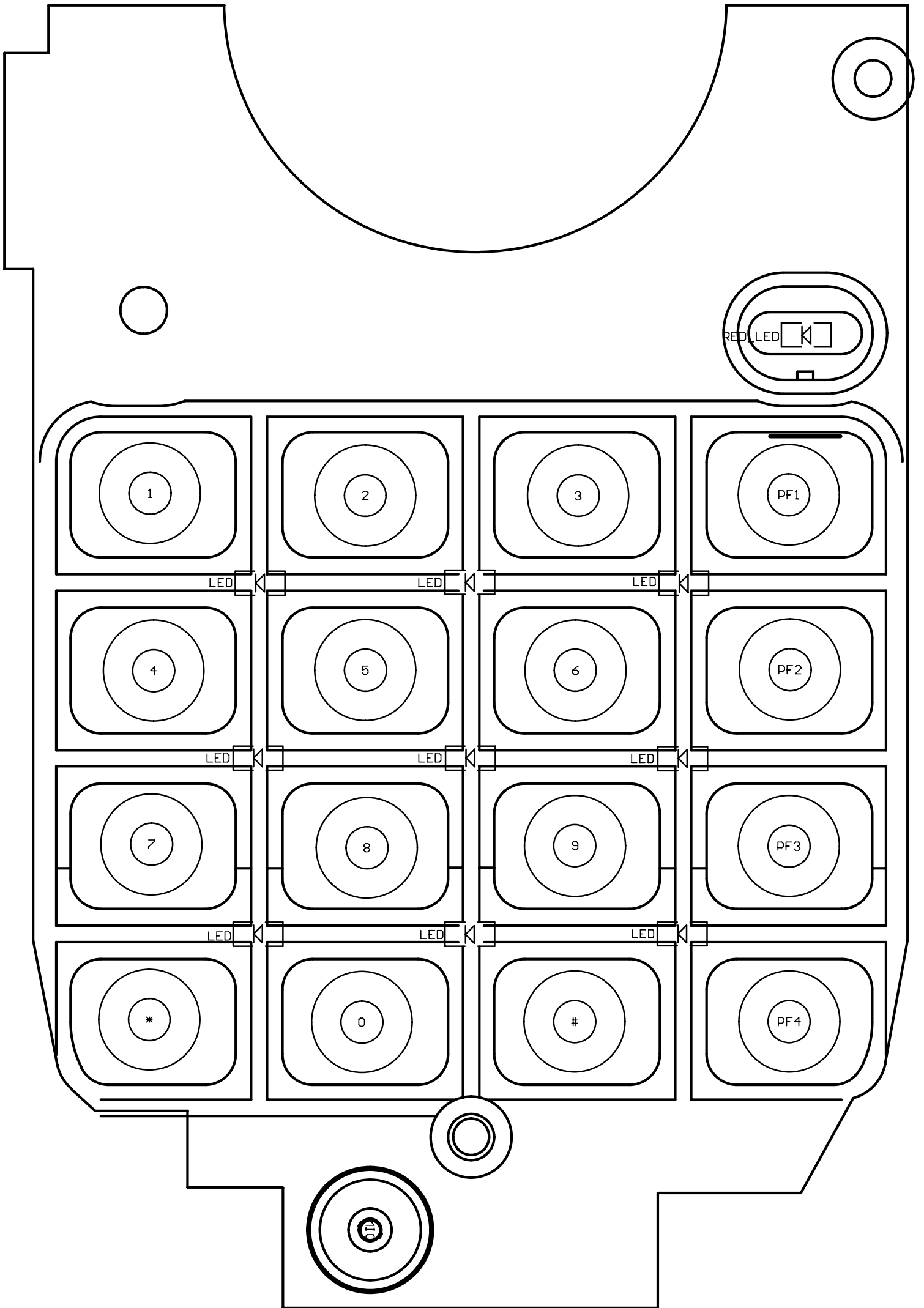

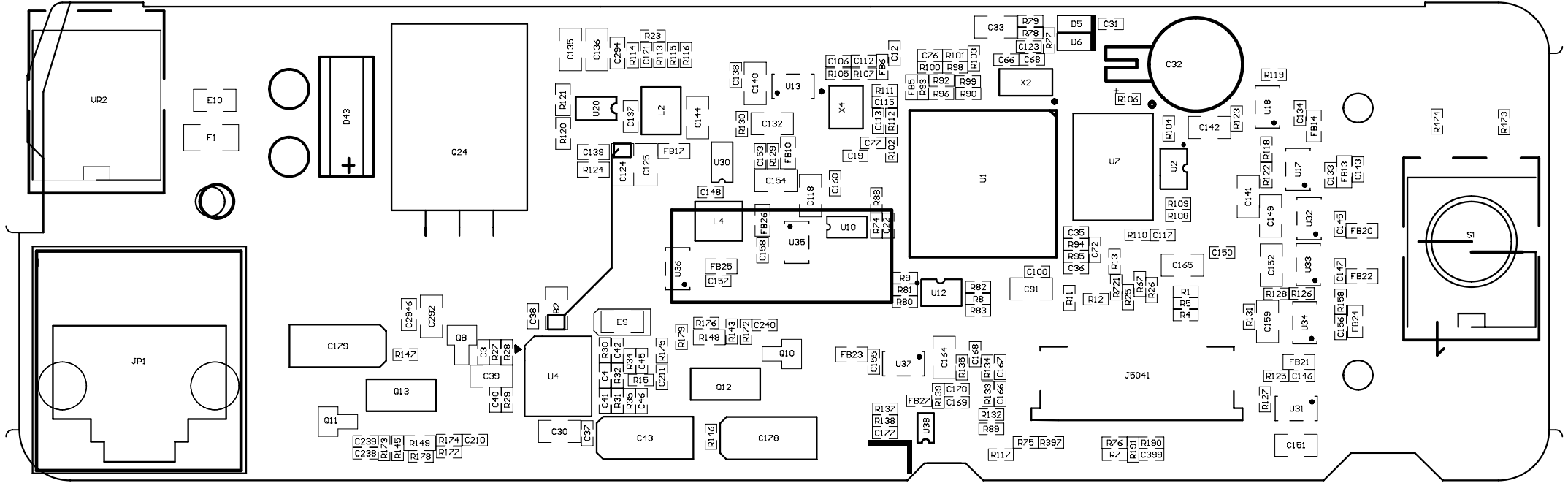

C7DR200_300MCU-FD-51M-2.0
H=1.2MM

2020.04.29

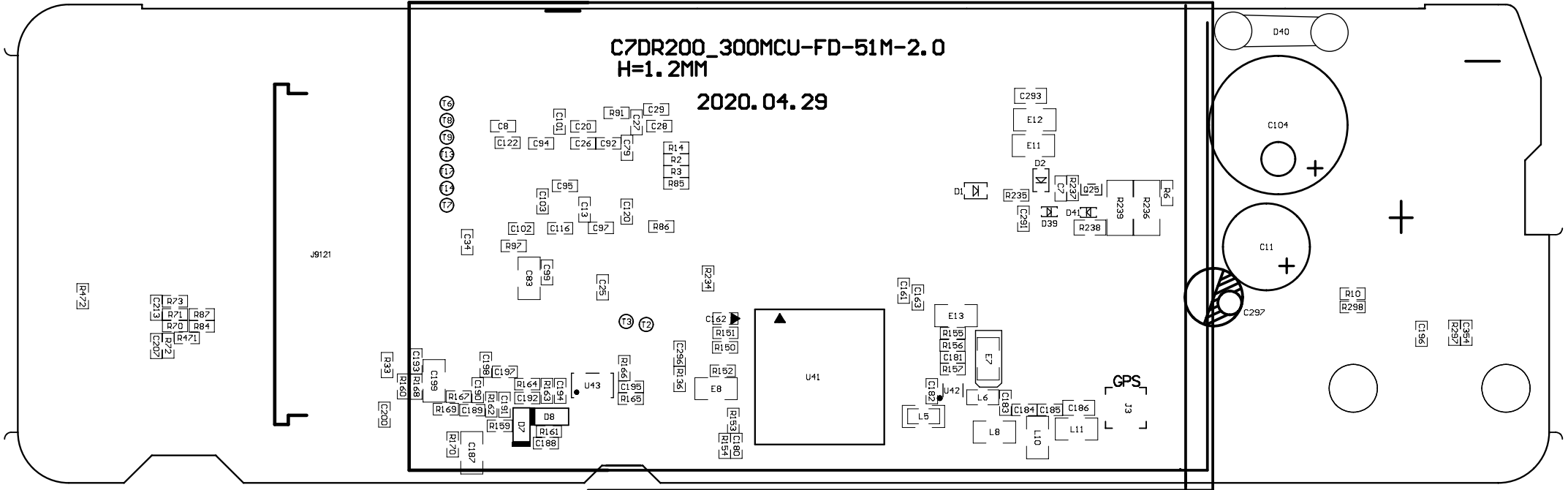

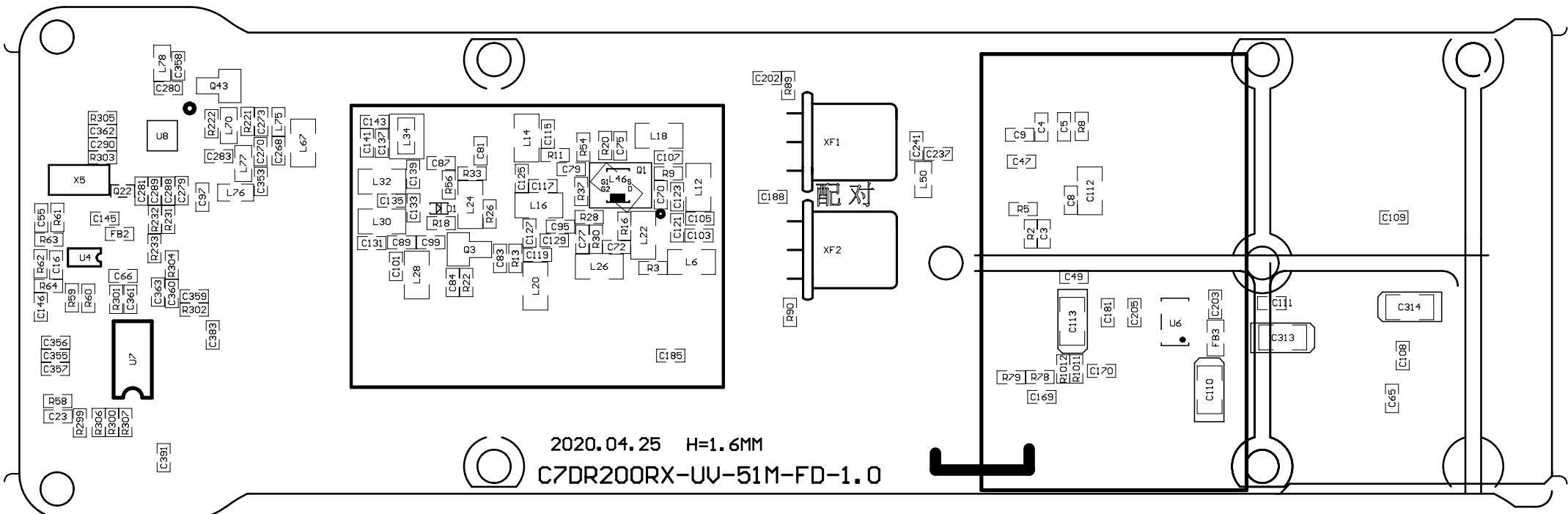

2020.04.25 H=1.6MM
C7DR200RX-UU-51M-FD-1.0

D6-2

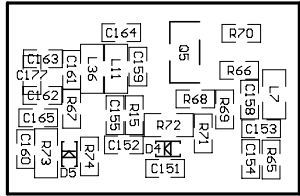

J505

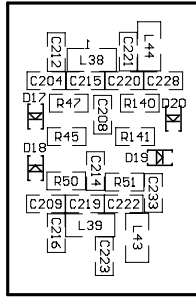
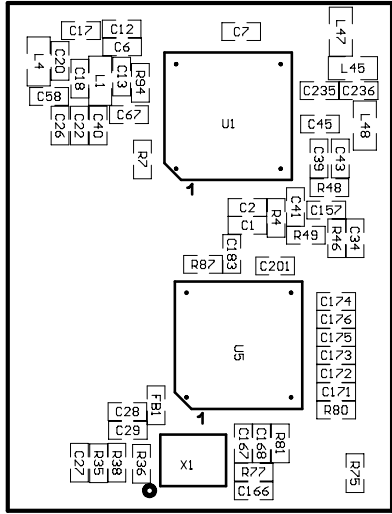

F24

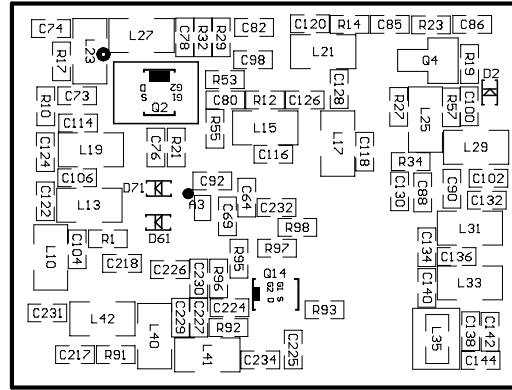

J912



- C364
- C365
- C366
- C367
- C368
- C369
- C370
- C371
- C372
- C373
- C374
- C375
- C376
- C377
- C378
- C379
- C380
- C381
- C382
- C384
- C385
- C387
- C388
- C389
- C390

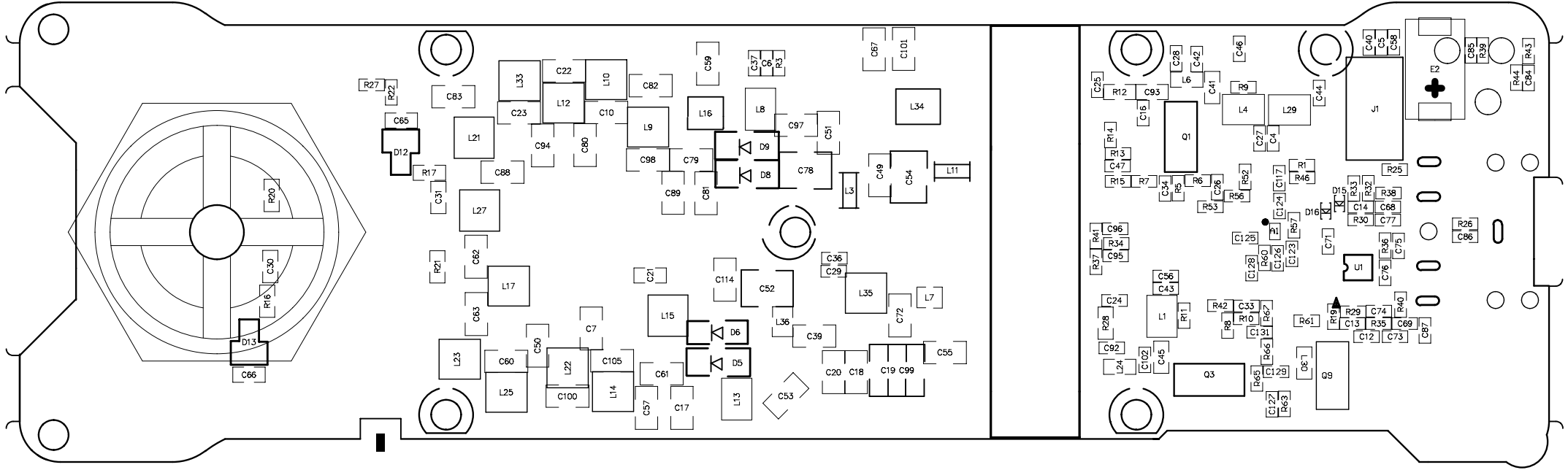

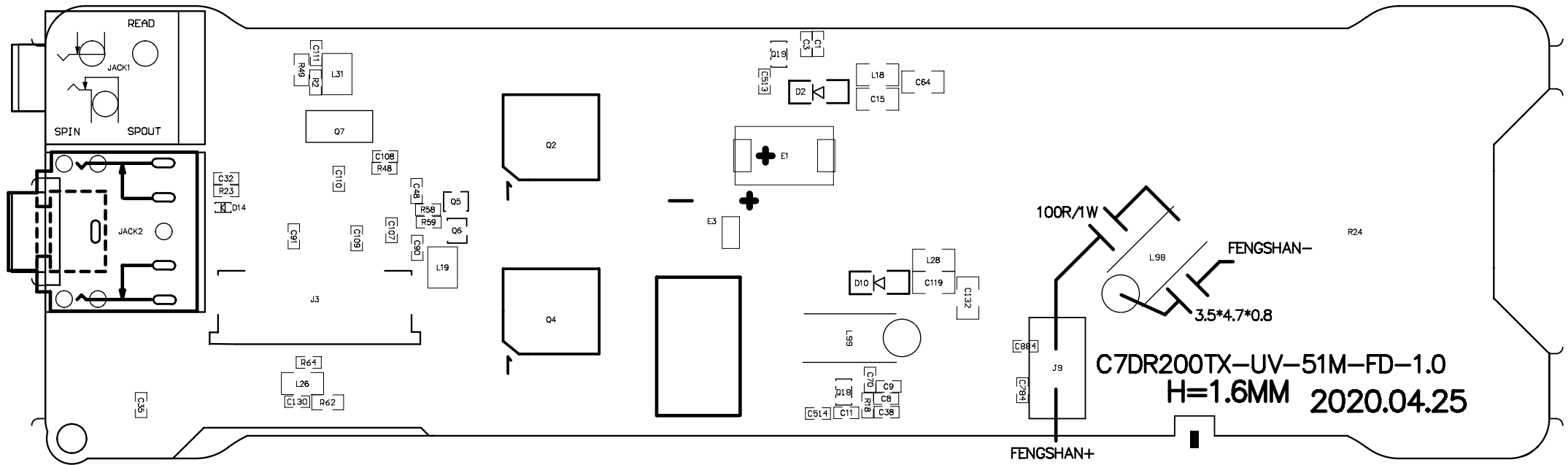

100R/1W

FENGSHAN-

3.5*4.7*0.8

C7DR200TX-UV-51M-FD-1.0

H=1.6MM 2020.04.25

FENGSHAN+

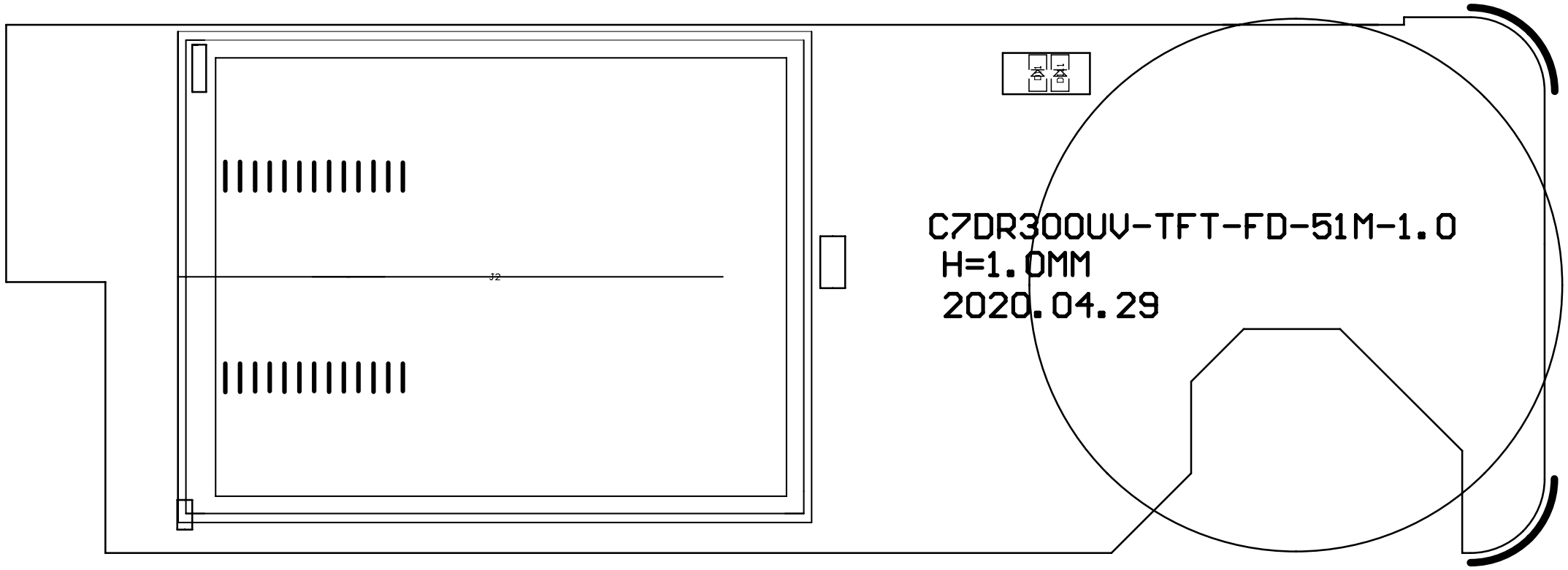

各各

C7DR300UV-TFT-FD-51M-1.0
H=1.0MM
2020.04.29

32

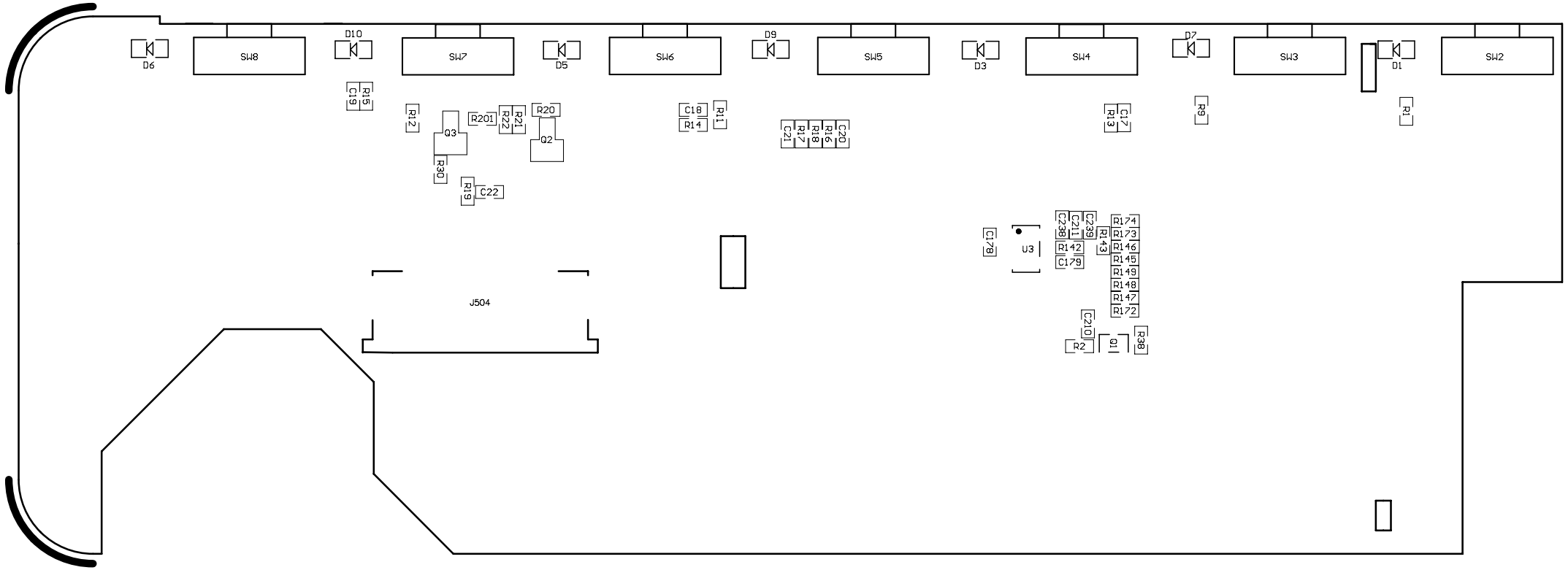

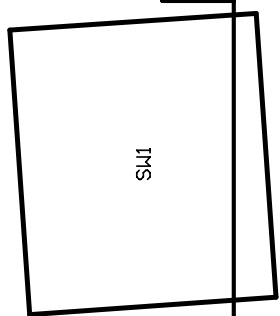

SP2

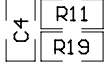

CKS-10A-2
2017.09.08
H=1.0MM

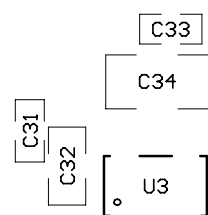
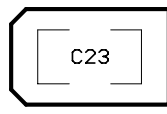
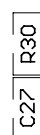
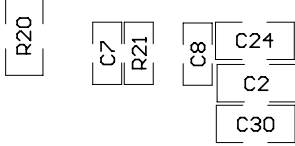
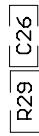
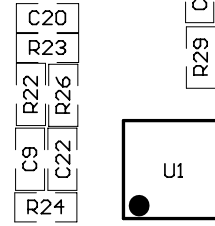
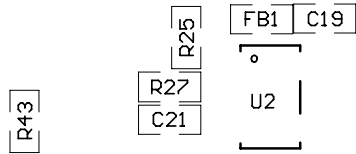
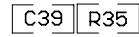

8

3

