

## Table of Contents

- [Specifications](#)
- [Controls and Connections](#)
- [Basic Programming Procedures](#)
- [Technical Analysis of the circuits](#)
- [Transistors Voltage Chart](#)
- [RCI SECRETS](#)
- [REPAIR TRICKS](#)

## DIAGRAMS

- [Main PCB Schematic Diagram](#)
- [CPU PCB Schematic Diagram](#)
- [Chassis Exploded View Drawing](#)
- [Inter-connection Diagram](#)

## PCB Layouts and Parts

- (EPT295013Z)
- [Main PCB Parts Layout Top View](#)
- [Main PCB Copper Side View](#)
- [LCD PCB](#) (EPT295021Z)
- [CPU PCB](#) (EPT295043Z)
- [MIC UP/ DW](#) (EPT295080Z)
- [MIC Jack PCB](#) (EPT295070Z)
- [SWR PCB](#) (EPT360040Z)
- [VR \(A\) PCB RF/ MIC VOL/ SQ](#) (EPT295050Z)
- [VR \(B\) PCB RF/ CAL](#) (EPT295060Z)
- [CH / Switch PCB](#) (EPT295090A)
- [MODE PCB](#) (EPT295090Z)
- [Push Button Switch PCB](#) (EPT295031Z)

## PARTS LISTS

- [Capacitors](#)
- [Coils, Transformers, Crystals, Filters](#)
- [Resistors](#)
- [IC's, Transistors](#)
- [Diodes](#)
- [Wire, Jumpers, Connectors](#)
- [Chassis, Miscellaneous & Mechanical Parts](#)

## RADIO MODIFICATIONS

- [MODIFY FOR 26 Mhz -32 Mhz](#)
- [MODIFY FOR 25 Mhz -33 Mhz](#)
- [Ham to CB Mode Modification](#)
- [INCREASE YOUR POWER !!](#)
- [HEAVY SWINGER Mod \(Modulation\)](#)
- [TUNE UP/ MOD](#)
- [Upgrading AM detection](#)
- [INCREASE AUDIO](#)
- [Add an Automatic SQUELCH](#)
- [BATTERY PROBLEMS](#)
- [CLARIFIER MOD](#)
- [CAR'S LIGHTER Install](#)
- [LCD & LEDS](#)
- [MIKE Wiring](#)
- [Protect From Polarity Inversions](#)
- [MOD FOR FASTER SCAN SPEED](#)
- [EXTERNAL S-METER](#)
- [TALK BACK MODIFICATION](#)
- [TONE MODIFICATION](#)

## ALIGNMENT PROCEDURES

- [TX Alignment](#)
- [TX Alignment Locations](#)
- [RX Alignment](#)
- [RX Alignment Locations](#)
- [PLL Alignment](#)
- [PLL Alignment Locations](#)

## RCI-2950 Specifications

### Key Features

- Full Band Coverage** - Covers the 10 Meter Amateur Band from 28.0000 to 29.6999 MHz.
- All Mode Operation** - Operates on USB, LSB, CW, AM and FM.
- Brightness Control** - Four Step LCD brightness control for easy viewing under any condition.
- Repeater Offset Switch** - Gives you standard offsets for repeater operation.
- Programmable Frequencies** - Allows you to program up to 10 individual frequencies. Includes battery backup.
- Built in Dual VFO** - Choose steps of 10kHz, 1kHz or 100Hz, manual or scan
- RIT** - Receiver Incremental Tuning to fine tune the receive frequency up to +/- 3kHz.
- Squelch** - Cuts off or eliminates receiver background noise in the absence of incoming signals.
- Noise Blanker** - Greatly reduces repetitive impulse noise.
- RF Gain Control** - Reduces the gain of the receiver under strong signal conditions to prevent overloading.
- RF Power Output Selector** - Lets you select transmitting output power
- External Speaker Connection** - Place a speaker anywhere for convenient listening.
- PA Mode** - Use an external speaker for a mobile PA system.
- LCD Display** - Large, easy to read backlit LCD display.
- Multi-Function LCD Meter** - Indicates transmit power, receive signal strength, modulation, SWR Calibration and SWR.

### Specifications

#### *General*

- Frequency Range: 28.0000~29.6999 MHz
- Tuning Steps: 100Hz, 1kHz, 10kHz, 100kHz, 1MHz
- Emission Types: USB, LSB(A3J), CW(A1), AM(A3), FM(F3)
- Frequency Control: Phase-Locked Loop Synthesizer
- Frequency Tolerance: 0.005%
- Frequency Stability: 0.001%
- Operating Temperature Range: 0 to 40 degrees C.
- Antenna Impedance: 50 Ohms
- Microphone: 400 Ohms, Dynamic PTT
- Speaker: 8 Ohms, 2 Watts
- Display: Digital Frequency, LCD
- Meter Function: RF Output, Receive Signal Strength, Modulation, SWR Calibration, SWR
- Power Requirements: 13.8 Volt DC Negative Ground

#### *Transmitter*

- Antenna Connector: UHF TYPE, 50 Ohm
- RF Transmit Modes: USB, LSB, CW, AM, FM
- RF Output Power: USB, LSB (25W); CW (8W); AM/FM (8W)
- Spurious Emissions: -50dB
- Carrier Suppression (SSB Modes): -50 dB

#### *Receiver*

- Sensitivity for 10dB SINAD: AM 0.5uV
- Sensitivity for 10dB SINAD: USB/LSB/CW 0.15uV
- Sensitivity for 12dB SINAD: FM 0.25uV
- Image Rejection Ratio: 65dB
- AGC Figure of Merit: SSB/CW/AM 80dB for 50mV for 10dB Change in Audio Output
- Audio Output Power: 2.5 Watts

## RCI-2950 Controls and Connections

### INTRODUCTION

This section explains the basic operating procedures for the RCI-2950/2970 amateur 10 meter mobile transceiver.

### CONTROL & CONNECTIONS

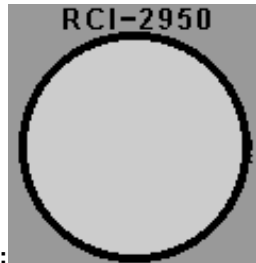

#### 1. FREQUENCY SELECTOR:

This control is used to select a desired transmit and receive frequency. It enables you to make a continuous tuning over the entire range of the transceiver.

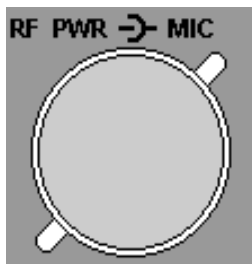

#### 2. RF POWER CONTROL:

This control enables you to adjust RF power continuously over the range of 1 watt through 25 watts (RCI-2970: 10 watts through 100 watts).

#### 3. MIC GAIN CONTROL:

This control adjusts the microphone gain in the transmit and PA modes. This feature is designed for use in a h-ambient noise environment or to maximize talk power.

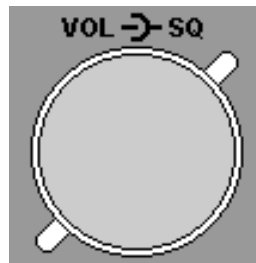

#### 4. ON/ OFF VOLUME CONTROL:

Turn clockwise to apply power to the radio and to set the desired listening level.

#### 5. SQUELCH CONTROL:

This control is used to control or eliminate receiver background noise in the absence of an incoming signal. For maximum receiver sensitivity, it is desired that the control be adjusted only to the point where the receiver background noise is eliminated. Turn fully counterclockwise then slowly turn clockwise until the receiver noise disappears. Any signal to be received must now be slightly stronger than the average received noise. Further clockwise rotation will increase the threshold level which a signal must overcome in order to be heard. Only strong signals will be heard at a maximum clockwise setting.



**6. RF GAIN CONTROL:**

This control is used to reduce the gain of the RF amplifier under strong conditions.

**7. CLARIFIER CONTROL:**

This control is used to fine tune the received signal for the maximum clarity in SSB or OW mode. It can adjust the receive frequency about + / - 500 Hz, but does not affect the transmit frequency or the frequency display.

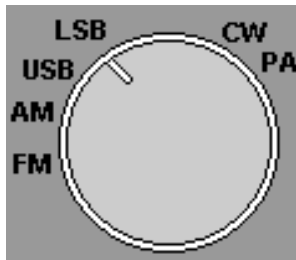

**8. MODE SWITCH:**

This switch allows you to select one of the six following operating modes: FM, AM, USB, LSB, CW, and PA.



**9. NB/ ANL BUTTON:**

The noise blanker is very effective in eliminating repetitive impulse noise such as ignition interference. In the ANL position, the automatic noise limiter in the audio circuits is activated.



**10. ROGER BEEP BUTTON:**

This button activates the ROGER BEEP Circuit when its function is selected.



**11. SPLIT BUTTON:**

This control enables you to split an operating frequency for FM Repeater operation.

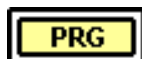

**12. PROGRAM BUTTON:**

This button is used to program operating or scanning frequencies into memory. See the OPERATION section of the manual for further details.



**13. MANUAL BUTTON:**

This is used to return the unit to manual mode.



**14. SHIFT BUTTON:**

This is used to select 100Hz, 1kHz, 10kHz, 100kHz or 1MHz frequency steps.



**15. DIM BUTTON:**

This button adjusts the display backlighting in four different steps to best match the environment.

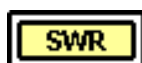

**16. SWR BUTTON:**

This control is used to check SWR.



**17. SCAN BUTTON:**

This is used to scan frequencies in each band segment. The OPERATION segment of this manual provides detailed information on using the SCAN control.



**18. MEMORY BUTTON:**

This button is used to program memory channels. Detailed information on how to use this control is provided in the OPERATION section of this manual.



**19. ENTER BUTTON:**

This is used to program frequencies in memory. See the OPERATION section of this manual for more information on using this control.



**20. LOCK BUTTON :**

This button is used to lock a selected frequency. Press it activate the switch. In this position, it disables the Frequency Selector Control, up/down buttons on the front control panel, or remote up/down buttons on the microphone. Reprising the switch will unlock the frequency.



**21. UP/ DOWN SELECTORS:**

These buttons are used to move frequency upward or downward to select a desired frequency.

**22. METER:**

This meter indicates received signal strength, transmitter RF output power and SWR level.



**23. LCD DISPLAY:**

The LCD displays the frequency selected, functions and memory channel.



**24. MIC JACK:**







Accepts 6 pin female connector with a type Philmore T6160 and Calrad 30445 to be connected.

## INTRODUCTION



This section explains the **basic programming procedures** for the RCI-2950/2970 amateur 10 meter mobile transceiver.

## FREQUENCY SELECTION

Frequency selection in the RCI-2950/2970 can be accomplished using three of the following methods:

1. The first method of frequency selection is through the use of the  (Shift) key and the  and  arrows. To accomplish this, press the  button until the cursor arrow is positioned under the digit of the frequency that is to be changed. Then use the  arrow to increase the number. If a decrease in frequency is desired, press the  arrow. Perform the steps described above for each digit of the frequency until the desired frequency is displayed in the LCD display window.

2. The second method of frequency selection is accomplished using the  button and the frequency select knob located above the microphone jack. Use the SHF button in the manner described above to select the digit to be changed. Then proceed to rotate the frequency select knob clockwise to increase the frequency. Rotate the frequency select knob counterclockwise to decrease the frequency.

3. The third method of selecting the operating frequency of the radio is through the use of the  button and the channel Up and Down button located on the microphone. Frequency selection by this method is accomplished in the same manner as with the  and  arrows on the key pad. The only difference is that the channel Up and Down buttons on the microphone are used.

While in receive mode, once a signal has been detected on a particular frequency, it may be necessary to slightly change the frequency to provide the best audio through the speaker. This can be accomplished by rotating the clarifier control to vary the

frequency by  $\pm 0.5$  kHz. After this fine tuning has been accomplished, press the  button to lock in the frequency at the point of best reception.

## FREQUENCY SCANNING

Frequency scanning can be achieved using one of two methods: the first method involves the scanning of pre-programmed memory channels; the second method will permit the user to scan all frequencies between a preset upper and lower scan limit. Both methods of frequency scanning follow.

### All Frequency Scanning

To allow All Frequency Scanning, one must first program the upper and lower scanning limits. The scan limits are simply the highest and lowest frequencies that will be scanned. To program these limits, perform the following steps:

1. Press the  (Program) key.

2. Press the  key. ("PRG SCAN+" should appear in the lower right corner of the display window.)

3. Using the **SHF** key and the  and  arrows, select the upper scan limit, then press **ENT**.

4. Press the **SCAN** key again. ("SCAN -" should appear in the display window.)

5. Using the **SHF** key and the  and  arrows, select the lower scan limit, then press **ENT**.

The upper and lower scan limits have now been programmed. To activate the scan feature, return the radio to manual operation and press the **SCAN** button. If the display shows 'SCAN the radio will scan from the lower limit to the upper limit. If "SCAN -" is displayed, the unit will scan from the upper limit to the lower limit. To change from SCAN + to SCAN - or vice versa, press **SCAN**.

**NOTE:** When programmed, the upper and lower scan limits will also act as the upper and lower operating limits of the radio. The radio cannot now be programmed to operate above or below the scan limits.



### Memory Scanning

The RCI-295012970 has 10 non-volatile (i.e\* memory resident) memory locations which can be programmed with any available frequency within the operating band of the radio. The scan function of the unit can be programmed to scan these memory channels. The radio will then scan only those memory channels which have been programmed.

The first step in utilizing the memory scan function is to program the desired frequencies into the radio memory. This can be accomplished by performing the following steps:

1. With the radio operating in the manual mode, press the **PRG** (Program) key.

2. Press the **MEM** (Memory) key. "PRG" should be displayed in the lower right-hand corner of the LCD display window. In the upper left portion of the display, "MEMORY" should be displayed. Directly below MEMORY, a number between 0 and 9 will be displayed. This number represents the memory location currently being displayed. Pressing the **MEM** key will increase the memory counter to the next memory location and the contents of that memory location will be displayed.

3. Using the **SHF** key and the  and  arrows, enter the frequency to be stored in the memory location displayed. After the desired frequency has been entered, press **ENT**.

4. Repeat steps 2 and 3 for all of the memory locations to be programmed.

5. After all desired memory locations have been programmed with frequencies, return the unit to the manual mode of operation by pressing the **MAN** key.

6. To initiate memory scanning, press **MEM** and then press **SCAN**. As previously discussed, the display will show "SCAN + " or "SCAN -" to indicate whether the radi0 is scanning from the lowest or the highest merory location or vice versa.

7. To return the radio to normal (non-scanning) operation, press the  key.

## OFFSET FREQ. OPERATION

The RCI-2950/2970 has an offset or **split frequency** feature that will permit the radio to be operated in a half-duplex mode. This will allow the user to talk on FM repeaters operating in the 10 Meter band. (NOTE: The FM repeaters may require a sub-audible (CTCSS) tone to be transmitted to gain access to the repeater. The RCI-2950 is not factory-equipped with a CTCSS encoder/decoder.) The split frequency function offsets the transmitter frequency either above or below the receive frequency by a user-programmable amount. In the following example, programming of a 100kHz offset will be described. Before attempting to program

the offset frequency, ensure that the radio is operating in the manual mode by pressing the  key.



1. Press the  key.

2. Press the  key. The LCD display window will display "00000" with "PRG" and "SPLIT" being displayed in the lower left-hand corner.

3. Using the  key and the  and  arrows as described earlier, program the display to read "010000."

4. Press . A 100kHz offset has now been programmed into the radio.

5. Return the radio to manual operation by pressing the  key.

6. Using the  key and the  and  arrows as described previously, set the radio for the desired receive frequency.

7. Press . In the lower right corner of the display, either "SPLIT +" or "SPLIT -" will be displayed. If SPLIT + is displayed, the transmitter will be offset 100kHz above the receive frequency when keyed. If SPLIT - is displayed, the transmitter will be offset 100kHz below the receive frequency.

9. **NOTE:** When the transmitter is keyed, the frequency display will change to show the frequency being transmitted.

8. To return the radio to simplex operation (i.e., same transmit and receive frequency), press the  key.

## Technical Analysis of the RCI 2950, RCI 2970, RCI 2990, Saturn Turbo circuitry

The first striking element of the RCI is the complex frequency synthesizer. As most of the CB rigs use a + 10 KHz step, the RCI uses a 100 times thinner 100 Hz step.

The brain of the RCI is the Microprocessor. The microprocessor is held by the small board located behind the LCD display. This board runs the rig. It is a double-sided board which holds a battery, an alignment of 2.54mm connectors, a voltage regulator (5V - MC7805) on its back. The regulator feeds all the digital components, a network of internal resistors. On the same side of the board, you can find a buzzer and a lithium battery which is here to keep the memories when the rig is switched off. Note that, in the latest versions of RCI rigs, the lithium battery has been replaced by a capacitor.

The other side of the board holds 3 CMS chips, a double Op-Amp (5223), a box containing 6 inverters gates (buffers) CD4069. This last one is controlling the 6 digits of the display. This side of the board also holds a 64 pins CMS chip, driven at 4 Mhz by a crystal, which is a CMOS circuit. It owns a ROM of 2 K, Four 4 bits registers, a 8 bit timer, a serial 8 bits communication interface, 24 Input/Output. Everything is controlled by 10 microseconds cycles. A controller-Driver of Liquid Display Boards is supervising all the needed display cycles on the 24 lines of the LCD segments to display the 6 numbers (7 segments by number) on the orange screen. The microprocessor is having very low consumption characteristics: less than 900  $\mu$ A.

The programming of the microprocessor is done at factory. All the functions and the frequencies range are stored into the ROM. A jumper allows us to change the frequency range. All the main informations are sent to the frequency synthesizer by a limited amount of links: clock signals (CLK), transfers (LAT), serial data (DATA). All these informations are not given by the schematic diagram but were useful to know. Let's pay a visit to the main board.

**The Frequency Synthesizer** is complex because of the 100 Hz resolution. It owns a dozen of integrated circuits: a programmable divider (IC17:7925 Sony) addressed in serial mode by the microprocessor, a first VCO (IC8: TA7310 Toshiba), two phase comparers (IC5-IC7 TC5081 Toshiba), three mixers (IC9-IC10-IC14: TA7310), an oscillator-divider driven by a 10.250 Mhz crystal. This part of the rig generates 2 different frequencies: in RC mode to get an infradyne pulse of the first conversion (RX QRG - Interm.QRG of 10.695 Mhz) and in TX, the necessary to produce a supradyn ( Interm.QRG of 10.695Mhz + FVCO). Depending of the TX mode, in AM/FM, the Q44 oscillator is controlled by X3 (10.695 Mhz). In SSB and CW, there is a 1500 Hz jump (+ 1500 Hz in USB and CW and -1500 Hz in LSB).

**The transmit circuits** follow the frequency synthesizer. It has a HF mixer (IC20 : SO42P Siemens). It is adapted in large band conditions by a set of varicaps D93-D94-D95. The result of the mixing is then applied to a band filter (L43-L46), amplifier in voltage by a transistor Q50: 2SC1730L. The output level of this TR is enough to control the pre-driver (Q49: 2SC1973). The pre-driver, via L41, excites two finals in parallel (Q46-Q47: 2SC2312). They are followed by a low-pass filter in PI (L32-L31) and associated capacitors C243-247-251). And then a hi-pass filter follows (L33/C248-VC3). A line of measurement of the SWR is present in the form of a vertical mini circuitry board, plugged between the TX output and the antenna plug. All the 3 power transistors are biased VR11. In AM and FM, the mixer IC20 adds the VCO QRG to 10.695 (Q44). In SSB and CW, it is the output of the crystal filter that is added.

**The receiver is classical:** superheterodyne with 2 IF conversions. It is very similar to the one of most cb rigs. There are output stages: HF Amp (Q18: 2SC1674), transfo L8, first mixer Q19: 310), L9-L11 filter, the IF output by L12,L13,L14. What strikes is the presence of varicaps D19,D23,D24 which works to produce a perfect tune in this large band rig. The band filtering is also perfect. It is done by two combined transfos linking the HF amp to the mixer. The ceramic IF filter FL2: 10.995 Mhz is attacked by L14. The a second stage of IF Q8 is feeding the second IF filter FL3 455 Khz. The first following TR loads Q5. Then Q10 & Q11 produce a high gain before the first IF transfo L6. The follow AM and FM demodulators. In AM you have a diode circuit to detect and gain control (D11-D12). The Op-Amp IC1: LM324 follows. IC2, is the discriminator (UPC1028H). It handles the FM.

**In SSB**, the signal from the first mixer is bandwidth reduced by FL3 then applied to the first amplification IF stage Q20. A high gain amp follows Q21-Q22-Q23. The audio output is controlled by a classical audio amp IC19 (TA7222P)

**The noise blanker** is very good. It is composed of 6 stages with at least 7 TR and 3 diodes assuming the amplification of HF interference coming from the first QRG changer.

**The AM** is using a classical and reliable technology: a ballast PNP transistor (Q51).









**In FM**, we can find the old good MC14558P (IC16) which handles modulation of the mike before exciting the varicap of the VCO to produce frequency excursions.







**In SSB**, IC16 pre-amplifies the mike signals. It is followed by IC3 (AN612) which produces a double side band modulation (DSB). Once going through the crystal filter, the un-wanted side band is eliminated.





You now know more about the hidden components of your RIG.





[www.radioaficion.com](http://www.radioaficion.com)



### Transistor Voltage Chart





Ref #	Function	Part #			LOC	B	C	E
Q1		2SC1675L	NPN		B-3	0.00NB Off	0.00 NB Off	0.00 NB Off
						1.77NB On	7.67 NB On	1.06NB On
Q2		2SC1675L	NPN		C-2	0.00NB Off	0.00 NB Off	0.00NB Off
						0.71NB On	2.09 NB On	0.00NB On
Q3		2SC945	NPN		C-3	0.00NB Off	0.00NB Off	0.00NB Off
						2.09NB On	7.76 NB On	1.45NB On
Q4		2SC945	NPN		B-2	0.00NB Off	8.01 NB Off	0.01NB Off
						0.02NB On	8.01 NB On	1.06NB On
Q5		2SC945	NPN		C-3	0.00NB Off	7.37 NB Off	0.01NB Off
						0.01NB On	7.37 NB On	0.03NB On
Q6		2SA733	PNP		C-2	7.36NB Off	0.00 NB Off	8.01NB Off
						7.36NB On	0.00 NB On	8.01NB On
Q7		2SC945	NPN		C-2	0.00NB Off	0.00 NB Off	0.00NB Off
						0.00NB On	0.01 NB On	0.00NB On
Q8		2SC1674	NPN		D-2	1.18 AM RX	6.93 AM RX	0.48AM RX
						0.02 AM TX	0.03 AM TX	2.44AM TX
						1.18FM RX	6.93FM RX	0.48FM RX
						0.01FM TX	0.02FM TX	2.44FM TX
						1.30SSB RX	7.60 SSB RX	2.38SSB RX





						0.01SSB TX	0.02 SSB TX	2.44SSB TX
<b>Q9</b>		2SC1675	NPN		D-3	0.71AM / FM RX	3.04AM / FM RX	0.00AM / FM RX
						0.01AM / FM TX	0.03AM / FM TX	0.00AM / FM TX
						0.82 SSB RX	0.03 SSB RX	0.00SSB RX
						0.81SSB TX	0.02 SSB TX	0.00SSB TX
<b>Q10</b>		2SC1675	NPN		D-4	3.03AM / FM RX	5.76AM / FM RX	2.26AM / FM RX
						0.02AM / FM TX	0.02AM / FM TX	0.01AM / FM TX
						0.03SSB RX	8.02 SSB RX	0.00SSB RX
						0.02SSB TX	0.02 SSB TX	0.01SSB TX
<b>Q11</b>		2SC1675L	NPN		D-4	2.26AM / FM RX	5.49AM / FM RX	1.52AM / FM RX
						0.01AM / FM TX	0.02AM / FM TX	0.01AM / FM TX
						0.00 SSB RX	8.02 SSB RX	0.01SSB RX
						0.01 SSB TX	0.02 SSB TX	0.01SSB TX
<b>Q12</b>		2SA733	PNP		B-4	8.02NB Off	0.00 NB Off	8.06NB Off
						7.35NB On	8.01 NB On	8.06NB On
<b>Q13</b>		2SC945	NPN		B-4	0.00AM / FM RX	-0.25AM / FM RX	0.00AM / FM RX
						0.01AM / FM TX	-0.24AM / FM TX	0.00AM / FM TX
						0.71 SSB RX	0.01 SSB RX	0.00 SSB RX
						0.71 SSB TX	0.01 SSB TX	0.00SSB TX
<b>Q14</b>		2SC945	NPN		B-4	0.70AM / FM RX	0.01AM / FM RX	0.00AM / FM RX
						0.71AM / FM TX	0.02AM / FM TX	0.00AM / FM TX





						0.01 SSB RX	0.11 SSB RX	0.00 SSB RX
						0.01SSB TX	0.01 SSB TX	0.00SSB TX
<b>Q15</b>		2SC945	NPN		E-4	0.01AM / FM RX	0.02AM / FM RX	0.00AM / FM RX
						0.01AM / FM TX	0.01AM / FM TX	0.00AM / FM TX
						0.70 SSB RX	0.01 SSB RX	0.00 SSB RX
						0.71SSB TX	0.01 SSB TX	0.00SSB TX
<b>Q16</b>		2SC945	NPN		E-5	1.26AM / FM RX	5.04AM / FM RX	0.68AM / FM RX
						1.26AM / FM TX	5.05AM / FM TX	0.68AM / FM TX
						1.26 SSB RX	5.01 SSB RX	0.68 SSB RX
						1.26SSB TX	5.01 SSB TX	0.68SSB TX
<b>Q17</b>		2SC945	NPN		B-2	0.00AM / FM RX	0-0.01AM / FM RX	0.00AM / FM RX
						0.76 SSB TX	0.02 SSB TX	0.00SSB TX
<b>Q18</b>		2SC1674	NPN		C-2	2.15 AM RX	7.73 AM RX	1.41AM RX
						0.02 AM TX	0.03 AM TX	0.01AM TX
						2.15 FM RX	7.73 FM RX	1.41FM RX
						0.03 FM TX	0.08 FM TX	0.01FM TX
						2.16 SSB RX	7.74 SSB RX	1.41 SSB RX
						0.01 SSB TX	0.02 SSB TX	0.01SSB TX
<b>Q19</b>		J310	FET		D-3	0.03AM / SSB RX	7.95AM / SSB RX	1.89AM / SSB RX
						0.01AM / SSB TX	0.02AM / SSB TX	0.03AM / SSB TX
						0.00 FM RX	7.95 FM RX	1.90FM RX



						0.01 FM TX	0.07 FM TX	0.07FM TX
<b>Q20</b>		2SC1674	NPN		D-4	0.95 AM RX	0.24 AM RX	0.23AM RX
						3.41 AM TX	3.02 AM TX	7.34AM TX
						0.95 FM RX	0.24 FM RX	0.23 FM RX
						1.66 FM TX	1.19 FM TX	7.35FM TX
						1.60 SSB RX	6.69 SSB RX	0.85 SSB RX
						3.40 SSB TX 3.42 With MOD	7.11 SSB TX 7.13 With MOD	7.34 SSB TX 7.36 With MOD
<b>Q21</b>		2SC1675	NPN		D-4	0.22AM / FM RX	1.74AM / FM RX	0.00AM / FM RX
						0.02AM / FM TX	0.03AM / FM TX	0.00AM / FM TX
						0.73 SSB RX	3.43 SSB RX	0.00 SSB RX
						0.01 SSB TX 0.03 With MOD	0.02 SSB TX 0.04 With MOD	0.00 SSB TX
<b>Q22</b>		2SC1675	NPN		D-4	1.74AM / FM RX	0.93AM / FM RX	0.92AM / FM RX
						0.03AM / FM TX	0.40AM / FM TX	0.02AM / FM TX
						3.43 SSB RX	6.52 SSB RX	2.66 SSB RX
						0.02 SSB TX 0.04 With MOD	7.09 SSB TX 7.16 With MOD	0.01 SSB TX 0.03 With MOD
<b>Q23</b>		2SC1906	NPN		D-4	3.92AM / FM RX	7.78AM / FM RX	0.23AM / FM RX
						0.02AM / FM TX	0.02AM / FM TX	0.02AM / FM TX
						2.65 SSB RX	6.10 SSB RX	1.90 SSB RX
						0.01 SSB TX 0.02 With MOD	0.02 SSB TX 0.04 With MOD	0.01 SSB TX 0.03 With MOD
<b>Q24</b>		2SC945	NPN		D-2	0.70 AM RX	0.01 AM RX	0.00AM RX

					0.71 AM TX	0.02 AM TX	0.00AM TX
					0.01 FM RX	0.18 FM RX	0.00FM RX
					0.02 FM TX	0.05 FM TX	0.00FM TX
					0.01 SSB RX	0.01 SSB RX	0.00 SSB RX
					0.01 SSB TX 0.03 With MOD	0.02 SSB TX 0.20 With MOD	0.00 SSB TX
<b>TR25</b>		2SA733	PNP	 D-1	ANL 8.01 AM RX ON 6.72 OFF	ANL 0.16 AM RX ON 7.38 OFF	ANL 8.05 AM RX ON 7.38 OFF
					ANL 8.02 AM TX ON 6.73 OFF	ANL 0.22 AM TX ON 7.38 OFF	ANL 8.06 AM TX ON 7.39 OFF
					ANL 0.01 FM RX ON 0.01 OFF	ANL 0.01 FM RX ON 0.01 OFF	ANL 0.01 FM RX ON 0.01 OFF
					ANL 0.02 FM TX ON 0.02 OFF	ANL 0.02 FM TX ON 0.02 OFF	ANL 0.02 FM TX ON 0.02 OFF
					ANL 0.01 SSB RX ON 0.01 OFF	ANL 0.01 SSB RX ON 0.01 OFF	ANL 0.01 SSB RX ON 0.01 OFF
					ANL 0.02 SSB TX ON 0.02 OFF	ANL 0.01 SSB TX ON 0.01 OFF	ANL 0.01 SSB TX ON 0.01 OFF
<b>Q26</b>		2SC945	NPN	 D-1	AM / FM / SSB RX 2.82	AM / FM / SSB RX 7.19	AM / FM / SSB RX 2.28
					AM / FM / SSB TX 2.84	AM / FM / SSB TX 7.20	AM / FM / SSB TX 2.29
<b>Q27</b>		2SC1675	NPN	 C-5	AM / FM / SSB RX 3.44	AM / FM / SSB RX 5.93	AM / FM / SSB RX 2.70
					AM / FM / SSB TX 3.45	AM / FM / SSB TX 5.94	AM / FM / SSB TX 2.71





<b>Q28</b>		2SC1675	NPN		D-4	AM / FM / SSB RX 0.72	AM / FM / SSB RX 4.36	AM / FM / SSB RX 0.00
						AM / FM / SSB TX 0.72	AM / FM / SSB TX 4.37	AM / FM / SSB TX 0.00
<b>Q29</b>		2SC1675	NPN		E-6	0.01 AM RX	7.95 AM RX	0.00AM RX
						0.02 AM TX	7.96 AM TX	0.00AM TX
						0.75 FM RX	0.02 FM RX	0.00FM RX
						0.79 FM TX	0.07 FM TX	0.00FM TX
						0.01 SSB RX	7.94 SSB RX	0.00 SSB RX
						0.01 SSB TX	7.95 SSB TX	0.00SSB TX
<b>Q30</b>		2SC945	NPN		F-1	0.71AM / FM RX	0.02AM / FM RX	0.00AM / FM RX
						0.72AM / FM TX	0.03AM / FM TX	0.00AM / FM TX
						0.01 SSB RX	2.95 SSB RX	0.00 SSB RX
						0.01 SSB TX 0.03 With MOD	2.89 SSB TX 2.91 With MOD	0.00
<b>Q31</b>		2SA733	PNP		B-3	8.02 AM RX	0.11 AM RX	8.06AM RX
						8.02 AM TX	-0.34 AM TX	8.06AM TX
						8.02 FM RX	0.11 FM RX	8.06FM RX
						8.02 FM TX	-0.39 FM TX	8.06FM TX
						8.02 SSB RX	-0.11 SSB RX	8.06 SSB RX
						8.02 SSB TX 6.95 With MOD	-0.43 SSB TX 5.46 With MOD	8.05 SSB TX 7.57 With MOD
<b>Q32</b>		2SA945	NPN		F-6	AM / FM / SSB RX 0.71	AM / FM / SSB RX 0.01	AM / FM / SSB RX 0.00

						AM / FM / SSB TX 0.01 0.50 With MOD	AM / FM / SSB TX 0.01	AM / FM / SSB TX 0.00
<b>Q33</b>		2SC945	NPN		E-6	AM / FM / SSB RX 0.24	AM / FM / SSB RX 0.25	AM / FM / SSB RX 0.00
						AM / FM / SSB TX 0.57 0.58 SSB MOD	AM / FM / SSB TX 0.72 0.74 SSB MOD	AM / FM / SSB TX 0.00
<b>Q34</b>		2SC945	NPN		F-6	AM / FM / SSB RX 0.00	AM / FM / SSB RX 1.32	AM / FM / SSB RX 0.00
						AM / FM / SSB TX 0.00 0.01 SSB MOD	AM / FM / SSB TX 0.01 0.94 AM/SSB MOD	AM / FM / SSB TX 0.00
<b>Q35</b>		2SA733	PNP		C-5	AM / FM / SSB RX 8.02R.B. Off	AM / FM / SSB RX 3.05R.B. Off	AM / FM / SSB RX 8.06R.B. Off
						AM / FM / SSB TX 8.03R.B. Off	AM / FM / SSB TX -0.70R.B. Off	AM / FM / SSB TX 8.07R.B. On
						AM / FM / SSB RX 7.41R.B. On	AM / FM / SSB RX 8.05R.B. On	AM / FM / SSB RX 8.06R.B. On
						AM / FM / SSB TX 7.42R.B. On	AM / FM / SSB TX 8.06R.B. On	AM / FM / SSB TX 8.07R.B. On
<b>Q36</b>		2SC945	NPN		C-6	AM / FM / SSB RX 0.01	AM / FM / SSB RX 8.03	AM / FM / SSB RX 0.01
						AM / FM / SSB TX 0.02	AM / FM / SSB TX 8.04	AM / FM / SSB TX 0.35
<b>Q37</b>		2SA1282	PNP		D-6	AM / FM / SSB RX 7.36	AM / FM / SSB RX 0.02	AM / FM / SSB RX 8.06
						AM / FM / SSB TX 8.05	AM / FM / SSB TX 8.04	AM / FM / SSB TX 0.35
<b>Q38</b>		2SA1282	PNP		C-6	8.02AM RX	0.00AM RX	8.06AM RX
						7.27AM TX	7.95AM TX	8.05AM TX
						8.02 FM/SSB RX	0.00 FM/SSB RX	8.06 FM/SSB RX

						7.28 FM/SSB TX	7.96 FM/SSB TX	8.04FM/SSB TX
<b>Q39</b>		2SC945	NPN		A-2	AM / FM / SSB RX 0.63	AM / FM / SSB RX 0.05	AM / FM / SSB RX 0.00
						AM / FM / SSB TX 0.01	AM / FM / SSB TX 8.04	AM / FM / SSB TX 0.00
<b>Q40</b>		2SA1282	PNP		A-1	AM / FM / SSB RX 7.54	AM / FM / SSB RX 0.28	AM / FM / SSB RX 8.05
						AM / FM / SSB TX 7.35	AM / FM / SSB TX 8.04	AM / FM / SSB TX 8.06
<b>Q41</b>		2SC945	NPN		B-1	AM / FM / SSB RX 0.00	AM / FM / SSB RX 0.29	AM / FM / SSB RX 0.00
						AM / FM / SSB TX 0.01	AM / FM / SSB TX 3.15	AM / FM / SSB TX 0.00
						0.70 CW Mode RX	0.01 CW Mode RX	0.00CW Mode RX
						0.71 CW Mode TX	0.02 CW Mode TX	0.00CW Mode TX
<b>Q42</b>		2SC945	NPN		B-1	AM / FM / SSB RX 0.77	AM / FM / SSB RX 1.65	AM / FM / SSB RX 0.15
						AM / FM / SSB TX 0.78	AM / FM / SSB TX 1.65	AM / FM / SSB TX 0.16
<b>Q43</b>		2SC1675	NPN		B-3	0.00AM / FM RX	8.04AM / FM RX	5.06AM / FM RX
						0.01AM / FM TX	8.04AM / FM TX	5.05AM / FM TX
						0.00 SSB RX	8.04 SSB RX	0.30 SSB RX
						0.01 SSB TX 0.07 With MOD	8.04 SSB TX 5.60 With MOD	0.30 SSB TX 1.05 With MOD
<b>Q44</b>		2SC1675	NPN		B-6	0.02AM / FM RX	0.03AM / FM RX	0.01AM / FM RX
						2.12AM / FM TX	4.56AM / FM TX	1.41AM / FM TX
						2.10 SSB RX	4.54 SSB RX	1.38 SSB RX

						2.12 SSB TX	4.57 SSB TX	1.40 SSB TX
<b>Q45</b>		2SA733	PNP		B-6	AM / FM / SSB RX 8.04	AM / FM / SSB RX 0.01	AM / FM / SSB RX 0.00
						AM / FM / SSB TX 8.05	AM / FM / SSB TX 0.02	AM / FM / SSB TX 0.01
						8.04 CW Mode RX	0.00 CW Mode RX	8.04 CW Mode RX
						4.91 CW Mode TX	5.54 CW Mode TX	5.58 CW Mode TX
<b>Q46</b>		2SC2312	NPN		B-6	0.00 AM / FM RX	4.15 AM / FM RX	0.00 AM / FM RX
						0.68 AM / FM TX	3.80 AM / FM TX	0.00 AM / FM TX
						0.00 SSB RX	13.25 SSB RX	0.00 SSB RX
						0.68 SSB TX 0.71 With MOD	12.60 SSB TX 15.11 With MOD	0.00
<b>Q47</b>		2SC2312	NPN		A-6	0.00 AM / FM RX	4.15 AM / FM RX	0.00 AM / FM RX
						0.58 AM / FM TX	3.80 AM / FM TX	0.00 AM / FM TX
						0.00 SSB RX	13.25 SSB RX	0.00 SSB RX
						0.68 SSB TX 0.71 With MOD	12.60 SSB TX 15.11 With MOD	0.00
<b>Q48</b>		2SC2166	NPN		B-4	0.00 AM / FM RX	4.15 AM / FM RX	0.00 AM / FM RX
						0.74 AM / FM TX	3.88 AM / FM TX	0.00 AM / FM TX
						0.00 SSB RX	13.25 SSB RX	0.00 SSB RX
						0.74 SSB TX	12.75 SSB TX	0.00
<b>Q49</b>		2SC2314	NPN		B-4	0.00 AM / FM RX	0.00 AM / FM RX	0.00 AM / FM RX
						1.25 AM / FM TX	8.30 AM / FM TX	0.70 AM / FM TX

						0.00 SSB RX	0.00 SSB RX	0.00 SSB RX
						1.28 SSB TX 1.30 With MOD	7.95 SSB TX 8.06 With MOD	0.57 SSB TX 0.59 With MOD
<b>Q50</b>		2SC1906	NPN		B-4	0.00AM / FM RX	0.00AM / FM RX	0.00AM / FM RX
						1.41AM / FM TX	7.95AM / FM TX	0.71AM / FM TX
						0.00 SSB RX	0.00 SSB RX	0.00 SSB RX
						1.45 SSB TX	7.95 SSB TX 7.97 With MOD	0.66 SSB TX 0.69 With MOD
<b>Q51</b>		2SB754	PNP		B-4	13.31AM / FM RX	4.29 AM / FM RX	13.79AM / FM RX
						12.74AM / FM TX	3.43AM / FM TX	13.57AM / FM TX
						13.25 SSB RX	13.25 SSB RX	13.79 SSB RX
						12.80 SSB TX 12.15 With MOD	12.80 SSB TX 12.13 With MOD	13.66 SSB TX 13.39 With MOD
<b>Q52</b>		2SC945	NPN		B-4	4.03AM / FM RX	13.30AM / FM RX	4.10AM / FM RX
						4.03AM / FM TX	12.15AM / FM TX	3.48AM / FM TX
						12.27 SSB RX	12.63 SSB RX	12.85 SSB RX
						11.75 SSB TX 11.23 With MOD	12.30 SSB TX 11.52 With MOD	12.55 SSB TX 11.79 With MOD
<b>Q53</b>		2SA473	PNP		B-4	13.30AM / FM RX	4.29AM / FM RX	13.31AM / FM RX
						12.15AM / FM TX	3.43AM / FM TX	12.74AM / FM TX
						12.63 SSB RX	13.25 SSB RX	13.25 SSB RX
						12.30 SSB TX 11.52 With MOD	12.80 SSB TX 12.13 With MOD	12.80 SSB TX 12.15 With MOD
<b>Q54</b>		2SC945	NPN		B-4	0.00 AM / FM RX	13.30AM / FM RX	0.00AM / FM RX

					0.02 AM / FM TX	12.18AM / FM TX	0.00AM / FM TX
					0.73 SSB RX	0.05 SSB RX	0.00 SSB RX
					0.73 SSB TX 0.75 With MOD	0.05 SSB TX 0.07 With MOD	0.00 SSB TX
<b>Q55</b>		2SC945	NPN	 B-4	0.63AM / FM RX	8.05AM / FM RX	0.53 AM / FM RX
					0.64 AM / FM TX	8.05AM / FM TX	0.43AM / FM TX
					0.63 SSB RX	8.05 SSB RX	1.65 SSB RX
					0.63 SSB TX 0.63 With MOD	8.05 SSB TX 6.90 With MOD	0.63 SSB TX 0.63 With MOD
<b>Q56</b>		2SC945	NPN	 B-4	0.71AM / FM RX	0.01AM / FM RX	0.00AM / FM RX
					0.72 AM / FM TX	0.02AM / FM TX	0.00AM / FM TX
					0.71 SSB RX	0.01SSB RX	0.00 SSB RX
					0.71 SSB TX 0.73 With MOD	0.01 SSB TX 0.03 With MOD	0.00 SSB TX
<b>Q57</b>		2SC945	NPN	 B-4	0.69 AM RX	0.02 AM RX	0.00 AM RX
					0.70 AM TX	0.03 AM TX	0.00 AM TX
					0.00 FM RX	0.71 FM RX	0.00 FM RX
					0.02 FM TX	0.72 FM TX	0.00 FM TX
					0.00 SSB RX	0.71 SSB RX	0.00 SSB RX
					0.01 SSB TX 0.03 With MOD	0.72 SSB TX 0.73 With MOD	0.00 SSB TX
<b>Q58</b>		2SC945	NPN	 B-4	0.01 AM RX	0.01 AM RX	0.01 AM RX
					0.02 AM TX	0.02 AM TX	0.02 AM TX
					1.02 FM RX	4.32 FM RX	0.38 FM RX

1.03 FM TX	4.32 FM TX	0.40FM TX
0.01 SSB RX	0.01 SSB RX	0.01 SSB RX
0.01 SSB RX	0.01 SSB RX	0.01 SSB RX

[www.radioaficion.com](http://www.radioaficion.com)

## RCI SECRETS

Just want to toss a couple radio mods and secrets to You,and if any are fit to print-then please do so!!!

**# 1-RCI-2950>> R247** should be a 4.7k ohm resistor...the factory accidentally put in 47k ohm in some units...this will hurt LSB performance if not corrected....

**# 2-RCI-2950>> R78** is a 2.2k ohm resistor...changing this to a 6.8k 1/4 watt resistor will improve receiver performance in all modes,and help with the RF gain control operation as well

**# 3-RCI-2950>> R291** is the A.M. modulation limiter...removing this will boost A.M. only,and will not affect or cause SSB overmodulation...

**# 4-RCI-2950>>** To allow clarifier to slide in transmit and receive...Remove D59 and R197,take a 5" piece of INSULATED wire and strip both ends,connect one end to the LEFT hole of the removed R197,connect other end to the far right hole of the unused 4 hole box located to the right of Q33 and right behind D75...solder these 2 connections carefully!!!

**# 6-Galaxy Rigs** (models with the EPT360014B boards)>>To boost A.M. modulation,do NOT cut or remove TR-32!!!This can adversely affect SSB,causing overmodulation and severe splatter!!!!The proper way to boost A.M.,is cut one end of R249,and remove TR53 from the board..this will really boost the A.M.,but has NO affect on SSB..

**# 7-Galaxy Rigs>>** A certain Service Manual(I will not name it as to prevent any lawsuits!!),incorrectly lists the proper alignment cans for A.M. and SSB center frequency operation...Can L19 is the A.M. RX freq. adjustment,L20 is USB adjustment,and L21 is for LSB...turning the wrong cans in that cluster of tuning cans will prove to make for a REAL BAD DAY!!!!!!!

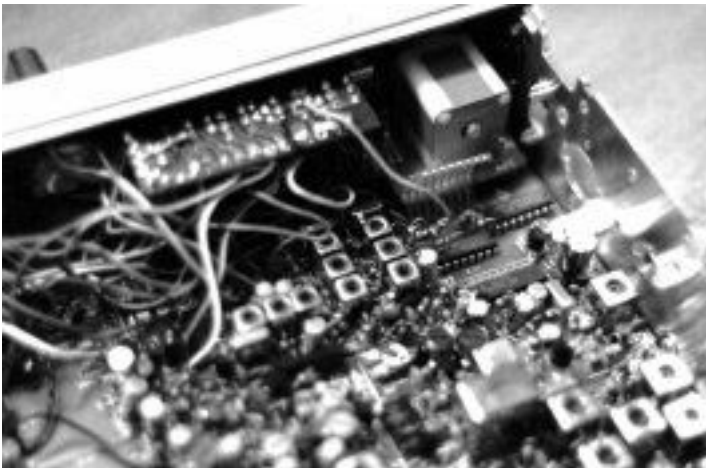

### RANGER RCI-2950

Extended Frequency Modification: On microprocessor board locate the double two pin headers and shunt near the center of the board. Move the shunt jumper to the other two-pin header right next to the original position. The new range of frequencies is 26.000-29.700Mhz.

D87 & D111 are responsible for FM deviation. 10uF was installed across R308 for more deviation.

J54 was used as of a source for a transmit B+ signal that was routed through a small choke and then to the output SO-239 connector to supply the amplifier with a multiplexed RF/keying signal.

A 5V dip relay was used and the coil powered from the anode of D107 to allow a parallel combination of 3300uF and 47/2W resistor to be switched into series with the two final output transistors in the AM mode only. This produced an AM swing from 100mW to about 4.5W

## **COMPARED**

There is a big difference between the RCI 2990/Galaxy Saturn Turbo and the Galaxy Saturn.

The Galaxy Saturn is a Galaxy DX-88 in a box with 2 meters and a power supply. The frequency stability in the Galaxy Saturn, as with most other Galaxies, isn't the best.

The Galaxy Saturn \_Turbo\_ and the RCI-2990 are the same radio, albeit the different name and the Galaxy Saturn Turbo comes with CB band enabled.

I have a Turbo and my neighbor has a Saturn, and in my opinion the Turbo/2990 is much, much more radio.

The Galaxy DX-11B is much like the Turbo/2990, with more echo controls on the front.

The Galaxy DX-22B is also like the Turbo, with no linear after it (so maybe 30-40 watts or so out, versus 120+ out of the Turbo).

## **AGAIN**

I was looking at the am det mod upgrade for the 2950... The radio I am working on already has 1N60 diodes for d35-d34 , is this a mod that was done at the factory?

The bulletin should be rewritten to say what #diodes are there now and what they should be replaced with.....

The problem that is manifesting itself as AM distortion ( and TX bleed) is caused by the lack of bandwidth control due to the fact of the cheap Xtal filter they use...

I improved the Am on my set by simply putting in a 0.02 Mfd NPO cap at the AM det output diode to ground... This narrows the bandwidth improves the S/NR and cuts some of the high freq audio distortion out and provides smoothing and harmonic reduction from the AM det....

I further improved both the AM and SSB RX (and TX Bleed) by changing the Xtal IF filter... This mod will also increase AGC cut back from sig on other ch and improve S/NR and sensitivity on all bands....

With these mods, realignment and installing a cascade RF RX amp makes the RCI 2950 Rx decent.....

## REPAIR TRICKS

### **FRONT END PROTECTION DIODES**

These diodes go out when the radio is subject to an extremely strong input signal. If the radio doesn't receive or quits receiving after you unkey, **check D21 & D22**. These ones are 1N914 or 1N4148. They cost very few.

*: Need Help.. My Galaxy's receive is almost gone! I still get some rec. but it's fading.  
: It worked fine until a nearby radio keyed and then?  
: Any suggestions?*

*On the RCI 2950 you would need to check D21 & D22. On the Galaxy Saturn after comparing the two schematics it appears to be D33 and possibly R263 and R142. I would check these for any burning or for function.*

### **FREQUENCY SELECTION**

Frequency selection doesn't work properly. Locate R611 which is a 47 K $\Omega$  resistor located on the vertical CPU board on trace side. Change out with a 10 K quarter watt resistor.

### **COMMON FAULTS**

Older 2950's with batter backup will discharge the battery if the power source is removed and the radio is left in the "ON" position. This causes corruption in the memory circuits and in the microprocessor. This can cause the failure to turn on.... lights on... and nothing else.

Also found other faults:

- The 8 volt regulator that is on the left side of the radio (speaker side up, front closest to you) the regulator favors the front of the radio....anyhow... I have seen 3 or 4 radios that had the turn on with no receive or transmit. The cause: cold solder joint on the regulator, this could be caused by the stressing of the chassis during mobile installation or dropping, bumping of the radio. The cure: remove old solder from regulator and resolder. Don't attempt to remove the regulator from the chassis, it's attached there for a reason... heatsink....

One other fault:

- Warbaling on ssb.... Be sure to use the proper power cord that came with the radio... don't use the radio shack substitution. The wire gauge is smaller and thus won't be able to pass enough current thru the wires. This causes the warbaling effect on ssb. Also try turning down the mic gain on ssb when running a power mic.

- Wire the radio backwards (reverse polarity) usually causes the power regulator for AM to short out. This will give the radio a 40 Watt carrier with no modulation. This is not to be done intentionally.... just letting you know what the radio is able to do without power control.

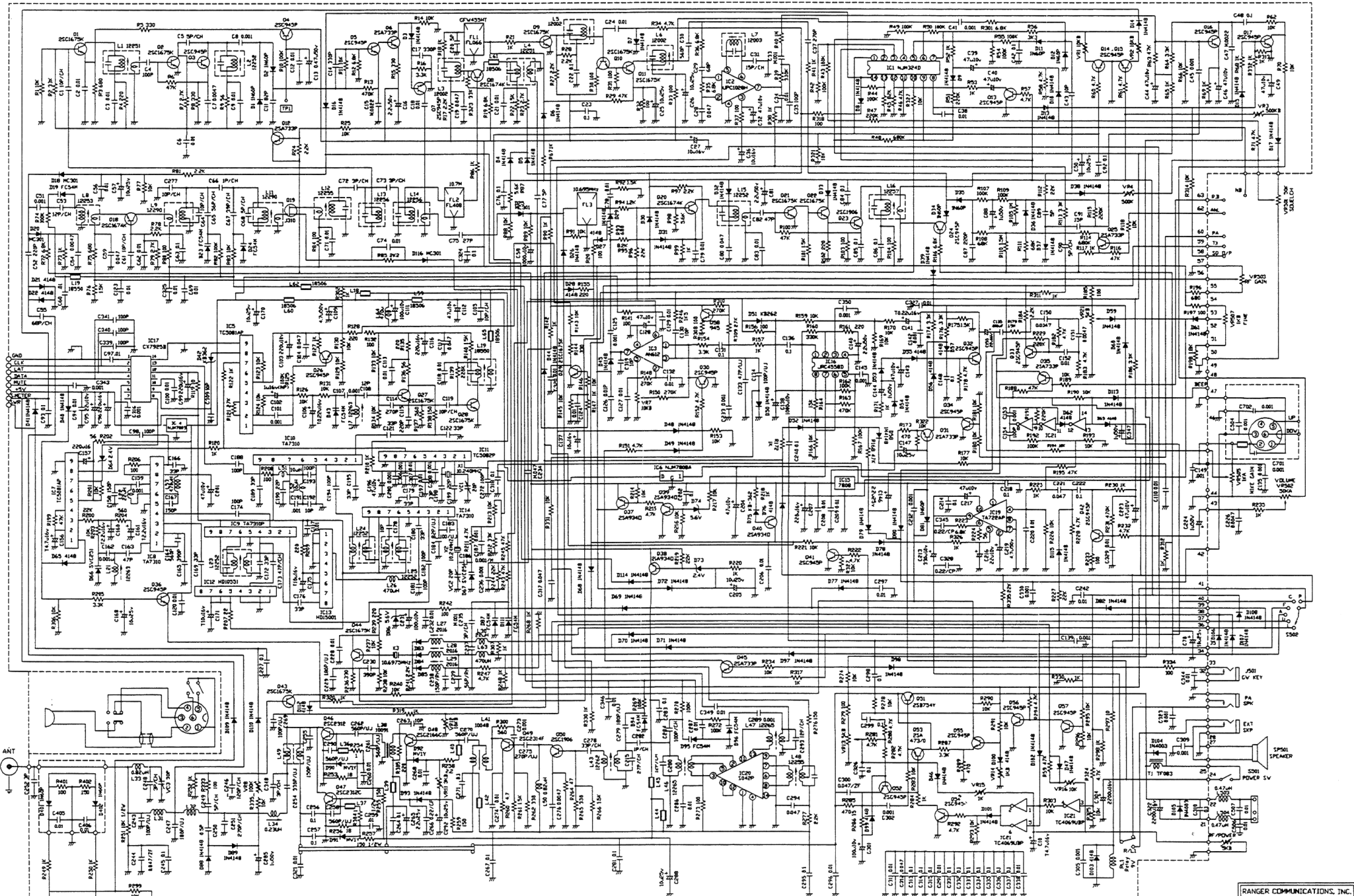

RANGER COMMUNICATIONS, INC.  
MODEL RCI-2950 MAIN  
TITLE SCHEMATIC DIAGRAM  
CHECKED 6/16/95 DRAWER KC  
APPROVED [Signature] ITEM NO. 1-1993

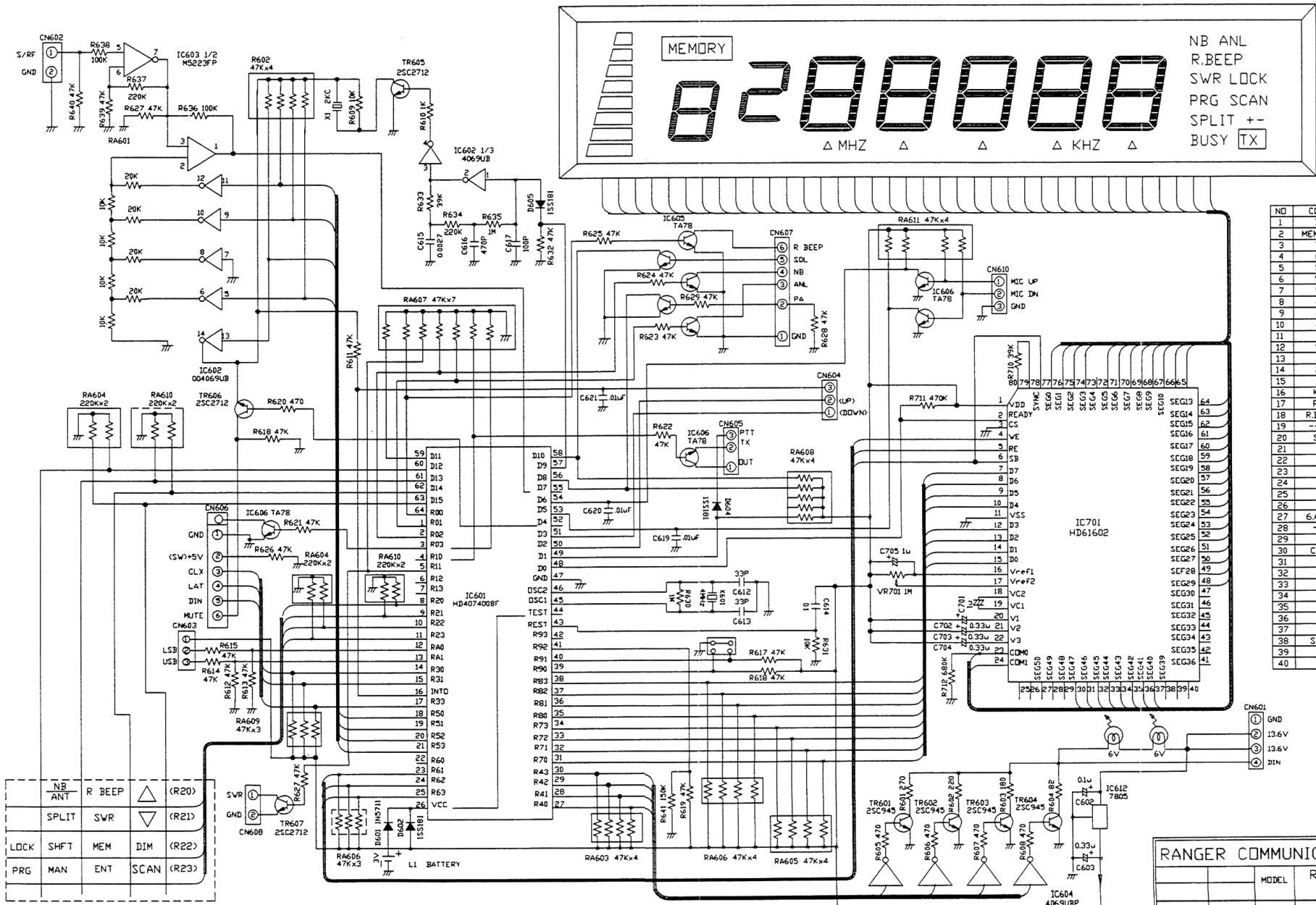

NO	CDM0	CDM1
1	7G	7E
2	MEMORY	7A
3	7B	7F
4	6C	6E
5	5B	5F
6	5G	5E
7	5C	5D
8	4B	4F
9	4G	4E
10	4P	4A
11	3B	3F
12	3G	3E
13	2B	2F
14	2G	2E
15	1B	1F
16	KHZ	NB
17	PRG	LOCK
18	R.BEEP	ANL
19	---	---
20	SWR	SCAN
21	B8	B7
22	B6	B6
23	B4	B3
24	B2	B1
25	7C	7D
26	5P	5A
27	6.ABDG	MHZ
28	---	CDM1
29	4C	4D
30	3C	3D
31	3P	3A
32	2C	2D
33	2P	2A
34	1P	1A
35	1G	1E
36	1C	1D
37	1P	1A
38	SPLIT	BUSY
39	TX	---
40	+	-

NB ANL	R BEEP	(R20)
SPLIT	SWR	(R21)
LOCK	SHFT	MEM
PRG	MAN	ENT
		SCAN (R23)

RANGER COMMUNICATIONS, INC.			
MODEL	RCI-2950/2970 (CONTROL)		
TITLE	SCHEMATIC DIAGRAM		
APPROVED	CHECKED	DRAWER	ITEM NO
	6/16/95	M.G.	

BILL OF MATERIAL

No.	PART NUMBER	Qt'y	No.	PART NUMBER	Qt'y
1	PT2950051A	1	31	MT3600030A	1
2	PT2950071A	3	32	XZZ290188Z	4
3	PT2950080A	3	33	XZZ290007Z	4
4	JS033006MN	4	34	JN263035ZS	4
5	JS053010MN	2	35	MT2950031A	1
6	EX01N4008I	8	36	MT1200060N	2
7	EPT295031Z	1	37	XZZ290006Z	3
8	PT2950041A	1	38	EPT1200060Z	1
9	JS053006MN	20	39	XZZ290004Z	1
10	MT2950010P	1	40	EPT295013Z	1
11	RV10203456	1	41	JS0530601N	5
12	EPT295060Z	1	42	EPY360040Z	1
13	EWRT32053S	1	43	EX06N40007	1
14	RV10203451	1	44	MT3600050X	1
15	EPT295090Z	1	45	EX06N41019	1
16	EPT295050Z	1	46	XZZ290098Z	1
17	RV50303453	1	47	ENHI74008F	1
18	EPT295043Z	1	48	EPT295070Z	1
19	EPT295080Z	1	49	EX06N41111	1
20	MT3600022X	1	50	EWRT32051S	1
21	JN242012ZS	3	51	EPT295090A	1
22	XZZ290003Z	3	52	EPT295021Z	1
23	XZZ290020Z	3	53	EX03N4043B	1
24	MM7878040X	1	54	EWPS33042X	14
25	JS013008TN	2	55	OT2950010A	1
26	JS052012MN	3	56	PT2950030A	1
27	JS053008MN	4	57	PT2950090A	1
28	MT2950041A	1	58	PT2950010A	1
29	LZZ260056Z	1	59	PT2950060A	1
30	ES30083550	1	60		

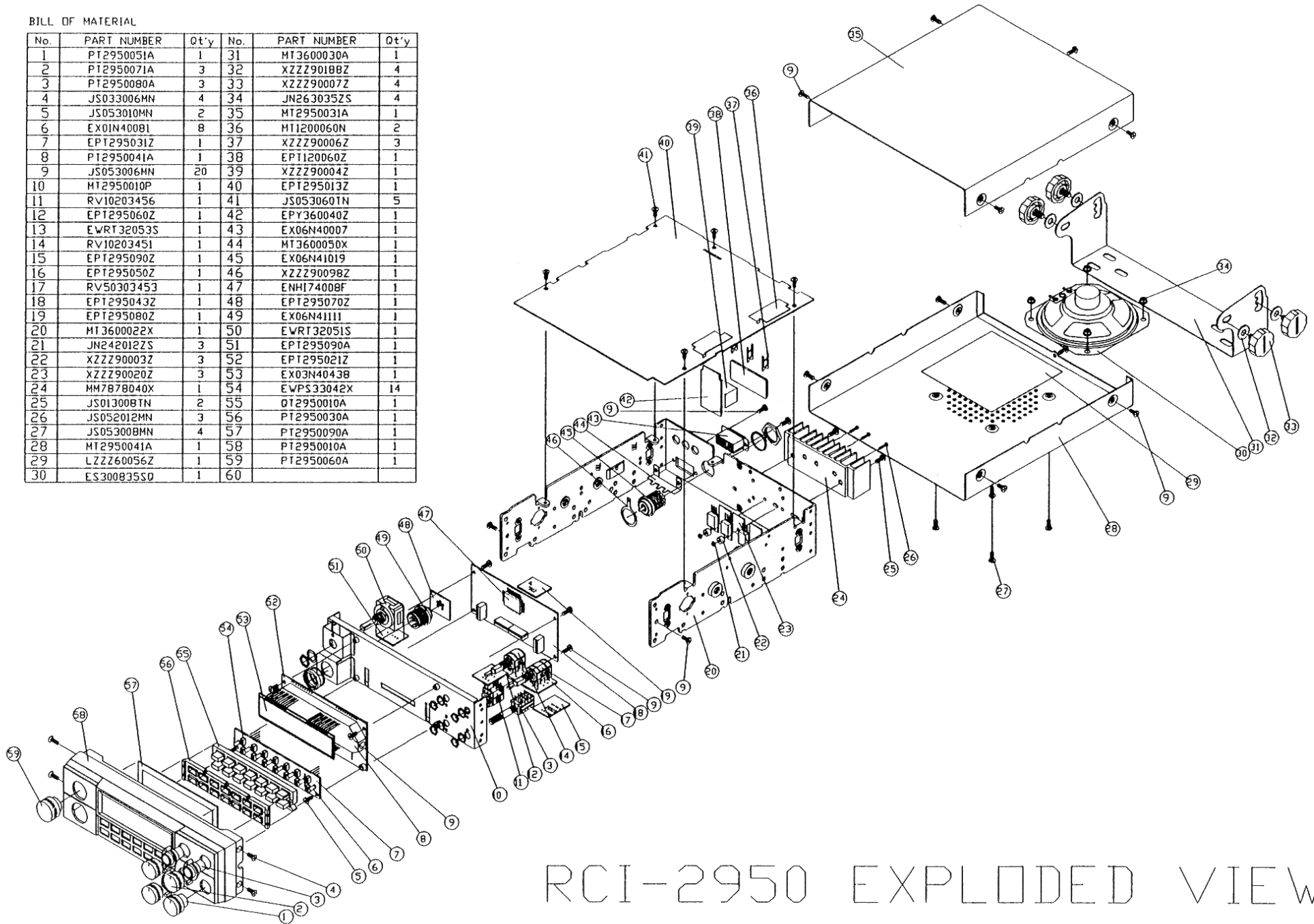

RCI-2950 EXPLODED VIEW

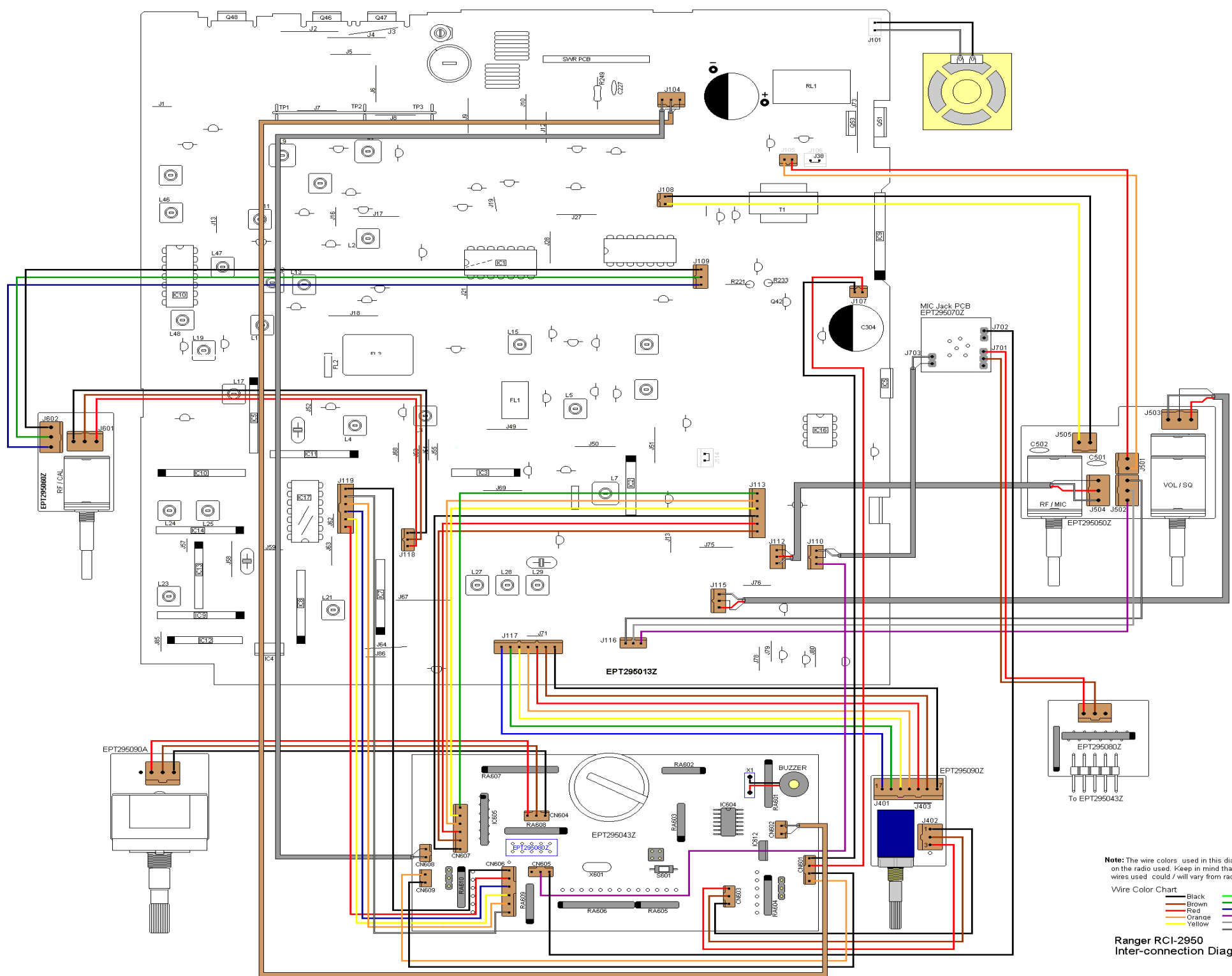

**Note:** The wire colors used in this diagram are based on the radio used. Keep in mind that the color of the wires used could / will vary from radio to radio.

Wire Color Chart

Black	Light Green
Brown	Green
Red	Blue
Orange	Violet
Yellow	Gray
	White

**Ranger RCI-2950  
Inter-connection Diagram**

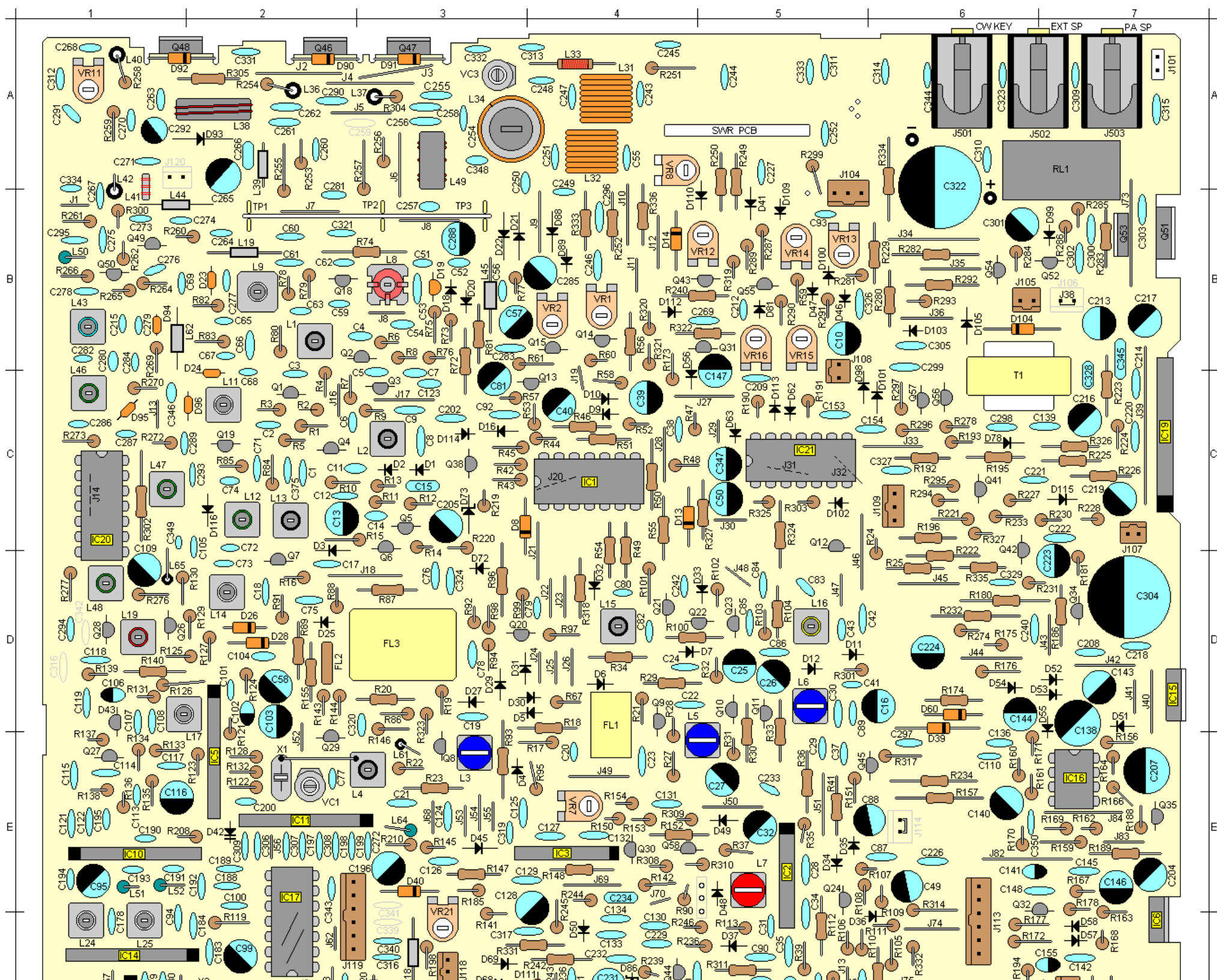

F

G

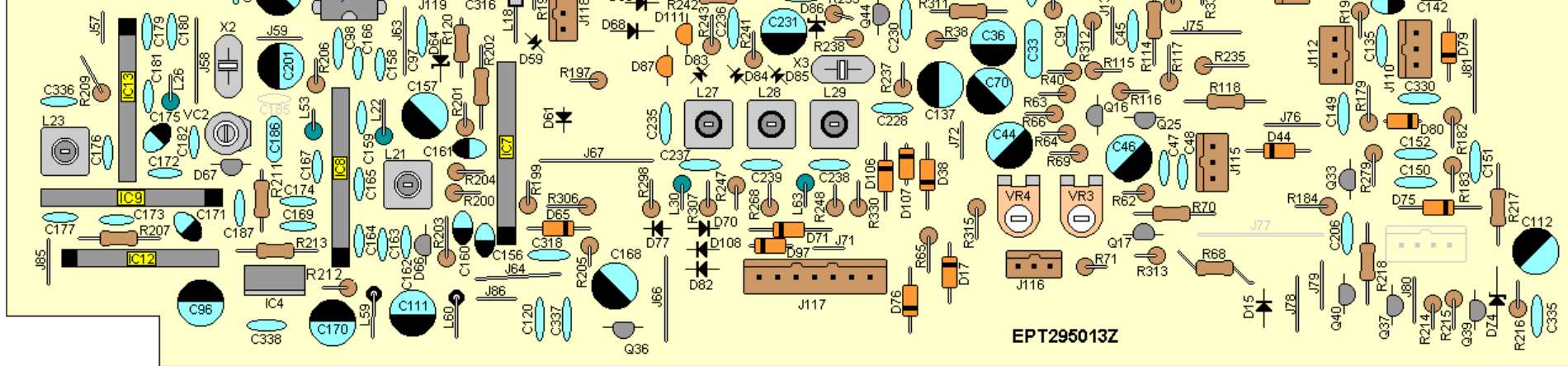

EPT295013Z

RANGER RCL-2950  
EPT295013Z

1 2 3 4 5 6 7

F

G

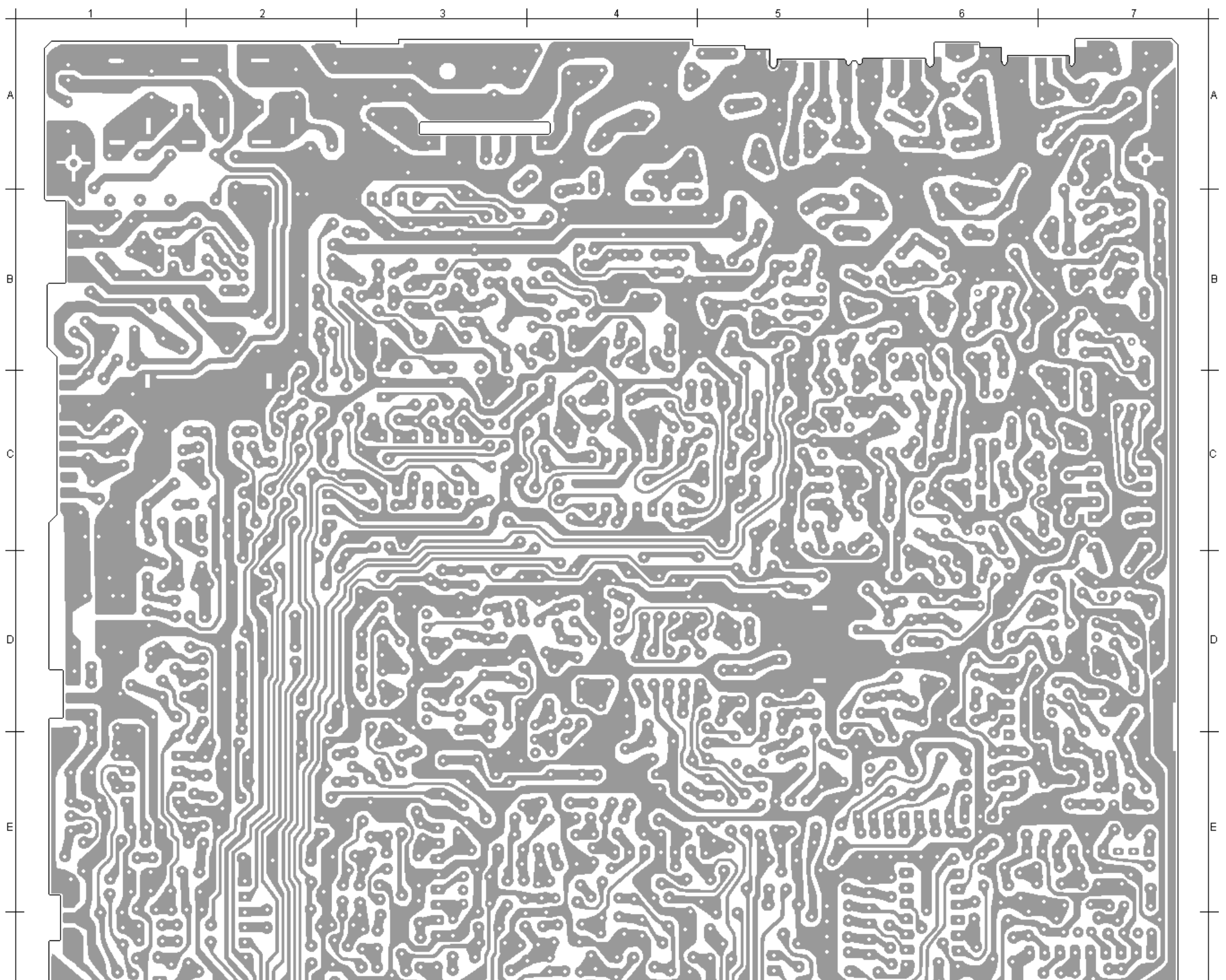

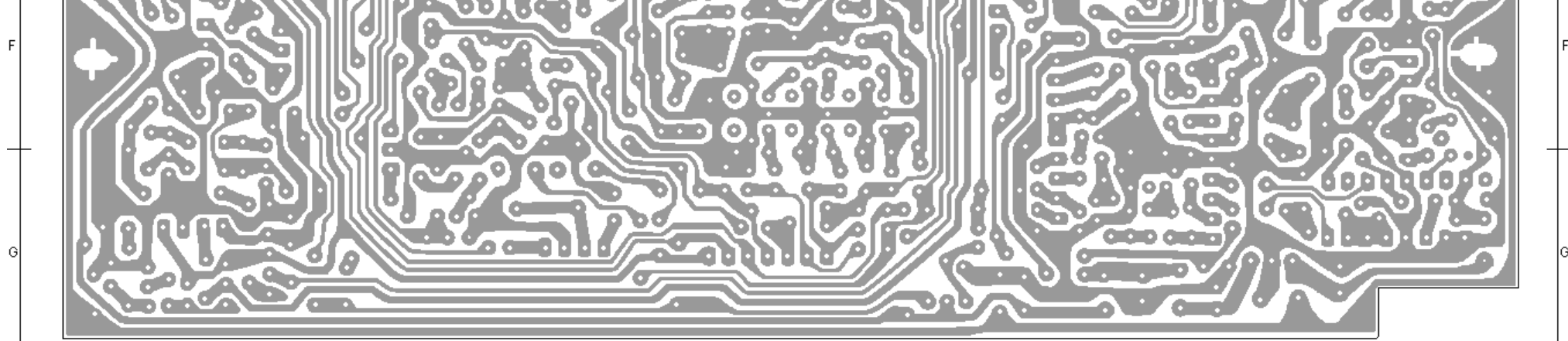

[www.radioaficion.com](http://www.radioaficion.com)

Ranger RCI2950 Main PCB  
EPT295013Z

**Ranger RCI 2950 LCD P.C. BOARD EPT2950217**

[Trace Layout](#)

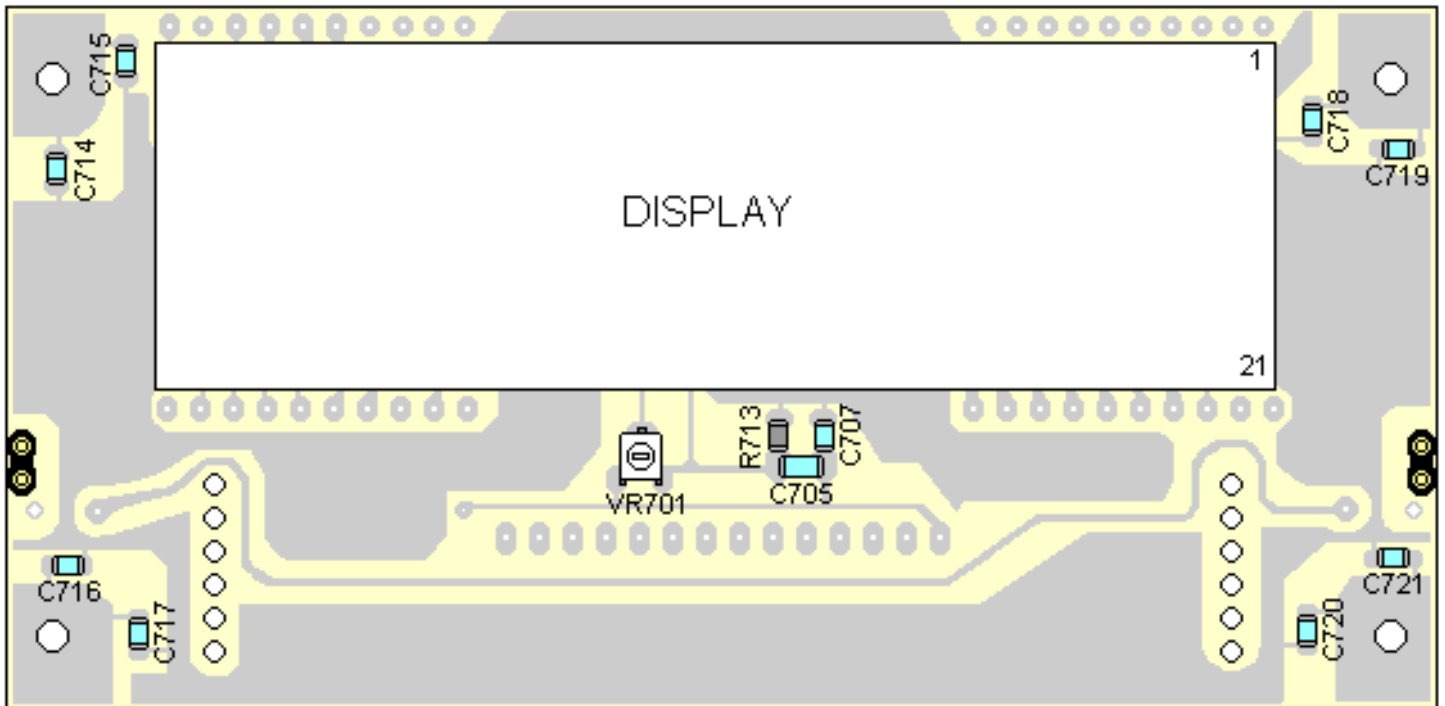

Top View

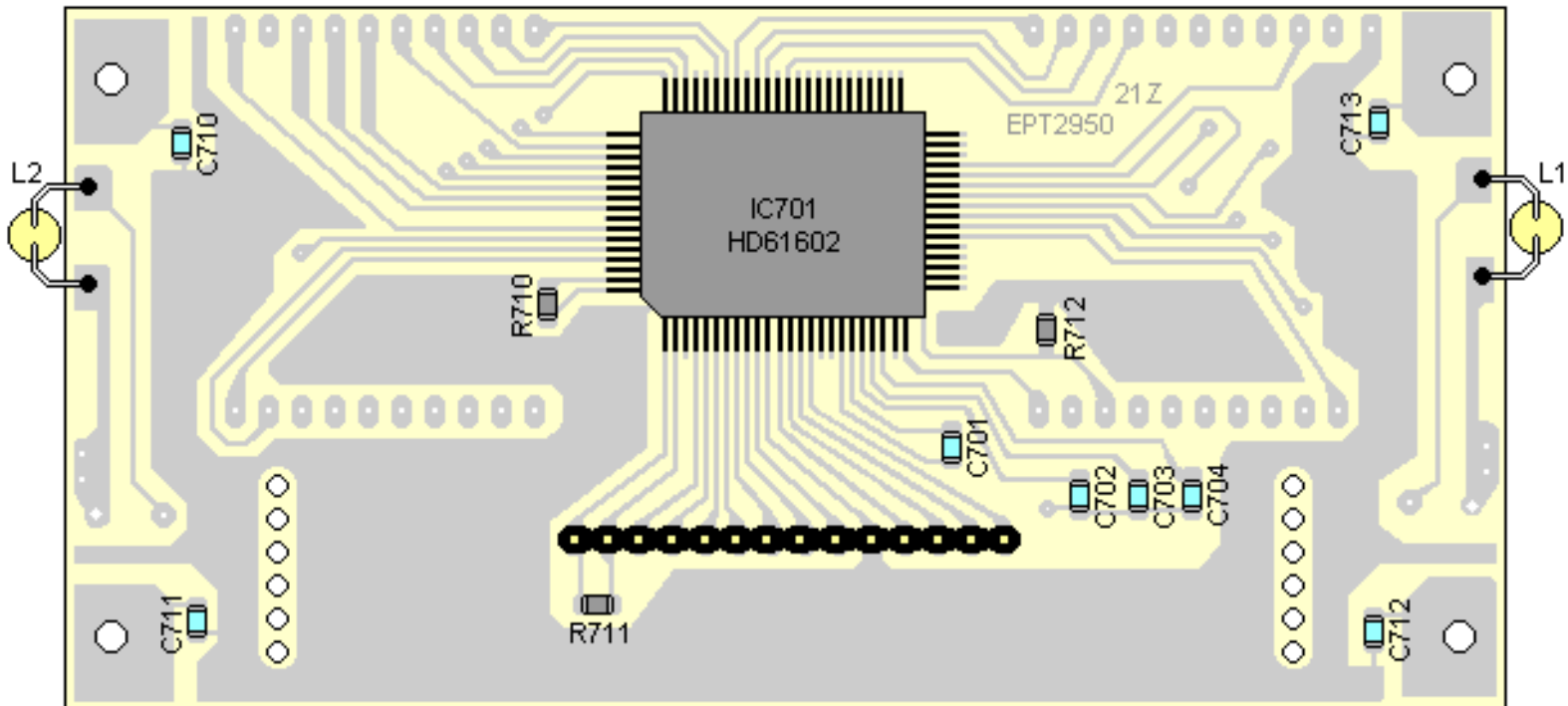

Bottom View

EPT295021Z LCD P.C.B.

**RESISTORS**

Ref#	Description	MFR. Part No.
R710	39K .1 W CHIP	ROY013934Z
R711	470K .1W, CHIP	ROY014744Z
R712	680 K .1 W	ROY016844Z

#### CAPACITORS

Ref#	Description	MFR. Part No.
C701	1uF 16WV M, TANTALUM	CTY161056Z
C702	.33uF 35WV M, TANTALUM	CTY353346Z
C703	.33uF 35WV M, TANTALUM	CTY353346Z
C704	.33uF 35WV M, TANTALUM	CTY353346Z
C705	1uF 16WV M, TANTALUM	CTY161056Z
C707	.01uF, 50WV, Z, Z5V, MONO.	CK1103AB7U
C710	.1uF, 25WV, Z, Y5V, MONO.	CK2104AB7V
C711	.1uF, 25WV, Z, Y5V, MONO.	CK2104AB7V
C712	.1uF, 25WV, Z, Y5V, MONO.	CK2104AB7V
C713	.1uF, 25WV, Z, Y5V, MONO.	CK2104AB7V
C714	.1uF, 25WV, Z, Y5V, MONO.	CK2104AB7V
C715	.1uF, 25WV, Z, Y5V, MONO.	CK2104AB7V
C716	.1uF, 25WV, Z, Y5V, MONO.	CK2104AB7V
C717	.1uF, 25WV, Z, Y5V, MONO.	CK2104AB7V
C718	.1uF, 25WV, Z, Y5V, MONO.	CK2104AB7V

<b>C719</b>	.1uF, 25WV, Z, Y5V, MONO.	CK2104AB7V
<b>C720</b>	.1uF, 25WV, Z, Y5V, MONO.	CK2104AB7V
<b>C721</b>	.1uF, 25WV, Z, Y5V, MONO.	CK2104AB7V

<b>Ref#</b>	<b>Description</b>	<b>MFR. Part No.</b>
<b>IC701</b>	IC HD61602R	ENH161602R

**Misc.**

<b>Ref#</b>	<b>Description</b>	<b>MFR. Part No.</b>
-	RESISTOR, 1 M SEM I-FIXED	RE10500102
-	LCD DISPLAY	EX03N40438
-	LAMP, 5V .08A	EX01 N40080
-	IS SOCKET 2P	EX07N48442
-	PCB CONN. SOCK. 14P L= 21.8mm	EX07N48438

LCD P.C. BOARD EPT2950217 Trace Layout

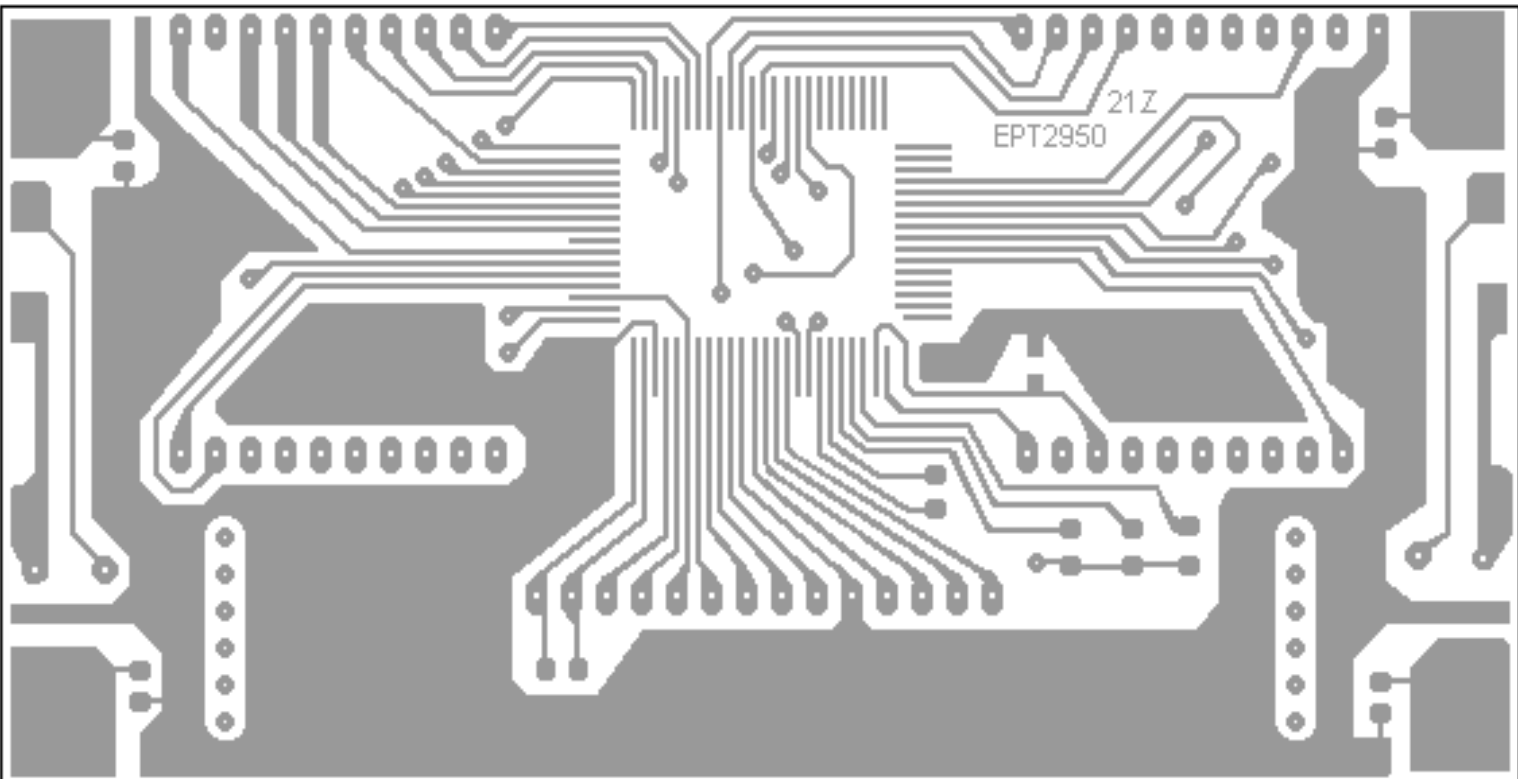
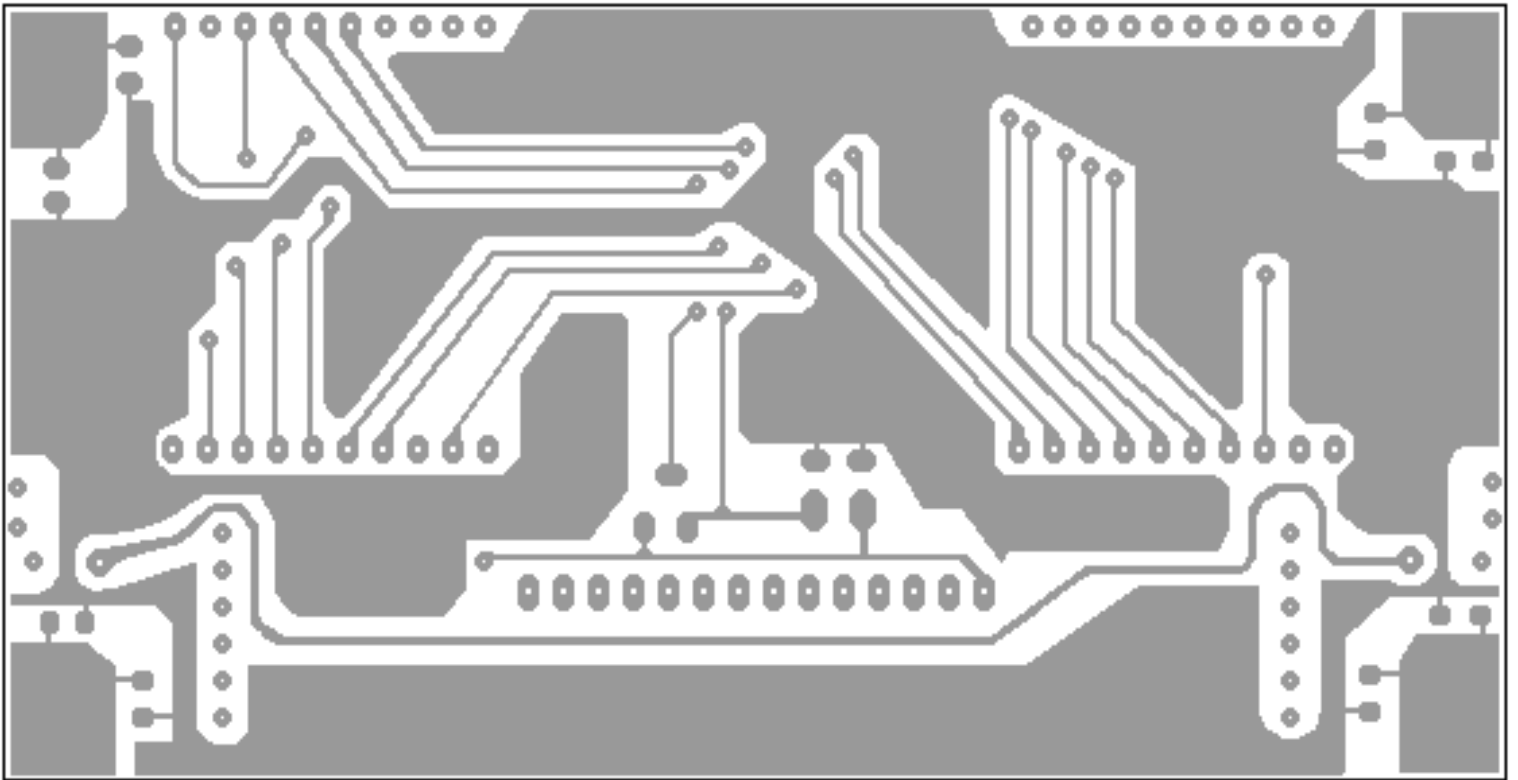

EPT295021Z LCD P.C.B.



Ranger RCI 2950 CPU PCB EPT295043Z

Trace Layout

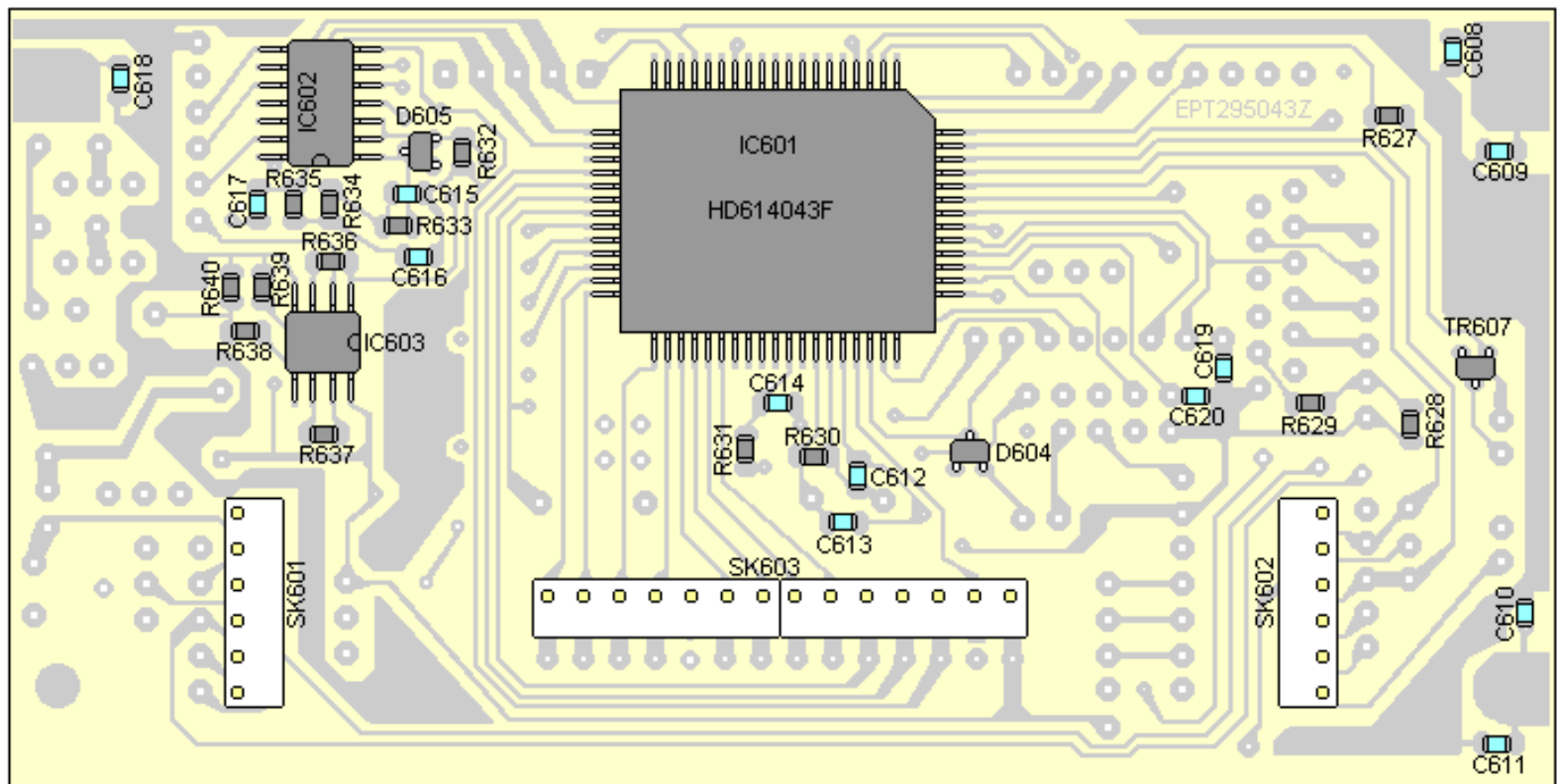
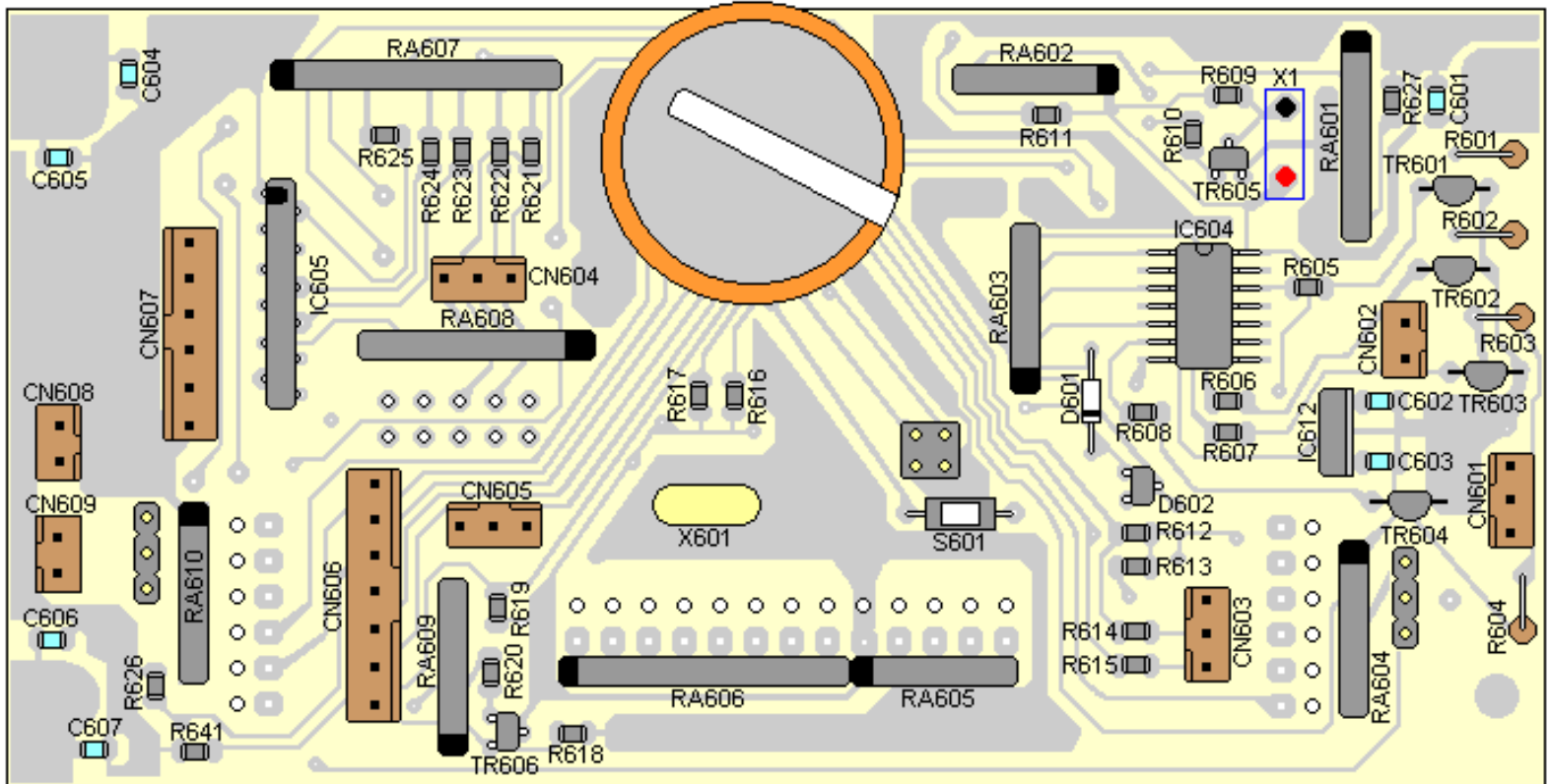

Ranger RCI-2950  
CPU PCB EPT295043Z

## RESISTORS

Ref#	Description	MFR. Part No.
R601	270ohm 1/4W (U) TYPE, CARBON	RCU142714Z
R602	220ohm 1/4W (U) TYPE, CARBON	RCU142214Z
R603	180ohm 1/4W (U) TYPE, CARBON	RCU141814Z
R604	82ohm 1/4W (U) TYPE, CARBON	RCU148204Z
R605	470ohm .1 W CHIP	RCY014714Z
R606	470ohm .1W CHIP	RCY014714Z
R607	470ohm .1W CHIP	RCY014714Z
R608	470ohm .1 W CHIP	RCY014714Z
R609	10ohm .1 W, CHIP	RCY011034Z
R610	1ohm .1 W CHIP	RCY011024Z
R611	47K, 0.1W CHIP	RCY014734Z
R612	47K, 0AW CHIP	RCY014734Z
R613	47K, 0.1W CHIP	RCY014734Z
R614	47K, 0.1 W CHIP	RCY014734Z
R615	47K, 0.1W CHIP	RCY014734Z
R617	47K, 0.1W CHIP	RCY014734Z
R618	47K, 0.1 W CHIP	RCY014734Z
R619	47K,.0.1W CHIP	RCY014734Z
R620	470ohm .1W CHIP	RCY014714Z
R621	47K 0.1W CHIP	RCY014734Z
R622	47K 0.1 W CHIP	RCY014734Z
R623	47K 0.1W CHIP	RCY014734Z
R624	47K 0.1 W CHIP	RCY014734Z

<b>R625</b>	47K 0.1W CHIP	RCY014734Z
<b>R626</b>	4.7K 0.1 W CHIP	RCY014724Z
<b>R627</b>	47K 0.1W CHIP	RCY014734Z
<b>R628</b>	47K 0.1 W CHIP	RCY014734Z
<b>R629</b>	47K 0.1W. CHIP	RCY014734Z
<b>R630</b>	RESISTOR, 1MEG, 0.1 W, CHIP	RCY011054Z
<b>R631</b>	10ohm .1 W CHIP	RCY011034Z
<b>R632</b>	47K 0.1 W CHIP	RCY014734Z
<b>R633</b>	39K 0.1 W CHIP	RCY013934Z
<b>R634</b>	RESISTOR, 220K 0.1 W CHIP	RCY012244Z
<b>R635</b>	RESISTOR, 1MEG 0.1W CHIP	RCY011054Z
<b>R636</b>	RESISTOR, 100K 0.1W CHIP	RCY011044Z
<b>R637</b>	RESISTOR, 220K 0.1W CHIP	RCY012244Z
<b>R638</b>	RESISTOR, 100K 0.1W CHIP	RCY011044Z
<b>R639</b>	RESISTOR, 47K 0.1W CHIP	RCY014734Z
<b>R640</b>	RESISTOR, 47K 0.1W CHIP	RCY014734Z
<b>R641</b>	RESISTOR, 47K 0.1W CHIP	RCY014734Z
<b>R642</b>	RESISTOR, 47K 0.1W CHIP	RCY014734Z
<b>R643</b>	RESISTOR, 47K 0.1W CHIP	RCY014734Z
<b>R644</b>	RESISTOR, 47K 0.1W CHIP	RCY014734Z
<b>R645</b>	RESISTOR, 47K 0.1W CHIP	RCY014734Z
<b>R646</b>	RESISTOR, 47K O.1W CHIP	RCY014734Z
<b>R647</b>	RESISTOR, 47K O.1W CHIP	RCY014734Z
<b>R648</b>	RESISTOR, 47K 0.1W CHIP	RCY014734Z
<b>R649</b>	RESISTOR, 47K 0.1W CHIP	RCY014734Z

<b>R650</b>	RESISTOR, 47K 0.1W CHIP	RCY014734Z
<b>R651</b>	RESISTOR, 47K 0.1W CHIP	RCY014734Z
<b>R652</b>	RESISTOR, 47 K 0.1W CHIP	RCY014734Z
<b>R653</b>	RESISTOR, 47 K 0.1W CHIP	RCY014734Z
<b>R654</b>	RESISTOR, 47 K 0.1W CHIP	RCY014734Z
<b>R655</b>	RESISTOR, 47 K 0.1W CHIP	RCY014734Z
<b>R656</b>	RESISTOR, 47 K 0.1W CHIP	RCY014734Z
<b>R657</b>	RESISTOR, 47 K 0.1W CHIP	RCY014734Z
<b>R658</b>	RESISTOR, 47 K 0.1W CHIP	RCY014734Z
<b>R659</b>	RESISTOR, 47 K 0.1W CHIP	RCY014734Z
<b>R660</b>	RESISTOR, 47 K 0.1W CHIP	RCY014734Z
<b>R661</b>	RESISTOR, 47 K 0.1W CHIP	RCY014734Z
<b>8662</b>	RESISTOR, 47 K 0.1W CHIP	RCY014734Z

**ARRAY RESISTORS**

<b>Ref#</b>	<b>Description</b>	<b>MFR. Part No.</b>
<b>RA601</b>	RESISTOR ARRAY, 10K/20K 6P	RCS0670023
<b>RA602</b>	RESISTOR ARRAY, 47K 5P	RCS0570009
<b>RA603</b>	RESISTOR ARRAY, 47K 5P	RCS0570009
<b>RA604</b>	RESISTOR ARRAY, 220K 5P	RCS0570022
<b>RA605</b>	RESISTOR ARRAY, 47K 5P	RCS0570009
<b>RA606</b>	RESISTOR ARRAY, 220K 9P	RCS0970021
<b>RA607</b>	RESISTOR ARRAY, 47K 9P	RCS0970015
<b>RA608</b>	RESISTOR ARRAY, 47K 7P	RCS0770020
<b>RA609</b>	RESISTOR ARRAY, 47K 5P	RCS0570009
<b>RA610</b>	RESISTOR ARRAY, 220K 5P	RCS0570022

<b>RA611</b>	RESISTOR ARRAY, 47K 5P	RCS0570009
--------------	------------------------	------------

**CAPACITORS**

<b>Ref#</b>	<b>Description</b>	<b>MFR. Part No.</b>
<b>C601</b>	.01uF 50WV K Z5U, MONO.	CK1103AB7U
<b>C602</b>	.1uF 35WV M, TANTALUM	CTY351046Z
<b>C603</b>	.33uF 35WV M, TANTALUM	CTY353346Z
<b>C604</b>	.01uF 50WV KZ5U, MONO.	CK1103A87U
<b>C605</b>	.01uF 50WV KZ5U, MONO.	CK1103AB7U
<b>C606</b>	.01uF 50WV K Z5U, MONO.	CK1103AB7U
<b>C607</b>	.01uF 50WV K Z5 U, MONO.	CK1103AB7U
<b>C608</b>	.01uF 50WV KZ5U, MONO.	CK1103AB7U
<b>C609</b>	.01uF 50WV K Z5 U, MONO.	CK1103AB7U
<b>C610</b>	.01uF 50WV K Z5U, MONO.	CK1103A87U
<b>C611</b>	.01uF 50WV K Z5 U, MONI0.	CK1103A87U
<b>C612</b>	33PF 50WV J CH, MONO CHIP	CK1330AB4A
<b>C613</b>	33PF 50WV J CH, MONO CHIP	CK1330AB4A
<b>C614</b>	.1uF 50WV Z Y5V, MONO.	CK2104AB7V
<b>C615</b>	.0027uF 50WV Z Y5V, MONO.	CK1272AB5R
<b>C616</b>	470PF 50WV K SL, MONO. CHIP	CK1471AB5L
<b>C617</b>	100PF 50WV K SL, MONO CHIP	CK1101AB5L
<b>C618</b>	.01uF 50WV K Z5U, MONO.	CK1103AB7U

**Integrated Circuits**

<b>Ref#</b>	<b>Description</b>	<b>MFR. Part No.</b>
<b>IC601</b>	IC HD4074008F	ENH174008F

<b>IC602</b>	IC TC4069UBF	ENTA04069F
<b>IC603</b>	IC M5223FP	ENMI05223F
<b>IC604</b>	IC TC4069UBF	ENTA04069F
<b>IC605</b>	IC TA78	TZTA00078Z
<b>IC606</b>	IC TA78	TZTA00078Z
<b>IC612</b>	IC 7805	ENSS07805Z

**TRANSISTORS**

<b>Ref#</b>	<b>Description</b>	<b>MFR. Part No.</b>
<b>TR601</b>	TRANSISTOR 2SC945P	T2SC00945P
<b>TR602</b>	TRANSISTOR 2SC945P	T2SC00945P
<b>TR603</b>	TRANSISTOR 2SC945P	T2SC00945P
<b>TR604</b>	TRANSISTOR 2SC945P	T2SC00945P
-	TRANSISTOR 2SA1162GR	T2SA01162G
<b>TR605</b>	TRANSISTOR 2SC2712	T2SC02712G
<b>TR606</b>	TRANSISTOR 2SC2712	T2SC02712G
<b>TR607</b>	TRANSISTOR 2SC2712	T2SC02712G

**DIODES**

<b>REF#</b>	<b>DESCRIPTION</b>	<b>PART#</b>
<b>D601</b>	DIODE 1N5711	ED1N05711Z
<b>D602</b>	DIODE 1SS181	EDSS00181Z
<b>D604</b>	DIODE 1SS181	EDSS00181Z
<b>D605</b>	DIODE 1SS181	EDSS00181Z

**Resonator**

<b>REF#</b>	<b>DESCRIPTION</b>	<b>PART#</b>

<b>X601</b>	RESONATOR, 4MHZ, CERAMIC	EX14N46510
-------------	--------------------------	------------

**Switch**

<b>REF#</b>	<b>DESCRIPTION</b>	<b>PART#</b>
<b>S601</b>	TACT SW	EWPS33042X

**Buzzer**

<b>REF#</b>	<b>DESCRIPTION</b>	<b>PART#</b>
-	BUZZER RKM35-4A	EX14N46511

**Battery**

<b>REF#</b>	<b>DESCRIPTION</b>	<b>PART#</b>
<b>L1</b>	BATTERY LITHIUM, 3V 170maH	EX08N41405

**Connectors**

<b>REF#</b>	<b>DESCRIPTION</b>	<b>PART#</b>
-	PCB CONNECTOR SOCKET 6P	EX07N41266
-	PCB CONNECTOR SOCKET 4P	EX07N41250
-	PCB CONNECTOR SOCKET 3P	EX07N41216
<b>CN602</b>	PCB CONNECTOR SOCKET 2P	EX07N41226
<b>CN608</b>	PCB CONNECTOR SOCKET 2P	EX07N41226
<b>CN609</b>	PCB CONNECTOR SOCKET 2P	EX07N41226
-	PCB CONNECTOR SOCKET 3P	EX07N48244
-	PCB CONNECTOR SOCKET 4P	EX07N48440
-	PCB CONNECTOR HOUSING 7P	EX07N48011
-	PCB CONNECTOR HOUSING 6P	EX07N48010
-	PCB CONNECTOR SOCKET 10P	EX07N48416

-	SHORT PIN 2P	EX07N48151
---	--------------	------------

[www.radioaficion.com](http://www.radioaficion.com)

CPU PCB EPT295043Z Trace Layout

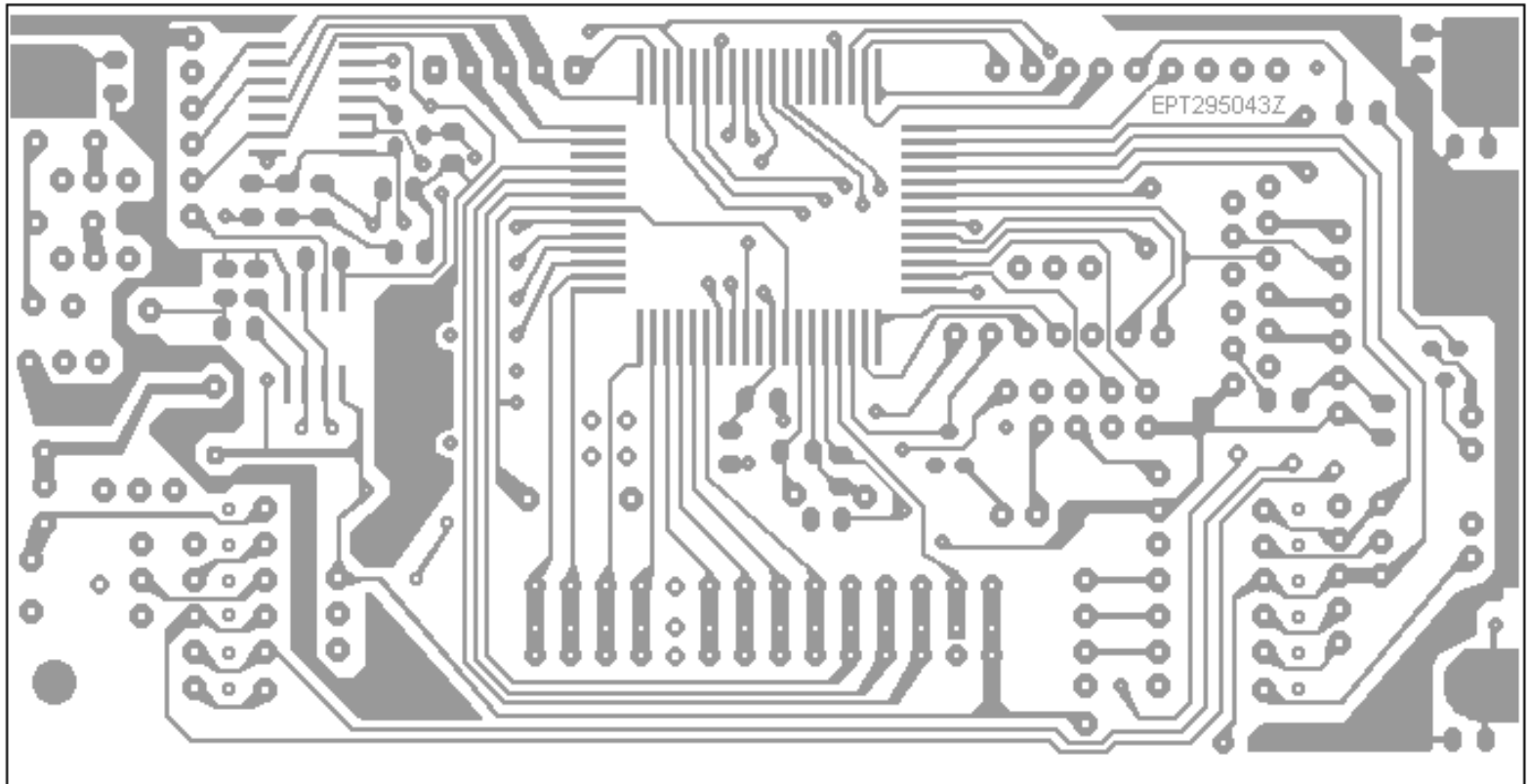
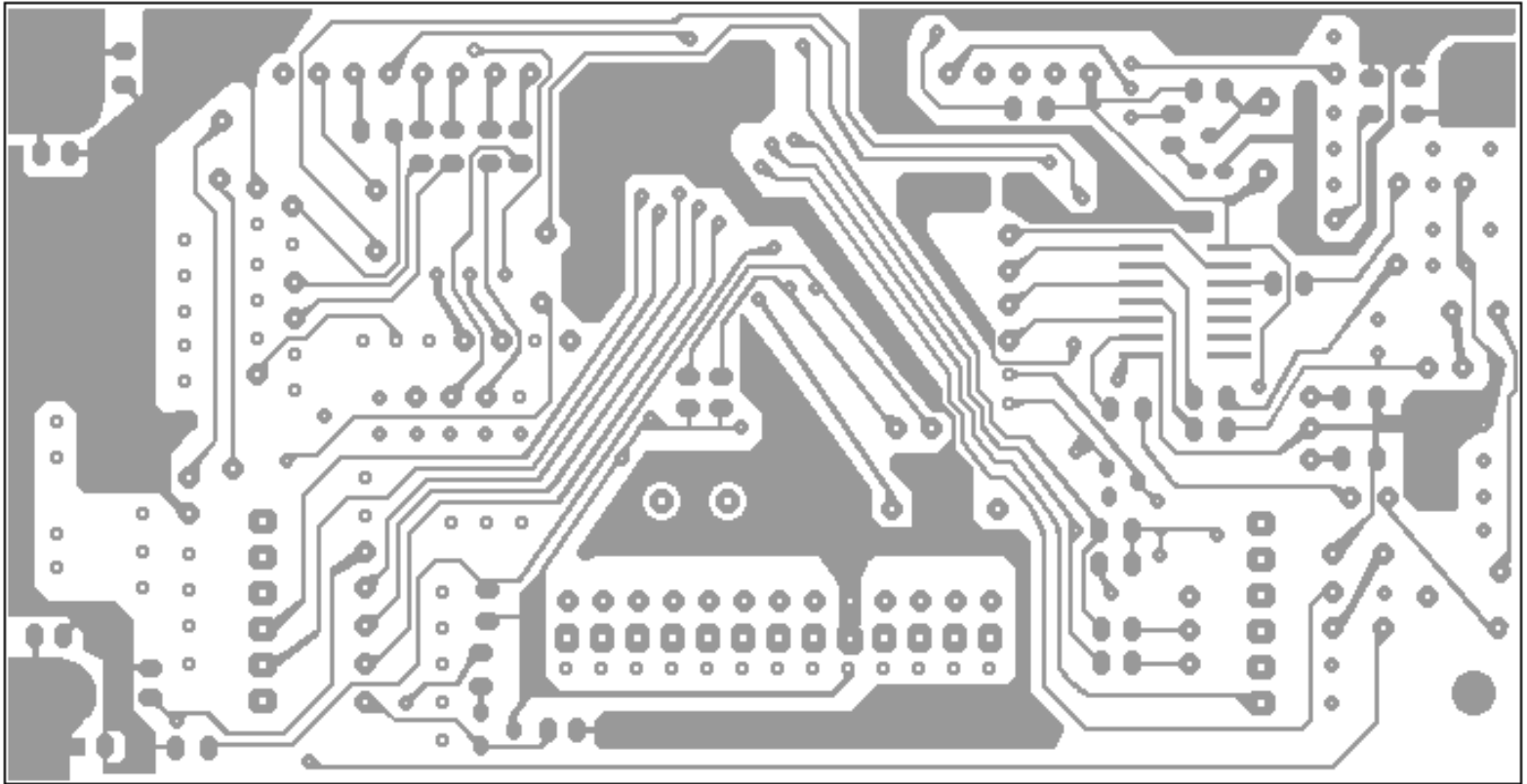

Ranger RCI-2950  
CPU PCB EPT295043Z

**Ranger RCI-2950** MIC UP/DW PCB (EPT295080Z)

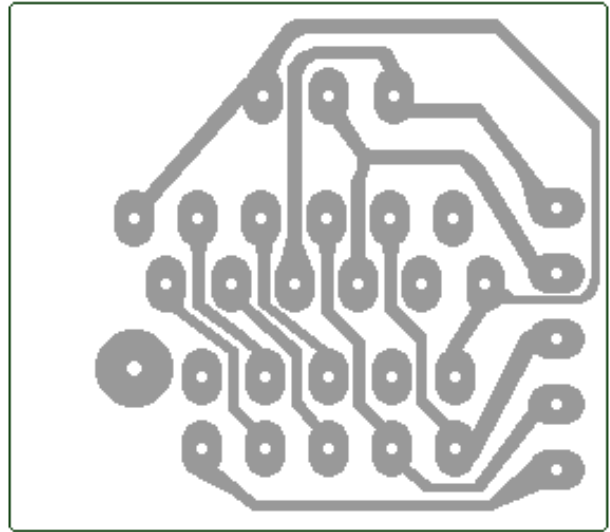
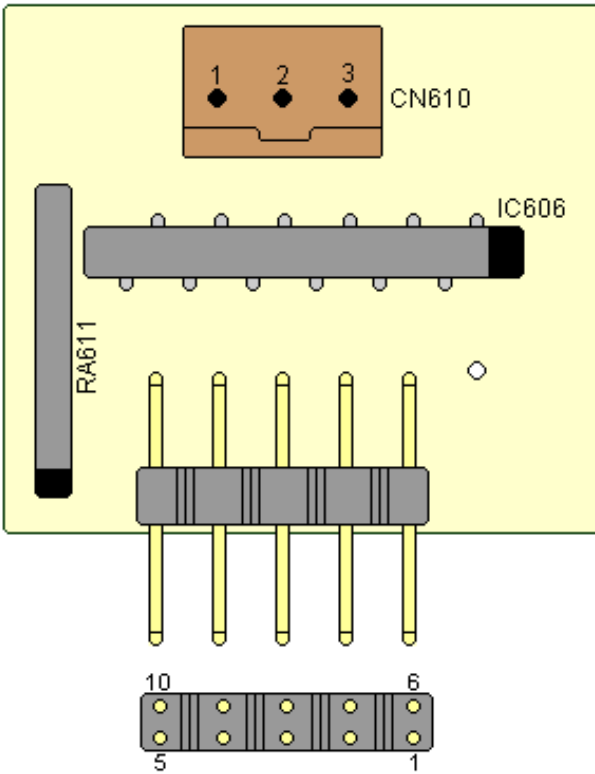

**RCI-2950**  
**MIC UP/DW EPT295080Z**

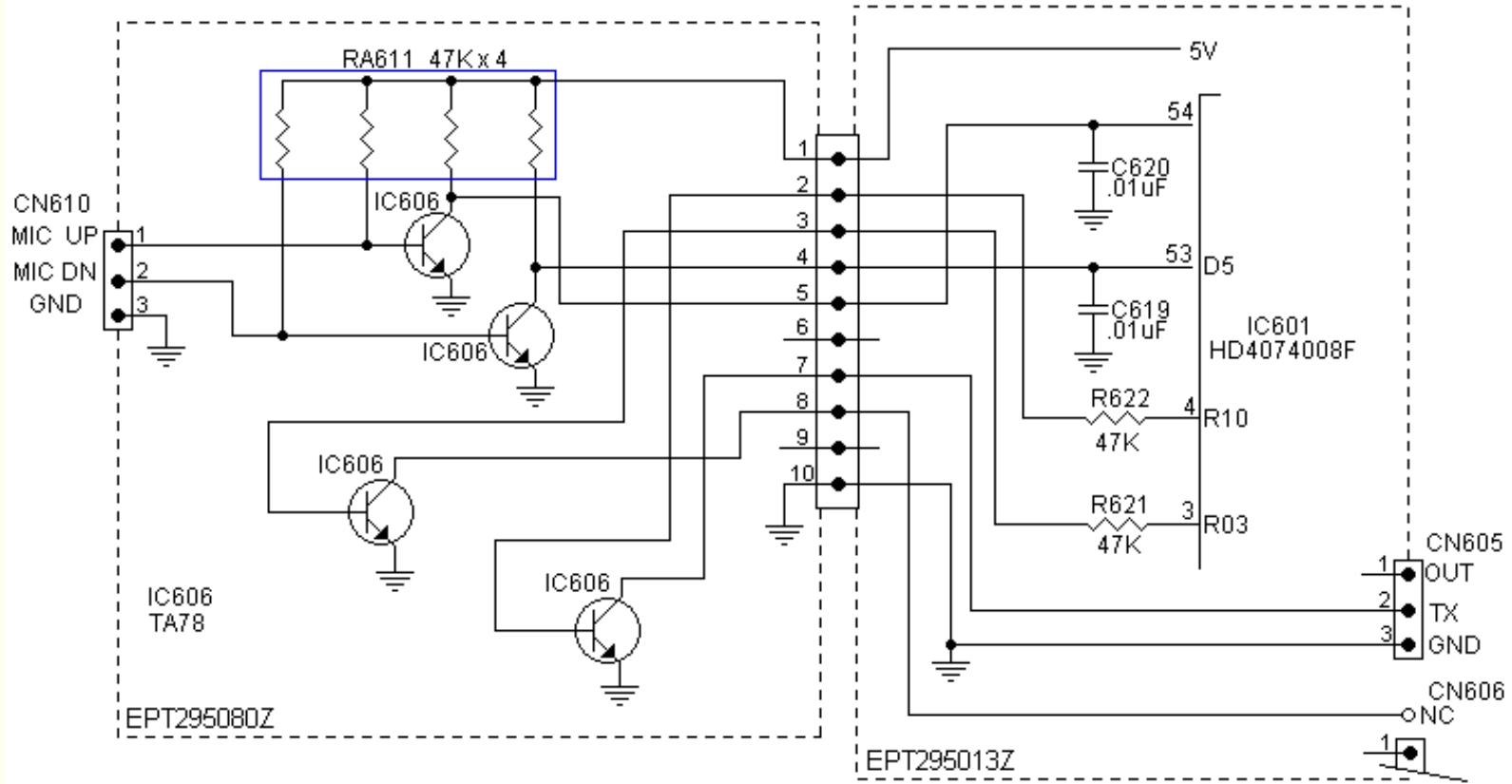

**Ranger RCI 2950 MIC JACK P.C. BOARD EPT295070Z**

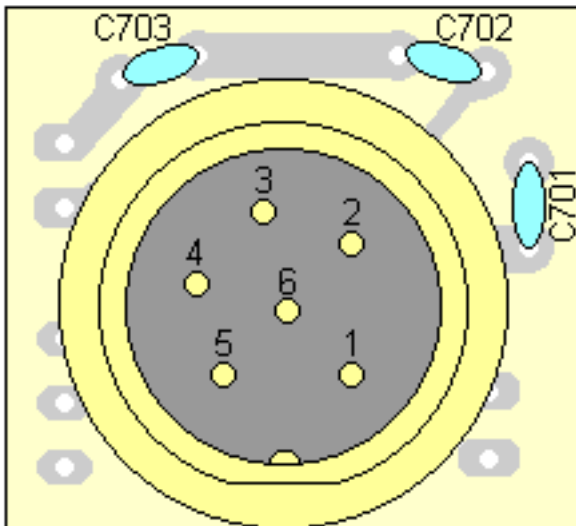

Top View

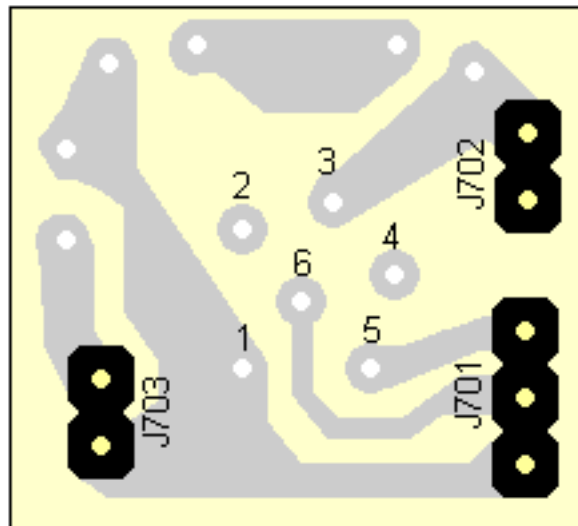

Bottom View

**RCI-2950  
MIC Jack PCB EPT295070Z**

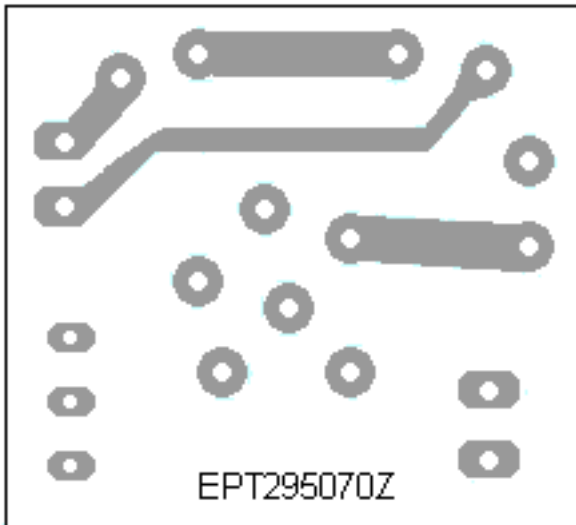

Top View

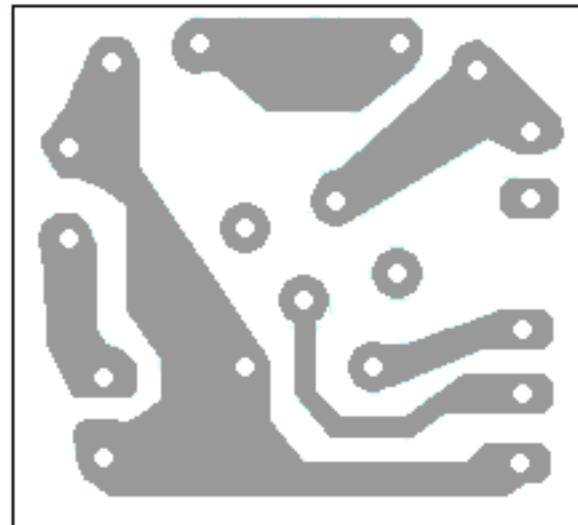

Bottom View

**RCI-2950  
MIC Jack PCB EPT295070Z**

**CERAMIC CAPACITORS**

Ref#	Description	MFR. Part No.

<b>C701</b>	.001uF 50WV Z SL, CERAMIC	CC0501027L
<b>C702</b>	.001uF 50WV Z SL, CERAMIC	CC0501027L
<b>C703</b>	.001uF 50WV Z SL, CERAMIC	CC0501027L

### CONNECTORS

<b>Ref#</b>	<b>Description</b>	<b>MFR. Part No.</b>
<b>J701</b>	PCB CONNECTOR SOCKET 3P	EX07N48244
<b>J702</b>	PCB CONNECTOR SOCKET 2P	EX07N48152
<b>J703</b>	PCB CONNECTOR SOCKET 2P	EX07N48152
	MIC JACK 6P	EX06N41111

# Ranger RCI-2950

VSWR PCB (EPT360040Z)

[Schematic Diagram](#)

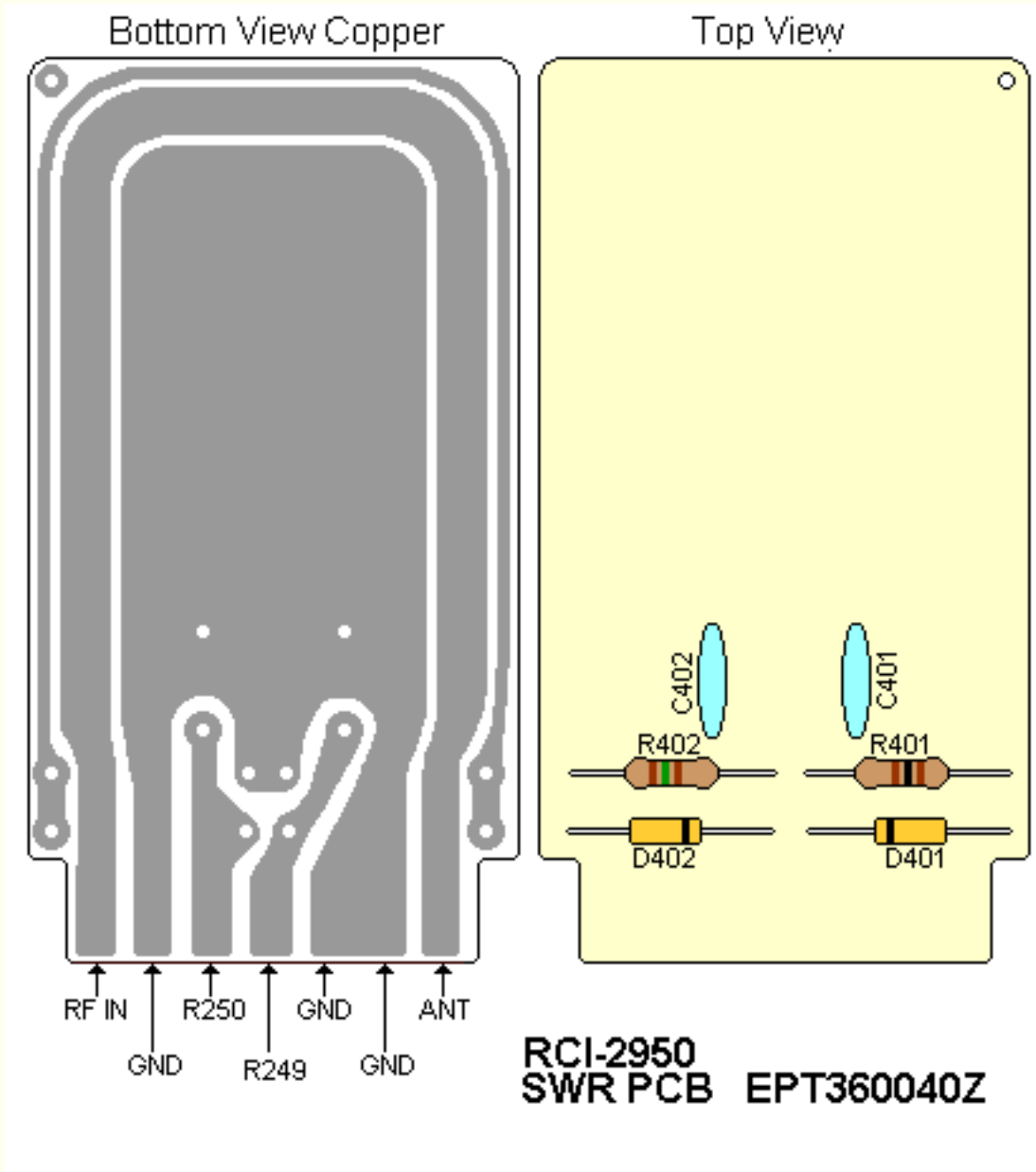

## Resistors

Ref#	Description	MFR. Part No.
R401	100ohm 1/4W (P) TYPE	RCP141014Z
R402	150 OHM 1/4W (P) TYPE	RCP141514Z

## Capacitors

<b>Ref#</b>	<b>Description</b>	<b>MFR. Part No.</b>
<b>C405</b>	.01uF 50WV Z SL, CERAMIC	CCO501037L
<b>C406</b>	.01uF 50WV Z SL, CERAMIC	CCO501037L

# Ranger RCI-2950

RCI-2950 VSWR P.C. BOARD EPT360040Z  
Schematic Diagram

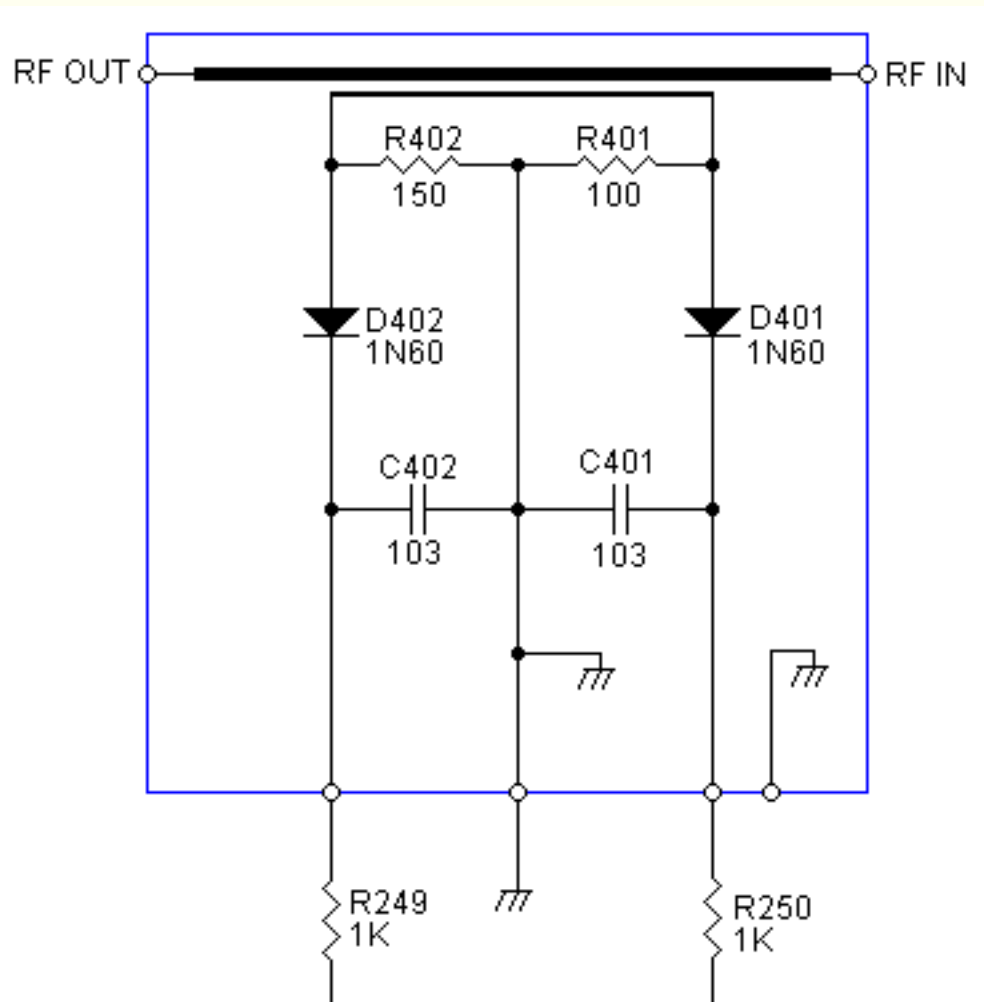

**RCI-2950  
SWR PCB EPT360040Z**

**Ranger RCI-2950** VR PCB RF/Mic Gain / Vol / SQ PCB (EPT295050Z)

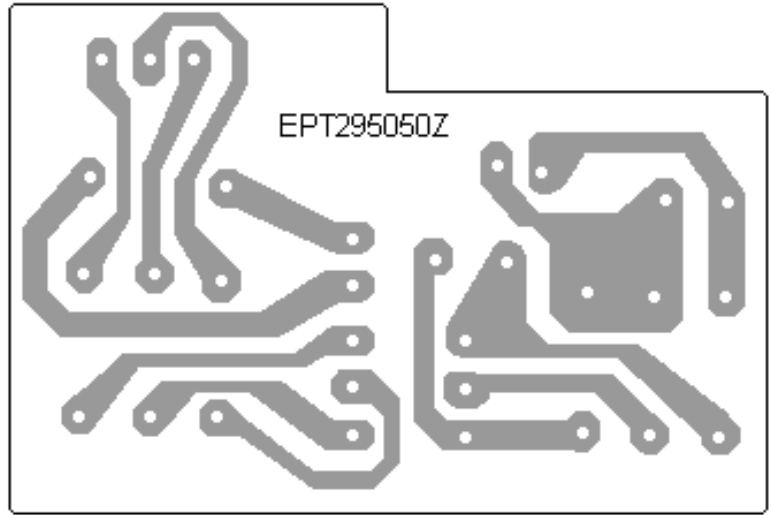
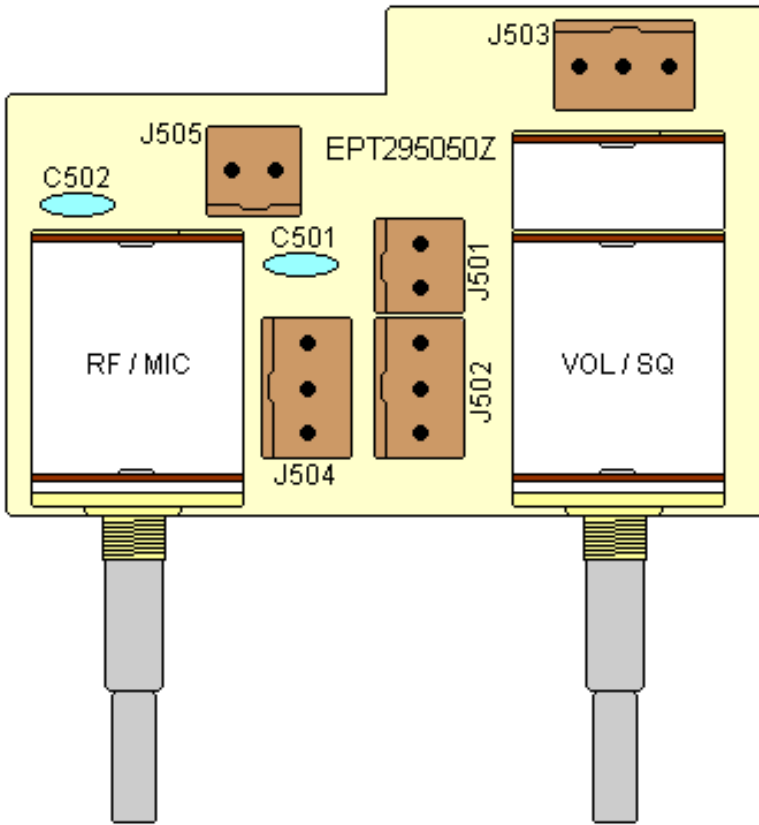

**RCI-2950  
VR PCB EPT295050Z**

**Capacitors**

Ref#	Description	MFR. Part No.
C501	.001uF 50WV Z SL, CERAMIC	CC0501027L
C505	.001uF 50WV Z SL, CERAMIC	CC0501027L

**Potentiometers**

Ref#	Description	MFR. Part No.
RF/MIC	VR 1KA-5KB	RV10203451
VOL/SQ	VR 50KB-50KA	RV50303453

**Connectors**

Ref#	Description	MFR. Part No.

<b>J501</b>	PCB CONNECTOR SOCKET 2P	EX07N41226
<b>J502</b>	PCB CONNECTOR SOCKET 2P	EX07N41226
<b>J503</b>	PCB CONNECTOR SOCKET 3P	EX07N41216
<b>J504</b>	PCB CONNECTOR SOCKET 3P	EX07N41216
<b>J505</b>	PCB CONNECTOR SOCKET 2P	EX07N41226

**Ranger RCI-2950** RCI-2950 VR (B) PCB (EPT295060Z)

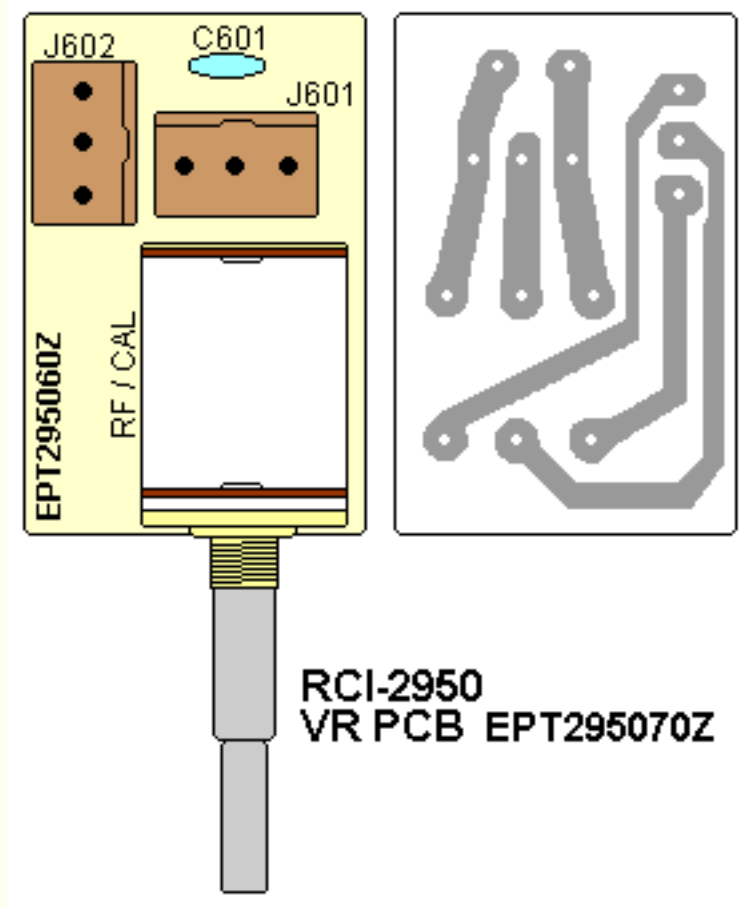

**Capacitors**

Ref#	Description	MFR. Part No.
C601	.001 OF 50VV Z SL, CERAMIC	CCO501027L

**Potentiometers**

Ref#	Description	MFR. Part No.
RF/CAL	VR 1KB-20KB	RV10203456

**Connectors**

Ref#	Description	MFR. Part No.

<b>J601</b>	PCB CONN. SOCKET 3P	EX07N41216
<b>J602</b>	PCB CONN. SOCKET 3P	EX07N41216

**Ranger RCI 2950** CH/SW P.C. BOARD EPT295090A

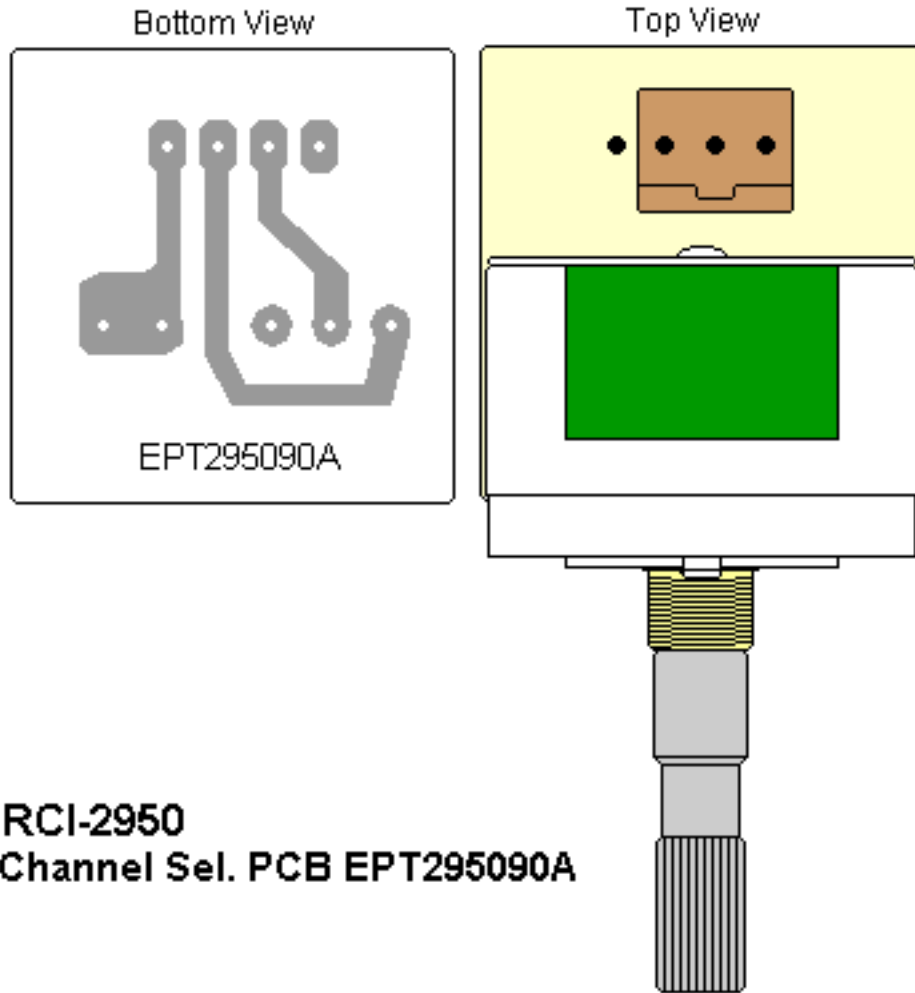

**RCI-2950**  
**Channel Sel. PCB EPT295090A**

Ref#	Description	MFR. Part No.
	ROTARY SW, GPS-688	EWRT32051S
	PCB CONN. SOCKET, 3P	EX07N41216

**Ranger RCI 2950** MODE P.C. BOARD EPT295090Z  
[Schematic Diagram](#)

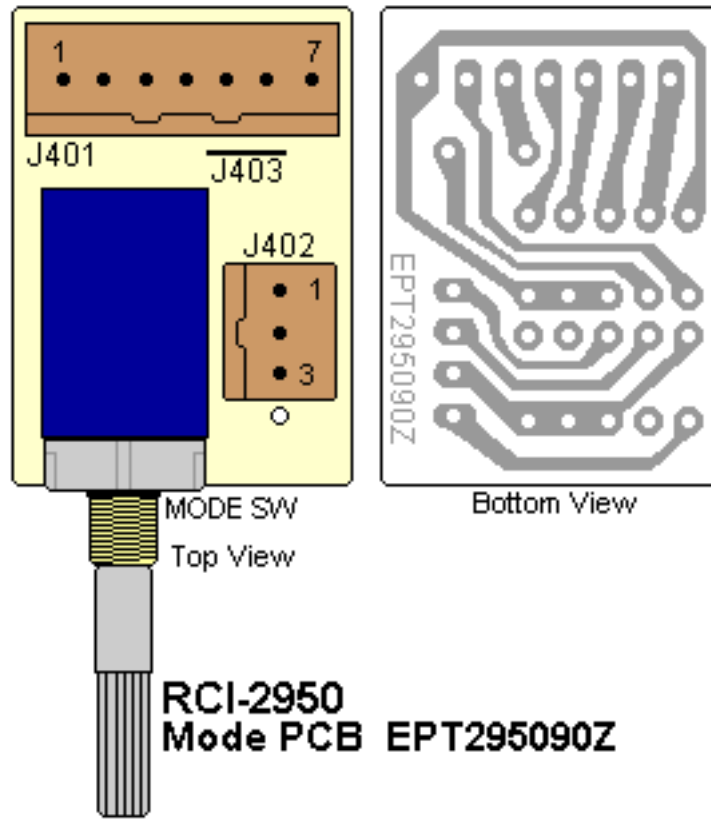

**RCI-2950  
 Mode PCB EPT295090Z**

Ref#	Description	MFR. Part No.
	ROTARY SW, 6N	EWRT32053S
	PCB CONN. SOCKET, 3P	EX07N41216
	PCB CONN. SOCKET, 7P	EX07N41261
<b>J403</b>	JUMPER WIRE 7x6x7mm	WX01070706

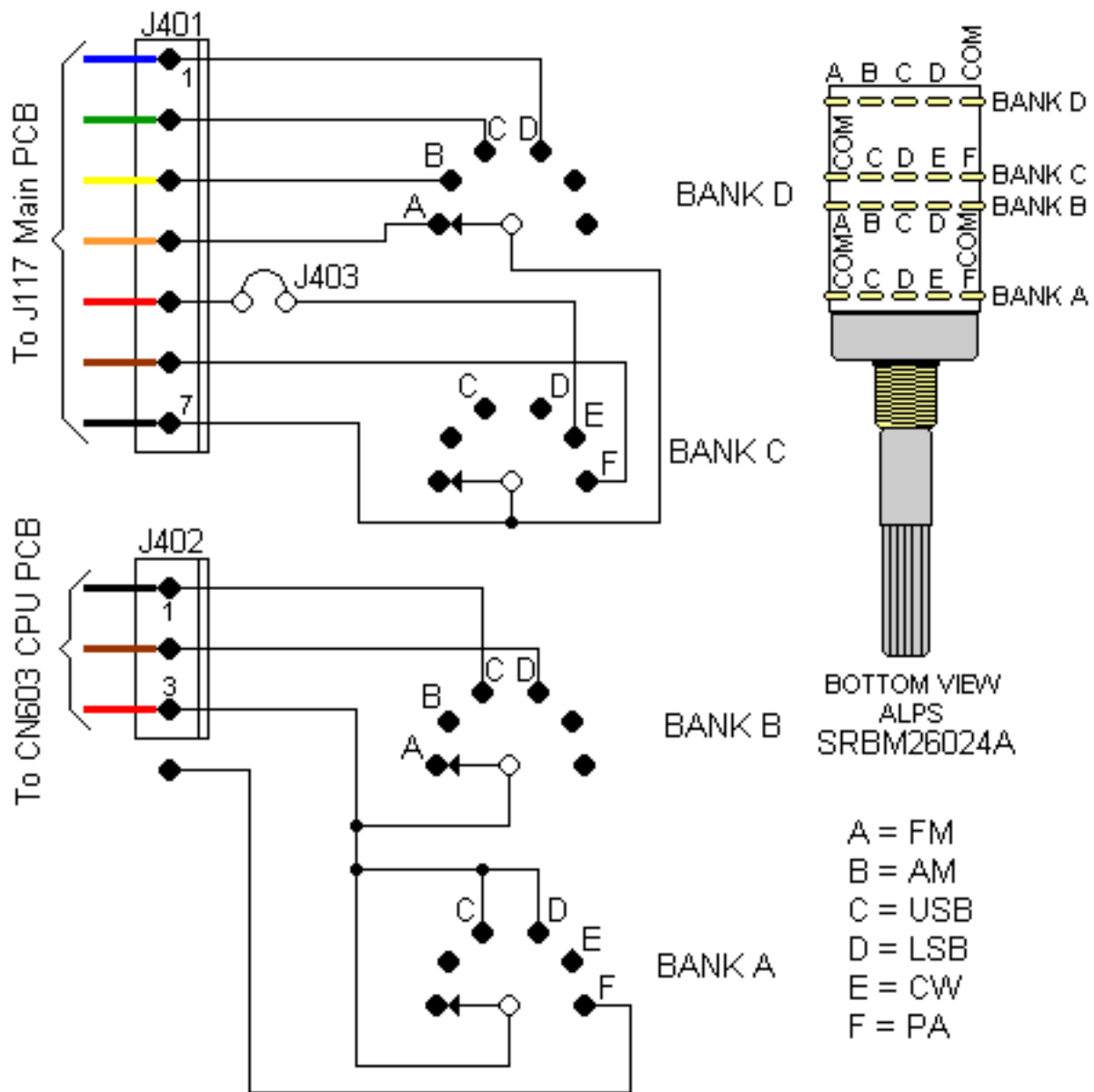

**Galaxy DX Radios DX2527  
Mode Switch PCB EPT295090Z**

EPT295031Z Push Switch PCB EPT295031Z

[Trace Layout](#)  
[Schematic Diagram](#)

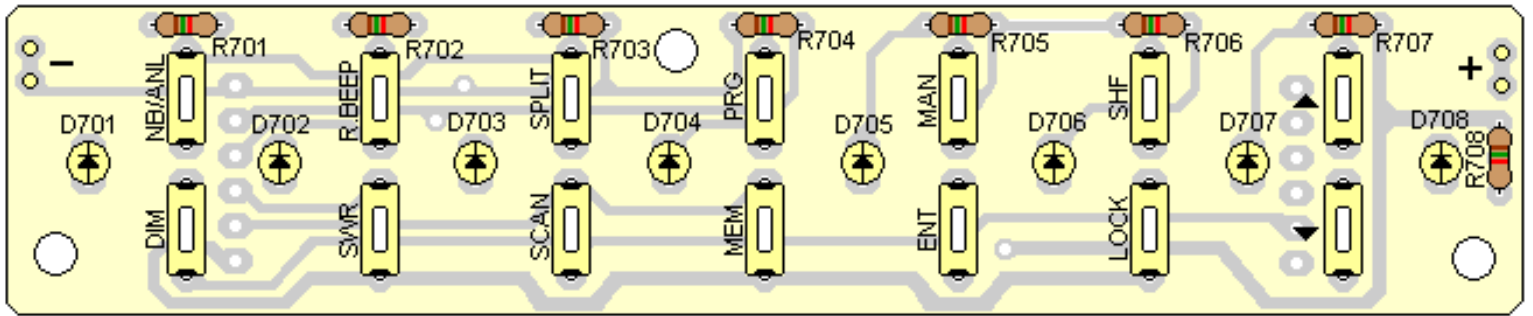

Top View

**RCI-2950**  
**Pushbutton Switch PCB EPT295031Z**

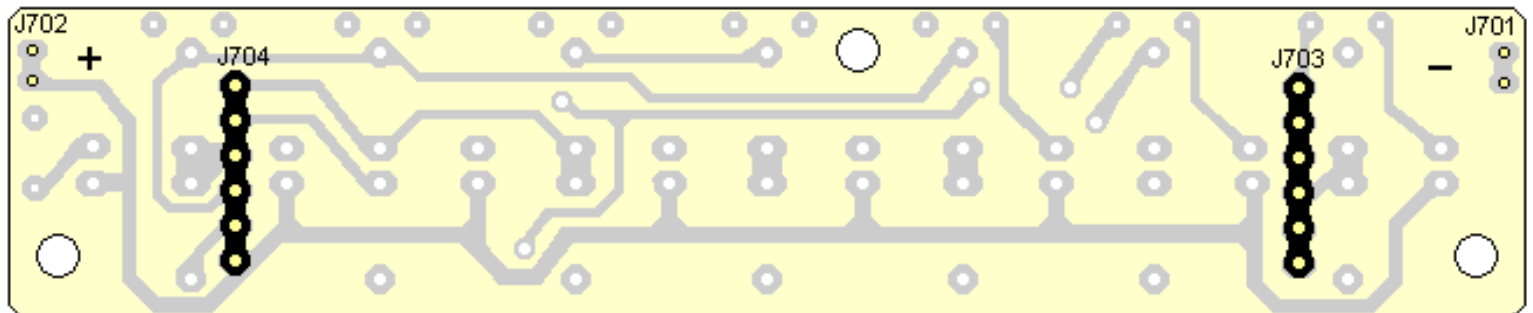

Bottom View

**RCI-2950**  
**Pushbutton Switch PCB EPT295031Z**

**CARBON FIXED RESISTORS**

Ref#	Description	MFR. Part No.
	1.5K 1/16W(P) TYPE	RCP161524Z

**Misc.**

Ref#	Description	MFR. Part No.
	TACT SW	EWPS33042X
	IC PIN	EX07N48414
	LED YELLOW	EX01N40081

	PCB CONN. SOCK. 6P L= 21.8mm	EX07N48441
--	------------------------------	------------

**Ranger RCI 2950** EPT295031Z Push Switch PCB EPT295031Z Trace Layout

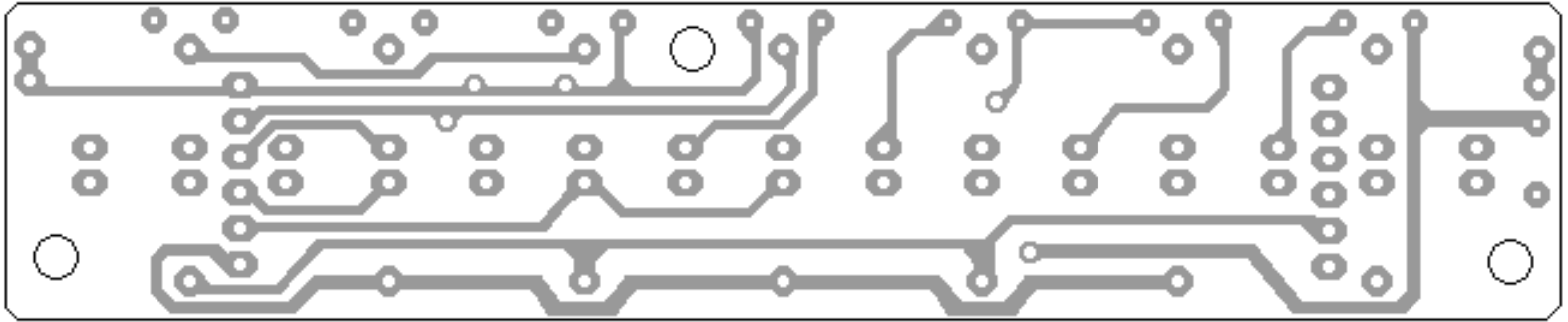

Top View

**RCI-2950**  
**Pushbutton Swith PCB EPT295031Z**

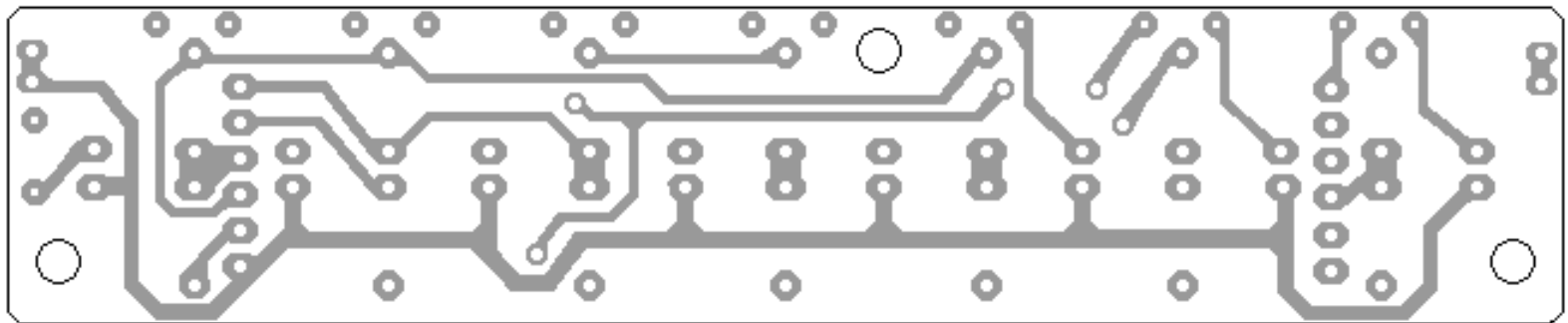

Bottom View

**RCI-2950**  
**Pushbutton Swith PCB EPT295031Z**

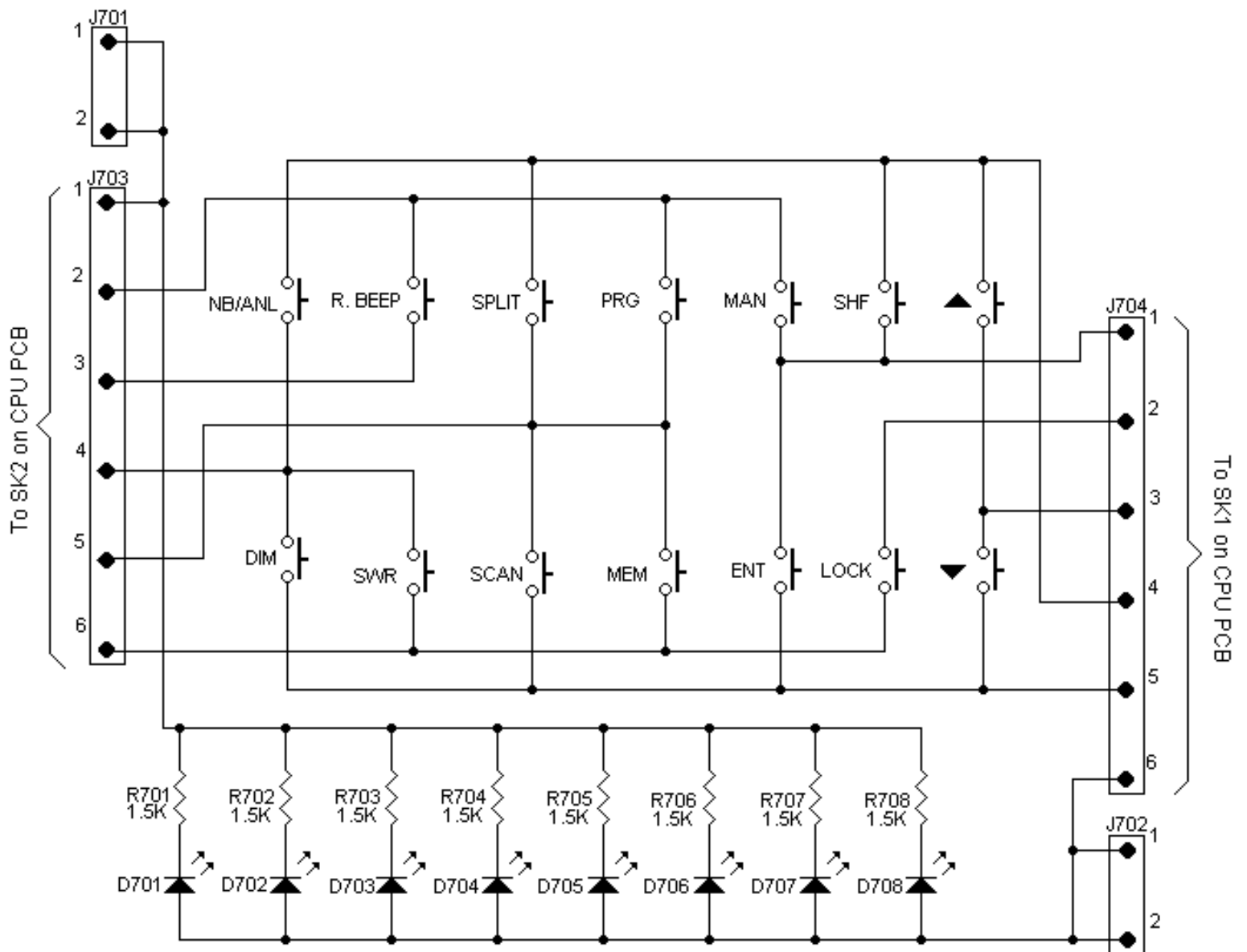

**RCI-2950**  
**Pushbutton Switch PCB EPT295031Z**

## RCI 2950 PARTS LISTS Capacitors

### Main PCB (EPT295013Z) Trimmer Capacitors

Ref#	Bd Loc	Description	MFR. Part No.
VC1		CAPACITOR, 20P, TRIMMER	CV050200AZ
VC2		CAPACITOR, 20P, TRIMMER	CV050200AZ
VC3		CAPACITOR, 30P, TRIMMER	CV050300AZ

### Capacitors

Ref#	Bd Loc	Description	MFR. Part No.
C1		5PF 50WV J CH, CERAMIC	CC0501004A
C2		.01uF 50WV Z SL, CERAMIC	CC0501037L
C3		.01uF 50WV Z SL, CERAMIC	CC0501037L
C4		100PF 50WV K SL, CERAMIC	CC0501015L
C5		5PF 50WV C CH, CERAMIC	CC0500501A
C6		.01uF 50WV Z SL, CERAMIC	CC0501037L
C7		.047uF 50WV Z SL, CERAMIC	CC0504737L
C8		.001uF 50WV Z SL, CERAMIC	CC0501027L
C9		.01uF 50WV Z SL, CERAMIC	CC0501037L
C10		4.7uF 16WV M, TANTALUM	CT0164756Z
C11		82PF 50WV J SL, CERAMIC	CC0508204L
C12		.01uF 50WV Z SL, CERAMIC	CC0501037L

<b>C13</b>		.47uF 50WV Z, ELECTROLYTIC	CE0504747Z
<b>C14</b>		330PF 50WV K SL, CERAMIC	CC0503315L
<b>C15</b>		.0022uF 50WV K, MYLAR	CM0502225Z
<b>C16</b>		2.2uF 50WV Z, ELECTROLYTIC	CE0502257Z
<b>C17</b>		330PF 50WV K SL, CERAMIC	CC0503315L
<b>C18</b>		.01uF 50WV Z SL, CERAMIC	CC0501037L
<b>C19</b>		.047uF 50WV Z SL, CERAMIC	CC0504737L
<b>C20</b>		5PF 50WV C SL. CERAMIC	CC0500501L
<b>C21</b>		.01uF 50WV Z SL, CERAMIC	CC0501037L
<b>C22</b>		.1UF 50WV Z SL, CERAMIC	CC0501047L
<b>C23</b>		.1uF 50WV Z SL, CERAMIC	CC0501047L
<b>C24</b>		.01uF50WV Z SL, CERAMIC	CC0501037L
<b>C25</b>		10uF 25WV Z, ELECTROLYTIC	CE0251067Z
<b>C27</b>		10uF 25WV Z, ELECTROLYTIC	CE0251067Z
<b>C28</b>		.047uF50WV Z SL, CERAMIC	CC0504737L
<b>C29</b>		68PF 50WV J SL, CERAMIC	CC0506804L
<b>C30</b>		560PF 50WV K SL, CERAMIC	CC0505615L
<b>C31</b>		15PF 50WV J CH, CERAMIC	CC0501504A
<b>C32</b>		47uF 10WV Z, ELECTROLYTIC	CE0104767Z
<b>C33</b>		.001uF 50WV K, MYLAR	CM0501025Z
<b>C34</b>		.01uF 50WV Z SL, CERAMIC	CC0501037L

<b>C35</b>		100PF 50WV K SL, CERAMIC	CC0501015L
<b>C36</b>		10uF 25WV Z, ELECTROLYTIC	CE0251067Z
<b>C37</b>		270PF 50WV K SL, CERAMIC	CC0502715L
<b>C38</b>		.01uF50WV Z SL, CERAMIC	CC0501037L
<b>C39</b>		47uF 10WV Z, ELECTROLYTIC	CE0104767Z
<b>C40</b>		47uF 10WV Z, ELECTROLYTIC	CE0104767Z
<b>C41</b>		.001uF 50WV Z SL, CERAMIC	CC0501027L
<b>C42</b>		.1uF 50WV Z SL, CERAMIC	CC0501047L
<b>C43</b>		10PF 50WV J SL, CERAMIC	CC0501004L
<b>C44</b>		47uF 10WV Z, ELECTROLYTIC	CE0104767Z
<b>C45</b>		.001uF 50WV Z SL, CERAMIC	CC0501027L
<b>C46</b>		47uF 10WV Z, ELECTROLYTIC	CE0104767Z
<b>C47</b>		.022uF 50WV K, MYLAR	CM0502235Z
<b>C48</b>		.1uF 50WV Z SL, CERAMIC	CC0501047L
<b>C49</b>		47uF 10WV Z, ELECTROLYTIC	CE0104767Z
<b>C50</b>		10uF 25WV Z, ELECTROLYTIC	CE0251067Z
<b>C51</b>		.001uF 50WV Z SL, CERAMIC	CC0501027L
<b>C52</b>		220PF 5CWV K SL, CERAMIC	CC0502215L
<b>C53</b>		12PF 50WV J CH, CERAMIC	CC0501204A
<b>C54</b>		.047UF 50WV Z SL, CERAMIC	CC0504727L
<b>C55</b>		68PF 50WV J CH, CERAMIC	CC0506804A

<b>C56</b>		.01uF 50WV Z SL, CERAMIC	CC0501037L
<b>C57</b>		10uF 25WV Z, ELECTROLYTIC	CE0251067Z
<b>C58</b>		1000uF 10WV Z, ELECTROLYTIC	CE0101087Z
<b>C59</b>		.047uF 50WV Z SL, CERAMIC	CC0504737L
<b>C60</b>		.01uF 50WV Z SL, CERAMIC	CC0501037L
<b>C61</b>		5PF 50WV J CH, CERAMIC	CC0501004A
<b>C63</b>		.1uF 50WV Z SL, CERAMIC	CC0501047L
<b>C65</b>		56PF 50WV J CH, CERAMIC	CC0503304A
<b>C66</b>		1 PF 50WV C CH, CERAMIC	CC0500101A
<b>C67</b>		39PF 50WV J CH, CERAMIC	CC0503904A
<b>C68</b>		5PF 50WV C CH, CERAMIC	CC0500501A
<b>C69</b>		.01uF 50WV Z SL, CERAMIC	CC0501037L
<b>C70</b>		10uF 25WV Z, ELECTROLYTIC	CE0251067Z
<b>C71</b>		.01uF 50WV Z SL, CERAMIC	CC0501037L
<b>C72</b>		3PF 50WV C CH, CERAMIC	CC0500301A
<b>C73</b>		3PF 50WV C CH, CERAMIC	CC0500301A
<b>C74</b>		.01uF50EV Z SL, CERAMIC	CC0501037L
<b>C75</b>		27PF 50WV J SL, CERAMIC	CC0502704L
<b>C76</b>		.1uF 50WV Z SL, CERAMIC	CC0501047L
<b>C77</b>		5PF 50WV C SL, CERAMIC	CC0500501L
<b>C78</b>		.01 UF50WV Z SL, CERAMIC	CC0501037L

<b>C79</b>		.01 UF50WV Z SL, CERAMIC	CC0501037L
<b>C80</b>		.047uF 50WV Z SL, CERAMIC	CC0504737L
<b>C81</b>		2.2uF 50WV Z, ELECTROLYTIC	CE0502257Z
<b>C82</b>		47PF 50WV J SL, CERAMIC	CC0504704L
<b>C83</b>		.01uF 50WV Z SL, CERAMIC	CC0501037L
<b>C84</b>		.1uF 50WV Z SL, CERAMIC	CC0501047L
<b>C85</b>		.1uF 50WV Z SL, CERAMIC	CC0501047L
<b>C86</b>		.1uF 50WV Z SL, CERAMIC	CC0501047L
<b>C87</b>		220PF 50WV K SL, CERAMIC	CC0502215L
<b>C88</b>		1uF 50WV Z, ELECTROLYTIC	CE0501057Z
<b>C89</b>		5PF 50WV C SL, CERAMIC	CC0500501 L
<b>C90</b>		5PF 50WV C CH, CERAMIC	CC0500501A
<b>C91</b>		15PF 50WV J SL, CERAMIC	CC0501504L
<b>C92</b>		1uF 50WV Z SL, CERAMIC	CC0501047L
<b>C93</b>		1uF 50WV Z SL, CERAMIC	CC0501047L
<b>C94</b>		.01uF 50WV Z SL, CERAMIC	CC0501037L
<b>C95</b>		22uF 10WV Z, ELECTROLYTIC	CE01022677
<b>C96</b>		220uF 16WV Z, ELECTROLYTIC	CE0162277~
<b>C97</b>		.01uF 50WV Z SL, CERAMIC	CC0501037L
<b>C98</b>		100PF 50WV K SL, CERAMIC	CC0501015L
<b>C99</b>		220uF 16WV Z, ELECTROLYTIC	CE0162277Z

<b>C100</b>	.01uF50WV Z SL, CERAMIC	CC0501037L
<b>C101</b>	.001uF 50WV Z SL, CERAMIC	CC0501027L
<b>C102</b>	1uF 16WV NP, ELECTROLYTIC	CE0161056N
<b>C103</b>	220uF 10WV Z, ELECTROLYTIC	CE0102277Z
<b>C104</b>	.047uF 50WV Z SL, CERAMIC	CC0504737L
<b>C105</b>	5PF 50WV J CH, CERAMIC	CC0501004A
<b>C106</b>	.22uF 16WV M, TANTALUM	CT0162246Z
<b>C107</b>	.001uF 50WV Z SL, CERAMIC	CC0501027L
<b>C108</b>	12PF 50WV J SL, CERAMIC	CC0501204L
<b>C109</b>	4.7uF 50WV Z, ELECTROLYTIC	CE0504757Z
<b>C110</b>	.01uF 50WV Z SL, CERAMIC	CC0501037L
<b>C111</b>	100uF 10WV Z, ELECTROLYTIC	CE0101077Z
<b>C112</b>	47uF 10WV Z, ELECTROLYTIC	CE0104767Z
<b>C113</b>	.01uF 50WV Z SL, CERAMIC	CC0501037L
<b>C114</b>	270PF 50WV K SL, CERAMIC	CC0502715L
<b>C115</b>	220PF 50WV K SL, CERAMIC	CC0502215L
<b>C116</b>	220uF 16WV Z, ELECTROLYTIC	CE0162277Z
<b>C117</b>	.047uF 50WV Z SL, CERAMIC	CC0504737L
<b>C118</b>	.01uF 50WV Z SL, CERAMIC	CC0501037L
<b>C119</b>	5PF 50WV J CH, CERAMIC	CC0501004A
<b>C120</b>	.01uF 50WV Z SL, CERAMIC	CC0501037L

<b>C121</b>		33PF 50WV J SL, CERAMIC	CC0503304L
<b>C122</b>		33PF 50WV J SL, CERAMIC	CC0503304L
<b>C123</b>		.01uF 50WV Z SL, CERAMIC	CC0501037L
<b>C124</b>		.01uF 50WV Z SL, CERAMIC	CC0501037L
<b>C125</b>		.001uF 50WV Z SL, CERAMIC	CC0501027L
<b>C126</b>		.01uF 50WV Z SL, CERAMIC	CC0501037L
<b>C127</b>		.01uF 50WV Z SL, CERAMIC	CC0501037L
<b>C128</b>		47uF 10WV Z, ELECTROLYTIC	CE0104767Z
<b>C129</b>		.01uF 50WV Z SL, CERAMIC	CC0501037L
<b>C130</b>		10PF 50WV J SL, CERAMIC	CC0501004L
<b>C131</b>		.1uF 50WV Z SL, CERAMIC	CC0501047L
<b>C132</b>		.01uF 50WV Z SL, CERAMIC	CC0501037L
<b>C133</b>		47PF 50WV J UJ, CERAMIC	CC0504704G
<b>C134</b>		100PF 50WV K UJ, CERAMIC	CC0501015G
<b>C135</b>		.001uF 50WV Z SL, CERAMIC	CC0501027L
<b>C136</b>		.1uF 50WV Z SL, CERAMIC	CC0501047L
<b>C137</b>		10uF 25WV Z, ELECTROLYTIC	CE0251067Z
<b>C138</b>		1000uF 10WV Z, ELECTROLYTIC	CE0101087Z
<b>C139</b>		.001uF 50WV Z SL, CERAMIC	CC0501027L
<b>C140</b>		2.2uF 50WV Z, ELECTROLYTIC	CE0502257Z
<b>C141</b>		.22uF 16WV M, TANTALUM	CT0162246Z

<b>C142</b>		.001uF 50WV Z SL, CERAMIC	CC0501027L
<b>C143</b>		47uF 10WV Z, ELECTROLYTIC	CE0104767Z
<b>C144</b>		1uF 50WV Z, ELECTROLYTIC	CE0501057Z
<b>C145</b>		.001uF 50WV Z SL, CERAMIC	CC0501027L
<b>C146</b>		2.2uF 50WV Z, ELECTROLYTIC	CE0502257Z
<b>C147</b>		10uF 25WV Z, ELECTROLYTIC	CE0251067Z
<b>C148</b>		.1uF 50WV Z SL, CERAMIC	CC0501047L
<b>C149</b>		.001uF 50WV Z SL, CERAMIC	CC0501027L
<b>C150</b>		.47uF 50WV Z SL, CERAMIC	CC0504727L
<b>C151</b>		.47uF 50WV Z SL, CERAMIC	CC0504727L
<b>C152</b>		.01uF50WV Z SL, CERAMIC	CC0501037L
<b>C153</b>		.001uF 50WV Z SL, CERAMIC	CC0501027L
<b>C154</b>		100PF 50WV K SL, CERAMIC	CC0501015L
<b>C155</b>		.22uF 16WV M, TANTALUM	CT0162246Z
<b>C156</b>		4.7uF 16WV M, TANTALUM	CT0164756Z
<b>C157</b>		220uF 16WV Z, ELECTROLYTIC	CE0162277Z
<b>C158</b>		150PF 50WV K SL, CERAMIC	CC0501515L
<b>C159</b>		.001uF 50WV Z SL, CERAMIC	CC0501027L
<b>C160</b>		.22uF 16WV M, TANTALUM	CT0162246Z
<b>C161</b>		2.2uF 16WV M, TANTALUM	CT0162256Z
<b>C162</b>		.001uF 50WV Z SL, CERAMIC	CC0501027L

<b>C163</b>		47PF 50WV J SL, CERAMIC	CC0504704L
<b>C164</b>		560PF 50WV K SL, CERAMIC	CC0505615L
<b>C165</b>		390PF 50WV K SL, CERAMIC	CC0503915L
<b>C166</b>		33PF 50WV J SL, CERAMIC	CC0503304L
<b>C167</b>		150PF 50WV K SL, CERAMIC	CC0501515L
<b>C168</b>		10uF 25WV Z, ELECTROLYTIC	CE0251067Z
<b>C169</b>		33PF 50WV J SL, CERAMIC	CC0503304L
<b>C170</b>		10uF 25WV Z, ELECTROLYTIC	CE0251067Z
<b>C171</b>		10uF 16WV M, TANTALUM	CT0161066Z
<b>C172</b>		33PF 50WV J SL, CERAMIC	CC0503304L
<b>C173</b>		47PF 50WV J CH, CERAWMIC	CC0504704A
<b>C174</b>		100PF 50VVV K SL, CERAMIC	CC0501015L
<b>C175</b>		10uF 16WV M, TANTALUM	CT0161066Z
<b>C176</b>		33PF 50WV J SL, CERAMIC	CC0503304L
<b>C177</b>		.01uF 50WV Z SL, CERAMIC	CC0501037L
<b>C178</b>		10PF 50WV J SL, CERAMIC	CC0501004L
<b>C179</b>		33PF 50WV J SL, CERAMIC	CC0503304L
<b>C180</b>		33PF 50WV J SL, CERAMIC	CC0503304L
<b>C181</b>		100PF 50WV K SL, CERAMIC	CC0501015L
<b>C182</b>		100PF 50WV K SL, CERAMIC	CC0501015L
<b>C183</b>		100PF 50WV K UJ, CERAMIC	CC0501015G

<b>C184</b>		82PF 50WV J UJ, CERAMIC	CC0508204G
<b>C186</b>		.001uF 50WV K, MYLAR	CM0501025Z
<b>C187</b>		.001uF 50WV Z SL, CERAMIC	CC0501027L
<b>C188</b>		100PF 50VVV K SL, CERAMIC	CC0501015L
<b>C189</b>		33PF 50WV J SL, CERAMIC	CC0503304L
<b>C190</b>		22PF 50WV J SL, CERAMIC	CC0502204L
<b>C191</b>		.001uF 50WV Z SL, CERAMIC	CC0501027L
<b>C192</b>		10PF 50WV J SL, CERAMIC	CC0501004L
<b>C193</b>		100PF 50WV K SL, CERAMIC	CC0501015L
<b>C194</b>		100PF 50WV K SL, CERAMIC	CC0501015L
<b>C195</b>		33PF 50WV J SL, CERAMIC	CC0503304L
<b>C196</b>		47uF 10WV Z, ELECTROLYTIC	CE0104767Z
<b>C197</b>		.01uF 50WV Z SL, CERAMIC	CC0501037L
<b>C198</b>		33PF 50WVG J SL, CERAMIC	CC0503304L
<b>C199</b>		22PF 50WV J SL, CERAMIC	CC0502204L
<b>C200</b>		.001uF 50WV Z SL, CERAMIC	CC0501027L
<b>C201</b>		47uF 10WV Z, ELECTROLYTIC	CE0104767Z
<b>C202</b>		.1uF 50WV Z SL, CERAMIC	CC0501047L
<b>C205</b>		10uF 25WV Z, ELECTROLYTIC	CE0251067Z
<b>C206</b>		.01uF 50WV Z SL, CERAMIC	CC0501037L
<b>C207</b>		220uF 16WV Z, ELECTROLYTIC	CE0162277Z

<b>C208</b>		.01uF 50WV Z SL, CERAMIC	CC0501037L
<b>C209</b>		.01uF 50WV Z SL, CERAMIC	CC0501037L
<b>C212</b>		.001uF 50WV Z SL, CERAMIC	CC0501027L
<b>C214</b>		.1uF 50WV Z SL, CERAMIC	CC0501047L
<b>C215</b>		27PF 50WV J CH, CERAMIC	CC0502704A
<b>C216</b>		22uF 10WV Z, ELECTROLYTIC	CE0102267Z
<b>C218</b>		.1uF 50WV Z SL, CERAMIC	CC0501047L
<b>C219</b>		4.7uF 50WV Z, ELECTROLYTIC	CE0504757Z
<b>C220</b>		.01uF 50WV Z SL, CERAMIC	CC0501037L
<b>C221</b>		.047uF 50WV Z SL, CERAMIC	CC0504727L
<b>C222</b>		.1uF 50WV Z SL, CERAMIC	CC0501047L
<b>C223</b>		47uF 10WV Z, ELECTROLYTIC	CE0104767Z
<b>C223</b>		.1uF 50WVZ SL, CERAMIC	CC0501047L
<b>C224</b>		1uF 50WV Z, ELECTROLYTIC	CE0501057Z
<b>C226</b>		.047uF 50WV Z SL, CERAMIC	CC0504727L
<b>C228</b>		.01uF 50WV Z SL, CERAMIC	CC0501037L
<b>C229</b>		150PF 60WV K SL, CERAMIC	CC0501515L
<b>C230</b>		270PF 50WV K SL, CERAMIC	CC0502715L
<b>C231</b>		100uF 10WV Z, ELECTROLYTIC	CE0101077Z
<b>C232</b>		.01uF 50WV Z SL, CERAMIC	CCO501037L
<b>C233</b>		.001uF 50WV Z SL, CERAMIC	CC0501027L

<b>C234</b>		.047uF 50WV M K, MYLAR	CM0504735Z
<b>C235</b>		.001uF 50WV K, MYLAR	CM0501025Z
<b>C236</b>		.001uF 50WV Z SL, CERAMIC	CC0501027L
<b>C237</b>		5PF 50WV C CH, CERAMIC	CC0500501A
<b>C238</b>		150PF 50WV K RH, CERAMIC	CC0501515D
<b>C239</b>		56PF 50WV J RH, CERAMIC	CC0505604D
<b>C240</b>		.1uF 50WV Z SL, CERAMIC	CC0501047L
<b>C242</b>		.01uF 50EV Z SL, CERAMIC	CC0501037L
<b>C243</b>		100PF 50WV K UJ, CERAMIC	CC0501015G
<b>C244</b>		.047uF 50WV Z SL, CERAMIC	CC0504737L
<b>C245</b>		.1uF 50WV Z SL, CERAMIC	CC0501047L
<b>C246</b>		120PF 50WV K CH, CERAMIC	CC0501215A
<b>C247</b>		180PF 50WV K UJ, CERAMIC	CC0501815G
<b>C248</b>		3PF 50WV C CH, CERAMIC	CC0500301A
<b>C249</b>		5PF 50WV C CH, CERAMIC	CC0500501A
<b>C250</b>		.5PF 50WV C SL, CERAMIC	CC0500591L
<b>C251</b>		270PF 50WV K CH, CERAMIC	CC0502715A
<b>C252</b>		3PF 50WV C CH, CERAMIC	CC0500301A
<b>C254</b>		330PF 50WV K UJ, CERAMIC	CC0503315G
<b>C255</b>		150PF 50WV K UJ, CERAMIC	CC0501515G
<b>C256</b>		.1uF 50WV Z SL, CERAMIC	CC0501047L

<b>C257</b>		.1uF 50WV Z SL, CERAMIC	CC0501047L
<b>C258</b>		560PF 50WV K UJ, CERAMIC	CC0505615G
<b>C259</b>		.01uF 50EV Z SL, CERAMIC	CC0501037L
<b>C260</b>		.01uF 50EV Z SL, CERAMIC	CC0501037L
<b>C261</b>		560PF 50WV K UJ, CERAMIC	CC0505615G
<b>C262</b>		560PF 50WV K UJ, CERAMIC	CC0505615G
<b>C263</b>		10PF 50WV J SL, CERAMIC	CC0501004L
<b>C264</b>		.1uF 50WV Z SL, CERAMIC	CC0501047L
<b>C265</b>		2.2uF 50WV Z, ELECTROLYTIC	CE0502257Z
<b>C266</b>		.22uF 50WV, CHIP	CH0502246Z
<b>C267</b>		.1uF 50WV Z SL, CERAMIC	CC0501047L
<b>C268</b>		.01uF 50EV Z SL, CERAMIC	CC0501037L
<b>C269</b>		100PF 50WV K UJ, CERAMIC	CC0501015G
<b>C270</b>		560PF 50WV K UJ, CERAMIC	CC0505615G
<b>C271</b>		.1uF 50WV Z SL, CERAMIC	CC0501047L
<b>C272</b>		100PF 50WV K SL, CERAMIC	CC0501015L
<b>C273</b>		.001uF 50WV Z SL, CERAMIC	CC0501027L
<b>C274</b>		.01uF 50WV Z SL, CERAMIC	CC0501037L
<b>C275</b>		270PF 50WV K UJ, CERAMIC	CC0502715G
<b>C276</b>		.047uFm50WV Z SL, CERAMIC	CC0504727L
<b>C277</b>		5PF 50WV J CH, CERAMIC	CC0501004A

<b>C278</b>		33PF 50WV J CH, CERAMIC	CC0503304A
<b>C279</b>		180PF 50WV K UJ, CERAMIC	CC0501815G
<b>C280</b>		12PF 50WV J CH, CERAMIC	CC0501204A
<b>C281</b>		.1uF 50WV Z SL, CERAMIC	CC0501047L
<b>C284</b>		100PF 50WV J CH, CERAMIC	CCO501015A
<b>C285</b>		1uF 50WV Z, ELECTROLYTIC	CE0501057Z
<b>C286</b>		.01uF 50WV Z SL, CERAMIC	CC0501037L
<b>C287</b>		.01uF50WV Z SL, CERAMIC	CC0501037L
<b>C288</b>		10uF 25WV Z, ELECTROLYTIC	CE0251067Z
<b>C289</b>		.001uF 50WV Z SL, CERAMIC	CC0501027L
<b>C290</b>		560PF 50WV K UJ, CERAMIC	CC0505615G
<b>C291</b>		.01uF 50WV Z SL. CERAMIC	CC0501037L
<b>C292</b>		10uF 25WVZ, ELECTROLYTIC	CE0251067Z
<b>C293</b>		12PF 50WV J CH, CERAMIC	CC0501204A
<b>C294</b>		.47uF 50WV Z SL, CERAMIC	CC0504737L
<b>C295</b>		.1uF 50WV Z SL, CERAMIC	CC0501047L
<b>C296</b>		.01uF 50WV Z SL, CERAMIC	CC0501037L
<b>C297</b>		.01uF 50WV Z SL, CERAMIC	CC0501037L
<b>C298</b>		.1uF 50WV Z SL, CERAMIC	CC0501047L
<b>C299</b>		.1uF 50WV Z SL, CERAMIC	CC0501047L
<b>C300</b>		.047uF 50WV Z SL, CERAMIC	CC0504737L

<b>C301</b>		100uF 10WV Z, ELECTROLYTIC	CE0101077Z
<b>C302</b>		.001uF 50WV Z SL, CERAMIC	CC0501027L
<b>C303</b>		.047uF 50WV Z SL, CERAMIC	CC0504737L
<b>C304</b>		2200uF 16WV Z, ELECTROLYTIC	CE0162287Z
<b>C305</b>		.01uF 50WV Z SL, CERAMIC	CC0501037L
<b>C306</b>		.001uF 50WV Z SL, CERAMIC	CC0501027L
<b>C307</b>		.01uF 50WV Z SL, CERAMIC	CC0501037L
<b>C308</b>		.01uF 50WV Z SL, CERAMIC	CC0501037L
<b>C309</b>		.001uF 50WV Z SL, CERAMIC	CC0501027L
<b>C310</b>		.1uF 50WV Z SL, CERAMIC	CC0501047L
<b>C311</b>		.01uF 50WV Z SL. CERAMIC	CC0501037L
<b>C312</b>		.047uF 50WV Z SL, CERAMIC	CC0504737L
<b>C313</b>		.1uF 50WV Z SL, CERAMIC	CC0501047L
<b>C314</b>		.1uF 50WV Z SL, CERAMIC	CC0501047L
<b>C316</b>		.001uF 50WV Z SL, CERAMIC	CC0501027L
<b>C317</b>		.047uF 50WV Z SL. CERAMIC	CC0504737L
<b>C319</b>		10PF 50WV J SL, CERAMIC	CC0501004L
<b>C320</b>		.01uF 50WV Z SL, CERAMIC	CC0501037L
<b>C321</b>		.01uF 50WV Z SL, CERAMIC	CC0501037L
<b>C322</b>		2200uF 16WV Z, ELECTROLYTIC	CE0162287Z
<b>C323</b>		.001 PF 50WV Z SL, CERAMIC	CC0501027L

<b>C324</b>		.1UF 50WV Z SL. CERAMIC	CC0501047L
<b>C325</b>		.01uF 50WV Z SL. CERAMIC	CC0501037L
<b>C326</b>		.1UF 50WV Z SL, CERAMIC	CC0501047L
<b>C327</b>		.01uF 50WV Z SL. CERAMIC	CC0501037L
<b>C328</b>		.22uF 50WV, CHIP	CH0502246Z
<b>C329</b>		.01uF 50WV Z SL, CERAMIC	CC0501037L
<b>C330</b>		.001uF 50WV Z SL, CERAMIC	CC0501027L
<b>C331</b>		.1UF 50WV Z SL, CERAMIC	CC0501047L
<b>C332</b>		.1uF 50WV Z SL, CERAMIC	CC0501047L
<b>C333</b>		.1uF 50WV Z SL, CERAMIC	CC0501047L
<b>C334</b>		.1uF 50WV Z SL, CERAMIC	CC0501047L
<b>C335</b>		.1uF 50WV Z SL, CERAMIC	CC0501047L
<b>C336</b>		.1uF 50WV Z SL, CERAMIC	CC0501047L
<b>C337</b>		.1uF 50WV Z SL, CERAMIC	CC0501047L
<b>C338</b>		.01uF 50WV Z SL, CERAMIC	CC0501037L
<b>C339</b>		100PF 50WV KSL, CERAMIC	CC0501015L
<b>C340</b>		.01uF 50WV Z SL, CERAMAIC	CC0501037L
<b>C341</b>		100PF 50WV K SL, CERAMIC	CC0501015L
<b>C343</b>		.001uF 50WV Z SL, CERAMIC	CC0501027L
<b>C345</b>		.22uF 50WV, CHIP	CH0502246Z
<b>C347</b>		1uF 50WV Z, ELECTROLYTIC	CE0501057Z

<b>C348</b>		3PF 50WV C CH, CERAMIC	CC050030 IA
<b>C349</b>		.01uF 50WV Z SL, CERAMIC	CC0501037L

[www.radioaficion.com](http://www.radioaficion.com)

## RCI 2950 PARTS LISTS Coils, Transformers, Crystals, Filters

### Main PCB (EPT295013Z)

#### Filters

Ref#	Bd Loc	Description	MFR. Part No.
FL1		FILTER, CFW455HT, CERAMIC	EFCFW455HT
FL2		FILTER, SEF 10.7 MX, CERAMIC	EFCFE107MX
FL3		FILTER, 10.695 MHZ, CRYSTAL	EFX8106952

#### Crystals

Ref#	Bd Loc	Description	MFR. Part No.
X1		10.240 MHZ, CRYSTAL	EYCAB10240
X2		10.240 MHZ, CRYSTAL	EYCAB10240
X3		10.6975 MHZ, CRYSTAL	EYCAE10697

#### Inductors

Ref#	Bd Loc	Description	MFR. Part No.
L1		IFT M199CC-P14097F	ECIFT12251
L2		IFT 199CC-PI498N	ECIFT12252
L3		IFT 7MC-7172ABN	ECIFT12002
L4		IFT M199CC-P14097F	ECIFT12251
L5		IFT 7MC-7172ABN	ECIFT12002
L6		IFT 7MC-7172ABN	ECIFT12002

<b>L7</b>		IFT 7MC-7174Y	ECIFT12003
<b>L8</b>		M199CNFP1499N	ECIFT12253
<b>L9</b>		IFT 199CN-P1549N	ECIFT12290
<b>L11</b>		IFT 199CN-P1549N	ECIFT12290
<b>L12</b>		IFT M199CC-P1501A	ECIFT12255
<b>L13</b>		IFT 199CC-PI 502N	ECIFT12256
<b>L14</b>		IFT 199CC-P1502N	ECIFT12256
<b>L15</b>		IFT 199CC-P1498N	ECIFT12252
<b>L16</b>		IFT M199CC-P1503A	ECIFT12257
<b>L17</b>		IFT 292CN-PI 121Z	ECIFT12263
<b>L18</b>		COIL, BEAD F PH= 12.5MM	ECBAD18550
<b>L19</b>		COIL, BEAD F PH= 12.5MM	ECBAD18550
<b>L19</b>		IFT M199CC-PI504N	ECIFT12258
<b>L21</b>		IFT 292CN-PI 121Z	ECIFF12263
<b>L22</b>		COIL, CHOKE 22 UH (P TYPE)	ECCHK16070
<b>L23</b>		IFT 199CC-P1498N	ECIFT12252
<b>L24</b>		IFT 199CC-P1498N	ECIFT12252
<b>L25</b>		IFT 199CC-PI498N	ECIFT12252
<b>L26</b>		COIL, CHOKE 470 UH (P TYPE)	ECCHK16096
<b>L27</b>		IFT 113CN-63442	ECIFT12016
<b>L28</b>		IFT 113CN-63442	ECIFT12016

<b>L29</b>		IFT 113CN-63442	ECIFT12016
<b>L30</b>		COIL, CHOKE 22 UH (P TYPE)	ECCHK16070
<b>L33</b>		COIL, CHOKE .82 UH	ECCHK16082
<b>L34</b>		COIL, RF .23UH	ECRFZ10001
<b>L36</b>		COIL, BEAD D SU-B-172D	ECBAD18504
<b>L37</b>		COIL, BEAD D SU-B-172D	ECBAD18504
<b>L38</b>		COIL, RF .23UH	ECRFZ10091
<b>L39</b>		COIL, BEAD F SU-B-172E	ECBAD18506
<b>L40</b>		COIL, BEAD D SU-B-172D	ECBAD18504
<b>L41</b>		COIL, TOROIDAL SUTR-398	ECRFZ10048
<b>L42</b>		COIL, BEAD F SU-B-172E	ECBAD18506
<b>L43</b>		IFT 292CN-PI 117AQ	ECIFT12262
<b>L44</b>		COIL, BEAD F PH= 12.5MM	ECBAD18550
<b>L45</b>		COIL, BEAD F PH= 12.5MM	ECBAD18550
<b>L46</b>		IFT 292CN-PI 125R	ECIFT12265
<b>L47</b>		IFT 292CN-PI 125R	ECIFT12265
<b>L48</b>		IFT M199CC-P1501A	ECIFT12255
<b>L49</b>		COIL. CHOKE (BIG ROUND)	ECCHK16151
<b>L50</b>		COIL, CHOKE .82 UH	ECCHK16082
<b>L51</b>		COIL, CHOKE 10 CHIP) TYPE	ECCHK16088
<b>L52</b>		COIL, CHOKE 10 CHIP) TYPE	ECCHK16088

<b>L53</b>		COIL, CHOKE 470 UH (P TYPE)	ECCHK16096
<b>L59</b>		COIL, BEAD F SU-B-172E	ECBAD18506
<b>L60</b>		COIL, BEAD F SU-B-172E	ECBAD18506
<b>L61</b>		COIL, BEAD F SU-B-172E	ECBAD18506
<b>L62</b>		COIL, BEAD E PH= 10MM	ECBAD18526
<b>L63</b>		COIL, CHOKE 470 UH (P TYPE)	ECCHK16096
<b>L65</b>		COIL, BEAD F SU-B-172E	ECBAD18506
<b>L131</b>		COIL, SPRING .8x6x8.5t	ECSPG18075
<b>L132</b>		COIL, SPRING .8x6.5x7.5t	ECSPR18003
<b>L503</b>		COIL, CHOKE.47 UH (P TYPE)	ECCHK16000
<b>L504</b>		COIL, CHOKE.47 UH (P TYPE)	ECCHK16000
<b>J52</b>		COIL, CHOKE 470 UH (P TYPE)	ECCHK16096
<b>T1</b>		COIL, CHOKE EI-19 TF-083	ECCHK16004

## RCI 2950 PARTS LISTS Resistors

### Main PCB (EPT295013Z) Variable Resistors

Ref#	Bd Loc	Description	MFR. Part No.
VR1		10K 3P, SEMI FIXED	RE10300078
VR2		10K 3P, SEMI FIXED	RE10300078
VR3		500K 3P, SEMI FIXED	RE50400080
VR4		500K 3P, SEMI FIXED	RE50400080
VR7		10K 3P, SEMI FIXED	RE10300078
VR8		100K 3P, SEMI FIXED	RE10400079
VR11		3K 3P, SEMI FIXED	RE30200076
VR12		10K 3P, SEMI FIXED	RE10300078
VR13		5K 3P, SEMI FIXED	RE50200077
VR14		1K 3P, SEMI FIXED	RE10200072
VR15		1K 3P, SEMI FIXED	RE10200072
VR16		10K 3P, SEMI FIXED	RE10300078
VR21		5K 3P, SEMI FIXED	RE50200077

### Resistors

Ref#	Bd Loc	Description	MFR. Part No.
R1		10K 1/4W (U) TYPE	RCU141034Z
R2		33K 1/4W (U) TYPE	RCU143334Z

<b>R3</b>		680ohm 1/4W (U) TYPE	RCU146814Z
<b>R4</b>		220ohm 1/4W (U) TYPE	RCU142214Z
<b>R5</b>		330ohm 1/4W (U) TYPE	RCU143314Z
<b>R6</b>		47K 1/4W (U) TYPE	RCU144734Z
<b>R7</b>		2.2 K 1/4W (U) TYPE	RCU142224Z
<b>R8</b>		330ohm 1/4W (U) TYPE	RCU143314Z
<b>R9</b>		56ohm 1/4W (U) TYPE	RCU145604Z
<b>R10</b>		100K 1/4W (U) TYPE	RCU141044Z
<b>R11</b>		10K 1/4W (U) TYPE	RCU141034Z
<b>R12</b>		6.8 K 1/4W (U) TYPE	RCU146824Z
<b>R13</b>		470K 1/4W (U) TYPE	RCU144744Z
<b>R14</b>		10K 1/4W (U) TYPE	RCU141034Z
<b>R15</b>		330ohm 1/4W (U) TYPE	RCU143314Z
<b>R16</b>		2.7 K 1/4W (U) TYPE	RCU142724Z
<b>R17</b>		1.8 K 1/4W (U) TYPE	RCU141824Z
<b>R18</b>		1 K 1/4W (U) TYPE	RCM141024A
<b>R19</b>		6.8 K 1/4W (U) TYPE	RCU146824Z
<b>R20</b>		100ohm 1/4W (U) TYPE	RCM141014A
<b>R21</b>		1 K 1/4W (U) TYPE	RCU141024Z
<b>R22</b>		1.5K 1/4W (U) TYPE	RCU141524Z
<b>R23</b>		2.7K 1/4W (U) TYPE	RCM142724A

<b>R24</b>		1.5K 1/4W (U) TYPE	RCU141524Z
<b>R25</b>		10K 1/4W (U) TYPE	RCM141034A
<b>R27</b>		1.8 K 1/4W (U) TYPE	RCU141824Z
<b>R28</b>		1.8 K 1/4W (U) TYPE	RCU141824Z
<b>R29</b>		47K 1/4W (U) TYPE	RCM144734A
<b>R30</b>		100ohm 1/4W (U) TYPE	RCM141014A
<b>R31</b>		100ohm 1/4W (U) TYPE	RCU141014Z
<b>R32</b>		100ohm 1/4W (U) TYPE	RCU141014Z
<b>R33</b>		100ohm 1/4W (U) TYPE	RCM141014A
<b>R34</b>		4.7K 1/4W (U) TYPE	RCM144724A
<b>R35</b>		6.8K 1/4W (U) TYPE	RCU146824Z
<b>R36</b>		6.8K 1/4W (U) TYPE	RCM146824A
<b>R37</b>		100ohm 1/4W (U) TYPE	RCU141014Z
<b>R38</b>		1K 1/4W (U) TYPE	RCU141024Z
<b>R39</b>		330K 1/4W (U) TYPE	RCU143344Z
<b>R40</b>		1 M 1/4W (U) TYPE	RCU141054Z
<b>R41</b>		6.8K 1/4W (U) TYPE	RCM146824A
<b>R42</b>		100K 1/4W (U) TYPE	RCU141044Z
<b>R43</b>		100K 1/4W (U) TYPE	RCU141044Z
<b>R44</b>		100K 1/4W (U) TYPE	RCU141044Z
<b>R45</b>		82K 1/4W (U) TYPE	RCU148234Z

<b>R46</b>		47K 1/4W (U) TYPE	RCM 144734A
<b>R47</b>		220K 1/4W (U) TYPE	RCU142244Z
<b>R48</b>		680K 1/4W (U) TYPE	RCU146844Z
<b>R49</b>		100K 1/4W (U) TYPE	RCM 141044A
<b>R50</b>		100 K1/4W (U) TYPE	RCM141044B
<b>R51</b>		220K 1/4W (U) TYPE	RCM142244A
<b>R52</b>		1 K, 1/4W (U) TYPE	RCU141024Z
<b>R53</b>		1 K, 1/4W (U) TYPE	RCU141024Z
<b>R54</b>		100K 1/4W (U) TYPE	RCM141044A
<b>R55</b>		100K 1/4W (U) TYPE	RCM141044A
<b>R56</b>		3.3K 1/4W (U) TYPE	RCM143324A
<b>R57</b>		3.3K 1/4W (U) TYPE	RCU143324Z
<b>R58</b>		3.3K 1/4W (U) TYPE	RCU143324Z
<b>R59</b>		47K 1/4W (U) TYPE	RCU144734Z
<b>R60</b>		3.3K 1/4W (U) TYPE	RCU143324Z
<b>R61</b>		3.3K 1/4W (U) TYPE	RCU143324Z
<b>R62</b>		10K 1/4W (U) TYPE	RCU141034Z
<b>R63</b>		47K 1/4W (U) TYPE	RCU144734Z
<b>R64</b>		2.7K 1/4W (U) TYPE	RCU142724Z
<b>R65</b>		1 K, 1/4W (U) TYPE	RCU141024Z
<b>R66</b>		10K 1/4W (U) TYPE	RCU141034Z

<b>R67</b>		1K, 1/4W (U) TYPE	RCU474157Z
<b>R68</b>		1K 1/4W (U) TYPE	RCM141024A
<b>R69</b>		1K, 1/4W (U) TYPE	RCU141024Z
<b>R70</b>		10K 1/4W (U) TYPE	RCM141034A
<b>R71</b>		47K 1/4W (U) TYPE	RCU144734Z
<b>R72</b>		6.8K 1/4W (U) TYPE	RCM146824A
<b>R73</b>		1K, 1/4W (U) TYPE	RCU141024Z
<b>R74</b>		100K 1/4W (P) TYPE	RCP141044Z
<b>R75</b>		680ohm 1/4W (U) TYPE	RCU146814Z
<b>R76</b>		1.5K 1/4W (U) TYPE	RCU141524Z
<b>R77</b>		10K 1/4W (U) TYPE	RCU141034Z
<b>R78</b>		2.8K 1/4W (U) TYPE	RCU142224Z
<b>R79</b>		2.7K 1/4W(UO TYPE	RCU142724Z
<b>R80</b>		100ohm 1/4W (U) TYPE	RCU141014Z
<b>R81</b>		2.2K 1/4W (U) TYPE	RCM142224A
<b>R82</b>		100K 1/4W (U) TYPE	RCU141044Z
<b>R84</b>		100ohm 1/4W (U) TYPE	RCU141014Z
<b>R85</b>		1.8K 1/4W (U) TYPE	RCU141824Z
<b>R86</b>		1 K 1/4W (U) TYPE	RCU141024Z
<b>R87</b>		5.6K 1/4W (U) TYPE	RCM145624A
<b>R88</b>		10K 1/4W (U) TYPE	RCU141034Z

<b>R89</b>		10K 1/4W (U) TYPE	RCM141034A
<b>R90</b>		1K 1/4W (U) TYPE	RCU141024Z
<b>R91</b>		10K 1/4W (U) TYPE	RCU141034Z
<b>R92</b>		1.5K 1/4W (U) TYPE	RCU141524Z
<b>R93</b>		680ohm 1/4W (U) TYPE	RCM146814B
<b>R94</b>		1.2K, 1/4W (U) TYPE	RCU141224Z
<b>R95</b>		8.2K 1/4W (U) TYPE	RCU148224Z
<b>R96</b>		22K 1/4W (U) TYPE	RCM142234B
<b>R97</b>		1.8K 1/4W (U) TYPE	RCU141824Z
<b>R98</b>		5.6K 1/4W (U) TYPE	RCU145624Z
<b>R99</b>		1K 1/4W (U) TYPE	RCU141024Z
<b>R100</b>		47K 1/4W (U) TYPE	RCM144734A
<b>R101</b>		1.5K 1/4W (U) TYPE	RCU141524Z
<b>R102</b>		220ohm 1/4W (U) TYPE	RCU142214Z
<b>R103</b>		100ohm 1/4W (U) TYPE	RCU141014Z
<b>R104</b>		100ohm 1/4W (U) TYPE	RCM141014A
<b>R105</b>		1M 1/4W (U) TYPE	RCU141054Z
<b>R106</b>		6.8K 1/4W (U) TYPE	RCU146824Z
<b>R107</b>		100K 1/4W (U) TYPE	RCU141044Z
<b>R108</b>		68K 1/4W (U) TYPE	RCU146834Z
<b>R709</b>		100K 1/4W (U) TYPE	RCU141044Z

<b>R110</b>		1.5M 1/4W (U) TYPE	RCU141554Z
<b>R111</b>		68K 1/4W (U) TYPE	RCU146834Z
<b>R712</b>		22K 1/4W (U) TYPE	RCM142234A
<b>R113</b>		2.7K 1/4W (U) TYPE	RCU142724Z
<b>R114</b>		680K 1/4W (U) TYPE	RCM146844A
<b>R115</b>		220K 1/4W (U) TYPE	RCU142244Z
<b>R116</b>		47K 1/4W (U) TYPE	RCU144734Z
<b>R117</b>		1K 1/4W (U) TYPE	RCU141024Z
<b>R118</b>		10K 1/4W (U) TYPE	RCM141034A
<b>R119</b>		10ohm 1/4W (U) TYPE	RCU141004Z
<b>R120</b>		1K 1/4W (U) TYPE	RCU141024Z
<b>R121</b>		27K 1/4W (U) TYPE	RCU142734Z
<b>R722</b>		1K 1/4W (U) TYPE	RCU141024Z
<b>R123</b>		10K 1/4W (U) TYPE	RCU141034Z
<b>R124</b>		10K 1/4W (U) TYPE	RCU141034Z
<b>R725</b>		100K 1/4W (U) TYPE	RCU141044Z
<b>R126</b>		10K 1/4W (U) TYPE	RCU141034Z
<b>R127</b>		1K 1/4W (U) TYPE	RCU141024Z
<b>R128</b>		220ohm 1/4W (U) TYPE	RCU142214Z
<b>R129</b>		10K 1/4W (U) TYPE	RCU141034Z
<b>R730</b>		10K 1/4W (U) TYPE	RCU141034Z

<b>R131</b>		10K 1/4W (U) TYPE	RCU141034Z
<b>R132</b>		100ohm 1/4W (U) TYPE	RCU141014Z
<b>R133</b>		10K 1/4W (U) TYPE	RCU141034Z
<b>R134</b>		10K 1/4W (U) TYPE	RCU141034Z
<b>R135</b>		220C21/4W (U) TYPE	RCU142214Z
<b>R136</b>		56ohm 1/4W (U) TYPE	RCU145604Z
<b>R137</b>		560ohm 1/4W (U) TYPE	RCU145614Z
<b>R138</b>		150ohm 1/4W (U) TYPE	RCU141514Z
<b>R139</b>		220K 1/4W (U) TYPE	RCU142244Z
<b>R140</b>		1.5K 1/4W (U) TYPE	RCM141524A
<b>R141</b>		100ohm 1/4W (U) TYPE	RCU141014Z
<b>R142</b>		1K 1/4W (U)TYPE	RCU141024Z
<b>R143</b>		10K 1/4W (U) TYPE	RCU141034Z
<b>R144</b>		330ohm 1/4W (U) TYPE	RCU143314Z
<b>R145</b>		10K 1/4W (U) TYPE	RCU141034Z
<b>R146</b>		10K 1/4W (U) TYPE	RCU141034Z
<b>R147</b>		1K 1/4W (U) TYPE	RCM141024A
<b>R148</b>		270K 1/4W (U)TYPE	RCM142744A
<b>R150</b>		270K 1/4W (U) TYPE	RCU142274Z
<b>R151</b>		3.3K 1/4W (U) TYPE	RCU143324Z
<b>R152</b>		4.7K 1/4W (U) TYPE	RCM144724A

<b>R153</b>		10K 1/4W (U) TYPE	RCU141034Z
<b>R154</b>		3.3K 1/4W (U) TYPE	RCU143324Z
<b>R155</b>		220ohm 1/4W (U) TYPE	RCM142214A
<b>R156</b>		100ohm 1/4W (U) TYPE	RCU141014Z
<b>R757</b>		1K 1/4W (P) TYPE	RCP141024Z
<b>R159</b>		10K 1/4W (U) TYPE	RCU141034Z
<b>R160</b>		330K 1/4W (U) TYPE	RCU143344Z
<b>R161</b>		220ohm 1/4W (U) TYPE	RCU142214Z
<b>R162</b>		100K 1/4W (U) TYPE	RCU141044Z
<b>R163</b>		470K 1/4W (U) TYPE	RCU144744Z
<b>R164</b>		15K 1/4W (U) TYPE	RCU141534Z
<b>R166</b>		10K 1/4W (U) TYPE	RCU141034Z
<b>R167</b>		100K 1/4W (U) TYPE	RCU141044Z
<b>R168</b>		47K 1/4W (U) TYPE	RCU144734Z
<b>R169</b>		10K 1/4W (U) TYPE	RCU141034Z
<b>R170</b>		10K 1/4W (U) TYPE	RCU141034Z
<b>R171</b>		1K, 1/4W (U) TYPE	RCU141024Z
<b>R172</b>		1K, 1/4W (U) TYPE	RCU141024Z
<b>R173</b>		47ohm 1/4W (U) TYPE	RCU144714Z
<b>R174</b>		3.3K 1/4W (U) TYPE	RCM143324A
<b>R175</b>		1.5K, 1/4W (U) TYPE	RCU141524Z

<b>R176</b>		2.7K 1/4W (U) TYPE	RCU142724Z
<b>R177</b>		10K 1/4W (U) TYPE	RCU141034Z
<b>R178</b>		3.3K 1/4W (U) TYPE	RCU143324Z
<b>R179</b>		1.5M 1/4W (U) TYPE	RCU141554Z
<b>R180</b>		10K 1/4W (P) TYPE	RCP252034Z
<b>R181</b>		10K 1/4W (U) TYPE	RCU141034Z
<b>R182</b>		3.3K 1/4W (U) TYPE	RCU143324Z
<b>R183</b>		3.3K 1/4W (U) TYPE	RCU143324Z
<b>R184</b>		1.8K 1/4W (U) TYPE	RCU141824Z
<b>R185</b>		100ohm 1/4W (U) TYPE	RCU141014Z
<b>R186</b>		3.3K 1/4W (U) TYPE	RCM143324A
<b>R788</b>		47K 1/4W (U) TYPE	RCU144734Z
<b>R189</b>		10K 1/4W (U) TYPE	RCM141034B
<b>R190</b>		10K 1/4W (U) TYPE	RCU141034Z
<b>R191</b>		220K 1/4W (U) TYPE	RCU142244Z
<b>R192</b>		100K 1/4W (U) TYPE	RCM141044A
<b>R193</b>		10K 1/4W (U) TYPE	RCU141034Z
<b>R194</b>		10K 1/4W (U) TYPE	RCU141034Z
<b>R195</b>		47K 1/4W (U) TYPE	RCM144734A
<b>R196</b>		680ohm 1/4W (U) TYPE	RCM146814A
<b>R197</b>		100ohm 1/4W (U) TYPE	RCU141014Z

<b>R198</b>		1.8K 1/4W (U) TYPE	RCU141824Z
<b>R199</b>		47K 1/4W (U) TYPE	RCU144734Z
<b>R200</b>		22K 1/4W (U) TYPE	RCU142234Z
<b>R201</b>		10K 1/4W (U) TYPE	RCU141034Z
<b>R202</b>		56ohm 1/4W (U)TYPE	RCM145604A
<b>R203</b>		10K 1/4W (U) TYPE	RCU141034Z
<b>R204</b>		560ohm 1/4W (U) TYPE	RCU145614Z
<b>R205</b>		2.7K 1/4W (U) TYPE	RCU142724Z
<b>R206</b>		100ohm 1/4W (U) TYPE	RCU141014Z
<b>R207</b>		22ohm 1/4W (U) TYPE	RCM142204A
<b>R208</b>		100ohm 1/4W (U) TYPE	RCU141014Z
<b>R209</b>		22ohm 1/4W (U) TYPE	RCU142204Z
<b>R210</b>		1K 1/4W (U )TYPE	RCU141024Z
<b>R211</b>		4.7K 1/4W (U) TYPE	RCU144724Z
<b>R212</b>		33K 1/4W (U) TYPE	RCU143334Z
<b>R213</b>		10K 1/4W (U) TYPE	RCM141034A
<b>R214</b>		10K 1/4W (U) TYPE	RCU141034Z
<b>R215</b>		3.3K 1/4W (U) TYPE	RCU143324Z
<b>R216</b>		10K 1/4W (U) TYPE	RCU141034Z
<b>R217</b>		10K 1/4W (U) TYPE	RCM141034A
<b>R218</b>		1 K 1/4W (U) TYPE	RCM141024A

<b>R219</b>		22K 1/4W (U) TYPE	RCU142234Z
<b>R220</b>		1K 1/4W (U) TYPE	RCU141024Z
<b>R221</b>		10K 1/4W (U) TYPE	RCU141034Z
<b>R222</b>		4.7K 1/4W (U) TYPE	RCM144724B
<b>R223</b>		6.8K 1/4W (U) TYPE	RCM146824A
<b>R224</b>		56ohm 1/4W (U) TYPE	RCU145604Z
<b>R225</b>		1K 1/4W (U) TYPE	RCM141024A
<b>R226</b>		10K 1/4W (U) TYPE	RCM141034A
<b>R227</b>		22K 1/4W (U) TYPE	RCU142234Z
<b>R228</b>		3.3K 1/4W (U) TYPE	RCU143324Z
<b>R229</b>		220K 1/4W (U) TYPE	RCU142244Z
<b>R230</b>		1K 1/4W (U) TYPE	RCU141024Z
<b>R231</b>		470K 1/4W (U) TYPE	RCU144744Z
<b>R232</b>		4.7K 1/4W (P) TYPE	RCP144724Z
<b>R233</b>		100ohm 1/4W (U) TYPE	RCU141014Z
<b>R234</b>		10K 1/4W (P) TYPE	RCP141034Z
<b>R235</b>		10K 1/4W (U) TYPE	RCU141034Z
<b>R236</b>		330ohm 1/4W (U) TYPE	RCU143314Z
<b>R237</b>		10K 1/4W (U) TYPE	RCU141034Z
<b>R238</b>		10K 1/4W (U) TYPE	RCU141034Z
<b>R239</b>		220ohm 1/4W (U) TYPE	RCU145614Z

<b>R240</b>		10K 1/4W (U) TYPE	RCM141034A
<b>R241</b>		1.8K 1/4W (U) TYPE	RCU141824Z
<b>R242</b>		100ohm 1/4W (U) TYPE	RCM141014A
<b>R243</b>		47K 1/4W (U) TYPE	RCU144734Z
<b>R244</b>		22K 1/4W (U) TYPE	RCU142234Z
<b>R245</b>		47K 1/4W (U) TYPE	RCU144734Z
<b>R247</b>		4.7K 1/4W (U) TYPE	RCU144724Z
<b>R248</b>		1K 1/4W (U) TYPE	RCU141024Z
<b>R250</b>		1K 1/4W (U)TYPE	RCM141024A
<b>R251</b>		10K 1/4W (P) TYPE	RCP121034Z
<b>R252</b>		1K 1/4W (U) TYPE	RCM141024A
<b>R253</b>		18ohm 1/4W (U) TYPE	RCU141804Z
<b>R254</b>		1ohm 1/4W (P) TYPE	RCP141094Z
<b>R255</b>		150ohm 1/2W (P)	RCP121514Z
<b>R256</b>		18ohm 1/4W (U) TYPE	RCU141804Z
<b>R257</b>		150ohm 1/2W (P) TYPE	RCP121514Z
<b>R258</b>		2.2ohm 1/4W (P) TYPE	RCP142294Z
<b>R259</b>		150ohm 1/4W (U) TYPE	RCU141514Z
<b>R260</b>		4.7ohm 1/4W (U) TYPE	RCU144794Z
<b>R261</b>		1.5K 1/4W (U) TYPE	RCU141524Z
<b>R262</b>		330ohm 1/4W (U) TYPE	RCU143314Z

<b>R264</b>		47ohm 1/4W (U) TYPE	RCU144704Z
<b>R265</b>		330ohm 1/4W (U) TYPE	RCU143314Z
<b>R266</b>		1.5K 1/4W (U) TYPE	RCU141524Z
<b>R268</b>		1 K 1/4W (U) TYPE	RCU141024Z
<b>R269</b>		100K 1/4W (U) TYPE	RCU141044Z
<b>R270</b>		100K 1/4W (U) TYPE	RCU141044Z
<b>R272</b>		100K 1/4W (U) TYPE	RCU141044Z
<b>R273</b>		100ohm 1/4W (U) TYPE	RCU141014Z
<b>R274</b>		10K 1/4W (U) TYPE	RCU141034Z
<b>R276</b>		150ohm 1/4W (U) TYPE	RCU141514Z
<b>R277</b>		1.8K 1/4W (U) TYPE	RCU141824Z
<b>R278</b>		10K 1/4W (U) TYPE	RCU141034Z
<b>R279</b>		100ohm 1/4W (U) TYPE	RCM141014A
<b>R280</b>		4.7K 1/4W (U) TYPE	RCM144724A
<b>R281</b>		4.7K 1/4W (U) TYPE	RCU144724Z
<b>R282</b>		4.7K 1/4W (P) TYPE	RCP144724Z
<b>R283</b>		10K 1/4W (U) TYPE	RCM141034A
<b>R284</b>		1K, 1/4W (U) TYPE	RCU141024Z
<b>R285</b>		470ohm 1/4W (U) TYPE	RCU144714Z
<b>R286</b>		15ohm 1/4W (U) TYPE	RCU141504Z
<b>R287</b>		2.7K 1/4W (U) TYPE	RCU142724Z

<b>R289</b>		470ohm 1/4W (U) TYPE	RCU144714Z
<b>R290</b>		10K 1/4W (U) TYPE	RCU141034Z
<b>R291</b>		10K 1/4W (U) TYPE	RCU141034Z
<b>R292</b>		4.7K 1/4W (U) TYPE	RCM144724B
<b>R293</b>		10K 1/4W (U) TYPE	RCU141034Z
<b>R294</b>		4.7K 1/4W (U) TYPE	RCU144724Z
<b>R295</b>		10K 1/4W (U) TYPE	RCU141034Z
<b>R296</b>		10K 1/4W (U) TYPE	RCU141034Z
<b>R297</b>		10ohm 1/4W (U) TYPE	RCU141004Z
<b>R298</b>		1K 1/4W (U) TYPE	RCU141024Z
<b>R299</b>		10K 1/4W(U) TYPE	RCU141034Z
<b>R300</b>		560ohm 1/4W (U) TYPE	RCU145614Z
<b>R301</b>		6.8K 1/4W (U) TYPE	RCU146824Z
<b>R302</b>		1K 1/4W (P) TYPE	RCP141024Z
<b>R303</b>		10K 1/4W (U) TYPE	RCU141034Z
<b>R304</b>		1ohm 1/4W (P) TYPE	RCP141094Z
<b>R305</b>		220ohm 1/4W (U) TYPE	RCM142214
<b>R306</b>		10K 1/4W (U) TYPE	RCU141034Z
<b>R307</b>		1K 1/4W (U) TYPE	RCU141024Z
<b>R308</b>		100ohm 1/4W (U) TYPE	RCU141014Z
<b>R309</b>		27K 1/4W (U) TYPE	RCU142734Z

<b>R310</b>		270K 1/4W (U) TYPE	RCU142274Z
<b>R311</b>		1 K 1/4W (U) TYPE	RCM141024
<b>R312</b>		1 K, 1/4W (U) TYPE	RCU141024Z
<b>R313</b>		1 K, 1/4W (U) TYPE	RCU141024Z
<b>R314</b>		10K 1/4W (U) TYPE	RCU141034Z
<b>R315</b>		22K 1/4W (U) TYPE	RCU142234Z
<b>R317</b>		1K, 1/4W (U)TYPE	RCU141024Z
<b>R318</b>		100ohm 1/4W (U) TYPE	RCM141014
<b>R319</b>		1K, 1/4W (U)TYPE	RCU141024
<b>R321</b>		10K 1/4W (U) TYPE	RCU141034
<b>R322</b>		100K 1/4W (U) TYPE	RCM141044A
<b>R323</b>		33K 1/4W (U) TYPE	RCU143334Z
<b>R324</b>		4.7K 1/4W (U) TYPE	RCM144724A
<b>R325</b>		10K 1/4W (U) TYPE	RCU141034Z
<b>R326</b>		1K 1/4W (U) TYPE	RCM141024A
<b>R327</b>		10K 1/4W (U) TYPE	RCU141034Z
<b>R330</b>		1K 1/4W (U) TYPE	RCU141024Z
<b>R331</b>		10K 1/4W (U) TYPE	RCM141034A
<b>R332</b>		1K 1/4W (U) TYPE	RCU141024Z
<b>R334</b>		100ohm 1/4W (U) TYPE	RCM141014B
<b>R335</b>		10K 1/4W (U) TYPE	RCU141034Z

<b>R336</b>		10K 1/4W (U) TYPE	RCM141034A
-------------	--	-------------------	------------

[www.radioaficion.com](http://www.radioaficion.com)

**RCI 2950 PARTS LISTS** IC's, Transistors**Main PCB (EPT295013Z)  
Integrated Circuits**

<b>Ref#</b>	<b>Bd Loc</b>	<b>Description</b>	<b>MFR. Part No.</b>
<b>IC1</b>		I.C. NJM324D	ENJR00324D
<b>IC2</b>		I.C. UPC1028H	ENNE01028H
<b>IC3</b>		I.C. AN612	ENMA00612Z
<b>IC4</b>		I.C. NJM7805	ENJR07805Z
<b>IC5</b>		I.C. TC5081AP	ENTA05081A
<b>IC6</b>		I.C. NJM7808A	ENJR07808A
<b>IC7</b>		I.C. TC5081AP	ENTA05081A
<b>IC8</b>		I.C. TA731 0P	ENTA07310P
<b>IC9</b>		I.C. TA7310P	ENTA07310P
<b>IC10</b>		I.C. TA7310P	ENTA07310P
<b>IC11</b>		I.C. TC5082P	ENTA05082P
<b>IC12</b>		I.C. HD10551	ENH110551Z
<b>IC13</b>		I.C. HD10551	ENH110551Z
<b>IC14</b>		I.C. TA7310P	ENTA07310P
<b>IC15</b>		I.C. NJM7808A	ENJR07808A
<b>IC16</b>		I.C. JRC4558D	ENJR04558D
<b>IC17</b>		I.C. CX7925B	ENS0079258

<b>IC19</b>		I.C. TA7222AP	ENTA07222A
<b>IC21</b>		I.C. TC4069UBP	ENTA04069U

**Transistors**

<b>Ref#</b>	<b>Bd Loc</b>	<b>Description</b>	<b>MFR. Part No.</b>
<b>Q1</b>		2SC1675K	T2SC01675K
<b>Q2</b>		2SC1675K	T2SC01675K
<b>Q3</b>		2SC945P	TRSC00945P
<b>Q4</b>		2SC945P	TRSC00945P
<b>Q5</b>		2SC945P	TRSC00945P
<b>Q6</b>		2SA733P	T2SA00733P
<b>Q7</b>		2SC945P	TRSC00945P
<b>Q8</b>		2SC1674K	T2SC01674K
<b>Q9</b>		2SC1675K	T2SC01675K
<b>Q10</b>		2SC1675K	T2SC01675K
<b>Q11</b>		2SC1675K	T2SC01675K
<b>Q12</b>		2SA733P	T2SA00733P
<b>Q13</b>		2SC945P	TRS000945P
<b>Q14</b>		2SC945P	TRSC00945P
<b>Q15</b>		2SC945P	TRSC00945P
<b>Q16</b>		2SC945P	TRSC00945P

<b>Q17</b>		2SC945P	TRSC00945P
<b>Q18</b>		2SC1674K	T2SC01674K
<b>Q19</b>		J310	EZZJ00310Z
<b>Q20</b>		2SC1674K	T2SC01674K
<b>Q21</b>		2SC1675K	T2SC01675K
<b>Q22</b>		2SC1675K	T2SC01675K
<b>Q23</b>		2SC1906	T2SC01906Z
<b>Q24</b>		2SC945P	TRSC00945P
<b>Q25</b>		2SA733P	T2SA00733P
<b>Q26</b>		2SC945P	TRSC00945P
<b>Q27</b>		2SC1675K	T2SC01675K
<b>Q28</b>		2SC1675K	T2SC01675K
<b>Q29</b>		2SC1675K	T2SC01675K
<b>Q30</b>		2SC945P	TRSC00945P
<b>Q31</b>		2SA733P	T2SA00733P
<b>Q32</b>		2SC945P	TRSC00945P
<b>Q33</b>		2SC945P	TRSC00945P
<b>Q34</b>		2SC945P	TRSC00945P
<b>Q35</b>		2SA733P	T2SA00733P
<b>Q36</b>		2SC945P	TRSC00945P
<b>Q37</b>		2SA9340	T2SA009340

<b>Q38</b>		2SA9340	T2SA009340
<b>Q39</b>		2SC945P	TRSC00945P
<b>Q40</b>		2SA9340	T2SA009340
<b>Q41</b>		2SC945P	TRSC00945P
<b>Q42</b>		2SC945P	TRSC00945P
<b>Q43</b>		2SC1675K	T2SC01675K
<b>Q44</b>		2SC1675K	T2SC01675K
<b>Q45</b>		2SA733P	T2SA00733P
<b>Q46</b>		2SC2312	T2SC02312C
<b>Q47</b>		2SC2312	T2SC02312C
<b>Q48</b>		2SC2166C	T2SC02166C
<b>Q49</b>		2SC2314F	T2SC02314F
<b>Q50</b>		2SC1906	T2SC01906Z
<b>Q51</b>		2SB754Y	T2SB00754Y
<b>Q53</b>		2SA473/0	T2SA004730
<b>Q52</b>		2SC945P	TRSC00945P
<b>Q54</b>		2SC945P	TRSC00945P
<b>Q55</b>		2SC945P	TRSC00945P
<b>Q56</b>		2SC945P	TRSC00945P
<b>Q57</b>		2SC945P	TRSC00945P
<b>Q58</b>		2SC945P	TRSC00945P

## RCI 2950 PARTS LISTS Diodes

### Main PCB (EPT295013Z) Diodes

Ref#	Bd Loc	Description	MFR. Part No.
D1		DIODE 1N60P	ED1N00060P
D2		DIODE 1N60P	ED1N00060P
D3		DIODE 1N4148	ED1N04148Z
D4		DIODE 1N4148	ED1N04148Z
D5		DIODE 1N4148	ED1N04148Z
D6		DIODE 1N4148	ED1N04148Z
D7		DIODE 1N4148	ED1N04148Z
D8		DIODE 1N4148	E01N04148Z
D9		DIODE 1N4148	ED1N04148Z
D10		DIODE 1N4148	ED1N04148Z
D11		DIODE 1N60P	ED1N00060P
D12		DIODE 1N60P	ED1N00060P
D13		DIODE 1N4148	ED1N04148Z
D14		DIODE 1N4148	ED1N04148Z
D15		DIODE 1N4148	ED1N04148Z
D16		DIODE 1N4148	ED1N04148Z
D17		DIODE 1N4148	ED1N04148Z

<b>D18</b>		DIODE MC301	EDMC00301Z
<b>D19</b>		DIODE FC54M	EDECO0054M
<b>D20</b>		DIODE MC301	EOMC00301Z
<b>D21</b>		DIODE 1N4148	E01N04148Z
<b>D22</b>		DIODE 1N4148	E01N04148Z
<b>D23</b>		DIODE FC54M	EDECO0054M
<b>D24</b>		DIODE FC54M	EDECO0054M
<b>D25</b>		DIODE MC301	EDMC00301Z
<b>D26</b>		DIODE 1N4148	ED1N04148Z
<b>D27</b>		DIODE 1N4148	ED1N04148Z
<b>D28</b>		DIODE 1N4148	ED1N04148Z
<b>D29</b>		DIODE 1N4148	ED1N04148Z
<b>D30</b>		DIODE 1N4148	ED1N04148Z
<b>D31</b>		DIODE 1N4148	ED1N04148Z
<b>D32</b>		DIODE 1N4148	ED1N04148Z
<b>D33</b>		DIODE 1N4148	ED1N04148Z
<b>D34</b>		DIODE 1N60P	ED1NO0060P
<b>D35</b>		DIODE 1N60P	E01NO0060P
<b>D36</b>		DIODE 1N4148	ED1N04148Z
<b>D37</b>		DIODE 1N4148	E01N04148Z
<b>D38</b>		DIODE 1N4148	ED1N04148Z

<b>D38</b>		DIODE 1N4148	ED1N04148Z
<b>D39</b>		DIODE 1N4148	ED1N04148Z
<b>D40</b>		DIODE 1N4148	ED1N04148Z
<b>D41</b>		DIODE 1N4148	ED1N04148Z
<b>D42</b>		DIODE KB362	EDKB00362Z
<b>D43</b>		DIODE FC54M	EDECO0054M
<b>D44</b>		DIODE 1N4148	ED1N04148Z
<b>D45</b>		DIODE 1N4148	E01N04148Z
<b>D46</b>		DIODE 1N4148	ED1N04148Z
<b>D47</b>		DIODE 1N4148	ED1N04148Z
<b>D48</b>		DIODE 1N4148	ED1N04148Z
<b>D49</b>		DIODE 1N4148	ED1N04148Z
<b>050</b>		DIODE 1N4148	ED1N04148Z
<b>D51</b>		DIODE KB262	EDKB00262Z
<b>D52</b>		DIODE 1N4148	ED1N04148Z
<b>D53</b>		DIODE 1N4148	ED1N04148Z
<b>D54</b>		DIODE 1N4148	ED1N04148Z
<b>D55</b>		DIODE 1N4148	ED1N04148Z
<b>D56</b>		DIODE 1N4148	ED1N04148Z
<b>D57</b>		DIODE 1N4148	ED1N04148Z
<b>D58</b>		DIODE 1N4148	ED1N04148Z

<b>D59</b>		DIODE 1N4148	ED1N04148Z
<b>D60</b>		DIODE 1N4148	ED1N04148Z
<b>D61</b>		DIODE 1N4148	ED1N04148Z
<b>D62</b>		DIODE 1N4148	ED1N04148Z
<b>063</b>		DIODE 1N4148	ED1N04148Z
<b>D64</b>		DIODE 1N4148	ED1N04148Z
<b>D65</b>		DIODE 1N4148	ED1N04148Z
<b>D66</b>		DIODE SVC251	EDSV00251Z
<b>D67</b>		DIODE SVC251	EDSV00251Z
<b>D68</b>		DIODE 1N4148	ED1N04148Z
<b>D69</b>		DIODE 1N4148	ED1N04148Z
<b>D70</b>		DIODE 1N4148	ED1N04148Z
<b>D71</b>		DIODE 1N4148	E01N04148Z
<b>D72</b>		DIODE 1N4148	ED1N04148Z
<b>D73</b>		DIODE, .5W 2.4V, ZENER	EDZD05249Z
<b>D74</b>		DIODE, .5W 5.6V, ZENER	EDZD05249Z
<b>D75</b>		DIODE KS362	EDKB00362Z
<b>D76</b>		DIODE 1N4148	ED1N04148Z
<b>D77</b>		DIODE 1N4148	ED1N04148Z
<b>D78</b>		DIODE 1N4148	ED1N04148Z
<b>D79</b>		DIODE 1N4148	ED1N04148Z

<b>D80</b>		DIODE 1N4148	ED1N04148Z
<b>D81</b>		DIODE 1N60P	EDINO0060P
<b>082</b>		DIODE 1N4148	ED1N04148Z
<b>D83</b>		DIODE 1N4148	ED1N04148Z
<b>D84</b>		DIODE 1N4148	ED1N04148Z
<b>085</b>		DIODE 1N4148	ED1N04148Z
<b>D86</b>		DIODE, .5W 5.6V. ZENER	EDZD05569Z
<b>D87</b>		DIODE FC54M	EDECO0054M
<b>D88</b>		DIODE 1N4148	ED1N04148Z
<b>D89</b>		DIODE 1N4148	ED1N04148Z
<b>D90</b>		DIODE MV1Y	EDMV00001Y
<b>D91</b>		DIODE MV1Y	EDMV00001Y
<b>D92</b>		DIODE MV1Y	EDMV00001Y
<b>D93</b>		DIODE 1N4148	EDIN04148Z
<b>D94</b>		DIODE FC54M	EDECO0054M
<b>D95</b>		DIODE FC54M	EDECO0054M
<b>D96</b>		DIODE FC54M	EDECO0054M
<b>D97</b>		DIODE 1N4148	ED1N04148Z
<b>D98</b>		DIODE 1N4148	ED1N04148Z
<b>D99</b>		DIODE 1N4148	ED1N04148Z
<b>D100</b>		DIODE 1N4148	ED1N04148Z

<b>D101</b>		DIODE 1N4148	ED1N04148Z
<b>D102</b>		DIODE 1N4148	ED1N04148Z
<b>D103</b>		DIODE 1N4148	ED1N04148Z
<b>D104</b>		DIODE 1N4003	ED1N04003Z
<b>D105</b>		DIODE 1N4003	ED1N04003Z
<b>D106</b>		DIODE 1N4148	ED1N04148Z
<b>D107</b>		DIODE 1N4148	ED1N04148Z
<b>D108</b>		DIODE 1N4148	ED1N04148Z
<b>D109</b>		DIODE 1N4148	E01N04148Z
<b>D110</b>		DIODE 1N4148	E01N04148Z
<b>D111</b>		DIODE FC54M	EDECO0054M
<b>D112</b>		DIODE 1N4148	ED1N04148Z
<b>D113</b>		DIODE 1N4148	ED1N04148Z
<b>D116</b>		DIODE MC301	EDMC00301

**RCI 2950 PARTS LISTS** Wire, Jumpers, Connectors**Connectors**

<b>Ref#</b>	<b>Bd Loc</b>	<b>Description</b>	<b>MFR. Part No.</b>
J101		PCB CONN. SOCKET 2P L= 17.8	EX07N48185
J104		PCB CONNECTOR SOCKET 3P	EX07N41216
J105		PCB CONNECTOR SOCKET 2P	EX07N41226
J107		PCB CONNECTOR SOCKET 2P	EX07N41226
J108		PCB CONNECTOR SOCKET 2P	EX07N41226
J109		PCB CONNECTOR SOCKET 3P	EX07N41216
J110		PCB CONNECTOR SOCKET 3P	EX07N41216
J112		PCB CONNECTOR SOCKET 3P	EX07N41216
J113		PCB CONNECTOR SOCKET 6P	EX07N41266
J115		PCB CONNECTOR SOCKET 3P	EX07N41216
J116		PCB CONNECTOR SOCKET 3P	EX07N41216
J117		PCB CONNECTOR SOCKET 7P	EX07N41261
J118		PCB CONNECTOR SOCKET 3P	EX07N41216
J119		PCB CONNECTOR SOCKET 6P	EX07N41266
J501		EARPHONE JACK	EXO6N41045

<b>J502</b>		EARPHONE JACK	EXO6N41045
<b>J503</b>		EARPHONE JACK	EX06N41045

**Jumper Wires**

<b>Ref#</b>	<b>Bd Loc</b>	<b>Description</b>	<b>MFR. Part No.</b>
<b>J1</b>		JUMPER WIRE 7x5x7mm	WX01070705
<b>J2</b>		JUMPER WIRE 7x13x7mm	WX01070713
<b>J3</b>		JUMPER WIRE 7x13x7mm	WX01070713
<b>J5</b>		JUMPER WIRE 7x10x7mm	WX01070710
<b>J6</b>		JUMPERWIRE 7x10x7mm	WX01070710
<b>J7</b>		JUMPER WIRE 7x10x7mm	WX01070710
<b>J8</b>		JUMPER WIRE 7x6x7mm	WX01070706
<b>J9</b>		JUMPER WIRE 7x10x7mm	WX01070710
<b>J10</b>		JUMPER WIRE 7x10x7mm	WX01070710
<b>J12</b>		JUMPER WIRE 7x9x7mm	WX01070709
<b>J13</b>		JUMPER WIRE 7x5x7mm	WX01070705
<b>J14</b>		JUMPER WIRE 7x7x7mm	WX01070707
<b>J16</b>		JUMPER WIRE 7x5x7mm	WX01070705
<b>J17</b>		JUMPER WIRE 7x10x7mm	WX01070710

<b>J18</b>		JUMPER WIRE 7x13x7mm	WX01070713
<b>J19</b>		JUMPER WIRE 7x4x7mm	WX01070704
<b>J20</b>		JUMPER WIRE 7x6x7mm	WX01070706
<b>J21</b>		JUMPER WIRE 7x10x7mm	WX01070710
<b>J22</b>		JUMPER WIRE 7x6x7mm	WX01070706
<b>J23</b>		JUMPER WIRE 7x6x7mm	WX01070706
<b>J24</b>		JUMPER WIRE 7x6x7mm	WX01070706
<b>J25</b>		JUMPER WIRE 7x6x7mm	WX01070706
<b>J26</b>		JUMPER WIRE 7x6x7mm	WX01070706
<b>J27</b>		JUMPER WIRE 7x10x7mm	WX01070710
<b>J28</b>		JUMPER WIRE 7x9x7mm	WX01070709
<b>J29</b>		JUMPER WIRE 7x4x7mm	WX01070704
<b>J30</b>		JUMPER WIRE 7x5x7mm	WX01070705
<b>J31</b>		JUMPER WIRE 7x7x7mm	WX01070707
<b>J32</b>		JUMPER WIRE 7x6x7mm	WX01070706
<b>J33</b>		JUMPER WIRE 7x10x7mm	WX01070710
<b>J34</b>		JUMPER WIRE 7x10x7mm	WX01070710
<b>J36</b>		JUMPER WIRE 7x9x7mm	WX01070709
<b>J38</b>		JUMPER WIRE 7x3x7mm	WX01070703

<b>J39</b>		JUMPER WIRE 7x27x7mm	WX01070727
<b>J40</b>		JUMPER WIRE 7x10x7mm	WX01070710
<b>J41</b>		JUMPER WIRE 7x5x7mm	WX01070705
<b>J42</b>		JUMPER WIRE 7x10x7mm	WX01070710
<b>J43</b>		JUMPER WIRE 7x9x7mm	WX01070709
<b>J44</b>		JUMPER WIRE 7x10x7mm	WX01070710
<b>J45</b>		JUMPER WIRE 7x10x7mm	WX01070710
<b>J46</b>		JUMPER WIRE 7x13x7mm	WX01070713
<b>J47</b>		JUMPER WIRE 7x5x7mm	WX01070705
<b>J48</b>		JUMPER WIRE 7x5x7mm	WX01070705
<b>J49</b>		JUMPER WIRE 7x10x7mm	WX01070710
<b>J50</b>		JUMPER WIRE 7x10x7mm	WX01070710
<b>J51</b>		JUMPER WIRE 7x10x7mm	WX01070710
<b>J53</b>		JUMPER WIRE 7x5x7mm	WX01070705
<b>J54</b>		JUMPER WIRE 7x6x7mm	WX01070706
<b>J55</b>		JUMPER WIRE 7x5x7mm	WX01070705
<b>J57</b>		JUMPER WIRE 7x4x7mm	WX01070704
<b>J58</b>		JUMPER WIRE 7x10x7mm	WX01070710
<b>J59</b>		JUMPER WIRE 7x5x7mm	WX01070705

<b>J60</b>		JUMPER WIRE 7x6x7mm	WX01070706
<b>J61</b>		JUMPER WIRE 7x6x7mm	WX01070706
<b>J62</b>		JUMPER WIRE 7x4x7mm	WX01070704
<b>J63</b>		JUMPER WIRE 7x8x7mm	WX01070708
<b>J64</b>		JUMPER WIRE 7x10x7mm	WX01070710
<b>J66</b>		JUMPER WIRE 7x10x7mm	WX01070710
<b>J67</b>		JUMPER WIRE 7x14x7mm	WX01070714
<b>J68</b>		JUMPER WIRE 7x6x7mm	WX01070706
<b>J69</b>		JUMPER WIRE 7x10x7mm	WX01070710
<b>J70</b>		JUMPER WIRE 7x5x7mm	WX01070705
<b>J71</b>		JUMPER WIRE 7x4x7mm	WX01070704
<b>J72</b>		JUMPER WIRE 7x5x7mm	WX01070705
<b>J73</b>		JUMPER WIRE 7x5x7mm	WX01070705
<b>J74</b>		JUMPER WIRE 7x10x7mm	WX01070710
<b>J75</b>		JUMPER WIRE 7x8x7mm	WX01070708
<b>J76</b>		JUMPER WIRE 7x7x7mm	WX01070707
<b>J78</b>		JUMPER WIRE 7x7x7mm	WX01070707
<b>J79</b>		JUMPER WIRE 7x6x7mm	WX01070706
<b>J80</b>		JUMPER WIRE 7x6x7mm	WX01070706

<b>J81</b>		JUMPER WIRE 7x13x7mm	WX01070713
<b>J82</b>		JUMPER WIRE 7x15x7mm	WX01070715
<b>J83</b>		JUMPER WIRE 7x7x7mm	WX01070707
<b>J84</b>		JUMPER WIRE 7x14x7mm	WX01070714
<b>J86</b>		JUMPER WIRE 7x5x7mm	WX01070705
<b>J114</b>		JUMPER WIRE 7x3x7mm	WX01070703
<b>J322</b>		JUMPER WIRE 7x5x7mm	WX01070705
<b>ANT</b>		JUMPER WIRE 7x50x7mm	WX01070750

**RCI 2950 PARTS LISTS Chassis, Mechanical & Misc.****RCI-2950 CHASSIS PARTS**

<b>Ref#</b>	<b>Description</b>	<b>MFR. Part No.</b>
-	SPEAKER, 3W 8 OHM, 3 1/2"	ES300835SQ
-	FUSE, 7A, 16V	EX02N40210
-	DC CORD W/FUSE SOCKET	WA0012185A
-	DC SOCKET, 3P	EX06N40007
-	ANT JACK	EX06 N41019
-	MICROPHONEASSY	EX04N40620
<b>SP</b>	WIRE CONN. HOUSING, 2P	EX07N48041
<b>J105</b>	WIRE CONN. HOUSING, 2-2P	EX07N48391
<b>J108</b>	WIRE CONN. HOUSING, 2-2P	EX07N48391
<b>J109</b>	WIRE CONN. HOUSING, 3-3P	EX07N48389
<b>J112</b>	WIRE CONN. HOUSING, 3-3P	EX07N48389
<b>J113</b>	WIRE CONN. HOUSING, 6P	EX07N48396
<b>J115</b>	WIRE CONN. HOUSING, 3-3P	EX07N48389
<b>J116</b>	WIRE CONN. HOUSING, 3-3P	EX07N48389
<b>J117</b>	WIRE CONN, HOUSING, 7P	EX07N48387
<b>J119</b>	WIRE CONN. HOUSING, 3-3P	EX07N48389
<b>J501</b>	WIRE CONN. HOUSING, 2-2P	EX07N48391

<b>J502</b>	WIRE CONN. HOUSING, 3-3P	EX07N48389
<b>J503</b>	WIRE CONN. HOUSING, 3-3P	EX07N48389
<b>J504</b>	WIRE CONN. HOUSING, 3-3P	EX07N48389
<b>J508</b>	WIRE CONN. HOUSING, 2-2P	EX07N48391
<b>J602</b>	WIRE CONN. HOUSING, 3-3P	EX07N48389
<b>J601</b>	WIRE CONN. HOUSING, 3-3P	EX07N48389
<b>J701</b>	WIRE CONN. HOUSING, 2-3-2-3P	EX07N48397
<b>J702</b>	WIRE CONN. HOUSING, 2-3-2-3P	EX07N48397
<b>J703</b>	WIRE CONN. HOUSING, 2-3-2-3P	EX07N48397
-	WIRE CONN. HOUSING 2-4-2P	EX07N48398
-	WIRE CONN. HOUSING 3-2-2P	EX07N48394

**RELAY**

<b>Ref#</b>	<b>Bd Loc</b>	<b>Description</b>	<b>MFR. Part No.</b>
<b>RL1</b>		RELAY 9V	EX05N40802

<b>Ref#</b>	<b>Description</b>	<b>MFR. Part No.</b>
-	FRONT PANEL, BLACK	PT29S0010A
-	REFRACTOR PLATE (KEY)	PT2950030A
-	REFRACTOR PLATE (LCD)	FIT2950041A

-	KNOB, BLACK	PT2950051A
-	KNOB, BLACK	PT2950060A
-	INNER KNOB, BLACK	PT2950071A
-	OUTER KNOB, BLACK	PT2950080A
-	LCD WINDOW	PT2950090A
-	PVC BAG SHIELD PLATE A	PT1200020A
-	FRONT PANEL, BLACK	PT2950010B
-	FRONT PANEL, BLACK	PT2950010C
-	FRONT PANEL, BLACK	PT2950010D
-	FRONT CHASSIS	MT2950010P
-	SPACE KING	MT2950020E
-	D SPRING A #6600	MT3600080T
-	D SPRING 8 #7800	MT3600090T
-	D SPRING D #8500	MT3600100T
-	HANDLER, BLACK	MT3600030A
-	TOP HOUSING, BLACK	MT2950031A
-	BOTTOM HOUSING, BLACK	MT2950041A
-	SET CHASSIS	MT3600022X
-	SOCKET HOLDER	MT3600050X
-	SHIELD PLATE (A)	MT1200060N
-	HEAT SINK, BLACK	MM7878040X

-	PC.B BRACKET	MT3600010S
-	SHIELD PLATE	MT2710060X
-	TOP HOUSING	MT2950031B
-	RUBBER KEY	QT2950010A
-	MIC PLATE	BT2100020A
-	MIC PLATE	BT2100020D
-	MIC PLATE	STOSSBO10B
-	SHIELD CLOTH 10x88x.3t	LZZZ60001Z
-	SHIELD CLOTH 90x90x.18t	LZZZ60056Z
-	QC LABEL	177761009Z
-	SER NO. LABEL	LZZZ61155Z
-	LCD SPONGE RUBBER 108x25x1T	XZZZ290205Z
-	CLAMP	GZZZ50000Z
-	SILICA GEL	GZZZ50010Z
-	BEEP SPONGE 22x1.5t	XZZZ90206Z
-	FOAM 14x16x20mm	XZZZ90004Z
-	PCB STOPPER	XZZZ90006Z
-	INSULATING PLATE	XZZZ90020Z
-	INSULATING RING	XZZZ90003Z
-	ANT/M IC SOLD. PLATE 16x21x.5t	XZZZ90098Z
-	SPONGE 15x30x1 It	XZZZ90021Z

-	SOLD. PLATE	XZZZ90002Z
-	LCD PCB SHIELD PLATE 35x8x2t	XZZZ90187Z
-	RCI MIC PLATE	BT6300041A
-	LAMP REFRACTOR LABEL 28x11	LZZZ61278Z
-	TOP REFRACTOR LABEL 25x8	LZZZ61277Z
-	LCD REFRACTOR LABEL 100x11	LZZZ61276Z
-	POLYLON (TOP)	UPT360001A
-	POLYLON (BOTTOM)	UPT360001B
<b>B754Y</b>	SCREW, M2.0x0.4px10 FAN HEAD	JS052010MN
<b>TR46</b>	SCREW, M2.0x0.4px12 PAN HEAD	JS052012MN
<b>TR47</b>	SCREW, M2.0x0.4px12 PAN HEAD	JS052012MN
<b>TR48</b>	SCREW, M2.0x0.4px12 FAN HEAD	JS052012MN
-	FRONT PANEL (4) SCREW M3.0x0.5px6, FLAT HEAD	JS033006MN
-	DC SOCKET (2), SET CHASSIS(12) LCD & CPU PCB (6) SCREW M3.0x0.5px6, PAN HEAD TA7222(1)	JS053006MN
-	SCREW, M3.0x0.5px6 (PVC) ROUND HEAD	JS013006MY
-	MAIN PCB (5) SCREW, T3x6-2 PAN HEAD	JS053006TN
-	HEAT SINK SCREW, T3x8-2 ROUND HEAD	JS013008TN
-	SPEAKER (4) SCREW M3.0x0.5px8 PAN HEAD	JS053008MN
-	T7808 KEY PCB (2) SCREW M3.0x0.5px10 PAN HEAD	JS053010MN
-	R7808(1) KEY PCB (2) SCREW M3.0x0.5px10 PAN HEAD	JS053010MN
-	C7808x2 SCREW M2.0x0.4px8 PAN HEAD	JS052008MN

-	SPEAKER (4) NUT WIWASHER	JN263035ZS
-	2SC2312 (3) NUT	JN242012ZS
-	INSULATING RING	XZZZ90072Z
-	MOUNTING SCREW M5.0x0.8x11 BLACK	XZZZ90007Z
-	MICROPHONE STOPPER	XZZZ90008Z
-	SCREW 5x10-1 STEEL	JS015010WH
-	SCREW 3.5x8-2	JS013508TH
-	OUTSIDE TOOTH WASHER 5.5x10x0.3	JW315510CN
-	INSIDE TOOTH WASHER 4x8x0.3	JW324008CN
-	FIBER WASHER 4.9x15x1T	XZZZ90188Z

## MODIFY YOUR RCI FOR 26 Mhz -32 Mhz OPERATION

The RCI was designed to be a wide range transceiver. It is really. With a nice little modification you can expand this rig from 26 Mhz to 32 Mhz.

All you have to do is to locate a black jumper onto the LCD electric board. This jumper is called S601. Just move it to the other position.

# 26-32 Mhz Mod

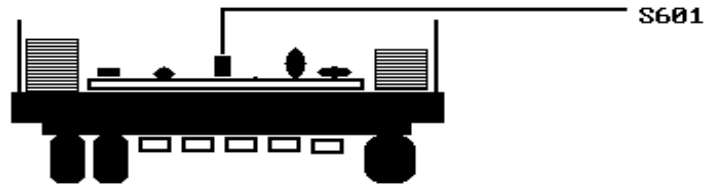

Remove the Jumper

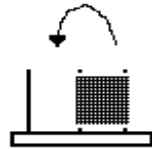

28-29.7 Mhz

And put it on the other 2 pins

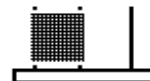

26-32 Mhz

Don't forget to re-program your scanning lower frequency and scanning upper frequency with these new limits otherwise you will not be able to reach the limit frequencies.

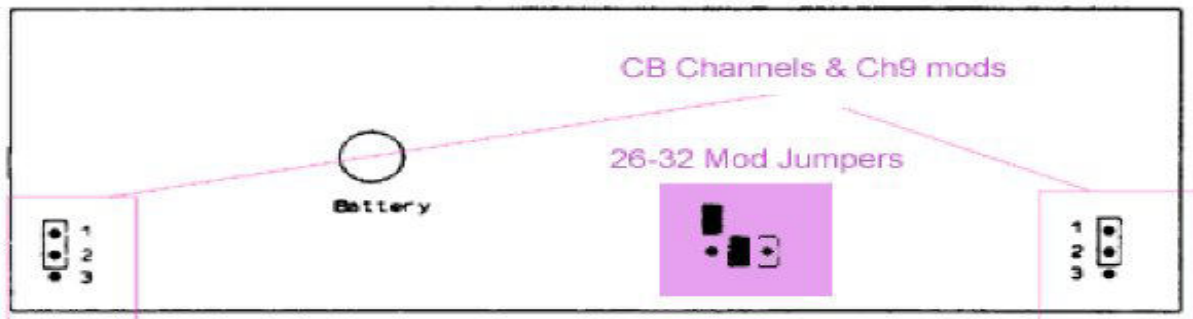

## FREQUENCY MODIFICATION ON NEW VERSIONS

Remove the bottom cover to gain access to the small PC board immediately behind the front panel. There will be a set of jumpers marked "J1" and "J2". Move the jumper from the top two pins to the bottom two pins. Frequency coverage will now be expanded to 26mhz-29.7mhz.

Press the "MAN" button to switch between CB operation and normal operation.

Press the "SHF" button while in CB mode to switch between CB channel readout and frequency readout.

Press the "ENT" button while in CB mode for instand channel 9.

\*NOTE: The battery and the CPU reset have been eliminated in the newer versions, the new system uses memory capacitors for memory backup

IF YOU FILL BOTH PINS J1 AND J2 ON THE NEW VERSION OF THE RANGER 2950 YOU WILL GET 26.000-32.000 JUST LIKE THE OLD VERSION.THE SAME FOR THE 2970. TRY IT IF YOU HAVEN'T YET.

\* \* \* \* \*

### Extra notes

In the early versions, there are two black plugs located near the center of the PC board on the rear of the LCD display. Remove the right-hand plug for coverage down to 26.0000 MHz. The other plug was just hanging on one pin; use it to short the two left-hand pins for coverage from 29.7000 to 32.0000 MHz. If for some reason either or both ranges do not come up, press the white reset button next to the right-hand plug.

For some odd reason, later models were distributed with both plugs missing- possibly to keep some folks from monitoring above 29.7000 MHz- so the radios came ready to operate from 26.0000 to 29.6999 MHz ! For replacement shorting plugs/ obtain Radio Shack #276-1512 (10 count for S1.39}, or equivalents from your local electronic store.

Next, notice the two black shorting plugs on the FAR right-hand and left-hand sides of the same PC board; first, the left plug. You'll notice the plug shorting pins 1 and 2; use the plug to short pins 2 and 3. Press LOCK, which will result in a 40 channel eleven meter readout. Press LOCK again and the frequency of the channel is displayed. Press MAN to revert back to normal VFO. NOTE: frequency LOCK function is lost and SHF (shift) won't work after this change is made; see switch mod following.

Over to the right plug: again, this plug will be shorting pins 1 and 2; use it to short pins 2 and 3. Press R.BEEP to get instant Channel 9. Press R.BEEP again and the frequency of channel 9 will be displayed {27.0650) Press MAN to revert back to VFO status. NOTE the "roger beep" function is lost after this change; see switch mod following.

The above frequency modifications SHOULD NOT BE USED WITHIN THE U.S. except in dire emergencies or for MARS/CAP functions with proper license/permits, although radio hobbyists can MONITOR activities outside the Amateur band such as the range above 29.700 Mhz

### \* Frequency Modification \*

Remove the bottom cover to gain access to the small PC board immediately behind the front panel. There will be a set of jumpers marked "J1" and "J2". Move the jumper from the top two pins to the bottom two pins. Frequency coverage will now be expanded to 26mhz-29.7mhz.

Press the "MAN" button to switch between CB operation and normal operation.  
Press the "SHF" button while in CB mode to switch between CB channel readout and frequency readout. Press the "ENT" button while in CB mode for instand channel 9.

\*NOTE: The battery and the CPU reset have been eliminated in the newer versions, the new system uses memory capacitors for memory backup

## **EXPAND YOUR RCI TO 25 MHZ AND 33 MHZ**

There is a trick to expand your RCI over the factory programmed limits. Yes, I agree that it's not a very clean mod but it works great. So what \_

This trick is to change the X2 crystal ( Quartz ) that is a 10,240 Mhz value one. You can experiment quartz from 9 Mhz to 12 Mhz ( It'll depend on what you have ). This modification will increase the coverage of your RCI from 25 Mhz to 33 Mhz if you make all the quartz switches. Be carefull, the frequency that will be indicated by the LCD screen won't be true of course. You will need a separate frequency counter.

May I suggest unsoldering the original crystal and replace with a mounting slot. It'll then be easier to exchange crystals quickly when needed.

**DO NOT TOUCH TO THE OTHER crystals. It would cause problems.**

[www.radioaficion.com](http://www.radioaficion.com)

## HAM TO CB MODE MODIFICATION

Very often, the RCI is sold as a HAM rig. But it was designed and developed on CB principals. All the experts will tell you that the RCI contains the same components as all major CB TXs. So what ? Is it a CB or a HAM transceiver ?

The short reply is : BOTH. The RCI developing team thought it ham **AND** CB. The microcontroller board has the capabilities of indicating channels or frequencies. The channel mode has just been inactivated by a jumper. Let's get a rid of this limitation.

The jumper is located on the LCD board. On the left side of this board, around the components R626 and RA610, you cannot miss the jumper. Take it off and place it in the other position. You have just activated the channel mode. The " Lock " key will control whether you are in channel mode or in frequency mode.

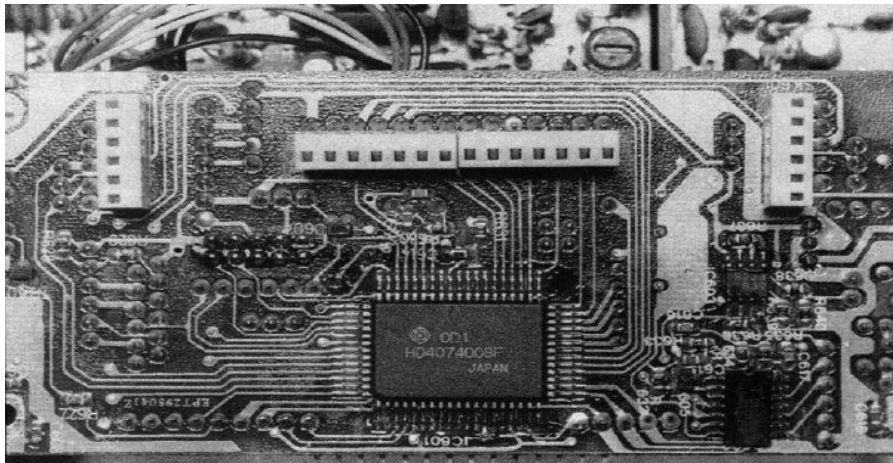

## **A CHANNEL 9 EMERGENCY KEY ?**

Yes, you have one in you RCI. In the same way you modified the previous jumper, you will find a second jumper on the RIGHT side of the LDC board . Take it off and place it in the other position. You have just enabled a channel 9 emergency key. This key is now the old " R-Beep ". Yeah... \_ Who said that the RCI was not a CB rig ?

*Channel 9 Mod*

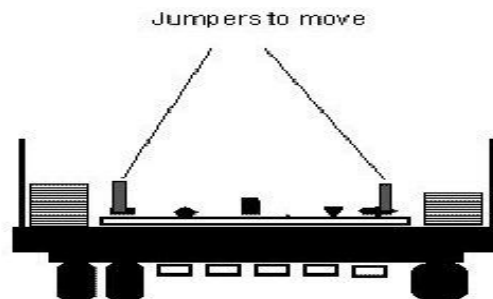

## POWER MODS

**INCREASE YOUR POWER !!!!!**

You can boost your output power in both AM/FM and USB which are driven separately. Have a look at this drawing.

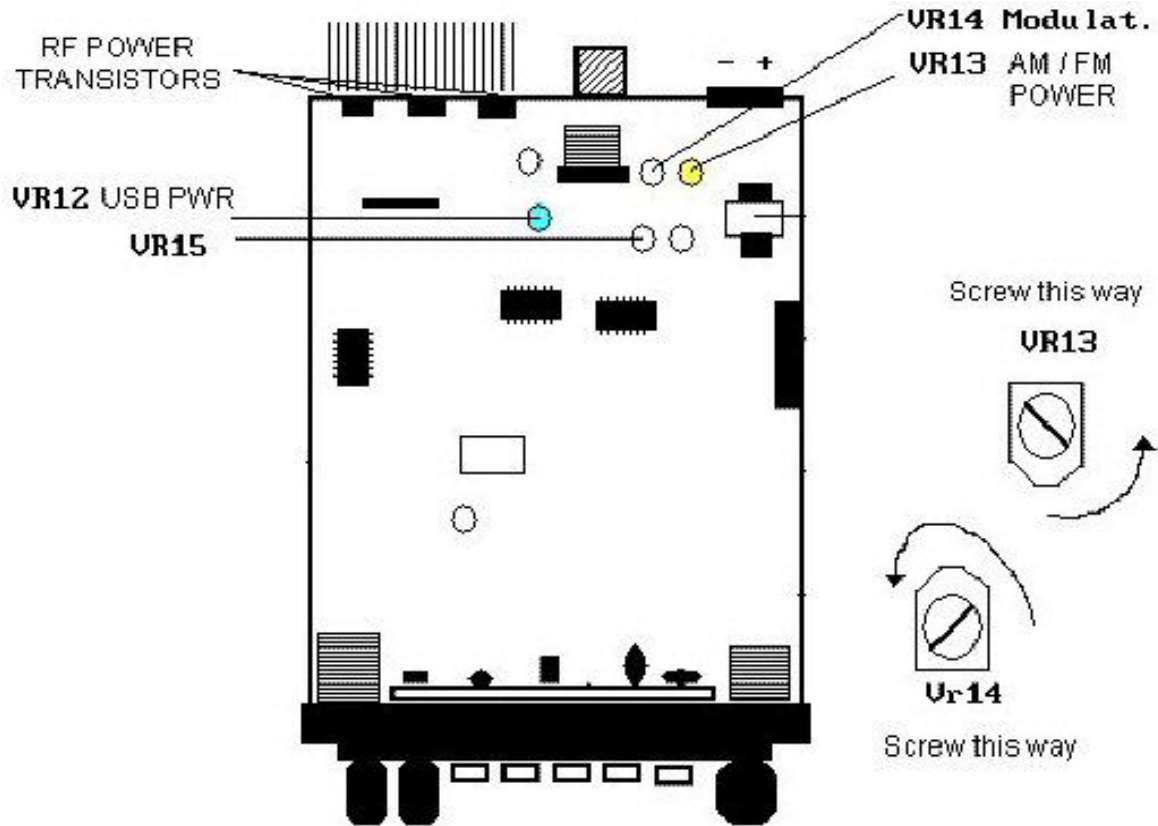

You can go further by replacing the two final transistors. Two 2SC2312 by 2 **MRF477**. Be careful, these two do not have the same wiring. You will have to cross the pins. (A new modification should be replacing the MRF477 by MRF 497 which is more powerful)

Another trick that could be used to boost a bit is to replace **R281** (4,7 K) by a **2,2 K** value and re-adjust VRs for AM and USB. This boosts the power up to 20 watts AM / 30 Watts USB. Be careful this is an extreme mod \_ May be illegal in your country. Check the law beforehand.

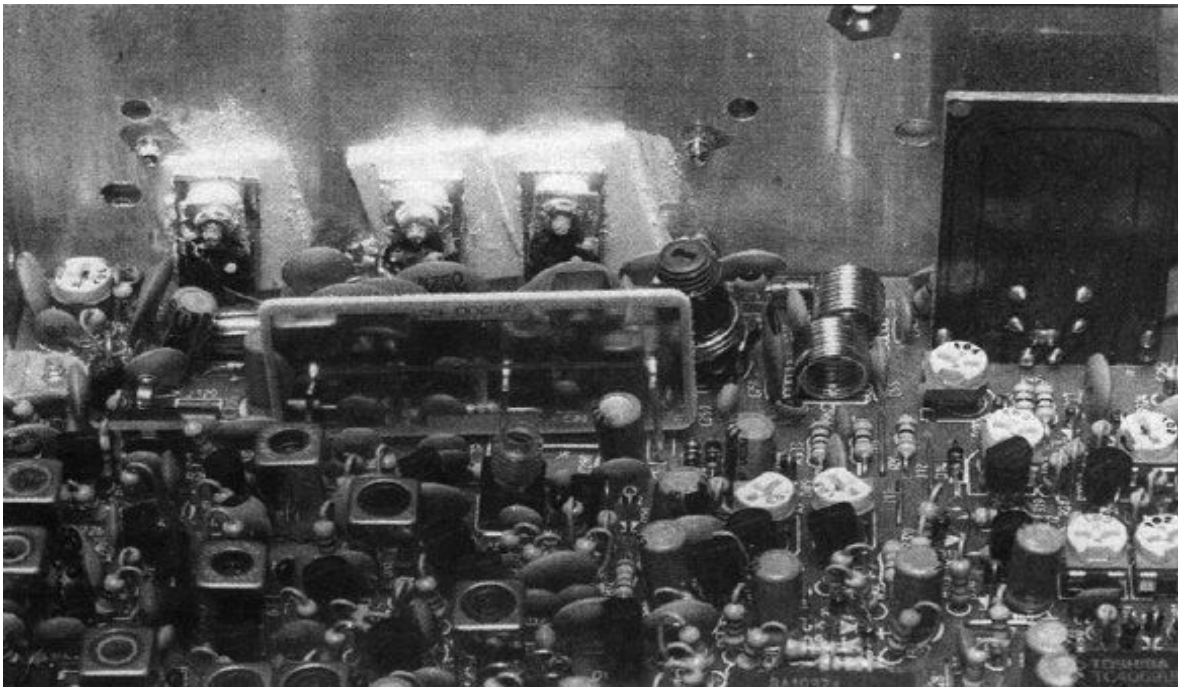

### Differences between 2SC2312 and MRF477

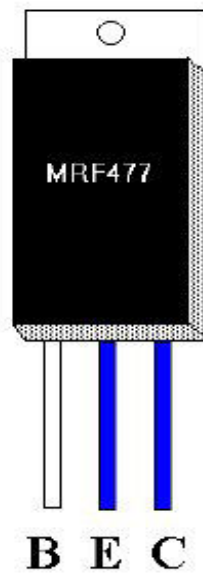
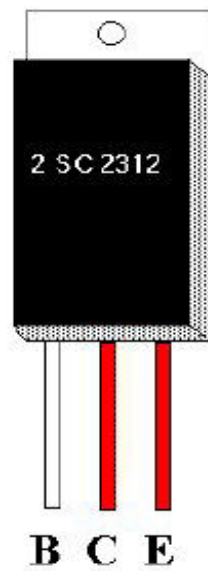

## HEAVY SWINGER MOD

### HEAVY SWINGER MOD (MODULATION)

Locate **Q51** which is a 2SB754. This part should be subbed out with a 2SB688 but doesn't have to be. The 2SB688 is a heavier duty and higher wattage transistor. To do this mod, you will need a 1N914 diode and a 50 ohms resistor. Hook up as drawing shows. This will give you super modulation at whatever power range you want.

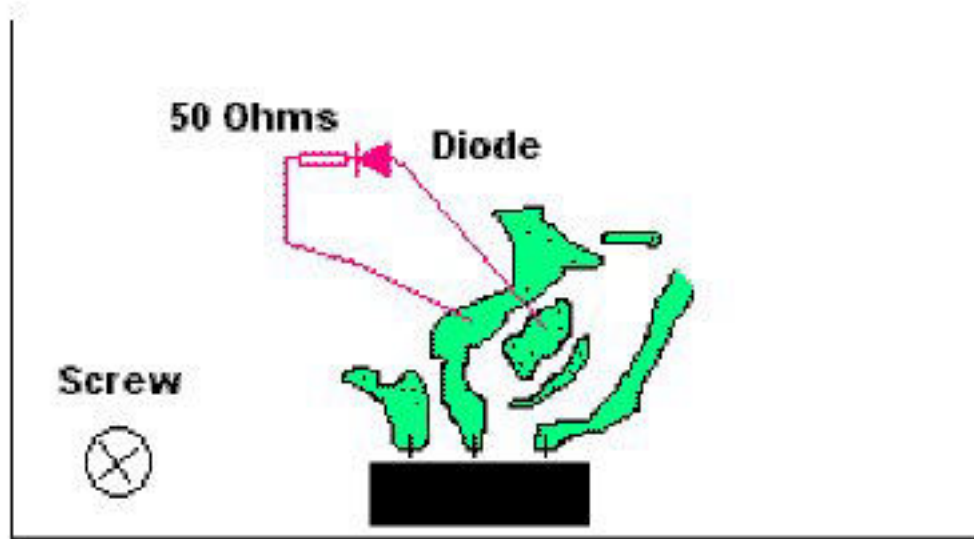

## TUNE-UP

### 2950 TUNE UP/ MOD

To increase heat dissipation and durability and a decrease of transmit voltage drop change **Q-51** to an ECG37 or equiv.

To prevent overheating and increase audio Quality & low pwr swing change **Q53** to a 2SA473

To improve low power swing on AM locate **R178** and change to a 3k ohm. The resistor you just removed save for the next step.(4.7k)

Locate **R194** (10k ohm) replace with the 4.7k resistor from previous step.

Locate **R281** (4.7k ohm) replace with the 10k resistor from the previous step.

For increased output on SSB and AM locate **C270** and parallel with a 470pF-1kv ceramic disc capacitor.

Replace all plastic insulators with mica insulators on all transistors. Use a liberal amount of heat sink compound.

For improved modulation remove **Q32**, which is the modulation limiter.

[www.radioaficion.com](http://www.radioaficion.com)

## UPGRADING AM DETECTION

Change **D34** & **D35** that are 1N60's by ECG583 or SK9975. This mod will enhance the radio performance.

Some version already have 1N60 diodes for d35-d34. The problem that is manifesting itself as AM distortion ( and TX bleed) is caused by the lack of bandwidth control due to the fact of the cheap Xtal filter they use...

I improved the Am on my set by simply putting in a 0.002 Mfd NPO cap at the AM det output diode to ground...This narrows the bandwidth improves the S/NR and cuts some of the high freq audio distortion out and provides smoothing and harmonic reduction from the AM det....

I further improved both the AM and SSB RX (and TX Bleed) by changing the Xtal IF filter... This mod will also increase AGC cut back from sig on other ch and improve S/NR and sen on all bands....

With these mods, realignment and installing a cascade RF RX amp makes the RCI 2950 Rx decent.....

[www.radioaficion.com](http://www.radioaficion.com)

## INCREASE AUDIO

My audio got slightly softer, you have to pull out **tr53** , it is not marked on the board, it is between **vr 12** and **vr 14** . also **r 291** take out!

**This is the modulatuion limiter**

## AUTO SQUELCH

### ADD AN AUTOMATIC SQUELCH TO YOUR RIG

All you need is a VR of 100 K and a **simple switch button**. Follow the diagram's instructions to build this option.

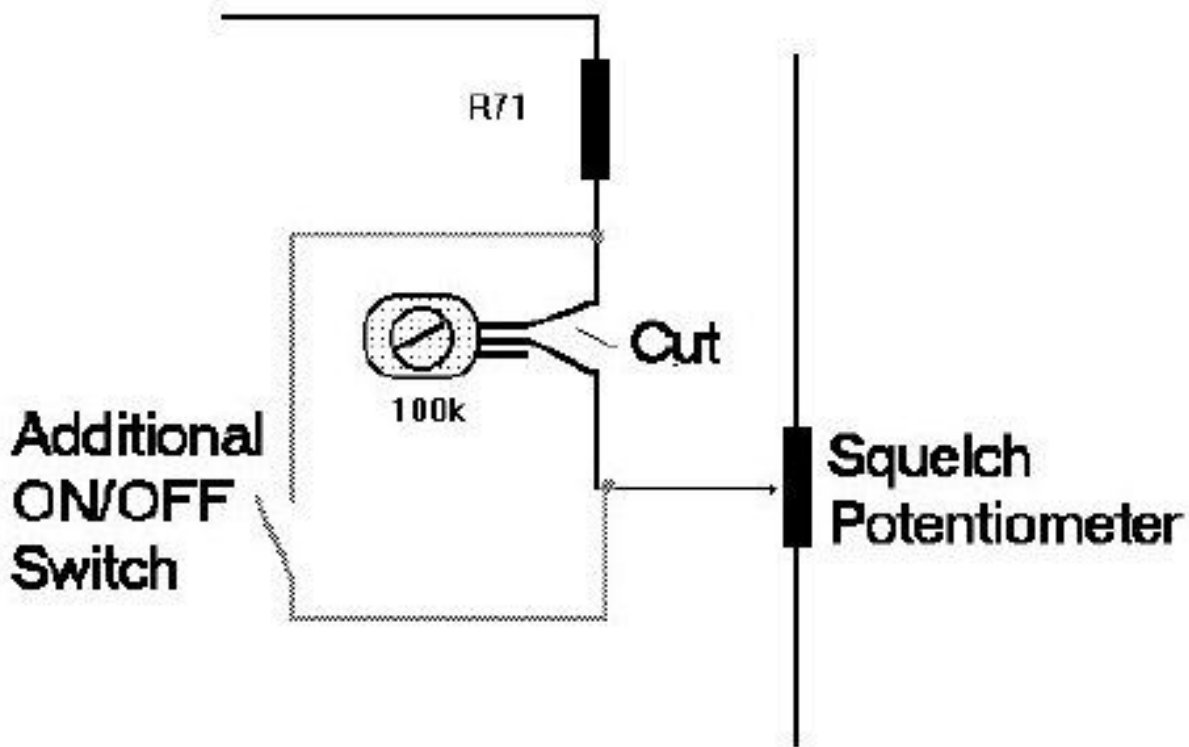

How to setup the AutoSq Option:

- Switch to FM mode
  - Set the Squelch potentiometer to minium
  - Open the additional switch button and adjust VR 100Ko so that the squelch just breaks
- That's all...

## BATTERY PROBLEMS

*Careful: Latest versions of RCI do not have a lithium battery anymore.*

*If you run your 2950 as a base on a power supply the internal 3v battery will drain much faster or if you use it mobile and let the ignition switch turn the radio off and on then the battery will be dead in a very short time. So the next time you open the radio to replace the battery, solder the leads of a 2AA or 2AAA battery holder (either one will equal 3 volts) to the battery contacts (!!! observe correct polarity!!!) Then using a piece of double side tape place the battery holder in an out of the way place. This way when the batteries do go dead you can replace them fast and easily with common batteries.*

### LITHIUM BATTERY UPDATES/ UPGRADES

This seems to have been one sore spot with the 2950. A common replacement is the Ray-O-Vac BR2325TZ-1 Radio Shack's version is listed as #23-d168. If one gets tired of replacing the battery after the warrant runs out, here's a couple of "fixes" for longer battery life and battery elimination!

**a. Battery replacement:** document all memory channels, then remove ALL power from the radio. Remove the covers, knobs and front panel from the radio to allow the display and boards to easily lay forward, allowing easy access to the battery. CAREFULLY remove the lithium battery, noting the correct battery polarities" Next, solder the leads of a 9 volt snap connector (Radio Shack #270-325 or equiv.) to the proper points on the board, red to +, black to -.

Install two "AA" alkaline batteries in a mating holder (Radio Shack #270-382) and snap to the installed 9 volt connector. Carefully swing the display and board assembly back into place and install the four chassis screws. Power the radio up and check all functions. If normal, insulate the batteries and use nylon wire ties to secure them to a wire bundle. Reassemble the radio. Now the memories and functions of the radio should last much longer, and replacements are a "snap"! NOTE; this upgrade has been in use with several radios for over a year with never a failure or replacement!

**b. Battery elimination:** while not tested at this time, the circuit described in this upgrade was adapted from the Realistic HTX-1 00 schematic and should function well with careful assembly. Other memory caps to try would be from Hosfelt Electronics, part #15-343-2 (.1 F 5.5 volts), #90-155 (.22F 5.5 volts) or #15-363 (1.0F 5.5 volts). See the " Sources" section for parts house's addresses.

The above circuit can be built on a small piece of pert board and installed near the rear of the display board. To install:

a. remove the battery

b. tie in the new circuit (5.5 volt output) to where the positive side of where battery was soldered

c. for 13.8 volt input, tie in other end of new circuit to the hot side, or unswitched side of the on/off switch

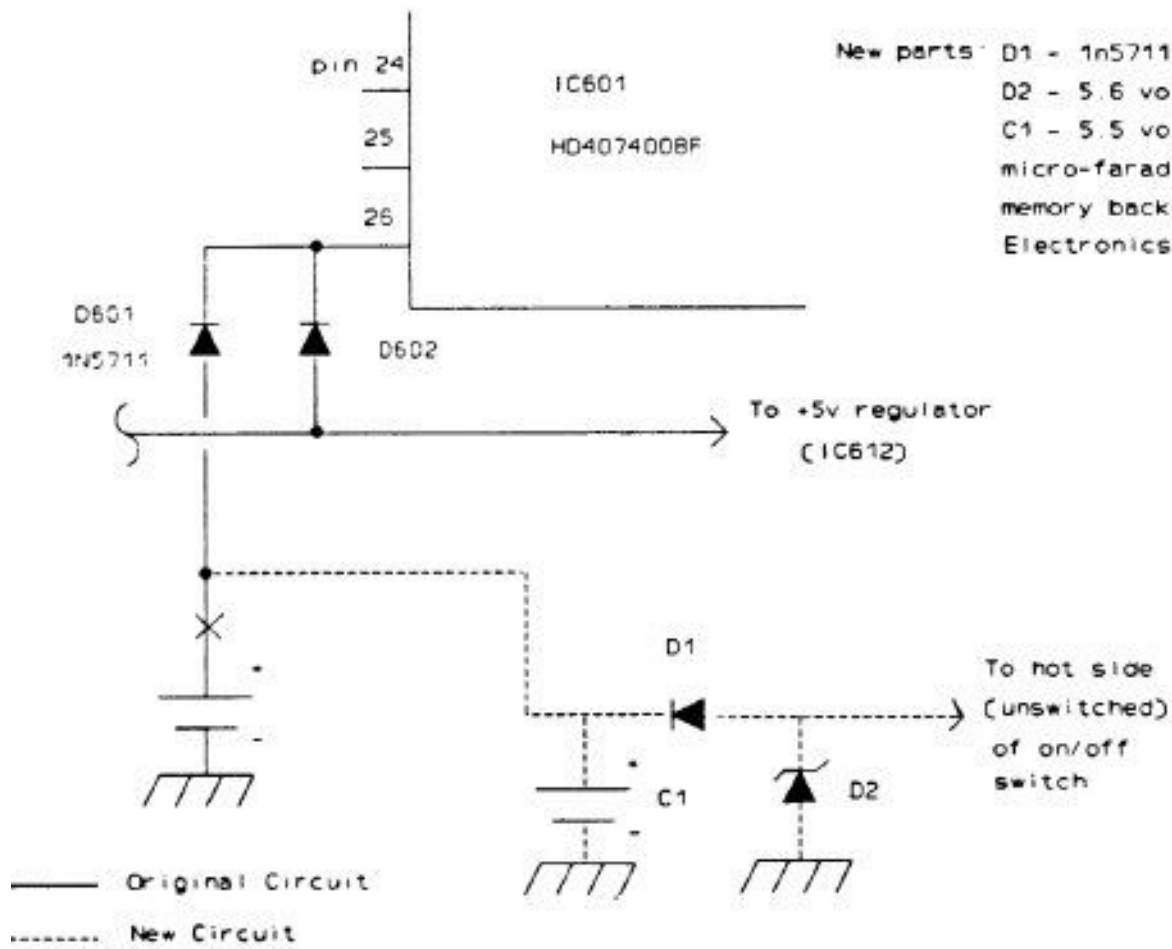

New parts: D1 - 1n5711 (ecg583)  
D2 - 5.6 volt zener  
C1 - 5.5 volt .047  
micro-farad or similar  
memory backup cap (All  
Electronics part # CBC-1)

## CLARIFIER MOD

There is a mod that you did not include that I personally could not do without. The mod is to unlock the clarifier. There is also another mod to prevent distortion from front end overload from very strong signals.

Here is how you do those mods:

When you modify the clarifier it will not track on the display (it will give you about 1.5 Khz shift either way) but you will find it useful in CB mode because the frequency cannot be adjusted. It is also useful when using the rig mobile. You don't have to keep pushing the SHIFT key.

First, locate the wire harness that runs from the clarifier pot to the circuit board. Just in front of where it plugs into the board you will see **R-197** (this resistor usually has wax on it). Clip the top of the resistor. Now get a 6" peice of wire and solder it to the stub of wire sticking out of the board (not to the top of the resistor itself). Connect the other end of the wire to **pin 3 of IC6**, pin 3 is the leg closest to the front of the radio. IC6 is is the 7808A regulator on the mike plug side of the unit case towards the front of the radio. Next locate **D-59**, just to the left of the clarifier harness. It is a 1N4148 diode. Cut the wire part of this diode to disable it. If realignment is necessary use L27 for AM, L28 for LSB and L29 for USB.

That's it.

If you have any problems with close stations being garbled sounding, its because of front-end overload. To reduce it find **R-49** in the middle of the board (100K resistor) Change it to a 33K resistor and it should help. I hope this might be helpful to you.

[www.radioaficion.com](http://www.radioaficion.com)

## INSTALL MY RCI ON THE CAR'S LIGHTER

Prise allume cigare



## ADAPTATION OF STEREO HEADPHONES

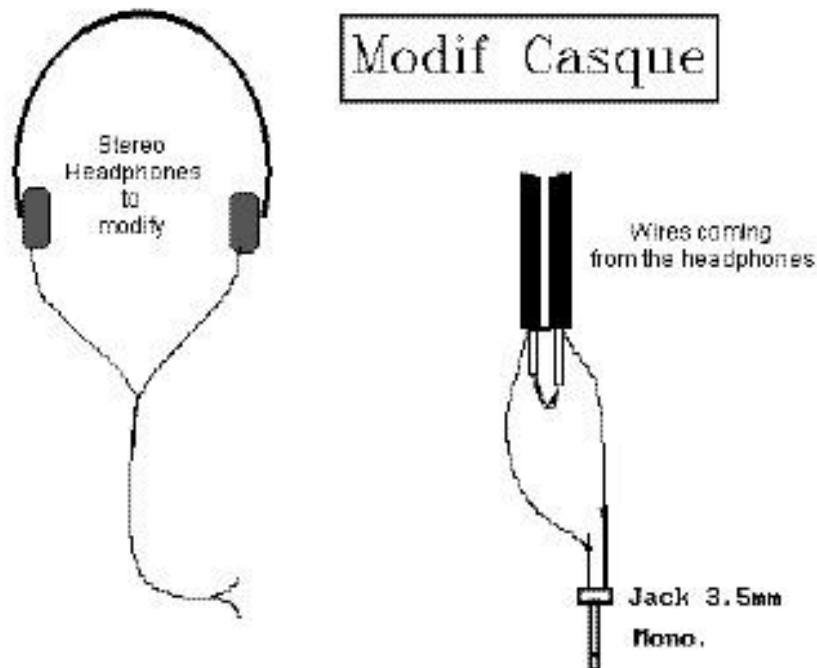



## LCD & LEDS

### THE BACK LITE DISPLAY FOR THE 2950

In this mod. You will remove the filament bulbs and replace them with a low voltage light emitting diode .

Advantages of this mod. Are full control through all four settings of your dim control.

This makes the voltage regulator run cooler for that part of the radio. You can customize the colour of the back light instead of buying those other Slip covers for the filament bulbs .

This mod will also make the light emitting diodes that are under the touch Controls brighter ,as they run off the same supply.

#### The mod

Remove the front part of the radio and the board that has the display too so you can get right at those bulbs.

If you look at the board you will notice a + and - .

This is where the supply is coming from for the old bulbs . Remove the old bulbs . Now get some small wire and make it so you have a + and - at each side of that board .either that you will have to cut traces. What you are trying to do is make the bulbs independent of each other. Anyways back to the mod , so now you have a + and - wire for each new kind of bulb.

Now you will have to select a light emitting diode that runs on less power than the supply on that board puts out. Once you have done this you will have to select a resistor i picked a 10 k at one quarter of a watt .that seemed to match the diodes i used. This will differ each kind of light emitting diode selected .

Dont try to install the lite diodes in the same place as the filament bulbs this will defeat the purpose. When you install the diodes you only need one resistor for each side light emitting diodes are polarized they have a negative and positive hook them up backwards and they do not light up So when you are all done you should have full control on the dim.

If one lite diode blows the other stays going ,this will not happen because of the resistor that is in line on each lite . The power regulator for this supply should run cool no heat better performance i did my personal set one year ago in green lite and it still looks and runs fine .

Pretty simple mod i know it is alot cheaper than buying those little filament Bulbs .i for gotten to tell you light emitting diodes last longer than the Other.

From  
Rick vanluven  
Kingston ontario canada

### DI SPLAY CONTRAST MOD

**First :**

I had a problem with my RCI2950, once in a while the contrast dropped to almost zero. I tried to find the problem and after a while I had the idea that the contrast reference control on the display driver chip was sensitive and instable.

Due to this I came to the decision to put a little more load on the reference input of the display driver.

This was done by soldering a 1 mega ohm resistor to the middle contact of the contrast potentiometer and the display board ground.

In order to make this modification you need too do the following proceder.

Remove the top and bottom cover from your RCI 2950. Carefully remove all the knobs from the front panel, loosen the four counter sunk phillips screws holding the face plate.

Remove face plate.

Loosen the two lowest two phillips screws. (these screws holding the push button circuit board) Remove the push button board extremely carefully by pulling this board in a parallel way toward you. Make sure you pull this board parallel, there are extremely long contacts.

The contrast adjustment trimpot is in the centre of the display board and will be visual if the push button board has being removed.

The trim pot is a SMD (surface mounted) component and resistor should be soldered carefully.

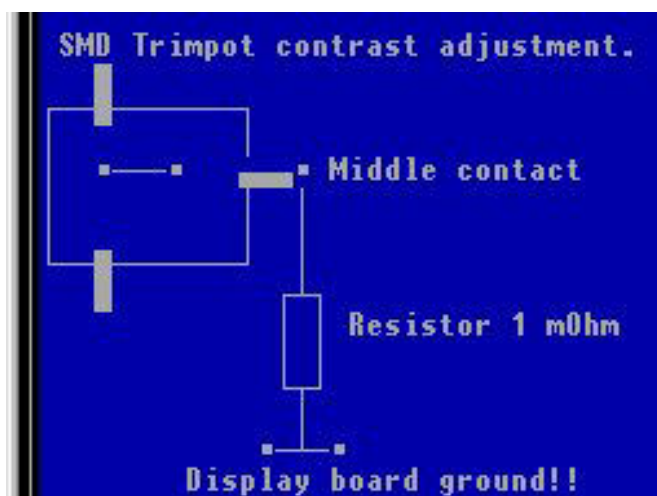

This modification solved my problem for the time being.

## RCI-2950 MI KE Wiring

<p><b>Standart wiring:</b></p> <ol style="list-style-type: none"> <li>1. Ground Shield</li> <li>2. Audio Yellow</li> <li>3. Transmit Red</li> <li>4. Receive Black</li> <li>5. Channel. Up White</li> <li>6. Channel. Down Blue</li> </ol>	<p><b>TURNER 4-WIRE</b></p> <ol style="list-style-type: none"> <li>1. Ground Shield</li> <li>2. Audio White</li> <li>3. Transmit Black</li> <li>4. Receive N/C</li> <li>5. CH. UP N/C</li> <li>6. CH. Down N/C</li> </ol>	<p><b>TURNER 4-WIRE</b></p> <ol style="list-style-type: none"> <li>1. Ground Shield</li> <li>2. Audio White</li> <li>3. Transmit Black</li> <li>4. Receive N/C</li> <li>5. CH. UP N/C</li> <li>6. CH. Down N/C</li> </ol>
<p><b>TURNER 6-WIRE</b></p> <ol style="list-style-type: none"> <li>1. Ground Shield &amp; Red</li> <li>2. Audio White</li> <li>3. Transmit Blue</li> <li>4. Receive N/C</li> <li>5. CH. UP N/C</li> <li>6. CH. Down N/C</li> </ol>	<p><b>ASTATIC 4-WIRE</b></p> <ol style="list-style-type: none"> <li>1. Ground Shield</li> <li>2. Audio White</li> <li>3. Transmit Red</li> <li>4. Receive N/C</li> <li>5. CH. UP N/C</li> <li>6. CH. Down N/C</li> </ol>	<p><b>ASTATIC 6-WIRE</b></p> <ol style="list-style-type: none"> <li>1. Ground Shield &amp; Blue</li> <li>2. Audio White</li> <li>3. Transmit Red</li> <li>4. Receive N/C</li> <li>5. CH. UP N/C</li> <li>6. CH. Down N/C</li> </ol>
<p><b>Sadelta:</b></p> <ol style="list-style-type: none"> <li>1-Shield</li> <li>2-White</li> <li>3-Brown</li> <li>4-Green</li> <li>5-N/C</li> <li>6-N/C</li> </ol>		

## PROTECT YOUR MOBILE RIG FROM POLARITY INVERSIONS

Yes you can ! This mod will let you reverse polarity on your set with no risks at all. Even more, it'll work as if nothing had happened. I'm sure some of you are going to bet with their friends. I did \_

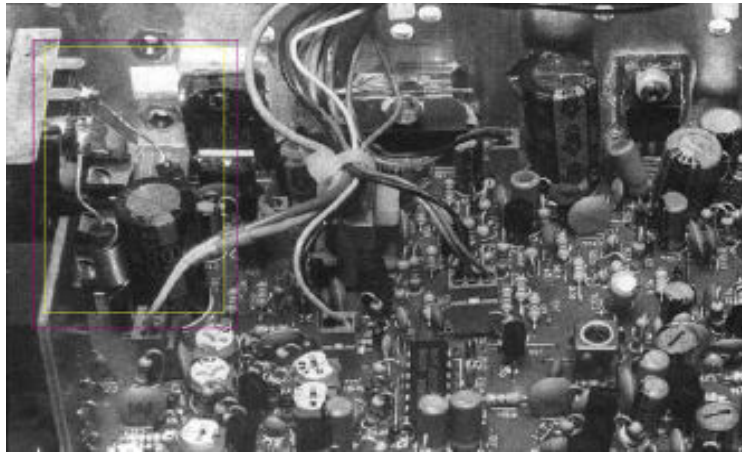

All you need ( is love ) is 4 diodes of the series 1N400x ( 1N4003 for instance). Insert them in the 12,5 V DC line as shown in the drawing. That `s all. Have fun and kick away one of the most frequent problem of troubleshooting in CB.

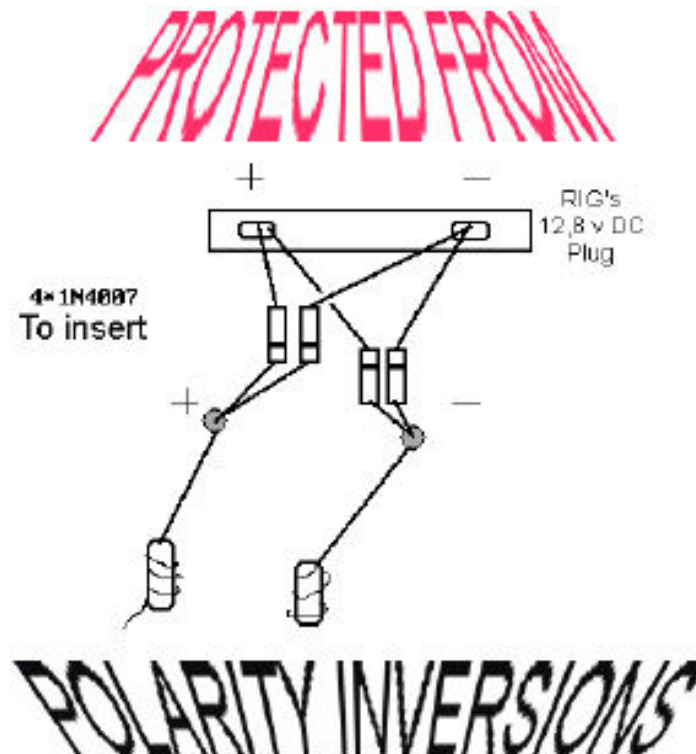

## MOD FOR FASTER SCAN SPEED ...

First take the radio's top and bottom covers off then remove all the dials off the front face plate then take out the screws that hold the front face plate. Now you're looking at the lcd and button printed circuit board, remove the lcd printed circuit board. Now you should see the main processor board. Lay the radio so that the solder side of the big main board is solder side down so that you can see the components. Now look at the board that has the processor on it. If you look at the back side of the board (processor board) where the battery goes you should see a blue rectangular shaped resonator marked 2.00g or 2.000 or 2000 kc that also would have a x1 or x2 etc number on the board near it that is also listed in the service manual as a resonator/crystal.

If you change the value of this part (remove it and replace it with a crystal ) with a value of 8mhz will make the processor run faster in turn giving you faster up/down on your mic, faster scan speed, faster memory scan, a shorter roger beep sounds like or similar to 2510. Myself when I experimented with my own radio I ran into trouble when I used a crystal with a value of 14mhz

- 14mhz (works but locks up the radio from time to time)
- 12mhz (was pretty much the same but didn't lock it up as much)
- 10mhz (worked fine but I wanted to run with 8mhz just to make sure)(the radio worked good in all mods all the time)
- 8mhz (would be what I would recommend not as fast as the others but is a lot more stable for daily usage and is a lot faster than stock)

### CAUTION:

BE SURE WHEN DOING THIS MOD YOU ARE CAREFUL NOT TO DAMAGE THE CIRCUIT BOARD AS MOST OF IT IS SURFACE MOUNT THE TRACES DAMAGE VERY EASILY

THE RESONATOR IS STANDARD SIZE OF A CRYSTAL REMOVE THE RESONATOR AND REPLACE IT WITH A CRYSTAL WITH WIRE LEADS NOT THE STANDARD PLUG IN TYPE AS THEY WON'T FIT

My method of desoldering the resonator was with a solder sucker with a heated tip.

Where to get crystals? old pc/xt/at motherboards from computers otherwise you will pay about \$10cdn for them.

To assemble radio just do the reverse of the disassembly

I found a two lead 9.6Mhz crystal that does work. The problem I found with this mod is that when I turn the 2950 off, then on, it resets the memory which is very annoying. What I did to resolve this was to wire both the 4Mhz and the 9.6Mhz at the same time. I put a SPST switch in the circuit for the 4Mhz (original component). When I switch the 4Mhz out of the circuit, the Scan is faster. When I switch the 4Mhz back into the circuit, it slows the scan back to original, and makes the rig shut off correctly and turn back on with all the memory intact.

## EXTERNAL S-METER

The RCI does not have any external plug to use a S-Meter. With this mod, you can add one. If you compare most of the base rig which have this option, you can see that everything is around VR1 & VR2 squelch components.

The signal you need to catch for the external meter is present on the cathode of the diode D14. All you have to do is to add a female jack 3,5 plug to the back of the rig. You will put a wire from **D14 cathode** to the central pole of the jack plug.

### External S-Meter Option

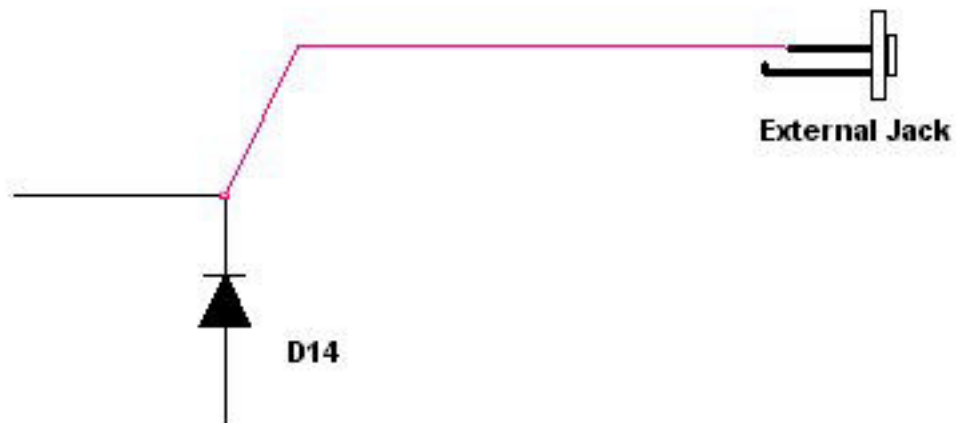

## TALK BACK MODIFICATION

- Well here go's The talk back is done by clipping one end of D-78. or you can wire a spdt switch to switch on and off!
- A common way to obtain talk-back on the 2950 is to lift one leg of the diode marked D-78. Many times, a switch is installed to create a switchable talk-back. This is probably not the only way to enable the talk-back feature, but it's an easy way. To disable the talk-back, make sure there's a 1N914 type diode in the D-78 position. If that doesn't work, trace the D-78 circuit to make sure nobody performed the mod by cutting a trace on the solder side of the board. To locate D-78, remove the covers. Orient the radio with the speaker side up, and the display facing you. In the upper right quadrant, you'll see IC-14 (the audio IC) mounted to the chassis. You'll also see T-1 to the left of IC-14. D-78 is toward the front of the radio a bit from T-1. I hope this helps and good luck..
- The removal of D-78 will indeed provide a talk-back, but it will be very scratchy and distorted. Try it this way instead:
  1. Cut D-78 . Wire a SPST switch in series with D-78 to make it switchable.
  2. Replace D-115 with a .0047uF disc cap.

You will now have a clear and natural sounding talkback guaranteed to make you smile!

[www.radioaficion.com](http://www.radioaficion.com)

## tone modification

You need to listen with confort ? Add a tone capability to your RCI. Very simple.

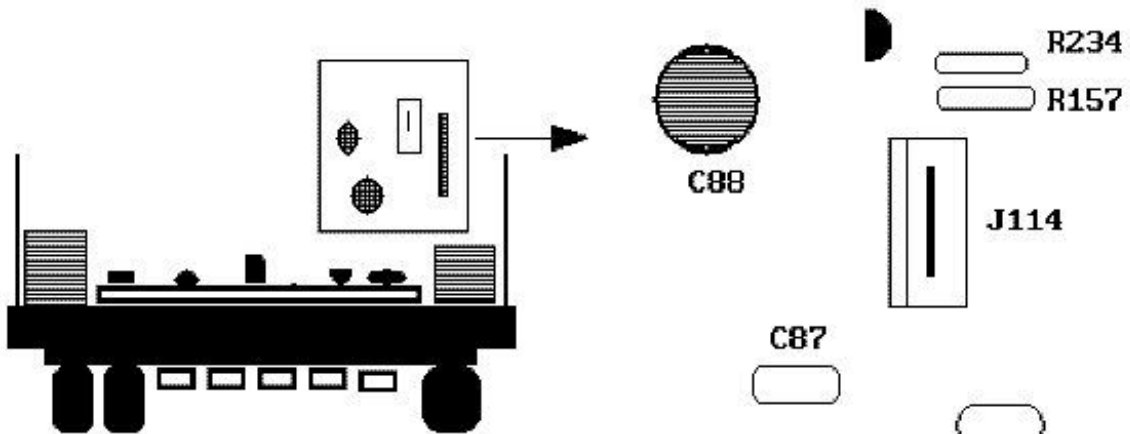

You may cut **J114** & insert a switch

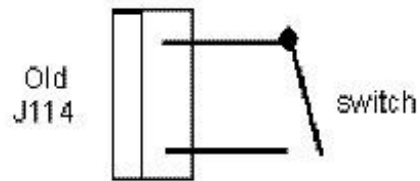

## RCI 2950 TX Alignment [TX Alignment Locations](#)

SETTINGS	CONNECTION	ADJUST	ADJUST FOR
<b>Remove TP1, TP2, TP3 Jumper PCB.</b>			
<b>DRIVER BIAS:</b> Set mode to LSB Mic Gain to minimum	Connect DC Ammeter between TP9 and TP8.	<b>VR11</b>	In TX adjust for 50-75mA.
<b>FINAL BIAS:</b> Set mode to LSB Mic Gain to minimum	Connect DC Ammeter between TP9 and TP7.	<b>N/A</b>	In TX check for 160-180mA.
<b>Replace TP1, TP2, TP3 Jumper PCB.</b>			
Mode LSB Frequency to 28.000MHz Adjust VR14 fully counterclockwise. Adjust VR12 fully counterclockwise. Set generator for 30mV RMS, 1KHz sinewave.	Connect an audio generator to (pin 2) and ground (pin 1) of Mic connector. Connect a wattmeter and 50ohm dummy load to the antenna connector. Set wattmeter for 30W scale.	<b>Mic Gain</b>	Key the transmitter and slowly increase Mic Gain until you obtain about 10W.
		<b>L19, L48 L47, L46, L43, VC3</b>	Adjust for maximum reading on wattmeter. Reduce RF gain if necessary to maintain about 10 to 15W on wattmeter.
Increase Mic gain to maximum (fully clockwise).	Same as above.	<b>L34</b>	Adjust for maximum output power
<b>SSB CARRIER BALANCE:</b> Set mode to USB MIKE GAIN to minimum.	Same as above.	<b>VR7</b>	Key TX; adjust for minimum carrier on scope or wattmeter. If necessary readjust for best balance of sideband suppression between LSB & USB
<b>SSB HIGH PWR:</b> With Mic gain still a maximum on LSB Set RF PWR control on radio to minimum.	Same as above.	<b>VR12</b>	Key the transmitter and adjust for 28W.
<b>SSB LOW PWR:</b> With Mic gain still a maximum on LSB Set RF PWR control on radio to minimum.	Same as above.	<b>VR16</b>	Key the transmitter and adjust for 10W.
<b>AM POWER HIGH:</b> Set RF PWR control on radio to maximum Put mode selector on AM. Mic Gain to minimum	Connect a wattmeter and 50ohm dummy load to the antenna connector. Set wattmeter for 30W scale.	<b>VR13</b>	Key transmitter with no modulation applied and adjust for 10W.
<b>AM POWER LOW:</b> Set RF PWR control on radio to minimum. Mic Gain to minimum	Connect a wattmeter and 50ohm dummy load to the antenna connector. Set wattmeter for 30W scale.	<b>VR15</b>	Key transmitter with no modulation applied and adjust for 2W.
<b>RF METER:</b> Set RF PWR control on radio to maximum. Mic Gain to minimum.	Connect a wattmeter and 50ohm dummy load to the antenna connector. Set wattmeter for 30W scale.	<b>VR8</b>	Adjust so panel meter agrees with Wattmeter.
<b>AMC:</b> Mode to AM Set generator for 30mV RMS, 1KHz sinewave. With Mic gain at maximum	Same as above.	<b>VR14</b>	Adjust for 100% modulation. Use modulation meter or oscilloscope with RF sampler.
<b>FM DEVIATION:</b> Put mode selector on FM	Key transmitter and check for 4kHz deviation $\pm 0.5$ kHz. Use deviation meter or service monitor.	<b>N/A</b>	Simply check for sufficient transmit audio. <b>There is no deviation adjustment provided in this radio.</b>

# Ranger RCI-2950

## Alignment Locations TX

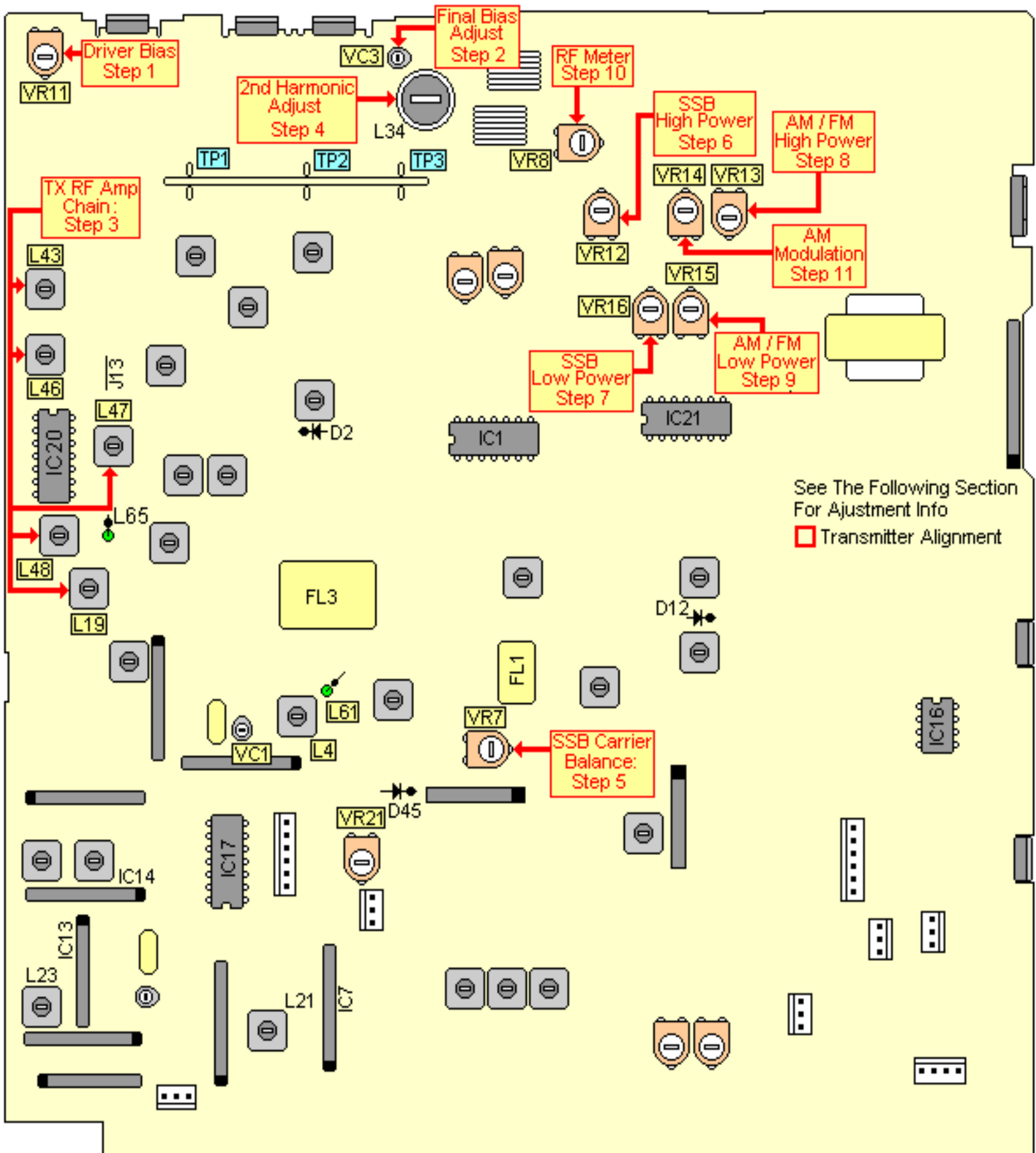

## RCI 2950 RX Alignment

### [RX Alignment Locations](#)

SETTINGS	CONNECTION	ADJUST	ADJUST FOR
<b>AM/FM RF &amp; IF SENSITIVITY:</b> Put mode selector on FM, RF gain fully clockwise, Clarifier at 12 o'clock, frequency at 28.0300 MHz.	Connect an FM signal generator to the antenna connector. Set modulation for $\pm 3$ kHz, output level at 0.5uV. Connect a SINAD meter to the external speaker jack, volume control at about 10 o'clock. Connect an oscilloscope with a X10 probe to the <b>Cathode of D12</b> . Set sweep selector for 1uS per division and vertical input selector for 10mV per division.	<b>L8</b>	Adjust for best SINAD reading and least distorted waveform on scope. Do not try tuning this coil for maximum, as this will result in degraded receiver performance.
		<b>L9, L11 L12, L13 L14, L4 L3, L5 and L6</b>	Adjust for maximum on scope. Reduce generator level if necessary, so as not to exceed vertical height on scope.
		<b>L5 L6</b>	Adjust for best SINAD
<b>FM DETECTOR:</b> Mode FM. Set FM RF Generator to 26.965 MHz 0.5uV deviated 3 KHz with 1KHz audio tone. Reduce VOLUME as required.		<b>L7</b>	Adjust for maximum audio output.
<b>SSB IF SENSITIVITY:</b> Put mode selector on LSB.	Signal generator to 28.0290 MHz, modulation off, output level at .5uV. Adjust Clarifier for best SINAD reading. Connect oscilloscope same as above.	<b>L15 L16</b>	Adjust for maximum on scope.
<b>SSB S-METER:</b> Set mode to USB. Increase RF Generator output to 26.966 MHz 100uV (-67 dBm) unmodulated. Set Squelch fully counterclockwise.	RF Generator to ANT Jack	<b>VR2</b>	Adjust for "S-9" meter reading.
<b>AM/FM S-METER:</b> Set mode to AM. RF Generator output to 100uV unmodulated. Set Squelch fully counterclockwise.	Same as above	<b>VR1</b>	Adjust for "S-9" meter reading.
<b>AM/FM SQUELCH RANGE:</b> Increase RF Generator output to 10mV. Set Squelch Control fully clockwise.	Same as above	<b>VR3</b>	Adjust to the squelch just closes.
<b>SSB SQUELCH RANGE:</b> Set mode to USB.	Same as above	<b>VR4</b>	Adjust to the squelch just closes.
<b>NOISE BLANKER:</b> Set radio to 26.975MHz Set mode to AM. Set RF generator output to 26.965MHz at 1000uV unmodulated. Set NOISE BLANKER switch to "ON".	Connect DC Voltmeter to TP1 ( <b>Cathode of D2</b> )	<b>L1, L2</b>	Adjust for maximum DC voltage.

# Ranger RCI-2950

## Alignment Locations RX

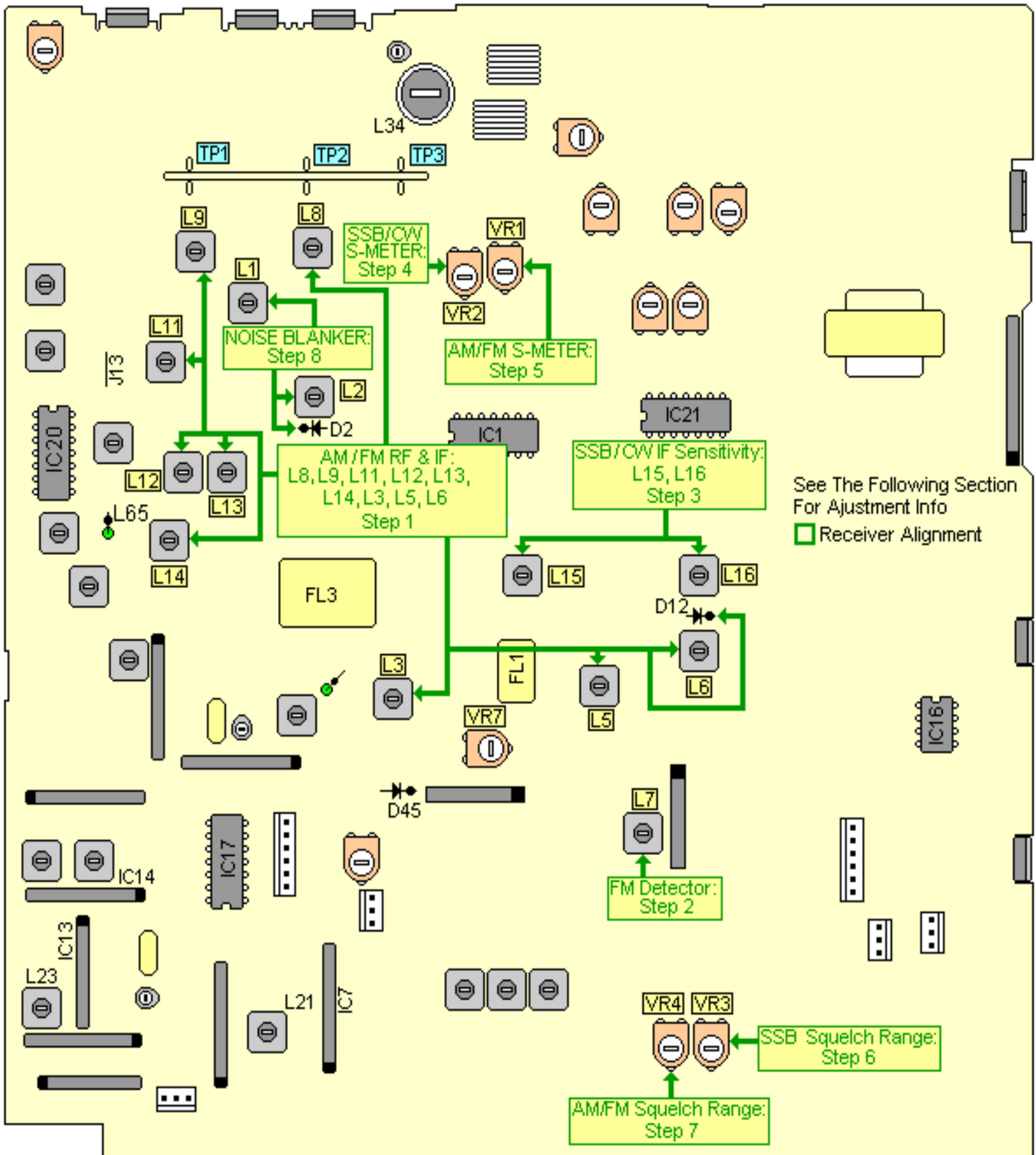

## Ranger RCI-2950 PLL Alignment

### [PLL Alignment Locations](#)

SETTINGS	CONNECTION	ADJUST	ADJUST FOR
<b>Remove TP1, TP2, TP3 Jumper PCB.</b>			
<b>VCO &amp; OSC:</b> Frequency: 28.0000 MHz MIC Gain: Fully counter-clockwise RF Power: Fully clockwise RF Gain: Fully clockwise Clarifier: 12 o'clock Vol : Comfortable level Squelch: Fully counter-clockwise Mode selector - AM	Disconnect shorting board from test points TP1, TP2 and TP3		
	Connect Freq. Counter to L61	<b>VC1</b>	Adjust for reading of 10.240MHz ± 10Hz.
	Connect Oscilloscope to L61	<b>L4</b>	Adjust for Max.
	Connect a Freq. Counter to L65	<b>VC2</b>	Adjust for 17.305MHz ±10Hz.
	Connect a Freq. Counter to L65	<b>VR21</b>	Key Transmitter and adjust for 17.305MHz ±10Hz.
	Connect Voltmeter to IC7 Pin3	<b>L21</b>	Adjust for 1.2VDC ±.1VDC.
	Connect Voltmeter to J13	<b>L17</b>	Adjust for 2.0VDC ±.1VDC.
	Connect Oscilloscope to L65	<b>L19</b>	Adjust for Max.
Connect Freq. Counter to IC13 pin8	<b>L23</b>	Very carefully adjust for 11.350MHz ±10Hz.	
Connect Oscilloscope to IC17 pin13	<b>L24</b> <b>L25</b>	Very carefully adjust and for best waveform	
<b>AM TX OSC:</b> Same as above	Connect a frequency counter to cathode of D45	<b>L27</b>	Key transmitter and adjust for 10.6950 MHz ±10Hz.
<b>USB TX OSC:</b> Adjust VR7 fully clockwise. Put mode selector on USB.	Leave frequency counter connected to D45	<b>L29</b>	Key transmitter and adjust for 10.6925 MHz ±10Hz.
<b>LSB TX OSC:</b> Put mode selector in LSB. After adjustment return VR7 to approximate middle of rotation.	Leave frequency counter connected to D45	<b>L28</b>	Key transmitter and adjust for 10.6975 MHz ±10Hz.
<b>Replace TP1, TP2, TP3 Jumper PCB.</b>			

# Ranger RCI-2950

## Alignment Locations PLL

