

OPERATING AND MAINTENANCE MANUAL

**Model 150-A/B
100 W 8 Channel SSB Transceiver**



CONTENTS

SECTION I - GENERAL INFORMATION		SECTION VI - MAINTENANCE	
UNPACKING	3	GENERAL	14
DESCRIPTION	3	TEST EQUIPMENT	14
SPECIFICATIONS	3	CHASSIS CABLING	14
FRONT PANEL CONTROLS AND CONNECTIONS	3	INTERNAL ADJUSTMENTS - RECEIVER	
REAR PANEL CONNECTIONS	4	12.7 MHZ I-F TRAPS	14
INDICATORS	4	I-F AMPLIFIER	14
SECTION II - INSTALLATION		NOISE BLANKER	14
GENERAL	4	S-METER CALIBRATION	18
FIXED STATION INTERCONNECTIONS	4	CARRIER OSCILLATOR	18
POWER CONNECTIONS	4	INTERNAL ADJUSTMENTS - TRANSMITTER	
ANTENNA CONNECTIONS	5	POWER AMPLIFIER BIAS	18
CHANNEL SWITCH CONNECTIONS	5	BALANCED MODULATOR	18
MICROPHONE CONNECTIONS	5	CARRIER BALANCE	18
LINEAR AMPLIFIER CONNECTIONS	5	SWR BRIDGE	18
TELEPHONE INTERFACE	5	LED ADJUSTMENT	18
MOBILE STATION INTERCONNECTIONS		POWER OUTPUT ADJUSTMENT	18
POWER CONNECTIONS	6	CARRIER LEVEL IN TUNE MODE	19
ANTENNA CONNECTIONS	6	SWR CALIBRATION	19
SECTION III - OPERATION		MICROPHONE AMPLIFIER ADJUSTMENTS	19
GENERAL	6	VOX/CW ADJUSTMENTS	
POWER ON/OFF	6	MIC. GAIN	19
CHANNEL SELECTOR	6	DELAY	19
USB/LSB SWITCH	6	ANTI	19
RECEIVING		800 HZ PEAK	19
VOLUME	7	MONITOR	19
SQUELCH/OFF	7	CW LEVEL	19
CLARIFIER	7	CHANNEL CRYSTAL CALIBRATION	19
NB-OFF Switch	7	LOCATING FAULTY CIRCUITS	20
PHONES Jack	7	REPLACING PC ASSEMBLIES	20
METER	7	PC ASSEMBLY REPAIR	20
TRANSMITTING		FUNCTION TABLE	21
PTT-VOX/CW Switch	7	SCHEMATICS	
CW Operation	7	BAND SWITCH	22
CARRIER Switch	7	XTAL OSCILLATOR	22
METER	8	TX-RX MIXER	23
OPERATING HINTS	8	SSB	23
IF YOU HAVE TROUBLE	8	CARRIER OSC.	24
SECTION IV - INSTALLING CRYSTALS AND OPTIONS		LOW LEVEL AMP.	24
GENERAL	9	RF POWER AMPLIFIER	25
PROGRAMMING	9	LOW PASS FILTERS	25
CRYSTAL SPECIFICATIONS	9	IF/AF	26
CRYSTAL INSTALLATION	10	TOGGLE SWITCH	26
OSCILLATOR CALIBRATION	10	DISTRIBUTION BOARD	26
UPPER AND LOWER SIDEBAND FILTERS	10	NB Option	27
INSTALLING NOISE BLANKER	11	VOX Option	27
SECTION V - CIRCUIT DESCRIPTION		SEMICONDUCTOR TERMINATIONS	28
GENERAL	12	SPECIAL PARTS LISTING	28
RECEIVER CIRCUITS	12	MODEL 700-C HANDHELD MICROPHONE	Insert
TRANSMITTER CIRCUITS	13	LIST OF ILLUSTRATIONS	
CONTROL CIRCUITS	13	Figure 1 - Model 150-A	2
SECTION VI - MAINTENANCE		Figure 2 - AMP MATE-N-LDC Connector	5
GENERAL	14	Figure 3 - BAND SWITCH Assembly Printing	9
TEST EQUIPMENT	14	Figure 4 - XTAL OSCILLATOR Printing	10
CHASSIS CABLING	14	Figure 5 - SSB Assembly Printing	10
INTERNAL ADJUSTMENTS - RECEIVER		Figure 6 - PC Board Mounting	11
12.7 MHZ I-F TRAPS	14	Figure 7 - Block Diagram	12
I-F AMPLIFIER	14	Figure 8 - Cable Wiring Diagram	15
NOISE BLANKER	14	Figure 9 - Inside Top View	16
S-METER CALIBRATION	18	Figure 10 - Inside Bottom View	17
CARRIER OSCILLATOR	18	Figure 11 - Semiconductor Terminations	28
INTERNAL ADJUSTMENTS - TRANSMITTER			
POWER AMPLIFIER BIAS	18		
BALANCED MODULATOR	18		
CARRIER BALANCE	18		
SWR BRIDGE	18		
LED ADJUSTMENT	18		
POWER OUTPUT ADJUSTMENT	18		
CARRIER LEVEL IN TUNE MODE	19		
SWR CALIBRATION	19		
MICROPHONE AMPLIFIER ADJUSTMENTS	19		
VOX/CW ADJUSTMENTS			
MIC. GAIN	19		
DELAY	19		
ANTI	19		
800 HZ PEAK	19		
MONITOR	19		
CW LEVEL	19		
CHANNEL CRYSTAL CALIBRATION	19		
LOCATING FAULTY CIRCUITS	20		
REPLACING PC ASSEMBLIES	20		
PC ASSEMBLY REPAIR	20		
FUNCTION TABLE	21		
SECTION III - OPERATION			
GENERAL	6		
POWER ON/OFF	6		
CHANNEL SELECTOR	6		
USB/LSB SWITCH	6		
RECEIVING			
VOLUME	7		
SQUELCH/OFF	7		
CLARIFIER	7		
NB-OFF Switch	7		
PHONES Jack	7		
METER	7		
TRANSMITTING			
PTT-VOX/CW Switch	7		
CW Operation	7		
CARRIER Switch	7		
METER	8		
OPERATING HINTS	8		
IF YOU HAVE TROUBLE	8		

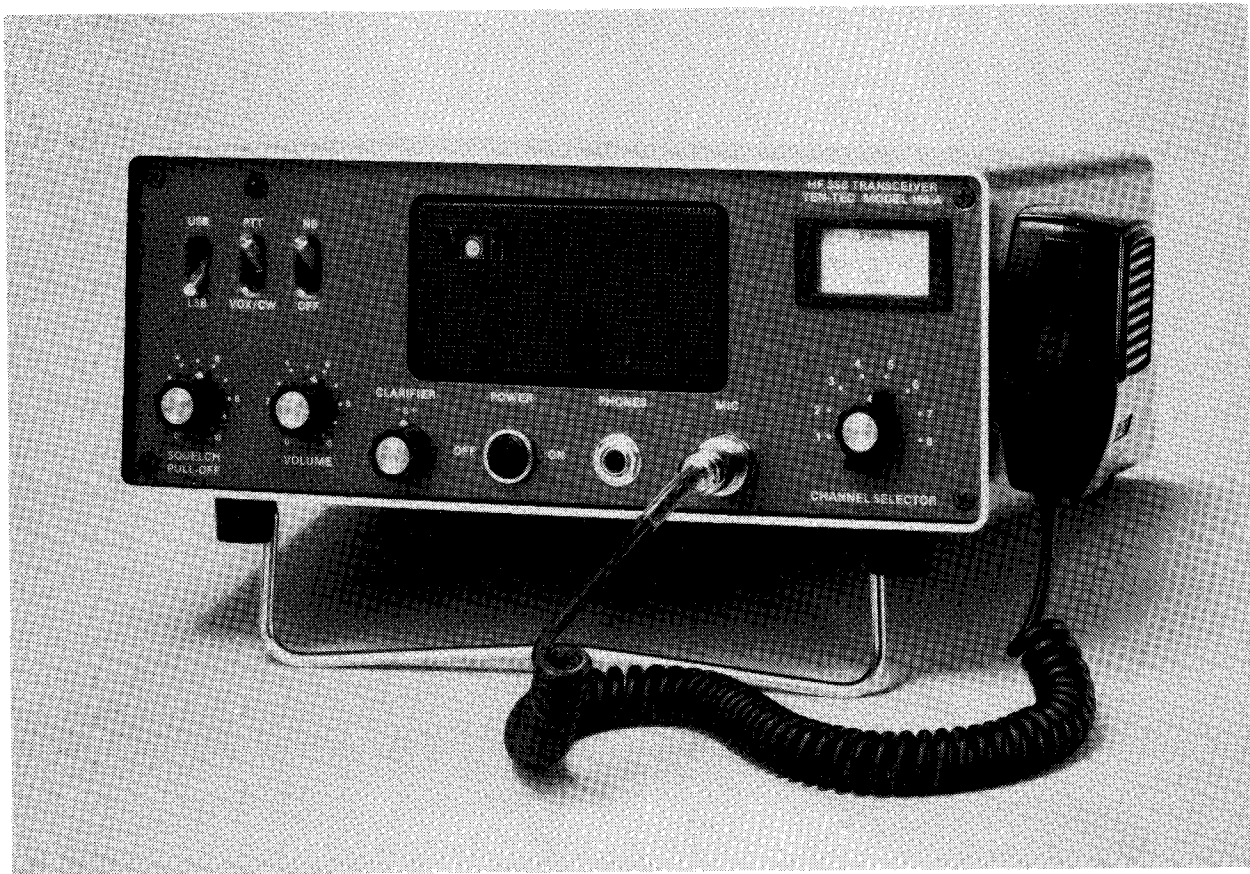

Figure 1 - Model 150-A

SECTION I

GENERAL INFORMATION

UNPACKING

Carefully remove the Model 150 from the packing carton and examine it for signs of shipping damage. Should any be apparent, notify the delivering carrier immediately, stating the full extent of the damage. Retain all damaged cartons. Liability for damage rests with the carrier.

It is recommended that you keep the shipping carton and fillers. In the event that storage, moving or reshipment becomes necessary, they come in handy. Accessory hardware, etc. are packed with the transceiver. Make sure that you have not overlooked anything.

DESCRIPTION

The TEN-TEC Model 150 Transceiver is a medium power single sideband hf transceiver employing the latest techniques in solid state technology. Two basic models provide up to eight crystal controlled channels, with 100 watts PEP output, between 2 and 12 MHz. The basic 13 volt dc circuit is ideal for portable or mobile operation and as a base station with optional power converter. Broadband circuits reduce operator transmitter and receiver adjustments to a minimum.

Model 150-A provides full coverage between 2 and 12 MHz in four bands: 2 to 3, 3 to 5, 5 to 8 and 8 to 12 MHz. Any channel may be operated on any frequency within the range without alteration or additional components. A simply constructed programming cable determines the channel/band configuration. Model 150-B is a single band transceiver providing all eight channels within any one band. Both models can be supplied with either upper or lower sideband operation, or with both as an option. Also, they are available with eight single frequency simplex channels (standard) or with any combination of single or two frequency simplex (semi-duplex) channels, employing up to eight total crystals, at additional cost. An effective noise blanker and VOX/CW operation are available as options.

Because of the low voltage solid state design, with its corresponding low operating temperature, Model 150 will provide you with a very dependable means of communication at its top performance level for years to come.

SPECIFICATIONS

GENERAL

FREQUENCY RANGE: 2 to 12 MHz. Four bands; 2-3, 3-5, 5-8 and 8-12 MHz.
CHANNELS: Up to 8 single frequency simplex or 4 two frequency simplex. All crystal controlled.
OPERATING MODE: A3J emission. Upper or lower sideband standard. USB and LSB optional. CW option.
FREQUENCY TOLERANCE: +/-100 Hz. Internal adjustment to calibrate all channels.
TEMPERATURE RANGE: 0 to 40 degrees C, operating, -20 to 55 degrees storage.
TUNER CONTROL: Channel Selector control selectively connects one of eight pins to a common

pin to operate preset tuners or linear amplifiers.

BAND PROGRAMMING: Two shorting connectors can be field modified to change the channel/band plan.
POWER REQUIREMENTS: 12 to 14 V dc, 18 A maximum, negative ground. Built-in over-current circuit breaker.

CONSTRUCTION: Case and chassis all metal. Modular PC boards except power amplifier.

SIZE: HWD 5"x11-3/8"x12-1/8". (12.7x28.9x30.8 cm).
Bail not extended.

WEIGHT: 10 lbs. (4.5 kg).

RECEIVER

SENSITIVITY: 0.3 uV for 10 dB S+N/N, maximum.

SELECTIVITY: 2.4 kHz bandwidth @ 6 dB, 6.0 kHz @ 60 dB. Six pole filter at 12.7 MHz.

CLARIFIER: +/-100 Hz, typical, receive only.

DYNAMIC RANGE: 95 dB, typical.

I-F REJECTION: Greater than 60 dB.

SQUELCH THRESHOLD: Down to 1 uV input.

METER: Automatic switching. Reads "S" Units to 30 dB over S9. S9=50 uV.

AUDIO OUTPUT: 4 watts @ 8 ohms, 300-3000 Hz.

TRANSMITTER

MAXIMUM POWER INPUT: 200 watts.

POWER OUTPUT: 90-100 watts @ 13.5 V dc.

TUNE POWER: Approximately 25 watts of carrier generated when CARRIER push-button is depressed for antenna tuneup and frequency adjustments.

DUTY CYCLE: 100% SSB; 100% RTTY with external cooling fan directed at heatsink.

RF OUTPUT IMPEDANCE: 50 ohms, unbalanced.

SIDE BAND GENERATION: Balanced modulator through 6 pole filter.

SWITCHING MODE: Push-To-Talk (PTT) switch on microphone. VOX optional.

CARRIER SUPPRESSION: 50 dB minimum.

UNWANTED SIDE BAND: 40 dB, minimum @ 1 kHz.

SPURIOUS AND HARMONIC RESPONSES: Greater than 40 dB below full power rating.

AUTOMATIC LEVEL CONTROL: Internal threshold adjustment. LED indicator.

MODULATION: Speech compression circuits automatically maintain optimum modulation level. Internal presets for degree of compression and microphone sensitivity.

METER: Automatically switches when transmitting. Reads Standing Wave Ratio (SWR) calibrated to TUNE power reference.

VOX/CW OPTION: Three internal controls for level, delay and anti-vox. CW offset of 800 Hz.

MICROPHONE INPUT: Low impedance types with 5 mV level, minimum. Polarizing voltage for Model 700-C Electret Microphone (supplied) available at connector. Standard four terminal locking type connector.

FRONT PANEL CONTROLS AND CONNECTIONS

CHANNEL SELECTOR switch: **VOLUME control:** **POWER ON/OFF switch:** **SQUELCH/OFF control and pull switch:** **CLARIFIER control:** **USB/LSB switch:** **PTT/VOX-CW switch:** **NB (Noise Blanker) switch:** **MIC connector:** **PHONES jack.**

REAR PANEL CONNECTORS

POWER socket: CARRIER switch: PATCH-IN and OUT jacks: AUX 12 VDC jack: T/R control jack: CHANNEL SWITCH connector.

INDICATORS

Illuminated panel meter (signal strength and SWR): Modulation Light Emitting Diode (LED).

SECTION II INSTALLATION

NOTICE: Sections II and III (INSTALLATION and OPERATION) of this manual assume that all desired operating crystals and options are installed in the transceiver. If this is not the case, refer to Section IV, INSTALLING CRYSTALS AND OPTIONS, before proceeding with this section.

GENERAL

For fixed station installations, choose an operating location that is cool and dry. Allow adequate ventilation around the heat sinks on the

rear panels of both transceiver and power supply. For normal intermittent transmissions, natural convection cooling is all that is required. During mobile operation, free access to cool air should be provided. Do not direct the outlet vent of the automobile's heater directly at the transceiver.

To reduce the possibility of stray rf pickup on interconnecting cables, which may cause undesirable parasitic oscillations, and provide a measure of safety to the operator from possible shock in ac powered systems, all station equipment should be well grounded to earth. It is also important to strap the equipment chassis together with short heavy leads, preferably with braid. This procedure brings all metal components that are accessible to the touch to the same potential, removing the possibility of shock when touching more than one piece of equipment. Also, the extra strap between transceiver and power supply chassis serves to reduce voltage loss on the negative 13 volt supply lead caused by resistance in the cable and connector contacts. If a metal operating table is used, be sure to ground it also. In mobile installations, connect a ground strap between the rear panel GND post and the vehicle's chassis.

Earth ground leads should be of heavy wire or braid and be as short as possible. Attach securely to a ground rod driven into the earth near the operating position.

FIXED STATION INTERCONNECTIONS

A supply of 12 to 14 volts dc, capable of supplying 18 to 20 amperes, negative ground, is required. Voltage regulation of 5% or better between no load and full load is recommended for distortion-free transmissions, although unregulated supplies may be used without damage to the transceiver. Output power may fall below the specified value if the supply voltage drops below 13 volts. The transceiver may be operated directly from an automobile battery in fixed locations, provided that the voltage under full load does not fall below 11 volts. This requirement dictates that the battery be near full charge and that it be a relatively new battery. It is permissible to connect a slow charger across the battery to maintain the full charge condition.

For 115/230 volt ac operation, a well regulated supply is recommended. TEN-TEC Model 280 is fully regulated and has over-voltage and over-current protection circuits.

POWER CONNECTIONS

Power is supplied to the transceiver by means of the 4 pin AMP MATE-N-LOC type 1-480702-0 connector with type 350874-3 female terminals. The chassis connector is of the male type and mates directly with the cable connector supplied and attached to the Model 280 supply. It is only necessary to insert the cable connector into the chassis receptacle with the red wire in the cable going to the topmost pin marked (+) on the rear panel.

When using a dc source other than the Model 280 supply, it will be necessary to use the cable supplied with the transceiver. The cable is 5 feet (1.5 meters) long and of heavy gauge wire. Any excess length should be cut off to decrease the voltage drop in the cable to a minimum. The raised rib on the cable connector (see detailed drawing, Figure 2) is the negative black lead and mates with the bottom chassis terminal marked (-). The positive wire is white in the cable. The connectors are keyed so that they cannot be inserted incorrectly.

An extra power connector is supplied for construction of an additional cable, if needed. Wires should be at least 14 gauge with 12 gauge recommended for long runs. Pin connections are: Pin 1 = GND (negative) and Pin 4 = +DC. Pins 2 and 3 are not needed. Pin 1 has the raised rib on the cable connector. This connector is intended for high production automatic staking of the wires to the terminals. However, it can be assembled in the field without staking machinery by crimping and soldering the leads to the terminals, and inserting the terminals into the plastic shell. To do this, refer to Figure 2 and proceed as follows:

1. The terminals are supplied connected to a strip of flat metal. Break the individual connectors from the strip by bending back and forth at the point of narrow attachment, or by clipping them off with diagonals.
2. Wire sizes that can be accommodated range between 12 and 18 gauge. Strip insulation 1/4" back from end.
3. Insert stripped end into barrel far enough so that insulation just starts between large thin and small wide tabs.
4. With long nose pliers, roll over small tabs so that they hold bare wire.
5. Solder leads to rolled tabs by applying tip of iron to top of rolled tabs while feeding rosin core solder between wire and tabs. Do not allow solder to run into hollow tube.

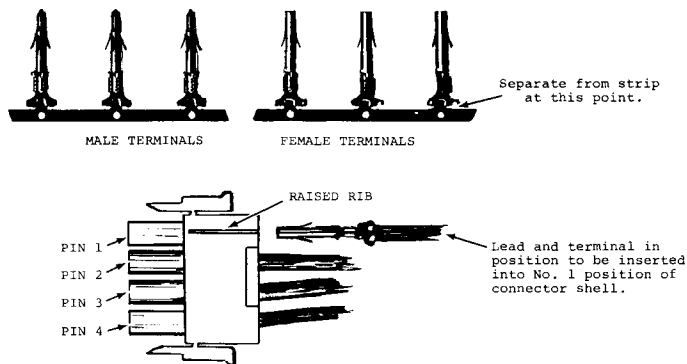

Figure 2 - AMP MATE-N-LOC Connector Detail

6. After terminals are well soldered, roll large thin tabs down over insulation and crimp with pliers.
7. Insert terminals into plastic shell from solid plastic end so that they finally locate in individual tubes. The terminals will automatically lock into place when inserted to the proper depth. **MAKE ABSOLUTELY CERTAIN THAT TERMINALS ARE INSERTED INTO CORRECT HOLES SINCE REMOVAL IS DIFFICULT.**

To remove terminals, an extractor is necessary to collapse the lanced holding tabs on the sides of each barrel. The extractor can be a metal tube, at least one inch (25 mm) long, with an outside diameter between 0.125" (3.2 mm) and 0.135" (3.4 mm) and an inside diameter of 0.100" (2.5 mm). Insert the extractor tube into the pin end of the shell over the terminal to be removed, to a depth of about 1/2" (13 mm). Pull on the wire and extract the terminal.

ANTENNA CONNECTION

Any matched antenna presenting 50 to 75 ohms impedance, one side grounded, will load satisfactorily. Random length wire antennas and open wire feed systems will require a matching network. Use coaxial RG-58 cable between the Model 150 and antenna or the transceiver side of the tuner. If a tuner is used, locate it as far as is practical from the immediate transceiver location. Do not place tuner on top of transceiver or close to the microphone or cables going to the power source. If different antennas are used for multiple channel operation, an antenna switch should be used to facilitate antenna changes. Remotely controlled antenna tuners and/or switches can be controlled by the transceiver CHANNEL SELECTOR switch by means of the CHANNEL SWITCH connector and suitable cable. (See CHANNEL SWITCH CONNECTIONS paragraph below).

The antenna must be matched to a 2 to 1 standing wave ratio or lower. To measure SWR depress the CARRIER switch on the rear panel and observe the SWR scale on the panel meter. A type PL-259 coaxial connector is required to connect the antenna lead to the transceiver.

For base installations, we recommend the use of one of our folded dipole broadband antennas (Model FD-2 or FD-3) which does NOT require any matching network or switching system. Model FD-2 covers the entire 2 through 12 MHz range of the transceiver and Model FD-3, which is one half the length of

the FD-2, covers frequencies above 3.5 MHz. Both have standing wave ratios below 2 to 1 across their operating bands.

CHANNEL SWITCH CONNECTIONS

If a remotely controlled antenna switch, tuner or linear amplifier band switch is to be activated by the transceiver's front panel CHANNEL SELECTOR switch, control lines are available at the CHANNEL SWITCH connector on the rear panel. This connector mates with a MOLEX type 03-06-2092 nine pin cable connector with male terminals (one supplied with each transceiver). These are similar to those used in the power cable but accept wire sizes between 24 and 30 AWG. Refer to the POWER CONNECTIONS paragraph above for construction details.

Terminal numbers, which are molded into the cable connector shell, are the same as the channel switch positions for Pins 1 through 8. Pin 9 connects to the movable contact on the selector switch. Therefore Pin 9 shorts to the pin that has the same number as the CHANNEL SELECTOR knob position. All terminals are insulated from the chassis and (+) supply line.

MICROPHONE CONNECTIONS

The microphone input circuit will accept any low impedance dynamic or electret type microphone, providing it produces at least 5 millivolts of signal. It should incorporate a normally open Push To Talk (PTT) switch which shorts to the chassis GND when in the transmit mode. The TEN-TEC Model 700-C Electret Microphone which is supplied with the transceiver is especially well suited to and compatible with the transceiver circuits.

The microphone connector is a standard 4 pin female microphone plug with a threaded locking ring. The pin numbers, which are molded into the plastic portion of the connector are: Pin 1= microphone signal; Pin 2= GND; Pin 3= PTT line; Pin 4= polarizing voltage for Model 700-C microphone. If you use a microphone other than an electret type, Pin 4 does not require a connection.

LINEAR AMPLIFIER CONNECTIONS

To facilitate switching a high power linear amplifier 'on' in the transmit mode, Model 150 incorporates a T/R relay that is energized whenever the PTT switch is closed or when the VOX option is triggered to the transmit mode. The contacts for this relay are brought out to the jack on the rear panel marked T/R. The center pin contact shorts to chassis GND during transmit. If the relay in the linear that controls this function is a 115/230 volt ac type, do NOT use the T/R line directly to activate it since it will connect the transceiver chassis to one side of the ac line - a dangerous situation. Rather use an intermediate 12 volt dc relay. The +12 volts for this relay may be drawn from the AUX 12 VDC jack on the rear panel. To reduce the possibility of rf pickup on interconnecting cables, use coaxial cable from the T/R jack, either RG-174 miniature cable or RG-58/59.

If the linear amplifier band changing is to be remotely switched by means of the transceiver CHANNEL SELECTOR switch, refer to the CHANNEL SWITCH CONNECTIONS paragraph above for cable information.

TELEPHONE INTERFACE

Two jacks are provided on the rear panel to gain

access to the transceiver's speaker and microphone lines. The PATCH IN jack connects directly across the speaker, thus providing an audio signal into the telephone coupler for transmission to the calling party. The voltage level on this line is approximately 1/2 volt under normal speaker volume and is controlled by the VOLUME control on the front panel. If the telephone coupler requires a lower voltage, a resistor attenuator should be inserted in the PATCH IN output line.

The PATCH OUT jack bridges the microphone input line so that the signal from the calling party out of the telephone coupler is applied to the transmitter section. Voltage level from the coupler should be approximately 10 millivolts to match that of the microphone. A separate level control in the coupler's output is recommended so that a balance between its signal and the microphone level can be attained.

Use shielded cables for both coupler connections, type RG-174 or RG-58/59.

MOBILE STATION INTERCONNECTIONS

POWER CONNECTIONS

Power requirements for mobile operation are the same as those outlined for base stations. When operating mobile, a power input cable of 12 gauge wire should be run directly from the battery terminals to the transceiver. Do not rely on the chassis to provide the negative connection, but run a wire directly from the negative battery terminal to the Model 150 power connector. Install Model 150 only in vehicles that have negative ground battery systems.

ANTENNA CONNECTIONS

Most mobile whip antennas will provide a near optimum match to the 50 ohm input but only over a very narrow frequency range without readjustment. In some cases additional matching components may be required to achieve an acceptable SWR below 2 to 1. Since whip antennas use the vehicle's chas-

sis as the ground plane, it is important that the shield of the coaxial cable at the base of the antenna be connected to a good chassis point. Trunk lids and some bumpers may require additional bonding to the main chassis with flexible straps or braid.

Resonating the whip antenna at the operating frequency is a relatively easy procedure since the SWR bridge is built into the transceiver. While depressing the CARRIER switch button on the rear panel, the resonant point can be determined by adjusting the whip length above the coil for minimum SWR. Make changes in 1/8" or 1/4" (3 to 6 mm) increments since the resonant dip is quite narrow, especially on the lower frequencies. If the SWR is above 2 to 1 at the resonant dip, a better match can usually be achieved by connecting a small capacitor across the base of the antenna to chassis. For single channel operation, the value can be determined and the capacitor permanently soldered in place. For multi-channel operation, a rotary switch in a small metal box can be located near the antenna base, in the trunk for instance, and the proper capacitor selected in this manner. Use mica capacitors with at least 500 volt ratings. Typical values for 4 MHz may be between 470 pF and 1000 pF with values decreasing as frequency is increased. Addition of the capacitor may require a slight touch-up in antenna length.

Although the noise blanker option is effective in reducing ignition noise, it is best that the installation be such that ignition noise is reduced as much as possible without the blanker. Use of resistor spark plugs and low noise ignition cables and noise suppressors in the distributor circuits are very effective in reducing interference. Also, strap the hood to a good chassis point with flexible metal or braid if it is not already well grounded. Locate the antenna as far as is practical from the engine - either on the rear trunk deck or bumper. And since the muffler and exhaust systems on most vehicles are supported and effectively insulated from the chassis with rubber shock mounts, they may carry ignition noise currents to the antenna location at the rear of the vehicle. Strapping the tail pipe or muffler to the chassis may substantially reduce ignition pickup.

SECTION III OPERATION

NOTICE: Sections II and III (INSTALLATION and OPERATION) of this manual assume that all desired operating crystals and options are installed in the transceiver. If this is not the case, refer to Section IV, INSTALLING CRYSTALS AND OPTIONS, before proceeding with this section.

GENERAL

Special care has been taken in the design of the Model 150 to insure stable frequency characteristics. As a consequence, no warm-up time is necessary when first turning the unit on or when changing channels. The unit is ready to transmit or receive the second it is switched on.

The front panel controls that affect both the transmitting and receiving functions are:

POWER ON/OFF - This control provides the dual functions of switching power to the transceiver and protecting the transceiver's components in the

event of certain malfunctions. It incorporates a fast acting circuit breaker that will trip to the 'off' position whenever a current drain of over 24 amperes is asked of the battery or power source. This situation may be caused by a shorted or improperly matched antenna, improper supply voltage or failure of the transmitter final amplifier. When the breaker trips, the meter lamp will extinguish. If this happens, check to see if the abnormal condition is a temporary one by throwing the switch to the OFF position and then again to ON. If the breaker trips immediately, without speaking into the microphone, it indicates trouble in the final amplifier. If it trips only when speaking into the microphone, it may be that the antenna system is defective or slightly out of tune, causing a SWR greater than 2 to 1.

CHANNEL SELECTOR - This control selects the operating frequencies as determined by the crystals specified for the various channels.

USB/LSB Switch - When the UL option is installed this switch selects either upper or lower sideband operation for both transmit and receive modes. Without the UL option, the mode of operation will be that of the installed filter (U or L) in both switch positions. A clear plastic locking switch plate may be installed in transceivers without the UL option, in the position correct for the filter that is installed.

RECEIVING

Controls that need adjustment when receiving are:

VOLUME - This control sets the level of audio from the speaker. It also sets the level from the PHONES jack on the front panel, as well as the level present at the PATCH IN jack on the rear panel.

SQUELCH/OFF - When turned fully counterclockwise signals over approximately one microvolt will open the audio channel. As the control is rotated in the clockwise direction, higher levels of incoming signals will be required to open the audio. In the full clockwise position, the channel will remain closed at all times.

Squelch is most used when monitoring a channel and the background noise is disturbing. With the VOLUME control set to its normal position, rotate the SQUELCH control clockwise until the background noise is turned off. Any signal coming in above the noise level will open the audio channel. In cases where atmospheric noise bursts are present, adjust the SQUELCH control just a bit past where normal background noise is eliminated to catch some of the lower noise bursts. Of course, if they are too severe, the channel will be opened momentarily. To fully disable the squelch function, pull the SQUELCH knob out.

CLARIFIER - This control may be used to adjust the tone of the voice being received to make it more intelligible. Unless the received signal is considerably off frequency, the control will normally be set to the center position, where a slight detent will be felt.

NB-OFF Switch - If the NB option is installed, this switch turns the noise blanker on and off. A clear plastic locking switch plate may be installed in transceivers without the NB option.

The noise blanker is designed to eliminate or reduce impulse type noise, such as from automotive ignitions, small dc motors and certain types of ac line noise. Certain continuous disturbances, such as background and atmospheric noises, are less discernable by the blanker and consequently are not eliminated or reduced to the same degree as impulse noise.

PHONES Jack - When headphones are plugged into this jack the speaker is automatically disconnected. An extension speaker may also be powered from this jack. Although the audio amplifier is designed for an 8 ohm load, external speakers between 4 and 16 ohms will work satisfactorily. If you desire to connect a remote speaker without disabling the internal speaker, use the PATCH IN jack on the rear panel.

Headphones of any impedance will also work directly from the PHONES jack. However, since the amount of power needed to drive headphones to a satisfactory level is much less than for a speaker, it is recommended that an attenuator be used between the PHONES jack and low impedance headphones. The attenuator will greatly reduce residual internal noise. A simple resistor network consisting of a

15 ohm resistor in series with the phones and a shunt resistor of 2.7 or 3.3 ohms across the phones should be satisfactory. The resistors, both 1/4 watt types, can be soldered to the phone plug terminals and concealed in the shell of the male plug. The attenuator is not necessary with high impedance headphones since the power to them is automatically reduced when connected to the low impedance source.

METER - When receiving, the panel meter indicates relative strength of the signal being received. It is calibrated for a 50 microvolt input signal reading of S9. Each 'S' unit is a ratio of approximately 6 dB or a two-to-one voltage change.

TRANSMITTING

The front and rear transmitting controls are:

PTT-VOX/CW Switch - This switch selects either the Push-To-Talk or Voice Operated Transmit method of switching the transmitter on when the VOX option is installed. Without this option, only the PTT method is operable and a clear plastic locking switch plate may be installed over the switch actuator. When the microphone PTT lever is depressed the transceiver automatically transmits ssb. There is no transmit/receive switch to actuate. Hold the microphone closely to the mouth and speak clearly. The transceiver circuits automatically adjust the level of signal from the microphone so that maximum available power is transmitted. This is indicated by the periodic flashing of the Light Emitting Diode (LED) over the PTT switch. If the LED does not light on voice peaks, hold the microphone closer and talk louder.

When the VOX option is installed, either switching mode may be selected by the PTT/VOX switch. In the VOX position the PTT switch on the microphone must be continuously activated. For this reason VOX is most used at the base station where the microphone, such as the TEN-TEC Model 214, has a toggle rather than a spring return type of PTT switch. Handheld mobile types do not lend themselves well to VOX operation. With VOX, whenever sound over a certain level enters the microphone (internally adjusted), the transceiver automatically switches to the transmit mode. It reverts to the receive mode automatically after a pre-determined period of silence (also internally adjusted).

CW Operation - The VOX option also allows code transmissions. Insert the cw key or electronic keyer into the jack on the rear panel marked KEY. Whenever the key is depressed a continuous carrier is transmitted either 800 Hertz above or below the channel frequency, depending on whether the transmitter is set up for upper or lower sideband transmissions. This 800 Hz frequency offset eliminates detuning a similar receiver listening to the transmitted code that would otherwise be necessary to produce an audible beat note. When operating cw, both the transmitter and receiver should be operated on the same sideband and carrier frequency.

When the key is closed a tone emanates from the speaker to enable the operator to monitor his sending. The volume of this tone is preset internally and is not affected by the front panel VOLUME control setting.

CARRIER Switch - This push button switch, located on the rear panel, causes a continuous carrier to be transmitted at the carrier frequency whenever it is depressed. It is used whenever antenna SWR measurements are taken, when adjusting antenna or tuner or when calibrating the crystal oscillators. So as not to cause the magnetic circuit breaker to trip when adjusting antennas or tuners,

the power output is reduced to a safe level. A frequency counter can be connected to the COUNTER jack on the rear panel for oscillator adjustments.

METER - When transmitting, the panel meter indicates the reflected power. It is calibrated in SWR units based on the reduced power level present when the CARRIER switch is depressed. Therefore it will be an accurate indication of the degree of antenna match when this switch is actuated. Under normal ssb and cw operation the scale deflection will be amplified because of the higher power out.

With proper antenna match, the meter should NOT move appreciably from its resting position when talking into the microphone. If it does, check and adjust the antenna/tuner system by depressing the CARRIER button.

OPERATING HINTS

1. The movable bail is primarily intended to raise the front to a convenient slanting position. It may also be used as a carrying handle.
2. Due to the possibility of high voltage transients being generated in the rf amplifier during channel switching, change channels only in the receive mode.
3. When operating mobile, always turn transceiver off when starting or stopping the motor. High voltage transients from the generator may appear on the 12 volt line before the vehicle's regulator contacts close.
4. A lightning arrestor on all base station antenna lead is recommended.
5. During lightning and thunder storms, disconnect antenna from transceiver and close down operations. Ground all antennas if possible.

IF YOU HAVE TROUBLE

Below is a list of common faults that may cause the transceiver to malfunction. All are caused by faulty components external to the Model 150, or from an oversight on the operator's part. If trouble is suspected within the transceiver, refer to Section VI, MAINTENANCE, for detailed information.

SYMPTOM - Transceiver dead. No meter lamp illumination.

POSSIBLE CURES - Operate power switch to OFF position and then back to ON to reset tripped circuit breaker.

If using a TEN-TEC power supply make sure its switch is on.

Check power cable from supply or battery.

Check battery/supply for correct voltage.

Check 20 ampere fuse inside transceiver on back panel. (Remove top cover.)

SYMPTOM - 20 ampere fuse is blown.

POSSIBLE CURES - Check for reverse polarity on 12 volt line. Correct cable wires or connector termination.

SYMPTOM - Both receiver and transmitter dead. Meter lamp lights.

POSSIBLE CURE - Check position of CHANNEL SELECTOR switch for possible setting to a channel that does not have crystal installed.

SYMPTOM - Receiver dead. Transmitter OK.

POSSIBLE CURES - Check to see if headphones are plugged in, disabling speaker.

Make sure SQUELCH is not advanced too far clockwise. Pull SQUELCH knob out.

Check microphone cable/connector for continuous short between Pins 2 and 3.

If microphone has toggle type PTT switch, make sure it is not in 'transmit' mode.

SYMPTOM - Receiver OK. Does not switch to transmit mode when PTT switch on microphone is closed.

POSSIBLE CURES - Check microphone cable, connector and PTT switch.

If VOX option is installed make sure PTT-VOX/CW switch is in PTT position.

SYMPTOM - Receiver OK. Switches to transmit mode but LED does not flash on when speaking into the microphone.

POSSIBLE CURE - Check microphone, cable and connector.

SYMPTOM - Set seems alive but received signals are weak or non-existent. High SWR when transmitting.

POSSIBLE CURES - Check antenna system and cables. Check settings of tuner if used.

Try dummy load to determine if problem is in the antenna. (SWR should be near 1:1 with 50 ohm dummy load.)

SECTION IV

INSTALLING CRYSTALS AND OPTIONS

GENERAL

Model 150 may be shipped from the factory with or without channel crystals and/or options, depending on the purchaser's requirements. Crystals and certain options may be installed in the field after delivery. This section gives crystal specifications, crystal installation and calibrating procedures, instructions to alter the channel/band scheme in the Model 150-A units and instructions for installing the UL and NB options. The VDX/CW and TFS (Two Frequency Simplex) options cannot be added in the field since they require replacement of several printed circuit boards and rewiring of several cables.

Model 150-B single band transceivers cannot be modified to result in a Model 150-A four band unit nor is it possible to change a Model 150-B from one band to another.

PROGRAMING

The programming function serves to set up the Model 150-A four band transceiver so that the desired channel frequencies correlate with the positions of the CHANNEL SELECTOR switch. Any frequency between 2 and 12 MHz can be assigned to any of the 8 switch positions. This information is programmed into the switching circuits by means of a small cable with two removable connectors. To change the program it is only necessary to rearrange the wires in this cable. **NOTICE:** If the Model 150-A is shipped from the factory without any crystals installed, the cable is NOT fabricated - only the two unconnected connectors are inserted into their mating PC board connectors. The transceiver will be inoperative, even with crystals installed. In Model 150-B transceivers no programming is necessary since all channels operate within the specified band.

To construct or change an existing programming cable, first draw up a table listing the desired operating frequency for each channel, and determine which band is required.

The bands are as follows:

- Band 1 - 2 to 3 MHz
- Band 2 - 3 to 5 MHz
- Band 3 - 5 to 8 MHz
- Band 4 - 8 to 12 MHz

A typical table might be as follows:

CHANNEL NUMBER	CHANNEL FREQUENCY	BAND
1	2.40 MHz	1
2	2.75 MHz	1
3	4.80 MHz	2
4	9.11 MHz	4
5	2.13 MHz	1

Constructing The Cable

Remove the bottom of the transceiver and locate the BAND SWITCH subassembly, Pt.No. 80994, located at the front left side. Figure 3 is a reproduction of the top printing on this PC board. The two connectors are numbered 54 and 55. Connector 54 is the 'band' connector and has four terminals. Connector 55 with eight terminals is the 'channel' connector. Figure 3 shows enlarged views of these with the terminal numbers called out.

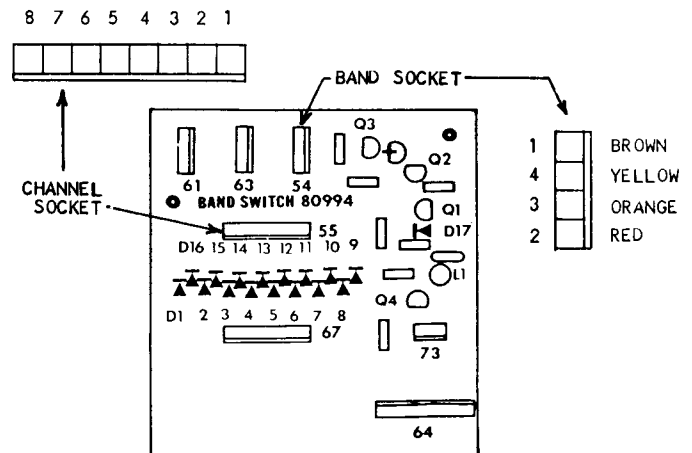

Figure 3 - BAND SWITCH Assembly Printing

The cable connectors are of the insulation-displacement type whereby wire connections using #24 AWG stranded wire are made by forcing the unstripped wire into the terminal. The sharp edges of the terminal cut into the plastic insulation on the wire and make a reliable connection without solder. However, a special insertion tool is required to make reliable connections in this manner. For field construction it is recommended that the wire be stripped back about 1/8" (3 mm) and after being forced into the terminal with a small blade screwdriver, soldered with a pencil iron and rosin core solder.

Construct the cable using the supplied brown, red, orange and yellow wires by first connecting a small length of brown wire to the #1 terminal of the 'band' connector and then over to all of the 'channel' terminals that require that band. Notice that the 'channel' connector allows the wire to pass through so that it can be routed to other 'channel' terminals as required. Proceed with the remaining bands.

In our example, the cable will be constructed as follows:

1. A brown wire will connect to 'band' terminal #1 and to 'channel' terminals #1, #2 and #5.
2. A red wire will go from 'band' terminal #2 to 'channel' terminal #3.
3. A yellow wire will go from 'band' terminal #4 to 'channel' terminal #4.

Notice that there will be no wire connected to 'band' terminal #3 since we do not require any 5 to 8 MHz operation. Also, the terminal sequence on the 'band' connector is not in numerical order but in the order 1,4,3,2 from top to bottom.

CRYSTAL SPECIFICATIONS

To meet published specifications it is imperative that crystals used in the Model 150 be of high quality and conform to the rigid specifications given here. They should be properly aged for maximum stability. The channel frequencies designated in these specifications are of the carrier and not the mid-channel frequency. In this way, the specified crystal frequency will be the same for either upper or lower sideband operation.

CASE: HC25/U (Plug in terminals)
 MODE: Fundamental
 RESONANCE: Parallel
 LOAD CAPACITY: 30 pF
 TEMPERATURE VARIATION: +/-50 Hz max. 0 to 40 degrees Celsius from the 25 degree value.
 FREQUENCY TOLERANCE: .002%
 EQUIVALENT RESISTANCE: 14-15 MHz = 22 ohms
 15-20 MHz = 20 ohms
 20-25 MHz = 18 ohms
 SHOCK: Maximum frequency change = .0005%
 Maximum resistance change = 10%
 VIBRATION: Maximum frequency change = .0005%
 Maximum resistance change = 10%
 AGING: Maximum frequency change = .0005%
 MARKING: Channel carrier frequency in MHz on top
 Crystal oscillating frequency on side
 FREQUENCY: 12.700000 + Channel Carrier Frequency
 in MHz

CRYSTAL INSTALLATION

Access to the crystals and calibrating components is by removal of the small cover plate on the bottom of the transceiver. The crystals are plugged into the multi-socket starting with Channel 1 closest to the front of the transceiver and proceeding toward the rear. Figure 4 is a reproduction of the printing on the top of the XTAL OSCILLATOR printed circuit assembly to which the crystal socket is attached. The crystal positions are clearly marked.

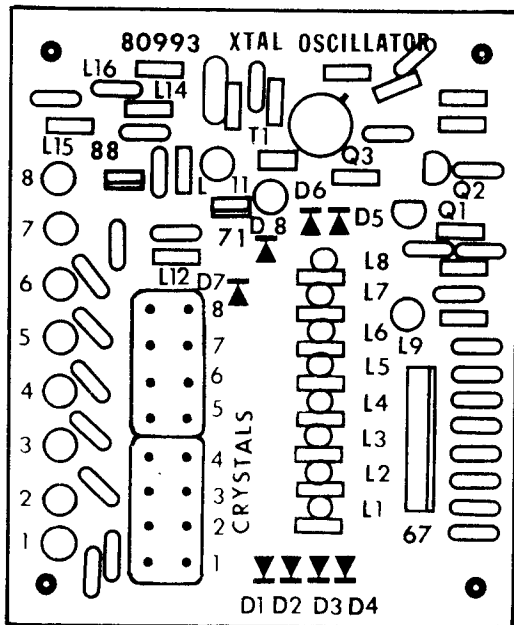

Figure 4 - XTAL OSCILLATOR Assembly Printing

Insert the appropriate crystals into their sockets, which are arranged in two groups of four. If the crystal cases do not have insulating plastic sleeves over them, place one of the small rubber bands supplied in the packing kit around each group of four or less crystals so that the cases touch one another. Intermittent contacts between cases will affect the oscillating frequency to a small degree if this is not done.

OSCILLATOR CALIBRATION

The small variable capacitors that calibrate each channel are also on the same printed circuit assembly and run along the left side of the board. The printed designations from 1 to 8 are plainly visible. To calibrate the oscillators proceed as follows:

1. Remove small cover plate from bottom of the transceiver. Do NOT remove bottom cover.
2. Connect output from the ANTENNA jack to a 50 ohm dummy load and power transceiver in the normal manner.
3. Connect an accurate frequency counter to the COUNTER jack on the rear panel. The counter should be capable of reading to 1 Hertz and be accurate to 5 Hz.
4. Rotate CHANNEL SELECTOR knob to channel that is to be calibrated.
5. Depress CARRIER pushbutton on rear panel and hold in while observing frequency counter. Using an insulated tuning wand, carefully adjust the corresponding capacitor so that counter reads the proper channel carrier frequency to within 5 Hz. The adjustment is very critical.

UPPER AND LOWER SIDEBAND FILTERS

The UL option provides both upper and lower sideband operation. If the transceiver does not presently have this option installed it will have either an upper or lower sideband filter, but not both. The filters are located on the SSB printed circuit assembly, No. 80988, accessed by removing the top of the transceiver. A reproduction of the printing on this board is given in Fig. 5. The filters are in rectangular metal cans, the USB filter located in the right center area and the LSB filter in the lower right. To install the missing filter proceed as follows:

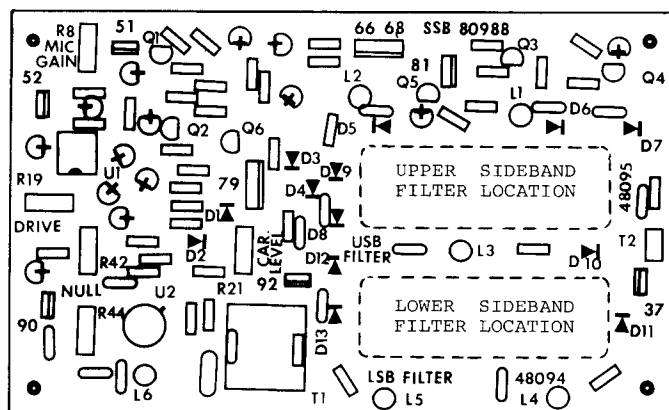

Figure 5 - SSB Assembly Printing

1. Remove top of transceiver by removing four side screws.
2. Unplug all cables going to this assembly. Notice that they are numbered both on the assembly and cable connectors. The two connectors in the upper left corner may or may not have cables connected, depending on

whether the VOX/CW option is installed or not. Also notice that there is a shorting plug in PC connector #81. Remove this connector also.

3. Remove the four screws at the corners of the assembly and lift assembly out.
4. Install the additional filter in the location provided and secure it with the 4-40 hex nuts and washers supplied.
5. With a small pencil soldering iron, solder the two remaining pins to the board, using rosin core solder.
6. Reinstall the assembly into the chassis. Make sure that the four tubular standoffs that space the board from the chassis have not fallen off of their retainers.
7. Reconnect all cables to their respective PC board connectors. Notice that when the connectors are correctly installed, the wires exit from the connector away from the raised locking tab on the PC board connectors. It is possible to incorrectly plug the cables into their sockets. (Observe other cables in transceiver for proper orientation.)
8. Plug the three wire cable supplied with the option into connector #81. Route this cable to the left side of the chassis and then forward to the toggle switch assembly on the front sub-panel.
9. Plug this end of the cable into the first three pins of the 9 pin connector on the toggle switch assembly that are nearest the left side of the transceiver. The wires coming from this connector should exit downward toward the chassis plate. FAILURE TO INSERT THE CONNECTOR CORRECTLY WILL RESULT IN IMPROPER TRANSMISSIONS.
10. Replace top cover.

Addition of the UL option does not require any alignment or circuit adjustments.

INSTALLING NOISE BLANKER

The NB option is easily added to the Model 150 as follows:

1. Remove top cover by removing four screws.
2. The blanker assembly will be located immediately behind the SSB assembly, in the upper left area. (See Figure 9, Inside Top View)
3. Insert the four retainers supplied with the blanker into the four mounting holes in the assembly from the top as shown in Fig. 6. Push four spacers over the retainers from the bottom. Insert four #4 sheet metal screws through the retainers from the top.
4. Carefully move any cables away from the area where the blanker will be mounted and position the board over the four small holes in

the chassis that match the screw locations. Orientation should be such that the printing on the PC assembly is upright and matches that of the other assemblies.

5. Remove the short two wire cable between connectors #37 on the SSB assembly, Pt. 80988, and #37 on the TX-RX MIXER assembly, No. 80989, to the right of it.
6. Install the longer shielded cable supplied with the blanker between connector #86 on the blanker assembly and connector #37 on the SSB assembly. (Refer to UL option information above for proper connector orientation.)
7. Connect the short shielded cable supplied between connector #85 on the blanker and #37 on the TX-RX MIXER.
8. Plug the two terminal connector #59 of the two wire cable into the mating connector on the blanker and route the cable along the left side of the chassis to the toggle switch assembly on the front sub-panel.

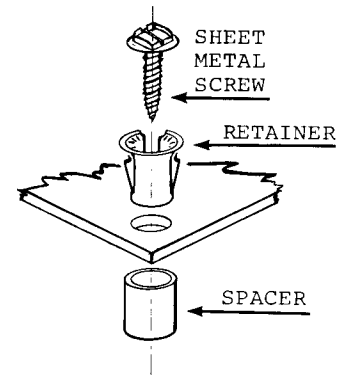

Figure 6 - PC Board Mounting

9. Plug the three terminal connector on this end of the cable into the three pins of the 9 pin connector on the toggle switch assembly that are farthest to the right. The wires should exit from this connector pointing toward the chassis plate and not toward the top of the transceiver.
10. Locate the two wire cable with connector #83 that is installed in the Model 150 but not connected to any assembly. Insert it into connector #83 on the blanker.
11. Secure the cables with the plastic cable ties supplied with the option.
12. Replace top cover.

Addition of the NB option does not require any alignment or circuit adjustments. The assembly has been pre-tuned at the factory.

11-150 1285

SECTION V CIRCUIT DESCRIPTION

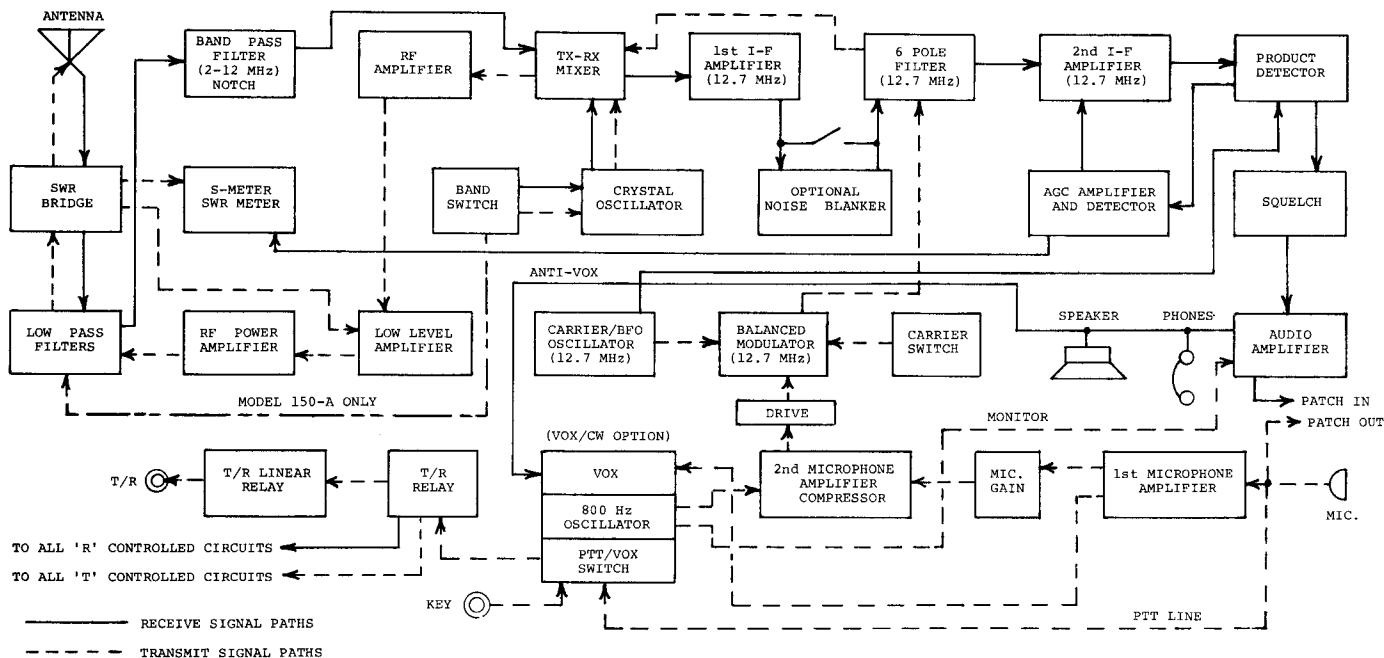

Figure 7 - Block Diagram

GENERAL

This section analyses the circuit design of the Model 150 in a general way. Both received and transmitted signals are traced through the various stages of the transceiver with the aid of the Block Diagram, Figure 7. Detailed information on the locations of the components used in the various sections is given in the alignment and servicing sections that follow.

The circuit approach used in the Model 150 represents the latest techniques developed for transistorized hf equipment. Both transmitter and receiver are wideband so that the operator is not required to adjust any tuned circuits in the use of the transceiver. The receiver front end is designed without an rf amplifier to achieve superior overload characteristics in cases where strong interfering signals are present. This is accomplished by feeding the antenna signal through a series of band pass and low pass filters and then directly to a high level diode ring mixer. The all solid state design results in prolonged component life due to lower operating temperatures within the unit and also simplifies battery, mobile and portable operation.

RECEIVER CIRCUITS

Referring to Figure 7, notice that all paths for the received signal are represented by solid lines connecting the various stages. The transmitted paths are dotted.

Starting at the antenna, the signal first travels unchanged through the SWR BRIDGE, which is a transmitting function. From there it passes through a 7 pole LOW PASS FILTER whose cut-off frequency is slightly higher than the high end

frequency of the band in use. In the Model 150-A, this filter is selected by the position of the CHANNEL SELECTOR switch on the front panel. In Model 150-B, the filter is permanently installed for the particular band designated in the specifications. The filter eliminates all signals higher in frequency than the operating range, that may interfere with the desired signal, especially when the undesired signal level is high.

The output from this filter is passed through a 14 pole BAND PASS FILTER whose range is 2 to 12 MHz. This further attenuates signals above the transceiver's range and also eliminates those below 2 MHz that may interfere. Within this filter are two trap filters tuned to 12.7 MHz, the intermediate frequency of the transceiver, effecting a very deep notch at this frequency. This eliminates any signal coming into the antenna circuit at 12.7 MHz from passing directly through the i-f amplifier.

From the filters the signal is applied to the TX-RX MIXER stage. This mixer is made up of 8 diodes in a ring configuration fed by two trifilar transformers. The local oscillator signal comes from the CRYSTAL OSCILLATOR whose frequency is selected by the BAND SWITCH.

From the mixer, the 12.7 MHz converted signal, which may contain either upper or lower sidebands, passes through the 1st I-F AMPLIFIER, which is broadly tuned. If the optional noise blanker is installed, the signal then is sent through a gated amplifier in the option, which turns the amplifier off during noise pulses. The output from the blanker, if installed, or the 1st I-F AMPLIFIER is then passed through the 6 POLE FILTER, a crystal filter with a 2.4 kHz bandwidth and very steep skirt attenuation. Depending on whether an upper or lower sideband filter is in the circuit, the

output from this sharp filter will contain either the upper or lower sideband frequencies, but not both.

From there the signal is amplified further in the 2nd I-F AMPLIFIER. The gain of this stage is controlled by the AGC voltage fed to it from the AGC AMPLIFIER AND DETECTOR. The PRODUCT DETECTOR converts the i-f signal to audio and amplifies it in a single integrated circuit stage. Carrier injection of 12.7 MHz to the PRODUCT DETECTOR comes from the CARRIER/BFO OSCILLATOR stage which contains a crystal controlled 12.7 MHz oscillator. The CLARIFIER frequency shift is generated in this oscillator with a varicap diode in the crystal circuit.

Output from the PRODUCT DETECTOR is routed to the AGC AMPLIFIER AND DETECTOR where it is further amplified and changed into a corresponding dc control voltage. This voltage drives the S METER and sets the i-f gain. Audio from the detector is also applied to the AUDIO AMPLIFIER through the SQUELCH gate. The squelch operates from a portion of the dc AGC voltage whose level is determined by the setting of the SQUELCH control.

Output from the AUDIO AMPLIFIER is transformer coupled to the speaker and/or headphone jack. If the VOX option is installed, it is also applied to the anti-vox portion of this option to prevent the sound of the incoming signal from turning the transmitter on. Audio from the primary side of the output transformer is applied to the PATCH IN jack on the rear panel for transmission into the telephone coupler.

TRANSMITTER CIRCUITS

The dotted paths in Figure 7 denote transmitted signal flow. Two signals, one an audio frequency voltage originating at the microphone, and the second a 12.7 MHz rf voltage from the CARRIER/BFO OSCILLATOR combine in the BALANCED MODULATOR to generate the basic sideband signal. Audio from either the microphone or the PATCH OUT jack is applied to the 1st MICROPHONE AMPLIFIER, through the MIC GAIN control and into the 2nd MICROPHONE AMPLIFIER/COMPRESSOR. The second amplifier also has circuits to automatically adjust the overall output level to a preset average value. Therefore if the operator speaks in a loud or soft voice, or moves the microphone closer to or farther from his lips, the automatic feature acts to offset these differences so that the transmitted signal is more closely held to 100% modulation.

Output from these stages is set with the DRIVE control, to the level required by the BALANCED MODULATOR. Both the DRIVE and MIC GAIN controls are internal adjustments.

This audio, in combination with the rf from the CARRIER/BFO OSCILLATOR, generates a 12.7 MHz double sideband, suppressed carrier signal that is applied to the 6 POLE FILTER, the same one that is used in the receiver. The filter passes only the desired sideband to the TX-RX MIXER stage. Again the proper local oscillator is applied to the transmit mixer from the CRYSTAL OSCILLATOR section. Output from the mixer, which is now converted to the channel frequency, is amplified in the LOW LEVEL AMPLIFIER and then to the 100 watt level in the RF POWER AMPLIFIER. The LOW LEVEL AMPLIFIER gain is adjusted automatically to the proper level by means of a dc control voltage derived in the SWR BRIDGE circuit. This automatic power leveling circuit prevents overmodulation in the event that too high a signal is developed in the previous stages. Signal splatter and spurious emissions are prevented in this manner.

Since the output from the RF POWER AMPLIFIER contains many harmonics of the channel frequency, they must be removed before being transmitted. The LOW PASS FILTER accomplishes this very effectively. This filter is the same as that used in the receiver section and is selected for high end cut-off by the CHANNEL SELECTOR setting through the BAND SWITCH programming. From the filter the signal passes through the SWR BRIDGE where the reflected power is sensed and indicated on the SWR METER. The forward power is sensed and applied as a dc control voltage to the LOW LEVEL AMPLIFIER.

If the VOX/CW option is installed, several additional functions operate in the transmit mode. First, an audio signal from the output of the 1st MICROPHONE AMPLIFIER is applied to the VOX circuit where it is amplified and converted into a dc control voltage that switches the T/R RELAY to transmit whenever the level is above a preset value. In addition, the PTT line from the microphone switch is applied to the PTT/VOX SWITCH portion of the option instead of directly to the T/R RELAY. The position of the PTT/VOX switch on the front panel determines which mode is operative.

When code is transmitted the KEY closure switches the transceiver into the transmit mode and turns on the 800 Hertz oscillator. Output from this oscillator is injected into the 2nd MICROPHONE AMPLIFIER and on to the BALANCED MODULATOR where it is converted into sidebands of the carrier frequency. The transmitted frequency, therefore, is either 800 Hertz above or below the carrier depending on what filter is in the circuit. A portion of the 800 Hertz signal is also applied to the AUDIO AMPLIFIER to serve as a monitor tone for the operator.

CONTROL CIRCUITS

The various circuits are powered by means of four basic voltages, two of which are controlled. Common circuits to the transmitter and receiver sections are fed from either the constant 13.5 volts or from a well regulated 8 volts. Also, since currents are high in the final RF POWER AMPLIFIER, the 13.5 volts to the final transistors' collectors are applied at all times except when the unit is turned off. There are two controlled voltages designated the 'R' voltage that is present whenever the receiver is operative, and the 'T' voltage when transmitting. Both of these are 13.5 volt sources and are switched on and off by the T/R RELAY which, in turn, is controlled by a transistor switch activated either by the PTT switch in the microphone or the output from the VOX control circuits. The final rf amplifier is turned on by application of the proper bias provided by the 'T' voltage.

Other control circuits include two transistor switches that insert either the upper or lower sideband filter when the UL option is installed. The transistors control switching diodes in the filter's input and output circuits. The NB option is turned on with the front panel switch that applies +13.5 volts to the noise blanker gating amplifier. The other NB circuits are powered in the receive mode from the constant 13.5 volts and are by-passed in the transmit mode through diodes that are switched on by the 'T' voltage. Finally, the low power TUNE circuits are activated with the CARRIER pushbutton switch on the rear panel. Depressing this switch first turns on the transmitter through the T/R RELAY and also unbalances the BALANCED MODULATOR to a small degree so that the correct amount of carrier frequency is applied to the 6 POLE FILTER.

SECTION VI MAINTENANCE

GENERAL

This section gives detailed alignment and service information to keep the Model 150 operating at peak performance levels. Six major areas are covered as follows:

1. List of necessary test equipment.
2. Chassis wiring information.
3. Internal adjustments.
4. Signal tracing and locating faulty circuits.
5. PC board replacement.
6. PC board repair.

TEST EQUIPMENT

Equipment required to service Model 150 includes:

1. Power Supply. 13.5 V dc @ 20 A, regulated.
2. Dummy Load. 50 ohm, 100 watt resistor.
3. Rf Wattmeter. 200 watts range, 50 ohm line. Good to 25 MHz, minimum.
4. Signal Generator. 2 to 15 MHz. Attenuator to 1 microvolt output.
5. Oscilloscope. Frequency range to 15 MHz minimum. 10 millivolts to 100 volts rms input. 10 to 1 low capacitance probe.
6. Audio VTVM. 10 millivolts to 10 volts rms.
7. Frequency Counter. 25 millivolt input. 2 to 15 MHz range. 1 Hz resolution. 5 Hz accuracy. High impedance input or 10 to 1 probe.
8. Audio Oscillator. 300 Hz to 3 kHz. Attenuator to 1 millivolt output.
9. Small Tools. Tuning wands, screwdrivers, cable assortment, etc.
10. Volt-Ohm-Milliammeter. 0-20 VDC, 0-1 ADC

Additional equipment that is desirable but not essential includes:

1. Spectrum Analyzer. To 50 MHz, minimum. Calibrated scales and input attenuator.
2. Two Tone Oscillator. Typically 800 Hz and 1.4 kHz signals. Pure tones with adjustable levels. Attenuator to 1 mV output.

CHASSIS CABLING

Model 150 is constructed using removable printed circuit assemblies that are interconnected with plug-in cables. The assemblies are mounted to the chassis on both top and bottom surfaces using three or more stand-off spacers. Refer to Figure 6 for mounting details.

Cables connecting the assemblies are numbered on both ends as are the mating connectors on the PC assemblies. Figure 8, Cable Wiring Diagram, details all chassis connectors routed between the assemblies as well as cables going to controls, meter, switches and other chassis mounted components. The dotted cables are those used with the NB and VOX options. Placement of the connectors in Figure 8 with regard to the PC assembly outlines is essentially that of the actual connector locations on the PC boards. The locking tabs on the PC connectors are represented in the drawing as double lines. Wires from the cable connectors should exit away from the locking tabs when correctly plugged in. The LED cable is operable in only one orientation.

INTERNAL ADJUSTMENTS

In addition to the 8 channel frequency calibrations, there are 26 internal adjustments located

on the PC assemblies. Nine of these are set while in the receiving mode and 17 while transmitting. Figures 9 and 10 are inside views of the top and bottom of the main chassis and all components that require adjustments are shown clearly. They are also denoted in the printing on the tops of the assemblies.

Since some of the settings are affected by other adjustments, it is recommended that they be made in the order outlined below. The following procedures assume that the transceiver is in working order.

RECEIVER ADJUSTMENTS

CAUTION: When making most receiver adjustments, the signal generator is connected to the ANTENNA connector. DO NOT switch the unit into the transmit mode with the generator connected or it may be damaged. To prevent accidental transmissions, unplug cable 53 located on the LOW LEVEL AMP. assembly but make sure that it is reconnected after completing the receiver alignment.

12.7 MHZ I-F TRAPS

These two traps are located on the TX-RX MIXER assembly and are marked NULL. Set CHANNEL SELECTOR switch to the highest frequency channel, preferably one in the 8-12 MHz band. If Model is 150-B, select highest frequency channel in its band. Apply a signal of approximately 12.7 MHz to the ANTENNA connector from a signal generator and adjust its level so that an S Meter reading of S4 or S5 is obtained. Adjust generator frequency so that S Meter peaks. Actual frequency will depend on whether upper or lower sideband is being used. Adjust both NULL capacitors for minimum meter deflection, using an insulated tuning wand. Readjust generator output to keep reading below S5. Null is very sharp.

I-F AMPLIFIER

There are two tuned inductances designated L4 and L5 on the IF/AF assembly that require peaking. Apply a small amount of signal from the signal generator at any channel frequency to the ANTENNA connector. Rotate CHANNEL SELECTOR switch to the channel of the same frequency and set generator level for an S4 meter reading. Adjust L4 and L5 for maximum deflection, keeping input level below S4 or S5.

NOISE BLANKER

If the NB option is installed, also peak T1 transformer on this assembly for maximum meter deflection, keeping input level below S4 or S5. T1 is the larger metal can on the PC board. The smaller one is designated L6 and is a broadly tuned component that rarely needs adjustment. In the event that impulse noise is present when an antenna is connected to the transceiver, switch NB on and adjust L6 for minimum noise in the speaker. (It is recommended that the position of this coil core be noted before attempting any adjustment and that the number of turns and direction also be noted when changing the core. In the event that no improvement in noise blanking is evident, return the core to its original position. The type of noise present may not be of the type that is reduced by the blanker.)

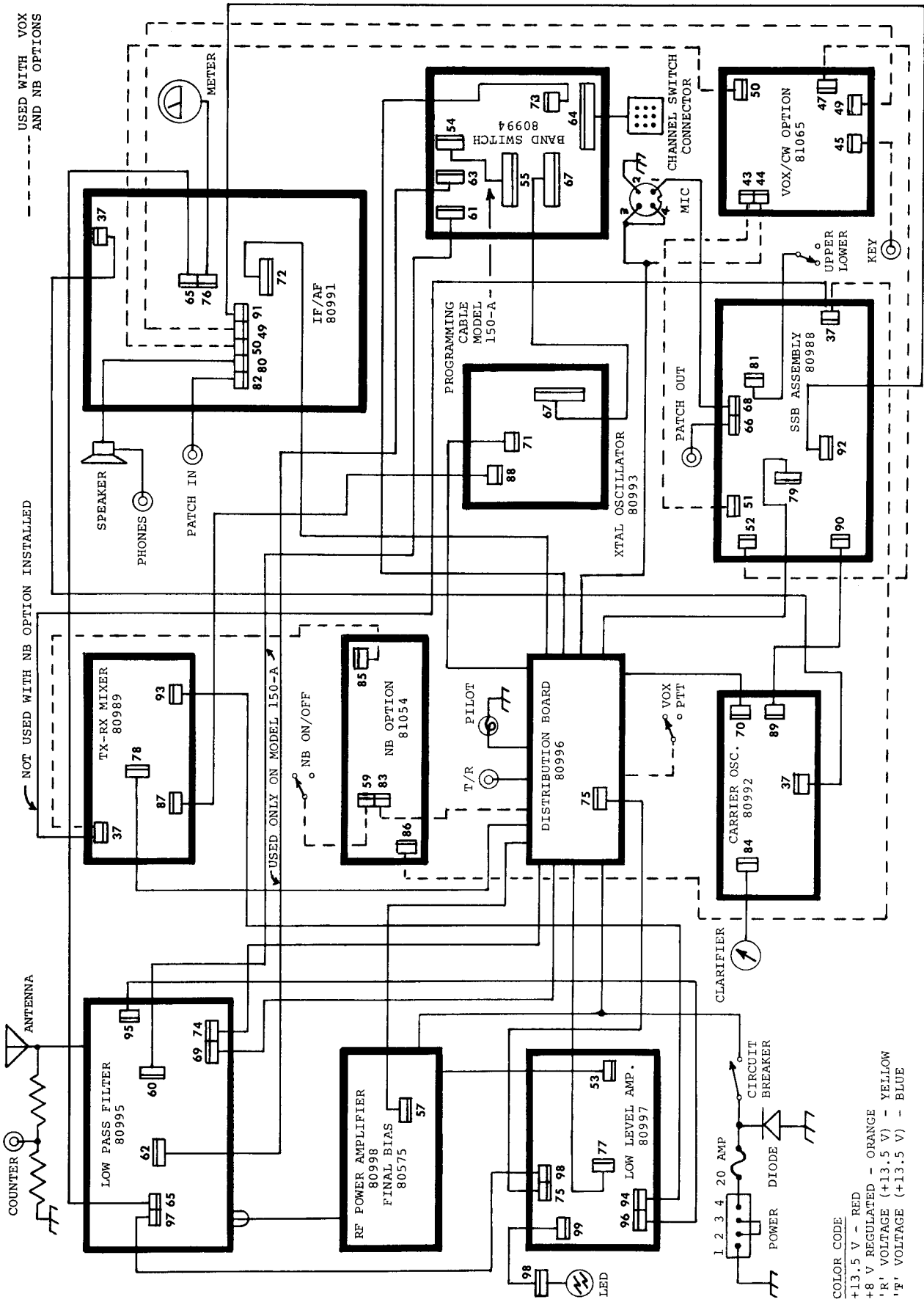

Figure 8 - Cable Wiring Diagram

15-150-1

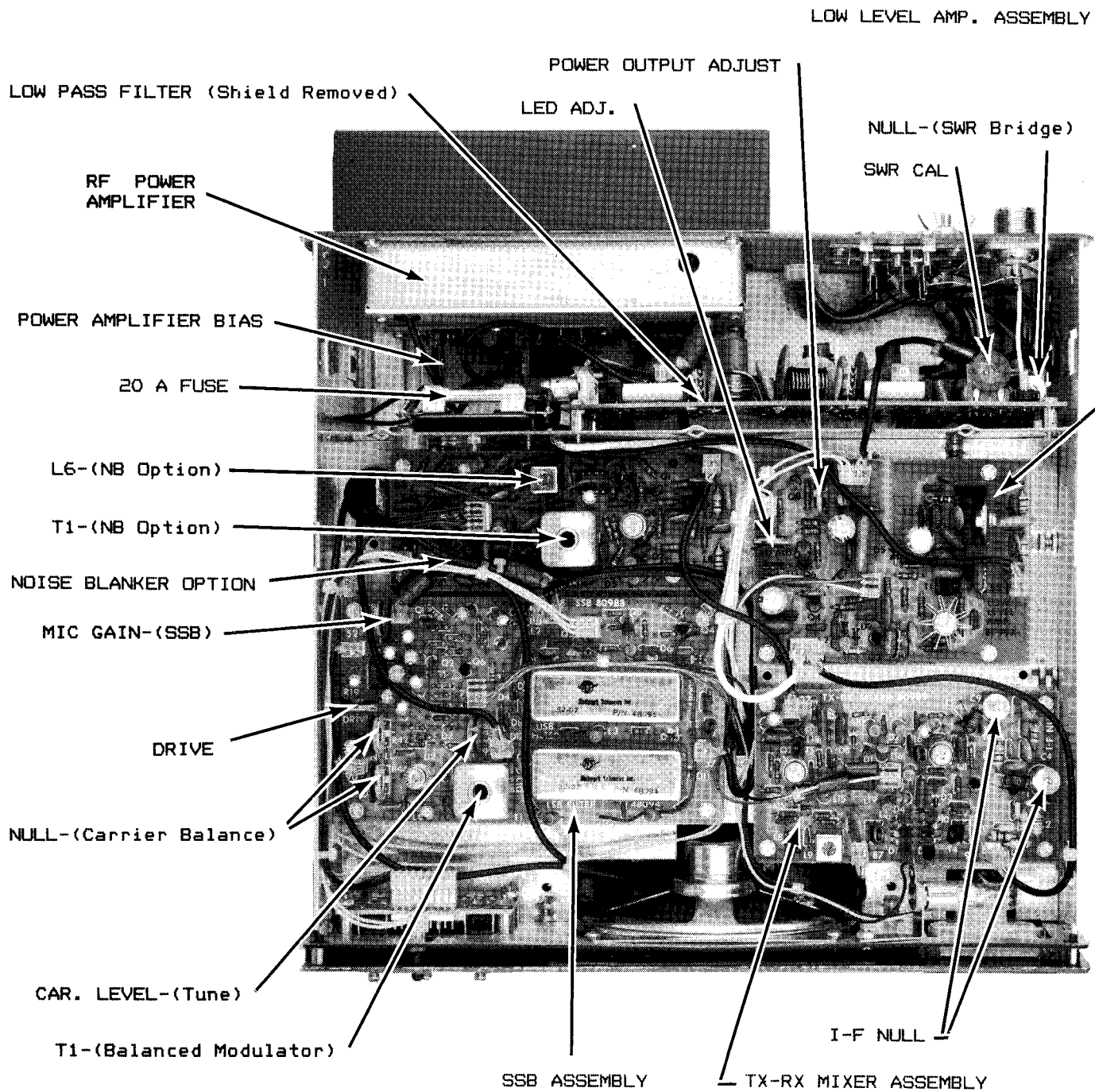

Figure 9 - Inside Top View

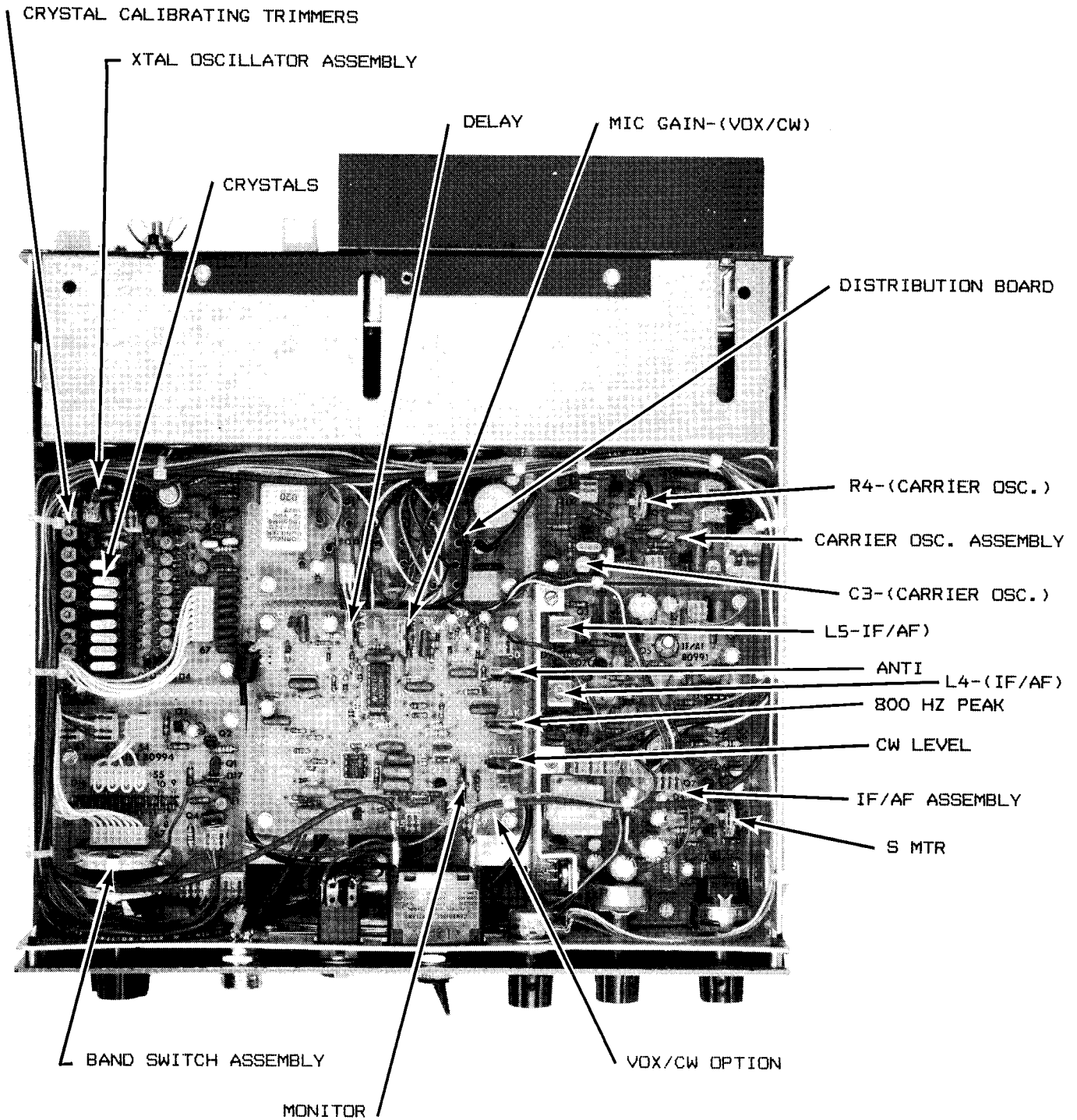

Figure 10 - Inside Bottom View

05121

S-METER CALIBRATION

Apply a 50 microvolt signal to the ANTENNA connector at a channel frequency between 3 and 7 MHz with Model 150-A units or midband with 150-Bs. Fine tune generator frequency for a maximum S-Meter deflection. Adjust trim potentiometer designated S MTR on the IF/AF assembly for a meter reading of S9.

CARRIER OSCILLATOR

There are two adjustments to the BFO oscillator on the CARRIER OSC. assembly. Trimmer capacitor C3 adjusts the frequency in the receive mode and trim potentiometer R4 sets it in the transmit mode. C3 must be adjusted before R4.

To set the frequency, first make sure that the CLARIFIER control is set to the center detent position. Connect the frequency counter to the #89 connector on the CARRIER OSC. assembly. Access to this point may be obtained by connecting the counter across the 680 ohm resistor located directly below the 89 on the board printing. The grounded end of the resistor is the lead farthest from the connector. To insure minimum loading of the oscillator circuit, connect the counter through a low capacitance 10 to 1 probe if available. Adjust C3 for a counter reading of 12.700000 MHz.

To adjust R4, leave the counter connected. Connect a 50 ohm dummy load to the ANTENNA connector and place the unit in the transmit mode by using the PTT switch on the microphone or by shorting Pin 3 of the MIC connector to chassis. Adjust R4 for the same 12.700000 MHz counter reading. The frequency should not change more than 5 Hz between the transmit and receive modes.

IMPORTANT NOTICE: Whenever the BFO frequency is changed, it results in a change in ALL channel operating frequencies. Therefore the individual channel oscillator crystals MUST be recalibrated whenever the BFO is readjusted. Crystal calibrating instructions are given below.

TRANSMITTING ADJUSTMENTS

POWER AMPLIFIER BIAS

This control is located on the small PC assembly 80575 that is attached to the outside cover of the RF POWER AMPLIFIER. To access this trim potentiometer, remove the top of the transceiver and the top shield covering the rear section of the unit. The control can be reached with the forefinger extended to it near the fuse. The potentiometer may also be accessed with a small insulated screwdriver inserted into the lower square cutout in the left side plate. This requires the removal of the bottom also.

To make the adjustment, locate the heavy red lead with the ferrite bead on it that goes between the left fuse terminal and the solder lug on the RF POWER AMPLIFIER assembly. Unsolder only this wire at the fuse terminal and connect a 0 to 1 ampere dc meter in series with this lead. With the dummy load connected to the ANTENNA connector, place the unit in transmit by shorting Pin 3 of the MIC connector to chassis. (Do not use the microphone PTT switch in this case since any room noise will modulate the transmitter and cause a false adjustment.) Adjust the bias potentiometer for a 500 milliamperere reading. After adjustment is made, resolder the red lead to the fuse terminal.

BALANCED MODULATOR

Rf transformer T1 on the SSB assembly is a broadly tuned circuit. To adjust, connect a dummy load through an rf wattmeter to the ANTENNA connector. Insert approximately 2 millivolts of a 1 kHz audio signal into Pin 1 of the MIC connector. Pin 2 is chassis ground. Make sure that level is low enough so that LED does NOT light when Pin 3 of the MIC connector is shorted to chassis. Adjust T1 for maximum power output as indicated on the wattmeter. (Keep output power below 50 watts during this procedure by adjusting audio input level.)

CARRIER BALANCE

Two potentiometers, both labeled NULL, are located on the SSB assembly. With a dummy load connected to the ANTENNA connector and the rf oscilloscope across the load, place the unit in transmit mode by shorting Pin 3 of the MIC connector to chassis. To reduce all possibility of hum modulating the transmitter from the open microphone line, short Pin 1 of the MIC connector to chassis also. Alternately adjust the two NULL controls for minimum scope deflection. It should be less than 700 millivolts peak to peak.

SWR BRIDGE NULL

There are two adjustments to the SWR bridge circuit, both located on the LOW PASS FILTER board. Access to these is direct if the top rear shield is removed, or through the openings in the shield marked NULL and SWR CAL. With a 50 ohm dummy load connected to the ANTENNA connector press the CARRIER pushbutton on the rear panel of the transceiver. The CHANNEL SELECTOR switch should be set to the highest frequency channel. Adjust the trimmer capacitor (NULL) with an insulated tuning tool for a minimum panel meter reading. The reading should go down to the '1' on the SWR scale if the load is a pure 50 ohm resistance. The SWR CAL. adjustment must be performed after certain other adjustments below.

LED ADJUSTMENT

The Light Emitting Diode modulation indicator requires a threshold adjustment. This potentiometer is labeled LED ADJ. and is located on the LOW LEVEL AMP. assembly. Put the unit into the transmit mode without modulation by shorting Pin 3 of the MIC connector to chassis. Adjust LED ADJ. control so that LED is definitely out but not too far past this setting. This is not a critical adjustment but if it is set too close to the turn-on point, it may stay on if the supply voltage to the transceiver rises above that used when making the adjustment.

POWER OUTPUT ADJUSTMENT

The maximum available rf output power from the transceiver is automatically kept to a preset level. The control that sets this level is located on the LOW LEVEL AMP. assembly. It is an unmarked potentiometer located just to the left of connector 75. Connect a wattmeter and dummy load to the ANTENNA connector and a 1 kHz audio signal of approximately 5 millivolts to Pin 1 of the MIC connector. Put unit in transmit mode by shorting Pin 3 of the MIC connector to chassis. Adjust the 1 kHz level until either the wattmeter reads 100 watts or until the LED comes on. 1.) If meter reads 100 watts without the LED coming on, turn trim potentiometer until output decreases to 90 watts at which point the LED should come on.

2.) If wattmeter reads below 90 watts when LED just comes on, increase 1 kHz signal slightly and readjust potentiometer so that output rises to 90 watts and LED comes on. 3.) If wattmeter reads approximately 90 watts at the point where LED just comes on, no adjustment is necessary.

CARRIER LEVEL IN TUNE MODE

When the CARRIER pushbutton on the rear panel is depressed, approximately 25 watts of carrier output power should be generated across the 50 ohm dummy load. This level is set with the CAR. LEVEL control located on the SSB assembly. With the rf wattmeter and dummy load connected, depress the CARRIER button and adjust CAR. LEVEL potentiometer for a wattmeter reading of 25 watts.

SWR CALIBRATION

To calibrate the SWR meter scale, either a 25 or 100 ohm, 100 watt non-inductive resistor is required. Two 50 ohm dummy loads connected in parallel will provide a 25 ohm load. While activating the CARRIER switch, adjust SWR CAL potentiometer on the LOW PASS FILTER assembly so that the panel meter reads '2' on the SWR scale, indicating a 2 to 1 ratio. If a 100 ohm load is used, the SWR is still 2 to 1.

MICROPHONE AMPLIFIER ADJUSTMENTS

There are two adjustments in the microphone audio stages. They are located on the SSB assembly and are marked MIC GAIN and DRIVE. They interact with each other and the final settings determine the degree of audio compression in the amplifier. The desired degree of compression is dependent on several factors. First, if various personnel are to use the equipment rather than only one operator, more compression is desirable to offset the variations in their voice characteristics and microphone placement. Second, if there is considerable room or background noise present, less compression is desirable so that these noises do not become a major modulating factor when not speaking into the microphone. Generally, it is more desirable to set up the system with less compression than would seem normal since the undesirable factors will not be as prominent and full modulation can still be attained by observing the LED indicator and adjusting your voice level and microphone placement. The set-up information given below is for an average set of conditions and is that used for factory adjustments.

1. Connect dummy load to ANTENNA connector and attach microphone that is to be used to MIC jack.
2. Initially set MIC GAIN control full on. To do this, turn the blue plastic rotor on the control fully counterclockwise when viewed facing the blue disk.
3. Press PTT switch on microphone and while speaking forcefully or whistling into the microphone adjust DRIVE control on SSB assembly to the point just past where the LED comes on.
4. Move microphone away from the lips to a distance judged to be the maximum that would normally be used when transmitting.
5. Again press PTT switch and talk in a normal voice. Readjust the MIC GAIN control downward to a point where the LED flashes only on voice peaks. Further movement of the microphone away from this point should cause the LED to remain unlit.

These are normal settings and both controls should be near their mid-rotation points. To decrease compression level, increase DRIVE setting slightly

(counterclockwise rotation) and make corresponding decrease in MIC GAIN setting (clockwise).

VOX/CW ADJUSTMENTS

If the VOX option is installed, there are six controls on this assembly that require adjustments.

1. MIC GAIN: Initially set the ANTI control fully off. This is done by turning the rotor fully clockwise when viewed head on. Connect a dummy load to the ANTENNA connector and the microphone to the MIC connector. Set the PTT-VOX/CW toggle switch to the VOX/CW position. If the microphone has a toggle PTT switch, set it to the normally transmit position. Without speaking into the microphone the transceiver should remain in the receive mode. While talking in a normal voice, adjust MIC GAIN control on the option assembly so that unit switches reliably into the transmit mode. If control is advanced too far, background room noise may put unit into transmit mode.
2. DELAY: While still operating as above, adjust control marked DELAY so that unit does not revert to the receive mode between words or sentences, but does after approximately one second of silence.
3. ANTI: This adjustment is made in the receive mode. Set up the transceiver as it would normally be placed on the table. Insert the microphone into its connector and place it where it normally would be when operating. Set PTT-VOX/CW toggle switch to VOX/CW and PTT switch on microphone to the transmit position. Connect an antenna to the unit and while receiving a station and not talking into the microphone, adjust ANTI control so that unit does not cycle into the transmit mode merely from the sound emanating from the speaker. Check to see that unit does switch to transmit when speaking into the microphone, since the ANTI adjustment has a slight effect on microphone gain. If needed, touch up MIC GAIN control.

There are three adjustments on the VOX/CW assembly that are used when sending code.

4. 800 HZ PEAK: Insert a key into the KEY jack on the rear panel. Set PTT-VOX/CW toggle switch to VOX/CW position. Connect an ac VTVM across connector 49 and rotate MONITOR control to mid position. While holding key down, adjust 800 HZ PEAK control for maximum VTVM reading.
5. MONITOR: With key still depressed, adjust MONITOR control so that level of tone coming from speaker is satisfactory.
6. CW LEVEL: This control should be set just past the point where the LED comes on when key is depressed. If the MIC GAIN and DRIVE controls on the SSB board are readjusted, the CW LEVEL should also be reset.

CHANNEL CRYSTAL CALIBRATION

Information to calibrate the individual channel crystals to their correct operating frequencies is given on Page 10 of this manual. If any adjustment is made to the carrier BFO oscillator, all crystal frequencies will have to be recalibrated accordingly.

It is important that the crystals be calibrated with the bottom cover in place, since there may be a slight frequency change due to the capacitive effects from the bottom.

LOCATING FAULTY CIRCUITS

To quickly locate the trouble area, make a close analysis of all symptoms of the malfunction. First determine if the problem is present in the receive mode, transmit mode or both. Also ascertain if it appears on one, several or all channels. This will narrow down the area as follows:

1. Fault Only In Receive Mode:
NB option if installed.
IF/AF assembly.
2. Fault Only In Transmit Mode:
LOW PASS FILTER assembly.
RF POWER AMPLIFIER assembly.
LOW LEVEL AMP. assembly.
3. Fault In Both Modes:
TX-RX MIXER assembly.
CARRIER OSC. assembly.
XTAL OSCILLATOR assembly.
SSB assembly.
BAND SWITCH assembly.
VOX option if installed.
4. Fault Only On One Or Several Channels:
LOW PASS FILTER and its relay circuit.
BAND SWITCH control and diode switching.
XTAL OSCILLATOR circuit and crystals.

Visual inspection of a suspected assembly may immediately uncover the trouble area. Look for browned resistors that indicate overheating, loose leads on components or a browned circuit path. Make sure that all cables are well seated in their sockets. Inspect connections on panel mounted components for cold solder joints.

If the visual inspection shows no signs of defective components, check the dc supply voltages to the suspected assemblies. The four voltage lines running throughout the transceiver have color coded wires in the cables, simplifying voltage checks. The constant 13.5 V line is RED, the constant regulated 8 V line is ORANGE, the 13.5 V transmit (T) line is BLUE and the 13.5 V receive (R) line is YELLOW. All cables originate at the DISTRIBUTION BOARD assembly. If voltage is present at this end of the cable but not at the assembly end, make sure that the cable is not faulty. The insulation displacement method of connection is very reliable but is not perfect. If a connection in the cable connector is suspected of being faulty, try applying a little pressure on the wire in the connector with a small bladed screwdriver while observing the voltmeter to see if the connection is intermittent.

If all cables check out satisfactorily, the fastest procedure to return the transceiver to operating condition is to start replacing the suspected PC assemblies. TEN-TEC spare parts kits BRF and RSK each have a set of replacement PC boards that

can be substituted one at a time. Repair of the faulty board is covered below.

REPLACING PC ASSEMBLIES

Replacement of assemblies is a simple task. All PC boards except the RF POWER AMPLIFIER/BIAS assembly are secured to the chassis with three or more screws and stand-off spacers. The RF POWER AMPLIFIER is attached to the rear panel with four machine screws.

To access the LOW PASS FILTER assembly, it is necessary to first remove the rear panel. The white wire going from the ANTENNA connector to the assembly will have to be unsoldered at the connector terminal. Several cables going to the RF POWER AMPLIFIER and the heavy red lead from the fuse post will have to be disconnected before the rear panel can be swung out of the way.

To remove either the BAND SWITCH or the IF/AF assembly, the front panel knob/s attached to the controls that are mounted on the assemblies must first be removed. Then with a flat 1/2" (13 mm) wrench, loosen the shaft nut/s located between the front panel and the sub-panel. There is one on the BAND SWITCH assembly and two on the IF/AF board. As the assembly is removed, loosen the nut/s until they are completely free of the threaded shaft. Also, it may be easier to remove the IF/AF assembly if the CARRIER OSC. board is first removed.

Unplug all cables going to the assembly to be removed and move them out of the way as needed. In some instances, this can be more easily accomplished if some of the plastic cable ties are removed with a diagonal cutter. A supply of extra ties is included with the spare parts kits.

When installing an assembly, make certain that the spacers are held to the PC boards with their retainers as shown in Figure 6. Tighten all mounting screws firmly since grounding between the circuit patterns and chassis is accomplished through the stand-offs.

PC ASSEMBLY REPAIR

GENERAL

Four servicing aids are given below to assist in the repair of defective assemblies. They are:
1.) A table listing the various circuit functions, the assembly on which they are located and the principal semiconductors and components that relate to their operation;
2.) A complete set of schematic drawings for all PC assemblies;
3.) Semiconductor termination drawings;
4.) A list of unique parts used on the assemblies and main chassis with schematic symbols and TEN-TEC part numbers.

FUNCTION TABLE

The listing below is separated into three areas; functions that relate only to the receive mode, those only to the transmit mode and those to both modes. The name of the PC assembly that contains the relevant circuits and the principal components involved are listed so that circuits may be traced using the schematic diagrams provided.

RECEIVE FUNCTIONS

FUNCTION	ASSEMBLY/SCHEMATIC	COMPONENTS
Band Pass Filter	TX-RX MIXER	All Capacitors/Inductances.
Receiver Mixer	TX-RX MIXER	Q2, D1, D4, D6, D7
1st I-F Amplifier	IF/AF	Q1
2nd I-F Amplifier	IF/AF	Q2, Q3, Q4
Product Detector	IF/AF	Q5
Squelch	IF/AF	Q9, Q10
Audio Preamplifier	IF/AF	U1A, U2
AGC Amplifier	IF/AF	U1B
AGC Detector	IF/AF	D5, D6, Q7, Q8
Anti-Vox	VOX Option	U1D, Q2, Q3
Noise Blanker I-F Amp.	NB Option	Q6
NB Gate Amplifier	NB Option	Q1, Q3, Q4, U1
NB T/R Switch	NB Option	Q2, D5 thru D10
NB Gate AGC	NB Option	Q5, Q7
NB Gate	NB Option	D1 thru D4

TRANSMIT FUNCTIONS

FUNCTION	ASSEMBLY/SCHEMATIC	COMPONENTS
1st Microphone Amplifier	SSB	Q1
2nd Microphone Amplifier	SSB	U1
Microphone Compressor	SSB	Q2, Q6
Balanced Modulator	SSB	U2
TX Mixer	TX-RX MIXER	Q1, D2, D3, D5, D8
RF Preamplifier	LOW LEVEL AMP.	Q1, Q2
RF Power Amplifier	RF POWER AMPLIFIER	Q1 thru Q4
Power Amplifier Bias	RF POWER AMPLIFIER	Q5, U1
SWR Bridge	LOW PASS FILTERS	D1, D2
Output Power Adjust	LOW LEVEL AMP.	Q4 thru Q7, Q9
LED Driver	LOW LEVEL AMP.	Q8
Audio Mute	IF/AF	Q6
TUNE Carrier	DISTRIBUTION BOARD	Q1
T/R Relay	LOW PASS FILTERS	Q1, RLY1
T/R Linear Relay	DISTRIBUTION BOARD	RLY1
800 Hz CW Oscillator	VOX Option	U2A, U2B
CW Key	VOX Option	Q1

TRANSMIT AND RECEIVE FUNCTIONS

FUNCTION	ASSEMBLY/SCHEMATIC	COMPONENTS
Carrier/BFO Oscillator	CARRIER OSC.	Q3, Q4, Q5
CLARIFIER Switching	CARRIER OSC.	Q1, Q2, D1, D2, D3
6 Pole Filter	SSB	USB, LSB Filters
6 Pole Filter Switching	SSB	D4 thru D13, Q4, Q5
TX/RX Mixer	TX-RX MIXER	D9
Channel Oscillator	XTAL OSCILLATOR	Q1, Q2, Q3
Channel Switching	BAND SWITCH	All components.
TX-RX MIXER Switching	TX-RX MIXER	D1 thru D8
Low Pass Filters	LOW PASS FILTERS	All Filter Components and Relays.
VOX T/R Switching	VOX Option	U1A, U1B, U1C, Q4
8 Volt Regulator	IF/AF	U3

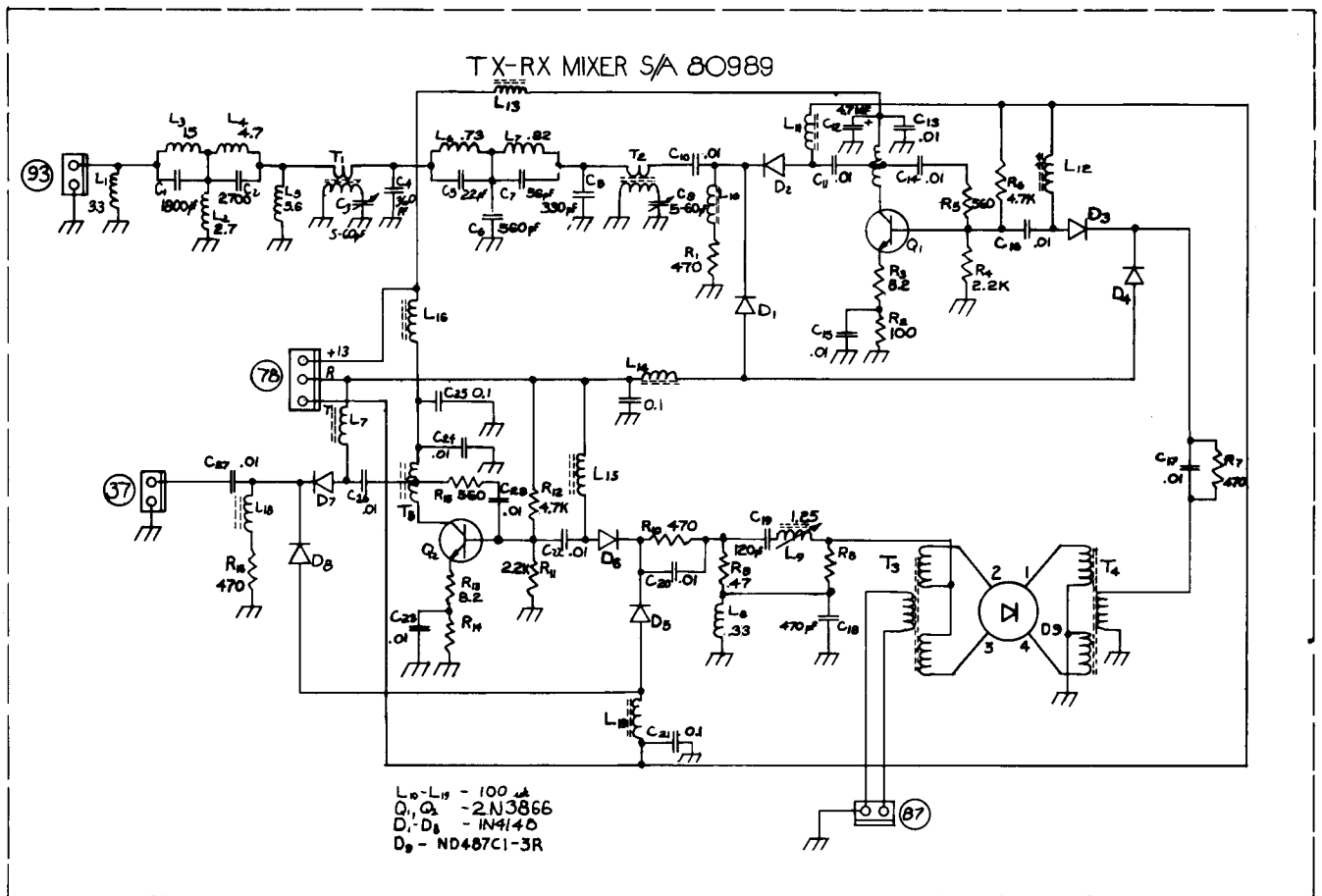

TX-RX MIXER Schematic

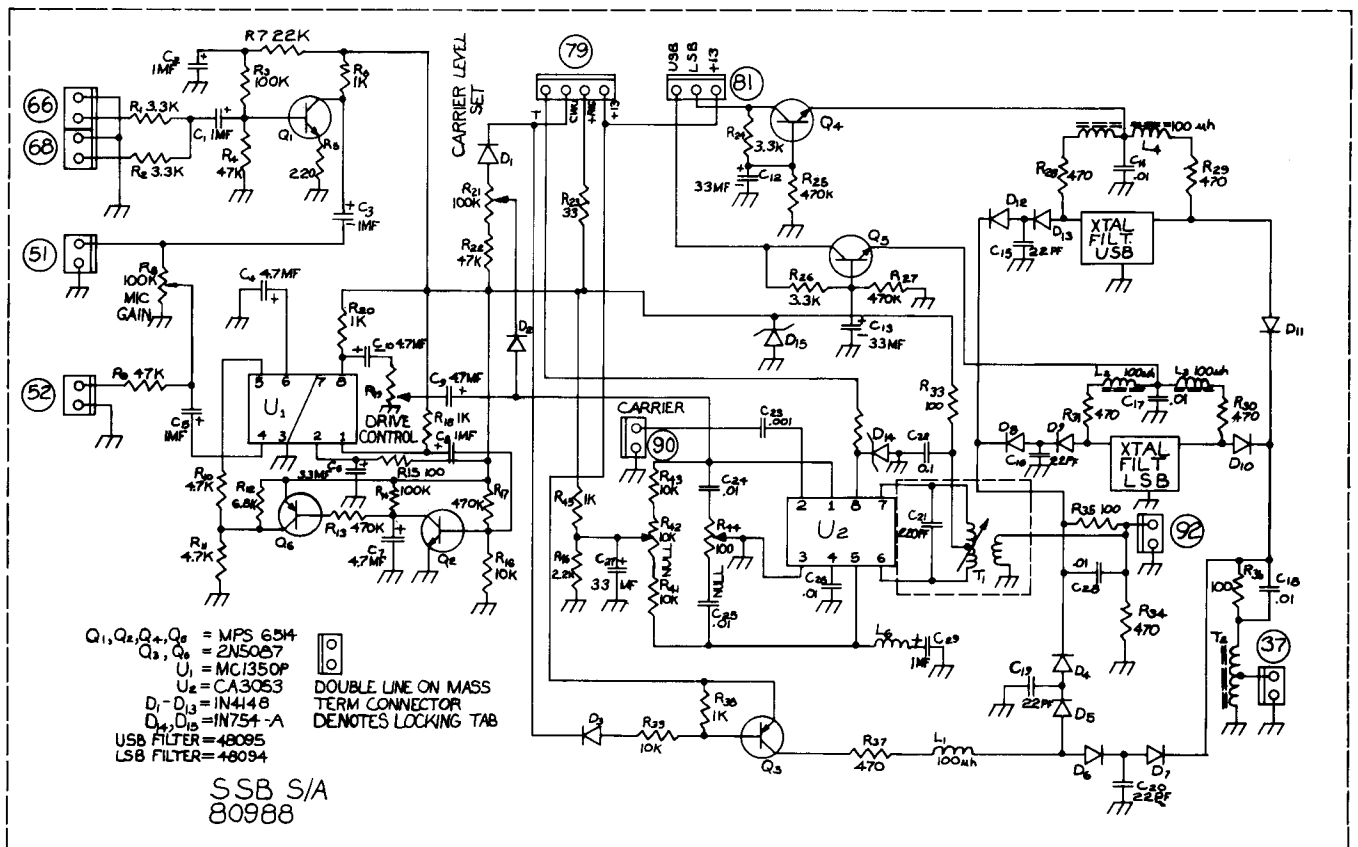

SSB Schematic

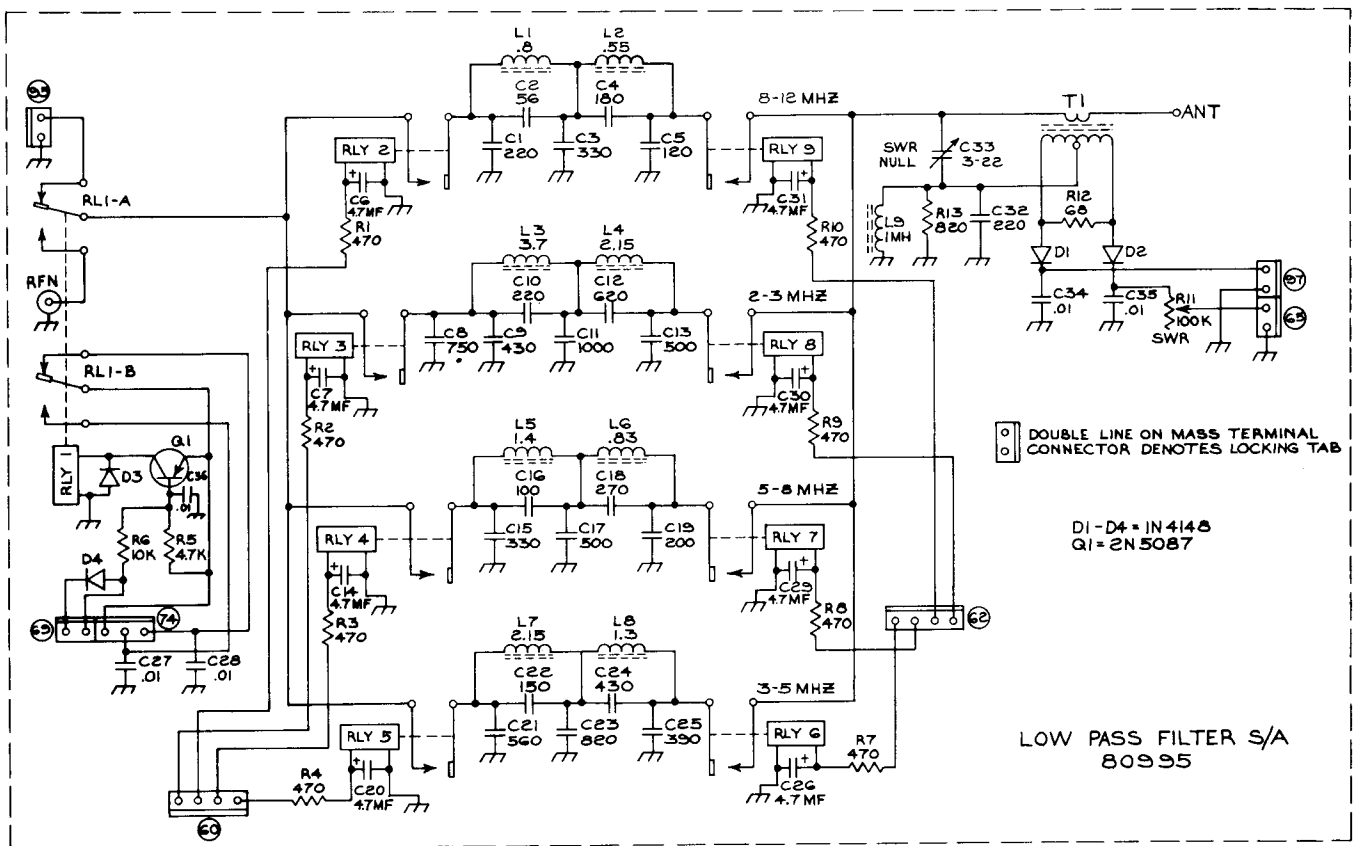
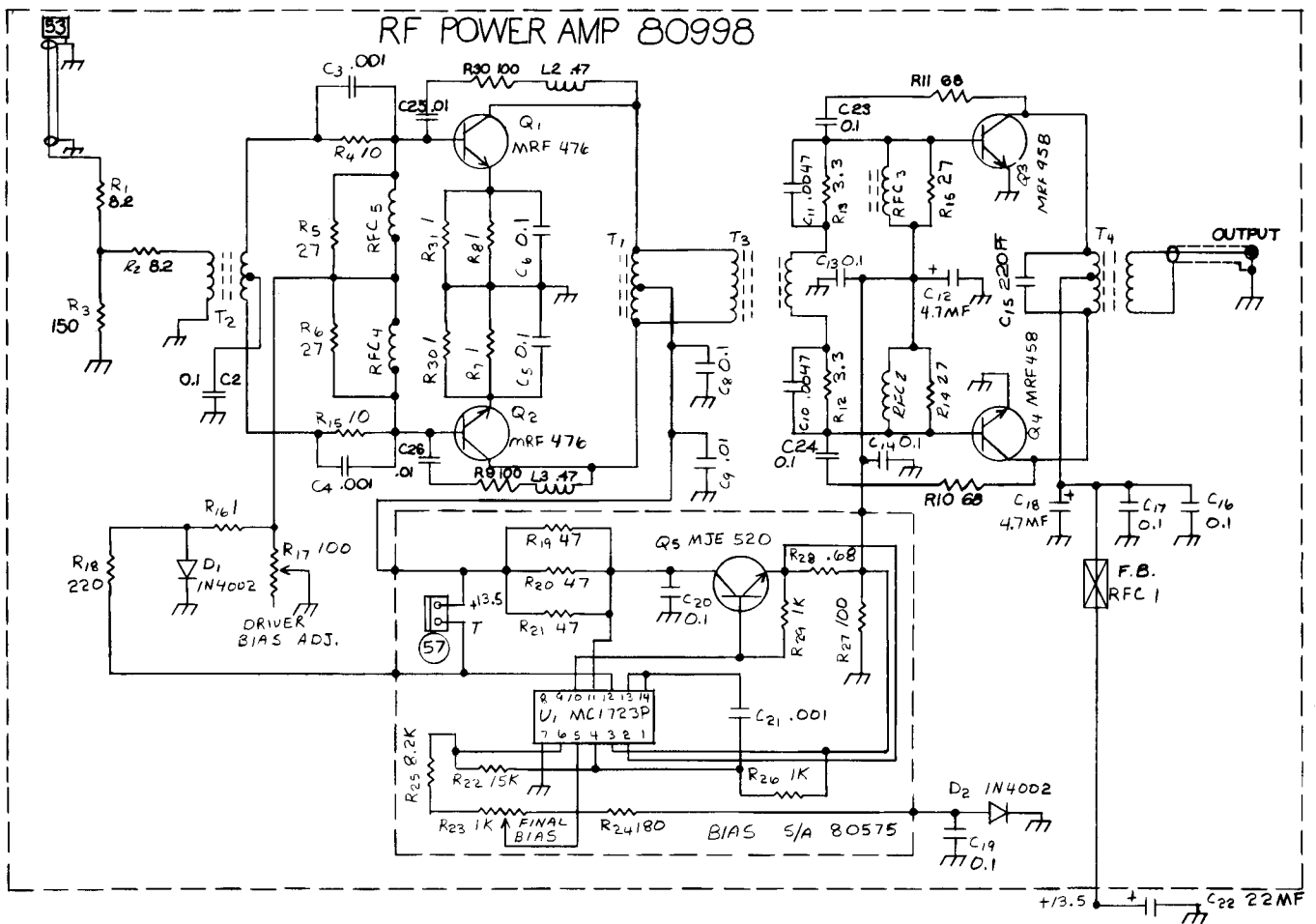

LOW PASS FILTERS Schematic

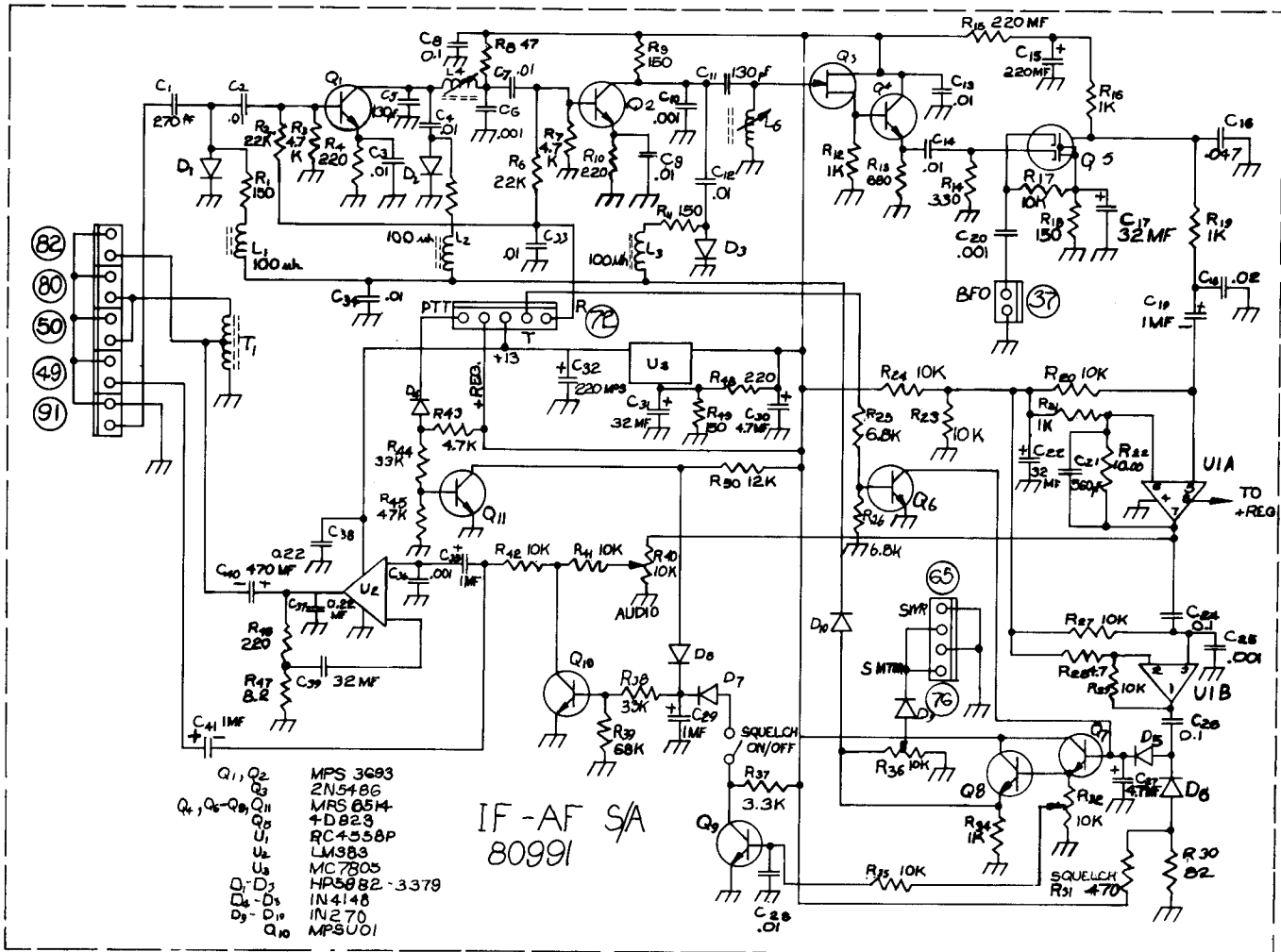

IF/AF Schematic

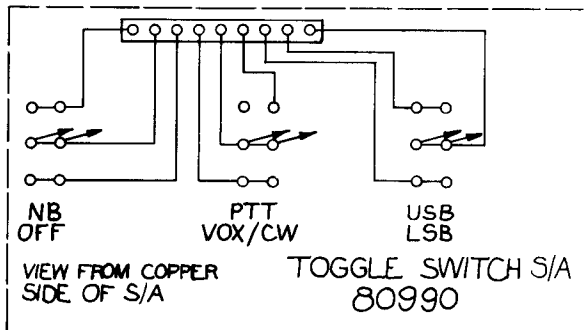

TOGGLE SWITCH Schematic

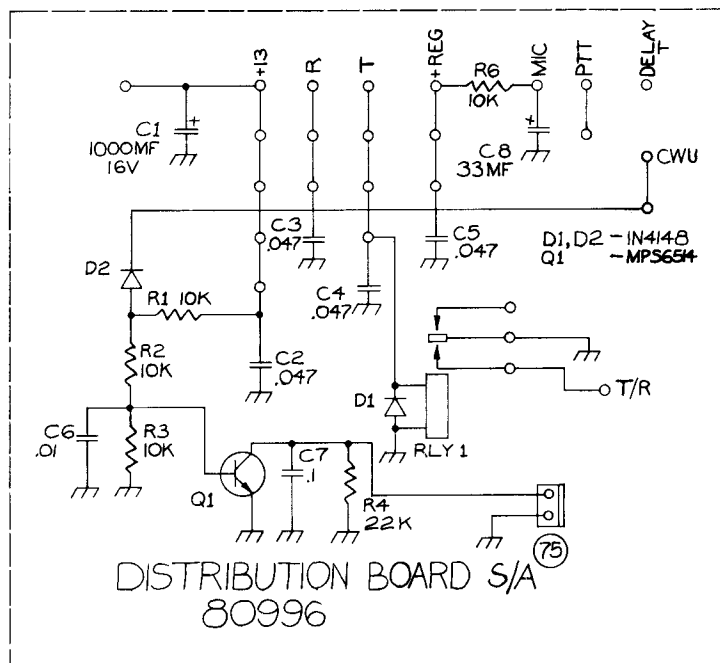

DISTRIBUTION BOARD Schematic

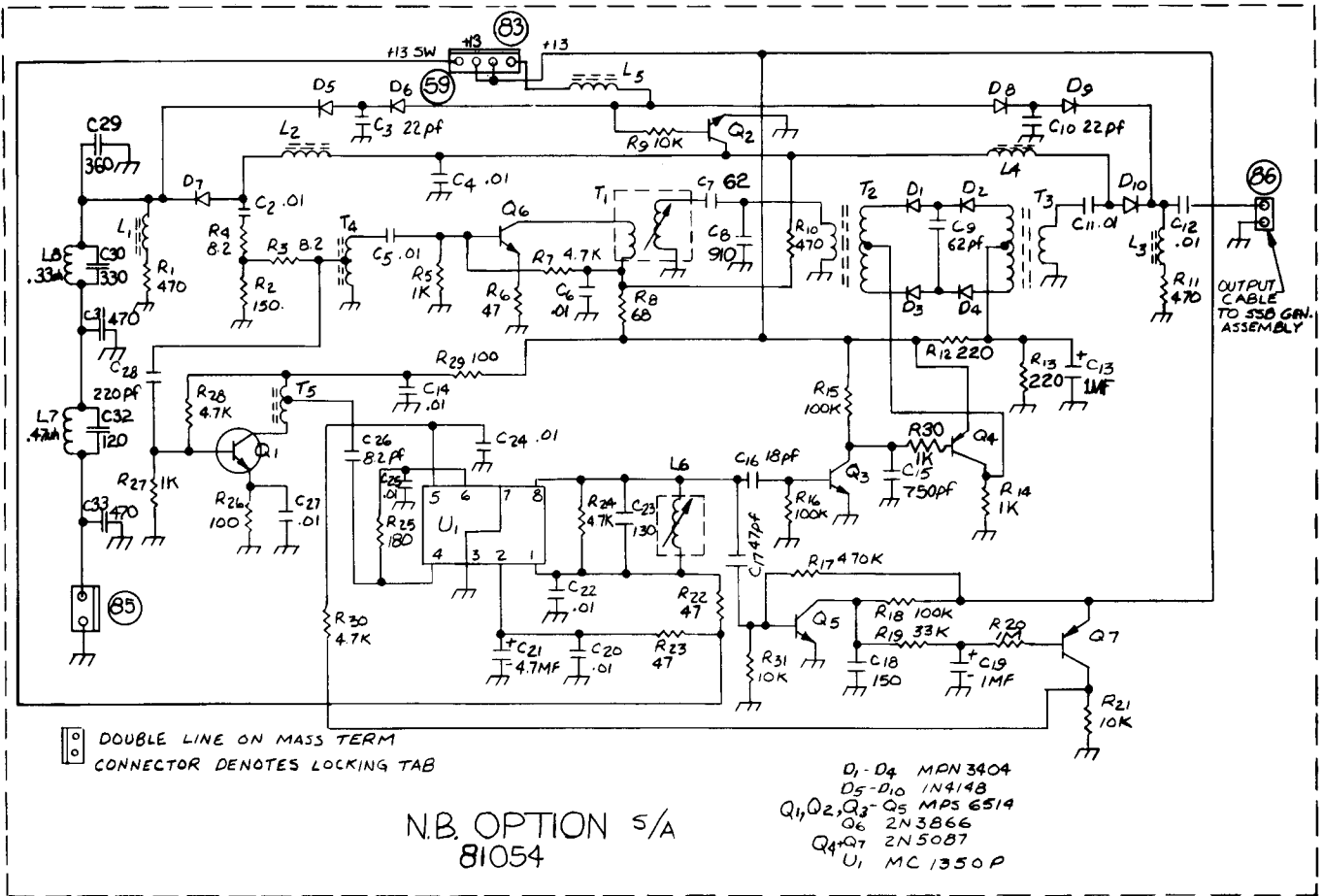

NB Option Schematic

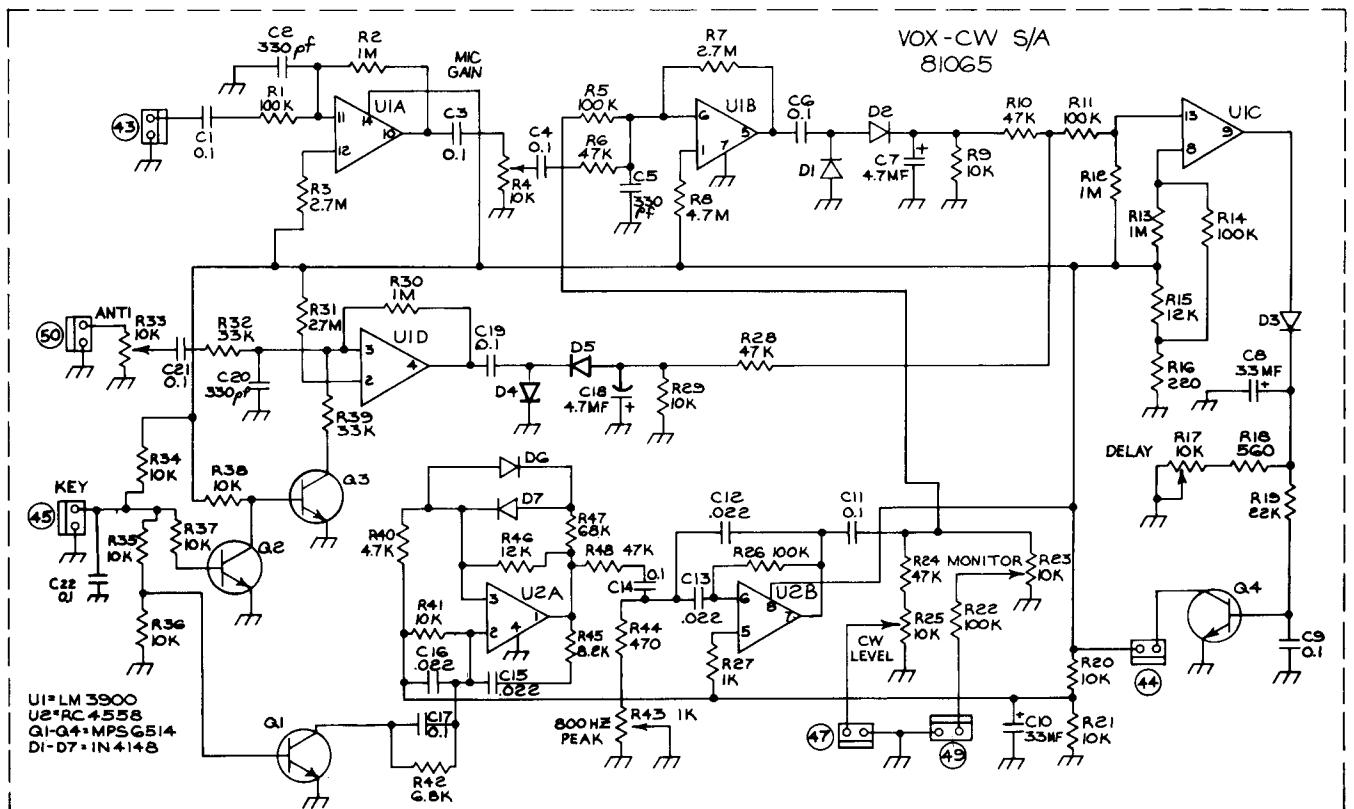

VOX Option Schematic

Pins Viewed From Top Of PC Board

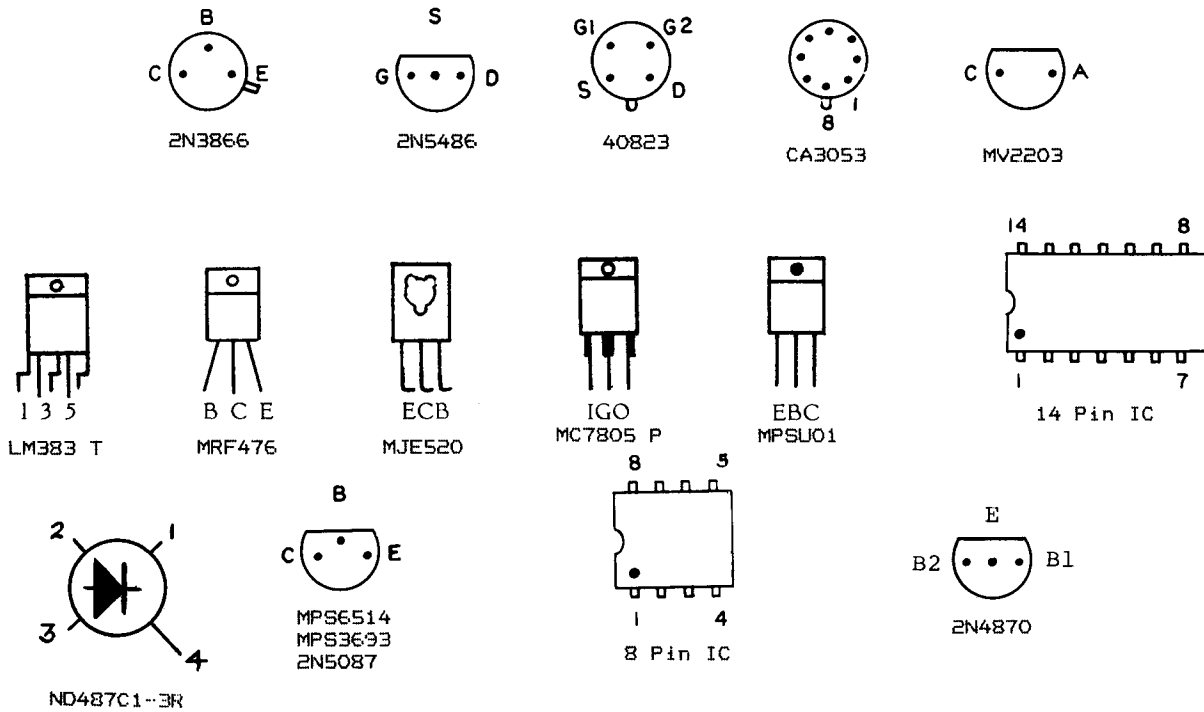

Figure 11 - Semiconductor Terminations

SPECIAL PARTS LIST

The list below contains all components used in the Model 150 Transceiver that are unique to it and not readily available except from TEN-TEC, Inc. It includes all transistors, diodes and integrated circuits, special trimmer capacitors and potentiometers, inductances and rf transformers, special panel controls and switches and some hardware items such as knobs, etc. Not included are components that are easily procured such as small fixed resistors, film, ceramic and electrolytic capacitors and miscellaneous hardware.

The list is grouped into the various PC assemblies and the main chassis and contains a description, part number and symbol used in the schematic drawing for easy reference.

TEN-TEC, Inc. offers the listed items as well as complete PC assemblies, metal parts and hardware items in four Spare Parts Kits. Contact your representative or TEN-TEC directly for kit details.

SSB - 80988

SYMBOL	DESCRIPTION	PT.NO.
D1-D13	Silicon Diode: 1N4148	28001
D14,D15	6.8 V Zener Diode: 1N754 A	28006
L1-L6	100 uHy RF Choke	21060
LSR	Lower Sideband Filter	48094
Q1,Q2,Q4,Q5	NPN Transistor: MPS6514	25054
Q3,Q6	PNP Transistor: 2N5087	25001
R8,R21	100 Kohm Trim Potentiometer	30198
R9,R42	10 Kohm Trim Potentiometer	30038
R44	100 ohm Trim Potentiometer	30071
T1	Bifilar RF Transformer	85208
T2	Bifilar RF Transformer	85120
U1	Integrated Circuit: MC1350 P	25062
U2	Integrated Circuit: CA3053	25024
USB	Upper Sideband Filter	48095

CARRIER OSC. - 80992

SYMBOL	DESCRIPTION	PT.NO.
C3	5-30 pF Trimmer Capacitor	23236
D1,D2	Silicon Diode: 1N4148	28001
D3	Varactor Diode: MV2203	28051
L1	100 uHy RF Choke	21060
Q1-Q5	NPN Transistor: MPS6514	25054
R4	10 Kohm Trim Potentiometer	30038
Y1	12.7 MHz Crystal	48093

LOW LEVEL AMP. - 80997

SYMBOL	DESCRIPTION	PT.NO.
D1,D2	PIN Diode: 5082-3379	28020
D3	5.6 V Zener Diode: 1N752 A	28011
D4,D5	Power Diode: 1N4002	28000
L1,L2	100 uHy RF Choke	21060
Q1	NPN RF Pwr Transistor: 2N3866	25027
Q2	NPN RF Pwr Transistor: MRF476	25081
Q3,Q4,Q5,Q8	NPN Transistor: MPS6514	25054
Q6,Q7	PNP Transistor: 2N5087	25001
Q9	FET Transistor: 2N5486	25060
R11,R15	10 Kohm Trim Potentiometer	30038
T1	Bifilar RF Transformer	85085
T2	Bifilar RF Transformer	85120

RF POWER AMPLIFIER/BIAS - 80998/80575

SYMBOL	DESCRIPTION	PT.NO.
D1,D2	PowerDiode: 1N4002	28000
Q1,Q2	NPN RF Pwr Transistor: MRF476	25081
Q3,Q4	NPN RF Pwr Transistor: MRF458	25080
Q5	NPN Pwr Transistor: MJE520	25002
R17	100 ohm Trim Potentiometer	30071
R23	1 Kohm Trim Potentiometer	30070
U1	Integrated Circuit: MC1723 P	25050

LOW PASS FILTERS - 80995

SYMBOL	DESCRIPTION	PT.NO.
C33	3-22 pF Trimmer Capacitor	23169
D1-D4	Silicon Diode: 1N4148	28001
L1	RF Inductance With Core	85209
L2	RF Inductance, Air	85110
L3	RF Inductance With Core	85231
L4,L7	RF Inductance With Core	85232
L5	RF Inductance With Core	85259
L6	RF Inductance With Core	85218
L8	RF Inductance With Core	85246
Q1	PNP Transistor: 2N5087	25001
R11	100 Kohm Trim Potentiometer	30198
RLY1	12 V DPDT Relay	32048
RLY2-RLY9	12 V SPST Reed Relay	32049
T1	Bifilar RF Transformer	85085

IF/AF - 80991

SYMBOL	DESCRIPTION	PT.NO.
D1,D2,D3	PIN Diode: 5082-3379	28020
D4-D8	Silicon Diode: 1N4148	28001
D9,D10	Germanium Diode: 1N270	28003
L1,L2,L3	100 uHy RF Choke	21060
L4,L6	1.25 uHy Inductance	21058
Q1,Q2	NPN RF Transistor: MPS3693	25032
Q3	FET Transistor: 2N5486	25060
Q4,Q6-Q9	Silicon Transistor: MPS6514	25054
Q11	Silicon Transistor: MPS6514	25054
Q5	FET Transistor: 40823	25022
Q10	NPN Pwr Transistor: MPSU01	25053
R32	10 Kohm Potentiometer/SPST	30211
R36	10 Kohm Trim Potentiometer	30038
R40	10 Kohm Potentiometer	30095
T1	Audio Transformer	80965
U1	Integrated Circuit: RC4558 P	25078
U2	Integrated Circuit: LM383 T	25099
U3	Integrated Circuit: MC7805 P	25095

XTAL OSCILLATOR - 80993

SYMBOL	DESCRIPTION	PT.NO.
C1-C8	5-30 pF Trimmer Capacitor	23236
D1-D8	PIN Diode: MPN3401	28052
L1-L11	100 uHy RF Choke	21060
Q1	NPN Transistor: MPS6514	25054
Q2	FET Transistor: 2N5486	25060
Q3	NPN RF Pwr Transistor: 2N3866	25027
T1	Bifilar RF Transformer	85120

TX-RX MIXER - 80989

SYMBOL	DESCRIPTION	PT.NO.
C3,C5	5-60 pF Trimmer Capacitor	23061
D1-D8	Silicon Diode: 1N4148	28001
D9	Diode Quad Mixer: ND487C1-3R	28053
L10-L19	100 uHy RF Choke	21060
L9	1.25 uHy Choke	21058
Q1,Q2	NPN RF Pwr Transistor: 2N3866	25027
T1,T2	12 MHz Trap Transformer	85233
T3,T4	Trifilar RF Transformer	85134
T5,T6	Bifilar RF Transformer	85120

BAND SWITCH - 80994

SYMBOL	DESCRIPTION	PT.NO.
D1-D17	Silicon Diode: 1N4148	28001
L1	100 uHy RF Choke	21060
Q1	PNP Transistor: 2N5087	25001
Q2,Q3	NPN Transistor: MPS6514	25054
Q4	NPN Pwr Transistor: MPSU01	25053

DISTRIBUTION BOARD - 80996

SYMBOL	DESCRIPTION	PT.NO.
D1,D2	Silicon Diode: 1N4148	28001
Q1	NPN Transistor: MPS6514	25054
RLY1	12 V SPDT Relay	32044

NB Option - 81054

SYMBOL	DESCRIPTION	PT.NO.
D1-D4	PIN Diode: MPN3404	28017
D5-D10	Silicon Diode: 1N4148	28001
L1-L5	100 uHy RF Choke	21060
L6	1.25 uHy Inductance	21058
Q1,Q2,Q3,Q5	NPN Transistor: MPS6514	25054
Q4,Q7	PNP Transistor: 2N5087	25001
Q6	NPN RF Pwr Transistor: 2N3866	25027
T1	RF Transformer	85214
T2,T3	Trifilar RF Transformer	85134
T4,T5	Bifilar RF Transformer	85120
U1	Integrated Circuit: MC1350 P	25062

VOX Option - 81065

SYMBOL	DESCRIPTION	PT.NO.
D1-D7	Silicon Diode: 1N4148	28001
Q1-Q4	NPN Transistor: MPS6514	25054
R4,R17,R23	10 Kohm Trim Potentiometer	30038
R25,R33	10 Kohm Trim Potentiometer	30038
R43	1 Kohm Trim Potentiometer	30070
U1	Integrated Circuit: LM3900 N	25068
U2	Integrated Circuit: RC4558 P	25078

MAIN CHASSIS

DESCRIPTION	PT.NO.
20 Ampere Fast Blo Fuse	27014
Power Diode: DSR1851-R, Press Fit	28009
Red Light Emitting Diode (LED)	28016
CLARIFIER Control: 10 Kohm Potentiometer	30226
Magnetic Circuit Breaker Assembly	81307
DPDT Toggle Switch	32023
CARRIER Pushbutton Switch	32026
Pilot Lamp: #1892	34011
PC Board Retainer	38078
Speaker	47004
Wing Nut, 10-32	54017
Plastic Cable Tie	77007
Round Knob	80536
Bar Knob	80539
Panel Meter	98026
PC Board Spacers	98078

24-150 1285

SPECIAL NOTICE

This Model 150 Transceiver is equipped with an electronic circuit breaker instead of the mechanical type that was previously used. The components are mounted on a small printed circuit board that is affixed to the ON/OFF switch. The entire unit mounts in the panel by means of the ON/OFF switch. In addition to the two red positive leads that were connected to the mechanical type breaker, an additional small ground lead is required between the PC board and chassis.

In operation the breaker is reset after tripping by cycling the switch to the OFF position and then back to the ON position. If the switch is left in then ON position and the source +12 volt line is opened, reapplying the +DC voltage WILL NOT reset the breaker. It will be necessary to cycle the ON/OFF switch to bring the transceiver into operation. The power-on condition is evidenced by illumination of the panel meter.

The breaker is designed to trip between 22 and 28 amperes with applied voltages between 11 and 14 volts DC. If the source voltage drops below 11 volts, the trip-out level will be reduced below 22 amperes. (If source voltage is sufficiently low, ON/OFF function will be disabled.)

If the breaker repeatedly trips after resetting, check these possible causes:

1. If breaker trips only after speaking into microphone, check antenna system for short circuit or high SWR.
2. If breaker trips only after speaking into microphone, check for low DC source voltage.
3. If breaker trips immediately after resetting, check for defective RF final amplifier, Pt.No. 80998/80575.

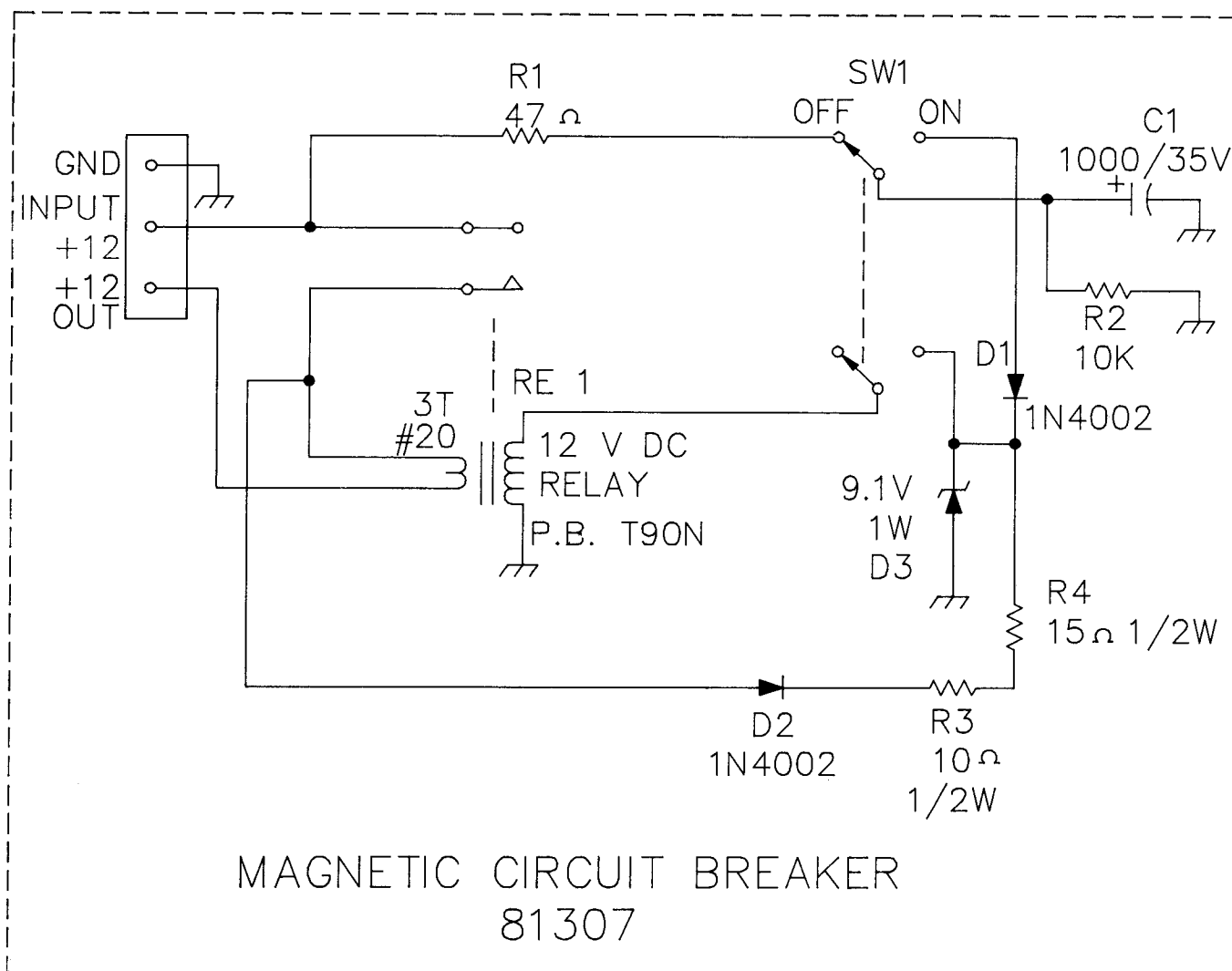

MAGNETIC CIRCUIT BREAKER Schematic