

**TEN - TEC**

**OWNER'S  
MANUAL**

**CENTURY/21  
DIGITAL  
MODEL 574**

CONTENTS

SECTION	TITLE	PAGE
I	INTRODUCTION	1- 1
	CONDENSED OPERATING INSTRUCTIONS	1- 1
	SPECIFICATIONS	1- 2
II	DETAILED OPERATING INSTRUCTIONS	2- 1
	Rear Panel Connections	2- 1
	Front Panel Controls	2- 2
	Full Band Coverage	2- 3
	Operating Hints	2- 3
	An Important Message	2- 4
III	ALIGNMENT AND SERVICE	3- 1
	Disassembly	3- 1
	Pilot Lamp Replacement	3- 2
	Fuse Replacement	3- 2
	Century Chassis	3- 2
	CHASSIS WIRING DIAGRAM	3- 4
	FIGURE 1 TOP VIEW	3- 6
	FIGURE 2 BOTTOM VIEW	3- 7
	FRONT END 80359	3- 8
	AUDIO PRE-AMP 80356	3-10
	AUDIO POWER AMP 80357	3-12
	PTO 80278	3-14
	DIGITAL READOUT	3-16
	Theory of Operation	3-16
	Servicing Hints	3-17
	Wiring Code	3-19
	Logic Board 80397	3-20
	Bandswitch Assembly 80399	3-21
	MIXER 80358	3-22
	LOW LEVEL DRIVER 80354	3-26
	FINAL AMPLIFIER 80361	3-28
	LOW PASS FILTER 80360	3-30
	CONTROL BOARD 80355	3-32
POWER SUPPLY 80353	3-34	
WARRANTY AND SERVICE POLICY	Insert	

Pt. No. 74078  
3/78

## SECTION I

## INTRODUCTION

The Model 574 is a versatile medium power cw transceiver employing the latest techniques in solid state technology. Unique balun type transformers couple each stage in the rf sections, insuring efficient energy transfer without the need for resonating or peaking controls on the front panel. Individual low pass output filters for each band and a Class C push-pull final amplifier reduce transmitted harmonic and TVI radiation to a low value.

As you become more familiar with the operation of your Model 574 you will value the built-in operating conveniences more and more. The broad-band circuitry completely eliminates transmitter tune-up when changing bands or moving from accidental antenna short circuit or operator error. The instant break-in feature, which allows incoming signals to be heard between transmitted characters, is a luxury enjoyed by only a few cw operators, but desired by all. It changes cw contacts from a series of monologues into conversation.

The receiving section is designed around a unique Double Direct Conversion circuit with performance comparable to the conventional superheterodyne. This approach provides frequency stability and bandsread characteristics which are the same for all bands. The ZERO BEAT feature allows precise setting of the transmitter frequency to the incoming station, and a three position SELECTIVITY control effectively separates closely spaced stations. All in all, the Model 574 is designed for pleasurable cw operation for the beginner and old timer alike.

## CONDENSED OPERATING INSTRUCTIONS

The following instructions will enable the operator to replace the Model 574 quickly into operation. For a more detailed description of the controls and their functions, refer to SECTION II.

REAR APRON CONTROLS

POWER - Connect line cord to a source of 105-125 VAC, 50-60 Hz.

ANTENNA - Connect a 50 to 75 ohm, unbalanced resonant antenna, such as a beam, dipole or vertical. Balanced, long wire and similar antennas with higher input impedances should be used with an antenna tuner to provide a reasonable match (SWR) to 50 ohms.

KEY - Connect a straight key, bug or electronic keyer to this jack. Electronic keyers preferably should have a reed relay or a positive voltage, low saturation transistor output circuit, such as is employed in the TEN-TEC Model 670 Century Keyer.

GND - To reduce the possibility of stray rf pickup on interconnecting cables, which may cause parasitic oscillation, all station equipment should be well grounded to earth. This also reduces possibility of electrical shock, and provides some lightning protection. Connect a short, heavy lead, preferably shield braid, between chassis lug on the rear panel and a good earth ground.

FRONT PANEL CONTROLS

## INITIAL CONTROL SETTINGS

- 1.) Select desired band with BAND switch. If working the 28.5-29.0 MHz band, the accessory crystal must be installed. See instructions furnished with this crystal for proper installation.
- 2.) Set DRIVE control fully counter-clockwise (CCW).

1-2

- 3.) Apply power by actuating POWER ON-OFF switch located on RF GAIN control. This is a push-pull switch. Pilot lamps should illuminate and LED Digital Display should be on.
- 4.) Tune dial to desired frequency within selected band.
- 5.) Push SET DRIVE button and advance DRIVE control until power meter indicates 70 watts input power. Release button. Transceiver is now ready for operation.
- 6.) The power supply in the Model 574 is equipped with an automatic current limiting shutdown circuit. If DRIVE control is set too high, or if the antenna should suddenly become disconnected or shorted, excessive current drain will turn the unit off. To reset, make sure cause of the overload is corrected, turn down the DRIVE control and then cycle the POWER ON-OFF switch. Panel lights will come on and normal operation may be resumed.

#### SPECIFICATIONS

##### GENERAL

FREQUENCY COVERAGE - 3.5 to 4.0; 7.0 to 7.5; 14.0 to 14.5; 21.0 to 21.5; 28.0 to 28.5; 28.5 to 29.0 MHz. (Crystal not supplied for 28.5 to 29.0 MHz, but available as accessory, Model 273.)

VFO FREQUENCY STABILITY - Less than 20 Hz change per degree Fahrenheit, averaged over a 40° change from 70° to 110°, after 30 minute warmup. Less than 20 Hz change from 105 to 125 VAC line voltage.

TUNING RATE - Approximately 17 kHz per revolution of main tuning knob.

POWER REQUIREMENTS - 105-125 VAC, 50-60 Hz. 15 watts receive, 115 watts transmit.

SEMICONDUCTORS - 28 transistors, 37 diodes, 11 integrated circuits, 5 seven segment LED displays.

PC BOARDS - 4 plug-in types, 9 integral.

CONSTRUCTION - Rigid aluminum chassis and sub-panels. Aluminum case. Grey front panel, black textured vinyl cover.

DIMENSIONS - HWD 6-1/8" x 12-1/2" x 12-1/2".

WEIGHT - 16 lbs.

##### RECEIVER

SENSITIVITY - 1 uV or less for 10 dB S+N/N.

SELECTIVITY - Three position; 0.5, 1.0 and 2.5 kHz.

VFO FREQUENCY - 5.0 to 5.5 MHz. Double Direct Conversion.

ANTENNA INPUT - 50 ohms, unbalanced.

AUDIO OUTPUT - 1 watt @ 8 ohms, less than 2% harmonic distortion. Built-in speaker; PHONES jack.

OFFSET TUNING - Approximately  $\pm$  5 kHz, defeatable with ZERO BEAT switch.

##### TRANSMITTER

DC INPUT POWER - 70 watts.

RF OUTPUT POWER - 25-30 watts, typical.

OUTPUT IMPEDANCE - 50-75 ohms, unbalanced.

T/R SWITCHING - Full break-in cw with PIN diode switch.

CW SIDETONE - Internally generated; adjustable level.

METER - Indicates total dc power drawn from supply.

FRONT PANEL CONTROLS

Receiver RF GAIN; receiver AF GAIN; ZERO BEAT switch; SET DRIVE switch; DRIVE; OFFSET; BAND switch; SELECTIVITY switch, three position; Main tuning knob; POWER ON-OFF switch; PHONES jack.

REAR APRON CONNECTIONS

ANTENNA jack; XTAL CAL jack; AUX 12 VDC jacks (2); KEY jack; GND lug; line cord.

## SECTION II

## DETAILED OPERATING INSTRUCTIONS

## REAR PANEL CONNECTIONS

ANTENNA

Any unbalanced antenna presenting 35 to 75 ohms impedance to the unit will work satisfactorily. This represents a SWR of 1.5 to 1 or less. When using random length antennas or open wire feed systems, a matching network should be used to obtain an equivalent impedance.

An unbalanced antenna is one which has a feed point with one of the two terminals at ground potential. The transmission line in this case is usually of the co-axial type, with the outer shield connected to the ground potential terminal. Balanced antennas have both feed terminals above ground potential. These can be converted into an unbalanced feed configuration by either inserting a balun between the feed point and the transceiver (at antenna, transceiver or anywhere in transmission line), or an antenna tuner designed to accept balanced loads and unbalanced inputs. Further information on this subject is available from the many antenna handbooks.

GROUND

To reduce possibility of stray pickup on interconnecting cables, all station equipment should be well grounded to earth. This is especially important when using high impedance antennas and matching networks, where the rf voltage levels are necessarily high.

KEY

The key actuates a series of circuits on the CONTROL BOARD assembly that supplies operating voltages to various transmitter and receiver circuits. When the key is closed, the receiver is disabled and operating bias is applied to the transmitter. At the same time the antenna is electrically isolated from the receiver input. There is a short time delay in the audio muting circuit to eliminate clicks in the speaker when keying. It is not long enough to interfere with the full break-in feature of the unit. Sidetone volume is independent of the audio gain control and is adjusted with a printed circuit thumbwheel potentiometer, accessed through a hole in the bottom cover.

For proper operation, the key line requires a very low resistance path to chassis, with no appreciable voltage across it. Hence, electronic keyers with reed relays, or transistor switched circuits incorporating low saturation NPN transistors are recommended. Improper key line conditions may cause lower than rated power output, improper keying envelope and/or key clicks. TEN-TEC Model 670 Century Keyer is designed specifically for use with the unit.

AUX 12 VDC

These two jacks may be used to power external equipment such as an electronic keyer. They are connected to the +12 volt regulated supply in the unit and hence will show as additional WATTS INPUT on the panel meter. The full six amperes can be drawn from these jacks, with full regulation, but any power taken from these jacks reduces that available for the transmitter. For every ampere drawn from the jacks, the actual input power to the final amplifier will be reduced by approximately 12 watts. (Model 670 keyer only requires a small fraction of an ampere.)

For mobile or portable operation using an external 12 VDC power source, power may be supplied to the unit through either of the two AUX 12 VDC jacks. Be certain that polarity is NEG GND. As the protective circuitry for the final is by-passed when using an external power source, install Model 1170 Circuit Breaker in series with the power source. When operating with an external power source, the front panel ON/OFF SWITCH and INPUT METER are rendered inoperative. In order to set DRIVE control to circuit breaker trip out, and back off slightly.

XTAL CAL

This socket is provided for use with Model 276 Crystal Calibrator. Refer to main schematic for pin connections.

## FRONT PANEL CONTROLS

POWER ON-OFF

The POWER ON-OFF switch is located on the RF GAIN control. It is a push-pull type. In addition to the on-off function, it is used to reset the power supply when it shuts down from overload. To reset, simply re-cycle the switch, after removing the cause of the overload (usually DRIVE control set too high).

BAND SWITCH

The BAND switch selects the desired 500 kHz band of operation. The 28.5 position can be used with an optional crystal for additional coverage in the ten meter band. The crystal frequency for this operation should be 5.0 MHz less than the lower edge of the 500 kHz segment to be covered in the ten meter band. For example, to cover 29 to 29.5 MHz, obtain a crystal for 24.0 MHz. The crystal used should be parallel resonant type, 32 pf load, with a fundamental cut in a HC-25/U case.

MAIN TUNING

The main tuning knob simultaneously adjusts both receiver and transmitter frequency. The operating frequency is displayed to the nearest kHz on the 5 digit LED readout. Clockwise rotation increases frequency on 14, 21 and 28 MHz bands and decreases frequency on 3.5 and 7 MHz, due to the mixing scheme used in the transceiver.

OFFSET

The OFFSET control tunes the receiver independently of the transmitter by approximately  $\pm 5$  kHz. This feature is useful when several stations are being worked in a round-table, and all are not exactly on the same frequency. The received stations can be zeroed in with the OFFSET control without upsetting the transmitter frequency. Also, it is very useful in working DX where the DX station is working stations slightly off his frequency.

Since a station can be received on either side of the zero beat position, an interfering station slightly removed from the desired one may be completely eliminated by tuning the OFFSET control to the opposite side of zero beat.

ZERO BEAT

Pushing the ZERO BEAT button in defeats the OFFSET control and allows the operator to set the transmitter exactly on the received station's frequency. This is accomplished by tuning the incoming signal to zero beat, i.e. to where the received tone goes down to inaudibility, while depressing the ZERO BEAT button. The signal should be heard on either side of this setting, rising in pitch as you proceed further away. Releasing the button, the signal can then be set for the most pleasing pitch with the OFFSET control.

SELECTIVITY

Three positions of selectivity are available:

- 2.5 kHz for ssb or general cw listening.
- 1.0 kHz for cw or ssb with QRM.
- 0.5 kHz for cw on crowded band.

RF GAIN

The RF GAIN control is a potentiometer in the receiver antenna line. It operates as an attenuator to reduce the susceptibility to overload in the presence of extremely strong signals.

AF GAIN

The AF GAIN controls the input level to the audio amplifier. It should be adjusted for a comfortable audio level in the speaker or headphones.

SET DRIVE

This push-button switch is in parallel with the key line and places the transceiver in the transmit mode. It is used while adjusting DRIVE control to the desired input power level of between 60 and 70 watts, as indicated on the panel meter.

DRIVE

The control sets the level of rf applied to the final amplifier. For full rated input, it is set to provide a meter reading between 65 and 70 watts. Increasing drive beyond this point will trip the electronic circuit breaker. It is possible, when the unit is powered on while in the transmit mode and the DRIVE control is set to 70 watts, that the turn-on transient current surge will trip the circuit breaker. Either turn DRIVE control down or make sure the transmitter is not keyed on before attempting to turn the unit on.

PHONES

The PHONES jack is provided for an external speaker or for headphones. When in use, the internal speaker is automatically disconnected. The amplifier output is designed for an 8 ohm load but will operate satisfactorily with high impedance phones or speakers with 4 to 16 ohms impedance. When using low impedance phones, it is recommended that an attenuating network be used. When transmitting, residual noise and audio feedthrough will be reduced. A simple resistor network consisting of approximately 15 ohms in series with the phones and a shunt resistor of 2.7 or 3.3 ohms across the phones should suffice.

FULL BAND COVERAGE

The unit as shipped from the factory has crystals installed for operation on all bands except 28.5 to 29.0 MHz. The additional crystal (Model 273, Pt. No. 38027) is available to cover this range. To install this crystal, place unit upside down, remove bottom cover screws (6) and carefully lift cover off. Exercise caution so that leads going to speaker are not stressed. The crystal is inserted into the socket provided on the mixer board. (Refer to Fig. II, Section III.)

OPERATING HINTS

1. The speaker is most effective when the unit is placed on a hard surface and the two front snap-up legs are extended. With legs down, adequate sound quality is still produced when the unit rests on a hard surface.
2. When setting up the station, provide adequate ventilation for the heat sinks on the unit. Do not confine unit to a small volume without forced ventilation to circulate cool air around the heat sink.
3. The unit may be operated as a QRPp transceiver simply by adjusting DRIVE control downward.
4. Sidetone level control is accessible through finger hole located in bottom plate.
5. The VFO oscillator in the unit, like any LC tuned oscillator, is adversely affected by ac magnetic fields cutting the coil turns. The oscillator output is frequency modulated at the line frequency, causing a "dirty" cw note and/or poor SSB quality in both transmit and receive modes. When installing the unit, locate any ac operated equipment which may generate magnetic fields, such as power supplies, electric clocks, keyers, rotator controls and other station accessories, as far as possible from it. Since the VFO is located front and center, the most common cause of FMing is from placing these accessories on top of the unit. However, large power supplies may cause interference even when placed adjacent to the transceiver. A check of the purity of a received cw signal should be made at the time of installation.

6. Due to the possibility of high voltage transients being generated in the output rf amplifier during band switching, changing bands should not be done while transmitting power to the load. Either place the transceiver in the receive mode or be certain of a "key up" condition. YOU RISK THE POSSIBILITY OF DESTROYING THE OUTPUT TRANSISTORS IF THIS PRECAUTION IS NOT OBSERVED.
7. Although improper antennas will not damage the unit, we suggest an SWR below 2 to 1 be achieved for maximum performance. In cases where the antenna cannot be matched to a better SWR, and the power supply repeatedly shuts down due to over-current conditions, the unit can be operated at reduced input power by rotating the DRIVE control counterclockwise to a position where the supply does not trip out.

#### AN IMPORTANT MESSAGE TO ALL OWNERS

In order for you to attain top performance from your transceiver, we feel that you should be briefed on all new information that comes to us from the field regarding the installation and operation of these units. Also, especially in the case of new technology such as solid state no-tune rf amplifiers, misconceptions sometimes arise from incomplete knowledge which result in erroneous conclusions being drawn that the equipment is faulty, erratic or not performing to specifications. There are sufficient units now in the field to indicate to us that there are several rather serious information gaps in these areas. It is the purpose of this letter to fill in these gaps so that you can knowledgeably approach and correct any apparently improper performance characteristics of the unit.

The main field concern appears to be a matter of fundamental technical knowledge regarding SWR, efficiency and power supply overload protection.

Before presenting a detailed explanation regarding this information gap, a summary of ten points to be aware of when installing the unit is given below. The reasons and technical background for these observations are explained thoroughly in the paragraphs below.

#### Ten Points to Observe When Installing the Unit

1. The unit will give best performance when properly loaded.
2. Even though the output transistors are resistant to damage from improper loads, they will not operate satisfactorily under all load conditions.
3. The output transistor dissipation will increase if not properly loaded.
4. Reactive impedance components in the antenna are applied to the transistors and may cause parasitic oscillations.
5. A given SWR reading does not tell you anything about the reactive components and is not accurate unless the load is a pure resistance.
6. A given SWR indicates one of two possible impedances. Each acts differently on the transceiver performance.
7. The most efficient operating point is when the load is 50-75 ohms, resistive.
8. The meter is not an indication of output power, but the input power.

9. If the breaker repeatedly trips, it is an indication that the load is enough removed from optimum so as to cause high transistor dissipation.
10. It is possible for the power supply regulator to drop out of regulation just prior to its tripping the breaker. Under these conditions, hum modulation will appear on the transmitted signal. With proper load the unit current drain will be considerably below the tripping point, so no hum should appear when operating properly.

#### On the Matter of Performance Claims

Our literature makes the statement that the unit will not be damaged from off-resonance operation or when using the wrong antenna, or even with no antenna or one that is short circuited. Notice that we do not say that it will perform to specifications under these conditions, or that it may not go into parasitic oscillation. In order to meet our published specifications, the antenna impedance should be between 50 and 70 ohms. However, satisfactory operation may be attained in many cases with antennas giving as much as 3 to 1 SWR. It all depends on the nature of the impedance and how it relates to the ten points of observation listed above. In the technical discussion below, you will be given the symptoms to look out for which indicate that the antenna match needs improving.

#### Technical Facts of Life

Although vacuum tubes and transistors both can be made to amplify rf power, there are some fundamental differences in how this is accomplished. We are all familiar with vacuum tube principles, but not with those of transistors. A better understanding of what we can expect under various operating conditions will aid in recognizing correct or incorrect performance.

1. Broadband vs Resonant Tanks—Almost all tube circuits use resonant tanks in the plate circuit. The unit uses a broadband system. In class C operation these two approaches act similarly without drive being applied. The idle current is zero, even with load impedance variations from open to short circuit.

However, with drive applied, the two act very differently. In the case of tubes, the dissipation within the tube depends on both the tuning of the tank and the load applied. If the tank is resonated, and the load is very light, the internal power dissipated is quite small, as indicated by the null which reduces plate current almost to the level with no drive. Out of resonance, the plate current and hence dissipation increases rapidly and may damage the tube from overheating. In resonance, as the load is increased, the null becomes more shallow at a higher plate current, as a result of the power being delivered to the load. As the tank is tuned to resonance, the load impedance, which is usually on the order of 50 ohms, is transformed to a relatively high impedance of several thousand ohms to match the plate current impedance. Small load reactive components--either capacitive or inductive--can usually be balanced out in the tank resonating function.

With transistors, drive applied and no load, there is no resonant high impedance to limit the collector current, and so power is poured into the circuit (much as the out-of-resonance tank conditions). Since there is no load power, all has to be dissipated in the transistor. So even with no load, the power supply circuit breaker may trip. The broad-band transformer system used with transistors transforms the 50 ohm load impedance not higher, but much lower (in order of 4 or 5 ohms) to match the transistor output impedance. Since this transformation is fixed in design, any reactive component in the load

impedance is applied in a transformed way to the collector circuit. Certain reactances at this point, especially inductive, give rise to parasitic oscillation. To correct for this, the antenna impedance should be changed to remove this reactance, or a matching network should be inserted between antenna and transceiver. It is important to remember that any antenna changes its impedance with frequency, so one that resonates well at one end of the band may well cause oscillations or trip the circuit breaker on the other end. If entire band operation is desired, especially on 80 and 40 meters, the adjustable matching network approach would be the better choice, rather than try to make the antenna behave over the entire band on a cut-and-try basis.

A final point to bring out regarding broadband vs tank systems is that there is a limit to the amount of current you can draw from an emitting filament and this saturation current will limit the amount of power drawn from the supply. In the case of transistors, where the collector internal impedance is only a fraction of an ohm, extremely high currents can be demanded of the power supply, especially with mismatched loads well below 50 ohms.

2. SWR - Two Kinds - The standing wave ratio is a direct measure of the ratio between two impedances, i.e. an SWR of 3 to 1 tells us that one impedance is three times the other. Therefore, the unknown impedance can be either three times as large or three times as small as the known one. If the desired impedance that the transceiver wants to see is 50 ohms, a SWR of 3 to 1 on the line may mean a load impedance of either 150 ohms or one of 17 ohms. If it is 150 ohms, the transmitter will act differently than if it is 17. In the first case, the power demanded from the supply will be much lower, and will not be large enough to trip the supply. In the second case, even though the SWR meter reads the same, the supply may repeatedly trip out. The SWR reading gives no indication of reactive components, nor can it separate the resistive from the reactive components. It is calibrated with a pure resistive load and therefore has its greatest accuracy with pure resistive loads. The SWR bridge only should be used as an indicator when attempting to adjust the antenna system to a pure 50 ohm resistive impedance.
3. Efficiency - Since transistor amplifiers have a very low value of output impedance, they act more or less as a constant voltage source. That is, the rf output voltage tends to remain at a fixed value regardless of the load impedance. Hence, the output power will vary depending on the value of load and increase as the load impedance goes down. It can be seen that a 3 to 1 SWR on the low side of 50 ohms will ask the amplifier to deliver much more power than a 3 to 1 SWR on the high side. Since the amplifier does have a finite value of output impedance, the amount of power delivered to the load with efficiency, will change with load. Unless the load is near the design value, the transistors will heat up unnecessarily without delivering any more power to the antenna.

If the above precautions are observed, we are sure that you will be more than delighted with the performance of your unit.

#### Recommended Reading

1. ARRL Antenna Handbook
2. Antenna Handbook, Ken Glanzer, Cowan Publishing Co.
3. W8NWU Teeter Totter Tuners, Schultz, CQ Feb. '69. Page 27

## SECTION III

## ALIGNMENT AND SERVICE

This section is subdivided into description of the main chassis and each plug-in assembly. Pin and transistor voltages are given for each unit. Readings should be within 15% of listed values when measured with a dc voltmeter with at least 20,000 ohms-per-volt impedance. All readings are dc and positive with respect to chassis GND unless stated otherwise. Plug-in pin locations are in the same relative positions on the assemblies as noted on the schematics. In other words, if the assembly is placed component side up on the schematic in the same position as shown in the photograph, the individual pin functions are the same as those noted on the schematic.

When removing a plug-in assembly, note the orientation of the board in the chassis so it can be replaced correctly. Some assemblies can be inadvertently inserted incorrectly if care is not taken. Figures 1 and 2 show correct placements.

To remove a plug-in assembly, first remove the screws holding the board to the sockets and any screws or nuts securing single socket boards. Then, with long nose pliers, work the assembly straight up out of the socket or sockets by pulling on the end pins in sequence.

To facilitate location of the various components that may require adjustment or alignment, refer to the table below.

<u>Function</u>	<u>Assembly</u>
Receiver i.f. Amplifier	Front End, 80359
Receiver r.f. Coils	Mixer, 80358
Offset Zero Adjust	Control Board, 80355
Sidetone Level	Audio Pre-Amp, 80356
Driver Bias Set	Final Amplifier, 80361
Meter Calibration	Power Supply, 80353
Power Supply Trip Adj.	Power Supply, 80353
Counter Timebase Adj.	Logic Board, 80397

## DISASSEMBLY

Removal of Top

Remove the upper two screws on each side. Lift the top off.

Removal of Bottom

Remove four screws holding speaker grille. Feed speaker down through cutout, using notches in cutout to clear outer edge of speaker. Remove the remaining six screws - two on bottom, two on each side.

Removal of Front Panel

First remove top and bottom, Remove BAND switch knob using a small flat-bladed screwdriver. Then remove the main tuning knob and SELECTIVITY knob using 4-40 Allen wrench provided. The remaining knobs pull straight off. It may be necessary to pry them off with a flat-bladed screwdriver. Protect the front panel from scratches using a piece of cloth or cardboard under the driver. Remove the PHONES jack using a 1/2-inch wrench. Unsolder the wires to the ZERO BEAT, SET DRIVE and METER. Note and record polarity on meter leads. Using a 1/2-inch socket, remove the four control nuts from the OFFSET, DRIVE, RF GAIN and AF GAIN controls. Pull the panel forward and remove.

## PILOT LAMP REPLACEMENT

The panel lamp is a 14 volt, bayonet type, No. 1813 or 1892. Access to this bulb is by removing top of unit.

## FUSE REPLACEMENT

The fuse is located inside the bottom. Replace with a 2A SLO-BLO.

## CENTURY CHASSIS

The chassis wiring is color coded.

Color	Function	Voltage	
		TRANSMIT	RECEIVE
Black	Ground	0	0
Brown	OT POT	0	2.5
Red	+12	12.5	12.5
Orange	OT ON-OFF	12.5	0
Yellow	OT POT	0	4.3
Green	OT POT	3.0	5.8
Blue	T	10.5	0
Violet	DRIVE	*	0
Gray	METER	-.1	0
White	+9 reg.	8.9	8.9
Brown-White	SIDETONE	0	0
Red-White	KEY	0	4.5
Orange-White	OT	3.8	#
Yellow-White	XTAL Cal.	0	0
Green-White	+23v	18*	23.0
Blue-White	R	0	11.0
Gray-White	BASE Q1	13.2	13.2

\*Depends on DRIVE setting

#Depends on OFFSET setting

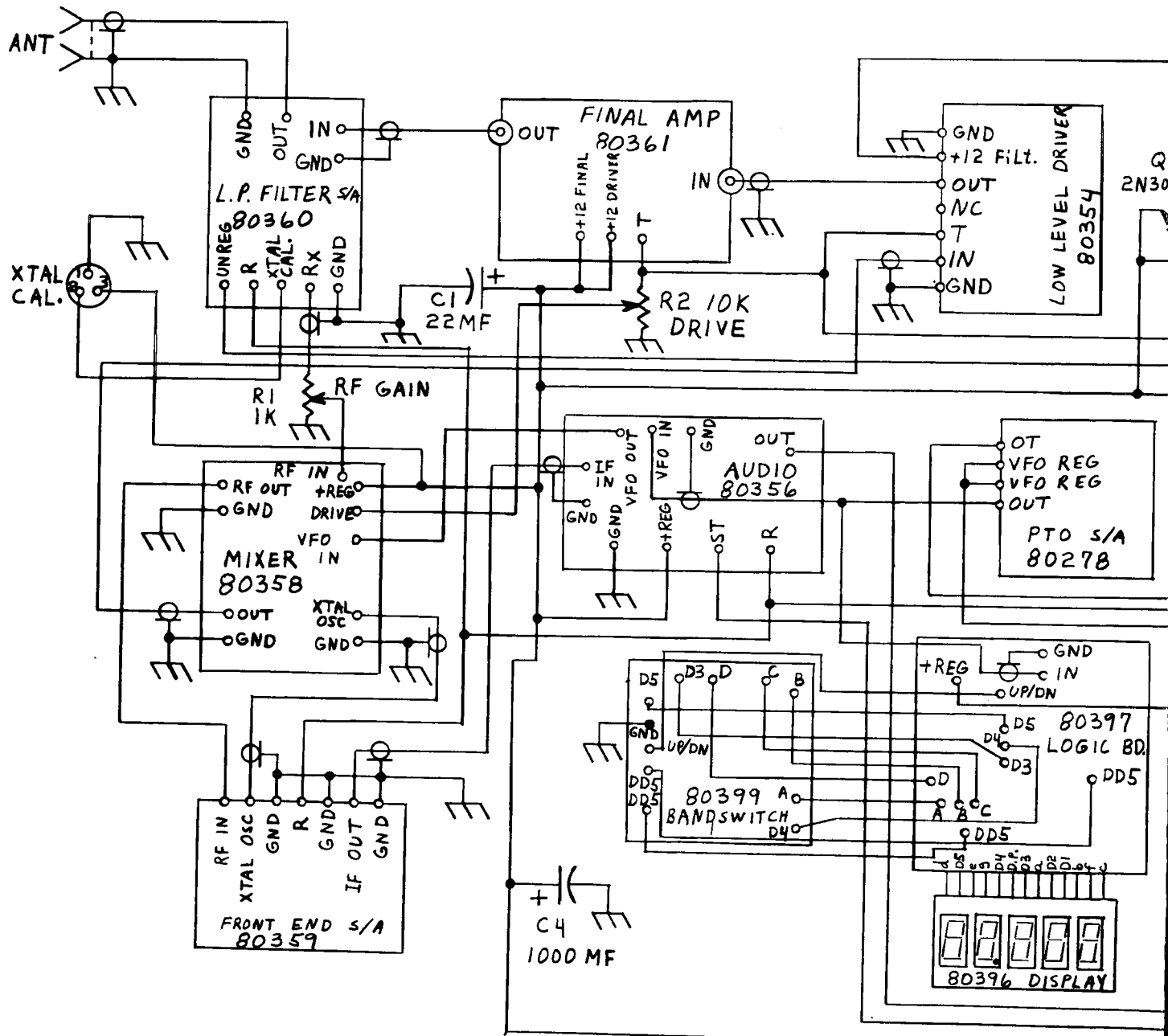

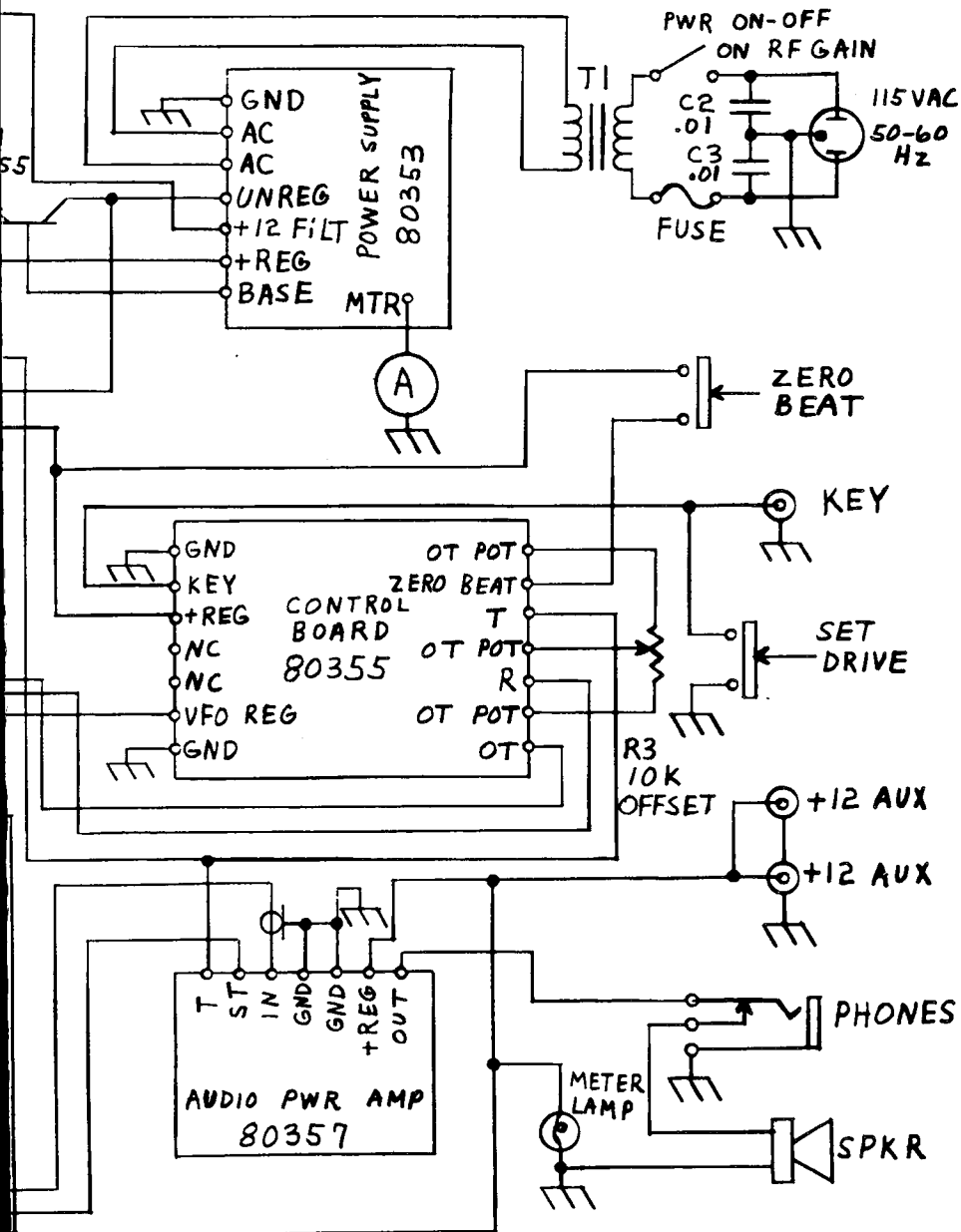

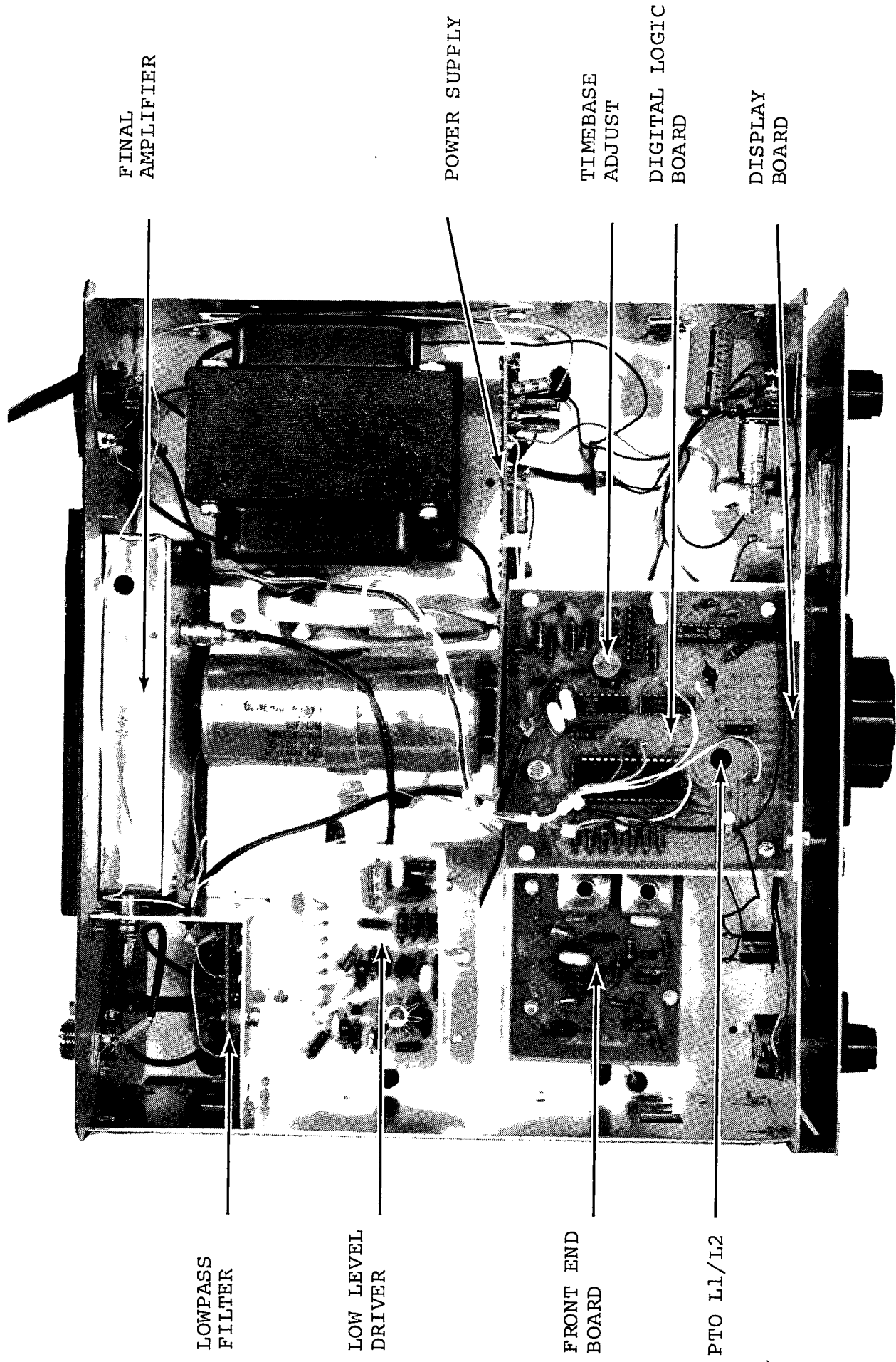

FIGURE 1 - TOP VIEW

BANDSWITCH ASSEMBLY

FUSE

CONTROL BOARD

AUDIO POWER AMP

AUDIO PRE-AMP  
SIDETONE LEVEL

MODEL 273  
CRYSTAL SOCKET

MIXER BOARD

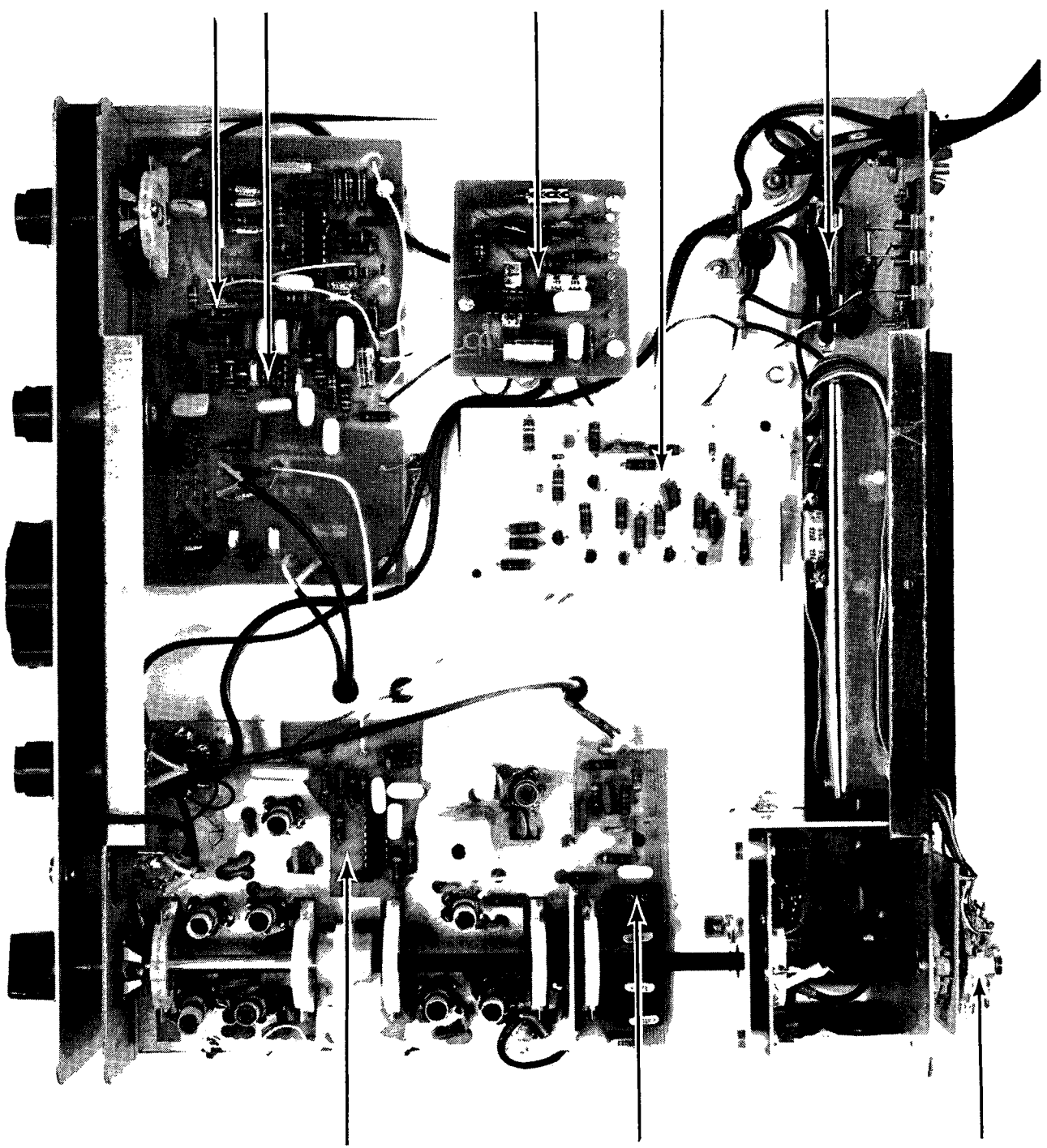

FIGURE 2 - BOTTOM VIEW

## 80359 FRONT END

This plug-in assembly contains the receiver mixer and i-f amplifier. The mixer is a double balanced diode bridge which receives input signal from the input bandpass filters through T1 and mixes it with the heterodyne crystal oscillator output to produce the 5.0 to 5.5 MHz i-f. Q2 is an i-f amplifier which feeds bandpass filter L1 and L2. Q1, a buffer amplifier, isolates the receiver mixer from the crystal oscillator.

The two coils making up the 5.0 to 5.5 MHz i-f filter are aligned at the factory and should not require field adjustment. They form an over coupled tuned circuit with broad response.

Pin Voltage Readings - (No signal conditions, DRIVE fully CCW)

Pin	Transmit	Receive
INPUT	0	0
XTAL OSC.	9.3	9.3
GND	0	0
R	.2	+11.7
GND	0	0
OUT	0	0
GND	0	0

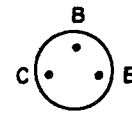

Transistor pins viewed from top of PC board.

Semiconductor Voltage Readings - (Receive)

Transistor	Collector	Base	Emitter
Q1	10.9	2.0	1.3
Q2	9.3	4.7	4.0

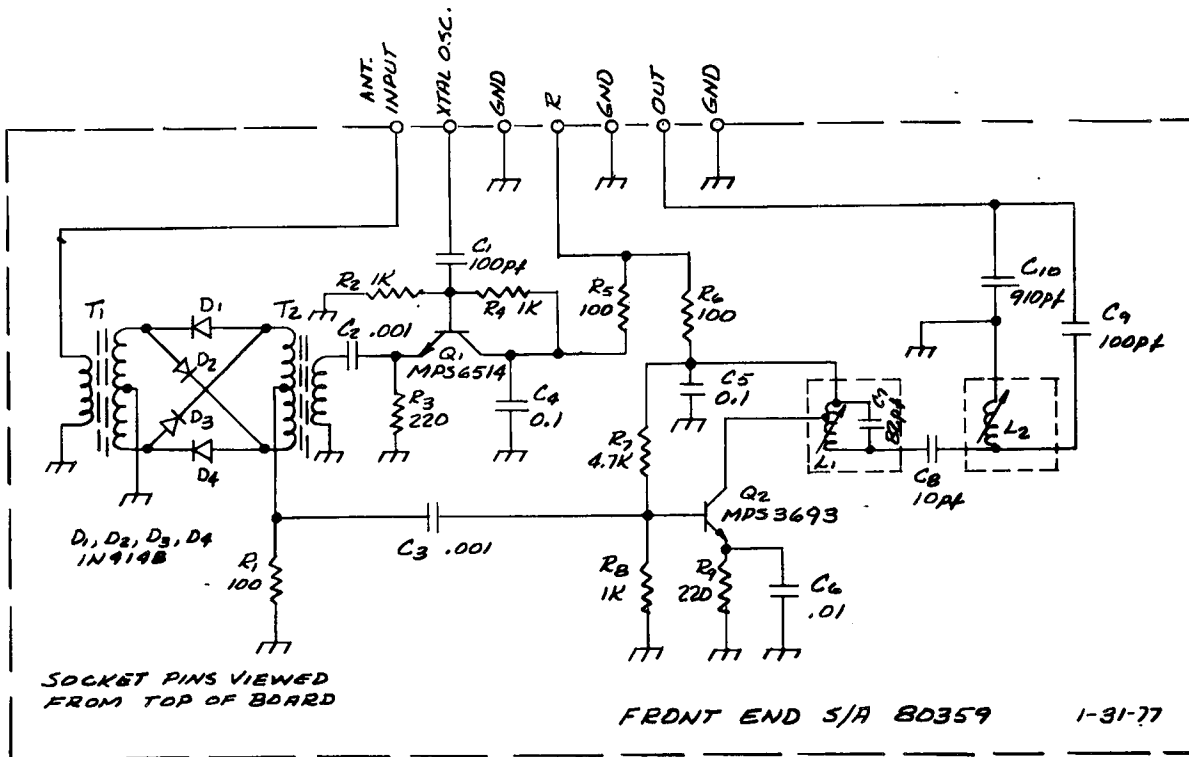
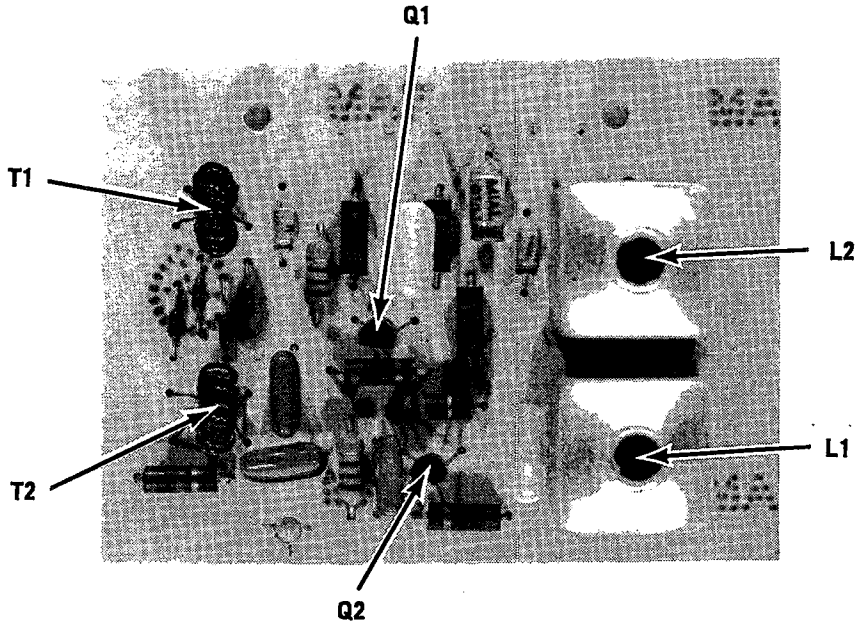

## 80356 AUDIO PRE-AMP

This board contains the receiver product detector, audio preamplifier, cw filter and sidetone oscillator. The product detector is similar to the receiver mixer except that the signals being mixed are the i-f from the Front End board and the VFO. The recovered audio is applied to a low noise two stage preamplifier, IC-2, which provides 60 dB gain. Response is tailored to provide a 2.5 kHz bandwidth. The preamp output is applied to AF GAIN control, R32. The cw filter consists of three sections of IC-1, the LM3900 quad operational amplifier. The cw filter is 3 sections of active filter, centered on 750 Hz. In the 1.0 kHz position, only one section is used. The .5 kHz position uses all three. The fourth section of IC-1 is used for the sidetone oscillator. Sidetone volume is controlled by thumbwheel potentiometer, R6, which is accessible through a hole in the bottom cover.

Semiconductor Voltage Readings - (Receive, DRIVE fully CCW)

<u>Pin</u>	<u>IC-2</u>	<u>IC-1</u>
1	1.3	0.6
2	1.3	0.6
3	0	0.6
4	7.4	5.5
5	7.5	5.5
6	11.5	0.6
7	1.3	0
8		0
9		5.3
10		0.1
11		0.6
12		0.5
13		0.6
14		11.5

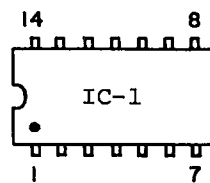
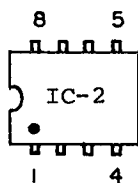

IC pins viewed from  
top of PC board.

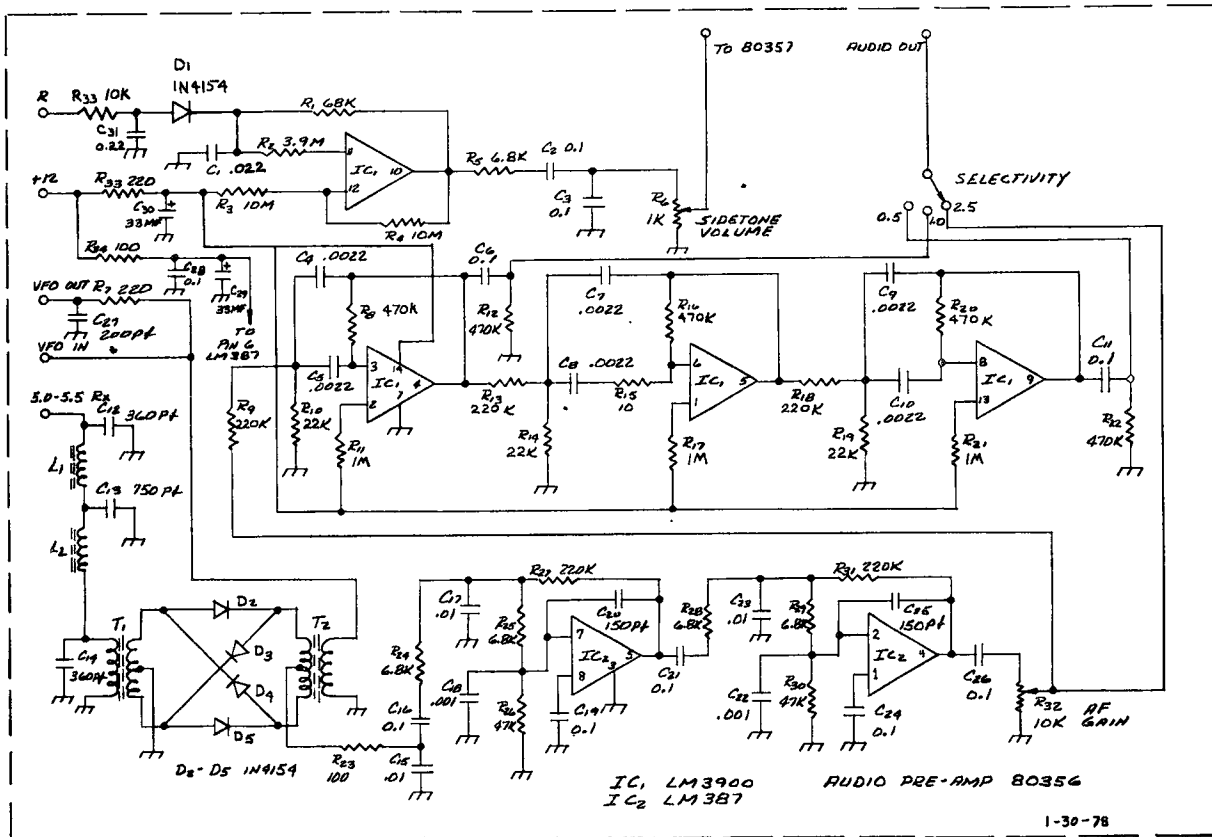
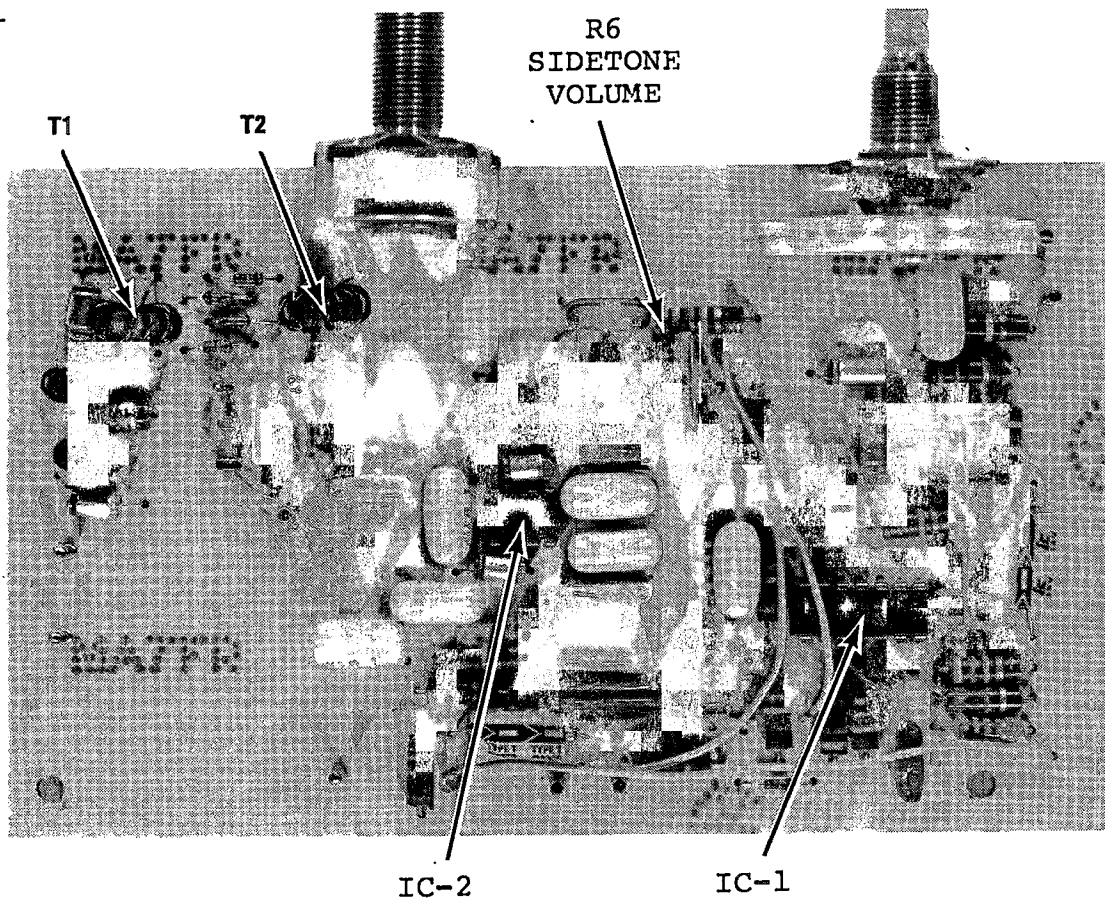

AUDIO PRE-AMP 80356

## 80357 AUDIO POWER AMP

Integrated circuit IC-1 contains the complete audio power amplifier. Input is applied at pin 2 and output taken from pin 8. The input signal is taken from either the received signal at the INPUT terminal, which passes through muting switch Q1, or from the SIDETONE terminal.

The input signal is shorted to ground whenever muting switch transistor Q1 is turned on. This occurs in the transmit mode by the application of the "T" voltage to its base circuit through D1. D1, C1, R1 and R2 form a delay circuit to slightly delay the turn-on time of the audio signal after transmitting.

Pin Voltage Readings - (No signal conditions, DRIVE fully CCW)

Pin	Transmit	Receive
T	10.2	0
SIDETONE	0	0
INPUT	0	0
GND	0	0
GND	0	0
+12v	12.8	12.8
OUT	0	0

Semiconductor Voltage Readings

Transistor	Collector		Base		Emitter	
	Transmit	Receive	Transmit	Receive	Transmit	Receive
Q1	0	0	0.6	0	0	0

IC-1

Pin	Pin
1	6.5
2	0
3	0
4	0
5	0
6	0
7	0
8	6.2
9	6.2
10	0
11	0
12	0
13	0
14	12.6

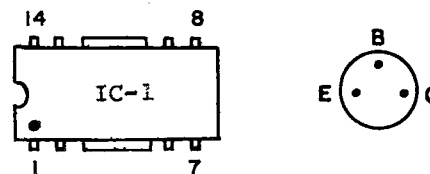

Semiconductor pins viewed from top of PC board.

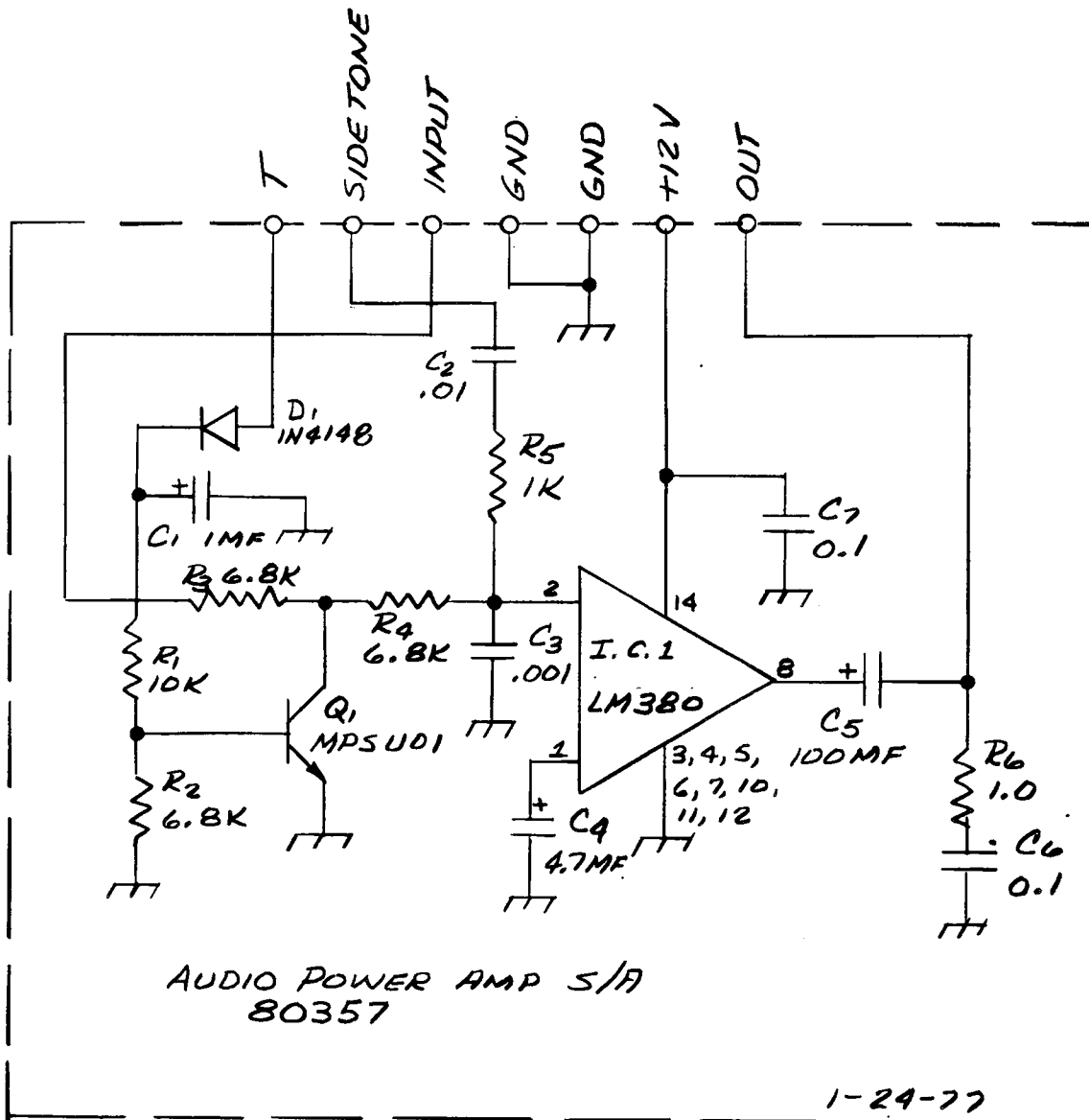
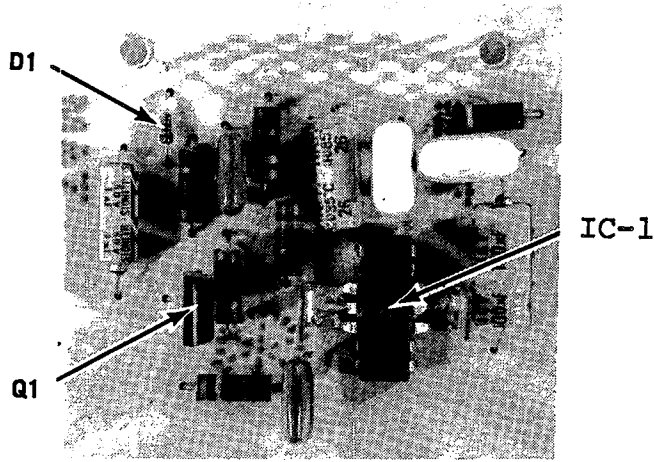

## 80278 PTO

The permeability tuned oscillator (PTO) provides the VFO for receive and the injection signal on transmit. It is housed in a sealed enclosure on top of the main chassis and below the digital readout mounting bracket. The main coil, L3, is shunted with L2 and has L1 in series. Adjustment of these two slug tuned coils, which are on the same coil form, determines the linearity and band edge points. The slugs can be accessed through the large hole in the 80397 LOGIC BOARD, mounted above the PTO assembly. L2 is the top slug, L1 is the bottom slug.

## SETTING PTO BAND EDGES

Coils L1 and L2 in the PTO assembly are adjusted at the factory for a total frequency excursion of about 580 kHz. The excess 80 kHz is about equally split so that the full CCW frequency is about 40 kHz below the bottom band edge, i.e. 3460, 6760, 13960 kHz, etc. The remaining 40 kHz extends to about 4040, 7540, 14540 kHz, etc. The overrun can be made to favor either the low or high band edge by merely touching up the top slug in L2. Hence out-of-band operation on MARS may be covered with the PTO up to about 80 kHz. If this is done, it must be remembered that the unequal overruns will be present on all bands. Also, since the readjusted band edge may be at or beyond the edge of the passband of the filters, the transmitter output power may be lower.



## DIGITAL READOUT

The frequency counter and digital display section of the Century/21 Model 574 consists of three separate printed circuit assemblies. The 80397 LOGIC BOARD contains the large scale integrated circuit, the display interfacing and driving circuits, signal pre-amp and Schmitt trigger, a ten-to-one prescaler, crystal controlled oscillator and dividers, dual pulse generator, and a voltage regulator to provide +5 volts. The five digit DISPLAY, 80396, consists of five individual 7-segment common cathode LED readouts, mounted on a printed circuit board, which is soldered to the 80397 LOGIC BOARD. The third assembly consists of a switched diode matrix which selects the correct preset codes for the three most significant digits. This assembly also contains switching circuits to select the up or down counting mode, and the first digit zero blanking signal which is used on 80 and 40 meters.

Since these circuits are very complex and contain MOS and CMOS integrated circuits that are susceptible to damage from static burnout if improperly handled, the following information will be limited to a general description of circuit operation.

It is suggested that a complete defective assembly be replaced instead of individual components. Full schematics and individual photos are included for those with adequate digital knowledge and test equipment. Many of the circuits contain pulsed signals so that straight dc measurements cannot be made. Instead, dc oscilloscope analysis is the only way to properly troubleshoot these circuits. Since it is not within the scope of these instructions to present detailed waveform analysis, general guidelines for troubleshooting are given, along with dc voltage measurements where they are valid.

THEORY OF OPERATION

The counter incorporates the latest in large scale integration. The MOSTEK MK50398N, IC-1, contains all of the counting, latching, multiplexing and output decoding functions on a single chip. This IC is mounted in a 28 pin socket on the 80397 assembly.

Input signal for the counter comes from the output pin of the 80278 PTO subassembly, and is typically 2 volts pk-pk and in the range of 5.0 to 5.5 MHz. This input signal is first passed through source follower Q1, and then to the Schmitt trigger circuit composed of Q2, Q3 and associated components. The Schmitt trigger converts the sine wave input into an approximate square wave output signal typically 4 volts pk-pk and at the same frequency as the input signal. This squared-up-signal is then fed to pin 14 of the divide-by-ten prescaler, IC-2, which divides the input signal by ten and also acts as a signal gate turned on and off by the 5 Hz signal applied to IC-2, pin 2. The divided output signal in the frequency range of 500 - 550 kHz is fed to pin 25, of IC-1, the large scale integrated circuit counter.

The time base generator is IC-4, which contains a crystal controlled oscillator and a 21 stage frequency divider. The crystal operating frequency of 5.242880 MHz is trimmed by C14 to calibrate the time base. This oscillator frequency is internally divided by a factor of  $2^{20}$  resulting in an output of 5 square waves per second. This timing signal is fed to IC-2, pin 2, where it functions as a gating signal to turn the prescaler on and off so that the input signal is counted for 100 milliseconds. During the remaining 100 milliseconds the counter preset information and the transfer of the counter information to the display circuits is carried out through two timing pulses, STROBE and LOAD, generated by IC-5, a dual monostable pulse generator. The input to IC-5 is the 5 Hz square wave generated by IC-4. The pulse widths are controlled by R13 and C15 (load pulse) and R14 and C16 (strobe pulse). The load pulse is positive and typically 5 ms long while the strobe pulse is negative and typically 50 us long. Both pulses have an approximate amplitude of 12 volts pk-pk.

The preset information needed to convert the readout indication from the actual counted frequency to the operating frequency is provided through the four program lines, pins 11 through 14 on IC-1. The programming diodes are located on 80399 BANDSWITCH assembly, mounted on the rear panel. On the 3.5 MHz and 14.0 MHz bands, 09.000 is preset by diodes D10 and D11. On the 7.0 MHz band,

12.500 is preset by diodes D1, D3, D4 and D7. On the 21.0 MHz band, 16.000 is preset by diodes D1, D5 and D6. On the 28.0 Mhz band, 23.000 is preset by diodes D2, D8 and D9. In the 28.5 position, 23.500 is preset by diodes D2, D3, D4, D8 and D9. The up/down counting mode is selected by switch SW-3A, mounted on the rear panel. On the 3.5 and 7.0 MHz bands, the "down" counting mode is selected. On all other bands, the "up" counting mode is selected. Information from SW-3A is connected to IC-1, pin 28 on the 80397 assembly. The left most digit is blanked on 3.5 MHz and 7.0 MHz bands by switch SW-2B which connects to terminals DD5. This is done to improve the readability when this digit is not required.

IC-6 on assembly 80397 is a three terminal voltage regulator which provides +5 volts to operate IC-2, the 7490 decade counter. All other circuits are fed from the +12 volt line through appropriate decoupling circuits.

The DISPLAY assembly, 80396, consists of five 0.3" high red LED, seven segment, common cathode readouts mounted on a PC board. The board is painted black prior to installation of the readouts. The segment drive signals come from IC-1 on assembly 80397, with current limiting provided by R1 through R7 for segments a through f. R12 limits the current in the decimal point segment. The digit drive signals from IC-1 are buffered by IC-3, a hex digit driver circuit, which then drives each digit in the display. The display information is multiplexed by IC-1 at a frequency determined by C8, typically between ten and twenty kHz.

#### SERVICING HINTS

Use the following procedures to locate the faulty assembly. If well versed in digital techniques, check waveform and signal paths as indicated.

- 1.) Check all dc voltages given. If any is more than 20% different from value indicated, look to this area of the circuit for faulty component.
- 2.) If all dc measurements are within normal range, determine probable malfunctioning area by analyzing trouble symptoms. If, for example, one digit is dark or always reads 8, the trouble is likely to be in IC-3, the digit driver. Or, if any particular segment is dark or lit all of the time on all five digits, the problem is probably in IC-1, or on the DISPLAY assembly.
- 3.) Use an oscilloscope to check these problems:
  - a.) If the readout shows only the preset codes and does not change when tuning the PTO, the problem may be a lack of signal transfer through Q1, Q2, Q3 or IC-2. Also, the reset line, pin 2 of IC-2, may be latched, thus preventing input pulses to IC-2 from reaching the input of IC-1.
  - b.) Verify operation of the crystal time base oscillator and divider by examining IC-4, pin 12. Also check IC-5, pins 7 and 10, for correct pulses.
- 4.) Incorrect preset information from the 80399 BANDSWITCH assembly is most likely due to defective switch wafers or diodes. Proper operation can be verified by removing the PTO input signal and observing the presets on each band. Compare the results observed with the correct values mentioned earlier.

SEMICONDUCTOR VOLTAGE READINGS ON 80397 LOGIC BOARD

<u>Q1</u>		<u>Q2</u>		<u>Q3</u>
Drain	13.2	Collector	6.31	2.76
Gate	0	Base	0.13	-1.06
Source	2.11	Emitter	0	0

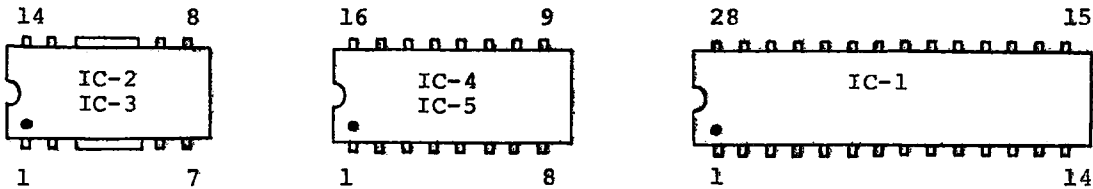
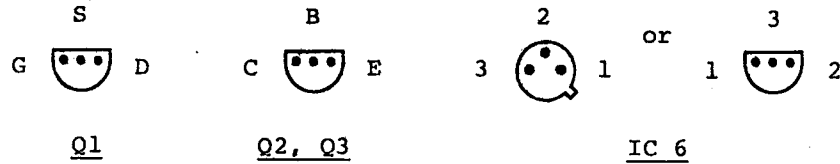

All semiconductor pins viewed from top of PC board.

PIN	IC-2	IC-3	IC-4	IC-5	IC-6
1	DNM	DNM	DNM	0	13.2
2	DNM	DNM	0	DNM	5.0
3	5.0	DNM	0	13.2	0
4	5.0	0	DNM	DNM	---
5	5.0	0	13.1	13.2	---
6	0	0	DNM	DNM	---
7	0	DNM	DNM	DNM	---
8	DNM	DNM	0	0	---
9	DNM	DNM	0	DNM	---
10	0	DNM	DNM	DNM	---
11	DNM	13.2	DNM	DNM	---
12	DNM	DNM	DNM	0	---
13	0	DNM	DNM	13.2	---
14	DNM	DNM	DNM	DNM	---
15	---	---	DNM	0	---
16	---	---	13.1	13.2	---

DNM = Do Not Measure. Pulses present.

IC-1

Pins 1, 2: 13.2 volts  
 Pin 28: Zero on 3.5 and 7.0 MHz bands. 13.2 on all other bands.  
 Pins 15, 17, 26: Zero  
 All other pins have pulses present and cannot be measured with a dc voltmeter.

WIRING CODE FOR DIGITAL READOUT  
WIRING HARNESS

COLOR	TERMINAL LABEL	FUNCTION
Brown	up/dn	Selects counting mode
Red	A	Preset code "1"
Orange	B	" " "2"
Yellow	C	" " "4"
Green	D	" " "8"
Blue	D3	" data from D3
Violet	D4	" " " D4
Gray	D5	" " " D5
White/Black (2 wires)	DD5	Leading digit blanking
<b>Additional wires:</b>		
Red	+12V	Supplies +12 volts to PC board
Coax	INPUT	Input signal from PTO

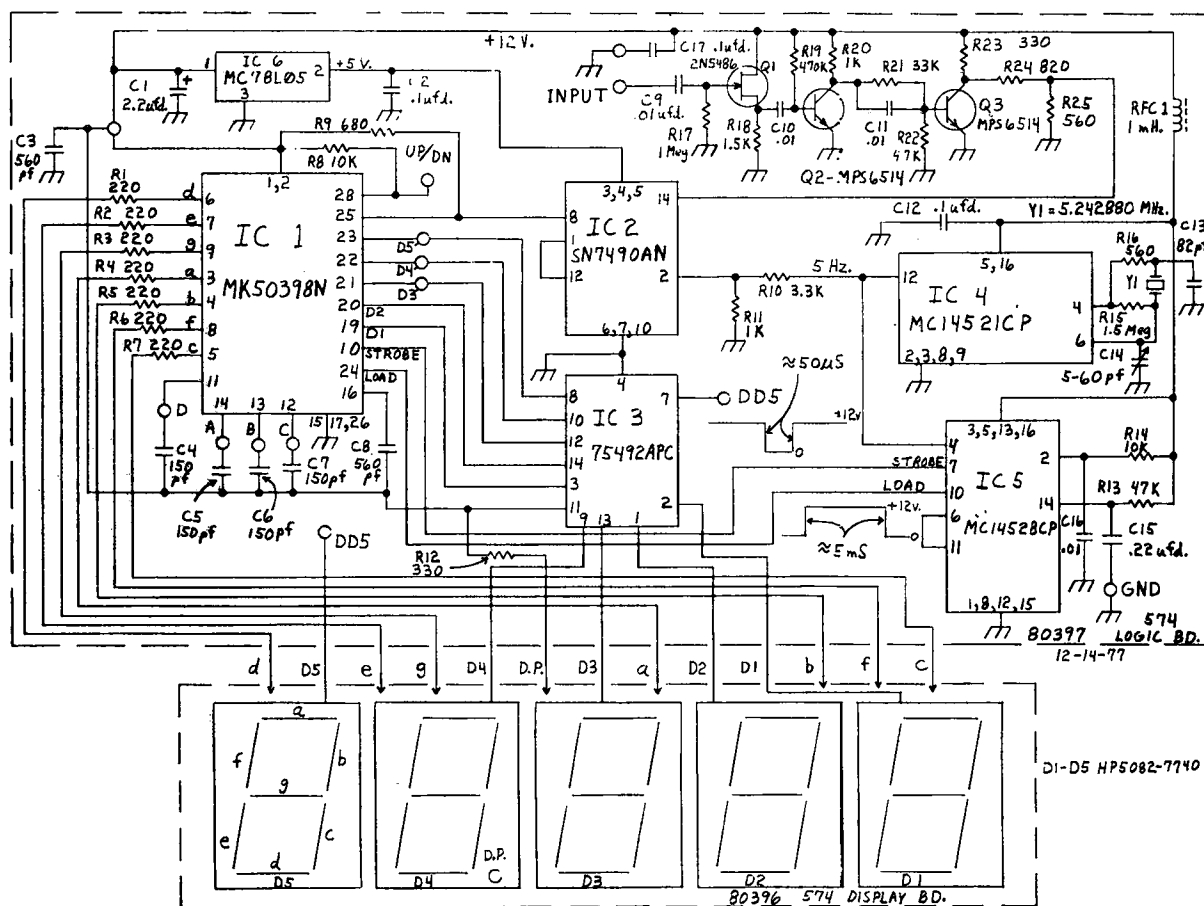
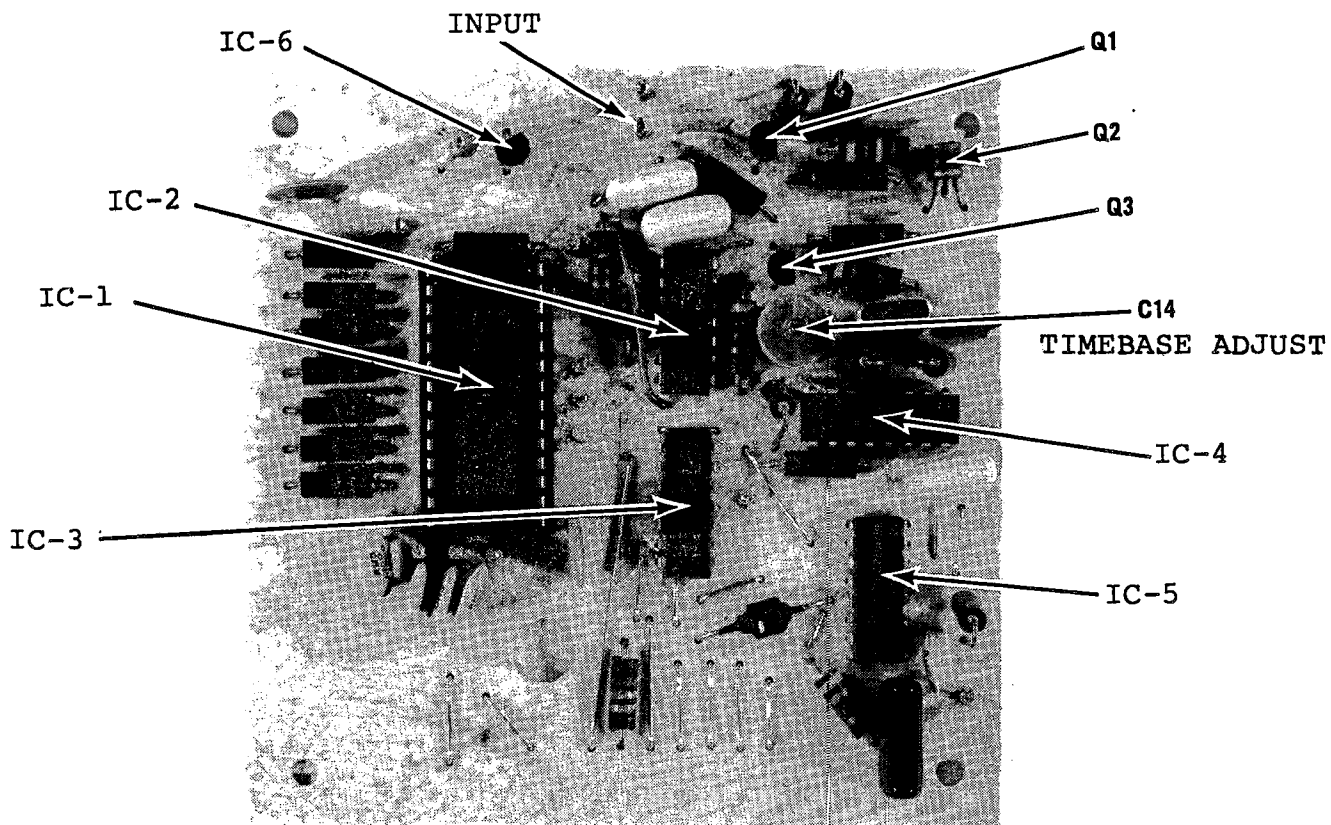

LOGIC BOARD 80397

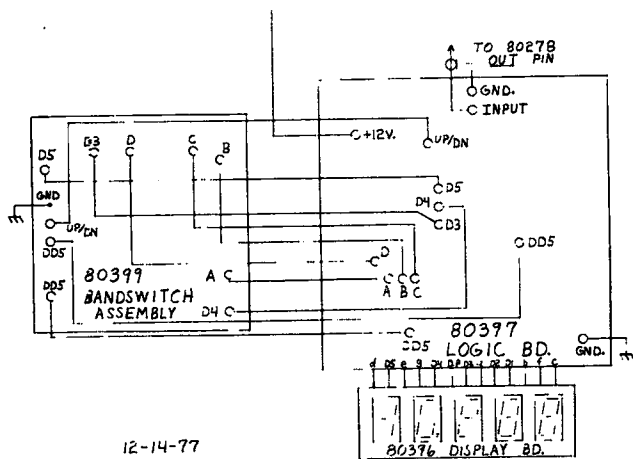
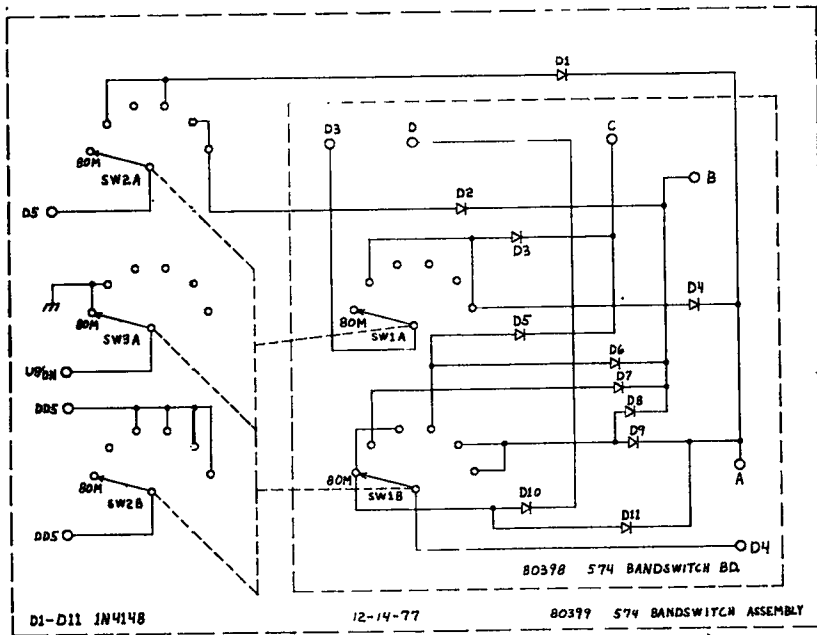
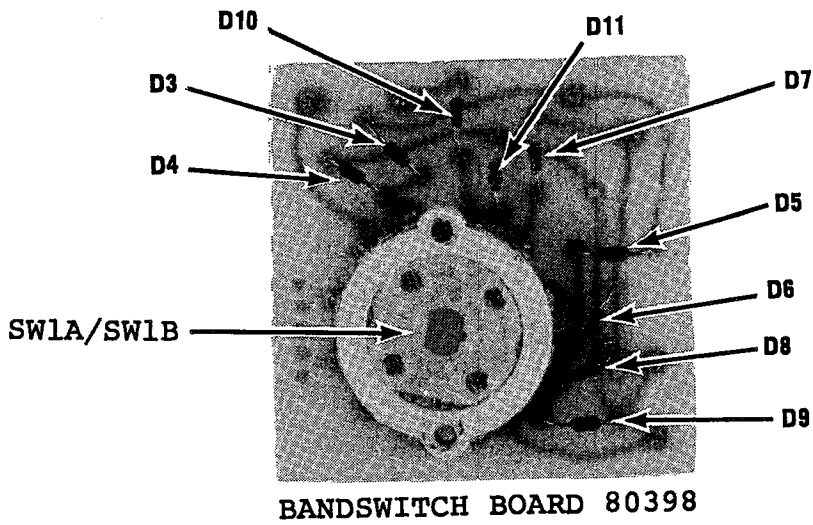

WIRING DIAGRAM

## 80358 MIXER

This assembly contains all of the switched bandpass circuits, the crystal heterodyne oscillator and the transmitter mixer. Transformers T1 through T5 are the transmit bandpass circuits and T6 through T10 are the receiver antenna coupling bandpass circuits. All are overcoupled tuned circuits and being fairly broad, require no field alignment.

IC-1 is an active double-balanced mixer which generates the transmitted signal by mixing the VFO signal with the crystal oscillator signal.

Q1, the crystal oscillator, feeds both receiver and transmitter mixers. Sockets for the accessory crystals are located along the back edge of the board.

Semiconductor Voltage Readings - (Receive, DRIVE CCW)

Transistor	Collector	Base	Emitter
Q1	12.2	9.5	9.7

IC-1

Pin	
1	6.2
2	5.8
3	5.8
4	6.2
5	0
6	12.4
7	12.4
8	9.0
9	0
10	9.0
11	0
12	11.9
13	0
14	0

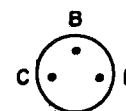
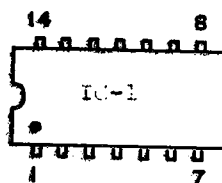

Semiconductor pins viewed  
from top of PC board.

CRYSTALS

ACCESSORY 273      FACTORY INSTALLED 272      271

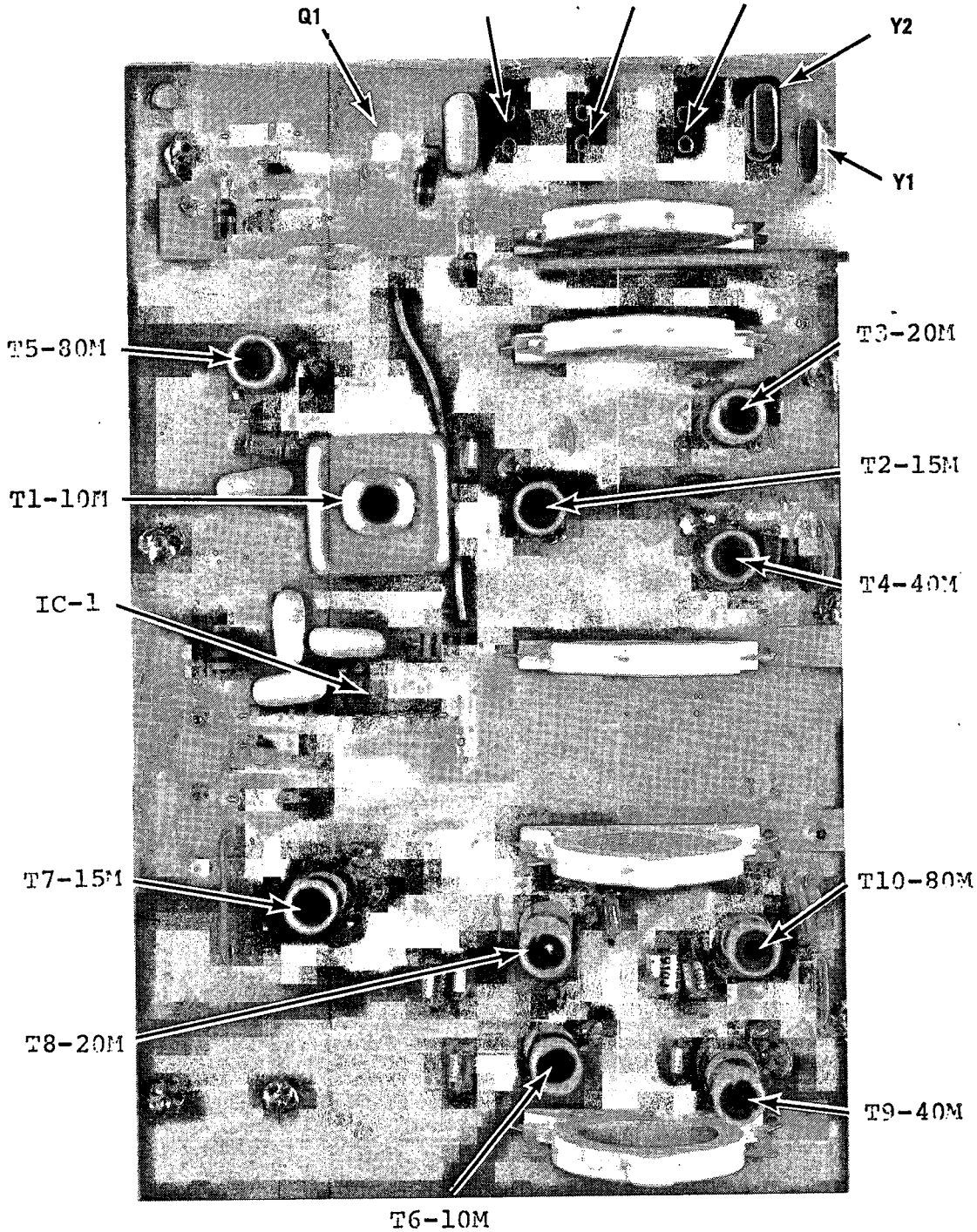

80358 MIXER

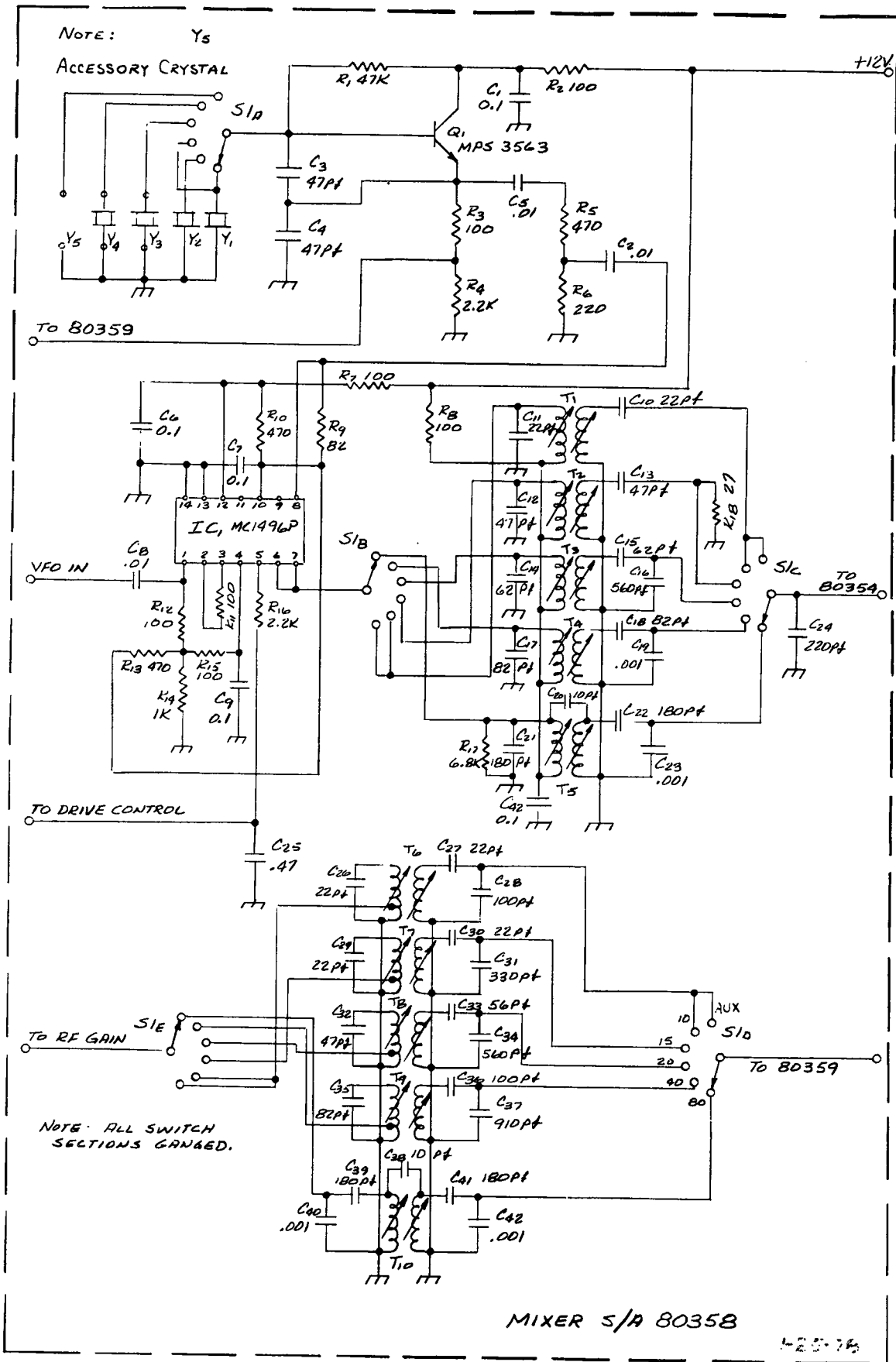

35-574 3-78

42575

## 80354 LOW LEVEL DRIVER

This assembly contains three Class A linear amplifier stages to increase the level of the signal from the transmit mixer to that required to drive the final amplifier. The second and third stages, Q2 and Q3, are biased from the "T" line by diodes D1 and D2. Since all three amplifiers are broad band designs, no tuning or adjustments are necessary.

Pin Voltage Readings - (DRIVE fully CCW)

Pin	Transmit	Receive
GND	0	0
IN	0	0
T	10.2	0
NC	-	-
OUT	0	0
+12	12.6	12.6
GND	0	0

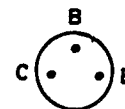

Transistor pins viewed from top of PC board.

Semiconductor Voltage Readings - (DRIVE fully CCW)

Transistor	Collector		Base		Emitter	
	Transmit	Receive	Transmit	Receive	Transmit	Receive
Q1	6.5	7.4	1.5	1.8	0.8	1.1
Q2	9.4	11.4	1.2	0	0.5	0
Q3	12.6	12.6	1.3	0	0.6	0

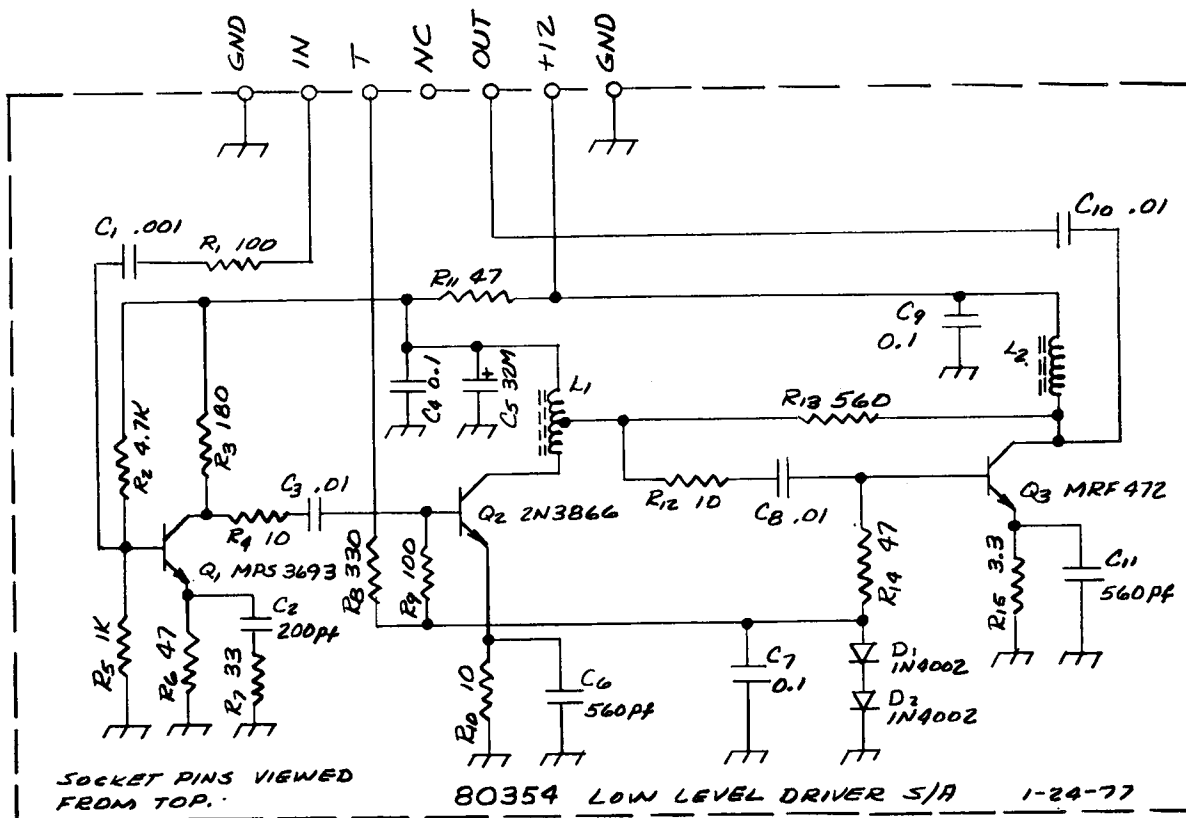
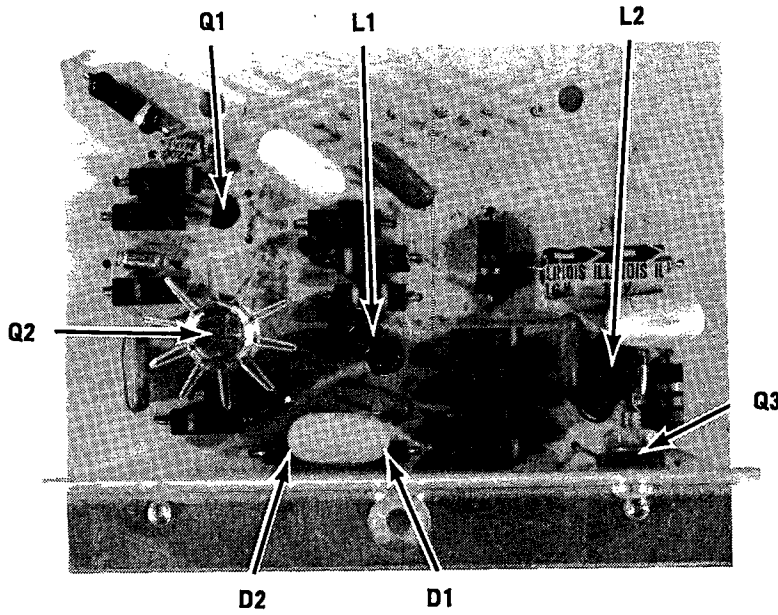

LOW LEVEL DRIVER 80354

## 80361 FINAL AMPLIFIER

The high power rf amplifier and its push-pull driver stage are housed in a metal box which is an integral part of the heat sink assembly. The unit is attached to the rear panel by four screws and connections are made by means of two phono connectors for rf input and output and three soldered-on leads for control and power.

Q1 and Q2 constitute a Class AB linear push-pull driver stage of wide band design. Impedance matching into and out of this stage is by means of transformers T1 and T2. Operating bias is applied whenever voltage is applied to the "T" terminal. Quiescent current in the collector circuit is adjusted to 6 mA by potentiometer R5.

Power amplifier transistors Q3 and Q4 are biased to Class C.

Bias for the driver stage is temperature compensated to maintain a relatively constant operating point by mounting the bias diode in direct contact with the heat sink.

Since all transistors are inaccessible inside the shield enclosure, no voltage measurements can be made at their terminals. However, voltages going to the feedthrough terminals can be checked to the following values:

Terminal	Wire Color	Transmit	Receive
Final +12	red	+12.5	+12.5
Driver +12	red	+12.5	+12.5
T	blue	+10.2	0.0

3-29

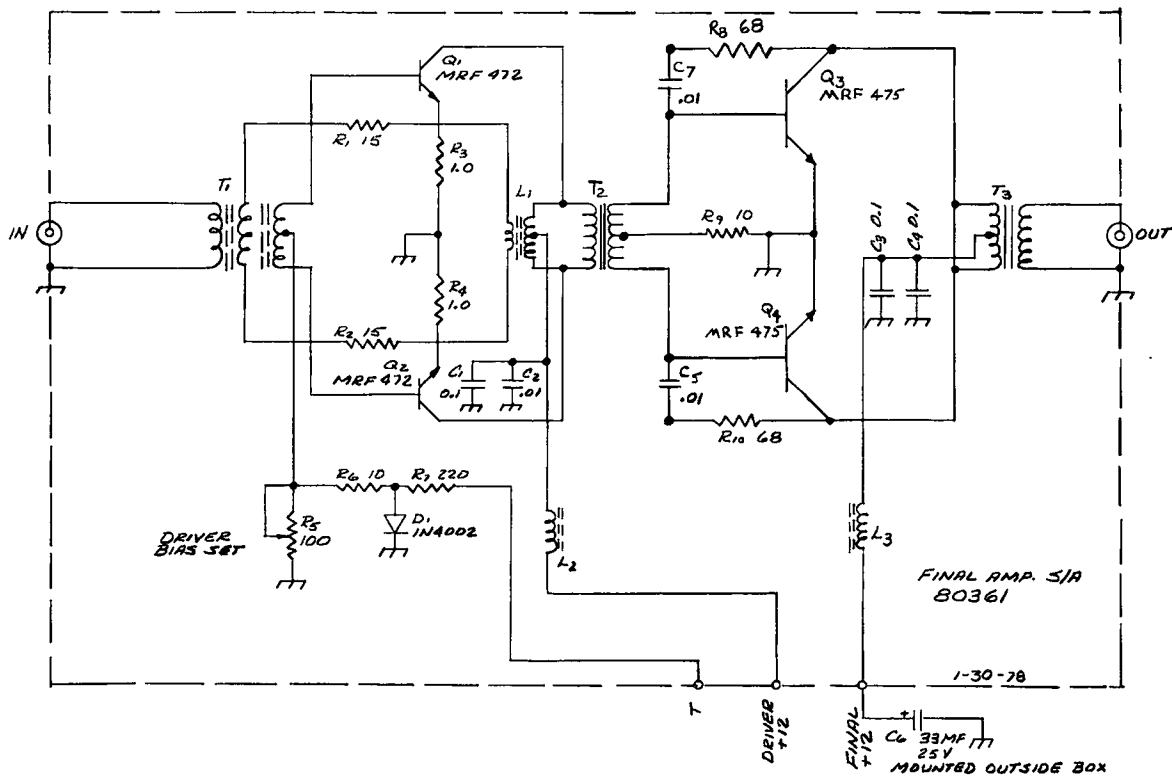
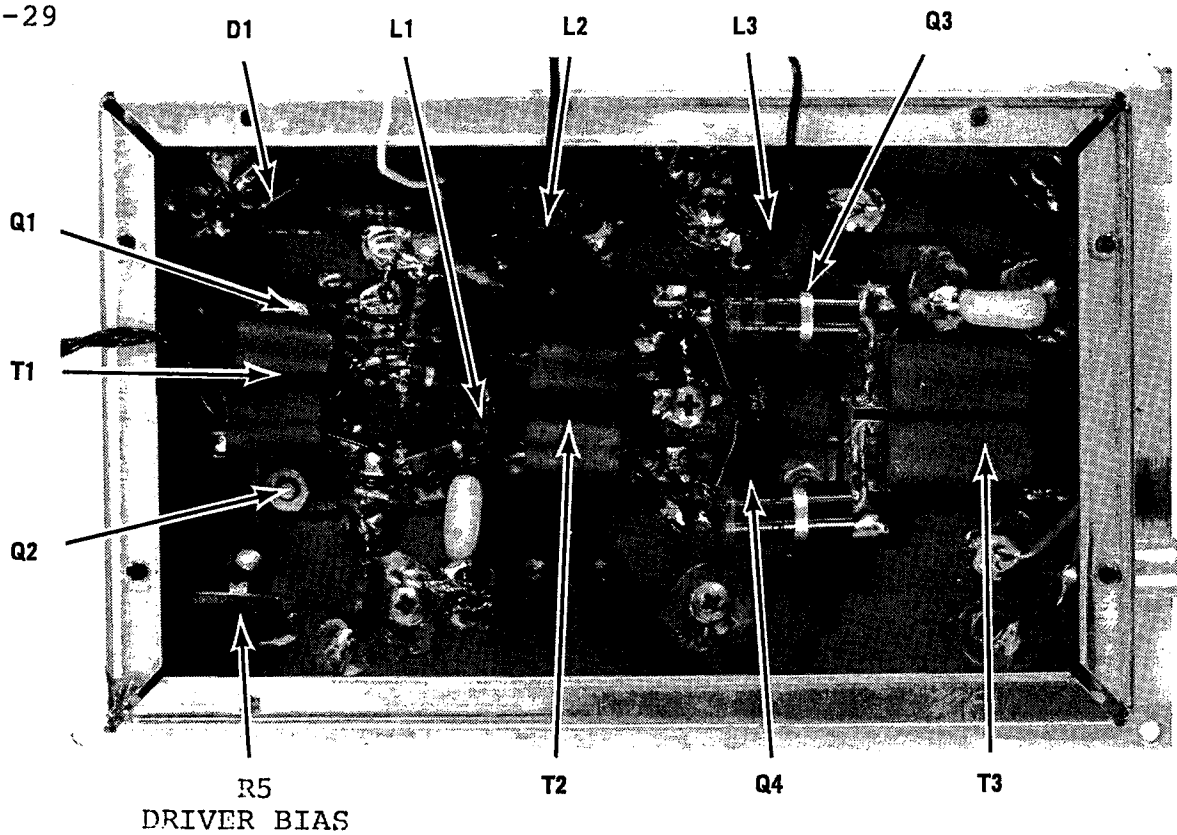

FINAL AMPLIFIER 80361

3-78

40-574

## 80360 LOW PASS FILTER

The output signal from the final rf amplifier contains harmonic components above desirable levels. The push-pull configuration decreases the even order components to some degree, but does not cancel out the odd harmonics. To further decrease evens and odds, the output signal is passed through a set of five pole low pass filters before being radiated. The proper filter is selected by the BAND switch.

This assembly also contains the T/R antenna switch. This circuit disconnects the receiver input from the antenna whenever the key line is shorted. The circuit consists of a PIN diode and transistor switch. In the receive mode the PIN diode is forward biased providing a low loss path between the antenna and the receiver. In transmit the transistor is biased off and the diode is reverse biased by approximately 23 volts from the power supply, which essentially disconnects the receiver from the antenna.

Semiconductor Voltage Readings - (DRIVE fully CCW)

Transistor	Collector		Base		Emitter	
	Transmit	Receive	Transmit	Receive	Transmit	Receive
Q1	23	0.2	0	0.7	0	0

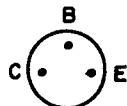

Transistor pins viewed from  
top of PC board.

Slf Slg

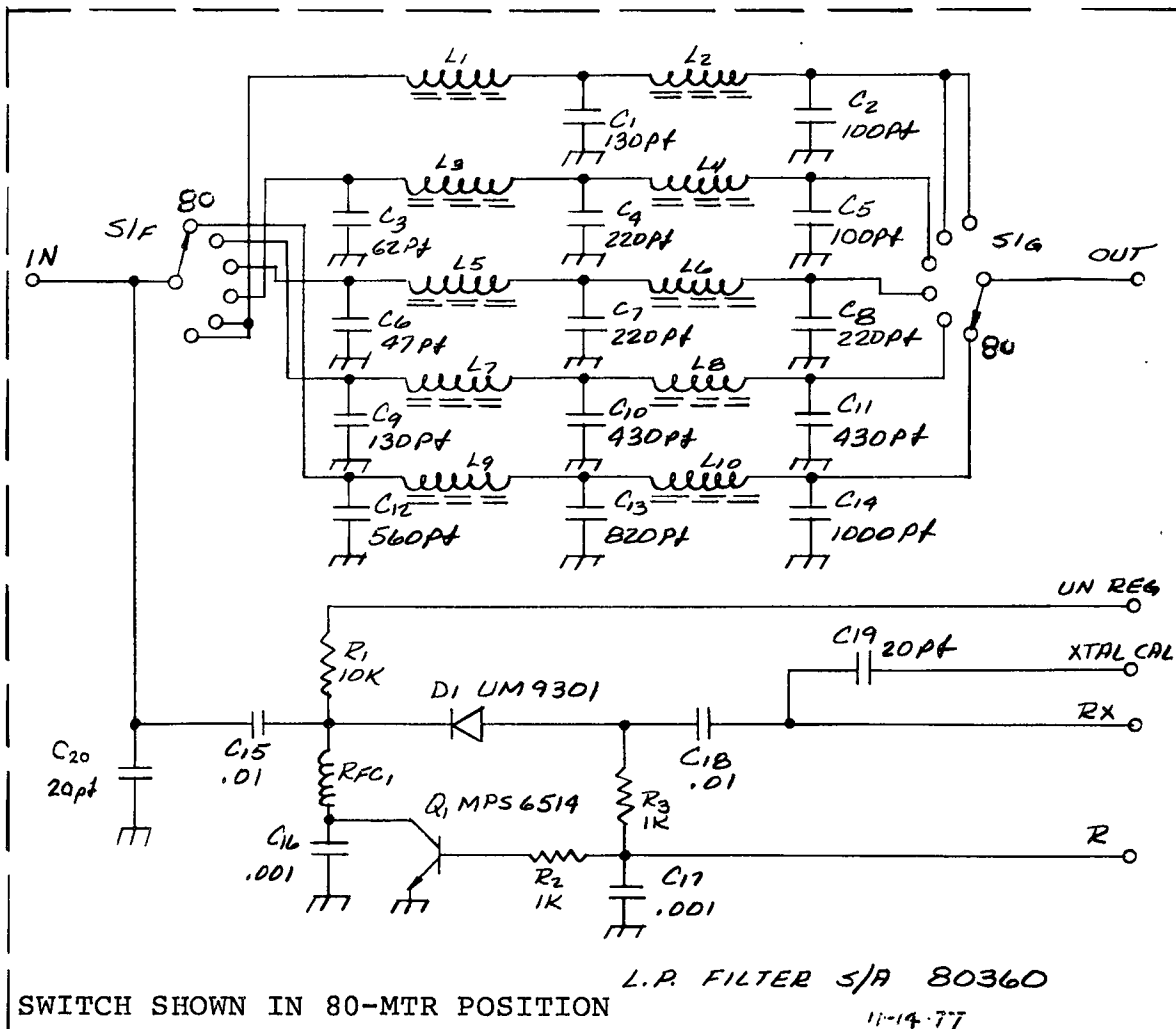
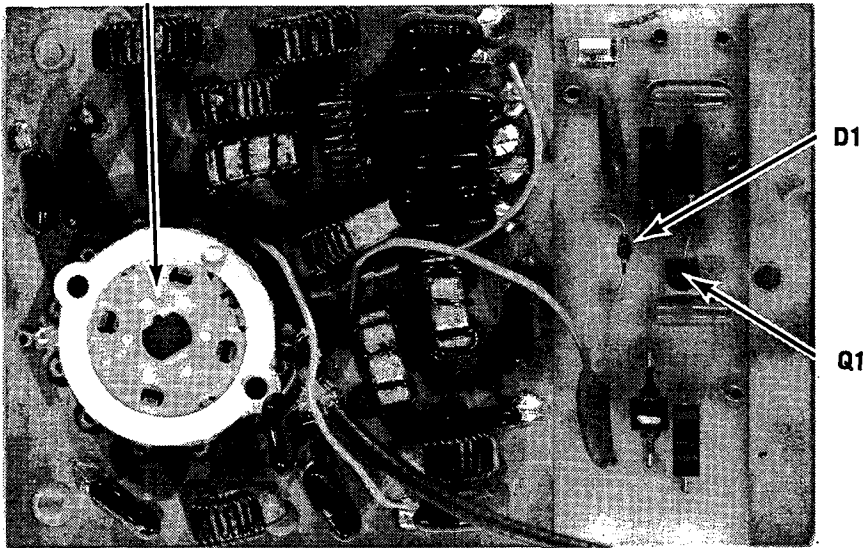

LOW PASS FILTER 80360

## 80355 CONTROL BOARD

This assembly contains a set of synchronous transistor switches which control the "T" and "R" voltages that switch the CENTURY from receive to transmit. It also provides a regulated voltage which powers the PTO and offset tuning circuitry.

Transistors Q1, Q2, and Q3 constitute the "T" voltage switch which produces operating voltage on the "T" terminal whenever the KEY line is closed. The presence of "T" voltage at the base of Q4 switches off the normally present "R" voltage through switches Q5 and Q6.

The OFFSET control voltage for the varactor diode in the PTO is derived through steering diode D3 through terminal OT. The amount of control voltage varies between 3 and 6 volts as determined by the setting of the OFFSET control and resistors R13 and R18. When transmitting or with the ZERO BEAT switch pushed, Q8 is turned on, back biasing D3 and thereby disconnecting the voltage divider from the OT terminal. At the same time, Q7, which was previously turned on and back biasing D2, goes to an off state and inserts the voltage from the divider formed by resistors R10, R11 and R12, through the forward biased D2 to the OT terminal. Trimpot R12 is adjusted to a value equal to the center position voltage of the OFFSET control, in essence the voltage representing no offset.

To adjust R12, turn the OFFSET control to its center zero position. Tune in a station with the main tuning knob and adjust to zero beat. Then push the ZERO BEAT button and adjust R12 for the same pitch. Check by retuning to a slightly different pitch and pushing the ZERO BEAT knob. The pitch should stay the same.

Pin Voltage Readings - (DRIVE fully CCW, OFFSET knob centered)

Pin	Transmit	Receive	Pin	Transmit	Receive
GND	0	0	OT POT	0	2.5
KEY	0	4.5	OT ON/OFF	.7	0
+12	12.5	12.5	T	10.1	0
NC	-	-	OT POT	0	4.3
NC	-	-	R	0	10.9
+9	8.9	8.9	OT POT	3	5.8
GND	0	0	OT	3.8	3.8

Semiconductor Voltage Readings

Transistor	Collector		Base		Emitter	
	Transmit	Receive	Transmit	Receive	Transmit	Receive
Q1	11.9	.1	0	.7	0	0
Q2	12.6	12.6	11.9	.13	11.2	0
Q3	0	0	10.7	.1	10.0	0
Q4	.1	12.1	.7	0	0	0
Q5	12.6	12.6	.1	12.1	0	11.4
Q6	0	0	.1	12.1	.1	10.9
Q7	4.3	0	0	.6	0	0
Q8	0	4.3	.7	0	0	0

Transistor pins viewed  
from top of PC board

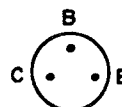

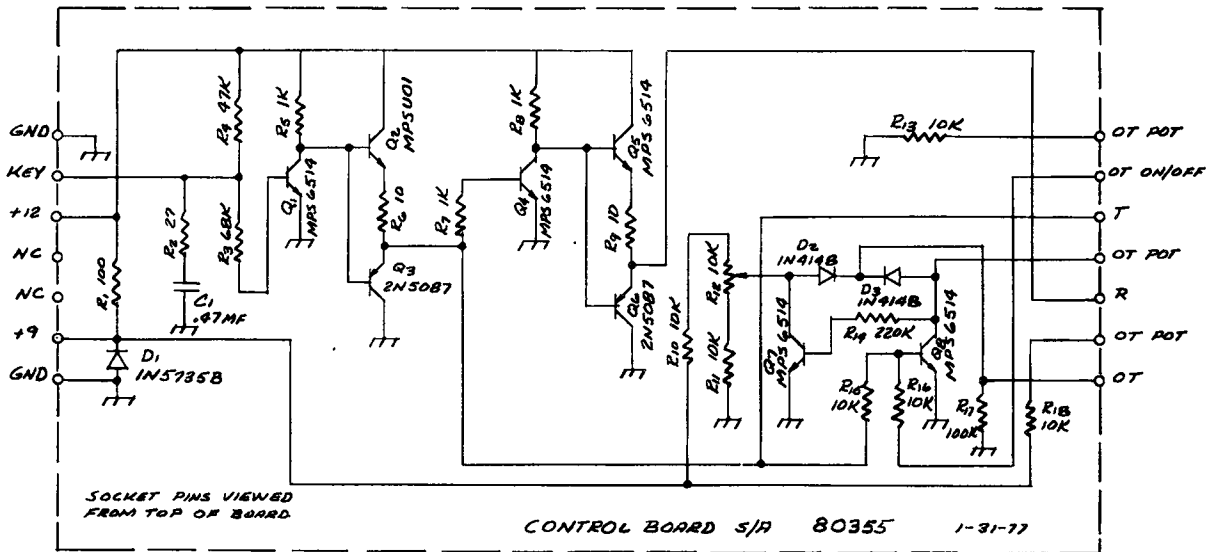
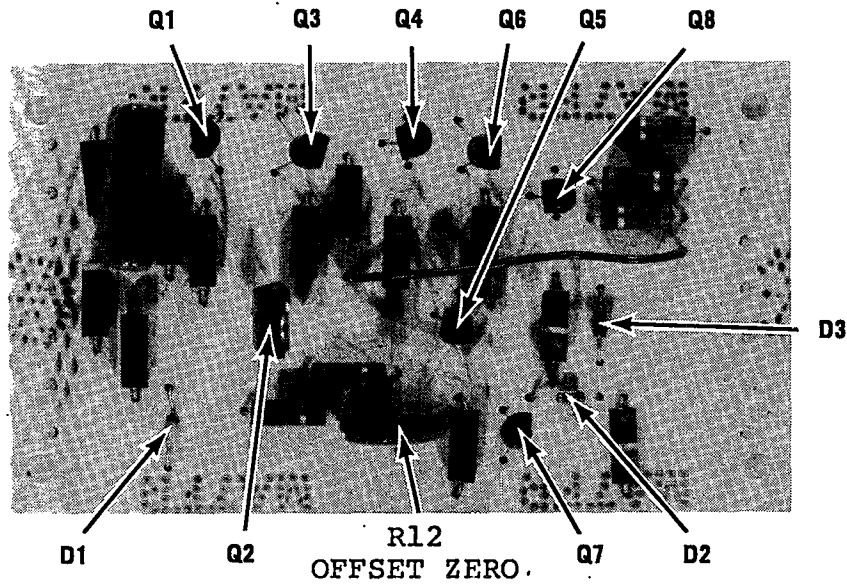

CONTROL BOARD 80355

80353 POWER SUPPLY

This assembly contains a bridge rectifier, filter capacitor, regulator, shut-down circuits and the meter shunt. The output voltage is fixed at 12.8v and the current trip is set to 6A at the factory. Voltage regulation is provided by IC-1 which drives the darlington series pass element consisting of Q1 and the 2N3055 mounted on the rear panel. When current drawn from the supply exceeds the trip value as determined by the setting of R1, sufficient gate drive is applied to SCR Q2 to turn it on. This shorts the output of IC-1 and removes base drive from the series pass element. Under this condition, IC-1 is protected by the voltage drop across R5 which activates the current limiting circuits inside the integrated circuit. The front panel meter is calibrated by means of thumbwheel potentiometer R7.

Calibration of the meter and trip point requires an adjustable 2.5 ohm 100 watt load resistor and a 10 ampere dc meter. The load resistor and ammeter are connected in series and bridged across one of the Aux 12 VDC output jacks on the rear panel. Calibrate meter in receive mode and not transmit. The load resistor is adjusted for a current of 6 amperes as indicated on the ammeter and R7 is set for a meter reading of 70 watts. Then R1 is adjusted so the power supply trips at the same 70 watt point.

Semiconductor Voltage Readings - (Receive mode)

Transistor	Collector	Base	Emitter
Q1	23.0	13.8	13.2
	Anode	Cathode	Gate
Q2	13.8	-.06	-.03

IC-1	Normal	Tripped
1	0	0
2	13.8	8.0
3	13.8	.8
4	0	0
5	7.0	6.3
6	7.0	6.3
7	0	0
8	0	0
9	7.6	1.6
10	13.8	5.5
11	23	15.6
12	23	15.6
13	14.9	6.7
14	0	0

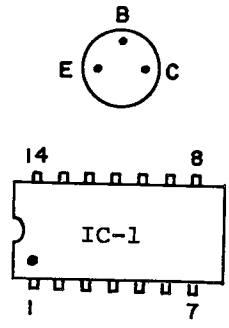

Semiconductor pins viewed from top of PC board.

R6 METER CALIBRATE  
R1 CURRENT LIMIT ADJ.

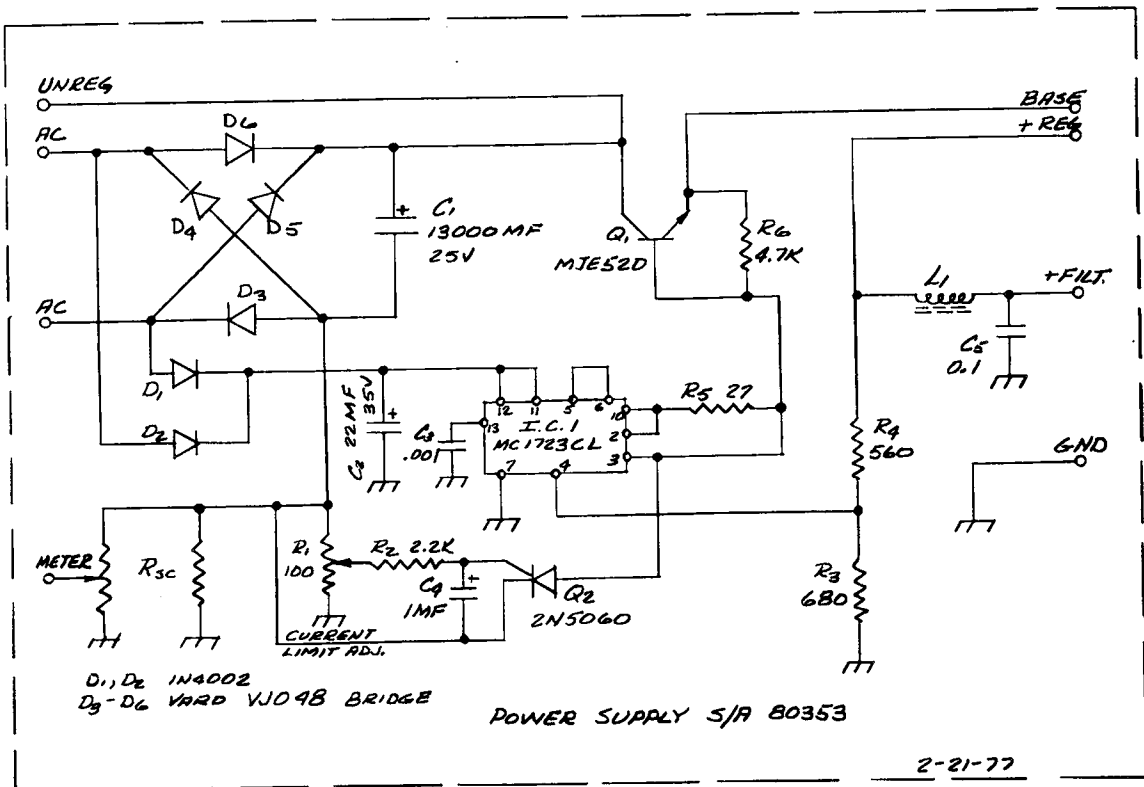
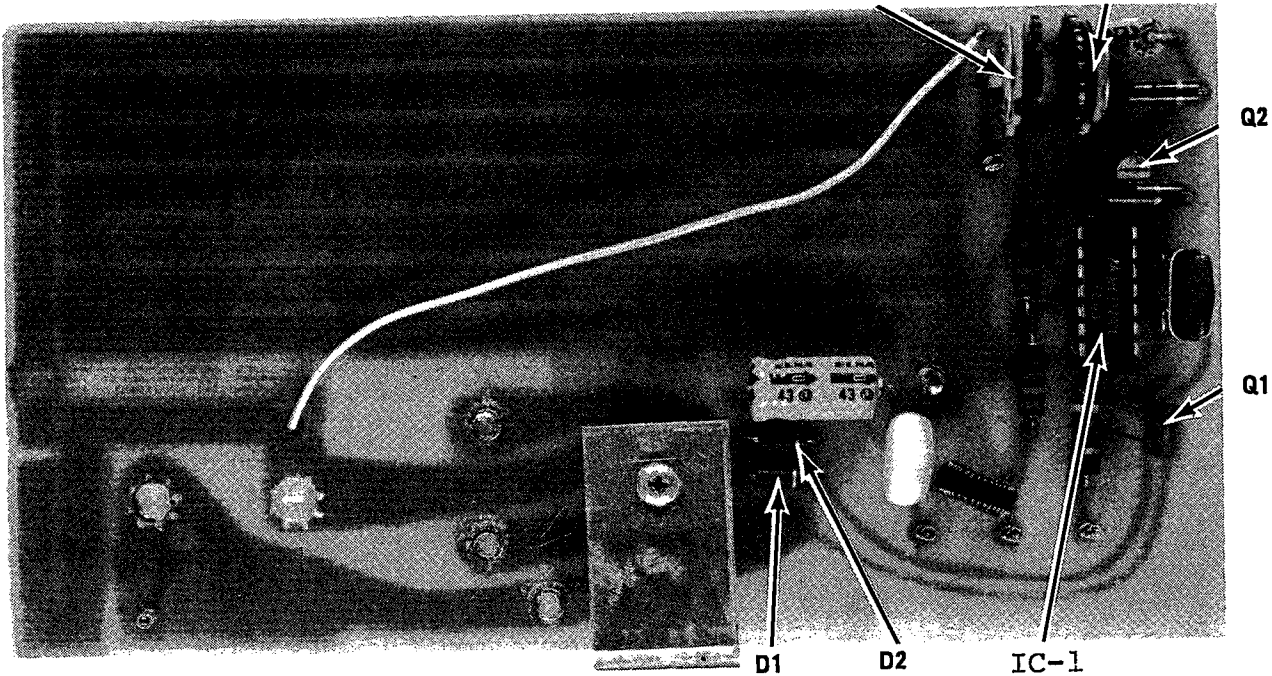

POWER SUPPLY 80353