

TEN-TEC

**OPERATOR'S
MANUAL**

**DELTA
580**

580 DELTA TRANSCEIVER

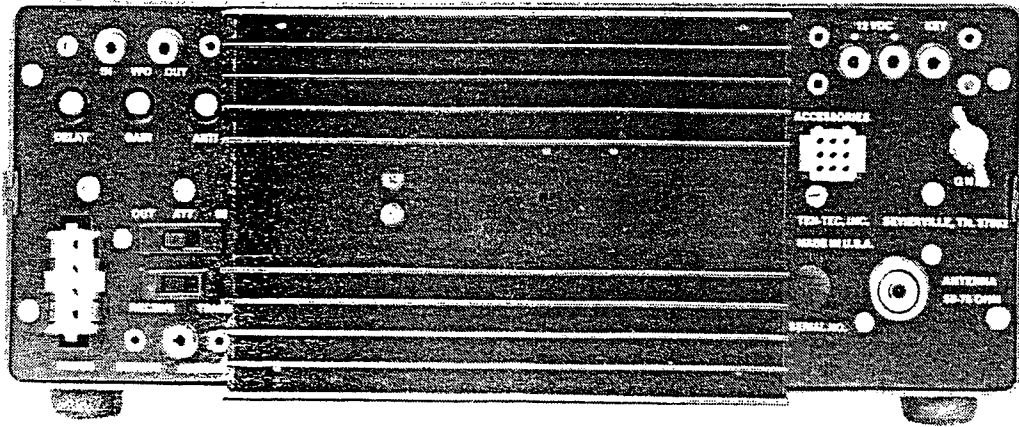
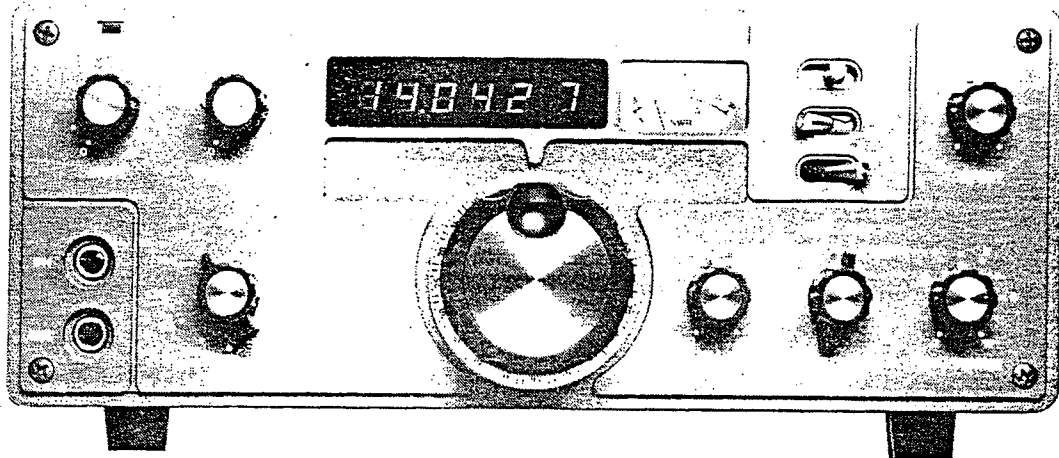

RECEIVER ALIGNMENT	5-6
TRANSMITTER ALIGNMENT	5-8
PTO ALIGNMENT	5-8
SEMICONDUCTOR PIN IDENTIFICATION	5-9
80577 PTO	5-10
80563 CRYSTAL OSCILLATOR	5-11
80560 FIRST MIXER	5-12
80553 SECOND MIXER	5-13
80554 I-F AMPLIFIER	5-15
80552 SSB GENERATOR	5-17
80555 DETECTOR/AGC	5-18
80558 AUDIO AMP/FILTER	5-20
80557 CONTROL	5-22
80562 BANDPASS FILTER	5-23
80559 LOW LEVEL AMPLIFIER	5-25
80565 FINAL AMPLIFIER	5-26
80575 BIAS	5-28
80561 LOW PASS FILTER	5-28
80566 VOX	5-30
80545 LOGIC BOARD	5-31
80549 PRESET CONTROL	5-32
80544 TIMEBASE/PREAMP	5-32
80547 DISPLAY BOARD	5-34
WARRANTY AND SERVICE POLICY	INSERT

SECTION I

UNPACKING

Carefully remove your DELTA from the packing carton and examine it for signs of shipping damage. Should any damage be apparent, notify the delivering carrier or dealer immediately, stating the full extent of the damage. Retain all damaged cartons. Liability for shipping damage rests with the carrier.

It is recommended that you keep the shipping carton and fillers. In the event that storage, moving or reshipment becomes necessary, they come in handy. Accessory hardware, etc. are packed with the DELTA. Make sure that you have not overlooked anything.

INTRODUCTION

The DELTA 580 is a medium power transceiver employing the latest techniques in solid state technology. Unique balun type transformers couple the rf power stages, insuring efficient energy transfer without the need to resonate or tune. As shipped from the factory, the DELTA contains all necessary circuits and crystals for transceiver operation in the 160, 80, 40, 30, 20, 15 and 10 meter amateur bands. (The 30 meter band, 10.10 to 10.15 MHz, is not yet available for amateur use. Operation on these frequencies at this time is illegal.) All circuits are in place for the two additional bands that will become available in the more distant future, except for the local oscillator crystals. These are the 17 meter and 12 meter bands, 18.068 to 18.168 MHz and 24.890 to 24.990 MHz respectively.

Because of its size and basic 12 volts dc transistor circuits, the DELTA is equally at home when used as a fixed, mobile or portable station. It operates directly from 12-14 volts dc or from 115/230 volts ac with the optional Model 280 Power Supply.

As you become more familiar with the operation of your DELTA, you will value the built-in features and conveniences more and more. Instant band changing completely eliminates transmitter tune-up. The panel meter automatically switches from an 'S' meter to an SWR meter when transmitting. QSK, instant break-in cw, turns this mode from a series of monologs into a conversation. These are just a few of the many features that you will enjoy. And a full array of accessories will further enhance the overall enjoyment and flexibility. All in all, the DELTA 580 is designed for active, serious amateurs.

SPECIFICATIONS

GENERAL

FREQUENCY BANDS - 1.8-2.3, 3.5-4.0, 7.0-7.5, 10.0-10.5, 14.0-14.5, 18.0-18.5, 21.0-21.5, 24.5-25.0, 28.0-28.5, 28.5-29.0, 29.0-29.5, 29.5-30.0 MHz. (18.0 and 24.5 MHz bands require optional crystals.) (VFO provides approximately 40 kHz overrun on each band edge.)

OPERATING MODES - Upper sideband, lower sideband, cw.

VFO STABILITY - Less than 15 Hz change per F° averaged over a 40° change from 70° to 110° after 30 minute warmup. Less than 10 Hz change from 105 to 125 VAC line voltage when using a TEN-TEC power supply.

TUNING RATE - Vernier. 18 kHz per revolution, typical.

READOUT - Six digit, 0.3" LED numerals. Least significant digit indicates 100 Hz.

SEMICONDUCTORS - 1 LSI, 19 ICs, 69 transistors, 6 PIN diodes, 79 diodes, 6 LED readouts, red.

CONSTRUCTION - Rigid steel chassis. Dark painted, molded front panel. Dark painted aluminum back, top and bottom. Plated tilt-up bail.

POWER REQUIRED - 12-14 V dc, 250 mA receive, 18 A maximum transmit.

DIMENSIONS - HWD 4-3/4" x 11-3/8" x 15" less bail.

NET WEIGHT - 12½ lbs.

RECEIVER

SENSITIVITY - 0.3 uV for 10 dB S+N/N, typical.

RF ATTENUATOR - 20 dB resistive.

DYNAMIC RANGE - 85 dB minimum.

SELECTIVITY - 8 pole monolithic filter. 2.4 kHz bandwidth. 2.5 shape factor at 6/60 dB. Four position switch selects standard ssb filter, standard filter with one section of audio filter, optional 200 Hz or 500 Hz cw filter, or optional cw filter with four-section active audio filter.

AUDIO FILTER SELECTIVITY - Center frequency 750 Hz. One section has 450 Hz bandwidth, down 10 dB at 400 Hz and 1500 Hz. Four sections have 150 Hz bandwidth, down 40 dB at 400 Hz and 1500 Hz.

NOTCH FILTER - Greater than 50 dB notch tunable between 200 Hz and 3.5 kHz.

FIRST I-F FREQUENCY - 11.0 to 11.5 MHz.

SECOND I-F FREQUENCY - 6.3 MHz.

I-F REJECTION - 160 Meter 95 dB; 80 Meter 95 dB; 40 Meter 90 dB; 30 Meter 40 dB; 20 Meter 80 dB; 15 Meter 75 dB; 10 Meter 70 dB.

ANTENNA INPUT - Low impedance, unbalanced.

AUDIO OUTPUT - 1 watt at 8 ohms, less than 2% HD. Built-in speaker.

SPURIOUS RESPONSES - All below equivalent 10 dB S+N/N except 10.133 MHz @ 15 dB, 28.111 MHz @ 13 dB, 28.555 MHz @ 12 dB, 29.000 MHz @ 10 dB.

S-METER - Automatically switched on when receiving.

OFFSET TUNING - Receiver, \pm 1 kHz, typical.

WWV - Reception at 10 MHz.

NOISE BLANKER - Optional accessory, Model 289.

TRANSMITTER

MAXIMUM INPUT POWER - 200 watts, ssb and cw. 100% duty cycle for up to 20 minutes, all bands.

RF POWER OUTPUT - 85-100 watts, typical.

OUTPUT IMPEDANCE - 50 ohms, unbalanced.

MICROPHONE INPUT - High impedance crystal, ceramic or dynamic.

T/R SWITCHING - VOX or PTT on ssb. Instant break-in on cw.

CW SIDETONE - Internally generated. Adjustable tone and volume independent of front panel audio control. Operates in cw mode only.

SSB GENERATION - 6.3 MHz, 8 pole monolithic filter. Balanced modulator.

CARRIER SUPPRESSION - 50 dB minimum.

UNWANTED SIDEBAND SUPPRESSION - 50 dB minimum at 1 kHz tone.

SPURIOUS OUTPUT - Less than -45 dB.

METER - Indicates SWR on transmit.

CW OFFSET - 750 Hz, automatic.

ALC CONTROL - Adjustable threshold, with LED indicator.

FRONT PANEL CONTROLS

BAND Switch; Main tuning knob; AF gain; POWER switch (pull-off);
SELECTIVITY switch; NOTCH; OFFSET (detent center); MODE switch;
ALC threshold; TX-ON switch (pull-on); PHONE jack; MICROPHONE jack.

REAR PANEL CONTROLS AND CONNECTORS

Controls: VOX DELAY; VOX GAIN; ANTI-VOX; ATTENUATOR IN-OUT switch;
RECEIVE-TRANS switch.

Connectors: ANTENNA; RECEIVE ANTENNA; KEY; ACCESSORIES; POWER input;
12 VDC jacks (2 auxiliary); GND post; VFO IN-OUT jacks (2 for remote).

SECTION II

INSTALLATION

GENERAL

Choose an operating location that is dry and cool. Allow adequate ventilation around the heat sinks on the rear panels of both transceiver and power supply. For normal intermittent transmissions, such as ssb and cw, natural convection cooling is all that is required. When transmitting for long periods of time and with a high duty cycle, such as RTTY and SSTV modes, it is recommended that a small fan be directed at the heat sinks to improve heat flow away from them. During mobile operation, free access to cool air should be available to the heat sink also. Do not direct the outlet vent of the automobile's heater directly at the DELTA.

To reduce the possibility of stray rf pickup on interconnecting cables, which may cause parasitic oscillations, and provide a measure of safety to the operator from possible shock in ac powered systems, all station equipment should be well grounded to earth. It is also important to strap the equipment chassis together with short heavy leads, preferably with braid. This procedure brings all metal components that are accessible to touching to the same potential, removing the possibility of shock when touching more than one piece of equipment. Also, the extra strap between transceiver and power supply chassis serves to reduce voltage drop on the negative 12 volt supply lead caused by resistances in the lead and connector contacts. In mobile installations, connect a ground strap between the rear panel GND post and the automobile chassis (dash board if metal). Earth ground leads should be of heavy wire or braid and be as short and direct as possible. (A ground lead that is one quarter wavelength long at the operating frequency will not bring the chassis to ground potential at this frequency, even though it will to dc and other frequencies.)

FIXED STATION INTERCONNECTIONS

POWER REQUIREMENTS

A supply of 12 to 14 volts dc, capable of supplying 18-20 amperes, negative ground, is required. The DELTA may be operated directly from an automobile type storage battery in fixed locations, provided that the voltage under full 18 amperes drain does not fall below 11 volts. This requirement dictates that the battery be near full charge and that the internal resistance be low (a relatively new battery). It is permissible to connect a slow charger across the battery to maintain the full charge condition. However, if the charger is left across the battery during operation, and if the voltage falls below the minimum of 11 volts due to age, some unfiltered ac ripple from the charger may be supplied to the DELTA, which may cause slight amplitude modulation of the transmitted signal at the line frequency. If relatively short periods of use are common, it is recommended that the charger be disconnected while operating. In all cases of battery operation, Model 1140 Circuit Breaker should be used in series with the +12 volt lead to provide over-current protection.

For 115 or 230 volt ac installations, a well regulated supply is required. Any TEN-TEC 18 ampere supply will satisfactorily power the DELTA. Models 280 and 255, both with over-current and over-voltage protection are recommended.

POWER CONNECTIONS

Power is supplied to the DELTA by means of the four terminal AMP Universal MATE-N-LOC connector. The chassis connector is of the male type and mates directly with the cable connector supplied and attached to Models 280 and 255 supplies. It is only necessary to insert cable connector into chassis receptacle. When using TEN-TEC supplies with detachable cables (e.g. Models 252M, 252MO, 262M, etc.), the connector with the green color dot mates with the DELTA chassis connector. The orange coded connector mates with the power supply chassis receptacle.

When used with TEN-TEC supplies, the power on/off function is controlled by the front panel POWER switch on the DELTA. The POWER switch on the supply must be left in the 'on' position at all times, otherwise the supply will not be energized. The two switches are connected in series with the incoming ac line to the transformer primary winding.

When using a dc source other than a TEN-TEC power supply, it will be necessary to construct a power cable using the accessory AMP connector supplied with the DELTA. Wires for carrying the 12 volt current should be at least 14 gauge copper, with 12 gauge recommended. Leads should be kept as short as possible to reduce line voltage drop. Pin connections for the power socket are: Pin 1 = GND; Pins 2 and 3 = ON-OFF switch; Pin 4 = +12 to 14 V dc. Pin 1 has a rib on the plastic part of the cable connector and Pin 4 has a rib on the chassis connector.

When using power supplies that do not have remote on/off switching capabilities, pins 2 and 3 of the connector need not be used. The transceiver must then be turned on and off with the power supply switch. It is recommended that Model 1140 Circuit Breaker be used in these instances.

With battery installations, the same precautions on wire size and length must be heeded. The switch on the AF control in the DELTA is not rated high enough in current carrying capacity to be used to switch the 12 V dc line directly. The Model 1140 breaker can be used as the power on/off switch in these installations. Pins 2 and 3 again need not be used.

The AMP Universal MATE-N-LOC connector is intended for high production with automatic staking of the wire leads to the pin terminals. However, it can be assembled in the field without staking machinery by crimping and soldering the leads to the terminals, and then inserting the terminals into the plastic shell. To do this, refer to the detail drawing below and proceed as follows:

1. The terminals are supplied connected to a strip of flat metal. Break the individual connectors from the strip by bending back and forth at the point of narrow attachment, or by clipping them off with diagonals.
2. Wire sizes that can be accommodated range between 12 and 18 gauge. Strip insulation 1/4" back from end.
3. Insert stripped end into barrel far enough so that insulation just starts between large thin and small wide tabs.
4. With long nose pliers, roll over small wide tabs so that they hold bare wire.
5. Solder leads to rolled tabs by applying iron tip to top of rolled tabs while feeding rosin core solder between wire and tabs. Do not allow solder to run down into hollow tube.
6. After terminals are well soldered, roll large thin tabs down over insulation and crimp with pliers.
7. Insert terminals into plastic shell from solid plastic end so that they finally locate in individual tubes. The terminals will automatically lock into place when inserted to the proper depth. MAKE ABSOLUTELY CERTAIN THAT TERMINALS ARE INSERTED INTO CORRECT HOLES SINCE REMOVAL IS DIFFICULT.

To remove terminals, an extractor is necessary to collapse the lanced holding tabs on the sides of each barrel. The extractor can be a metal tube, at least one half inch long, with an outside diameter between 0.125" and 0.135" and an inside diameter of 0.100". Insert the extractor tube into the pin end of the shell, over the terminal to be removed, to a depth of about 1/2". Pull on wire and extract terminal.

Additional connector kits are available from TEN-TEC at \$1.00 each with a minimum order of \$2.00. When ordering, ask for AMP 4 pin MATE-N-LOC Cable Connector and specify male or female terminals.

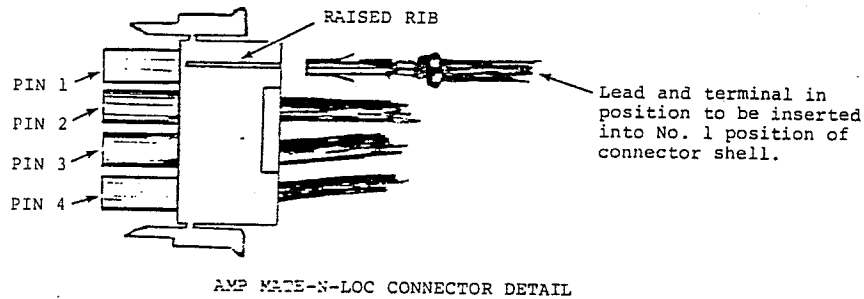
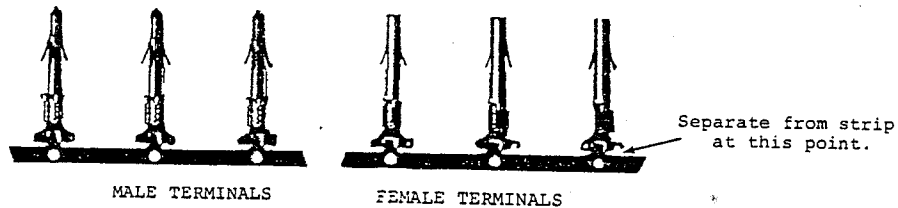

Complete the power connections by plugging line cord of power supply into wall socket and interconnect DELTA and power supply chassis with short heavy grounding wire or braid.

ANTENNA CONNECTION

Any matched antenna presenting 50 to 75 ohms impedance, one side ground, will load satisfactorily. Random length wire antennas and open wire feed systems will require a matching system such as the TEN-TEC Model 247 Antenna Tuner. Use coaxial cable between the DELTA and 50 ohm antenna or output side of the tuner. If an antenna tuner is used, locate it as far as is practical from the immediate transceiver location. Do not place tuner on top of transceiver or close to microphone, key or other cables going to the DELTA or associated accessories.

A type PL-259 coaxial connector is required to connect the antenna to the DELTA socket marked ANTENNA. The center conductor is connected to the pin and the shield braid to the shell of the connector. If the same antenna is to be used for both transmit and receive, set the RECEIVER/TRANS switch to the TRANS position.

If a separate receiving antenna, a transverter or an instant break-in type linear amplifier is to be used, the separate receiver input is marked RECEIVER ANTENNA on the DELTA rear panel. When using this input along with the main ANTENNA connector, place the RECEIVE/TRANS switch in the RECEIVE position. The RECEIVE ANTENNA jack requires a RCA phono type connector.

KEY CONNECTIONS

For cw operation a straight key, bug or electronic keyer may be used with the DELTA. For proper transmitter operation, the key line requires a very low resistance path to chassis, with no appreciable voltage across it. These conditions are easily met with straight keys and bugs. With electronic keyers however, several precautions must be observed to insure proper keying. First, all keyers with relay output configurations will work satisfactorily. With transistor switched keyers, two conditions must be met. First, the keyer switching circuit must be for low voltage, positive voltage key lines. The DELTA line has approximately 2.5 volts, positive, on it in the key-up condition. The switch transistor in the keyer output circuit must be an NPN type. The second condition for proper keying with electronic keyers is that the key-down voltage be very low -- in the order of 0.2 volts maximum. Some electronic keyers have diodes in series with the output key line, or high saturation voltage transistors. Either of these conditions raises the key-down voltage to a value higher than the minimum required. All TEN-TEC keyers, both reed relay and transistor types, will key the DELTA satisfactorily.

If your keyer does not have the required parameters as outlined above, you still may use it by having it key a reed relay acting as an interface between keyer and DELTA.

The KEY jack on the DELTA is a RCA phono type connector. Use shielded coaxial cable such as miniature type RG-174U. In cases where power for the keyer is required, such as for the TEN-TEC KR-5A, 645 and 670 models, +12 volts may be obtained from one of the auxiliary +12 VDC jacks located next to the KEY jack. Shielded coaxial cable is recommended for this connection also, if the cable is not already a part of the keyer.

MICROPHONE CONNECTION

The DELTA microphone input circuit will accept any high impedance crystal, ceramic or dynamic microphone. Transistorized microphones may also be used, provided that their output levels be adjusted low enough so that the input stage of the first microphone amplifier is not overdriven. Also, this type of microphone is more susceptible to rf pickup and may require better cable, connector and microphone shielding. It is not recommended that plastic cased transistor microphones be used because of this.

The microphone input connector is a standard three wire stereo 1/4" diameter phone plug. The microphone plug connections are shown in the detail drawing below. All leads should be shielded for most reliable and rf-free operation. The signal lead must be shielded in any case.

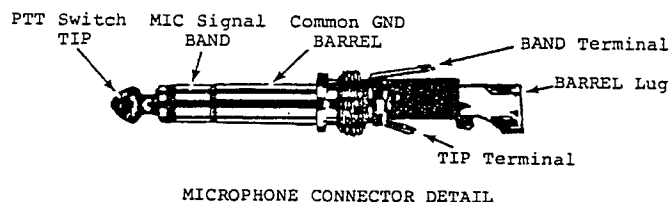

Since the crystal 8 pole filter system is common to both receiver and transmitter circuits, audio signals picked up by the microphone while receiving may be applied to the audio receiver system, causing possible acoustic howl or reverberation. To completely eliminate this in the PTT mode of switching, it is recommended that a SPDT type switch be used in the microphone and that the microphone signal lead be shorted to ground during receive. When using the VOX mode, the microphone PTT switch will necessarily have to be opened, so some microphone pickup may be apparent in the received audio. To keep this to a minimum, do not place the microphone close to the DELTA speaker.

The PTT switch works with respect to chassis. When transmitting, the switch is closed. TEN-TEC Models 215P and 215PC microphones have SPDT PTT switches.

If the TEN-TEC Model 234 Speech Processor is used with the DELTA, make sure that the +12 volts that are required to power the processor are drawn from one of the +12 VDC auxiliary jacks on the DELTA and not from the power supply directly. Failure to observe this requirement will result in instability and distorted audio due to an input groundloop being created in the microphone circuit.

REMOTE VFO CONNECTIONS

If Model 283 Remote VFO is to be used, remove the VFO IN-OUT jumper plug on the DELTA. Connect both phono plugs and the ACCESSORIES plug from the VFO's attached cables to the appropriate connectors on the DELTA. Refer to Model 283 instructions for details.

If the DELTA is to be used without the external VFO, it is necessary that the jumper plug be re-inserted.

MOBILE STATION INTERCONNECTIONS

POWER CONNECTIONS

Power requirements for mobile operation are the same as those outlined for fixed station installations. When operating mobile, a power input cable will have to be constructed using the extra AMP connector supplied. Construction details are given in the previous paragraphs. Since the DELTA AF-POWER control switch cannot be used for the on/off function, and since over-current protection is desirable, the Model 1140 Circuit Breaker, connected in series with the +12 volt lead will serve both purposes.

The maximum current drain of approximately 18 amperes is substantial enough to warrant special care to keep cable losses to a minimum. A separate set of 12 gauge or larger wires should be run directly from the battery terminals to the DELTA, with the circuit breaker in series and located near the transceiver. Only automobile systems with negative ground polarity should be used with the DELTA. Do not rely on the chassis to provide the negative connection, but run a wire directly from the negative terminal of the battery to the DELTA power connector.

ANTENNA CONNECTIONS

Most mobile antennas are designed to provide a near optimum match to a 50 ohms input. In some cases, additional matching components may be required to achieve this match. Since whip mobile antennas use the automobile's body as the ground plane, it is important that the shield of the coaxial cable at the base of the antenna be connected to a good chassis point. Trunk lids and some bumpers may require additional bonding to the main chassis with flexible straps or braid.

Resonating the whip antenna at the operating frequency is relatively easy since the SWR bridge is built into the DELTA. With reduced DRIVE - enough to provide some meter deflection - and with the TX-ON knob pulled out and mode toggle switch in the 'CW' position, the resonant point can be determined by running across the band and noting the dip in meter deflection. To insure a low power level during these adjustments, set the ALC control fully CCW. The length of the whip can then be altered to bring the dip to the desired frequency. When there, set the ALC control fully clockwise and increase DRIVE to the point where the ALC indicator lights, at which point the SWR can be read from the meter. If it is above two to one, a better match can be achieved by connecting a small capacitor across the antenna transmission line at the base of the antenna. For single band operation, the value can be determined and the capacitor permanently soldered in place. For multi-band operation, a rotary switch in a small box can be located near the antenna base, in the trunk for instance, and the proper capacitor selected in this manner. Use mica capacitors with at least 500 volts ratings. Typical values for 80 meters may be in the range of 470 pF to 1000 pF. For 40 meters, 270 to 820 pF, and for the higher bands, proportionately smaller values. Addition of the capacitor will require a small touch-up in antenna length.

Although the noise blanker accessory for the DELTA is effective in reducing ignition noise, it is best that the installation be such that ignition noise is reduced as much as possible. Use of resistor spark plugs and noise suppressors in the distributor circuits are very effective in reducing interference. Also, strap the hood to a good chassis point with flexible metal or braid if it is not already well grounded. Locate the antenna as far as is practical from the engine - either on the rear trunk deck or bumper. And since the muffler and exhaust system of most cars are supported and effectively insulated from the chassis with rubber-shocked brackets, they may carry ignition noise currents to the antenna location at the rear of the automobile. Strapping the tail pipe or muffler to the chassis at this location with flexible braid may substantially reduce ignition pickup.

The remaining interconnections for microphone, key, etc. in mobile installations are the same as for fixed stations and need not be repeated here.

SECTION III

OPERATION

CONTROLS AND THEIR FUNCTIONS

All operating controls are readily accessible on the front panel. They are grouped according to functions such as receive, transmit, tuning and band selection, and overall mode selection. The VOX controls, which only require presetting for a given installation, are located on the rear panel. Sidetone level and pitch controls, also of the set-and-forget type, are accessible through a cutout in the bottom cover.

Frequency Determining Controls

BAND Switch - This 12 position switch selects the band of operation for both transmit and receive functions. The frequencies designated on the panel, in megahertz, are the low end limits. The high end limits are 500 kHz higher than the frequencies indicated. There is an over-run of the VFO range resulting in an extension on each end of the 500 kHz range of approximately 40 kHz. Operation in these guard bands is possible with the DELTA (MARS stations for example). The new 18.0 and 24.5 MHz bands are not operational, requiring only the installation of oscillator crystals that will be available from TEN-TEC when these bands are opened for amateur use.

DIGITAL Display - The six digit readout indicates the frequency to which the VFO and BAND switch are set. Least significant digit is 100 Hz. The accuracy of the readout is dependent on the actual crystal operating frequencies compared to the design value, and the accuracy to which the counter time base oscillator is set. Crystal tolerances specified are .002% and .001%, depending on frequency, and the counter time base is set at the factory using WWV. Slight variations due to aging, temperature and the inherent crystal tolerances may cause the readout inaccuracy to range up to 600 or 700 Hz.

MAIN Tuning - This large knob with dial skirt tunes the VFO oscillator through its range of over 500 kHz. Vernier action permits precise oscillator settings. The 0 to 100 dial skirt, marked in 1 kHz increments, is friction held to the shaft and may be rotated separately from the main knob for setting it to the digital indication. Hold the plastic knob from rotating while turning the skirt with the other hand.

Since the VFO shaft is raised from chassis potential to eliminate frequency jumping caused by poor sliding contacts, there is a very small hand capacity effect on frequency when either the dial skirt or knob insert are touched. To eliminate this effect, grasp only the plastic portion of the knob, or use the finger spinner depression when fine tuning the VFO.

Mode Selection Controls

LSB-CW-USB Switch - This three position toggle switch selects lower sideband (LSB), cw or upper sideband (USB) operation. When in either of the sideband positions the keying circuits are disconnected so that accidental closing of the keyer paddle will not cause the DELTA to switch into the transmit mode. When the switch is in the 'CW' position, the microphone PTT switch and VOX are inoperative. In cw, the sidetone circuits are activated.

VOX-PTT Switch - This two position toggle switch selects the mode of transmitter switching, either Voice Operated (VOX) or Push-To-Talk (PTT). When using VOX, the PTT switch on the microphone must be in the 'transmit' position in order that the VOX circuits receive the microphone signal.

OFF-NB Switch - When Model 289 Noise Blanker is installed, this toggle switch activates its circuits in the 'NB' position. The switch position is unimportant if the blanker is not installed.

Receiver Controls

AF-POWER Control - Adjusts level of received audio from speaker or headphones. Does not affect level of sidetone when operating cw. The POWER switch is a push-pull type and shorts pins 2 and 3 together in the AMP chassis connector when pushed 'in'. It is not connected in the input +12 volts supply lead.

SELECTIVITY Control - This four position switch determines the passband of the receiver. In the SB-1 position the eight pole monolithic crystal filter is inserted in the i-f section. It has a bandpass of 2.4 kHz for normal band conditions. The SB-2 switch position adds one section of an active audio filter to the system, centered at 750 Hz and providing slight attenuation on both sides of center. This additional filtering is useful when adjacent frequency interference is present, or when the band is noisy from either atmospheric or ignition. The CW-1 switch position inserts whatever optional crystal filter is installed in the DELTA (Models 282 or 285) in series with the 2.4 kHz standard filter. If no optional filter is installed, the CW-1 passband reverts to the SB-1 standard eight pole filter. In CW-2, the optional filter, if installed, is enhanced with the addition of four stages of active audio filtering whose center frequency is 750 Hz and bandwidth at the 6 dB points is 150 Hz. Without the optional i-f crystal filter installed, CW-2 inserts the four stage audio filter in series with the 2.4 kHz filter.

NOTCH Control - This control determines the frequency within the audio spectrum between 200 Hz and 3.5 kHz at which a sharp null in response is inserted. The frequency at which the null occurs increases as the control is rotated clockwise, and in the full clockwise position (OUT) it is beyond the receiver's highest audio limit and is effectively removed from the circuit. The notch is very useful in removing in-channel QRM carriers or interfering cw stations, or in reducing in-channel ssb interference to some degree. Since the null is very sharp and deep, careful adjustment of this control is required for maximum rejection.

OFFSET Control - This control permits moving the receiver frequency approximately 1 kHz above and below the transmitting frequency. Clockwise rotation from the detented center position increases frequency and counterclockwise rotation reduces frequency. When positioned at the detent the receiver and transmitter values are the same. The control is useful in situations where several stations are being worked in a roundtable and all are not exactly on the same frequency. The received station can then be 'zeroed in' with the OFFSET control without upsetting the frequency of your transmissions. Also, it is very useful when working DX stations when they purposefully transmit slightly higher or lower than they receive.

PH Jack - This phone jack is the external headphones or speaker connection. When employed, the internal speaker is automatically disconnected from the audio amplifier. Although the amplifier is designed for an 8 ohms load, external speakers between 4 and 16 ohms will work satisfactorily.

Headphones of any impedance will also work directly from this jack. However, since the amount of power required to drive headphones to a satisfactory level is much less than for a speaker, it is recommended that an attenuator be used between the PH jack and low impedance headphones. The attenuator will greatly reduce residual noise and audio feed-through when transmitting because the audio amplifier will be operating with a more favorable signal-to-noise setting of the AF control. A simple resistor network consisting of approximately 15 ohms in series with the phones and a shunt resistor of 2.7 to 3.3 ohms across

the phones should suffice. The resistors, both 1/4 watt types, can be soldered to the phone plug terminals and concealed in the shell of the male plug. The attenuator is not necessary with high impedance headphones due to the self-limiting power aspect of connecting a high impedance across a low impedance, constant voltage line.

Transmitter Controls

DRIVE Control and Indicator LED - The DRIVE control adjusts both the microphone gain and the cw drive to the rf amplifier. For ssb, advance the control under normal speech operation until the LED indicator lights on voice peaks. For cw, advance the DRIVE control until the LED lights in key-down condition. The setting will be the same for dits, dahs or continuous signal. When operating cw, the DRIVE setting may be made in the TX-ON switch position. However, this setting does not hold for ssb since microphone type, closeness to your lips and loudness of speech all determine the proper ssb DRIVE setting.

Once the LED begins to light, further advancement of the DRIVE control will not materially increase output power, but will adversely affect cw keying characteristics or ssb intelligibility.

ALC-TX ON Control - This control is a combination variable adjustment and a push-pull switch. The switch, when pulled out, turns the transmitter on in the same manner as when operating in the cw mode, key down. The LSB-CW-USB switch should be in the 'CW' position. It provides a continuous carrier to the antenna at the frequency indicated on the digital display and at a level determined by the settings of the ALC and DRIVE controls. It is useful in tuning antennas or checking SWR.

The ALC portion of the control sets the threshold level at which the output rf power is limited in value. In the full clockwise position, the maximum factory set input power of 200 watts is achievable, resulting in output power of approximately 90 watts, more or less, depending on frequency and transistor efficiency. This occurs when the DRIVE control is advanced so that the ALC indicator above the DRIVE control begins to glow. Input power can be reduced below this level to approximately 50 watts when the control is rotated counterclockwise. A change in the setting of the ALC control requires a readjustment of the DRIVE control.

The control enables the user to set the power level below its maximum while still retaining ALC control, in cases such as when driving high power linears that do not require the full output capabilities of the DELTA, or if antenna SWR is so high that power supply demands are exceeded, or when reliable communications can be attained at reduced power levels.

VOX Controls - The three VOX controls on the rear panel need be set only once for any given station installation. They are not inter-related with the cw instant break-in circuits and therefore do not need re-adjustment when going from ssb to cw or vice versa. To accurately adjust these three controls (GAIN, DELAY and ANTI) proceed as follows:

1. Adjust AF control and all VOX controls fully CCW.
2. Set VOX-PTT switch to VOX position and connect microphone to MIC jack. Make sure PTT switch on microphone is in 'transmit' position.
3. Adjust GAIN control clockwise to point where reliable T/R switching is attained with normal conversational voice level while speaking into microphone held twice normal distance from mouth.
4. Readjust AF control for comfortable receiving level of incoming station.
5. Without speaking into microphone, adjust ANTI control for elimination of sustained tripping action caused by speaker signals feeding into microphone. Microphone should be in approximate location typically used when transmitting.

6. Set DELAY control clockwise so that T/R switching does not occur between words and phrases when speaking into microphone.

MIC Jack - Three wire, two circuit phone jack for microphone input. Connections are outlined in previous section.

SIDETONE Controls - The two sidetone adjustments, level and pitch, are accessible through the small round hole located in the bottom cover of the DELTA. They are printed circuit types mounted vertically side by side. The control farthest to the right side of the DELTA is the level adjustment.

OPERATING HINTS

1. The movable bail is primarily intended to raise the front panel to a convenient slanting position. In this position the speaker output is effectively radiated forward due to the 'V' formed by the DELTA bottom and the table.
2. The DELTA may be operated as a QRPp transceiver by adjusting the DRIVE control downward. To determine input power, insert a dc ammeter in the +12 V line. (Meters are included in TEN-TEC power supplies.) For every ampere increase over the no-drive quiescent value, measured in cw mode with the TX-ON knob 'out', the power input to the final amplifier is increased by about 13 watts. For example, assuming a quiescent current of 2 amperes, a 4 ampere reading on the ammeter indicates 26 watts input.
3. The S-Meter is factory calibrated for a 50 uV input signal reading of S9 on the 14 MHz band.
4. To determine SWR, set ALC control fully clockwise, TX-ON switch 'out', LSB-CW-USB switch to 'CW' and DRIVE so that indicator LED lights. Read SWR on lower meter scale.
5. Increasing the DRIVE control beyond that required to just light LED will not result in any appreciable increase in power out. However, overdrive may increase ssb distortion and destroy cw keying characteristics.
6. Due to the possibility of high voltage transients being generated in the output rf amplifier during bandswitching, changing bands should not be done while transmitting power to the load. Either place the DELTA in the receive mode or be certain of a key-up condition in cw. YOU RISK THE POSSIBILITY OF DESTROYING THE OUTPUT TRANSISTORS IF THIS PRECAUTION IS NOT OBSERVED.
7. Although improper antennas will not damage the final, we suggest an SWR below 3 to 1 be achieved for maximum performance. In cases where the antenna cannot be matched to a better SWR, and the TEN-TEC power supply repeatedly shuts down due to over-current conditions, the DELTA may be operated at reduced input power by rotating the ALC control CCW to a position where the supply draws less than 18 amperes.
8. When operating mobile, always turn DELTA 'off' when starting the engine. High voltage transients from the generator may appear on the supply line before the regulator contacts close.
9. To determine the exact frequency of an incoming cw signal, tune the receiver to 'zero beat', not to a maximum S-Meter deflection, before reading digital display.
10. To transmit your cw signal on the same frequency as the incoming signal, set OFFSET control to center position and peak the incoming signal on the S-Meter. The peak will be more discernable if the optional CW filter is installed or if the SELECTIVITY switch is in the CW-2 position. Since the filter is centered at 750 Hz and the transmitter frequency in cw is offset 750 Hz from the received frequency, peaking the incoming signal correctly sets up the transmitter.
11. Since the digital display reads the actual transmit and receive frequencies, and since the transmitter frequency in the cw mode is automatically offset

by 750 Hz, the display will appear to be unstable when sending code. This is normal and caused by the counter reading two different input frequencies. The same condition exists when the OFFSET control is other than at the center position.

12. WWV can be received on the 10 MHz band. When its carrier is set to 'zero beat' the digital display should read 10.000 0. If it doesn't, the counter time base can be readjusted.

AN IMPORTANT MESSAGE

In order to obtain top performance from your DELTA, we feel that you should be briefed on new technology such as solid state no-tune rf amplifiers. Misconceptions sometimes arise from incomplete knowledge which result in erroneous conclusions being drawn that the equipment is faulty, erratic or not performing to specifications. It is the purpose of this message to inform you in these areas so that you can knowledgeable approach and correct any apparent improper performance characteristic.

Ten Points To Observe When Installing The DELTA

1. The transmitter will give best performance when properly loaded.
2. Even though the output transistors are resistant to damage from improper loads, they will not operate satisfactorily under all load conditions and will not operate to specifications.
3. The output transistor dissipation will increase if the DELTA is not properly loaded.
4. Reactive impedances in the antenna are applied to the transistors and may cause parasitic oscillations.
5. A given SWR reading does not tell you anything about the reactive components and is not accurate unless the load is a pure resistance.
6. A given SWR indicates one of two possible impedances. Each acts differently on the transceiver's performance.
7. The most efficient operating point is when the load is 50 ohms, resistive.
8. The ALC light is not an indication of the input power but of the output power. It may not light even though the power supply is delivering enough current to trip the breaker.
9. If the breaker repeatedly trips, it is an indication that the load is enough removed from the optimum so as to cause high transistor dissipation.
10. It is possible for the power supply regulator to drop out of regulation just prior to its tripping the breaker with low ac line voltages (brown-outs or long ac power runs). Under these conditions, hum modulation will appear on the transmitted signal. With proper load and line voltage, the current drain will be considerably below the tripping point so no hum should appear on the carrier.

Technical Facts Of Life

Although vacuum tubes and transistors can amplify rf power, there are some fundamental differences in how this is accomplished. We are all familiar with vacuum tube principles, but not with those of transistors. A better understanding of what we can expect under various operating conditions will aid in recognizing correct or incorrect performance.

1. Broadband vs Resonant Tanks - Almost all tube circuits use resonant tanks in the plate circuit. The DELTA uses a broadband system. In class AB operation, these two approaches act similarly without drive being applied. The idle current is relatively low and within the device dissipation rating, even though load impedances may range from open to short circuit.

However, with drive applied, the two act very differently. In the case of tubes the dissipation within the tube depends on both the tuning of the tank and the load applied. If the tank is resonated and the load is very light, the internal power dissipated is quite small as indicated by the deep null in plate current which reduces its value to a level approaching that with no drive. Out of resonance, the plate current, and hence dissipation, increases rapidly and may damage the tube from overheating. In resonance, as the load is increased, the null becomes more shallow at a higher plate current. This increase is a result of more power being delivered to the load. As the tank is tuned to resonance, the load impedance which is usually on the order of 50 ohms is transformed to a relatively high impedance of several thousand ohms to match the plate circuit impedance. Small load reactive components - either capacitive or inductive - can usually be balanced out in the tank resonating function.

With transistors, drive applied and with no load, there is no resonant high impedance to limit the collector current, and so power is poured into the circuit (much as the out-of-resonance tank condition). Since there is no load, all of the power has to be dissipated in the transistors. So even with no load, the power supply circuit breaker may trip. The broad-band transformer system used with transistors transforms the 50 ohms load impedance not higher but much lower (in the order of 4 or 5 ohms) to match the transistor output impedance. Since this transformation is fixed in design, any reactive component in the load impedance is applied in a transformed way to the collector circuit. Certain reactances at this point, especially inductive, give rise to parasitic oscillations. To correct for this, the antenna impedance should be changed to remove this reactance, or a matching network should be inserted between antenna and transceiver. It is important to remember that any antenna changes its impedance with frequency, so that one that resonates well at one end of the band may well cause oscillations to trip the circuit breaker on the other end. If entire band operation is desired, especially on the lower bands, the adjustable matching network would be the better choice, rather than to try to make the antenna behave over the entire band on a cut-and-try basis.

A final point to bring out regarding broadband vs tank systems is that there is a limit to the amount of current you can draw from an emitting filament, and this saturation current will limit the amount of power drawn from the supply. In the case of transistors, where the collector internal impedance is only a fraction of an ohm, extremely high currents can be demanded from the power supply, especially with mismatched loads well below 50 ohms. A fuse is provided in the DELTA for protection when operating from a power source that is not limited. Because of their slow action in opening the circuit, better protection is provided with an electronic circuit breaker or with Model 1140 fast acting magnetic breaker. TEN-TEC power supplies have current limiting circuits.

2. SWR-Two Kinds - The standing wave ratio is a direct measure of the ratio between two impedances, i.e. an SWR of 3 to 1 tells us that one impedance is three times the other. Therefore, the unknown impedance can be either three times larger or three times smaller than the known one. If the desired impedance that the transceiver wants to see is 50 ohms, an SWR of 3 to 1 on the line may mean a load impedance of either 150 ohms or one of 17 ohms. If it is 150 ohms, the transmitter will act differently than if it is 17 ohms. In the first case, the power demanded from the supply will be much lower, and will not be large enough to trip the breaker. In the second case, even though the SWR reads the same, the supply may repeatedly trip out. The SWR reading gives no indication of reactive components, nor can it separate the resistive from the reactive components. It is calibrated with a pure resistive load and therefore has its greatest accuracy with a pure resistive load. The SWR bridge should only be used as an indicator when attempting to adjust the antenna system to a pure 50 ohms resistive impedance at the transmitter output point.

3. Efficiency - Since transistor amplifiers have a very low value of output impedance, they act more or less as a constant voltage source. That is, the rf output voltage tends to remain at a fixed level regardless of the load impedance. Hence, the output power will vary depending on the value of the load, and increase as the load impedance decreases. It can be seen that a 3 to 1 SWR on the low side of 50 ohms will ask the amplifier to deliver much more power than a 3 to 1 SWR on the high side. Since the amplifier does have a finite value of output impedance, the amount of power delivered efficiently to the load will change with load value. Unless the load is near the design value, the transistors will heat up unnecessarily without delivering any more power to the antenna.
4. Protective Circuitry and ALC - ALC serves three major functions. It assures the maximum power from the transmitter without careful adjustment of the input drive, it prevents the amplifier from being overdriven into the non-linear, distortion-producing area, and it serves as a power limiting device which protects the output transistors. It does the first two very well, but the third only partially. To absolutely protect the system, we add the current limiting circuitry to the power supply, or a fast acting magnetic circuit breaker in the dc supply line.

The ALC system senses the power output and adjusts drive accordingly. Note that it does not sense the power into the final. Therefore some load conditions may exist where the ALC system will not limit transistor dissipation. One instance is when there is a highly reactive load. It is not possible to make a purely reactive load absorb power, so the ALC light will not go on, even though high power is being drawn from the supply and being dissipated in the transistors as heat. Under these conditions the power supply protective circuits take over and trip the breaker. So it is very possible that the breaker will repeatedly trip without the ALC indicator going 'on'. If this occurs, it indicates a change in the antenna system or matching network is needed.

A final comment regarding this situation - when the breaker in the power supply trips, the amount of current drawn from the supply may be high enough to cause the supply to drop out of regulation, especially with low line voltage. The output may become hum modulated. This condition should be rectified by antenna and/or matching changes, or by operating at a lower ALC control setting, since the emitted quality of the signal will be poor.

If the precautions stated above are observed, we are sure that you will be more than delighted with the performance of your DELTA.

Recommended Reading

1. ARRL Handbook, Amateur Radio Relay League
2. Antenna Handbook, Ken Glanzer, Cowan Publishing
3. W8NWU Teeter Totter Tuners, Schultz, CQ Magazine, Feb. 1969, Pg. 27

IF YOU HAVE TROUBLE

SYMPTOM	POSSIBLE CURE
DELTA dead. No display or meter lamp illumination. Receiver and transmitter inoperative.	Make sure power switch is on. Check power cable from supply or battery. Check supply or battery for proper voltage. Check 20 A fuse inside DELTA. (Remove bottom cover. Fuse is near POWER connector).
20 Ampere fuse blown.	Check for reverse polarity of 12-14 volt line. Correct cable wires or connector termination.
Display shows erroneous frequencies in all BAND positions. Tuning knob has no effect on display. Seems to switch from receive to transmit but receiver and transmitter inoperative.	Make sure VFO IN-OUT jumper is in place. Check for faulty contacts on jumper.
DELTA dead. Display and meter lamps OK.	Make sure BAND switch is not in 18.0 or 24.5 positions.
Set seems alive but received signals are weak or non-existent. Transmits normally. Normal SWR.	Make sure RECEIVE/TRANS switch is in TRANS position. Make sure ATT switch is in OUT position.
Same as above but SWR is high.	Check antenna system and cables. Try dummy load to see if problem is in antenna system. Check settings of antenna tuner if used.
No sidetone. Transmits OK.	Check to see if sidetone level control is advanced far enough.
Transmitter does not come on in ssb. Normal on cw.	Check VOX settings. (GAIN, DELAY, ANTI) Check PTT switch in microphone. Check microphone cable and plug.
Receiver dead. Transmits OK.	Check to see if headphones are plugged in, disabling speaker. If bottom was removed, make sure speaker cable is plugged into PC board socket.

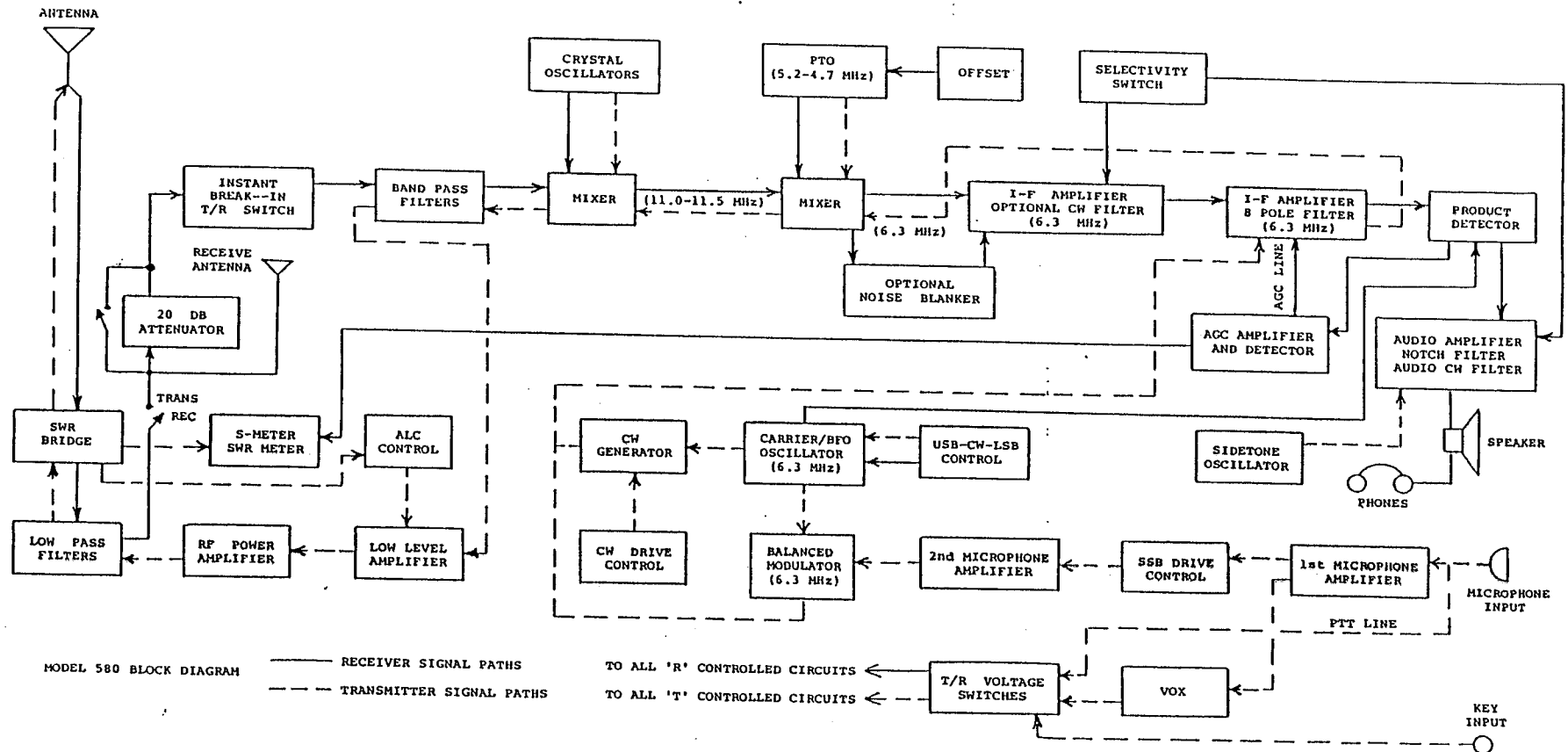

MODEL 580 DELTA
BLOCK DIAGRAM

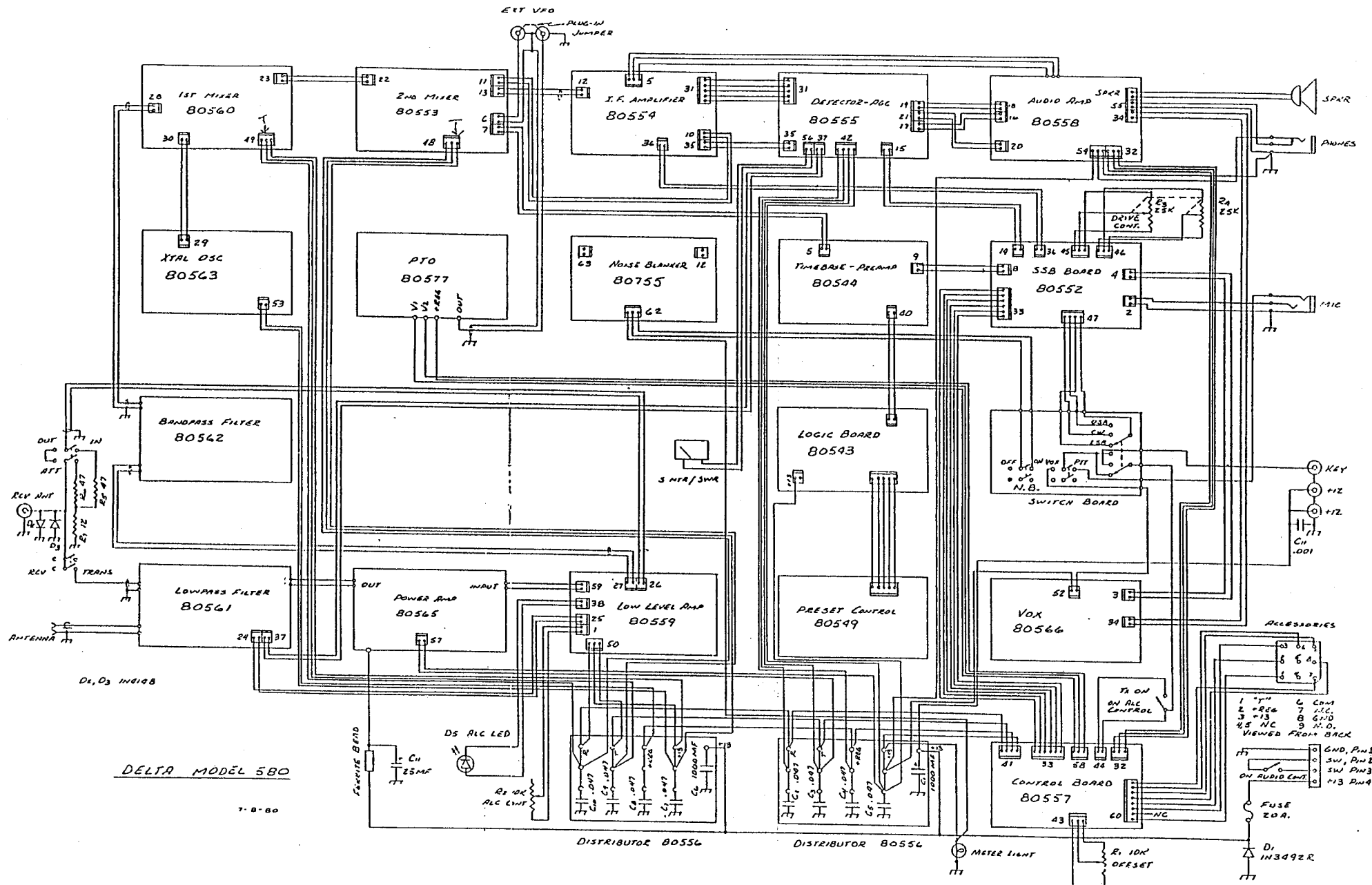

MAIN CHASSIS WIRING

SECTION IV
PRINCIPLES OF OPERATION

GENERAL

On page 3-9 is a block diagram for the DELTA transceiver. Most of the DELTA circuitry is used in both transmit and receive modes. Double conversion is used with injection voltage for the first conversion provided by a crystal controlled oscillator. A bandpass i-f 500 kHz wide is used to couple the first and second mixers. Injection voltage for the second mixer is furnished by a VFO with a tuning range of 500 kHz. The second i-f, 6.3 MHz, either feeds a product detector for the receive function, or is fed by a SSB generator for the transmit function.

The following is a description of the receive and transmit functions. Circuits that are common to both, such as oscillators, mixers, tuned circuits, etc., will only be covered in the receive section.

RECEIVER

RECEIVE RF AND MIXER CIRCUITS

The antenna is connected through the QSK switching and attenuator to the bandpass filter board. This board contains the filters, used in both transmit and receive, for each of the amateur bands plus the three proposed bands. A bilateral amplifier (used for both receive and transmit functions) follows the bandpass circuits and drives a DIODE MIXER (80560). This mixer output of 11.0 to 11.5 MHz is coupled through a three pole bandpass filter to the second mixer board (80553). Another bilateral amplifier drives the second diode mixer. The VFO is coupled to the second mixer and produces an i-f of 6.3 MHz.

OSCILLATOR CIRCUITS

All oscillator circuits are common to both receive and transmit functions.

CRYSTAL OSCILLATORS

High frequency CRYSTAL OSCILLATOR sub-assembly (80563) provides the injection voltage for the first mixer. The crystal oscillator output frequency is always 11.5 MHz higher than the lower edge of the selected band. On bands below 7.5 MHz the crystal operates in a colpitts circuit. On bands above 10.0 MHz the crystal operates in an impedance inverting oscillator. The outputs of the oscillators are then combined and fed to the first mixer.

The crystal controlled BFO and its associated circuitry is located on the SSB board (80552). Crystals Y1 and Y2 provide the proper BFO frequency relationship to the monolithic filter passband to produce the proper audio response from the product detector. Crystal Y1 (6.296) is used for lower sideband and Y2 (6.300) is used for upper sideband. This is due to sideband inversion in the first mixer.

VARIABLE OSCILLATORS

The VFO (80577) uses fixed capacitance and variable inductance to produce the required tuning range of 4.7000 to 5.2000 MHz for USB/CW and 4.7034 to 5.2034 MHz for LSB. Varactor D3 on the PTO S/A (80511) is used to adjust the oscillator to the proper range for the desired mode. With the mode switch in LSB, potentiometer R3 and transistor Q5 on SSB board (80552) set the voltage to varactor diode D3 on 80511 to produce a range of 4.7034 to 5.2034 MHz with the mode switch in USB or CW, transistor Q5 is biased on changing the voltage to varactor diode D3 and results in a tuning range of 4.7000 to 5.2000. Note

that when R3 is properly adjusted it will shift the VFO frequency by an amount equal to the frequency separation of crystals Y1 and Y2. This allows either sideband to be selected without retuning the dial.

I.F. AMPLIFIER 80554

Output from the second mixer is connected to Q1 on the I-F sub-assembly (80554). This amplifier either drives the remaining i-f stages directly or goes through the accessory crystal filter when it is selected. The remaining amplifier stages and monolithic filters are used for both transmit and receive functions. Q2 is selected in the receive mode and Q3 is selected for the transmit mode. The output for receive is fed directly to the product detector by way of connector 35. The transmit output is fed to the second mixer by way of Q7, Q8 and connector 10. Gain of the i-f system in the transmit mode is set by potentiometer R23.

DETECTOR AND AGC CIRCUITS 80555

Output from the i-f amplifier is connected to product detector Q7. Audio output from the product detector goes through the notch filter and audio filter on the AUDIO AMPLIFIER (80558) and back to i-c amplifier U1. The amplified audio is connected to the AGC voltage doubler diodes D1 and D2. The rectified output is filtered by R12, C10 and fed to Q1, Q5 and Q6. Q1 provides AGC voltage to i-f amplifier U1 (MC1350P). Q5 and Q6 drive the "S" meter circuit and pin diode D11 for additional AGC. A "HANG" AGC system is incorporated to eliminate slow recovery of the receiver when subjected to very strong signals. Transistors Q2 and Q3 back bias diode D3 during reception of signals. The AGC delay time constant during this period is set by R12 and C10. When the signal disappears, Q2 turns off (time set by R16 and C11) and provides a delay time constant set by C10, R12 and R19.

AUDIO AMPLIFIER 80558

Audio from the product detector is connected to the notch filter U3. The notch is adjustable from 200 Hz to 3.5 kHz. The signal is then fed back to the detector/AGC board or through audio filter U2 and then back to the board depending on the position of selectivity switch S1. Switch S1 also selects the accessory crystal filter on the I-F AMP board (80554). Power amplifier U1 drives the speaker or phones. CW sidetone is generated by oscillator Q2. The frequency and amplitude are adjustable by potentiometers R16 and R10.

TRANSMITTER

GENERATION - SSB BOARD 80552

Carrier (BFO) oscillator Q10 provides the proper frequencies for USB and LSB operation. The signal is buffered by Q9 and connected to balanced modulator D9, D10. Output of the balanced modulator contains both upper and lower sidebands and is coupled through connector 36 to the i-f and monolithic filter.

Microphone audio is coupled to amplifier U1A. Output from U1A is available to drive the VOX system or amplifier U1B. Output from U1B drives the balanced modulator.

The CW signal is coupled to connector 36 by way of diode gate D5 and D6. Bias voltage for this gate is provided by Q7. A keyed voltage is applied to the base of Q7 by way of CW drive control (connector 45) and R29, C36. Resistor R29 and capacitor C36 determine the CW keyed waveform shape.

Carrier (BFO) output is available through connector 8 for the counter and through 14 for the product detector.

BALANCED MIXERS AND AMPLIFIERS

The sideband signal from the i-f amplifier is connected to the second mixer and converted to 11.0 to 11.5 MHz. It is filtered by the same three pole bandpass filter used in receiving. The resultant signal is connected to the

first mixer and converted to the bands by the crystal oscillator. The output is filtered by the same set of bandpass filters used in receiving.

LOW LEVEL AMPLIFIER/ALC. - 80559

The transmitted signal from the bandpass filter is connected through pin diode D2 to amplifier Q1 and Q2. Output from Q2, approximately 0.5 watts, is connected to the final amplifier 80565.

ALC voltage from the bridge located on low pass filter 80561 is fed through connector 1 to Q9. ALC time constant is set by R10 and C14. The ALC voltage is then compared with the voltage at the base of Q6. The resultant voltage adjusts the bias on pin diode D2 and controls the gain of the transmitter. The ALC light is adjusted to come on as the ALC reduces the gain through diode D2.

POWER AMPLIFIER 80565 AND LOW PASS FILTER 80561

The low power signal from 80559 is amplified by driver transistors Q1, Q2 and final transistors Q3 and Q4. The output is connected through the appropriate low pass filter and SWR bridge to the antenna connector. ALC output voltage and SWR voltage are available through connectors 24 and 37. Potentiometer R3 adjusts the SWR indicator on the meter.

VOX 80566

Output from the first microphone amplifier is fed to the input of U1A. Output from U1A is connected to U1B through the VOX gain control. The amplified output from U1B feeds a voltage doubler D1, D2. Anti-Vox signal is taken from the audio power amplifier output. It is then amplified in U1C and rectified into a negative voltage by D3, D4. The positive voltage from the VOX detector D1, D2 and the negative Anti-Vox voltage are added and applied to U1D. The output of U1D drives the transistor switch Q1. VOX delay is set with potentiometer R19.

SECTION V
ALIGNMENT AND SERVICE

GENERAL

This section covers maintenance and service of DELTA transceivers. It includes information on trouble analysis, signal tracing and alignment procedures. The main schematic is on page 3-10 and at the end of this section are schematics and photographs of each circuit board. The usefulness of signal level and alignment data given depends upon the accuracy of the test equipment used. Except for occasional touchup to compensate for possible component aging, alignment normally will be necessary only if frequency determining components have been replaced.

When removing a particular assembly, note the orientation of the board in the chassis so that it can be replaced correctly. Many assemblies can be inadvertently inserted incorrectly if care is not taken. Figures 5-1 and 5-2 show correct placement.

To remove a board, unplug all connectors and then remove the screws fastening it to the chassis. Note the number of connectors present and the orientation of them within the wiring harness. All are keyed for proper insertion but can be forced in incorrectly. Each cable connector is numbered along with its corresponding connector on the board.

To facilitate location of the various components that may require alignment or adjustment, refer to the table below.

<u>FUNCTION</u>	<u>ASSEMBLY</u>
Receiver input coils	BANDPASS FILTER, 80562
First mixer (11-11.5 MHz)	FIRST MIXER, 80560
S-Meter adjust	DETECTOR/AGC BOARD, 80555
Counter calibration	TIMEBASE PREAMP, 80544
Offset zero adjust	CONTROL BOARD, 80557
USB/LSB carrier adjust	SSB GENERATOR, 80552
CW transmit offset	SSB GENERATOR, 80552
Carrier balance	SSB GENERATOR, 80552
USB/LSB frequency adjust	SSB GENERATOR, 80552
Sidetone level	AUDIO AMP, 80558
Sidetone pitch	AUDIO AMP, 80558
Transmit mixer null	SECOND MIXER, 80553
ALC level	LOW LEVEL AMP, 80559
SWR null	LOW PASS FILTER, 80561
SWR calibration	LOW PASS FILTER, 80561
External T/R relay delay	CONTROL BOARD, 80557
Final amplifier bias set	FINAL AMPLIFIER S/A, 80565
Driver bias set	FINAL AMPLIFIER S/A, 80565
Transmit gain adjust	I.F. AMPLIFIER, 80554

PARTS LISTS

Below most schematics is a list of the main parts on each circuit board. Common parts such as fixed resistors are readily available and are not listed.

CABINET REMOVAL

1. Disconnect all power and external connectors.
2. Remove the four side screws holding the top. Lift back of top and slide off.

- Remove the four side screws holding the bottom and the one screw on the rear of the bottom. Lift back of bottom and slide off.

NOTE: Be sure to unplug speaker cable before lifting bottom completely off transceiver.

DIAL SKIRT REMOVAL AND REPLACEMENT

The main tuning dial skirt is friction mounted to the shaft and can be easily removed by pulling it straight off the shaft after the plastic knob is removed. The felt washers between knob and skirt provide a slight amount of friction to eliminate any backlash between the two.

To replace the dial skirt, either a specially constructed tool as shown below, or a screwdriver with a blade width of approximately $9/32$ " can be used. With the tool, spread the "D" spring on the skirt hub so that the straight portion does not show through in the hub bore. If the tool tip shows in the bore, this is OK for now. Start the skirt on the shaft, with the tool handle pointing downward in relation to the front panel. This puts the handle of the tool out in the open. Push the skirt on the shaft until the tip of the tool in the hub bore hits the brass portion of the two diameter shaft. While maintaining inward pressure on the skirt, slowly remove the tool from the groove by using a rotational motion on the handle. As the tip is pulled from the hub bore, it will allow the skirt to be pushed on the shaft before the spring can regain its unstressed condition. Seat the skirt as far as it will go.

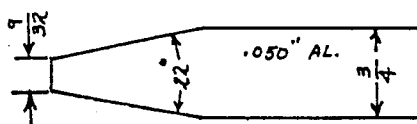

Dimensional details
of insertion tool.

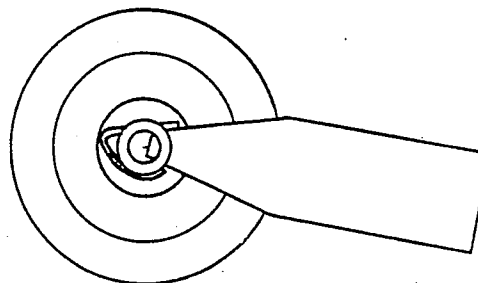

Rear view of dial skirt
with tool inserted.

REMOVAL OF FRONT PANEL

Remove top. Remove BAND and SELECTIVITY switch knobs using the 6-32 allen wrench provided. Then remove main tuning knob, dial skirt and remaining knobs using the 4-40 allen wrench. Unplug the cable connector to the ALC light in the upper left corner of front panel. Now remove the five screws holding the front to the sub-panel. Be sure to save the black decorative washers that are in front of the three toggle switches.

PILOT LAMP REPLACEMENT

The DELTA uses a single lamp mounted behind the meter. It is a standard 12 volt bayonet type, No. 1892. Access to this bulb is by removing top of unit.

FUSE REPLACEMENT

The fuse located on the back panel protects the DELTA from heavy overload and reverse polarity conditions. Replace with a 3 AG fast-blo 20 ampere type.

ROTARY SWITCH CARE

Selector switches are specially lubricated by the manufacturer for maximum life. Brushing on or dipping switch in solvents will wash away the special lubricants and shorten the life of the switch. Cleaning rosin from soldered connections is not recommended since there is a hazard of the dissolved rosin running into the switch causing resistance problems. Never use commercial contact cleaners on switches.

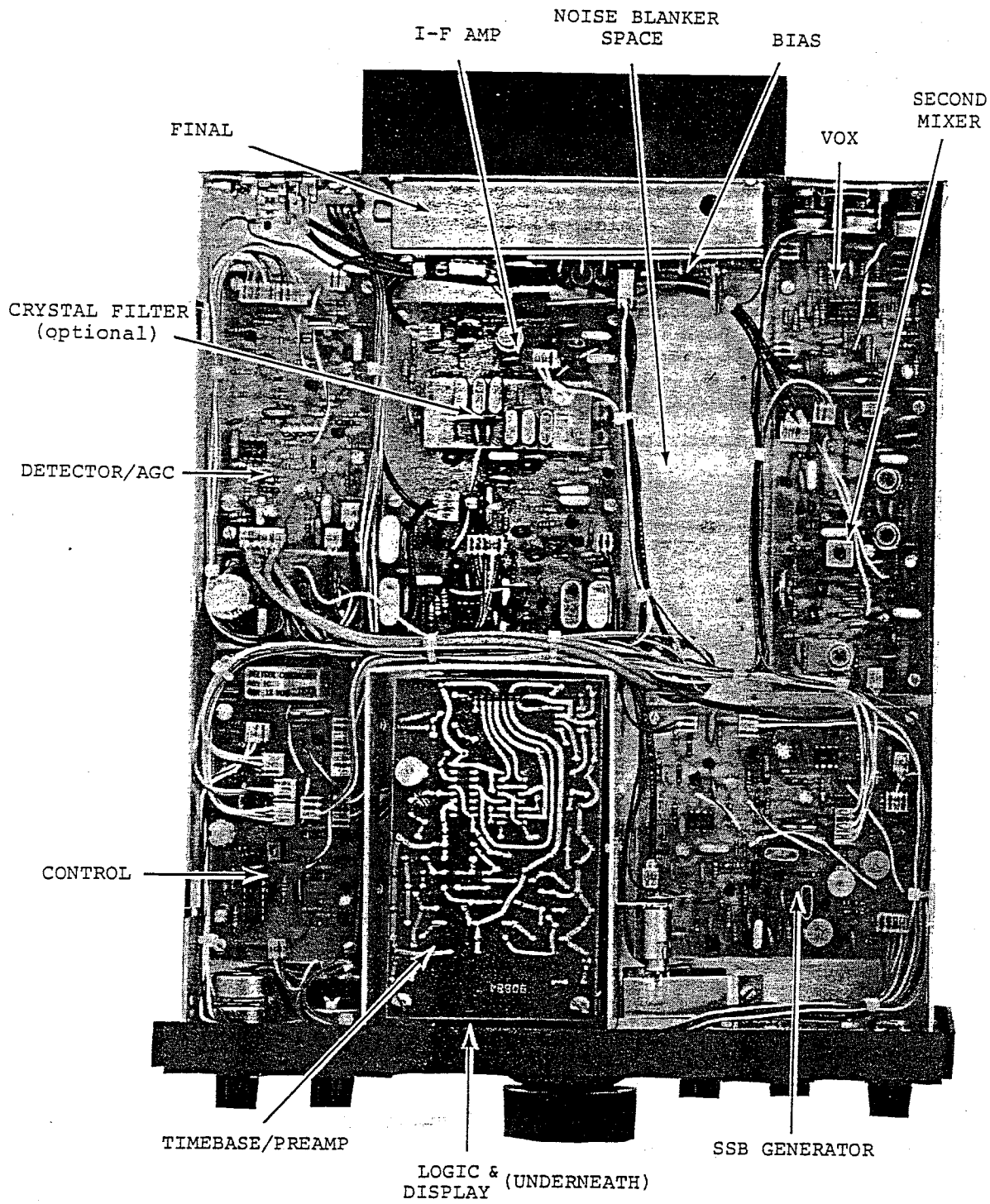

FIGURE 5-1 TOP VIEW

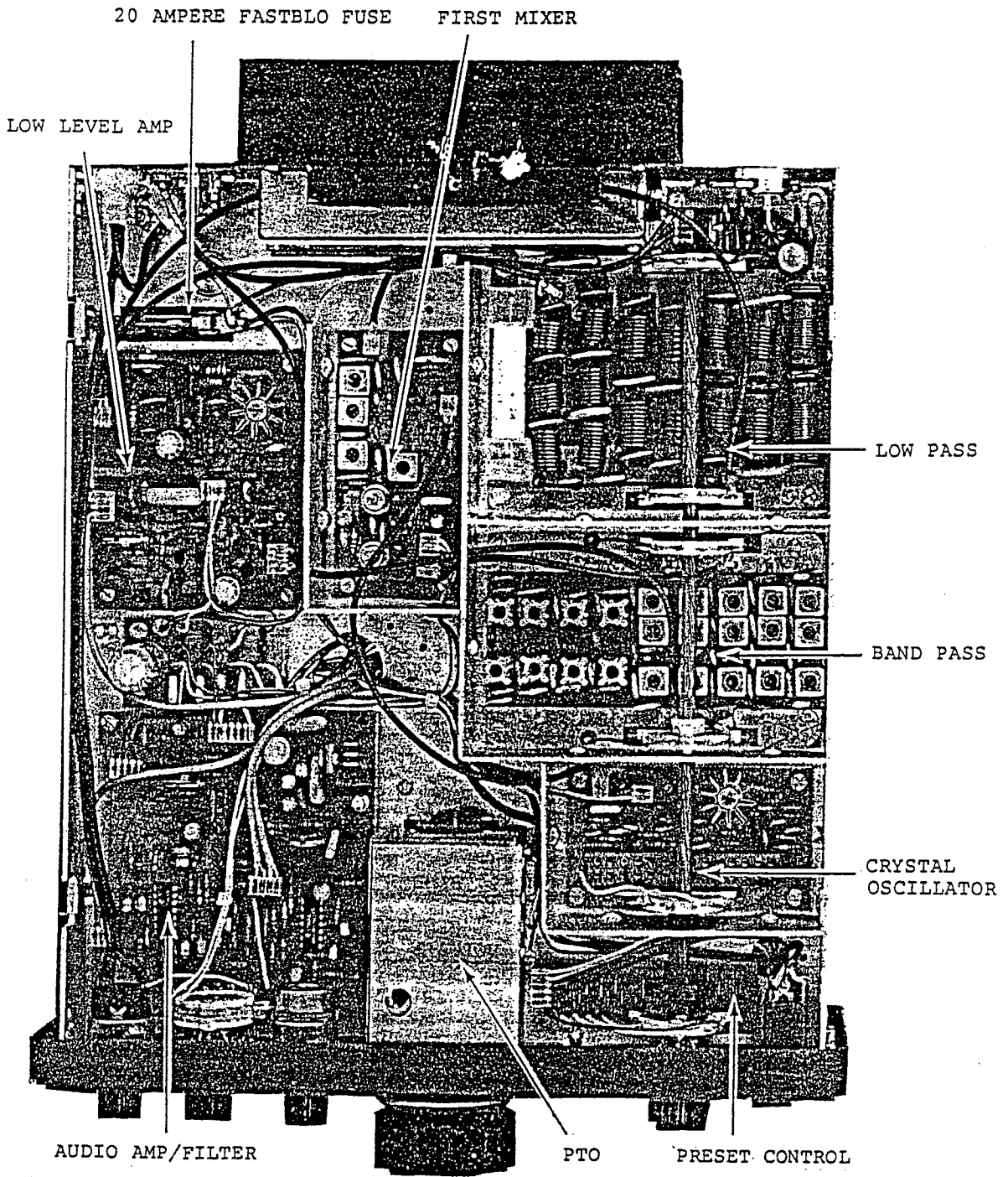

FIGURE 5-2 BOTTOM VIEW

TROUBLE ANALYSIS

Make certain all connectors are plugged in and firmly seated. A logical process of elimination in conjunction with a study of the main schematic diagram, block diagram and the table on trouble shooting will aid in isolating trouble. Table 5-1 lists typical audio output levels as measured at the speaker in receive mode. This will make troubleshooting the receiver section quite simple if the necessary test equipment is available. RF signal levels are also given for several points.

Table 5-1

Control Settings: AF GAIN - full cw, NOTCH - full cw, SELECTIVITY - SB-1, BAND - 14.0

TERMINAL NUMBER	RF FREQUENCY GENERATOR	GENERATOR VOLTAGE SETTING	AC VOLTMETER CONNECTED ACROSS SPEAKER
20	1000 Hz	30 mv	1 volt @ 8 ohms
16	1000 Hz	.3 mv	1 volt @ 8 ohms
35	6.3 MHz	210 uv	1 volt @ 8 ohms
12	6.3 MHz	.64 uv	1 volt @ 8 ohms
22	11.0-11.5 MHz	.28 uv	1 volt @ 8 ohms
28	14.0-14.5 MHz	.22 uv	1 volt @ 8 ohms
ANTENNA JACK	14.0-14.5 MHz	.38 uv	1 volt @ 8 ohms

TERMINAL NUMBER	BAND	RF VOLTMETER (RMS)
9 (VFO)	N.A.	.3 volt
29 (Crystal Oscillator)	1.8 3.5 7.0 10.0 14.0 21.0 28.0 28.5 29.0 29.5	1.0 volt 1.0 volt .9 volt 2.5 volt 2.5 volt 1.9 volt 1.5 volt 1.4 volt 1.4 volt 1.3 volt
15 (6.3 MHz)	N.A.	.74 volt

N.A. - not applicable

VOLTAGE MEASUREMENTS

Voltage readings are given for each of the printed circuit board sub-assemblies. Refer to the individual circuit sub-assembly. It is recommended that a VTVM be used for these measurements. A VOM may be used if it has an input impedance of not less than 20,000 ohms-per-volt. Voltage measurements with a VOM will yield lower readings in high impedance circuits. Do not use a VOM for RF measurements.

SIGNAL TRACING

Appropriate test points and normal signal levels are listed in table 5-1. The values listed are nominal. Signal levels in a given transceiver may differ from those listed by a factor of 20 percent without noticeable variation in performance. Signal levels will be given for the receiver. A signal generator with accurately calibrated output must be used to provide the RF signal sources voltages indicated. Measurement of oscillator injection voltages require the use of an RF VTVM.

RECEIVER ALIGNMENT

All tuned circuits are used in both transmit and receive modes. Once they are aligned for the receive mode they do not need any further adjustment in transmit.

BANDPASS FILTER ALIGNMENT

Set the transceiver with the bottom up. Locate the bandpass filter board with the aid of figure 5-2. Connect an external speaker or 8 ohm resistive load to the phone jack. Connect an AC VTVM to the load. Connect an RF signal generator to the antenna jack. Switch to the 1.8 MHz band. Locate TP1 on bandpass filter photograph and temporarily connect a 150 ohm resistor from TP1 to ground. Set the generator to 1.9 MHz and tune the transceiver until the signal is peaked on the AC VTVM. Reduce the generator output below AGC threshold as indicated by no movement of the "S" meter. Tune the input coil and output coil for maximum reading on the meter. Remove the 150 ohm resistor, reduce the generator output as above and tune the center coil for maximum reading. This completes alignment of the 1.8 MHz bandpass filter. Using the same procedure and the following frequencies, align the first five bands.

TEST POINT	INPUT COIL	CENTER COIL	OUTPUT COIL	BAND	FREQUENCY
TP1	L1	L2	L3	1.8	1.9 MHz
TP2	L4	L5	L6	3.5	3.75 MHz
TP3	L7	L8	L9	7.0	7.15 MHz
TP4	L10	L11	L12	10.0	10.15 MHz
TP5	L13	L14	L15	14.0	14.250 MHz
	L16		L17	18.0	18.250 MHz
	L18		L19	21.0	21.250 MHz
TP6, TP7	L20		L21	24.5	24.250 MHz
TP8, TP9	L22		L23	28.0	29.0 MHz

NOTE: Alignment of the 18 MHz and 24 MHz bands are not possible unless the appropriate crystals are installed.

18 MHz

Switch the transceiver to 18 MHz. Set signal generator to 18.250 and peak the output on the AC VTVM. Reduce generator output as before. Tune input and output coil for maximum reading on the AC VTVM.

21 MHz

Switch the transceiver to 21.0 MHz, set the signal generator to 21.250 MHz and proceed as for 18 MHz.

24.0 MHz

Switch the transceiver to 24.0 MHz. Set the signal generator to 24.250 MHz. Temporarily connect a 150 ohm resistor to TP6, peak the output and reduce the generator output as before. Tune the output coil for maximum reading on the AC VTVM. Connect the 150 ohm resistor to TP7 and tune the input coil for maximum reading on the VTVM.

28.0 MHz

Switch the transceiver to 28.0 MHz and set the signal generator to 29.0 MHz. Temporarily connect a 150 ohm resistor to TP8, peak the output on the AC VTVM and reduce the generator output as before. Tune the output coil for maximum indication on the AC VTVM. Remove the resistor from TP8 and connect to TP9. Tune the input coil for maximum reading on the AC VTVM. This completes alignment of the bandpass filter for both transmit and receive.

FIRST MIXER

Alignment of 11.0 to 11.5 MHz circuits: Switch transceiver to 14.0 MHz band and set signal generator to 14.250 MHz. Peak the output on the AC VTVM. Temporarily connect a 150 ohm resistor across L5 (junction of C15 and C13 and ground). Reduce the signal generator output below AGC threshold as indicated by no movement of the "S" meter. Tune the input coil L4 and output coil L6 for maximum indication on the meter. Remove the 150 ohm resistor, reduce the signal generator output as before and tune the center coil, L5, for maximum output on the AC VTVM. Tune coil L7 for maximum indication on the AC VTVM. NOTE: This adjustment is extremely broad. The peak may only be in the order of 1 dB. This completes alignment of the first mixer.

SECOND MIXER

Alignment of 6.3 MHz circuits. Switch transceiver to 14.0 Mhz band and set signal generator to 14.250 MHz. Peak the output on the AC VTVM. Reduce the signal generator output below AGC threshold as indicated by no movement of the S meter. Tune L2 for maximum indication on the AC VTVM. NOTE: This adjustment is extremely broad. The peak may only be in the order of 1 dB. This completes alignment of the second mixer.

"S" METER ADJUSTMENT

Set the transceiver bandswitch to 14.0 MHz and the signal generator to 14.250 MHz. Adjust tuning for maximum reading on the S meter. Set the signal generator output for 50 microvolts and adjust potentiometer R26 for a reading of S9.

BFO FREQUENCY ADJUSTMENT

Remove connector 8 and attach a frequency counter capable of reading to the nearest Hz. Note location of the ground and hot pin on the schematic for SSB board (80552) relative to the locking TAB. Switch to LSB and adjust C1 for a frequency of 6296.600 kHz. Switch to USB and adjust C2 for 6300.000 kHz. Switch to CW, set drive control full CCW and pull ALC control to lock position. Adjust C3 for 6299.250 kHz.

USB/LSB BALANCE

Switch the transceiver to 14.0 MHz. Set the mode switch to LSB and tune for a reading of 14.2500 on the dial. Switch to USB and adjust potentiometer R3 for a reading of 14.2500. This adjustment compensates for the BFO shift between USB/LSB and must be done after the above BFO adjustment has been made. NOTE: This is a constant percentage capacitance change in the VFO. This will result in an error in balance of approximately 100 Hz at the extreme band edges.

OFFSET TUNING ADJUSTMENT

Adjust the signal generator and transceiver tuning for a beat note of approximately 750 Hz. Center offset knob in the detent. Connect test point "TP" on control board to ground. Adjust potentiometer R19 for exactly the same tone.

TRANSMITTER ALIGNMENT

CARRIER BALANCE ADJUSTMENT

Connect a suitable dummy load to the antenna jack. Connect a high frequency oscilloscope across the dummy load. The oscilloscope must be capable of displaying the frequency of the transceiver. Set the transceiver to 7.0 MHz and set the drive control full CCW. Set the mode switch to LSB and place the transceiver in lock. Adjust carrier balance potentiometer R20 and trimmer C18 for minimum indication on the oscilloscope. These adjustments interact, so adjust first one then the other until neither produces any further decrease in the scope reading. Switch the mode to USB to see that the carrier is about the same for either sideband. If it is not, repeat above until carrier suppression is about equal for both sidebands.

SECOND-MIXER BALANCE

Connect a suitable dummy load to the antenna jack. Connect an oscilloscope capable of displaying 30.0 MHz across the dummy load. Set the bandwidth to 28.0 MHz and with the mode switch in LSB, place the transceiver in lock. Adjust mixer balance potentiometer R16 for minimum oscilloscope pattern.

SWR BRIDGE

Connect a suitable dummy load to the antenna jack. Switch the transceiver to 28.0 MHz. Set mode switch to CW. Place transceiver in lock and advance drive control for approximately 50 watts output. Adjust SWR null capacitor C2 for minimum indication on SWR meter. Check other bands for null. NOTE: 1.8 MHz band will not produce as low a null as the other bands. Set transceiver to 28.0 MHz. Connect a wattmeter between the transceiver and the dummy load. Parallel the dummy load with another dummy load or a resistor of sufficient power capability to handle 50 watts of RF power for a short period of time. Set output of transceiver for 90 watts and adjust potentiometer R3 for a 2 to 1 reading on the SWR meter. NOTE: SWR adjustments will affect the ALC setting, transmit gain, ALC & ALC light.

Connect a wattmeter and dummy load to the antenna jack. Set transmit i-f gain potentiometer R23 for maximum gain (set thumb pot towards the rear of the transceiver). Set the ALC control potentiometer R11 on the LOW LEVEL AMPLIFIER (80559) for no ALC. (Turn pot towards closest side of transceiver.) Set the transceiver to 7.0 MHz and the mode switch to CW. Place the transceiver in LOCK and carefully adjust drive for 100 watts on the wattmeter. NOTE: Without ALC it will be very easy to overdrive the transceiver resulting in excessive current being drawn from the power supply. With the i-f gain potentiometer R23 adjust the power output to 10 watts. (Reduction in i-f gain of 10 dB). Reset the power output to 100 watts with the drive control. Set the ALC potentiometer R11 on 80559 for 90 watts output. This will be the power output under ALC conditions. Check other bands. The output under ALC conditions should be between 85 and 100 watts.

Turn drive control full CCW. Adjust ALC light potentiometer R15 on 80559 until the ALC light is definitely out. This is not a critical adjustment but if the light is set at the point where it is just about to come on, it may stay on if the transceiver is used with slightly higher voltage power supplies.

PTO ALIGNMENT

The permeability tuned oscillator is housed in a sealed enclosure on the bottom of the main chassis. The main coil, L3, is shunted with L2 and has L1 in series. Adjustment of these two slug tuned coils, which are on the same coil form, determines the linearity and band edge points. L2 is the top slug. L1 is the bottom slug.

1. Place OFFSET knob in center detent. Connect a frequency counter with at least 100 mV sensitivity to the VFO OUT jack on the rear panel.
2. Power transceiver to receive mode.
3. Set main tuning shaft 40 kHz up from full counterclockwise position as indicated on readout.
4. Observe counter reading and if it is not 5.000 MHz, slightly touch up L2 slug. Slug position in the coil should be such that a clockwise rotation of the slug decreases frequency.
5. Run tuning knob up scale and note counter readings at each 100 kHz of increase. If readings are within ± 5 kHz, linearity may be improved, especially if frequency reading at 5.500 MHz is not exactly aligned, or if all deviations from the first setting are in the same direction.
6. If VFO range is compressed, i.e. reading on counter at what should be 5.5 MHz is less than this, reset tuning to 5.0 position, turn L2 slug a fraction of a turn clockwise and then compensate for this decrease in frequency by turning L1* slug also clockwise for a 5.0 MHz counter reading. Repeat step 5 to see if correction was sufficient or too much.
7. If range of VFO is expanded instead of compressed, compensation in the opposite direction is indicated. This is accomplished by turning slugs in opposite direction.

*NOTE: To reach L1 slug without upsetting position of L2 slug, use the tuning tool with reduced shank that is provided with DELTA. Also note that L2 is used to adjust spread of VFO range and L1 to bring frequency to correct value.

SEMICONDUCTOR PIN IDENTIFICATION

Pins viewed from top of PC board.

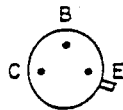

2N3866 2N5109

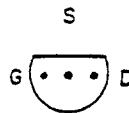

2N5486

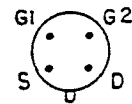

FET 40823

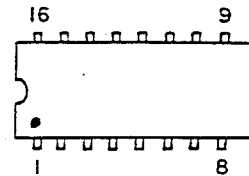

MC14528CP MC14050CP
MC14521CP



MPS U01

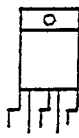

LM-383T

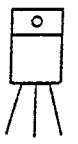

MRF 476



MJE 520

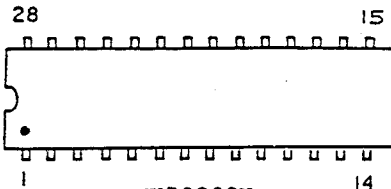

MK50398N

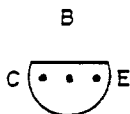

MPS 6514 MPS 3693
2N5087

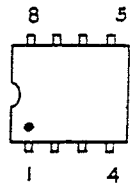

MC1350P RC1436N
RC4558P

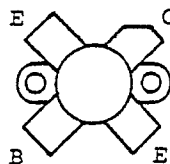

MRF 458



MC7805CP

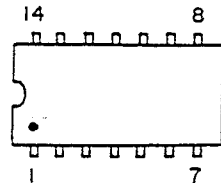

LM-3900N MC1723CL
75491APC 75492APC
25097 Programmed

PTO 80577

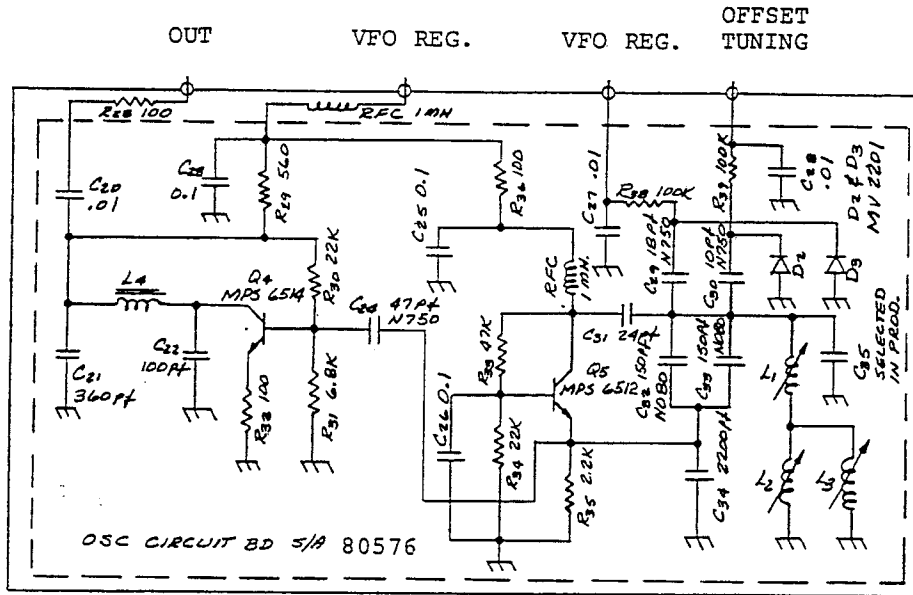

PTO 80577

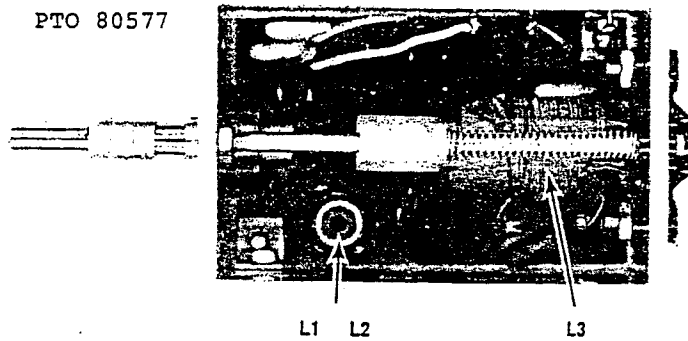

PARTS LIST			QTY.
	21007	CHOKE-RF, 1 MHY	2
C23,25,26	23006	CAP-FXD, 0.1MF, 250V, FILM, 20%	3
C31	23014	CAP-FXD, 22PF, 50V, 5%, NPO	1
C29	23091	CAP-FXD, 18PF, CER, N750, 500V	1
C32,33	23097	CAP-FXD, 150PF, CER, N080, 5%	2
C30	23098	CAP-FXD, 10PF, CER, N750, 5%	1
C20,27,28	23132	CAP-FXD, .01MF, 100V, CER, Z5V, LNG	3
C22	23139	CAP-FXD, 100PF, 100V, 5%, N750	1
C24	23143	CAP-FXD, 47PF, 100V 5%, N750	1
C21	23147	CAP-FXD, 360PF, 100V, 10%, N1000	1
C34	23164	CAP-FXD, 2200PF, 100V, 5%, NPO	1
Q5	25032	TRANSISTOR-MPS 3693	1
Q4	25054	TRANSISTOR-MPS 6514	1
	28018	DIODE-VARACTOR, MV2201	2
L1,2	85151	TRANSFORMER RF, 60T, #36	1
L3	80136	PTO COIL	1
L4	85152	TOROID-RF, 17T, #28	1

80563 CRYSTAL OSCILLATOR

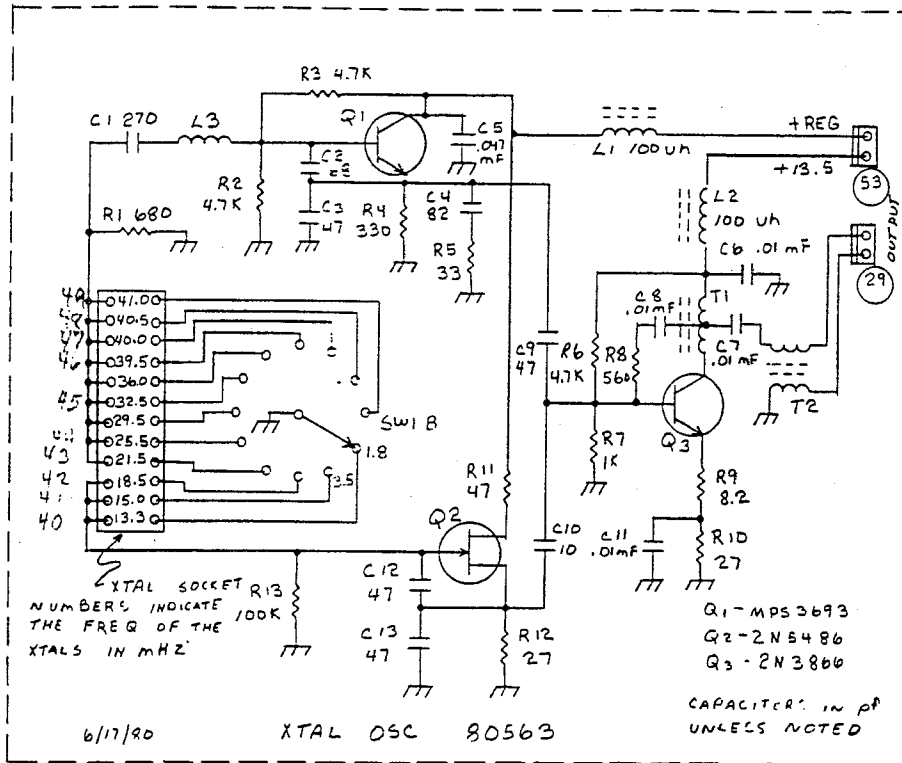

PARTS LIST

REF	QTY	DESCRIPTION	QTY
L1,2	21060	CHOKE-RF, 100UH, 100MA	2
C10	23044	CAP-FXD, 10PF, 1KV, CER, 5%	1
C5	23048	CAP-FXD, .047MF, 250V, FILM, 20%	1
C6-8,11	23132	CAP-FXD, .01MF, 100V, CER, Z5V	4
C4	23140	CAP-FXD, 82PF, 100V, 5%, N470	1
C3,9,12,13	23143	CAP-FXD, 47PF, 100PF, 100V, 5%, N750	4
C2	23194	CAP-FXD, 68PF, 5%, N1500, CERAMIC	1
C1	23201	CAP-FXD, 270PF, 5%, 100V, N1500	1
Q3	25027	TRANSISTOR-RF POWER, 2N3866	1
Q1	25032	TRANSISTOR-MPS3693	1
Q2	25060	TRANSISTOR-2N5486	1
	32025	SWITCH WAFER-ROTARY, PC MTG	1
	48040	XTAL 13.3MHZ .002% FUND HC-25/U	1
	48041	XTAL 15.0MHZ .002% FUND HC-25/U	1
	48042	XTAL 18.5MHZ .002% FUND HC-25/U	1
	48043	XTAL 21.5MHZ .002% 30T HC-25/U	1
	48044	XTAL 25.5MHZ .002% 30T HC-25/U	1
	48045	XTAL 32.5MHZ .001% 30T HC-25/U	1
	48046	XTAL 39.5MHZ .001% 30T HC-25/U	1
	48047	XTAL 40.0MHZ .001% 30T HC-25/U	1
	48048	XTAL 40.5MHZ .001% 30T HC-25/U	1
	48049	XTAL 41.0MHZ .001% 30T HC-25/U	1
T1	85120	TRANSFORMER-RF, BIFILAR NP	1
L3	85136	COIL-RF, 15T #28	1
T2	85149	TRANSFORMER-RF 1:1 BALUN NP	1

80563 CRYSTAL OSCILLATOR

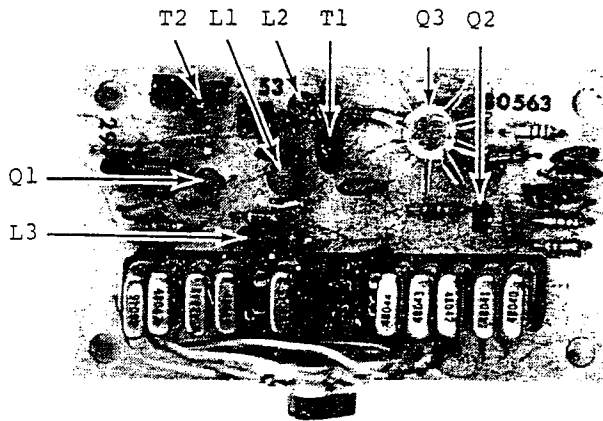

TRANSISTOR	COIL	BASE	EMITTER
	Receive	Receive	Receive
Q1	8.1	3.76	3.61
Q2	8.0	0	3.75
Q3	13.0	1.95	1.23

NOTE - Readings same in transmit. Q1 and Q2 are measured in oscillating condition. Q1 on 10.0 MHz. Q2 on 1.8 MHz.

80560 1ST MIXER

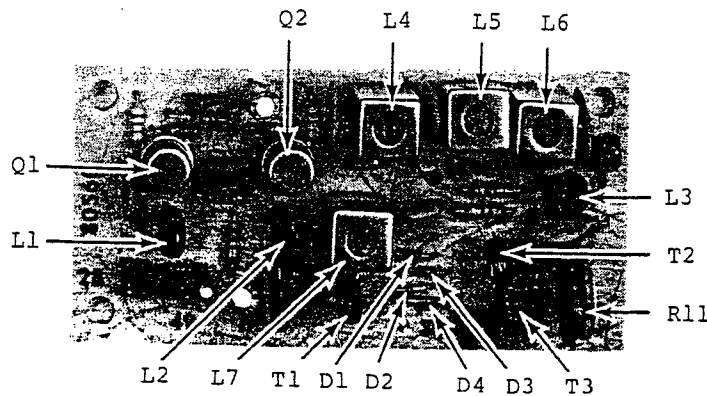
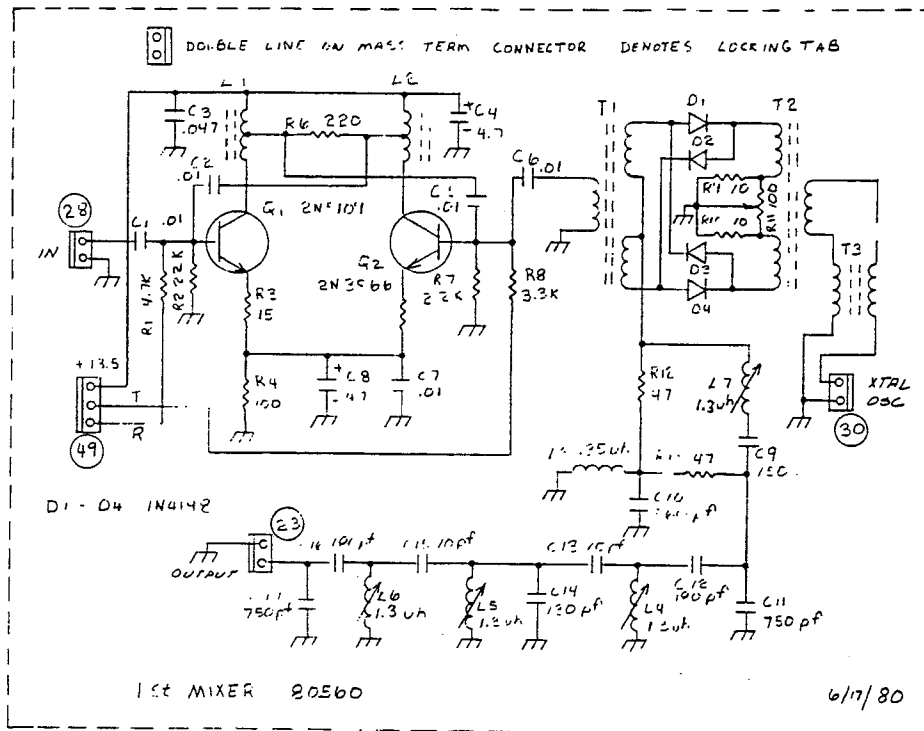

1ST-MIXER 80560

PARTS LIST

QTY	Part No.	Description	QTY
4	L4-7	COIL-SHIELDED 1.3UH	4
1	C3	CAP-FXD, .047MF, 250V, FILM, 20%	1
2	C13,15	CAP-FXD, 10PF, CER, N750, 5%	2
5	C1,2,5-7	CAP-FXD, .01MF, 100V, CER, 25V	5
1	C10	CAP-FXD, 560PF, 100V, 5%, N1000	1
2	C12,16	CAP-FXD, 180PF, 100V, 5%, N750	2
1	C9	CAP-FXD, 150PF, 100V, 10%, N750	1
2	C11,17	CAP-FXD, 750PF, 100V, 10%, N1500	2
1	C14	CAP-FXD, 130PF, 500V, 5%, N1500	1
2	C4,8	CAP-FXD, 4.7MF, 25V, EL, VERT	2
1	Q2	TRANSISTOR-RF POWER, 2N3866	1
1	Q1	TRANSISTOR-2N5109	1
4	D1-4	DIODE-1N4148/1N914, SIL	4
1	R11	RES-VAR, 100, LIN, PC VERT, 30%	1
2	L1,2	TRANSFORMER-RF, BIFILAR NP	2
2	T1,2	RF TRANSFORMER-TRIFILAR NP	2
1	L3	TOROID COIL, 6T #28	1
1	T3	TRANSFORMER-RF 1:1 BALUN NP	1

TRANSISTOR	COIL		BASE		EMITTER	
	Receive	Transmit	Receive	Transmit	Receive	Transmit
Q1	13	13	3.31	0	2.63	2.36
Q2	13	13	0	3.44	2.29	2.71

80553 2ND MIXER

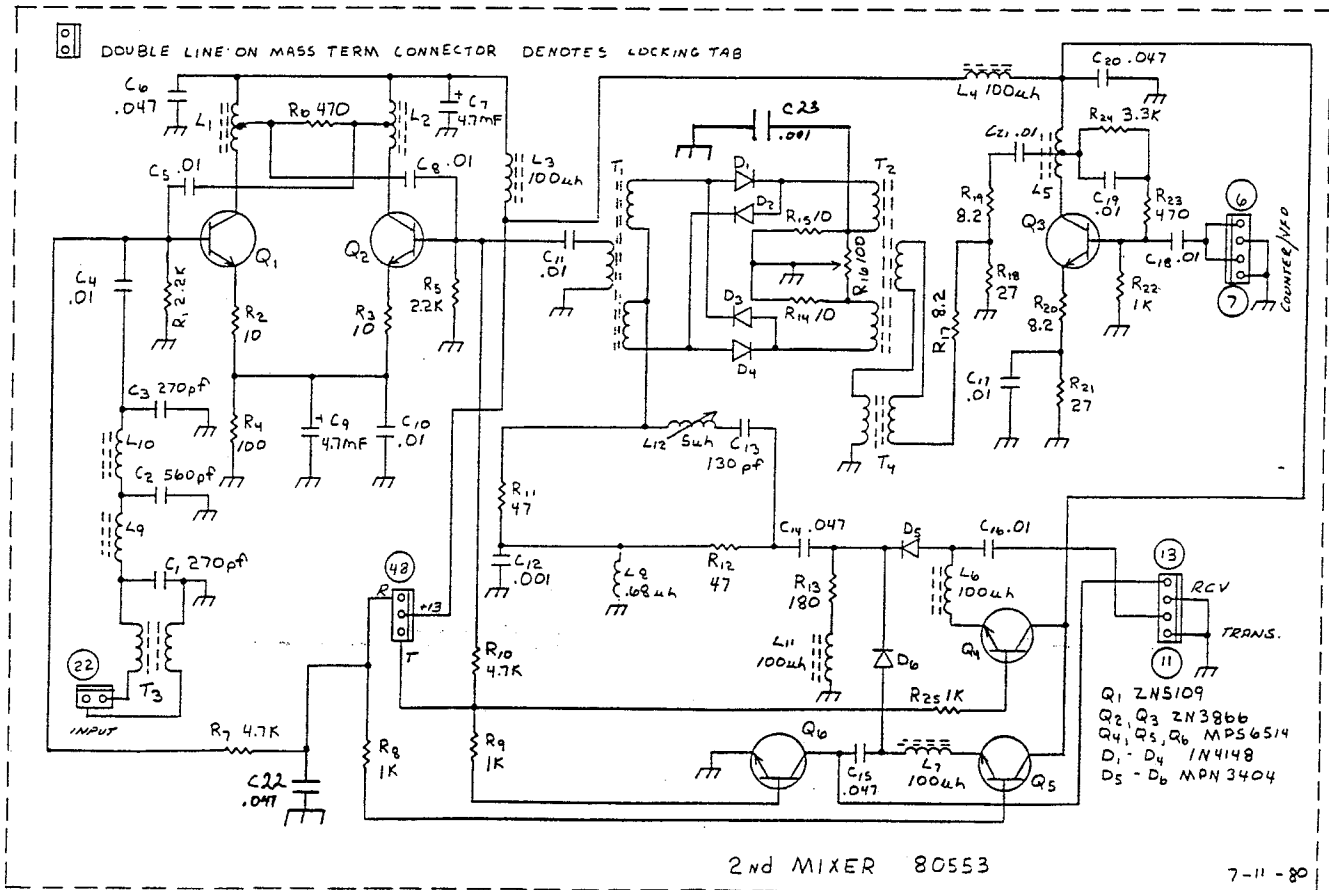

SECOND MIXER 80553

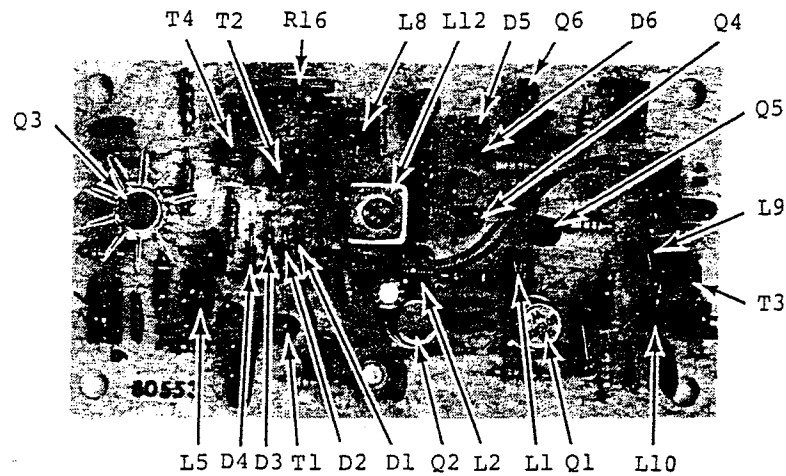

PARTS LIST

			QTY
L12	21056	COIL-SHIELDED 5.8UH	1
L3,4,6,7,11	21060	CHOKE-RF, 100UH, 100MA	5
C6,14,15,20,22	23048	CAP-FXD, .047MF, 250V, FILM, 20%	5
C4,5,8,10,11,16-19,21	23132	CAP-FXD, .01MF, 100V, CER, Z5V	10
C12,23	23133	CAP-FXD, .001MF, 500V, CER, 5%, Z5F	2
C2	23135	CAP-FXD, 560PF, 100V, 5%, N1000	1
C13	23155	CAP-FXD, 130PF, 500V, 5%, N1500	1
C7,9	23188	CAP-FXD, 4.7MF, 25V, EL, VERT.	2
C1,3	23201	CAP-FXD, 270PF, 5%, 100V, N1500	2
Q2,3	25027	TRANSISTOR-RF POWER, 2N3866	2
Q4-6	25054	TRANSISTOR-MPS6514	3
Q1	25079	TRANSISTOR-2N5109	1
D1-4	28001	DIODE-1N4148/1N914, SIL	4
D5,6	28017	DIODE-PIN, MPN3404	2
R16	30071	RES-VAR, 100, LIN, PC VERT, 30%	1
L8	85091	TOROID-RF, 9T, #28	1
L1,2,5	85120	TRANSFORMER-RF, BIFILAR NP	3
T1,2	85134	RF TRANSFORMER-TRIFILAR NP	2
L9,10	85148	TOROID COIL, 10T, #28	2
T3,4	85149	TRANSFORMER-RF 1:1 BALUN NP	2

TRANSISTOR	COLLECTOR		BASE		EMITTER	
	Receive	Transmit	Receive	Transmit	Receive	Transmit
Q1	13.0	13.0	3.34	0	2.70	1.7
Q2	13.0	13.0	0	2.64	2.43	1.9
Q3	13.0	13.0	2.38	2.38	1.68	1.68
Q4	13.0	13.0	0	9.48	0	8.76
Q5	13.0	13.0	11.16	0	10.43	0
Q6	0	0	0	.81	0	0

80554 I-F AMPLIFIER

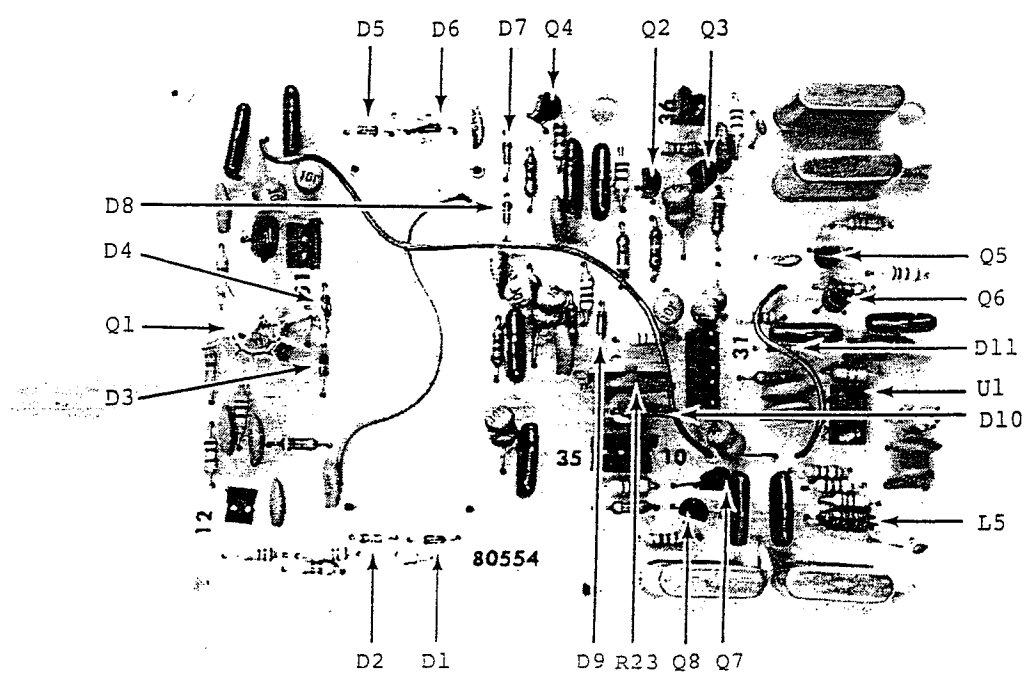
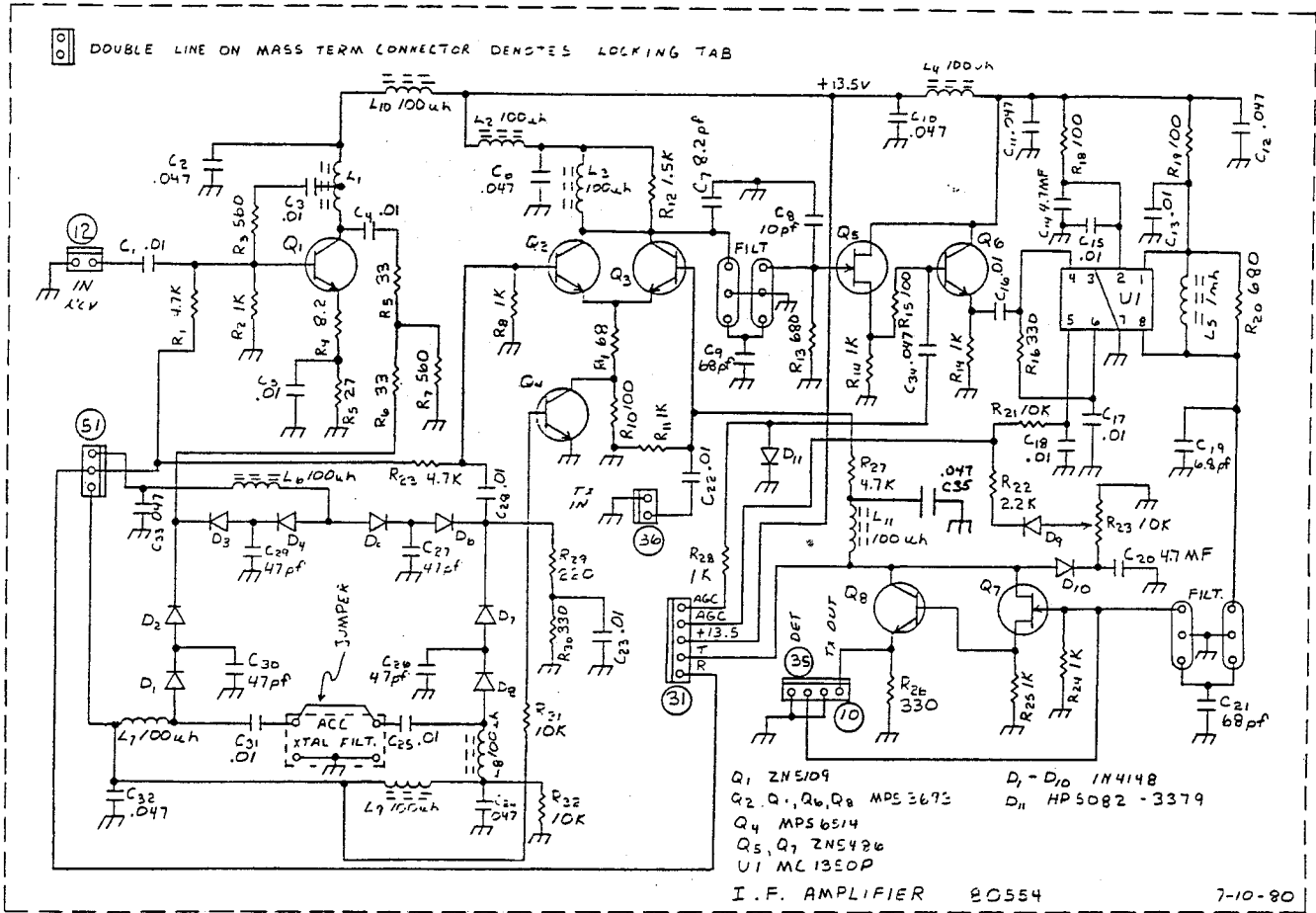

80554 I-F AMPLIFIER

PARTS LIST

			QTY
L5	21007	CHOKERF, 1MHY	1
L2-4,6-11	21060	CHOKERF, 100UH, 100MA	9
C2,6,10-12,24,32-35	23048	CAP-FXD, .047MF, 250V, FILM, 20%	10
C19	23112	CAP-FXD, 6.8PF, CER, N750	1
C7	23116	CAP-FXD, 8.2PF, CER, N750	1
C1,3-5,13,15-18,22,23,25,28,31	23132	CAP-FXD, .01MF, 100V, CER, Z5V	14
C26,27,29,30	23143	CAP-FXD, 47PF, 100V, 5%, N750	4
C8	23145	CAP-FXD, 10PF, 100V, 10%, NPO	1
C14,20	23188	CAP-FXD, 4.7MF, 25V, EL, VERT	2
C9,21	23194	CAP-FXD, 68PF, 5%, N1500 CERAMIC	2
Q2,3,6,8	25032	TRANSISTOR-MPS3693	4
Q4	25054	TRANSISTOR-MPS6514	1
Q5,7	25060	TRANSISTOR-2N5486	2
U1	25062	IC-MCL350P	1
Q1	25079	TRANSISTOR-2N5109	1
D1-10	28001	DIODE-1N4148/1N914, SIL	10
D11	28020	DIODE-PIN	1
R23	30038	RES-VAR, 10K, LIN, PC MOUNT	1
	48052	FLTR-XTAL, 4 POLE, 6.3MHZ X 2.4K	2
L1	85120	TRANSFORMER-RF, BIFILAR NP	1

TRANSISTOR	COIL (Drain)		BASE (Gate)		EMITTER (Source)	
	Receive	Transmit	Receive	Transmit	Receive	Transmit
Q1	13.0	13.0	1.74	0	1.05	0
Q2	13.0	13.0	2.01	0	1.33	.98
Q3	13.0	13.0	0	1.62	1.33	.98
Q4	.79	.58	0	0	0	0
Q5	13.0		0		2.15	
Q6	13.0		2.14		1.47	
Q7	0	9.73	0	0	0	2.00
Q8	0	9.73	0	2	0	1.31

U1	PIN	VOLTAGE
	1	12.77
	2	12.15
	3	0
	4	3.99
	5	5.67
	6	3.99
	7	0
	8	12.73

80552 SSB GENERATOR

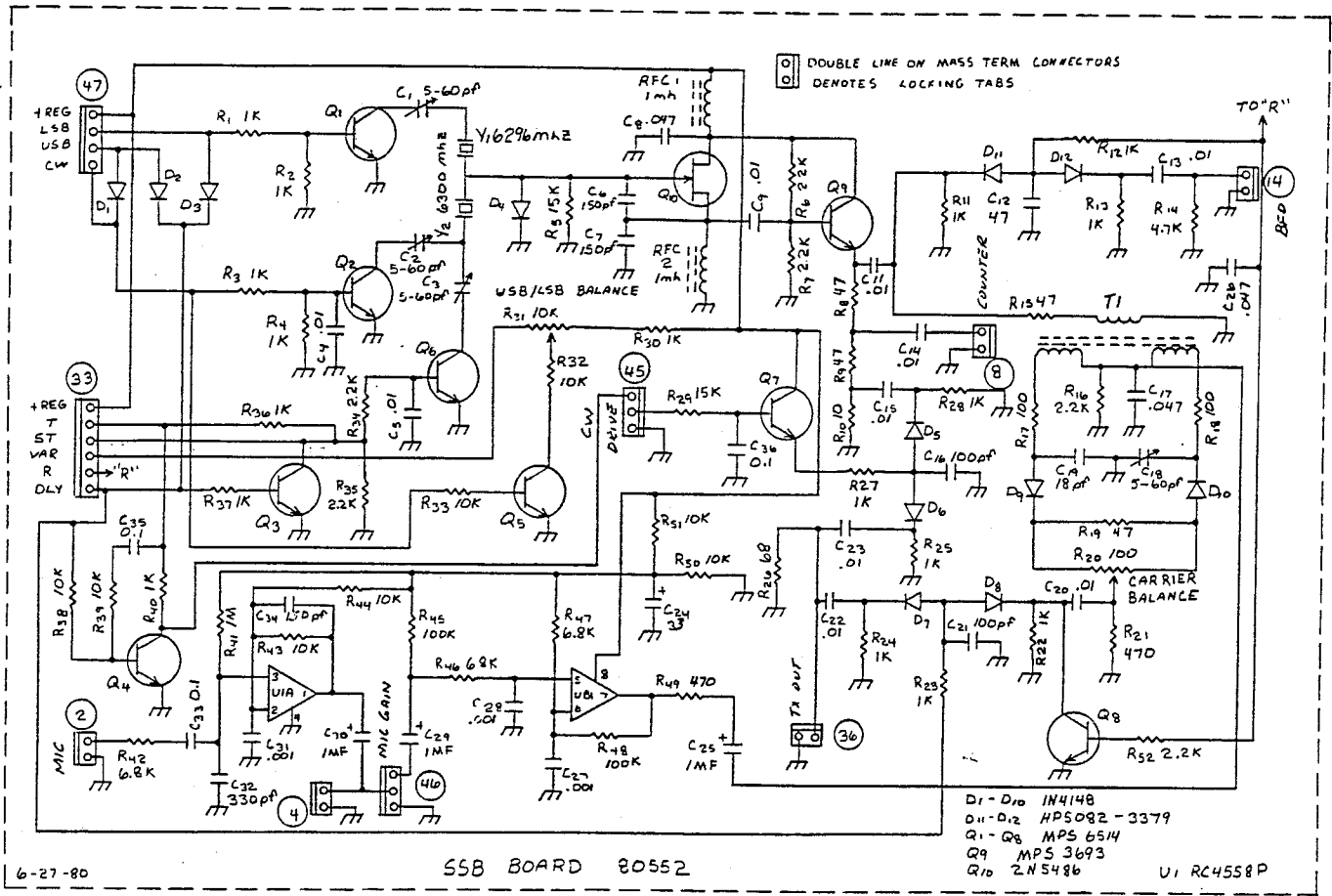

U1	PIN	VOLTAGE
	1	4.41
	2	4.30
	3	3.75
	4	0
	5	4.15
	6	4.21
	7	4.36
	8	8.30

U1 Q4 D8 D7 Q7 D10 R20 CARRIER BALANCE
 R31 USB/LSB BALANCE

80552 SSB GENERATOR

PARTS LIST		QTY
RF1,2	21007	2
C33,35,36	23006	3
C8,17,26	23048	3
C1,2,3,18	23061	4
C19	23091	1
C4,5,9,11,13,14,15,20,22,23	23132	10
C27,28,31	23133	3
C32	23136	1
C16,21	23139	2
C12	23143	1
C6,7,34	23146	3
C25,29,30	23181	3
C24	23182	1
Q9	25032	1
Q1-8	25054	8
Q10	25060	1
U1	25078	1
D1-10	28001	10
D11-12	28020	2
R31	30038	1
R20	30071	1
Y1	48050	1
Y2	48051	1
T1	85134	1

TRANSISTOR	COLLECTOR		BASE		EMITTER	
	Receive	Transmit	Receive	Transmit	Receive	Transmit
Q1	0		0		0	
Q2	0		.8		0	
Q3	0		.8		0	
Q4	0		.7		0	
Q5	0		.69		0	
Q6	0		0		0	
Q7	8.30		0		0	
Q8	.2	2.33	.7		0	
Q9	7.77		3.5		2.81	
Q10	1.77		2.33		0	

80555 DETECTOR/AGC

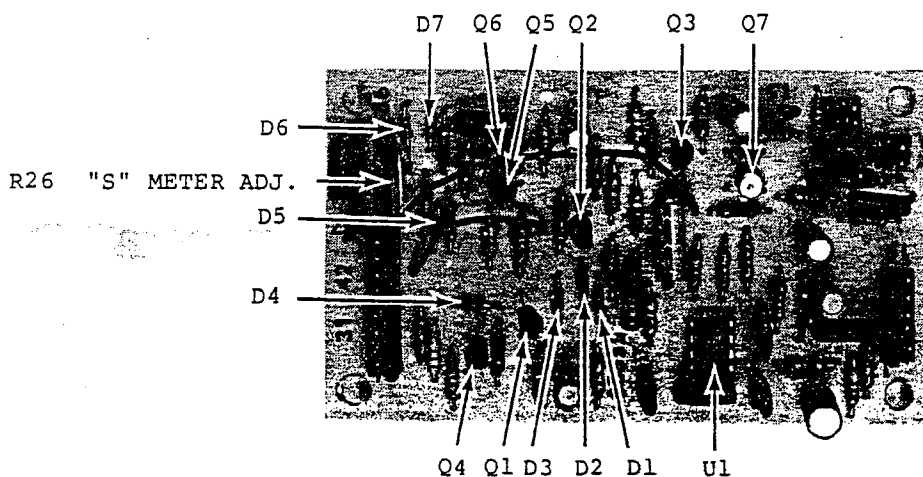

80555 DETECTOR/AGC

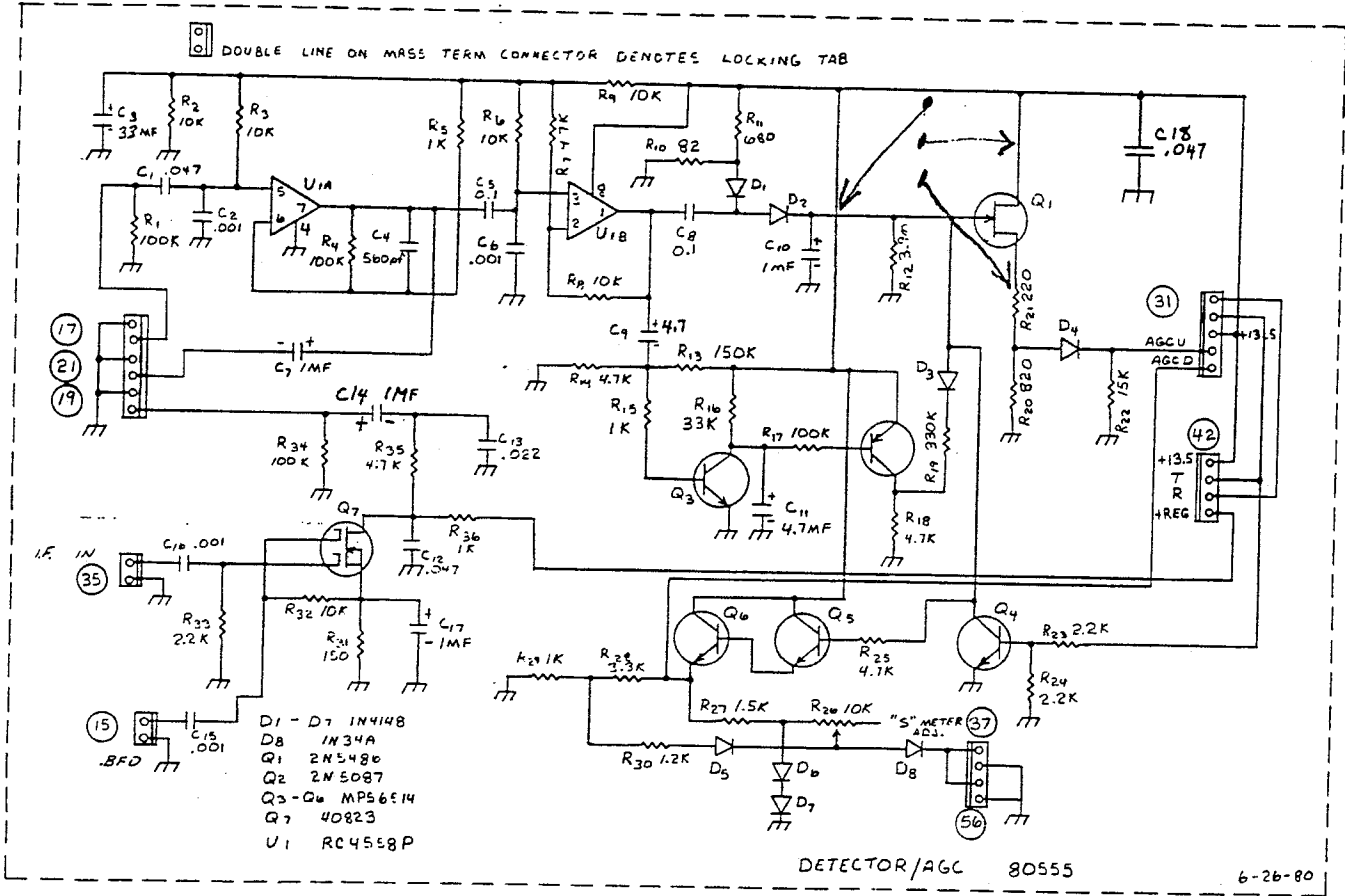

PARTS LIST

REF	QTY	DESCRIPTION
C13	23002	CAP-FXD, .022MF, 250V, FILM, 20%
C5,8	23006	CAP-FXD, 0.1MF, 250V, FILM, 20%
C9	23021	CAP-FXD, 4.7MF, 25V, EL
C1,12,18	23048	CAP-FXD, .047MF, 250V, FILM, 20%
C2,6,15,16	23133	CAP-FXD, .001MF, 500V, CER, 5%, Z5F
C4	23135	CAP-FXD, 560PF, 100V, 5%, N1000
C7,10,14,17	23181	CAP-FXD, 1MF, 50V, EL, VERT
C3	23182	CAP-FXD, 33MF, 16V, EL, VERT
C11	23188	CAP-FXD, 4.7MF, 25V, EL, VERT
Q2	25001	TRANSISTOR-2N5087
Q7	25022	TRANSISTOR-FET, 40823
Q3-6	25054	TRANSISTOR-MPS6514
Q1	25060	TRANSISTOR-2N5486
U1	25078	IC-RC4558P
D1-7	28001	DIODE-1N4148/1N914, SIL
D8	28031	DIODE-1N34, GE
R26	30038	RES-VAR, 10K, LIN, PC MOUNT

PIN	VOLTAGE
1	6.66
2	6.59
3	6.57
4	0
5	6.55
6	6.59
7	6.86
8	13.0

TRANSISTOR	SOURCE	DRAIN	GATE
Q1	.9	13.0	3.65

TRANSISTOR	COLLECTOR	BASE	EMITTER
Q2	13.0	13.0	0
Q3	13.0	.41	0
Q4	.9/0	0/.78	0/0
Q5	13.0	.9	.5
Q6	13.0	.5	0

TRANSISTOR	SOURCE	DRAIN	GATE 1	GATE 2
Q7	.24	6.67	0	.25

80558 AUDIO AMP/FILTER

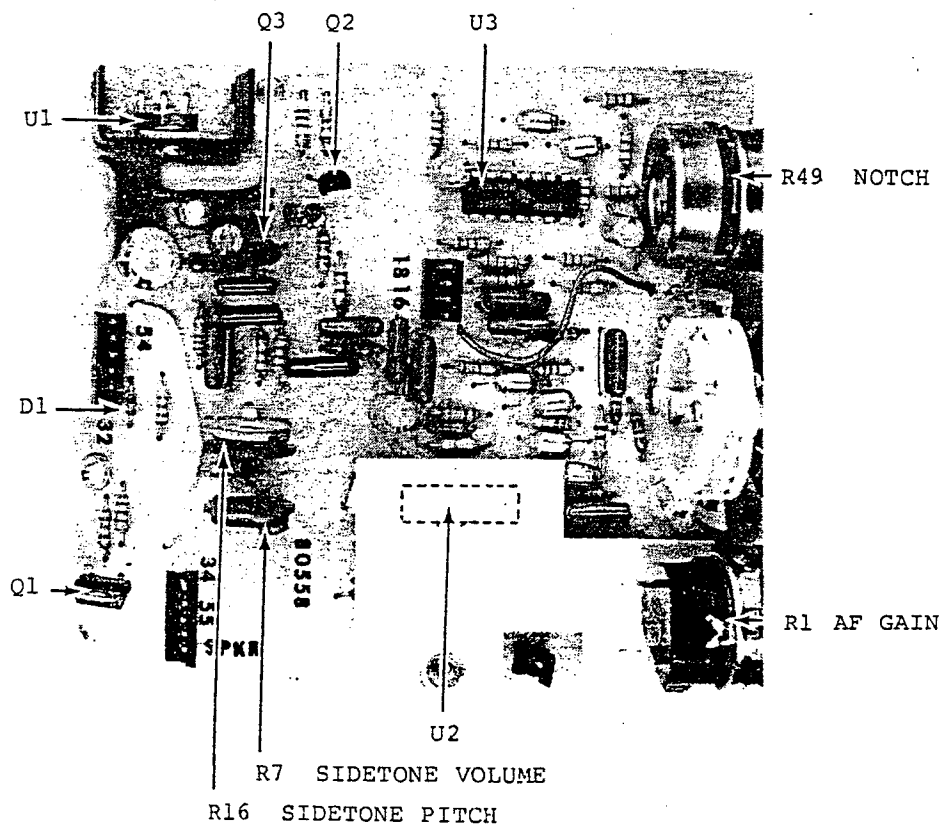
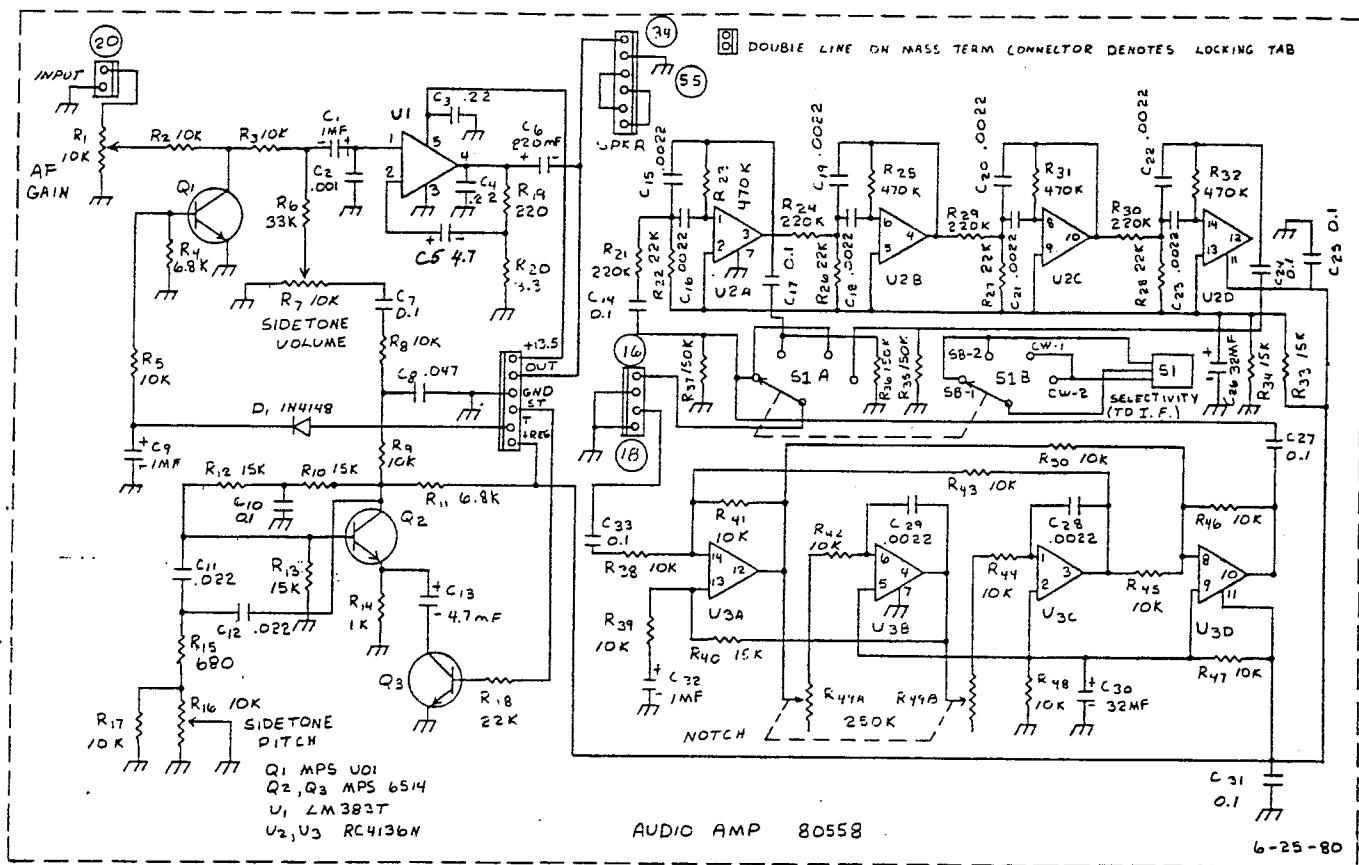

PARTS LIST

				QTY
C11,12	23002	CAP-FXD, .022MF, 250V, FILM, 20%		2
C7,10,14,17,23,24,27,31,33	23006	CAP-FXD, 0.1MF, 250V, FILM, 20%		9
C3,4	23012	CAP-FXD, 0.22MF, 250V, FILM, 20%		2
C8	23048	CAP-FXD, .047MF, 250V, FILM, 20%		1
C15,16,18-23,28,29	23070	CAP-FXD, 2200PF, 25V, FILM, 5%		10
C2	23133	CAP-FXD, .001MF, 500V, CER, 5%, Z5F		1
C1,9,32	23181	CAP-FXD, 1MF, 50V, EL, VERT		3
C26,30	23182	CAP-FXD, 33MF, 16V, EL, VERT		2
C5,13	23188	CAP-FXD, 4.7MF, 25V, EL, VERT		2
C6	23202	CAP-FXD, 220MF, 16V, EL, VERT		1
Q1	25053	TRANSISTOR-MPSU01		1
Q2,3	25054	TRANSISTOR-MPS6514		2
U2,3	25077	IC-RC4136N		2
U1	25099	IC LM-383T 25V		1
DI	28001	DIODE-1N4148/1N914, SIL		1
R7,16	30038	RES-VAR, 10K, LIN, PC MOUNT		2
R1	30211	RES-VAR, 10K, BD TAPER, SPST, PC		1
R49	30212	RES-VAR, DUAL 250K, REV LOG		1
	32010	SWITCH WAFER-SOLDER LUGS		1

TRANSMIT	COIL		BASE		EMITTER	
	Receive	Transmit	Receive	Transmit	Receive	Transmit
Q1	0	0	0	.65	0	0
Q2	3.75	3.75	1.22	1.22	.59	.59
Q3	.56	.56	0	0	0	0

U1

PIN	VOLTAGE
1	.6
2	.57
3	0
4	6.79
5	13.0

U2

PIN	VOLTAGE
1	4.16
2	4.16
3	4.16
4	4.16
5	4.16
6	4.16
7	0
8	4.16
9	4.16
10	4.16
11	8.30
12	4.16
13	4.16
14	4.16

U3

PIN	VOLTAGE
1	4.14
2	4.14
3	4.14
4	4.14
5	4.14
6	4.14
7	0
8	4.14
9	4.14
10	4.14
11	6.30
12	4.14
13	4.14
14	4.14

80557 CONTROL

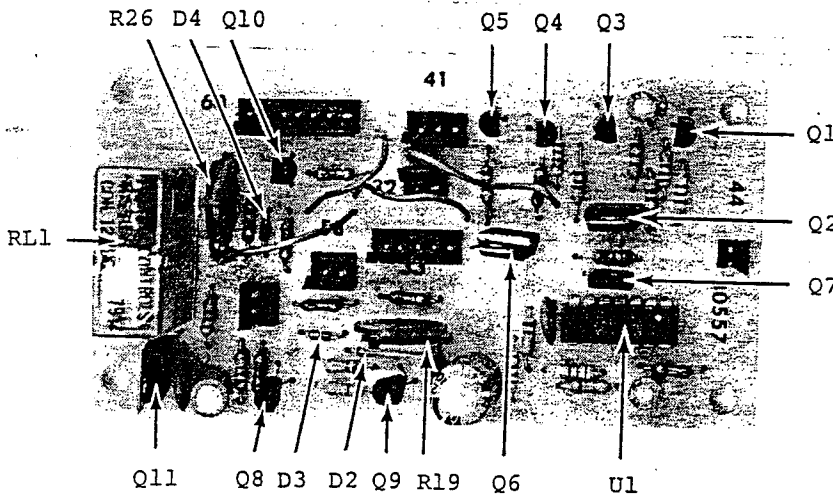
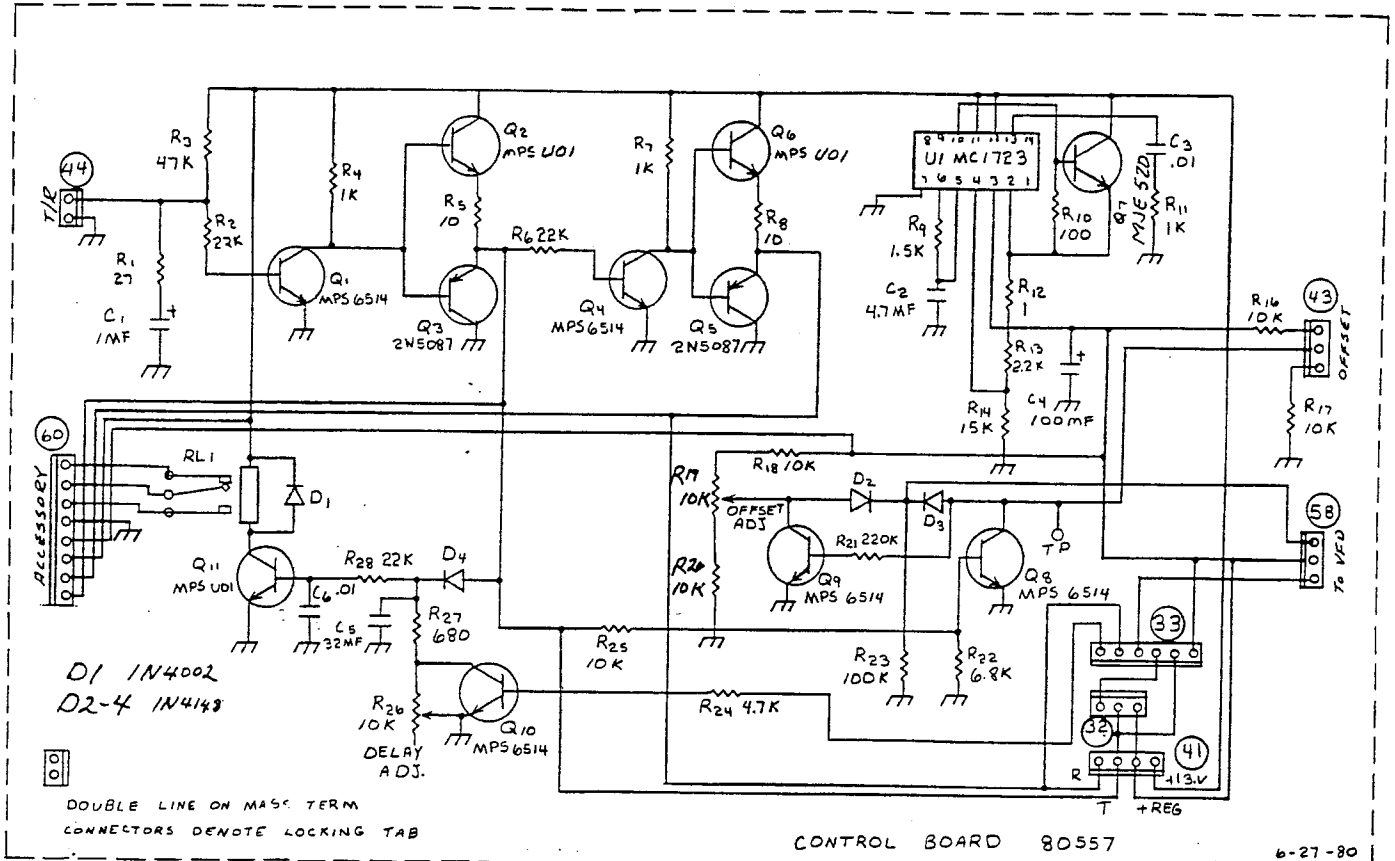

IC-1

PIN	RECEIVE	TRANSMIT
1	0	0
2	8.4	8.4
3	8.3	8.3
4	7.24	7.24
5	7.24	7.24
6	7.24	7.24
7	0	0
8	.28	.28
9	2.5	2.5
10	8.96	8.96
11	13.0	13.0
12	13.0	13.0
13	10.18	10.18
14	0	0

PARTS LIST

REF	QTY	DESCRIPTION
C3,6	23132	CAP-FXD, .01MF, 100V, CER, Z5V
C1	23181	CAP-FXD, 1MF, 50V, EL, VERT
C5	23182	CAP-FXD, 33MF, 16V, EL, VERT
C2	23188	CAP-FXD, 4.7MF, 25V, EL, VERT
C4	23189	CAP-FXD, 100MF, 25V, EL, VERT
Q3,5	25001	TRANSISTOR-2N5087
Q7	25002	TRANSISTOR-POWER, MJE520
U1	25050	TRANSISTOR-MC1723CL
Q2,6,11	25053	TRANSISTOR-MPSU01
Q1,4,8-10	25054	TRANSISTOR-MPS6514
D1	28000	DIODE-POWER, 1N4002, SIL
D2-4	28001	DIODE-1N4148/1N914, SIL
R19,26	30038	RES-VAR, 10K, LIN, PC MOUNT
RL1	32034	RELAY SPDT, 12VDC

QTY

CONTROL BOARD 80557

TRAN-SISTOR	COLLECTOR		BASE		EMITTER	
	Receive	Transmit	Receive	Transmit	Receive	Transmit
Q1	.13	12.25	.72	0	0	0
Q2	13.0	13.0	.13	12.25	0	11.52
Q3	0	0	.13	12.25	0	9.73
Q4	12.94	0	0	.73	0	0
Q5	0	0	12.94	0	11.47	0
Q6	13.0	13.0	12.94	0	12.26	0
Q7	13.0	13.0	8.96	8.96	8.4	8.4
Q8	3.82	0	0	.71	0	0
Q9	.12	3.82	.64	0	0	0
Q10	0-SSB/0-CW	0-SSB/8.3CW	.73SSB/0-CW	.76SSB/0-CW	0-SSB/0-CW	0-SSB/0-CW
Q11	13.0	.12	.7	0	0	0

80562 BAND PASS FILTER

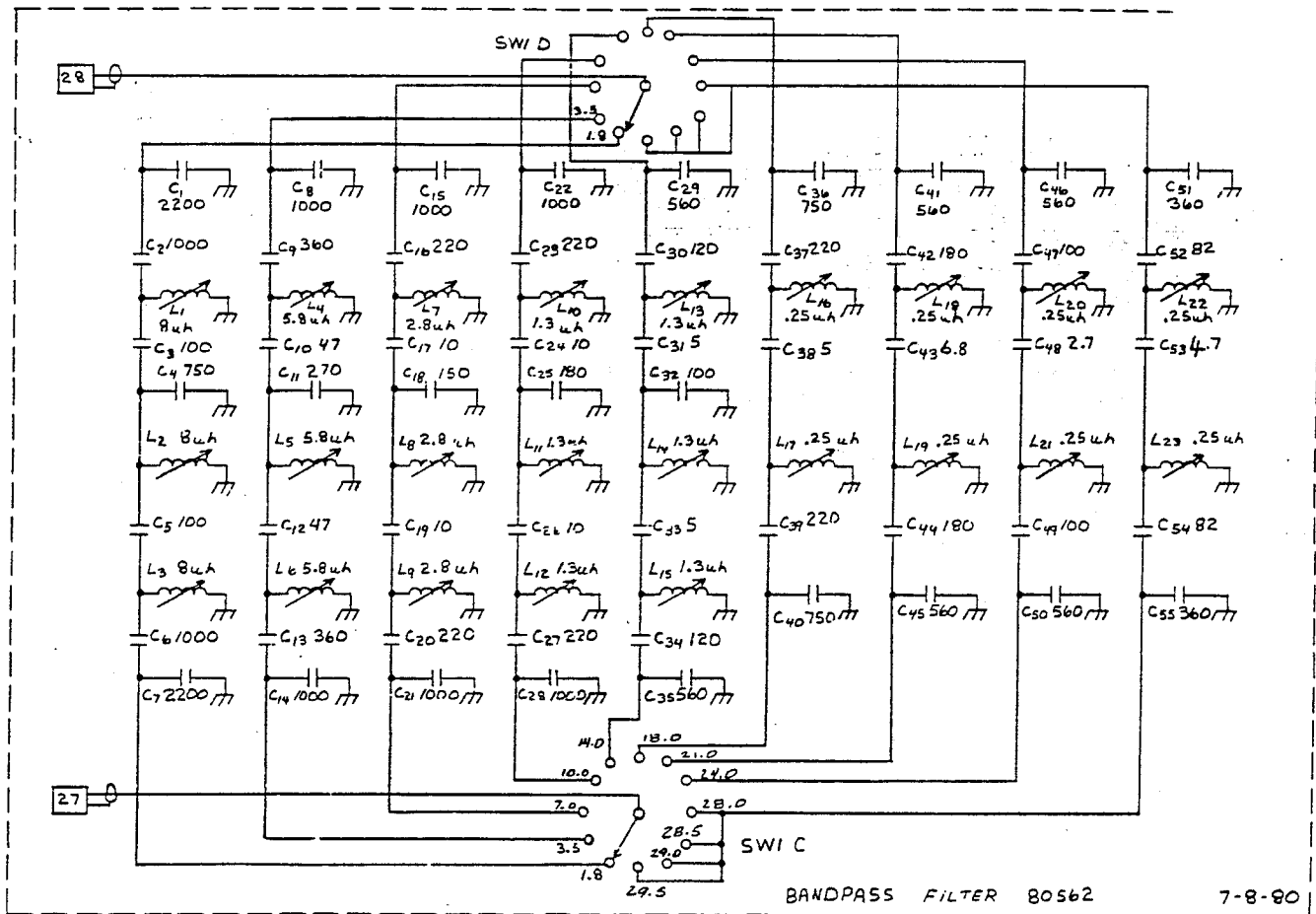

BANDPASS FILTER 80562

7-8-80

80562 BAND PASS FILTER

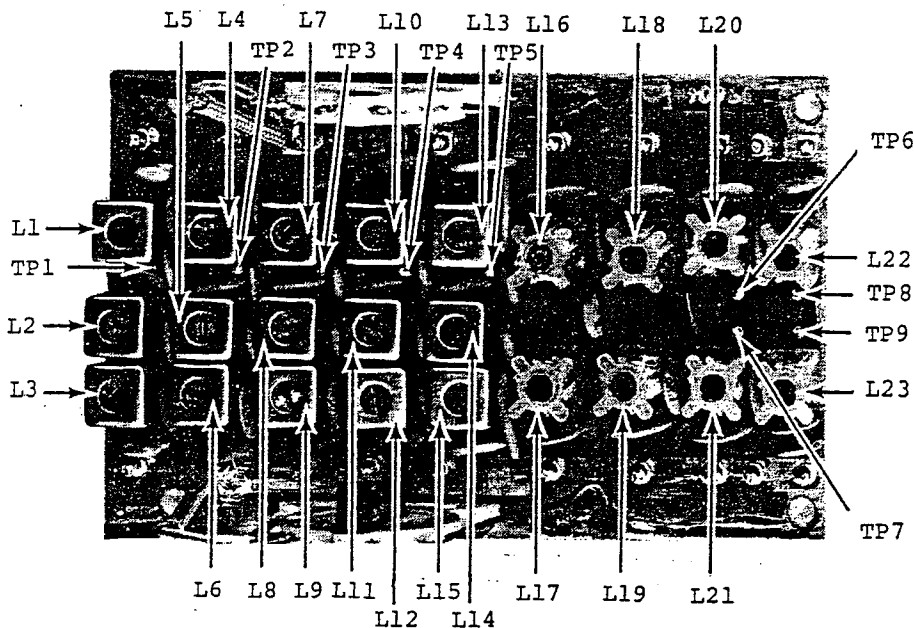

PARTS LIST			QTY
L1-3	21055	COIL-SHIELDED 8UH	3
L4-6	21056	COIL-SHIELDED 5.8UH	3
L7-9	21057	COIL-SHIELDED 2.8UH	3
L10-15	21058	COIL-SHIELDED 1.3UH	6
L16-23	21059	COIL-UNSHIELDED .25UH	8
C53	23047	CAP-FXD, 4.7PF, 1KV, CER, 5%	1
C17, 19, 24, 26	23098	CAP-FXD, 10PF, CER, N750, 5%	4
C43	23112	CAP-FXD, 6.8PF, CER, N750	1
C48	23117	CAP-FXD, 2.7PF, CER, N750	1
C30, 34	23126	CAP-FXD, 120PF, 1KV, CER, 5%, N750	2
C2, 6, 8, 14, 15, 21, 22, 28	23133	CAP-FXD, .001MF, 500V, CER, 5%, Z5F	8
C29, 35, 41, 45, 46, 50	23135	CAP-FXD, 560PF, 100V, 5%, N1000	6
C16, 20, 23, 27, 37, 39	23137	CAP-FXD, 220PF, 100V, 5%, N1000	6
C18, 25, 42	23138	CAP-FXD, 180PF, 100V, 5%, N750	3
C3, 5, 32, 47, 49	23139	CAP-FXD, 100PF, 100V, 5%, N750	5
C52, 54	23140	CAP-FXD, 82PF, 100V, 5%, N470	2
C10, 12	23143	CAP-FXD, 47PF, 100V, 5%, N750	2
18	23146	CAP-FXD, 150PF, 100V, 10%, N750	1
C9, 13, 51, 55	23147	CAP-FXD, 360PF, 100V, 10%, N1000	4
C4, 36, 40	23148	CAP-FXD, 750PF, 100V, 10%, N1500	3
C1, 7	23164	CAP-FXD, 2200PF, 100V, 5%, NPO	2
C31, 33, 38	23173	CAP-FXD, 5PF, 500V, CER, 5%, N750	3
C11	23201	CAP-FXD, 270PF, 5%, 100V, N1500	1
	32025	SWITCH WAFER-ROTARY, PC MTG	2

80559 LOW LEVEL AMPLIFIER

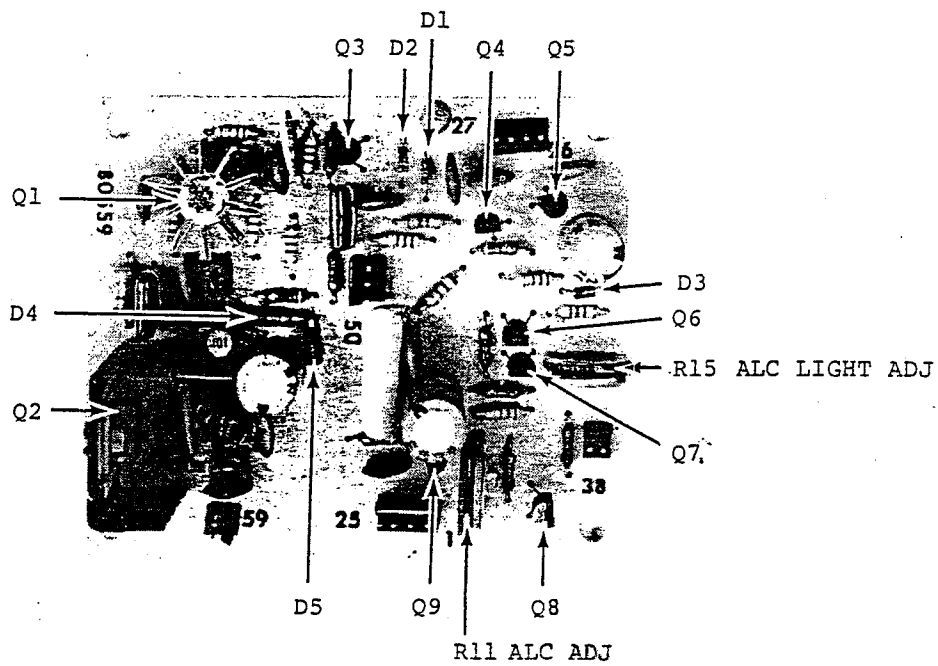
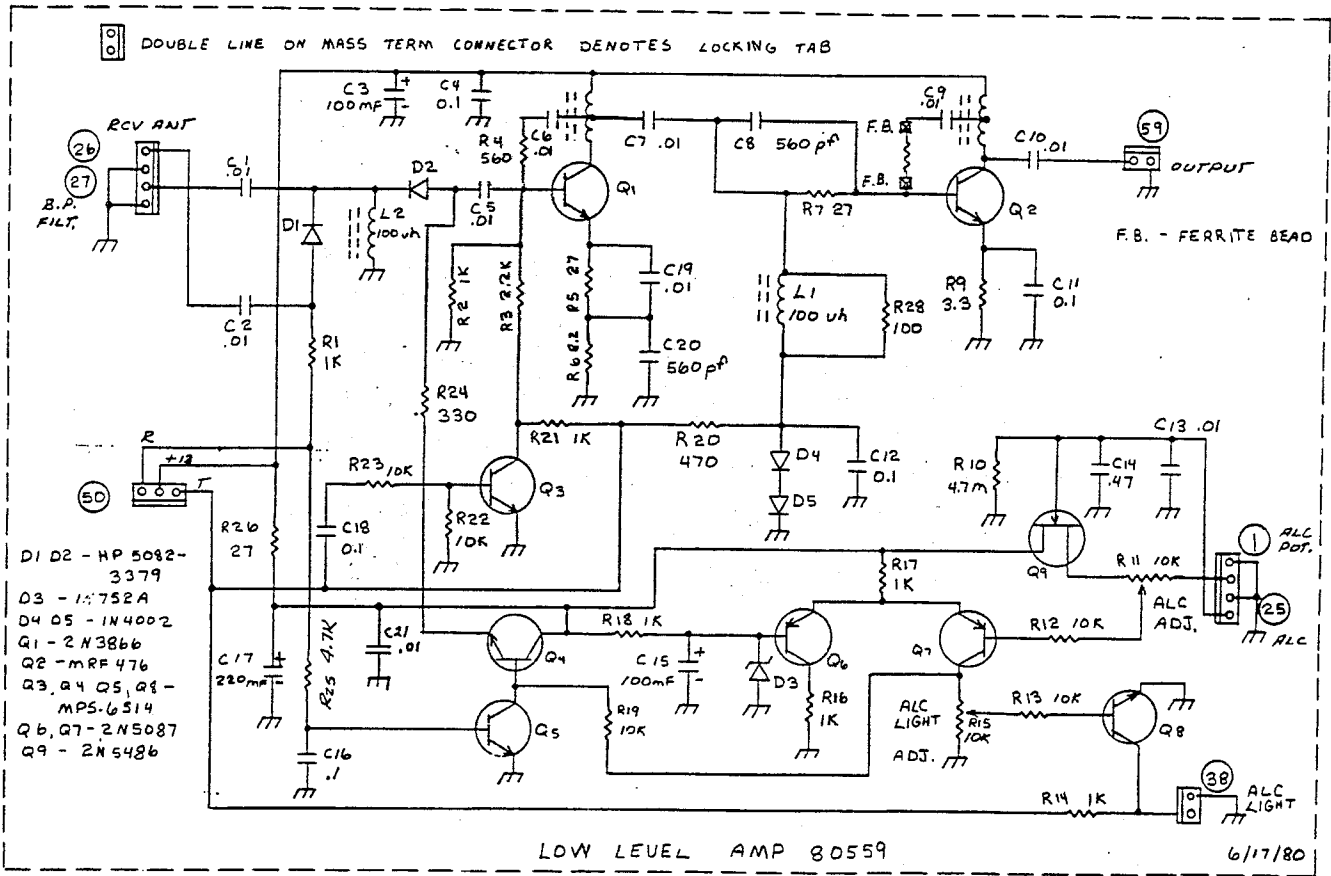

80559 LOW LEVEL AMPLIFIER

PARTS LIST

		QTY	
F.B.	BEAD CERO	2	21027
L1,2	CHOKE-RF, 100UH, 100MA	2	21060
C14	CAP-FXD, .47MF, 250V	1	23004
C4,11,12,16,18	CAP-FXD, 0.1MF, 250V, FILM, 20%	5	23006
C1,2,5,6,7,9,10,13,19,21	CAP-FXD, .01MF, 100V, CER, Z5V	10	23132
C8,20	CAP-FXD, 560PF, 100V, 5%, N1000	2	23135
C3,15	CAP-FXD, 100MF, 25V, EL, VERT.	2	23189
C17	CAP-FXD, 220MF, 16V, EL, VERT.	1	23202
Q6,7	TRANSISTOR-2N5087	2	25001
Q1	TRANSISTOR-RF POWER, 2N3866	1	25027
Q3,4,5,8	TRANSISTOR-MPS6514	4	25054
Q9	TRANSISTOR-2N5486	1	25060
Q2	TRANSISTOR, MRF-476	1	25081
D4,5	DIODE-POWER, 1N4002, SIL	2	28000
D3	DIODE-ZENER, 5.6V, 10%, 1N752A	1	28011
D1,2	DIODE-PIN	2	28020
R11,13	RES-VAR, 10K, LIN, PC MOUNT	2	30038
	TOROID-RF, 8T, #28 BIFILAR	1	85085
	TRANSFORMER-RF, BIFILAR NP	1	85120

TRANSISTOR	COIL (Drain)		BASE (Gate)		EMITTER (Source)	
	Receive	Transmit	Receive	Transmit	Receive	Transmit
Q1	13	13	0	2.05	0	1.35
Q2	13.0	13.0	0	1.26	0	.5
Q3	0	7.31	0	0	0	0
Q4	13	12.75	0	4.95	0	4.31
Q5	0	4.95	.75	0	0	0
Q6	0	0	5.45	5.45	4.17	5.38
Q7	4.10	5.36	3.54	4.75	4.17	5.38
Q8	0	.31	.57	.71	0	0
Q9	3.64	3.81	0	0	13.0	12.75

80565 FINAL AMPLIFIER

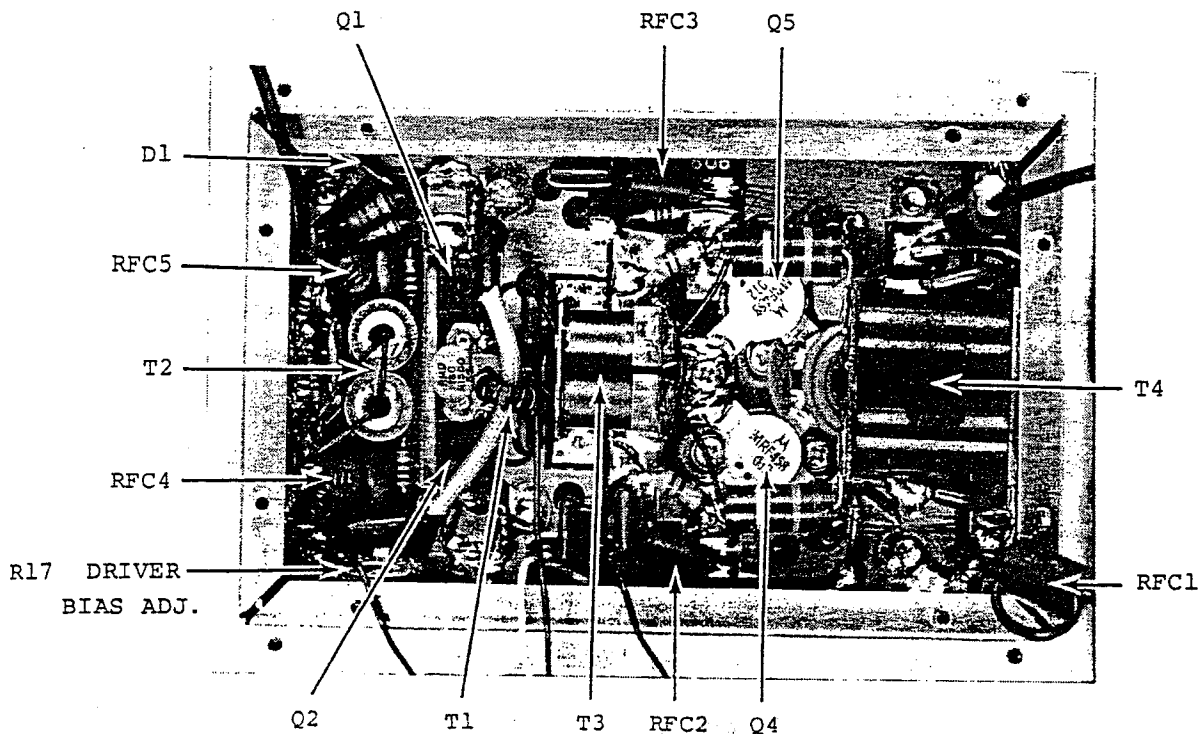

80565 FINAL AMPLIFIER

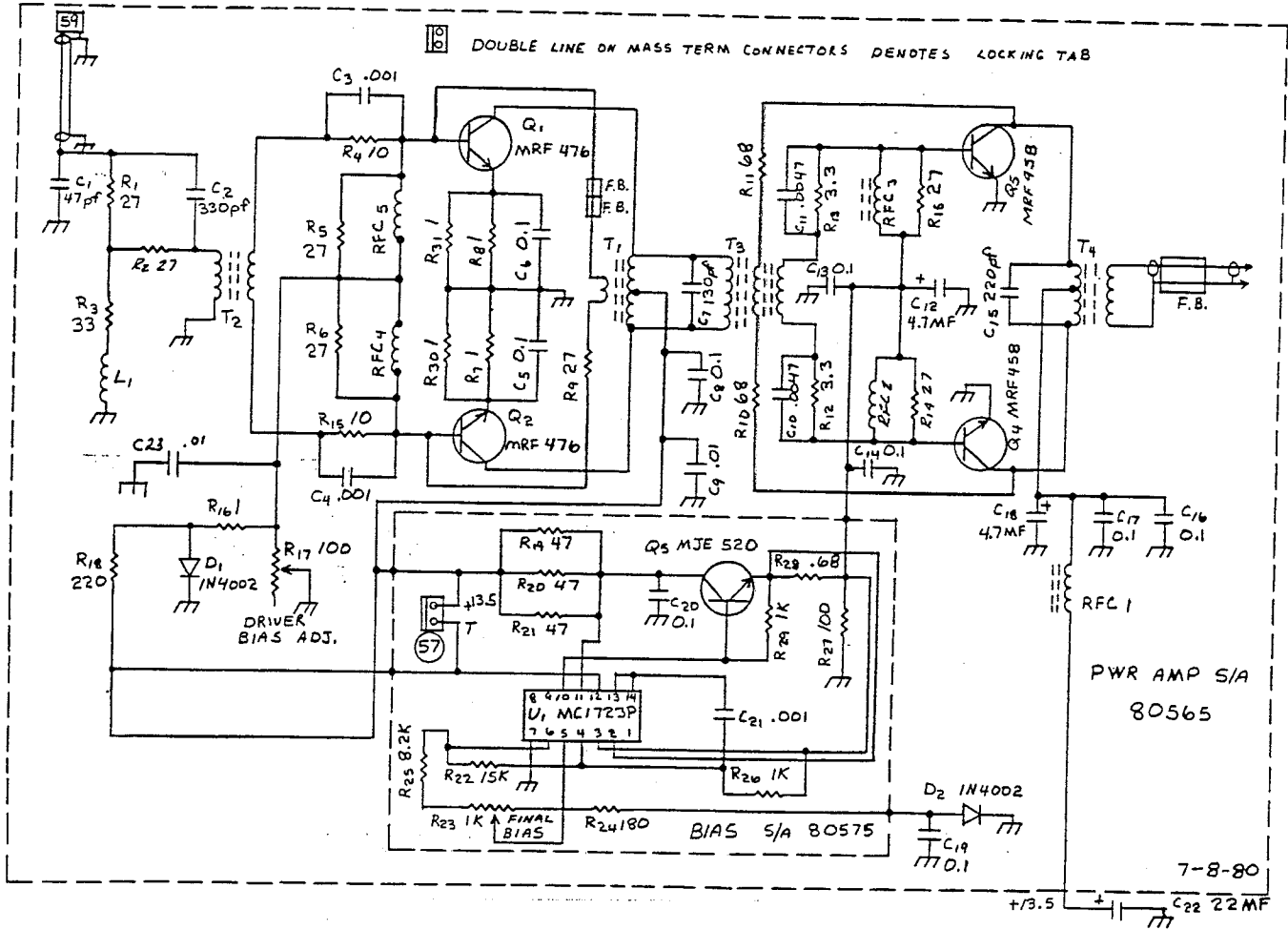

PARTS LIST

		QTY
	21027 BEAD CERO	2
	21029 BEAD-FERRITE	7
	21037 BEAD-FERRITE-TOROID	3
	21038 CORE-FERROXCUBE/VK211, 07/38	4
	21048 CORE-C11 MAT, .6200D, .312ID, X1	2
C8,13,14,16,17,19,23	23006 CAP-FXD, 0.1MF, 250V, FILM, 20%	7
C22	23060 CAP-FXD, 22MF, 35V, EL	1
C9	23132 CAP-FXD, .01MF, 100V, CER, Z5V	1
C3,4	23133 CAP-FXD, .001MF, 500V, CER, 5%, Z5F	2
C2	23136 CAP-FXD, 330PF, 100V, 5%, N1000	1
C1	23143 CAP-FXD, 47PF, 100V, 5%, N750	1
C7	23155 CAP-FXD, 130PF, 500V, 5%, N1500	1
C15	23156 CAP-FXD, 220PF, 500V, 5%, N1500	1
C10,11	23167 CAP-FXD, 4700PF, 100V, 5%, NPO, CER	2
C5,6	23184 CAP-FXD, .1MF, 20%, 100V, CER, CHIP	2
C12,18	23188 CAP-FXD, 4.7 MF, 25V, EL, VERT	2
Q4,5	25080 TRANSISTOR-MRF458	2
Q1,2	25081 TRANSISTOR-MRF476	2
D1,2	28000 DIODE-POWER, 1N4002, SIL	2

80575 BIAS

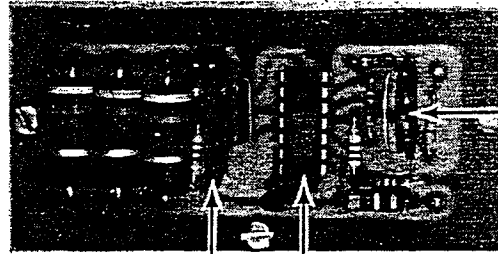

Q5 U1

R23 BIAS ADJ.

PARTS LIST			QTY
C20	23006	CAP-FXD, 0.1MF, 250V, FILM, 20%	1
C21	23133	CAP-FXD, .001MF, 500V, CER, 5%, Z5F	1
Q5	25002	TRANSISTOR-POWER, MJE520	1
U1	25050	TRANSISTOR-MC1723CL	1
R23	30070	RES-VAR, 1K, LIN, PC VERT MTG, 30%	1

80561 LOW PASS FILTER

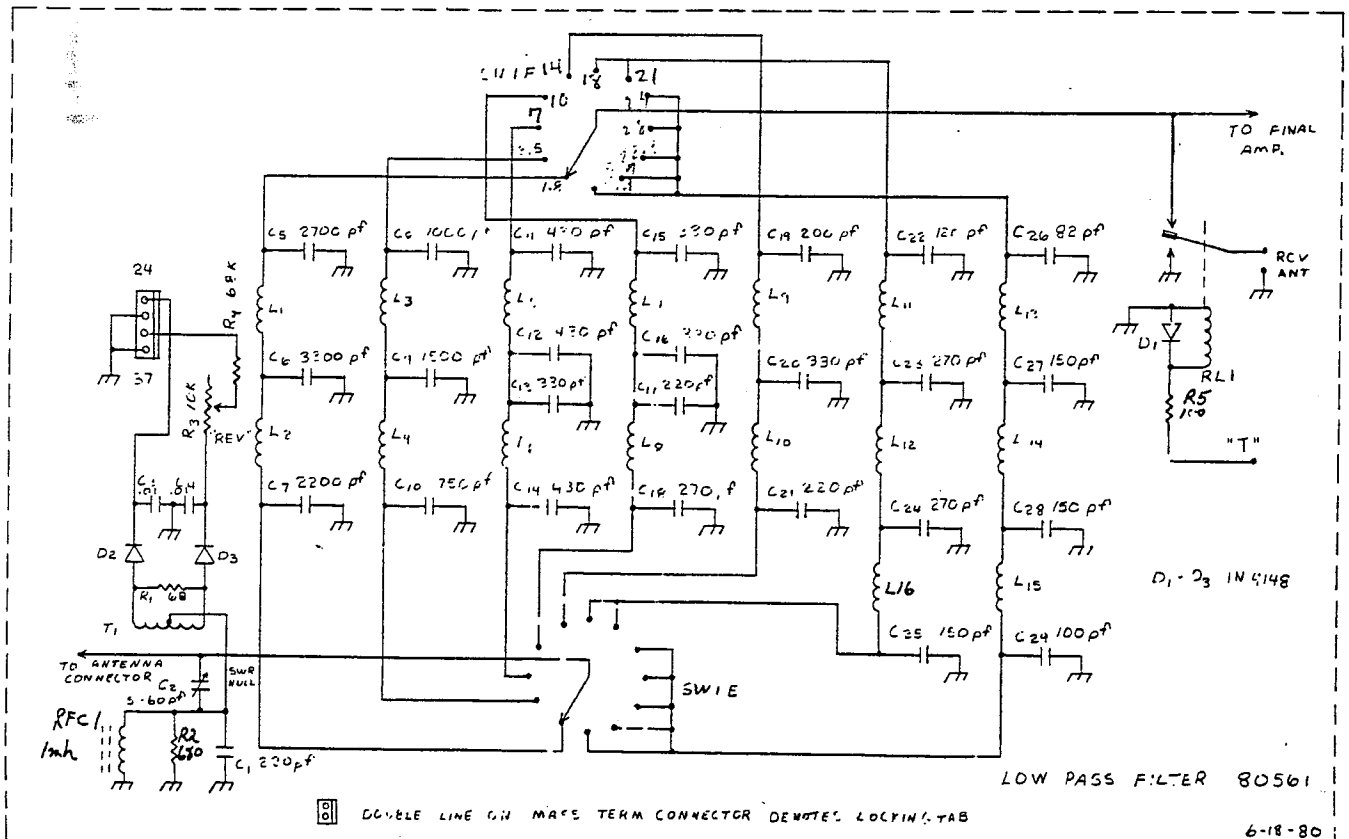

49-380

80561 LOW PASS FILTER

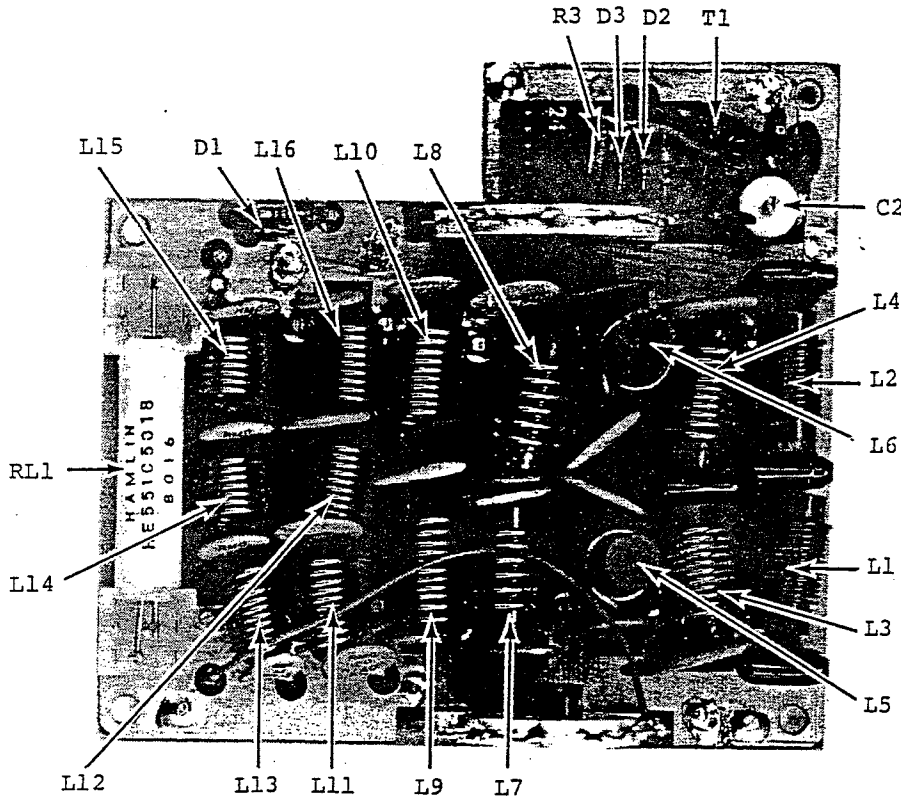

PARTS LIST

			QTY
RFC1	21007	CHOKE-RF, 1 MHY	1
C2	23061	CAP-VAR, 5/60PF, TRIMMER	1
C29	23125	CAP-FXD, 100PF, 1KV, CER, 5%, N750	1
C22	23126	CAP-FXD, 120PF, 1KV, CER, 5%, N750	1
C25,27,28	23127	CAP-FXD, 150PF, 1KV, CER, 5%, N1500	3
C19	23128	CAP-FXD, 200PF, 1KV, CER, 5%, N1500	1
C17,21	23129	CAP-FXD, 220PF, 1KV, CER, 5%, N1500	2
C3,4	23132	CAP-FXD, .01MF, 100V, CER, Z5V	2
C1	23137	CAP-FXD, 220PF, 100V, 5%, N1000	1
C8	23160	CAP-FXD, 1000PF, 500V, 5%, N2200	1
C13,15,16,20	23165	CAP-FXD, 330PF, 1KV, CER, 5%, N1500	4
C9	23170	CAP-FXD, 1500PF, 1KV, MICA, 5%	1
C7	23171	CAP-FXD, 2200PF, 1KV, MICA, 5%	1
C6	23172	CAP-FXD, 3300PF, 1KV, 5%, MICA 4	1
C18,23,24	23175	CAP-FXD, 270PF, 1KV, CER, 5%, N1500	3
C5	23176	CAP-FXD, 2700PF, 1KV, MICA, 5%	1
C10	23203	CAP-FXD, 750PF, 5%, 1KV, CER	1
C11,12,14	23205	CAP-FXD, 430PF, 5%, 1KV, CERAMIC	3
C26	23206	CAP-FXD, 82PF, 5%, 1KV, CER	1
D1-3	28001	DIODE-1N4148/1N914, SIL	3
R3	30038	RES-VAR, 10K, LIN, PC MOUNT	1
RL1	32007	RELAY-SPDT, PC MTG	1
	32025	SWITCH WAFER-ROTARY, PC MTG	2
T1	85085	TOROID-RF, 8T, #28 BIFILAR	1
L10,11	85110	COIL-RF, AIR, 10T, #16	2
L9	85111	COIL-RF, AIR, 11T, #16	1
L1	85137	COIL-RF, 4 UH, 14T, #19	1
L2	85138	COIL-RF, 3.1UH, 12T, #19	1
L4	85139	COIL-RF, 2.1 UH, 10T, #16	1
L5,6	85140	COIL-RF, 1.2 UH, 7-1/2T, #16	2
L3	85141	COIL-RF, 2.3UH, 11T, #16	1
L7,8	85142	COIL-RF, .9UH, 6T, #16	2
L14,15	85143	COIL-RF, .27UH (AIR), 7T #16	2
L12,16	85144	COIL-RF, 9T #16, 5/16" D	2
L13	85145	COIL-RF, 10T, #16, 5/16 D	1

80566 VOX

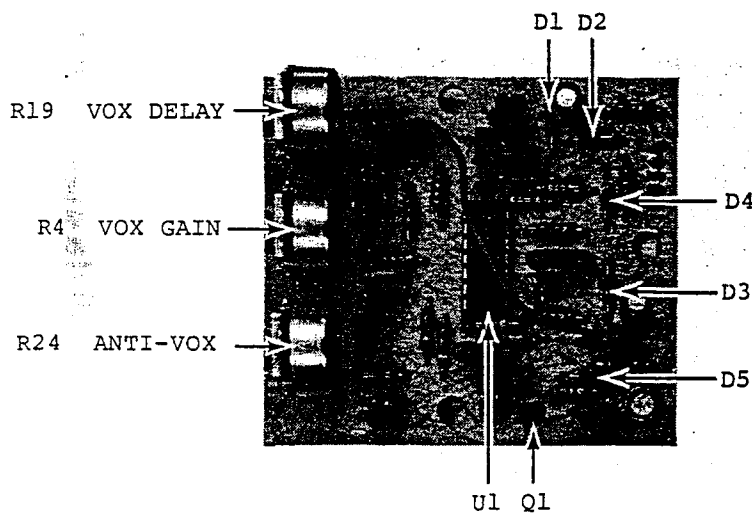
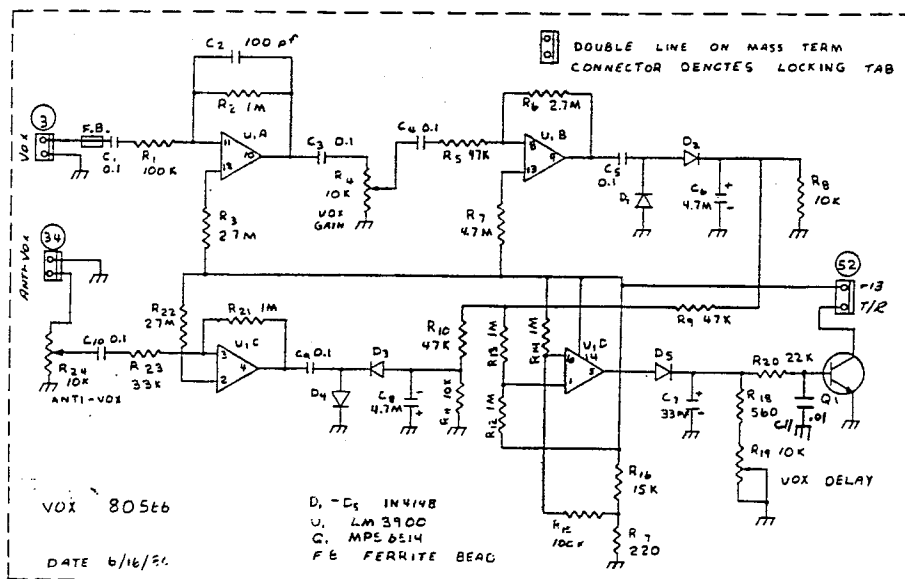

PIN	VOLTAGE
1	.54
2	.52
3	.52
4	5.19
5	.11
6	.52
7	0
8	.51
9	7.76
10	5.22
11	.52
12	.52
13	.52
14	13.0

PARTS LIST

QTY			
1	F.B.	21027	BEAD CERO
6	C1,3,4,5,9,10	23006	CAP-FXD, 0.1MF, 250V, FILM, 20%
1	C11	23132	CAP-FXD, .01MF, 100V, CER, Z5V
1	C2	23139	CAP-FXD, 100PF, 100V, 5%, N750
1	C7	23182	CAP-FXD, 33MF, 16V, EL VERT
2	C6,8	23188	CAP-FXD, 4.7MF, 25V, EL VERT
1	Q1	25054	TRANSISTOR-MPS6514
1	U1	25068	IC-LM3900N
5	D1-5	28001	DIODE-1N4148/1N914, SIL
3	R4,19,24	30199	RES-VAR, 10K, LIN, PC BUSHING

(In VOX Position) - (Receive mode)

TRANSISTOR	COLLECTOR	BASE	EMITTER
Q1	4.67	0	0

80545 LOGIC BOARD

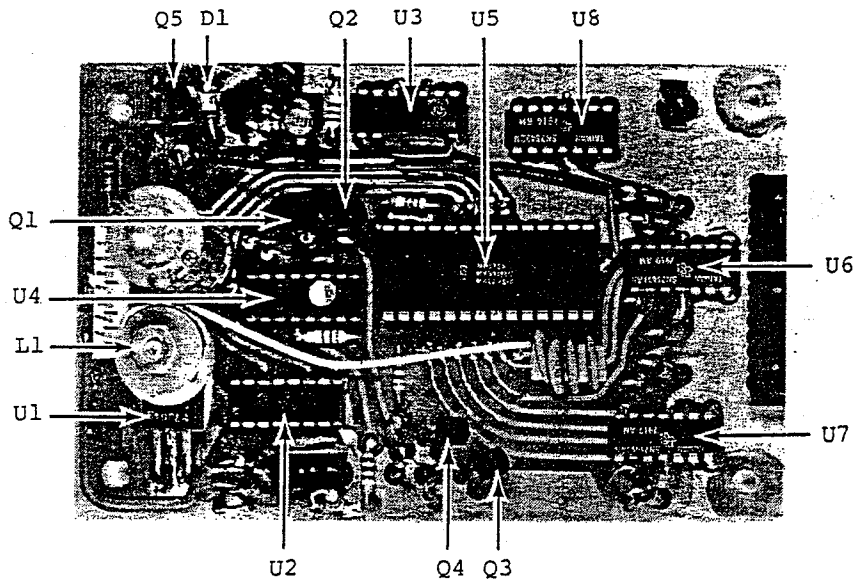
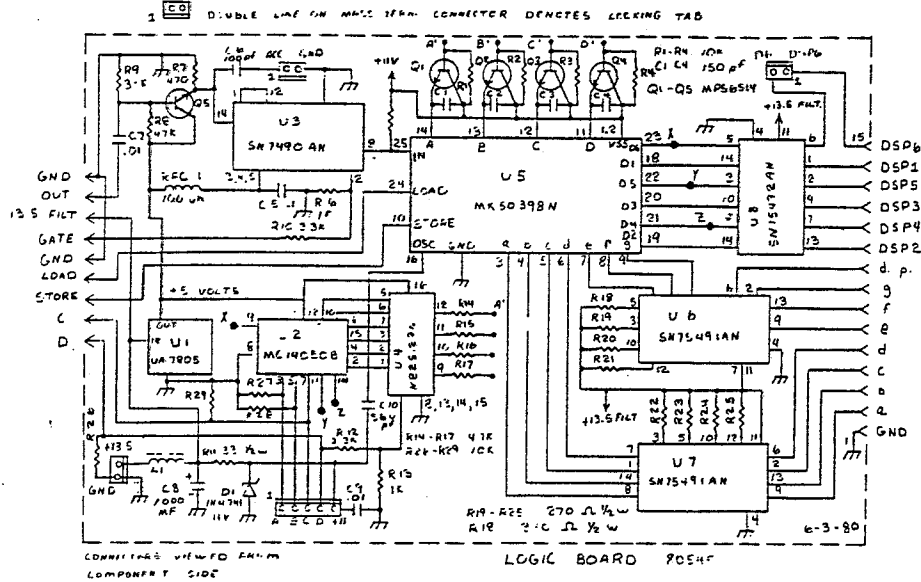

PARTS LIST		QTY
RFC1	21060	1
C5	23006	1
C7,9	23132	2
C10	23135	1
C6	23139	1
C1-4	23146	4
C8	23200	1
Q1-5	25054	5
U3	25056	1
U2	25057	1
U5	25070	1
U8	25071	1
U6,7	25074	2
U1	25095	1
D1	28007	1
L1	85032	1
U4	98071	1
	CHOKE-RF, 100UH, 100MA	
	CAP-FXD, 0.1MF, 250V, FILM, 20%	
	CAP-FXD, .01MF, 100V, CER, Z5V	
	CAP-FXD, 560PF, 100V, 5%, N1000	
	CAP-FXD, 100PF, 100V, 5%, N750	
	CAP-FXD, 150PF, 100V, 10%, N750	
	CAP-FXD, 1000MF, 16V, EL, VERT	
	TRANSISTOR-MPS6514	
	IC-DECADE COUNTER	
	IC-MC14050CP	
	IC-COUNTER, MK50398N	
	IC-75492APC	
	IC-75491APC	
	IC-MC7805CP	
	DIODE-ZENER, 11V, 10%, 1N4741	
	COIL-CHOKE, 160T, #25	
	PT. NO. 25097 PROGRAMMED	

80549 PRESET CONTROL

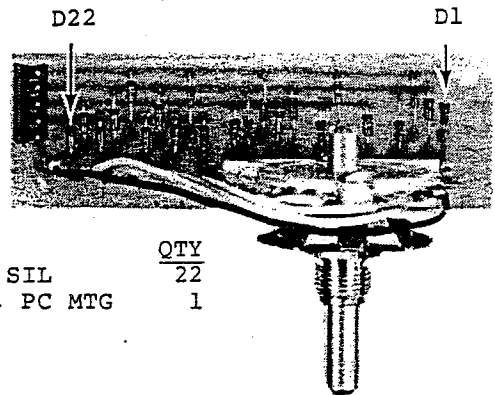
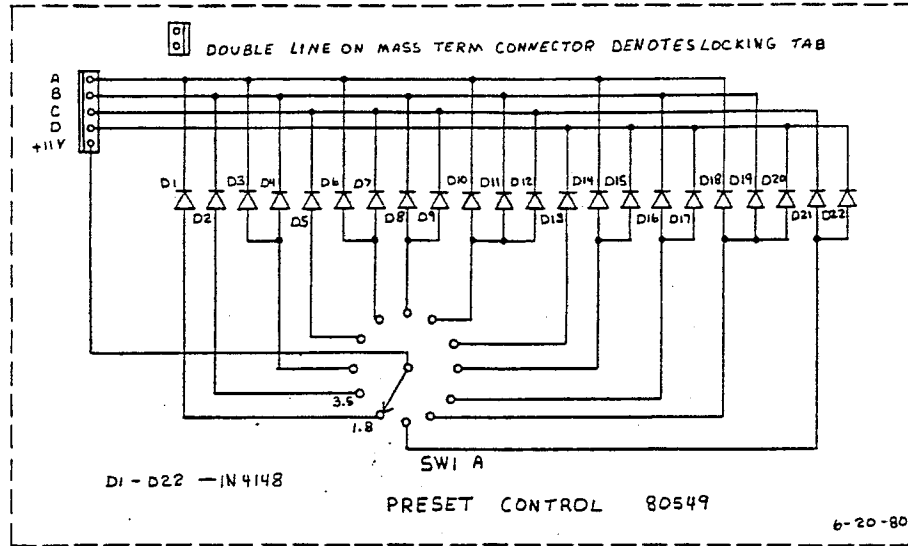

PARTS LIST		QTY
D1-D22	28001 DIODE-1N4148/1N914, SIL	22
	32025 SWITCH WAFER-ROTARY, PC MTG	1

80544 TIMEBASE/PREAMP

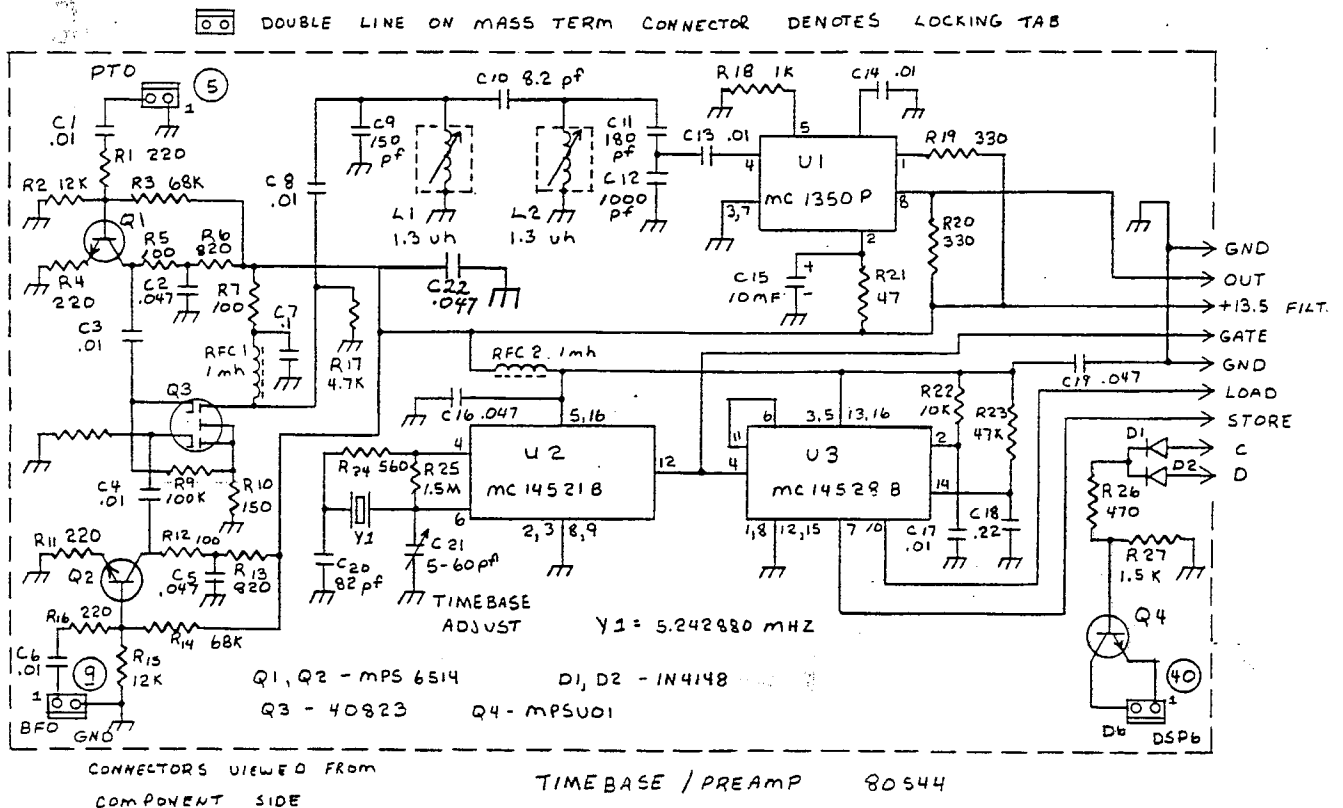

80544 TIMEBASE/PREAMP

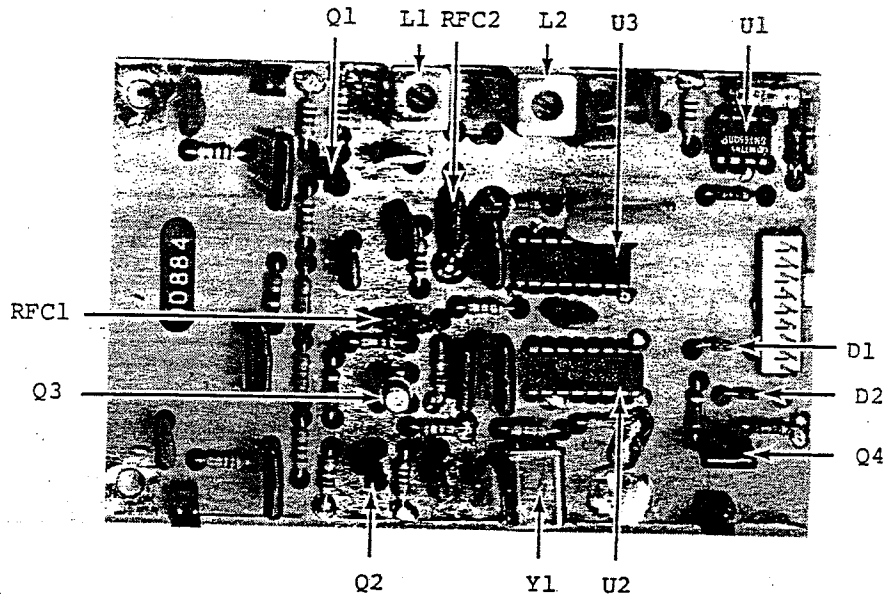

PARTS LIST			QTY
RFC1,2	21007	CHOKE-RF, 1MHY	2
L1,2	21058	COIL-SHIELDED, 1.3UH	2
C7	23006	CAP-FXD, 0.1MF, 250V, FILM, 20%	1
C18	23012	CAP-FXD, 0.22MF, 250V, FILM, 20%	1
C2,5,16,17,22	23048	CAP-FXD, .047MF, 250V, FILM, 20%	5
C21	23061	CAP-VAR, 5/60PF, TRIMMER	1
C10	23116	CAP-FXD, 8.2PF, CER, N750	1
C1,3,4,6,8,13,14,17	23132	CAP-FXD, .01MF, 100V, CER, Z5V	8
C12	23133	CAP-FXD, .001MF, 500V, CER, 5%, Z5F	1
C11	23138	CAP-FXD, 180PF, 100V, 5%, N750	1
C20	23140	CAP-FXD, 82PF, 100V, 5%, N470	1
C9	23146	CAP-FXD, 150PF, 100V, 10%, N750	1
C15	23174	CAP-FXD, 10MF, 16V, EL	1
Q3	25022	TRANSISTOR-FET, 40823	1
Q4	25053	TRANSISTOR-MPSU01	1
Q1,2	25054	TRANSISTOR-MPS6514	2
U2	25058	IC-MC145211CP DIVIDER/XTAL OSC	1
U3	25059	IC-MC14528CP MONOSTABLE MV	1
U1	25062	IC-MC1350P	1
D1,2	28001	DIODE-1N4148/1N914, SIL	2
Y1	48016	CRYSTAL-QUARTZ, 5.24288MHZ	1

80547 DISPLAY BOARD

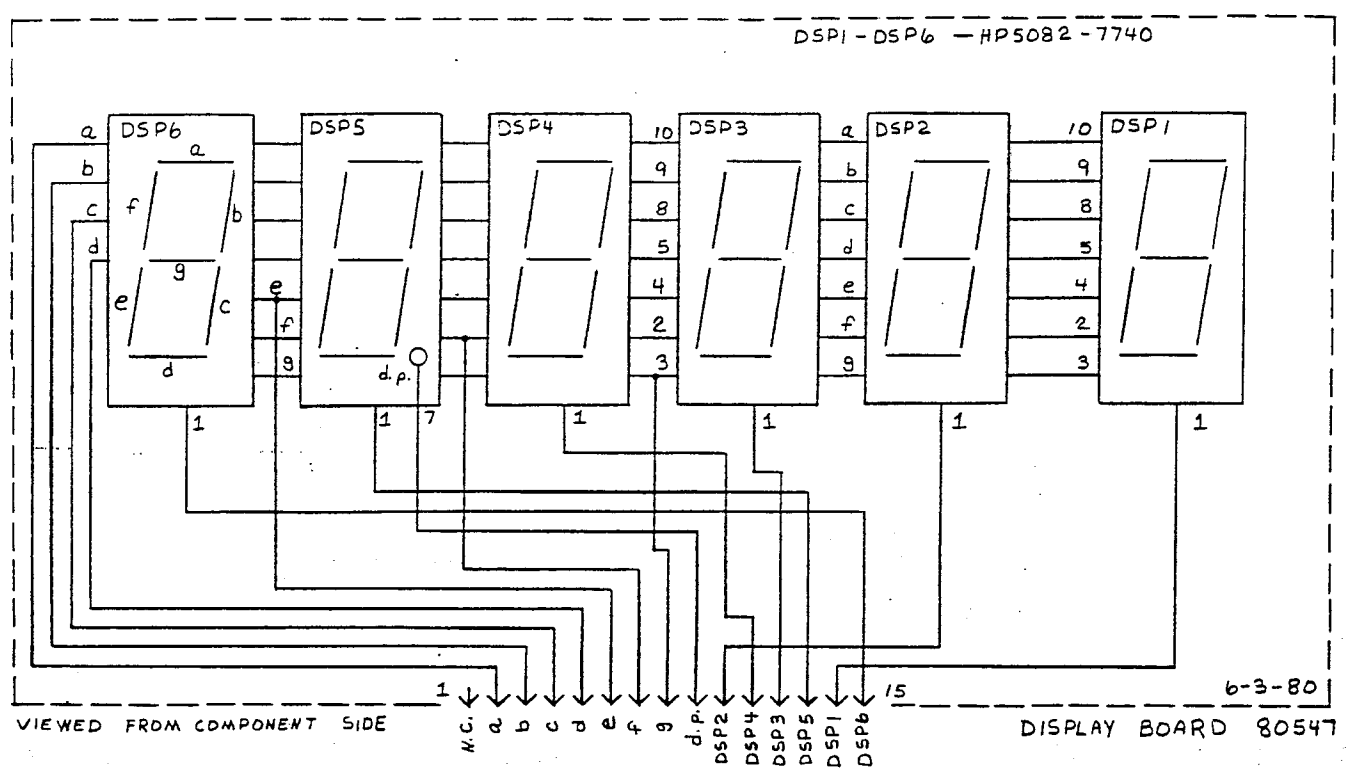

PARTS LIST		QTY
28028	DISPLAY-LED, RED, 5082/7740	6
35097	CONNECTOR-WAFER, 15 CIRCUIT	1

Ten-Tec, Inc.
1185 Dolly Parton Parkway
Sevierville, TN 37862
Repair Service: (865) 428-0364

LIMITED WARRANTY AND SERVICE POLICY, U.S.A. AND CANADA

Ten-Tec, Inc., warrants this product to be free from defects in material and workmanship for a period of one (1) year from the date of purchase, under these conditions:

1. **THIS WARRANTY APPLIES ONLY TO THE ORIGINAL OWNER.** It is important that the warranty registration card be sent to us promptly.
2. **READ THE MANUAL THOROUGHLY.** This warranty does not cover damage resulting from improper operation. Developing a thorough understanding of this equipment is your responsibility.
3. **IF TROUBLE DEVELOPS** we recommend you contact our customer service group direct at the address or phone number shown above. It has been our experience that factory direct service is expeditious and usually results in less down-time on the equipment. Some overseas dealers do offer warranty service and, of course, have our complete support.
4. **EQUIPMENT RETURNED TO THE FACTORY** must be properly packaged, preferably in the original shipping carton(s). You pay the freight to us and we prepay surface freight back to you. Canadian customers must have proper customs documentation sent with incoming repair equipment. Duties or fees charged due to improper documenting are the responsibility of the owner of the equipment.
5. **EXCLUSIONS.** This warranty does not cover damage resulting from misuse, lightning, excess voltages, polarity errors or damage resulting from modifications not recommended or approved by Ten-Tec. In the event of transportation damage, a claim must be filed with the carrier. Under no circumstances is Ten-Tec liable for consequential damages to persons or property caused by the use of this equipment.
6. **TEN-TEC RESERVES** the right to make design changes without any obligation to modify equipment previously manufactured, or to notify owners of changes to existing equipment.
7. **THIS WARRANTY** is given in lieu of any other warranty, expressed or implied.

SERVICE OUTSIDE OF THE U.S.A. OR CANADA

Many of our international dealers provide warranty service on the equipment they sell. Many of them also provide out of warranty service on all equipment whether they sold it or not. If your dealer does not provide service or is not conveniently located, follow the procedure outlined above. Equipment returned to us will be given the same attention as domestic customers but roundtrip freight expense, customs and broker fees will be paid by you.

Part no. 74244