

TEN - TEC

**OPERATOR'S
MANUAL**

**OMNI V
HF TRANSCEIVER
MODEL 562**

TABLE OF CONTENTS

<u>PARAGRAPH</u>	<u>PAGE</u>
LIST OF ILLUSTRATIONS	v
LIST OF TABLES	vii
INTRODUCTION	viii
UNPACKING	viii
SPECIFICATIONS	ix
1. INSTALLATION	
1-1 INTRODUCTION	1-1
1-2 FIXED STATION & MOBILE	1-1
1-3 POWER SUPPLY	1-1
1-4 ANTENNAS	1-2
1-5 MICROPHONE	1-2
1-6 KEY	1-2
1-7 GROUND	1-2
1-8 BATTERY BACKUP	1-2
2. CONDENSED OPERATING INSTRUCTIONS	
2-1 INTRODUCTION	2-1
2-2 SELECTING FREQUENCY	2-1
2-3 INITIAL FRONT PANEL SETTINGS	2-1
2-4 TRANSMIT	2-1
3. DETAILED OPERATING INSTRUCTIONS	
3-1 KEYPAD FUNCTIONS	3-1
3-1.1 SELECTING MODE	3-1
3-1.2 CRYSTAL FILTER SELECTION	3-1
3-1.3 TUNE	3-1
3-1.4 VOICE/CALENDAR ENABLE	3-1
3-1.5 REV	3-2
3-1.6 VFO SELECTION / OFFSET TUNING	3-2
3-1.7 TUNING RATES	3-2
3-1.8 BAND SELECTION	3-3
3-1.9 DOWN / UP	3-3

TABLE OF CONTENTS (continued)

<u>PARAGRAPH</u>	<u>PAGE</u>
3-2 MEMORIES	3-3
3-2.1 SCRATCH PAD MEMORY	3-3
3-2.2 MEMORY STORE	3-3
3-2.3 MEMORY TUNE	3-4
3-2.4 MEMORY RECALL	3-4
3-2.5 MEMORY CLEAR	3-4
3-3 CLOCK-CALENDAR FUNCTIONS	3-4
3-3.1 CLOCK DISPLAY	3-4
3-3.2 CLOCK SET	3-4
3-3.3 DATE SET	3-5
3-3.4 WWV REMINDER	3-5
3-3.5 SYSTEM RESET SWITCH	3-5
3-4 FRONT PANEL FUNCTIONS	3-5
3-4.1 DISPLAY AREA	3-5
3-4.2 AF GAIN/TONE	3-5
3-4.3 METER & SWITCH	3-5
3-4.4 NOISE BLANKER	3-6
3-4.5 ATTENUATOR	3-6
3-4.6 BPF/FADE	3-6
3-4.7 PBT/NOTCH	3-6
3-4.8 MIC/RF PWR	3-6
3-4.9 PROC	3-7
3-4.10 RF/SQL	3-7
3-4.11 AGC FAST/SLOW & ON/OFF	3-7
3-4.12 VOX/PTT	3-7
3-4.13 QSK FAST/SLOW	3-7
3-4.14 PWR	3-7
3-4.15 PHONES	3-7
3-4.16 MIC	3-7
3-5 REAR PANEL FUNCTIONS	3-11
3-5.1 POWER SOCKET	3-11
3-5.2 GROUND POST	3-11
3-5.3 FUSE	3-11
3-5.4 ANTENNA	3-11
3-5.5 RECEIVE ANTENNA	3-11
3-5.6 CW SIDETONE	3-11
3-5.7 VOX CONTROLS	3-11
3-5.8 SSB MONITOR LEVEL	3-11
3-5.9 BEEP/VOICE	3-11
3-5.10 KEY	3-11
3-5.11 XVRT EN/XVRT OUT	3-12

TABLE OF CONTENTS (continued)

<u>PARAGRAPH</u>	<u>PAGE</u>
3-5.12 AF OUT	3-12
3-5.13 TX EN/TX OUT	3-12
3-5.14 PTT	3-12
3-5.15 AUX 13.8	3-12
3-5.16 AUDIO IN	3-12
3-5.17 EXT. SPKR.....	3-12
3-5.18 RELAY	3-12
3-5.19 RTTY KEY.....	3-12
3-5.20 MARK/SPACE.....	3-12
4. OPERATING HINTS	
4-1 INTRODUCTION	4-1
4-1.1 CW	4-1
4-1.2 FM.....	4-1
4-1.3 FSK (RTTY)	4-1
4-1.4 PROTECTIVE CIRCUITRY & ALC	4-1
4-1.5 SOLID STATE POWER AMPLIFIERS	4-2
4-1.6 BROADBAND vs RESONANT TANKS	4-2
4-1.7 SWR - Two Kinds	4-3
4-1.8 EFFICIENCY	4-3
5. OPTIONS INSTALLATION	
5-1 INTRODUCTION	5-1
5-1.1 REMOVAL OF TOP & BOTTOM COVERS	5-1
5-1.2 "MASS TERM" CONNECTORS	5-1
5-1.3 CRYSTAL FILTERS	5-1
5-1.4 VOICE READOUT	5-2
5-1.5 FM ADAPTER	5-2
6. CIRCUIT DESCRIPTIONS AND ILLUSTRATIONS	
6-1 INTRODUCTION	6-1
6-2 TRANSMIT LOWPASS FILTER (81455)	6-5
6-3 BAND PASS FILTER (81409)	6-9
6-4 XTAL OSC-LO MIXER (81408)	6-13
6-5 9 MHZ CRYSTAL FILTER (81410)	6-17
6-6 PASSBAND TUNING BOARD (81460)	6-21
6-7 IF / AF BOARD (81462)	6-25

TABLE OF CONTENTS (continued)

<u>PARAGRAPH</u>	<u>PAGE</u>
6-8 PHASE LOCKED LOOP BLOCK DIAGRAM	6-29
6-9 5.0-5.5 MHZ PLL BOARD (81459)	6-31
6-10 CONTROL BOARD (81456)	6-35
6-11 SWITCH BOARD (81327)	6-39
6-12 UPPER POT BOARD (81326)	6-43
6-13 LOWER POT BOARD (81325)	6-47
6-14 SIDETONE BOARD (81362)	6-51
6-15 TRANSMIT AUDIO/BFO BOARD (81457)	6-55
6-16 LOW LEVEL AMPLIFIER / NOISE BLANKER (81340)	6-61
6-17 RF POWER AMPLIFIER (81342) and PA BIAS BOARD (81343)	6-65
6-18 LOGIC BOARD (81442)	6-71
6-19 KEYPAD BOARD (81446)	6-77
6-20 VF DISPLAY DRIVER BOARD (81447)	6-83
6-21 VF DISPLAY BOARD (81448)	6-87
6-22 DC POWER BOARD (81328)	6-91
6-23 VOICE READOUT BOARD (81361)	6-95
6-24 RS232 CONNECTOR BOARD (81425)	6-99

LIST OF ILLUSTRATIONS

<u>FIGURE</u>	<u>PAGE</u>
1-1 POWER SUPPLY CONNECTIONS	1-1
3-1 MIC CONNECTIONS	3-8
3-2 MODEL 562 FRONT PANEL	3-9
3-3 MODEL 562 REAR PANEL.....	3-10
5-1 MASS TERM CONNECTOR	5-1
5-2 PBT CRYSTAL FILTER LOCATIONS.....	5-1
5-3 9 MHZ IF CRYSTAL FILTER OPTION	5-2
5-4 MODEL 257 OPTION INSTALLATION DIAGRAM	5-2
5-5 MODEL 562 ADJUSTMENTS (BOTTOM VIEW).....	5-3
5-6 MODEL 562 TOP VIEW	5-5
5-7 MODEL 562 BOTTOM VIEW	5-6
5-8 QSK HOOK-UP WITH HERCULES II AMPLIFIER	5-7
5-9 QSK HOOK-UP WITH TITAN AMPLIFIER.....	5-7
5-10A IBM PC RS232 CONNECTOR CABLE	5-9
5-10B APPLE MACINTOSH RS232 CONNECTOR CABLE	5-9
5-10C COMMODORE 64/128 RS232 CONNECTOR CABLE	5-10
5-10D APPLE IIC/E RS232 CONNECTOR CABLE	5-11
6-1 OVERALL BLOCK DIAGRAM	6-3
6-2 81455 TRANSMIT LOW PASS FILTER CIRCUIT TRACE.....	6-6
6-3 81455 TRANSMIT LOW PASS FILTER COMPONENT LAYOUT	6-6
6-4 81455 TRANSMIT LOW PASS FILTER SCHEMATIC.....	6-7
6-5 81409 BAND PASS FILTER CIRCUIT TRACE	6-10
6-6 81409 BAND PASS FILTER COMPONENT LAYOUT.....	6-10
6-7 81409 BAND PASS FILTER SCHEMATIC.....	6-11
6-8 81408 XTAL OSC-LO MIXER CIRCUIT TRACE	6-14
6-9 81408 XTAL OSC-LO MIXER COMPONENT LAYOUT	6-14
6-10 81408 XTAL OSC-LO MIXER SCHEMATIC	6-15
6-11 81410 9MHZ CRYSTAL FILTER CIRCUIT TRACE.....	6-18
6-12 81410 9MHZ CRYSTAL FILTER COMPONENT LAYOUT	6-18
6-13 81410 9MHZ CRYSTAL FILTER SCHEMATIC.....	6-19
6-14 81460 PASS BAND TUNING BOARD CIRCUIT TRACE	6-22
6-15 81460 PASS BAND TUNING BOARD COMPONENT LAYOUT	6-22
6-16 81460 PASS BAND TUNING BOARD SCHEMATIC	6-23
6-17 81462 IF / AF BOARD CIRCUIT TRACE	6-26
6-18 81462 IF / AF BOARD COMPONENT LAYOUT	6-26
6-19 81462 IF / AF BOARD SCHEMATIC	6-27
6-20 PHASE LOCKED LOOP BLOCK DIAGRAM	6-28
6-21 81459 5.0-5.5 MHZ PLL BOARD CIRCUIT TRACE	6-32
6-22 81459 5.0-5.5 MHZ PLL BOARD COMPONENT LAYOUT	6-32
6-23 81459 5.0-5.5 MHZ PLL BOARD SCHEMATIC	6-33
6-24 81456 CONTROL BOARD CIRCUIT TRACE	6-36

LIST OF ILLUSTRATIONS (continued)

<u>FIGURE</u>	<u>PAGE</u>
6-25 81456 CONTROL BOARD COMPONENT LAYOUT	6-36
6-26 81456 CONTROL BOARD SCHEMATIC	6-37
6-27 81327 SWITCH BOARD CIRCUIT TRACE	6-40
6-28 81327 SWITCH BOARD COMPONENT LAYOUT	6-40
6-29 81327 SWITCH BOARD SCHEMATIC	6-41
6-30 81326 UPPER POT BOARD CIRCUIT TRACE	6-44
6-31 81326 UPPER POT BOARD COMPONENT LAYOUT	6-44
6-32 81326 UPPER POT BOARD SCHEMATIC	6-45
6-33 81325 LOWER POT BOARD CIRCUIT TRACE	6-48
6-34 81325 LOWER POT BOARD COMPONENT LAYOUT	6-48
6-35 81325 LOWER POT BOARD SCHEMATIC	6-49
6-36 81362 SIDETONE BOARD CIRCUIT TRACE	6-52
6-37 81362 SIDETONE BOARD COMPONENT LAYOUT	6-52
6-38 81362 SIDETONE BOARD SCHEMATIC	6-53
6-39 81457 TRANSMIT AUDIO/BFO BOARD CIRCUIT TRACE	6-58
6-40 81457 TRANSMIT AUDIO/BFO BOARD COMPONENT LAYOUT	6-58
6-41 81457 TRANSMIT AUDIO/BFO BOARD SCHEMATIC	6-59
6-42 81340 L. L. AMPLIFIER / NOISE BLANKER CIRCUIT TRACE	6-62
6-43 81340 L. L. AMPLIFIER / NOISE BLANKER COMPONENT LAYOUT	6-62
6-44 81340 L. L. AMPLIFIER / NOISE BLANKER SCHEMATIC	6-63
6-45 81342 RF POWER AMPLIFIER CIRCUIT TRACE	6-66
6-46 81342 RF POWER AMPLIFIER COMPONENT LAYOUT	6-66
6-47 81343 PA BIAS BOARD CIRCUIT TRACE	6-67
6-48 81343 PA BIAS BOARD COMPONENT LAYOUT	6-67
6-49 81342 RF POWER AMP. and 81343 PA BIAS BOARD SCHEMATIC	6-69
6-50 81442 LOGIC BOARD CIRCUIT TRACE	6-73
6-51 81442 LOGIC BOARD COMPONENT LAYOUT	6-74
6-52 81442 LOGIC BOARD SCHEMATIC	6-75
6-53 81446 KEYPAD BOARD CIRCUIT TRACE	6-78
6-54 81446 KEYPAD BOARD COMPONENT LAYOUT	6-79
6-55 81446 KEYPAD BOARD SCHEMATIC	6-81
6-56 81447 VF DISPLAY DRIVER BOARD CIRCUIT TRACE	6-84
6-57 81447 VF DISPLAY DRIVER BOARD COMPONENT LAYOUT	6-84
6-58 81447 VF DISPLAY DRIVER BOARD SCHEMATIC	6-85
6-59 81448 VF DISPLAY BOARD CIRCUIT TRACE	6-88
6-60 81448 VF DISPLAY BOARD COMPONENT LAYOUT	6-88
6-61 81448 VF DISPLAY BOARD SCHEMATIC	6-89
6-62 81328 DC POWER BOARD CIRCUIT TRACE	6-92
6-63 81328 DC POWER BOARD COMPONENT LAYOUT	6-92
6-64 81328 DC POWER BOARD SCHEMATIC	6-93
6-65 81361 VOICE READOUT BOARD CIRCUIT TRACE	6-96

LIST OF ILLUSTRATIONS (continued)

<u>FIGURE</u>		<u>PAGE</u>
6-66	81361 VOICE READOUT BOARD COMPONENT LAYOUT	6-96
6-67	81361 VOICE READOUT BOARD SCHEMATIC	6-97
6-68	81425 RS232 CONNECTOR BOARD CIRCUIT TRACE	6-100
6-69	81425 RS232 CONNECTOR BOARD COMPONENT LAYOUT	6-100
6-70	81425 RS232 CONNECTOR BOARD SCHEMATIC	6-101

LIST OF TABLES

<u>TABLE</u>		<u>PAGE</u>
3-1	IF CRYSTAL FILTERS	3-1
3-2	TUNING RATES	3-2
4-1	TROUBLE SHOOTING CHART	4-4
6-1	RS232 CONNECTOR PINOUTS	6-99
6-2	RS232 OMNI V COMMAND CODE CHART	6-103

INTRODUCTION

The OMNI V is a microprocessor controlled HF transceiver incorporating the latest digital technology. The OMNI V features an advanced phase locked loop synthesizer combined with a crystal mixed oscillator for superior phase noise performance. The OMNI V also provides a large easy to read vacuum fluorescent display, instant keypad band change, dual digital VFOs, 25 nonvolatile RAM memories (which store frequency, band, mode, and I-F bandwidth), memory tune via the main tuning knob, built-in 24 hour clock/calendar and all solid state design including the broadband "no tune" final power amplifier.

The OMNI V covers all amateur bands using CW (with full or semi break-in), SSB

(with built-in speech processor), RTTY (true FSK or AFSK), and optional FM. In addition, an optional narrow 9 MHz IF filter may be switched in to provide even better selectivity and noise rejection.

Chapters 1 and 2 of this manual cover installation and basic operation of the transceiver in order to quickly place the OMNI V into operation. Chapters 3 and 4 provide a more detailed description of the OMNI V's features, controls, and operation. Chapter 5 describes the options available for the OMNI V and how they should be installed. Chapter 6 is the technical reference section and contains detailed circuit descriptions, circuit board pictorials and schematic diagrams.

UNPACKING

Examine your Model 562 OMNI V for signs of shipping damage. Should any damage be apparent, notify the delivering carrier or dealer immediately, stating the full extent of the damage. Retain all damaged cartons. Liability for shipping damage rests with the carrier.

It is recommended that you keep the shipping carton and fillers in the event that storage, moving or reshipment becomes necessary. The following hardware and

accessories are packed with your OMNI V. Make sure that you have not overlooked anything.

1—#38040	.050" Allen Wrench
1—#38057	4 Pin Cable Connector
4—#41020	Female Terminal Pins
1—#74020	Warranty Card
1—#74199	Operator's Manual

If any of the above items are missing, contact the customer service department at Ten-Tec for replacements.

SPECIFICATIONS

GENERAL

FREQUENCY RANGE	Transmit and receive on all ham bands from 160 through 10 meters in their entirety. Twelve 500 kHz segments plus 30 kHz over-shoot at each band end.
FREQUENCY CONTROL	Microprocessor controlled digital PLL synthesizer with crystal mixed oscillator. 10 Hz resolution.
FREQUENCY READOUT	7 digit 10 Hz vacuum fluorescent readout.
FREQUENCY STABILITY	Worst case, 1 PPM per degree C. at 29.999MHz.
FREQUENCY ACCURACY	±100 Hz @ 25° C.
ANTENNA IMPEDANCE	50Ω unbalanced.
POWER REQUIRED	Receive = approx. 1.5A. Transmit = approx. 20 A. @ 13.8 VDC.
CONSTRUCTION	Rigid aluminum chassis. Extruded aluminum front panel. Textured top and bottom, snap up stainless steel bail. Printed circuit boards G-10 epoxy glass.
DIMENSIONS	HWD 5-3/4" x 14-3/4" x 17"—14.6 x 37.4 x 43.2 cm.
NET WEIGHT	16 lbs.—7.25 kg.

TRANSMITTER

MODES	USB, LSB, CW, RTTY (FSK or AFSK), (FM optional).
DC POWER INPUT	Maximum 200 watts @ 14 VDC CW, SSB, (FM). 100% duty cycle for up to 20 minutes. Continuous with auxiliary air cooling of OMNI V amplifier heatsink.
RF POWER OUTPUT	25 to 100 watts adjustable with front panel RF PWR control.
MICROPHONE INPUT	Low impedance. Four pin, front panel connector accepts microphones with 5mV (-62 dB) output. Polarizing voltage is provided for electrets.
T/R SWITCHING	VOX or PTT on SSB. Switchable FAST or SLOW QSK on CW.
CW SIDETONE	Internally generated, adjustable tone and volume independent of AF GAIN control.
SSB GENERATION	9 MHz, 8-pole crystal ladder filter. Balanced modulator.
CARRIER SUPPRESSION	60 dB typical.
UNWANTED SIDEBAND SUPPRESSION	60 dB typical at 1.5 kHz tone.
SPURIOUS OUTPUT	More than 45 dB below peak power output.
METER	Switchable forward power, SWR, collector current, audio processing level.
CW OFFSET	600 Hz automatic.
FSK SHIFT	170 Hz.
SSB MONITOR	External monitor jack output.

RECEIVER

MODES USB, LSB, CW, FSK/AFSK, (FM optional).

SENSITIVITY

FREQUENCY MODE	1.8 - 29.999	
SSB, CW, RTTY	.15 μ V	10 db S/N @ 2.4 kHz
(FM)	.30 μ V	12 db SINAD @ 15 kHz

SELECTIVITY

SELECTIVITY FILTER	-6 dB	-60 dB
STANDARD	2.40 kHz	3.36 kHz
OPTIONAL	1.80 kHz	2.90 kHz
OPTIONAL	.50 kHz	1.40 kHz
OPTIONAL	.25 kHz	.85 kHz
(FM)	15 kHz	30 kHz

ATTENUATOR

Approx. -20 dB for 1.8 to 29.999 MHz.

I-F FREQUENCIES

1st = 9.0 MHz, 2nd = 6.3 MHz, (FM 2nd = 455 kHz).

RX ANTENNA INPUT

Switchable 50 Ω phono jack.

IMAGE REJECTION

> 60 dB.

I-F REJECTION

>60 dB.

NOISE BLANKER

Switchable on/off with adjustable width.

S - METER

Automatically switched on during receive. Calibrated to 50 μ V at S9 .

DYNAMIC RANGE

97 dB typical.

3 rd ORDER ICP

+12 dBm.

SQUELCH SENSITIVITY

FM, CW, SSB, FSK (1.8 - 29.999 MHz) = Less than .6 μ V.

PASS BAND TUNING

\pm 1.2 kHz.

AUDIO OUTPUT

1.5 watts @ 8 Ω with less than 2% distortion.

NOTCH FILTER

250 to 2.2 kHz, 50 dB notch typical.

AUDIO BANDPASS FILTER

4 pole, variable center frequency 220 to 1.7 kHz, 35% bandwidth @ -6 dB. Variable fader control selects filtered or flat audio response.

TONE CONTROL

Variable 15 dB rolloff @ 5 kHz.

CHAPTER 1

INSTALLATION

1-1 INTRODUCTION When setting up the station, provide adequate ventilation for the heat sinks on the transceiver and the power supply. Do not confine the transceiver and power supply to a small volume without forced ventilation to circulate cool air around the heat sinks. Also try to select a location that allows comfortable access to the front panel controls and adequate clearance for rear panel connections.

When operating RTTY, SSTV, FM, or other high-duty modes, it is recommended that a small fan be directed on the heat sink. The sink temperature may reach as high as 200° Fahrenheit, which is still within the rating for the transistors, but certainly hot enough to cause a serious burn if touched.

1-2 FIXED STATION & MOBILE The OMNI V, with conventional antennas, will perform with distinction in any ham shack.

The OMNI V may be used for mobile operation in a car, boat, plane, or other vehicle. It operates directly from a 13.8 volt supply source and is self-contained except for key, microphone, and antenna. It is recommended that the Model 1140 Circuit Breaker be installed in series with the +13.8 volt supply line. The circuit breaker will function as both an external on/off switch and an over-current protection device for the OMNI V.

NOTE: If the battery voltage drops below 12 volts, the OMNI V will not operate properly.

The SWR meter is especially useful in

setting mobile whip antenna lengths to the operating frequency.

WHEN USING AN ALTERNATOR CHARGED BATTERY. DO NOT START AND STOP THE VEHICLE'S ENGINE WITH THE PARAGON TURNED ON. High voltage transients, caused by momentarily open regulator contacts, may cause serious damage to the transceiver circuits.

1-3 POWER SUPPLY Use a 12 to 14 VDC negative ground power source capable of delivering 22 amperes, well regulated. When powering from the Model 961 power supply, interconnect units with the cable attached to the power supply.

When other supplies or a battery are used, pin connections to the power socket are as shown in FIGURE 1-1.

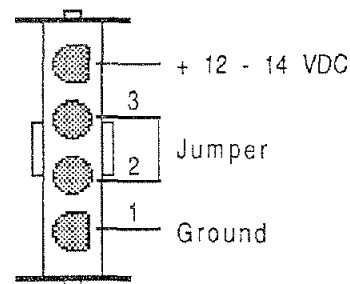

FIGURE 1-1. POWER SUPPLY CONNECTIONS

The front panel POWER switch controls a relay inside the transceiver that switches the high current 13.8 VDC to all circuits except the logic circuits. When using a TEN-TEC

power supply, a wire between pins 2 and 3 enables the primary AC circuit in the power supply when using the supplied cable. The power supply must be turned on BEFORE the OMNI V is turned on.

If making your own power cable, use number 12 or 14 gauge wire for the plus and minus (GND) leads, with the cable length as short as possible for minimum cable loss.

The OMNI V contains a fuse, located on the rear panel. If this fuse needs replacing, be sure to use a 25 Amp. Fast Blow.

If additional protection is desired, a Model 1140 Circuit Breaker may be installed in series with the 13.8 VDC supply line.

1-4 ANTENNAS Any antenna presenting 50 to 75 Ω impedance will load satisfactorily. Random length and balanced antennas will require an antenna tuner. Most popular mobile antennas will operate at their resonant frequency without special matching. When they are used as portable antennas, a good ground system or counterpoise should be provided. The OMNI V is designed for use with an unbalanced feed system.

Although improper antennas will not damage the final output transistors, it is suggested that an SWR of 2 to 1 or less be achieved for maximum performance. In cases where the antenna cannot be matched to a better SWR, the OMNI V can be operated at reduced input power by adjusting the RF PWR control. The collector current (I_c) should be less than 20 Amperes at maximum output power. Be sure to readjust the MIC control after reducing the RF PWR level.

1-5 MICROPHONE For SSB operation, plug a low impedance dynamic or electret microphone into this jack. Amplified microphones can be used if the output level is adjusted to a low enough value to prevent the microphone circuit from overloading. The

OMNI V will work with microphones having an impedance of 200 Ohms to 50k Ohms.

1-6 KEY For CW operation, connect a straight key, bug, or electronic keyer to this jack. When using electronic keyers, they should be configured for positive keying, not "grid block" or negative. If configured for negative keying, no damage will occur, but the keying circuit will not operate.

1-7 GROUND In the interest of personal safety and to reduce the possibility of stray RF pickup on interconnecting cables which may cause parasitic oscillations, all station equipment should be well grounded to earth. It is also important to strap all equipment chassis together with short, heavy leads. The strap between the power supply and the transceiver also serves to reduce the voltage drop on the negative lead caused by wire and connector resistance. In mobile installations, connect a ground strap between the rear panel ground lug and the vehicle chassis.

1-8 BATTERY BACKUP The OMNI V contains a nonvolatile RAM memory system and does not require a battery to retain stored memory information. However, a 3 volt Lithium battery (Mallory DL2032 or equivalent) has been installed to maintain the calendar, 24 hour clock, and microprocessor status registers when power is removed from the OMNI V. This battery is mounted in a holder located on the 81442 Logic Board and should be replaced when the clock fails to keep correct date and time with power removed from the OMNI V. This battery should typically last about two years under normal use.

To replace the 3 volt Lithium battery (Mallory DL2032) proceed as follows:

Refer to PARAGRAPH 5-1.1 for information on removing the top cover. Located in the center of the chassis, on the 81442 Logic Board, is the battery holder. With the POWER switch in the ON position, and the OMNI V operating, remove cable connector (C), located just to the right of the battery holder. Using a small screw driver, carefully slide the old battery to the left and out of the holder. Wipe any finger prints or oil from the new battery with a soft cloth and slide the new battery into the holder, making sure that the positive (+) side is UP. Reconnect cable (C), removed previously. To verify correct operation, turn off the POWER switch and remove the power supply cable. After waiting a minute or two, reconnect the power supply and turn the POWER switch back on. The OMNI V should power up on the same frequency that it was on when you removed power and the clock should not have lost any time. If everything is correct, replace the top cover.

CHAPTER 2

CONDENSED OPERATING INSTRUCTIONS

2-1 INTRODUCTION The following instructions will enable the operator to quickly place the OMNI V into operation. Refer to CHAPTER 3 of this manual for more detailed descriptions of the controls and unique functions of the OMNI V.

Refer to CHAPTER 1 for information on connecting power supply, microphone, antenna, and other accessories.

2-2 SELECTING FREQUENCY There are two ways to change frequency, via the keypad and by using the main tuning knob. With the keypad, the desired band of operation is selected by just pressing the appropriate BAND key. The "down" and "up" arrow keys are used respectively to decrement and increment the operating frequency in either 10 kHz or 30 kHz steps. The step size is set to 30 kHz whenever the FAST tuning function is enabled.

The main tuning knob is used to change the frequency in 10 Hz steps, or in 50 Hz steps if the FAST tuning function is on. When in FM mode, the step sizes are either 100 Hz or 500 Hz. In addition, there is a speed shift circuit which automatically changes the step size to the next larger value if the main tuning knob is turned at a rapid rate. This helps reduce the time required to traverse large frequency changes.

2-3 INITIAL FRONT PANEL SETTINGS

Set the front panel controls as follows:

KEYPAD:

Select Mode, press CW, USB or LSB.

Select VFO A, press A/B until annunciator in display indicates "VFO A".

Select 2.4 kHz Bandwidth, press 2.4 .

AF -----Adjust to suitable audio level
TONE -----Midway
FADE -----Max counter-clockwise
BP -----Max counter-clockwise
PBT-----Midway
NOTCH -----Max counter-clockwise
MIC -----Max counter-clockwise
RF PWR -----Max counter-clockwise
RF -----Max clockwise
SQL -----Max counter-clockwise
METER -----FWD
NB -----OFF
VOX/PTT ----PTT
QSK -----FAST
AGC -----ON & SLOW
ATTN -----OFF
PROC -----OFF

2-4 TRANSMIT

CW ---Press TUNE key on keypad and adjust RF PWR control for desired output power as observed on meter. Press TUNE key again to return to transceive mode.

SSB ---Adjust RF PWR control as described above, then, using PTT, adjust MIC control until ALC LED just lights on voice peaks.

CHAPTER 3

DETAILED OPERATING INSTRUCTIONS

3-1 KEYPAD FUNCTIONS The keypad is used to change Frequency or Band of operation, to select VFO's, Mode, Filter Bandwidth, and to access microprocessor controlled functions. When a key is pressed, a "beep" will be heard from the speaker, indicating key closure. The beep level can be adjusted with the rear panel BEEP/VOICE control.

3-1.1 SELECTING MODE

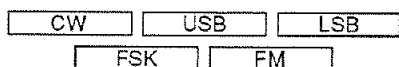

Mode selection on the OMNI V is accomplished by pressing the desired mode key on the keypad. The corresponding LED will light indicating the chosen mode. When selecting the optional FM mode, all of the crystal filter LEDs will be turned off indicating that only the built-in 15 kHz wide FM filter (if installed) is selected. Upon exiting the FM mode the 2.4 kHz filter is selected as the default filter setting.

3-1.2 CRYSTAL FILTER SELECTION



These keys select the desired 6.3 MHz IF bandwidth. A standard 2.4 kHz filter is provided, while the 1.8, .50, and .25 kHz filters are plug-in options. An optional filter (1.8, .50, or .25 kHz) may also be installed in the 9 MHz IF for improved selectivity. This optional filter is selected by the NAR key and

may be used in conjunction with any of the other selected filters. LEDs above the keys indicate the bandwidth selected.

Bandwidth selection is independent of the mode selected except that when FM is selected, all filters are turned off. (See section 3-1.1 above).

The following table lists the recommended filter combinations for various modes of operation.

MODE	6.3 MHz IF	9.0 MHz (NAR) IF
USB	2.4, 1.8	1.8
LSB	2.4, 1.8	1.8
CW	.50, .25	.50
FSK	.50	.50 (RTTY)

TABLE 3-1. IF CRYSTAL FILTERS

3-1.3 TUNE



This key is used to place the transceiver in the transmit mode, or "key down". It is used when adjusting power output, and for system checks and SWR measurements. Pressing this key a second time returns the transceiver to the receive mode.

3-1.4 VOICE/CALENDAR ENABLE



This key is used to activate the Calendar Display Mode or the optional Model 257

Voice Readout. Pressing and releasing this key once will cause the current month and day to be displayed in the following format:

d MM DD

Once the calendar is displayed, the CLR/CLK key may be used to set the calendar as desired. (See section 3-3.3). If the main tuning knob is turned or any other key is pressed, the operating frequency will return to the display.

To activate the Voice Readout, if installed, the VCE key must be pressed twice in rapid succession (within about half a second). If the VCE key is held in after the voice has been activated, the Voice Readout will go into a shortened annunciation mode in which only the last five digits of the displayed frequency will be voiced.

3-1.5 REV REV

Whenever the SPLIT function is enabled, pressing this key reverses the transmit and receive frequencies allowing the operator to listen to the frequency that he is transmitting on. This is a momentary function and the transceiver will return to the previous receive frequency when the key is released. This key has no effect when operating in simplex.

3-1.6 VFO SELECTION / OFFSET TUNING A=B A/B

These keys control the operation of the two VFOs. The A/B key toggles between VFO A & VFO B with the annunciators in the display indicating the selected VFO. When the A=B key is pressed, the band, frequency, mode, and crystal filter selection of the selected (and displayed) VFO is placed in the other undisplayed VFO.

SPLIT

The SPLIT key allows the receive and transmit frequencies to be assigned to each VFO. An annunciator in the display indicates that this function is enabled.

To receive on VFO A and transmit on VFO B, select VFO B with the A / B key and select the desired transmit frequency, then select VFO A and select the desired receive

frequency. Then press the SPLIT key.

To transmit on VFO A and receive on VFO B, select VFO A and the transmit frequency. Select VFO B and the receive frequency, then press the SPLIT key.

Pressing the SPLIT key a second time disables this function. NOTE: When tuning with the SPLIT mode on, only the displayed VFO is changed.

OFFSET TUNING is most easily achieved by always operating in the "SPLIT" mode. When you tune in a station that you want to work "simplex", press A=B and call. If "OFFSET" is desirable, press A=B to net the VFOs to the same frequency, mode and filter. Hold down the "REVERSE" button, which switches the receiver to the opposite VFO, and tune up "X" kHz, find the station being worked or find a hole in the pile-up. Then release the "REV" button and you are back listening to the "target". Tuning the receiver has no effect on the transmit frequency selected and vice versa. There are three advantages to this system. One, it uses the fewest button and knob functions. Two, all frequency tuning is done by the main tuning knob and three, you always listen to the transmit frequency as you chose the spot.

3-1.7 TUNING RATES

FAST

The FAST key, with LED indicator, selects the tuning rate and resolution of the main tuning knob according to the following table.

	Normal	Normal Shifted
CW/USB/LSB/FSK	10 Hz	50 Hz
FM	100 Hz	500 Hz
	Fast	Fast Shifted
CW/USB/LSB/FSK	50 Hz	100 Hz
FM	500 Hz	500 Hz

TABLE 3-2. TUNING RATES

In addition, the tuning knob has a speed shift feature which increases the tuning rate automatically when the knob is spun at a fast rate.

3-1.8 BAND SELECTION

160	20	10A
80	17	10B
40	15	10C
30	12	10D

These keys are used to instantly select the desired ham band for operation. When going from one band to another, the operating frequency will be automatically located at the same position relative to each band edge. For example, if you are initially on the 40 meter band at 7.040 MHz, pressing the 20 meter band key will place the operating frequency at 14.040 MHz, up 40 kHz from the lower band edge. The 10 meter band is broken down into four 500 kHz wide segments selected by the 10A, 10B, 10C, or 10D keys.

When operating on any band except 10 meters, you will be able to tune a 500 kHz segment plus a 30 kHz section on each end for MARS, etc. On the 10 meter bands, you can continuously tune all four sections without pressing any of the Band keys. For example, if you are on the 10A band and tune upwards past 28.530 MHz, band 10B will be automatically selected allowing you to continue tuning through the next 500 kHz segment. This process is repeated for the 10B and 10C bands. The 10 meter band segments are also automatically selected when tuning down in frequency beyond the normal band margin.

3-1.9 DOWN / UP



These keys are used to quickly move up or down in either 10 kHz or 30 kHz steps. When the FAST tuning function is Off, the step size is 10 kHz. When the FAST tuning is On, the step size is 30 kHz.

When in the calendar or clock setting mode, these keys are used to decrement or increment the selected clock register (hours, minutes, month, or day).

3-2 MEMORIES

The OMNI V has 25 memory locations which may be used to store favorite or often used frequencies. These memories are located in a nonvolatile RAM and will be retained even if all power is removed from the OMNI V. Each memory stores band, frequency, mode, and filter selected. There is also a scratch pad memory designed for rapid store and recall of temporary band, frequency, mode, and filter settings.

3-2.1 SCRATCH PAD MEMORY

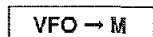

The scratch pad memory can be used to temporarily store and recall a single frequency without affecting the main memory locations. To save the current band, frequency, mode and filter information in the scratch pad, simply press and release the VFO->M key once. To recall the scratch pad memory, first make sure that the Memory Tune function (MT) is turned off, then press the M-> VFO key once.

3-2.2 MEMORY STORE

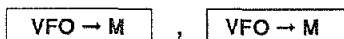

To store information in RAM memory, first make sure that the band, frequency, mode, and filter selections are correct. Next, press and release the VFO->M key twice in rapid succession (within about half a second). The current settings will be automatically stored in the next available memory location. If all memory locations are full, the right-most decimal point in the frequency display will be turned on. If this happens, you must follow the MEMORY CLEAR procedure described in section 3-2.5 to clear out one of the existing memories before you can store any new frequencies.

3-2.3 MEMORY TUNE



MT

When this function is turned on, as indicated by the LED above the key, the main tuning knob will no longer tune the VFO but will tune through all of the programmed memories. When tuning through the memories, only the frequency display will change. The mode, filter settings, and synthesizer operating frequency will remain unchanged. Thus, the Memory Tune function allows you to scroll through your memories without affecting the settings of the transceiver. **The frequency that you are listening to will not change when tuning through the memories.** When you find a memory that you wish to recall, simply press the M→ VFO key and all memory information will be transferred to the transceiver mode, filter and synthesizer circuits.

Note: When first turned on, the MT function will display the last memory location that was accessed either by a store or a recall operation.

3-2.4 MEMORY RECALL

M → VFO

If the Memory Tune (MT) function and LED is off, pressing this key will recall the scratch pad memory settings. If the Memory Tune function is turned on, pressing this key will recall the currently displayed memory information (including mode, filters, and synthesizer frequency).

3-2.5 MEMORY CLEAR

CLR/CLK

To clear a single selected memory location, first activate the Memory Tune (MT) function and tune through the memories until you locate the one that you wish to clear, then press

the CLR/CLK key once. This will clear the currently displayed memory location, returning it to an unprogrammed state.

If you wish to clear all memories, turn off the OMNI V POWER switch, then while holding in the CLR/CLK key, turn the POWER switch on. Upon releasing the CLR/CLK key, the frequency display will come on and all memory locations in the nonvolatile RAM will have been cleared.

3-3 CLOCK-CALENDAR FUNCTIONS

The OMNI V has a built-in 24 hour, crystal controlled clock and calendar circuit. As long as power is supplied by the power supply or the internal 3 volt Lithium battery, the clock will keep accurate time. The procedures for accessing and setting the clock and date functions are described below.

3-3.1 CLOCK DISPLAY

CLR/CLK

To display the current time, first make sure that the Memory Tune (MT) function is turned off. Press and release the CLR/CLK key once and the frequency display will be replaced by the current time in the following format:

HH MM

Turning the main tuning knob or pressing any other key (except CLR/CLK) will cause the operating frequency to return to the display.

3-3.2 CLOCK SET

CLR/CLK

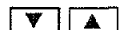

CLR/CLK

To set the time in the 24 hour clock, first tune the OMNI V to the WWV time signal at 10.000 MHz. Then recall the current time as described above in section 3-3.1. Press the CLR/CLK key again and only the hours will be displayed.

Use the UP and DOWN arrow keys to set the hours to the correct value. Next, press the CLR/CLK key again. Now only the minutes will be shown. Using the arrow keys adjust the minutes to the correct time. Finally, when the WWV marker tone sounds, press the CLR/CLK key again and the display will return to your operating frequency and the clock will be started. To verify that the time is correct, simply recall the time as described in section 3-3.1.

3-3.3 DATE SET

VCE , CLR/CLK , ▼ ▲ , CLR/CLK

To set the date, first recall the current date using the VCE key as described in section 3-1.4. Press the CLR/CLK key and only the month will be displayed. Use the UP and DOWN arrow keys to set the month to the correct value. Next, press the CLR/CLK key again and note that only the day is displayed. Use the arrow keys to adjust the day to the desired value. Finally, press the CLR/CLK key again and the display will return to your operating frequency.

3-3.4 WWV REMINDER At sixteen minutes past each hour a short beep will be heard. This tone is designed to remind the operator that WWV is now transmitting propagation information which is useful when working DX.

3-3.5 SYSTEM RESET SWITCH The RESET switch is accessible through a hole located on the right side of the OMNI V. If the OMNI V ever malfunctions and the keypad and/or tuning knob no longer operate properly, first try turning the POWER switch off and back on. If this does not help, pressing the RESET switch will usually correct the problem. **NOTE: This will clear the clock and date information.**

3-4 FRONT PANEL FUNCTIONS The following sections describe the front panel displays and the controls which are not located on the keypad. Refer to FIGURE 3-2 to help locate each control.

3-4.1 DISPLAY AREA The vacuum fluorescent display shows the frequency, date, or time. The three annunciators to the left of the frequency readout show the active VFO, and whether the SPLIT mode is enabled.

3-4.2 AF GAIN / TONE The AF GAIN control varies the audio output of the transceiver. The TONE control is a low pass type with a rolloff of approximately 15 dB at 5 kHz.

3-4.3 METER & SWITCH In receive mode the meter will automatically read S units when the meter switch is in any position. The S meter will be accurate only when the RF control is fully clockwise. The meter is factory calibrated for a reading of S9 at 50 μ V when operating at 14 MHz. The S meter calibration can be changed by adjusting R45 located on the 81462 IF/AF Board. Use R43 to adjust the zero offset point with no signal applied to the OMNI V. For further information, see section 6-7.

When transmitting, the meter indicates the following:

IC position measures the current drawn by the final amplifier module. Use the scale marked 0 to 20 amperes.

SWR position provides a reading of power reflected from the antenna. When the forward power is 100 watts, the standing wave ratio can be read from the scale marked SWR.

FWD position measures forward power to the antenna. Use the FWD scale marked 0 to 100 watts.

To determine SWR, place meter switch in FWD position, press TUNE and adjust RF PWR control for a reading of 100 watts. Then switch the meter switch to REF

and use the scale marked SWR. Press the TUNE key again to return to transceive mode.

PROCESS position displays the level of compression applied to the MIC input when the PROCess control is turned on.

3-4.4 NOISE BLANKER The N.B. switch turns on the blanker circuit. The WIDTH control varies the blanking pulse width.

3-4.5 ATTENUATOR To reduce susceptibility to receiver overload in the presence of extremely strong signals, the ATTN switch removes the front end RF amplifier from the receiver circuitry. The effect is a 20 dB reduction in signal level to the first mixer but with more dynamic range and greater sensitivity than would be the case with a simple attenuator. The LED below the switch indicates that the attenuator has been selected.

3-4.6 BPF / FADE This control fades from normally flat audio response to a bandpass filter variable from 220 to 1700 Hz with the BPF control. Various amounts of bandpass effect can be chosen by the degree of clockwise rotation. The filter width is 35% of the selected center frequency at the -6 dB points.

3-4.7 PBT / NOTCH The PBT control adjusts the position of the PBT IF crystal filter in relation to the fixed second IF filter. When the selected filter is wide, i.e. 2.4 or 1.8 kHz, the PBT control essentially becomes a variable bandwidth control. Counter-clockwise rotation shifts the passband towards the low side of the signal when in USB mode, clockwise rotation shifts the passband toward the high side of the signal. When in LSB mode, the above directions are reversed.

The PBT circuit in the OMNI V produces the effect of varying the frequency response of signals passing through the narrow filter, which enables you to separate signals which are close together. On FSK (RTTY) it can

place the narrow filter to pass only the 2295 and 2125 Hz tones for superior rejection of adjacent signals. The PBT has no effect on the transmitter frequency or bandwidth.

The NOTCH control adjusts the center frequency of the audio notch across the passband. The notch depth is at least 40 dB and will reduce carrier interference by this amount or more. To use the NOTCH, rotate the control slowly until the unwanted signal is reduced. The notch circuit is effectively removed by turning the control fully counter-clockwise.

3-4.8 MIC / RFPWR The RFPWR control varies the amount of power output for all modes. This allows you to set your output power to any value from 25 to 100 Watts. The MIC control varies the amount of audio applied to the transmit balanced modulator.

To set these controls, place the METER switch in the FWD power position and place the transceiver in transmit using the TUNE function. Advance the RF PWR control to the desired power level. The CW level is now set. For SSB operation, continue by placing the transceiver in either the USB or LSB mode and while speaking into the microphone in a normal voice, advance the MIC control until the ALC LED lights on voice peaks. NOTE: The ALC LED will light at all RF PWR settings when operating in CW or TUNE modes.

Increasing the MIC setting over that required to just light the ALC LED will not result in any appreciable increase in power out. However, overdrive will produce SSB, AFSK, or SSTV distortion products.

The OMNI V uses a "current-limit" protection system where the drive level is automatically reduced to prevent the final transistors from drawing more than 20 amperes. If full power output can not be obtained, it is an indication that the antenna is not presenting a 50 Ω impedance. Refer to PARAGRAPH 4-1.4 for more information.

3-4.9 PROC The PROCess switch and control activates the speech processor and determines the processing level. The processor increases the average speech power and allows a greater range of voice levels to attain peak ALC level. An LED below the switch indicates when the processor has been selected.

The processing level will affect the MIC control to some extent. To set the processor, turn it off and adjust the RF PWR and MIC as described above. Turn the PROCess switch on and advance the control until the meter needle moves into the center of the black band (on the PROC scale) on voice peaks. More processing is available by further clockwise rotation of the control, but the MIC control must be reduced to keep the ALC action constant.

Severe distortion, objectionable background noise, and transmitted splatter will occur if the MIC control is not adjusted so that the ALC LED just lights on voice peaks. The processed audio may be monitored to prevent this distortion by using the MONITOR control on the rear panel. The use of headphones is recommended to prevent feedback from the speaker. See PARAGRAPH 3-5.7.

3-4.10 RF / SQL The RF gain control varies the gain of the I-F stages. The AGC is dependent on the setting of this control and therefore the S meter is calibrated only when the RF gain control is fully clockwise.

The SQL control sets the squelch threshold level. The squelch level is determined by the AGC circuits. To adjust the squelch, rotate the control clockwise until the received audio becomes quiet. To turn the squelch function off, rotate the control fully counter-clockwise.

3-4.11 AGC FAST / SLOW & ON / OFF These switches control the automatic gain control (AGC) system. In the FAST position, the recovery time of the AGC system is approximately .2 seconds and in the SLOW position approximately 2 seconds.

The ON/OFF switch defeats the AGC system. When the AGC is turned OFF, the IF gain is controlled by the RF gain control and the S meter is inoperative.

It is sometimes useful, when extreme QRM is present, to turn the AGC off and control the audio volume with the RF gain control.

3-4.12 VOX / PTT This switch selects either the internal VOX (voice operated transmit) or manual PTT (push-to-talk) circuitry.

3-4.13 QSK FAST / SLOW The QSK switch controls the recovery time of the receiver after transmitting. Place in the FAST position for cw full break-in.

3-4.14 PWR This switch controls the main power to the transceiver via an internal relay which switches the high current 13.8 VDC. Power is connected to the logic circuits at all times.

3-4.15 PHONES This jack is designed to be used with a standard 1/4" plug. Either stereo or monaural headphones with an impedance of 4 to 16 ohms may be used. Both the internal speaker and external speaker jacks are disabled when headphones are plugged in. The AF OUT jack is not affected by using the PHONES jack.

3-4.16 MIC The microphone circuit has been designed for low impedance microphones with a minimum 5 mV output. Transistorized microphones may also be used, providing their output level is adjusted so that the input stages are not overdriven. The cable, which preferably should provide shielding for all leads, is terminated with a standard 4 pin microphone plug. Failure to shield both microphone and PTT leads may result in RF getting into the audio circuits. Connections to the plug are as shown on the next page in FIGURE 3-1.

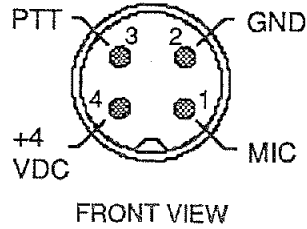

FIGURE 3-1. MIC CONNECTIONS

SPECIAL NOTES

FSK OPERATION

To optimize receiver performance on the FSK modes, it is necessary to offset the Pass Band Tuning to approximately 3 o'clock on the PBT control. This is especially important if you are using the 500 Hz filter in the 6.3 MHz I-F. This is necessary due to the 2125/2295 Hz tones normally used on the FSK modes. Fine adjustment of the PBT control will optimize receiver performance regardless of the tone frequencies in use. For shifts wider than 225 Hz, the 1.8 or 2.4 KHz filter should be used.

The Model 216, 9MHz I-F filter is a special filter designed for FSK use. Since there is no PBT control in the 9 MHz I-F, this filter must be used to optimize FSK performance. The standard Model 217, 500 Hz cw 9 MHz filter, will not work on FSK because it is optimized for 600 Hz tones.

NOTE; WHEN YOU CHANGE MODES TO CW OR SSB, DO NOT NEGLECT TO CENTER THE PBT CONTROL TO 12 O'CLOCK.

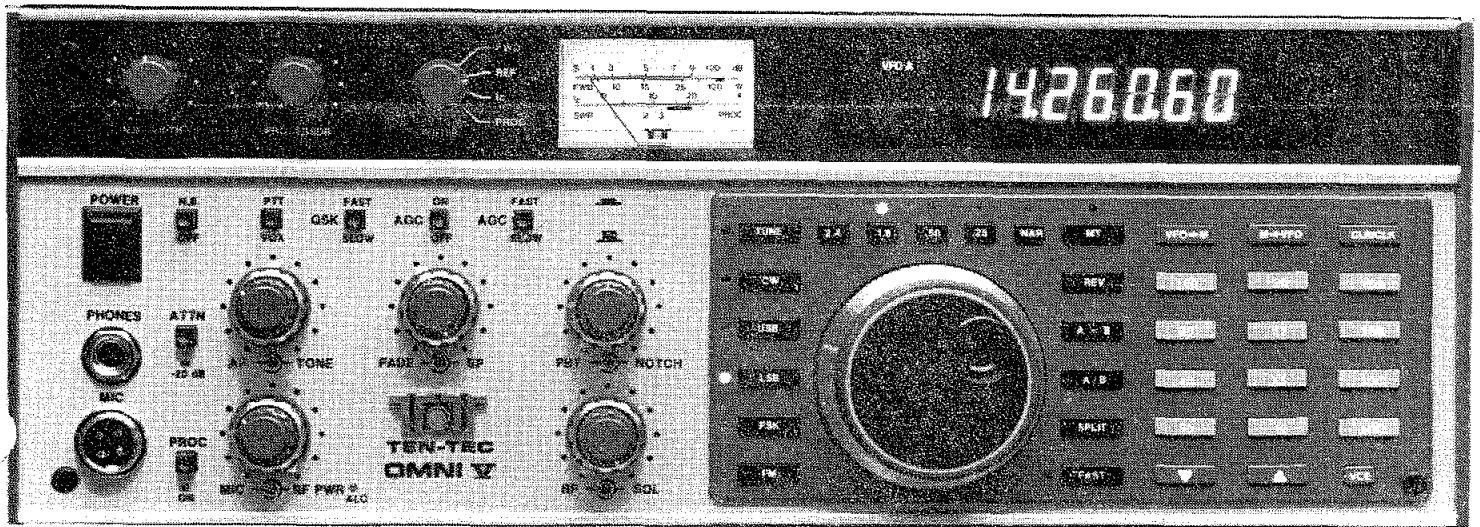

FIGURE 3-2. MODEL 562 FRONT PANEL

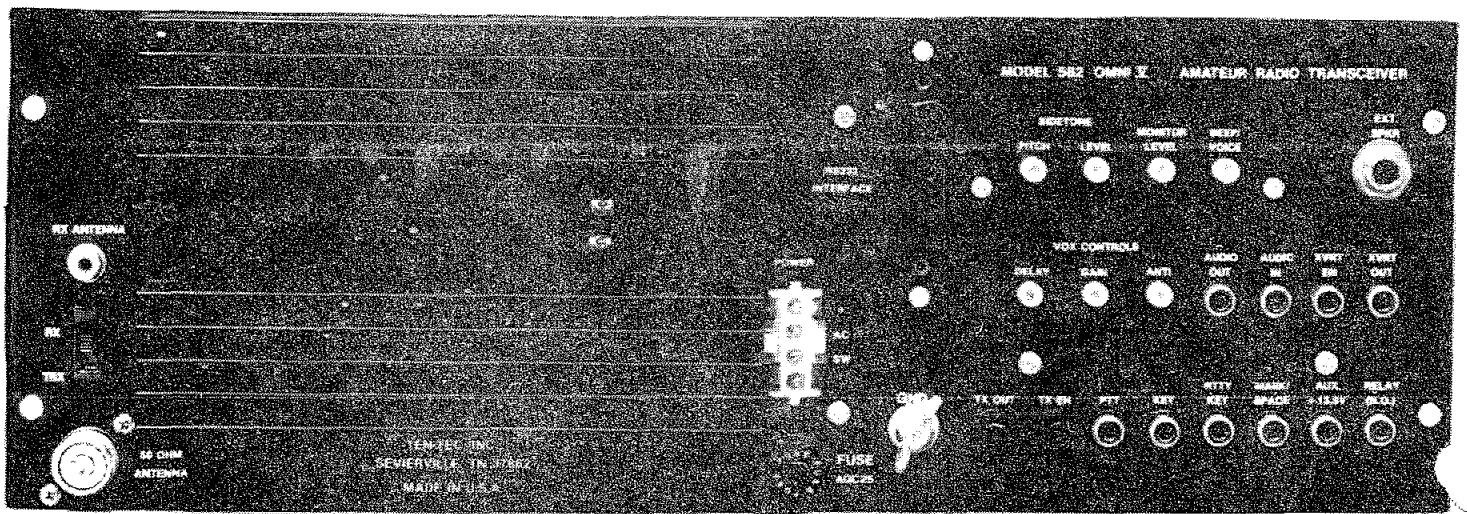

FIGURE 3-3. MODEL 562 REAR PANEL

3-5 REAR PANEL FUNCTIONS The following sections describe the rear panel connectors and controls. Refer to FIGURE 3-3 for the location of each connector or control.

3-5.1 POWER SOCKET This connector is used for the main DC power to the transceiver and for switching the power supply output on and off. Reverse polarity protection is provided via an internal reverse-biased diode and 25 ampere fast blow fuse.

Refer to PARAGRAPH 1-3 for connection details.

3-5.2 GROUNDPOST Used for the primary transceiver ground. To prevent personal injury, interference and other ground related problems, connect this terminal to a good earth ground using heavy gauge copper braid or wire and make the connection as short as possible.

3-5.3 FUSE This fuse is a 25 Ampere Fast Blow and is used in conjunction with an internal reverse-biased diode to provide reverse polarity and over-current protection.

3-5.4 ANTENNA This connector mates with the standard PL-259 plug for 50Ω coaxial antenna or external linear amplifier connections.

3-5.5 RECEIVE ANTENNA This jack provides a connection directly to the receiver front end at all times. When the RX-TRX switch is in the RX position, the SO-239 Antenna connector is disconnected from the receiver, and a receive-only antenna may be connected to the RX ANTENNA jack. This also permits use of a secondary receiver when the switch is placed in the TRX position and the secondary receiver antenna input is connected to the jack. The transmitter is connected to the SO-239 connector in both the RX and TRX positions.

3-5.6 CW SIDETONE The LEVEL and PITCH controls adjust the internally generated sidetone during cw transmit.

3-5.7 VOX CONTROLS The rear panel GAIN, DELAY, and ANTI VOX controls can be adjusted to suit the individual operator's needs. To adjust, proceed as follows:

- 1) Adjust the front panel AF GAIN control to a comfortable level.
- 2) While speaking into the mic at normal level, adjust the GAIN for reliable VOX action.
- 3) Adjust the DELAY so that T/R switching does not occur between words when speaking into the microphone.
- 4) Set the ANTI VOX to the point where receiver audio does not trip the VOX circuit at moderate volumes.

3-5.8 SSB MONITOR LEVEL This control permits monitoring the SSB transmit audio thru the audio amplifier circuit of the transceiver. It is useful when adjusting the internal speech processor so that the processed audio has not been increased to the point where severe distortion occurs. Also, it is useful for checking AFSK and SSTV signals. Headphone use is recommended when using the SSB Monitor function to prevent feedback from speaker to microphone. During normal SSB operation this control should be left in the full counter-clockwise position.

3-5.9 BEEP/VOICE This control is used to set the level of the keypad "beep" and optional voice outputs. You can turn it off by rotating the control fully counter-clockwise.

3-5.10 KEY The transmitter can be keyed by a ground connection to the high impedance KEY input when the CW mode is selected. This line is compatible with open collector (positive) keyer outputs as well as bugs and straight keys. When the key is closed the

antenna is electronically disconnected from the receiver and the receiver stages are disabled.

3-5.11 XVRT EN / XVRT OUT These jacks can be used in conjunction with an external transverter for VHF/UHF operation. A closure to ground on the XVRT ENable jack switches the low level transmit carrier (approx. 0 dBm or 224 mV @ 50 Ω) to the rear panel XVRT OUT jack and disables the OMNI V final output amplifier.

The transverter receive output can be connected to the Receive Antenna jack described above.

3-5.12 AF OUT This jack provides a line level receiver audio output for use with an external RTTY demodulator or tape recorder. Level is not affected by the front panel AF gain control.

3-5.13 TX EN / TX OUT The TX ENable/ TX OUT jacks provide a keying loop for use with some types of external linear amplifiers. For normal operation these jacks are jumpered together. For more information refer to FIGURE 5-7 which shows the connections required for use with the TITAN amplifier.

TX ENable: A closure to ground places the transceiver into transmit mode regardless of mode selected.

TX OUT: Provides a closure to ground thru an open collector transistor to ground whenever the OMNI V is in transmit mode.

3-5.14 PTT This jack is in parallel with the push-to-talk line on the microphone front panel jack. It may be used with an external transmit/receive station switch, foot switch, etc. A closure to ground places the transceiver in transmit mode only in USB, LSB and FM modes. It is inoperative in CW mode.

3-5.15 AUX 13.8 This jack provides unfused 13.8 VDC @ 2 amperes maximum and may be used to power external equipment such as an

electronic keyer. The AC power supply used to power the OMNI V must have enough current capacity to power both the transceiver and any accessories connected to the AUX 13.8 jack.

3-5.16 AUDIO IN Low level audio signals (500mV max.) such as an AFSK input, phone patch, etc. can be mixed together into the mic channel through this input. Typical input impedance is 2.2 K Ω . *Caution: Some AFSK equipment will output a signal even when not activated. If this signal is left connected to the AUDIO IN jack, it can interfere with normal SSB and VOX operation.*

3-5.17 EXT. SPKR A standard 1/4" phone jack for connecting an external speaker. The internal speaker is disconnected whenever this jack is used. Any 4 to 16 ohm speaker may be used.

3-5.18 RELAY This jack provides a normally open relay contact which switches to ground during transmit. Since one side of this connector is grounded, **DO NOT** use it to switch AC lines.

When operating cw, a drop-out delay is incorporated in the relay circuit. The delay time is factory set to an average value and may be adjusted via a small trimmer potentiometer on the Control Board, located under the cover on the bottom side of the transceiver. There is no delay in the other modes. Setting this control for a longer delay will help reduce the noise caused by the relay during CW keying.

3-5.19 RTTY KEY This jack is in parallel with the KEY jack and can be used to control the OMNI V during RTTY operation. A closure to ground places the transceiver in transmit mode.

3-5.20 MARK / SPACE This is the input for RTTY keying. The RTTY MARK level can be 0 to -15 Vdc. The SPACE should be between +2.5 Vdc and +15 Vdc.

CHAPTER 4

OPERATING HINTS

4-1 INTRODUCTION The following paragraphs provide additional useful information for getting the best performance out of your OMNI V. Also included is TABLE 4-1, which provides trouble-shooting information if you should ever have a problem.

4-1.1 CW In the CW mode, the indicated frequency is the transmitted frequency. To accurately read an incoming signal, therefore, it is necessary to peak it on the S meter.

When operating cw, the actual received frequency is 600 Hz lower than the displayed transmit frequency. This is due to the BFO shift necessary to bring the oscillator into the filter passband. To accurately determine the received frequency, subtract 600 Hz from the transmit frequency, or if SPLIT VFO's are used, subtract 600 Hz from the programmed transmit frequency.

4-1.2 FM The OMNI V will operate transceive ± 5 kHz deviation FM with the optional Model 256 FM Adaptor.

The PBT, Crystal Filter selection keys, and Noise Blanker switches do not function in this mode. The AGC switch must be on to enable the S-meter and squelch.

If split Rx / Tx is desired when operating thru repeaters, program the transmit and receive frequencies in VFO A and VFO B.

The MIC control has no effect in the FM mode and deviation (normally preset for the Model 705 microphone) is adjusted on the FM Adapter board.

4-1.3 FSK (RTTY) To enable the FSK mode, press the FSK key.

Required external equipment are a teletypewriter or keyboard and a demodulator (terminal unit) designed for 170 Hz shift with 2125/2295 Hz tones. Audio for the demodulator may be taken from the AF OUT jack on the rear panel. The PBT control may be used to selectively filter out everything but the 2125/2295 Hz tones.

The FSK keying should be connected to the MARK / SPACE jack (MARK: 0 to -15Vdc, SPACE: +2.5 to +15 Vdc) and a separate T/R function is provided on the RTTY KEY jack (ground to transmit).

AFSK operation is also possible by using the AUDIO IN jack on the rear panel or the MIC connector on the front panel.

4-1.4 PROTECTIVE CIRCUITRY & ALC ALC serves three major functions: assures maximum power from the transmitter without critical adjustment of the input drive, prevents the amplifier from being overdriven into the non-linear, distortion-producing area, and serves as a power limiting device which protects the output transistors. It does the first two very well, but the third only partially. To protect the system, the OMNI V uses current limiting circuitry which automatically reduces the drive level if the current demand is greater than 20 amperes. As an extra measure of protection, the TEN-TEC Model 961 power supply (or the Model 1140 magnetic circuit breaker) has a trip-out feature that prevents currents in excess of 20 amperes.

If the ALC LED lights at power outputs less than 100W, this is an indication that the current limiting circuits are reducing drive. This also occurs if the RF PWR control is turned down. Although the OMNI V will operate satisfactorily under these conditions, an improvement in the antenna system or matching network will provide maximum efficiency.

4-1.5 SOLID-STATE POWER AMPLIFIERS

Although transistors and vacuum tubes both can be made to amplify RF power, there are some fundamental differences in how this is accomplished. A better understanding will aid in recognizing correct or incorrect performance.

Misconceptions sometimes arise from incomplete knowledge which results in erroneous conclusions being drawn that the equipment is faulty, erratic, or not performing to specifications. The purpose of the following information is to brief you on solid-state "no-tune" RF amplifiers so that you can knowledgeably approach and correct any apparent improper performance characteristic.

4-1.6 BROADBAND vs RESONANT TANKS

Almost all tube circuits use resonant tanks in the plate circuit. The OMNI V uses a broadband system. In class AB operation, these two approaches act similarly without drive being applied. The idle current is relatively low and within the device dissipation rating, even with load impedance variations from open to short circuit.

However, with drive applied, the two act very differently. In the case of tubes, the dissipation within the tube depends on both the tuning of the tank and the load applied. If the tank is resonated and the load is very light, the internal power dissipated is quite small as indicated by the null which reduces plate current almost to the level with no drive. Out of resonance, the plate current, and hence dissipation, increases rapidly and may damage the

tube from overheating. In resonance, as the load is increased, the null becomes more shallow at a higher plate current as a result of the power being delivered to the load. As the tank is tuned to resonance, the load impedance, which is usually on the order of 50Ω , is transformed to a relatively high impedance of several thousand ohms to match the plate circuit impedance. Small load reactive components, either capacitive or inductive, can usually be balanced out in the tank resonating function.

With transistors, drive applied and no load, there is no resonant high impedance to limit the collector current, and so power is poured into the circuit (much as the out-of-resonance tank condition). Since there is no load power, all has to be dissipated in the transistor. So even with no load, the ALC LED may light as the current limiting circuitry is automatically reducing drive level, or the power supply circuit breaker may trip. The broad-band transformer system used with transistors transforms the 50Ω load impedance not higher, but much lower (on the order of 4 or 5 Ω) to match the transistor output impedance. Since this transformation is fixed in design, any reactive component in the load impedance is applied in a transformed way to the collector circuit. Certain reactances at this point, especially inductive, give rise to parasitic oscillation. To correct for this, the antenna impedance should be changed to remove this reactance, or a matching network should be inserted between the antenna and transceiver. It is important to remember that any antenna changes its impedance with frequency, so that one that resonates well at one end of the band may well cause oscillations to activate the current limiting or trip the circuit breaker on the other end of the band. If entire band operation is desired, especially on the lower bands, an adjustable matching network would be the better choice, rather than to try to make the antenna behave over the entire band on a cut-and-try basis.

A final point to bring out regarding broadband vs tank systems is that there is a limit to the amount of current that you can draw from an emitting filament, and this saturation current will limit the amount of power drawn from the supply. In the case of transistors, where the collector internal impedance is only a fraction of an ohm, extremely high currents can be demanded of the power supply, especially with mismatched loads well below 50 ohms. A fuse is provided in the OMNI V for protection when operating from a power source that is not limited.

4-1.7 SWR - Two Kinds The standing wave ratio is direct measure of the ratio between two impedances, i.e. a SWR of 3 to 1 indicates that one impedance is three times the other. Therefore, the unknown impedance can be either three times as large or three times as small as the known one. If the desired impedance that the transceiver wants to see is 50Ω , an SWR of 3 to 1 on the line may mean a load impedance of either 150Ω or one of 17Ω . If it is 150Ω , the transmitter will act differently than if it is 17Ω . In the first case, the power demanded from the power supply will be much lower, and not large enough to trip the circuit breaker. In the second case, even though the SWR reads the same, the breaker may repeatedly trip out. The SWR reading gives no indication of reactive components, nor can it separate the resistive from the reactive components. It is calibrated with a pure resistive load and therefore has its greatest accuracy with pure resistive loads. The SWR bridge should be used only as an indicator when attempting to adjust antenna systems to a pure 50Ω resistive impedance at the transmitter output point.

4-1.8 EFFICIENCY Since transistor amplifiers have a very low value of output impedance, they act more or less as a constant voltage source. That is, the RF output voltage

tends to remain at a fixed value regardless of the load impedance. Hence, the output power will vary depending on the value of the load, and increases as the load impedance goes down. It can be seen that a 3 to 1 SWR on the low side of 50Ω will ask the amplifier to deliver much more power than a 3 to 1 SWR on the high side. Since the amplifier does have a finite value of output impedance, the amount of power delivered to the load with efficiency will change with load. Unless the load is near the design value, the transistors will heat up unnecessarily without delivering any more power to the antenna.

Recommended Reading: ARRL HANDBOOK

IF YOU HAVE TROUBLE

If the transceiver should fail to operate as normal, use the following chart as an aid in determining the problem. Often the cause of the problem is an overlooked switch/control or a mistake in entering information into the keypad.

SYMPTOM	POSSIBLE CAUSE
Transceiver dead, no meter illumination, no display.	Check power switch on transceiver and power supply. Check power cable. Check supply for correct voltage.
Receiver dead, meter and display on.	<u>Check Squelch</u> , and AF gain controls. Check Phones and Ext. Spkr jacks. Check Crystal Filter keys for selection of bandwidth with option not installed. Check if FM mode selected without option installed. Check RX/TRX switch.
Transmitter dead, meter and display on.	Check TX EN/TX OUT jumper plug on rear panel. Check microphone, PTT switch, and microphone cable & connector Check if FM mode selected without option installed.
Received signal strength low.	Check ATTN switch and RF gain control.
Main tuning knob will not change frequency.	Check that MT LED is turned off.
Main tuning knob will not change frequency, keypad will not respond to input.	Microprocessor may be in process of a selected function routine. Memory Tune mode is selected with no memory locations programmed. Turn OMNI V POWER switch off and back on.
No readout, audio present. Readout present, cannot enter commands.	Microprocessor may be locked up due to an incorrect keyboard entry or a power supply noise spike. Turn the POWER switch on the OMNI V off and then back on. If this does not clear the problem, the microprocessor will have to be reset. Press the RESET button located on the lower right side of the OMNIV. <u>NOTE: PRESSING THE RESET SWITCH WILL RESET THE TIME AND DATE.</u> Use this approach only as a last resort.
When in SSB mode, transmitted audio is heard in speaker or headphones. (Talk-through)	Check SSB MONITOR LEVEL control on rear panel.
Unable to turn on SPLIT function.	The modes selected for VFO A and VFO B are not the same. Change the mode of one of the VFOs or press A=B to make all information (frequency, mode, and filter) equal in both VFOs.
Clock and Calendar contain erroneous readings after power has been removed from OMNI V.	Replace 3 volt Lithium backup battery. See section 1-8.
Phantom audio "Beep" tones heard at unexpected times, not related to key pad entries.	<u>This is normal.</u> A single "Beep" tone is heard at sixteen minutes past each hour as a reminder that WWV propagation reports are now being transmitted. This information is very useful for DX operation.

TABLE 4-1. TROUBLE SHOOTING CHART

CHAPTER 5

OPTIONS INSTALLATION

5-1 INTRODUCTION The following paragraphs describe how to remove the top and bottom covers of the OMNI V and the basic steps required to install the various optional accessories available for use in the OMNI V. Additional instructions and information may be supplied with each of the options.

5-1.1 REMOVAL OF TOP & BOTTOM COVERS To remove the top cover, remove the upper two of the four large Phillips screws located on each side. Slide the top back and out from under the rear lip of the extruded front panel. *Caution:* Speaker wires will limit removal of the top cover. Unplug the speaker connector before completely removing the top cover.

To remove the bottom cover, remove the lower two large Phillips screws located on each side. With the transceiver upside down and the front panel facing forward, slide the bottom cover back and out from underneath the rear lip of the extruded front panel.

5-1.2 "MASS TERM" CONNECTORS

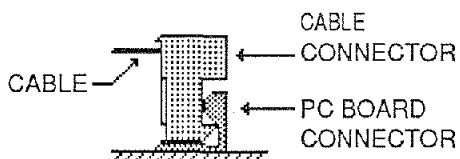

FIGURE 5-1. MASS TERM CONNECTOR

Some of the options require attachment of cables to the options pc board. The "mass term" type connectors have an identification

number on the cable connector which matches the same number printed on the top of the pc board. The polarity of the connectors is as shown in the diagram.

5-1.3 CRYSTAL FILTERS There are four optional crystal filters which may be installed in the OMNI V. The Model 288 (1.8 kHz), Model 285 (.5 kHz), and Model 282 (.25 kHz) filters may be installed as shown in FIGURE 5-2. These optional filters plug into the 81460 Pass Band Tuning Board located on the bottom side of the transceiver. The inputs and outputs of these boards are the same and therefore they may be installed in either direction.

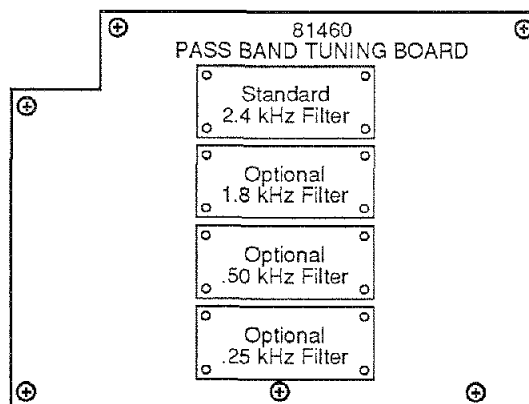

FIGURE 5-2. PBT CRYSTAL FILTER LOCATIONS

A fourth optional crystal filter [Model 218 (1.8 kHz), Model 217 (.5 kHz), or Model 219 (.25 kHz)] may be installed in the 81410 9MHz IF Board as shown in FIGURE 5-3. This filter is selected by pressing the NAR key on the front panel keypad.

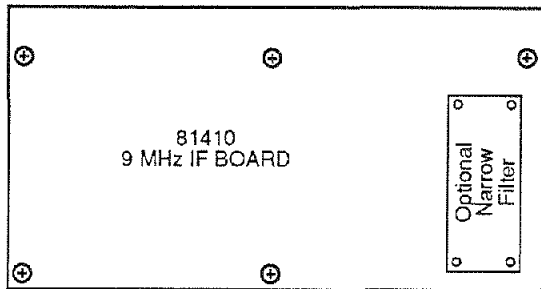

FIGURE 5-3. 9 MHz IF CRYSTAL FILTER OPTION

5-1.4 VOICE READOUT The Voice Readout option, Model 257, announces the displayed frequency whenever the VCE key is pressed twice rapidly in succession. The Voice Readout pc board plugs into an edge card connector located on the Logic Board. Refer to FIGURE 5-4 for the location of the Logic Board and the Voice Readout edge card connector.

After installing the Voice Readout, press the VCE key twice within about half a second and adjust the speech level control,

located on the Voice Readout pc board, to a suitable level.

For more detailed information on the use of the Voice Readout, refer to the instructions included with the Model 257.

5-1.5 FM ADAPTOR The optional Model 256 FM Adaptor enables the OMNI V to transceive ± 5 kHz deviation FM. For information on operating FM with the OMNI V refer to PARAGRAPH 4-1.2 and to the instructions provided with the adaptor.

To install the FM Adaptor, remove the top cover and locate the synthesizer sub-chassis on the left side of the transceiver (with the front panel facing forward).

There are four mounting posts located on the topside of the sub-chassis where the FM board is mounted with the four screws supplied.

Refer to the detailed mounting and connection instructions provided with the Model 256 for the remaining installation steps.

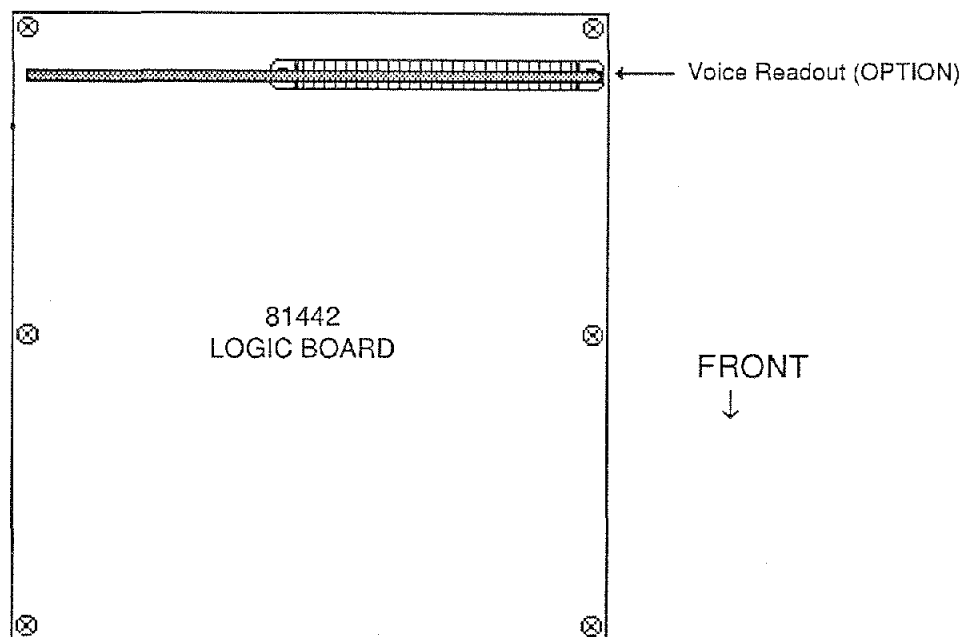

FIGURE 5-4. MODEL 257 OPTION INSTALLATION DIAGRAM

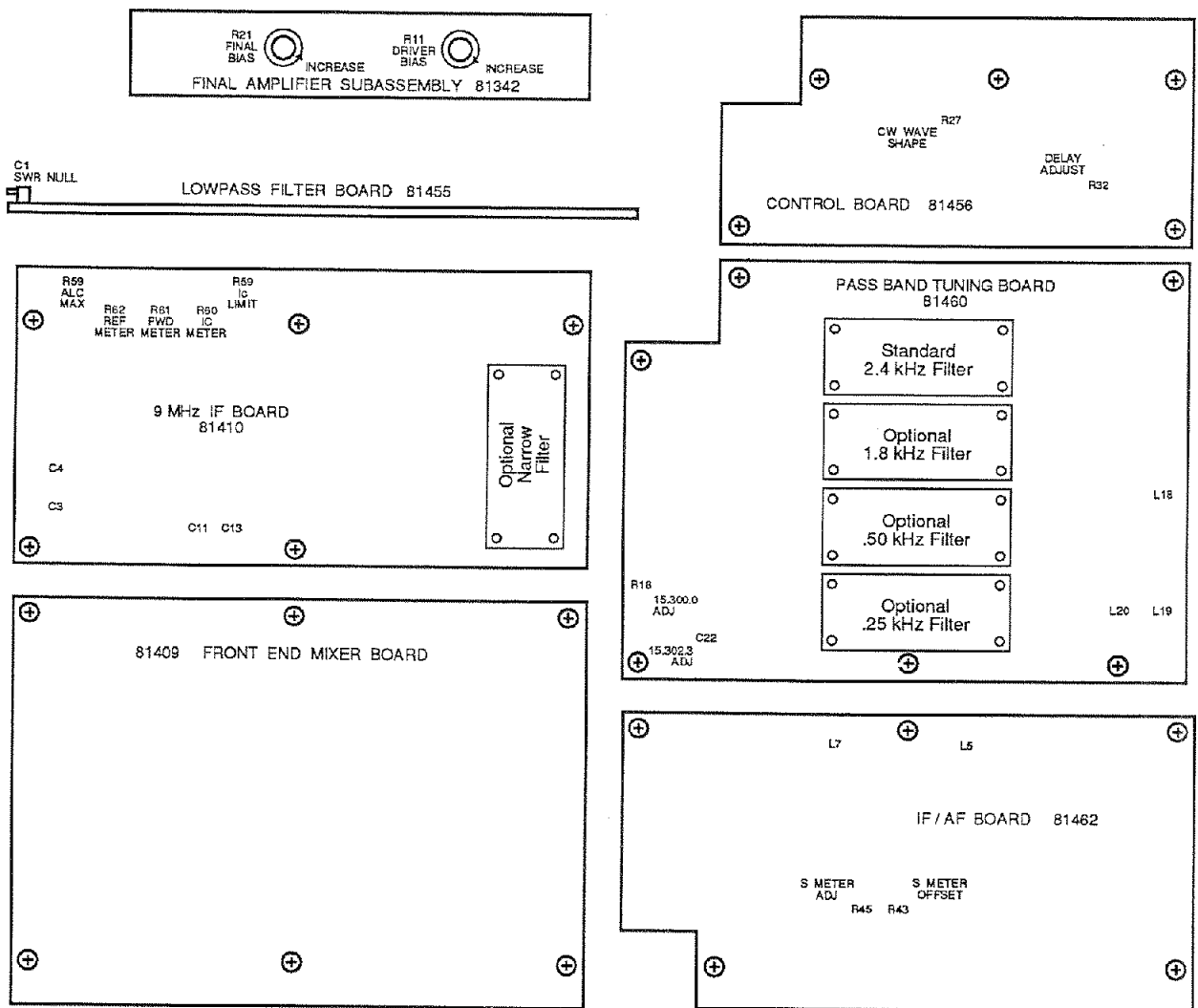

FIGURE 5-5. MODEL 562 ADJUSTMENTS (BOTTOM VIEW)

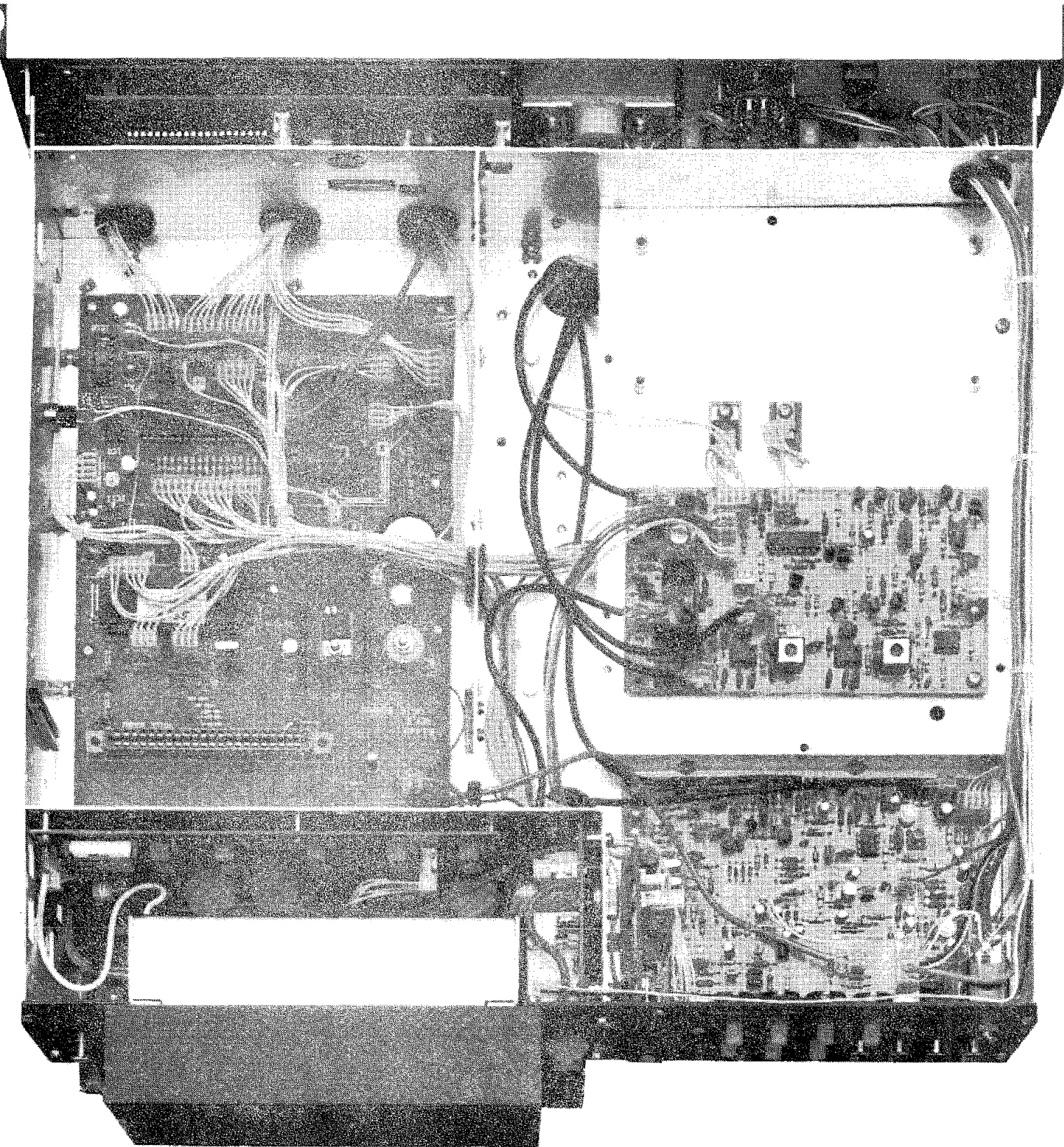

FIGURE 5-6. MODEL 562 TOP VIEW

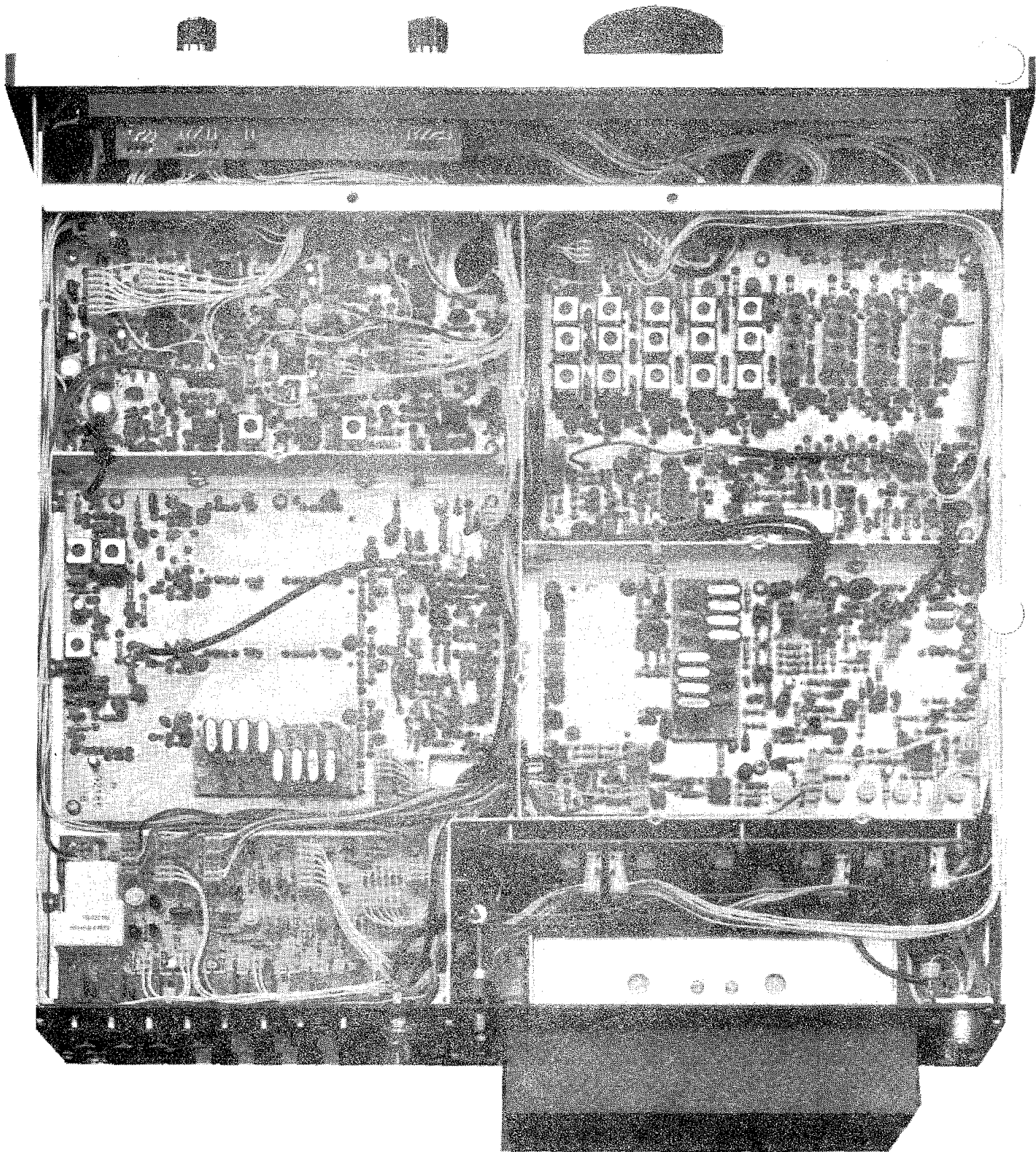

FIGURE 5-7. MODEL 562 BOTTOM VIEW

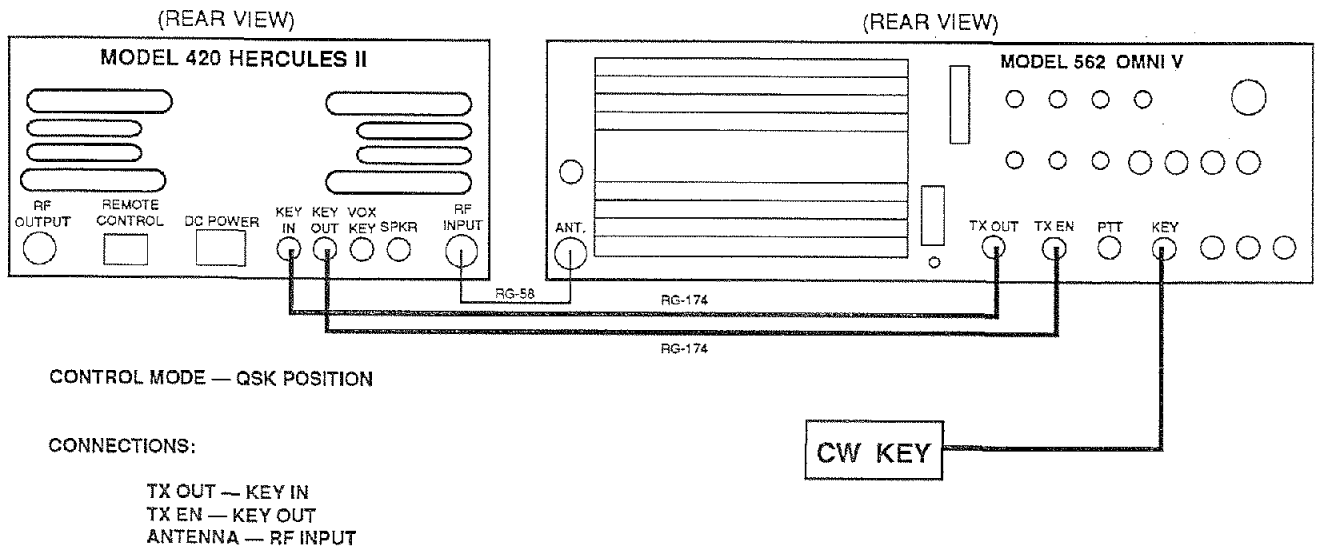

FIGURE 5-8. QSK HOOK-UP WITH HERCULES II AMPLIFIER

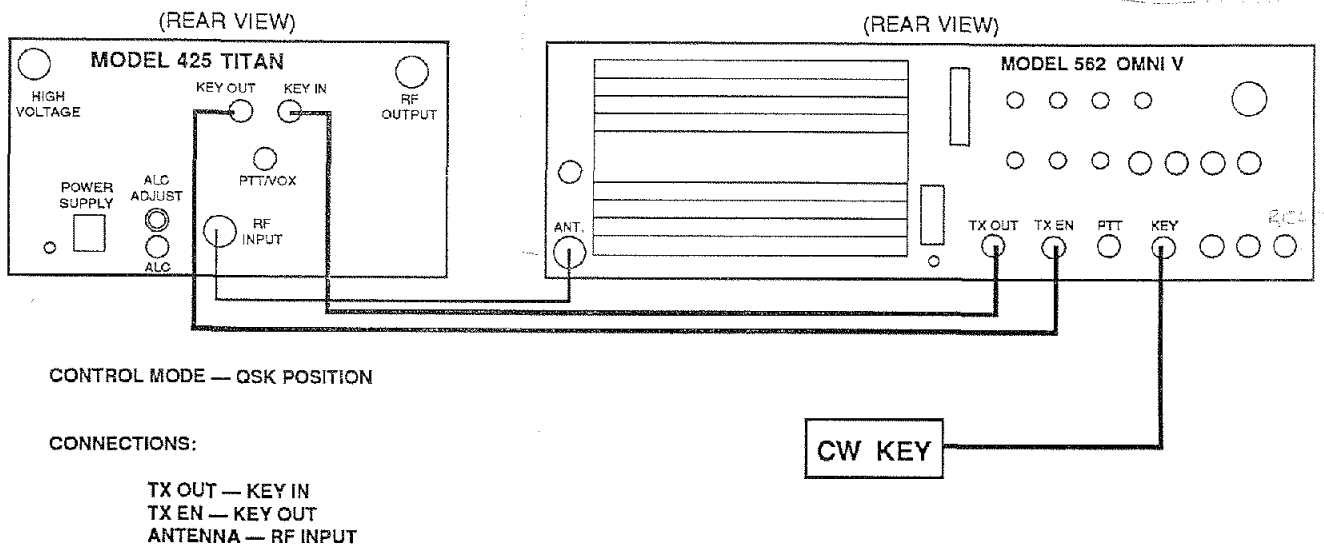

FIGURE 5-9. QSK HOOK-UP WITH TITAN AMPLIFIER

MODEL 258 CONNECTOR CABLE DIAGRAMS

**OMNI V
(DB-25 Male)**

**IBM PC/XT
(DB-25 Female)**

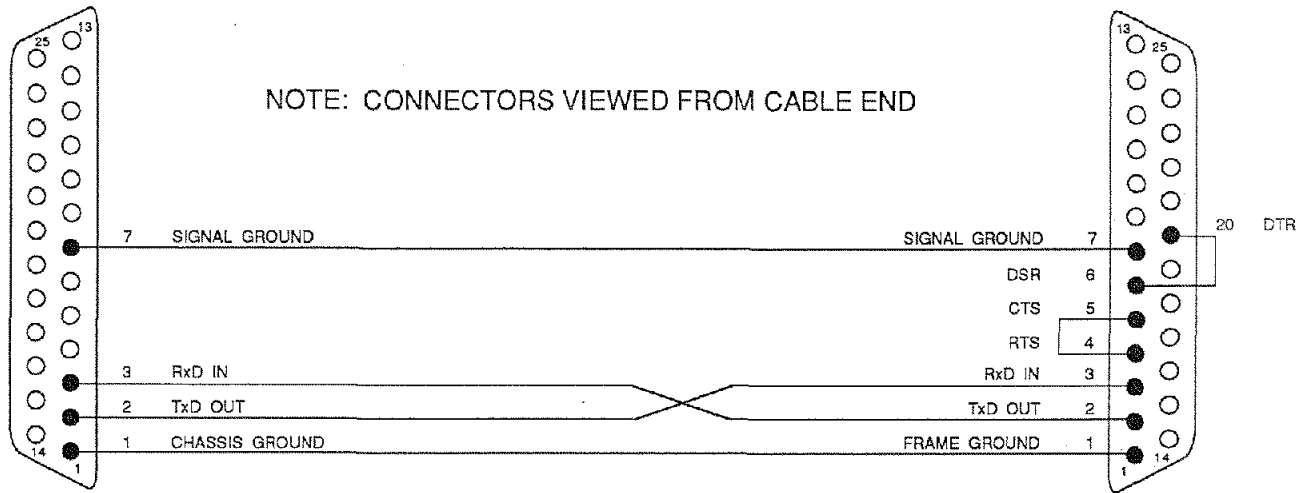

FIGURE 5-10A. IBM PC RS232 CONNECTOR CABLE

**OMNI V
(DB-25 Male)**

**MACINTOSH 512K
(DB-9 Male)**

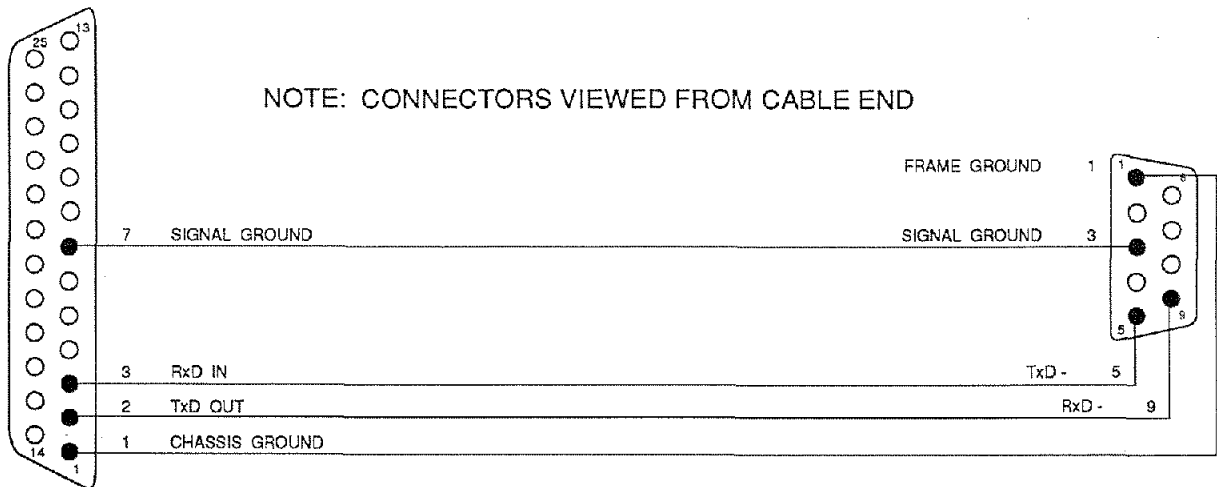

FIGURE 5-10B. APPLE MACINTOSH RS232 CONNECTOR CABLE

MODEL 258 CONNECTOR CABLE DIAGRAMS (Continued)

**OMNI V
(DB-25 Male)**

**COMMODORE 64/128 (USER PORT)
(24-PIN EDGE CARD)**

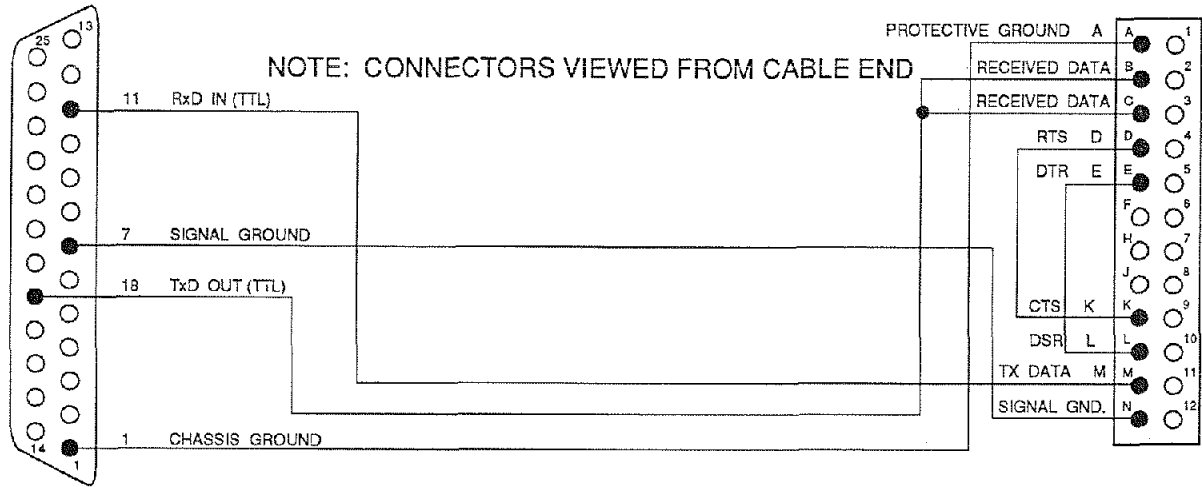

FIGURE 5-10C. COMMODORE 64/128 RS232 CONNECTOR CABLE

**OMNI V
(DB-25 Male)**

**APPLE IIC/E
(5-PIN DIN Male)**

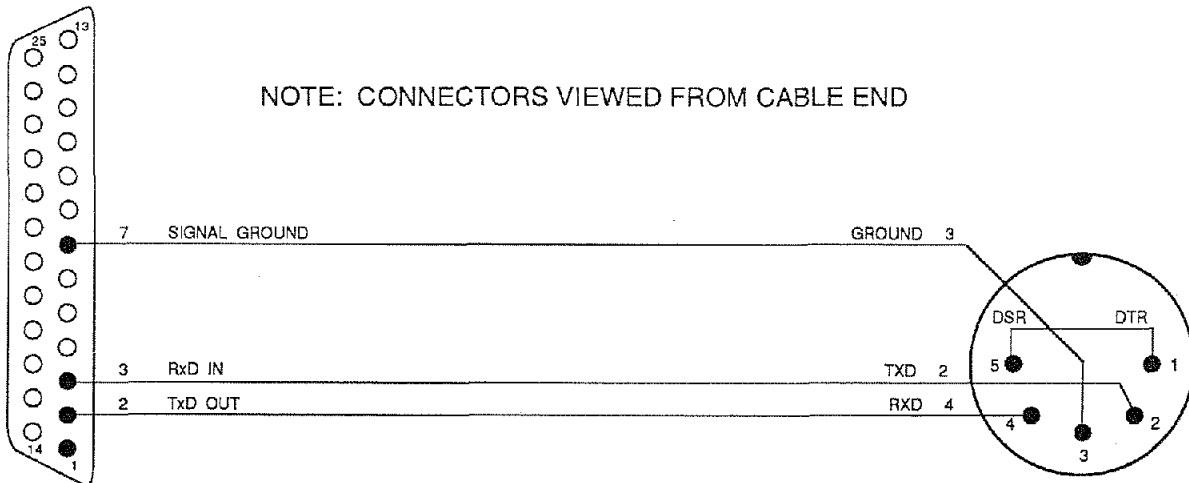
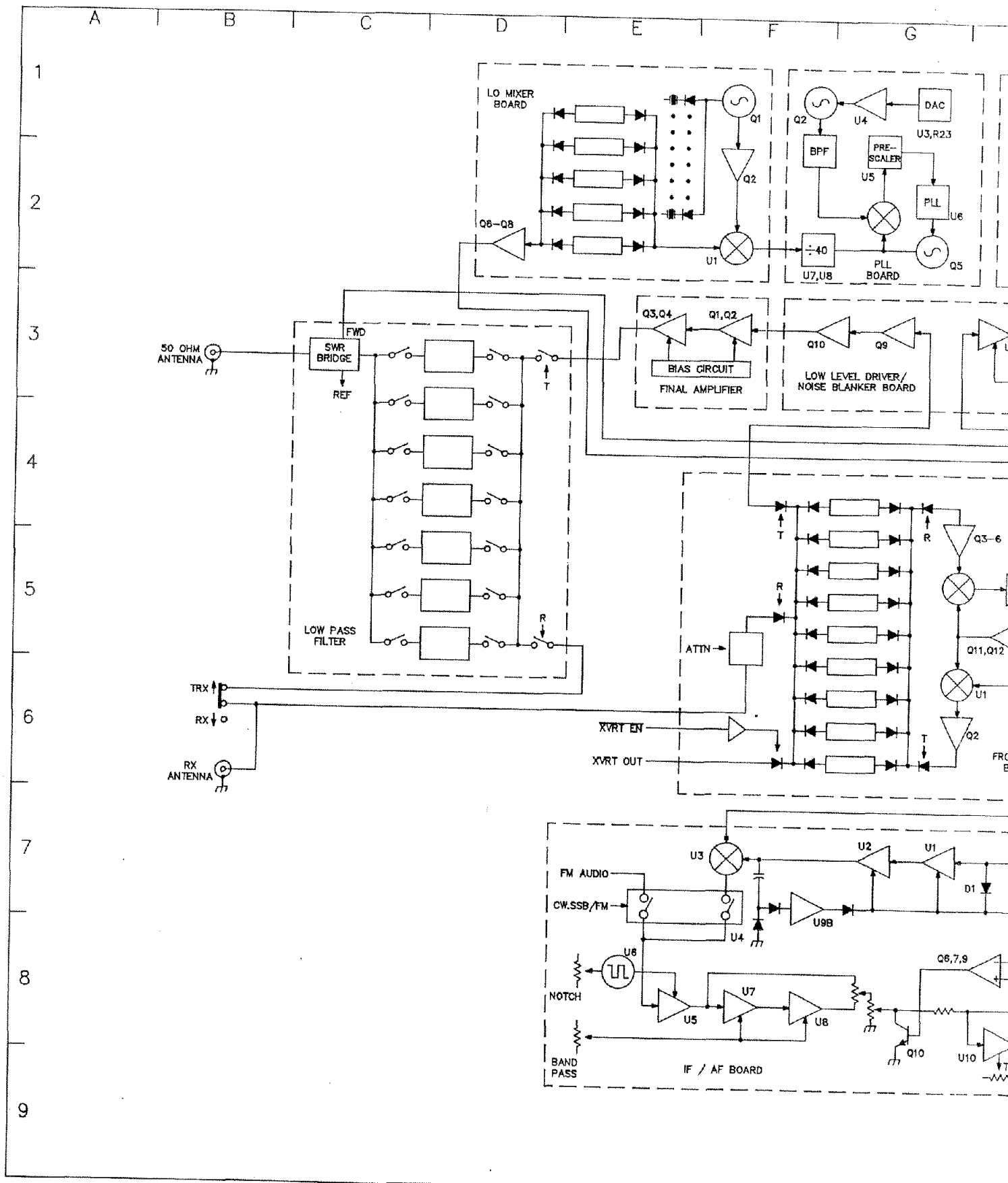

FIGURE 5-10D. APPLE IIC/E RS232 CONNECTOR CABLE

CHAPTER 6

CIRCUIT DESCRIPTIONS AND ILLUSTRATIONS

6-1 INTRODUCTION The following sections contain detailed circuit descriptions for all of the printed circuit board subassemblies used in the OMNI V. Also included are circuit trace drawings and detailed component layout diagrams. These drawings are followed by fold-out schematic diagrams for each circuit board subassembly.



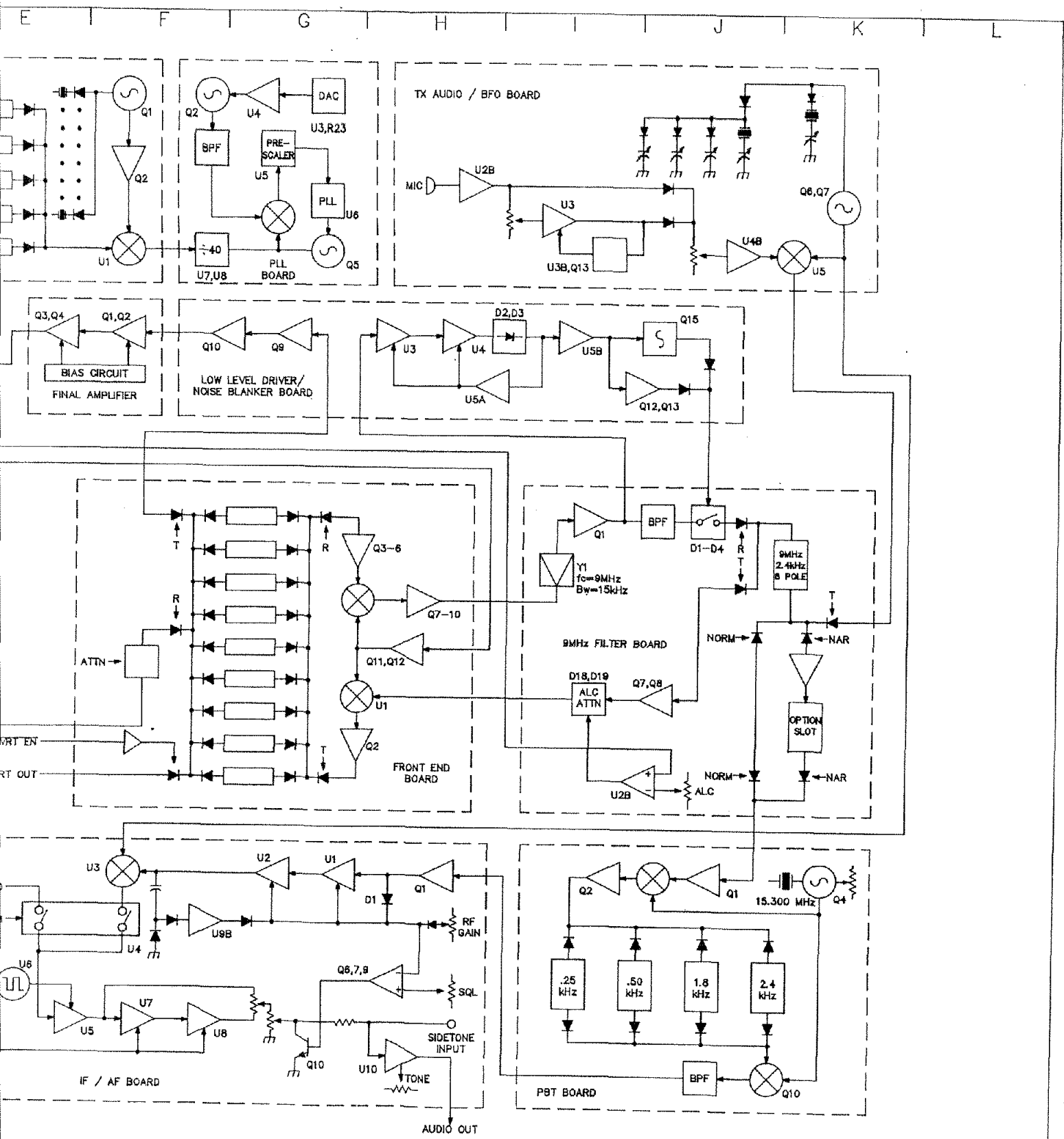

6-3/6-4 blank

FIGURE 6-1 BLOCK DIAGRAM 562

6-2 TRANSMIT LOW PASS FILTER (81455)

This board contains an array of six 5-pole low pass output filters, the T/R switching relays, and a directional coupler for forward power and SWR detection.

Six band lines from the RS232 Connector board enter at connector 8 where they pass through connectors 14 and N to energize filter select relays K3-K16. The buffered band lines also exit connector 14 to the receive Band Pass Filter board for simultaneous selection of receive filters. One of the six lines is high at any one time based on the operating frequency of the transceiver.

The 100 Watt RF output of the PA is connected through the contacts of K1, which is energized by "T" voltage, and proceeds through the selected filter and the primary of SWR bridge transformer T1 to the rear panel antenna connector. Based on operating frequency, the proper low pass filter is automatically selected to attenuate harmonics of the RF PA output signal to an acceptable level before radiation by the station antenna. Bridge transformer T1 and associated circuitry discriminate between forward and reflected power to develop drive voltages at connector 12 for the ALC and RF metering circuits on the 9 MHz Crystal Filter board.

On receive, K1 is open and K2 is energized by "R" voltage, connecting the low pass filtered antenna to the receiver input at connector 13. From connector 13 the receive signal passes through the receive Band Pass Filter board (by way of the rear panel RX/TRX switch) before entering the 9 MHz Crystal Filter board. The combination of transmit low pass filter and receive band pass filter produces an overall band pass response which determines the front end bandwidth of the receiver.

Connector 9 brings "T" and "R" voltages from the control board to the T/R relays K1 and K2. "T" voltage is supplied to the PA through connector 11.

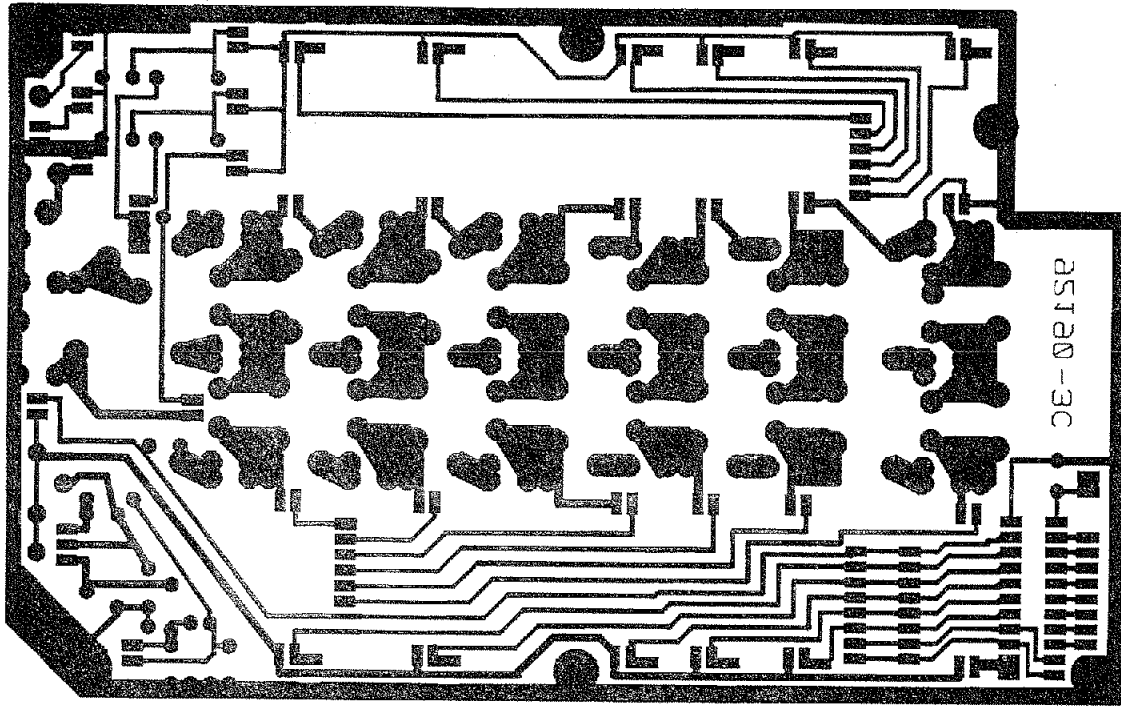

FIGURE 6-2. 81455 TRANSMIT LOW PASS FILTER CIRCUIT TRACE

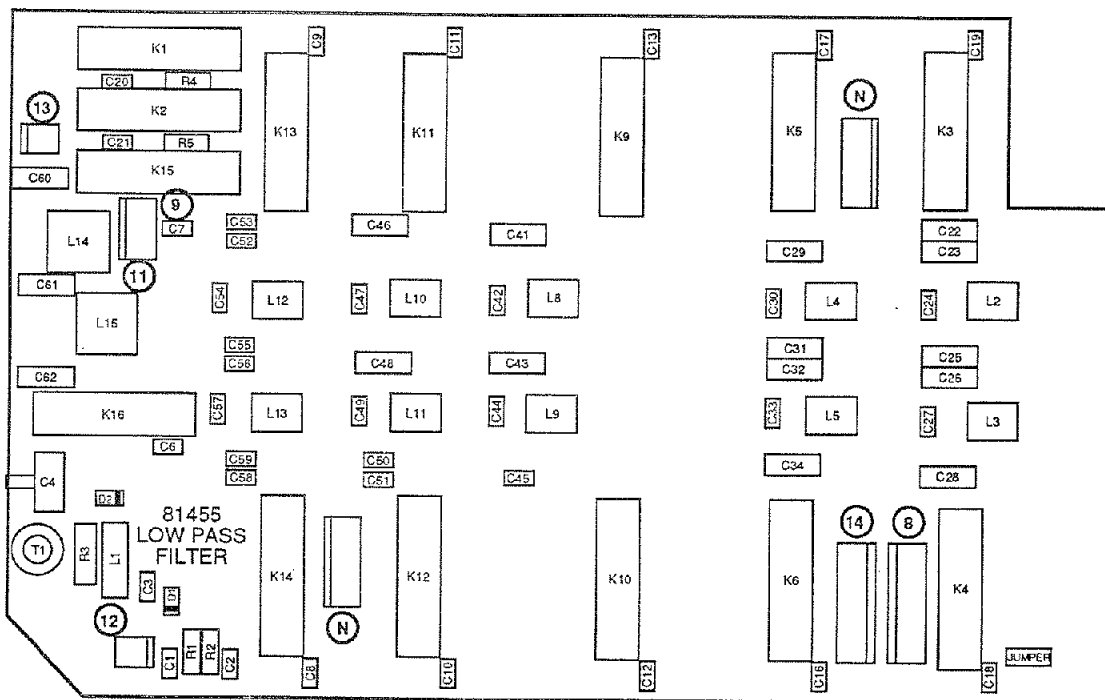

FIGURE 6-3. 81455 TRANSMIT LOW PASS FILTER COMPONENT LAYOUT

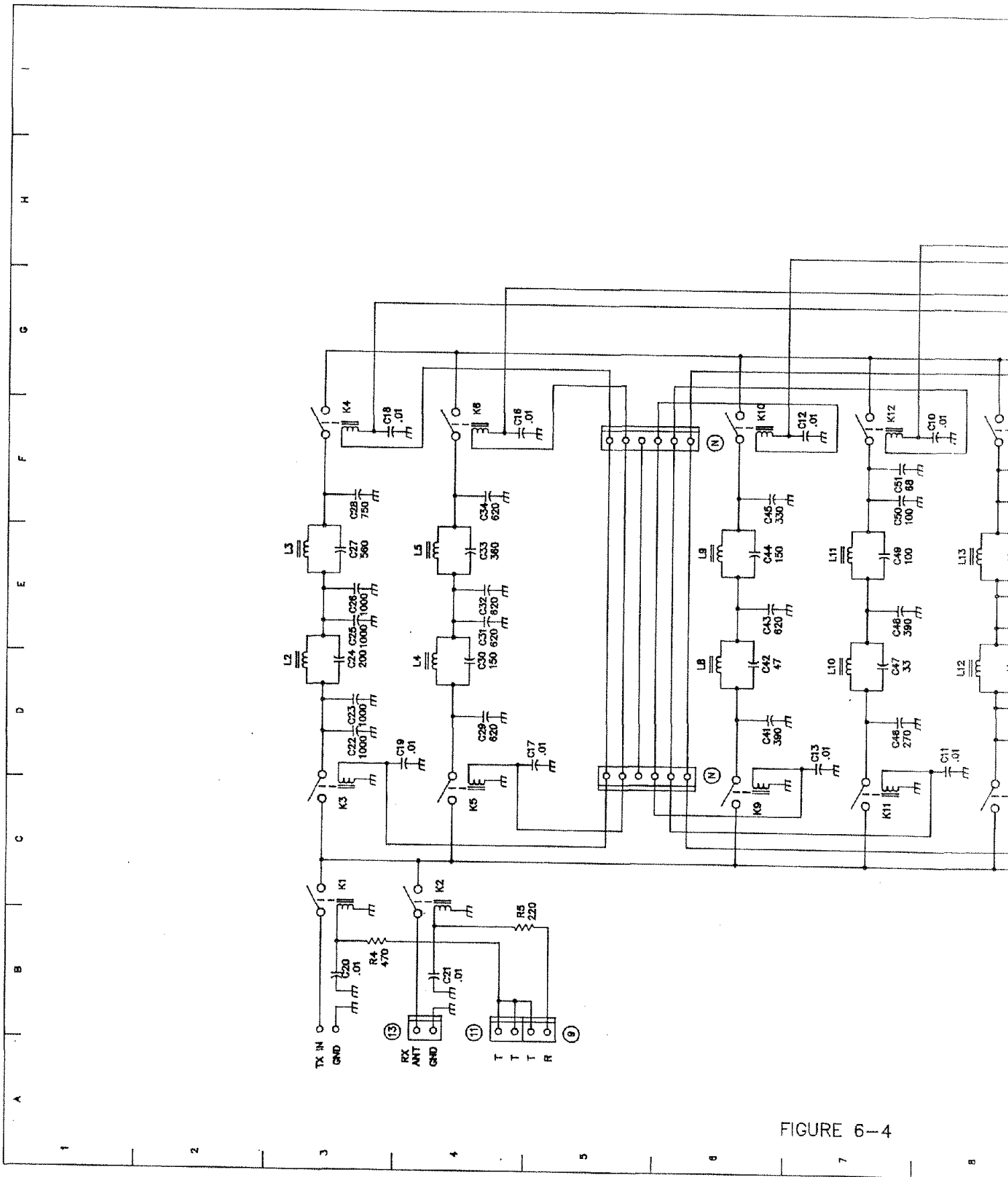

FIGURE 6-4

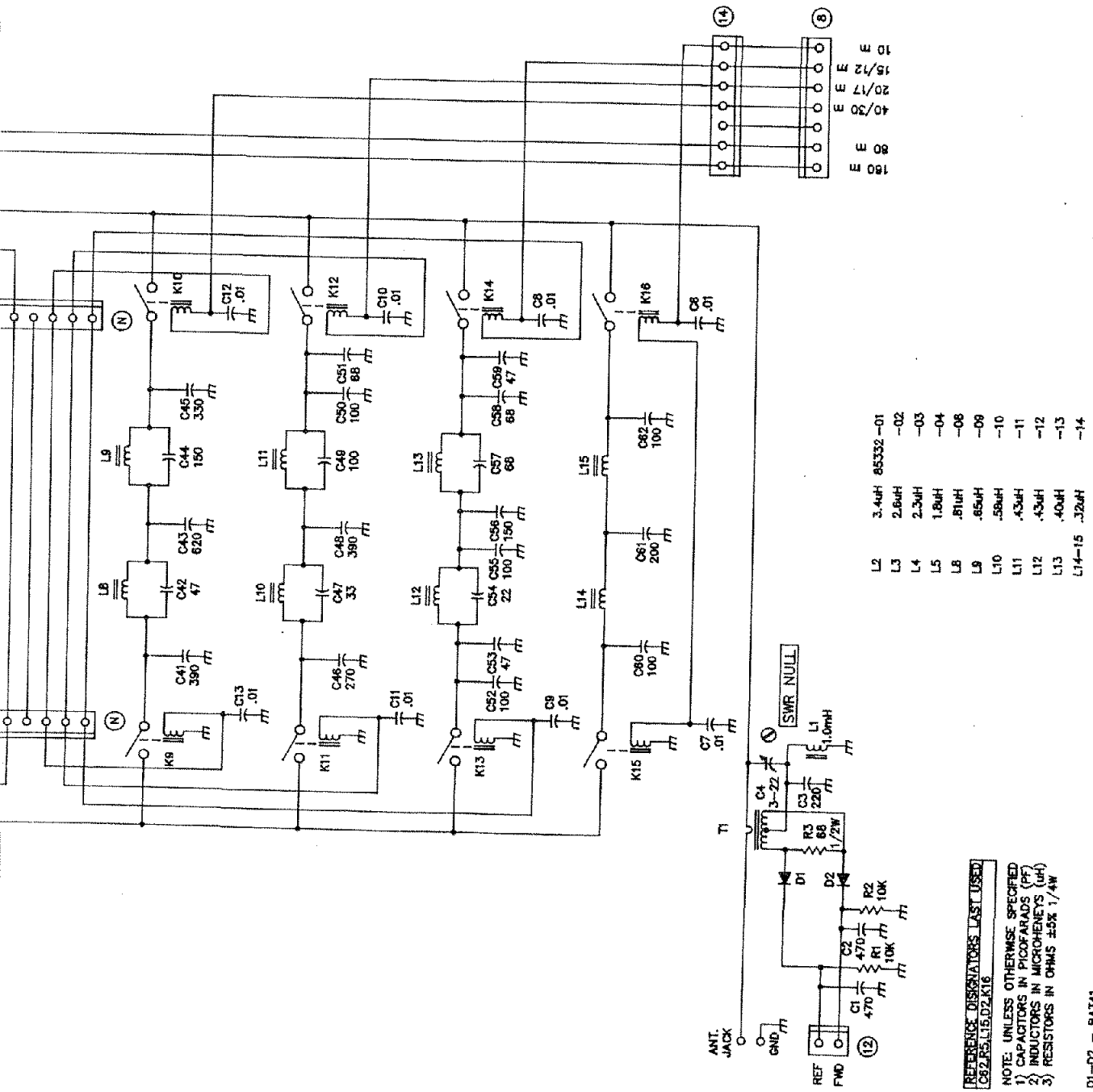

FIGURE 6-4

REFERENCE DISCREPANCIES LAST USED
 C82, R5, L15, D2, K16

NOTE: UNLESS OTHERWISE SPECIFIED
 1) CAPACITORS IN PICOFARADS (PF)
 2) INDUCTORS IN MICROHENRYS (uH)
 3) RESISTORS IN OHMS ±5% 1/4W

D1-D2 - BAT#1

6-7/6-8 blank

6-3 BANDPASS FILTERBOARD (81409)

This circuit board handles the receive functions of band pass filtering, RF preamplifier, receive mixer and mixer post amplifier. Transmit functions include transmit mixer and amplifier, band pass filtering and the switching for the transverter output.

On receive the incoming signals enter at connector 17. Relay K1, R10 and R11 make up the switchable -20 dB attenuator network controlled from the front panel. Following the attenuator is an AM broadcast high pass filter which cuts out everything below about 1.6 MHz. This protects the filter switching diodes from large AM broadcast signals. Transformer T8 and capacitors C4, C5 create a tuneable notch filter which is set to the receiver's IF frequency of 9 MHz. This network helps improve the IF rejection of the receiver, especially on the 40 meter and 30 meter bands where the desired signals are close in frequency to the 9 MHz IF.

Top coupled band pass filters, one for each ham band, are selected from connector 86. These filters protect the front end from unnecessary out of band signals and set the IF and image rejection performance of the receiver.

The grounded gate amplifier stage, Q3 - Q6, provides about 9 dB of gain at a very low noise figure. It's output feeds the high level diode mixer D31. LO drive to the mixer is amplified by Q11 and Q12. The mixer output is terminated through matching transformer T6 into another grounded gate stage Q7 - Q10. This post amplifier is set for about 6 dB gain and drives the 9 MHz two-pole monolithic filter on the 9 MHz crystal filter board through connector 25.

On transmit the active mixer circuit, U1, translates the transmit IF signal from connector 27 to the desired operating frequency. The mixer output is amplified by Q2 and applied to the band pass filters which remove unwanted mixer components from the transmit carrier.

Once filtered, the transmit signal is routed from connector 24 to the low level driver board.

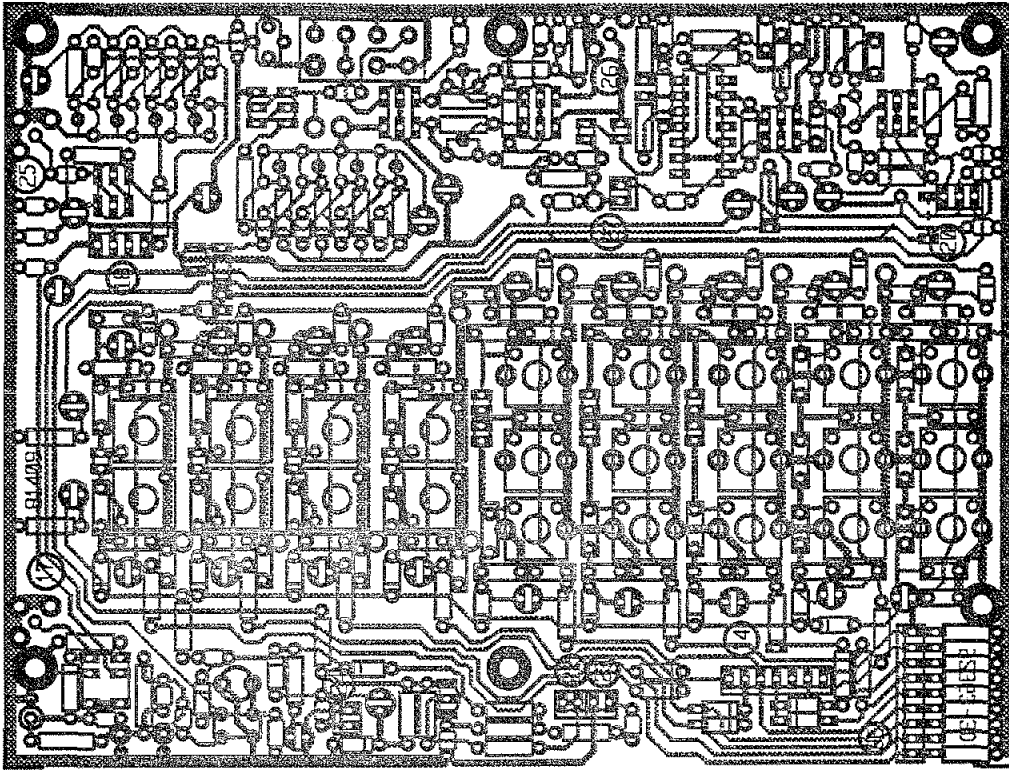

FIGURE 6-5. 81409 BAND PASS FILTER CIRCUIT TRACE

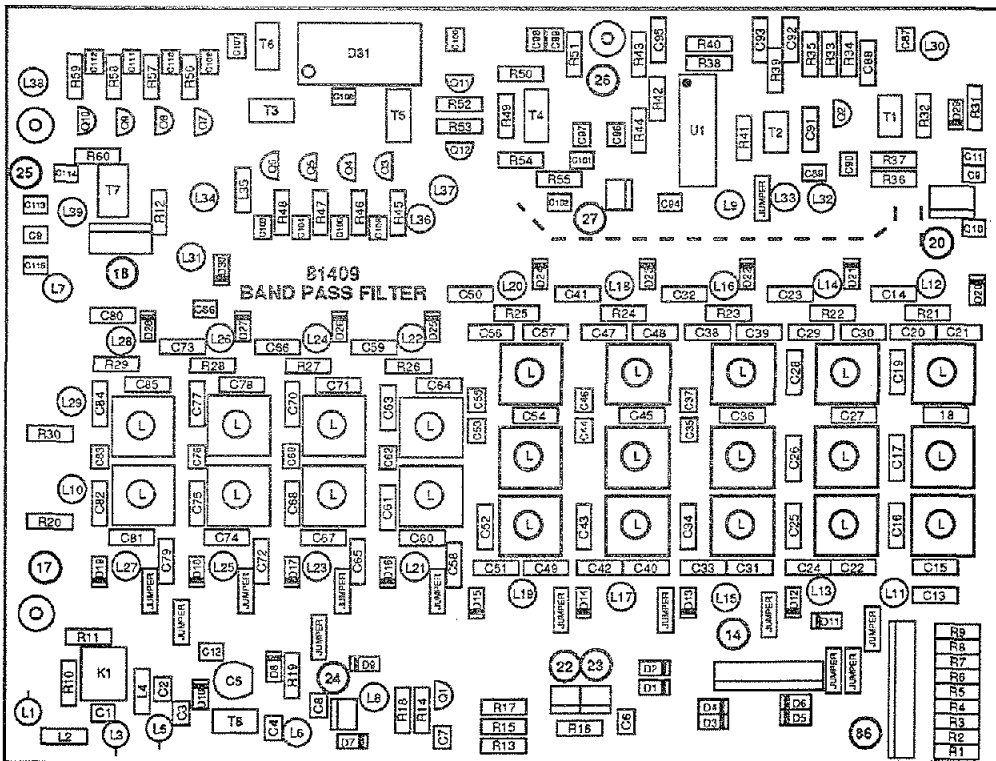

FIGURE 6-6. 81409 BAND PASS FILTER COMPONENT LAYOUT

A B C D E F G

1

2

3

4

5

6

7

8

9

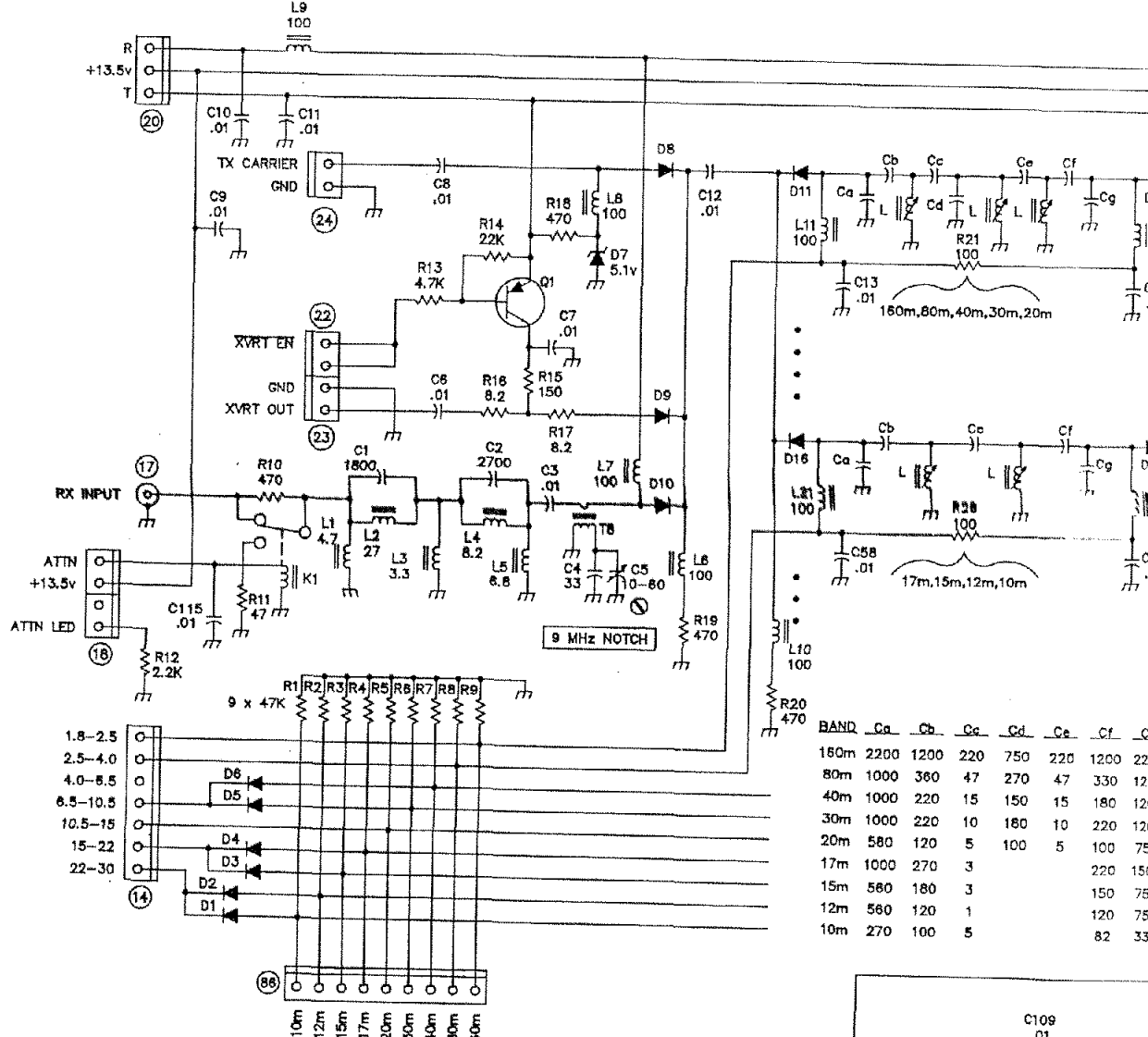

BAND	Ca	Cb	Cc	Cd	Ce	Cf	Cg
160m	2200	1200	220	750	220	1200	2200
80m	1000	380	47	270	47	330	1200
40m	1000	220	15	150	15	180	1200
30m	1000	220	10	180	10	220	1200
20m	580	120	5	100	5	100	750
17m	1000	270	3			220	1500
15m	580	180	3			150	750
12m	580	120	1			120	750
10m	270	100	5			82	330

REFERENCE DESIGNATORS LAST USED
R60, C115, L39, D31, Q12, T8, K1

NOTICE UNLESS OTHERWISE SPECIFIED:
1) CAPACITORS IN PICO FARADS (pF)
2) INDUCTORS IN MICROHENRYS (μH)
3) RESISTORS IN OHMS ±5% 1/4 watt

- D1-D6 1N4148
- D7 1N751A
- D8-D30 BA482
- D31 SYNERGY MICROWAVE
- Q1 CMP-A12
- Q2, Q11, Q12 2N5087
- Q3-Q10 MPS3866
- J310 J310

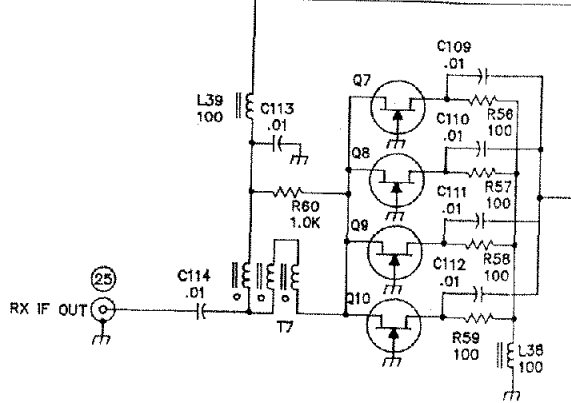

E F G H I J K L

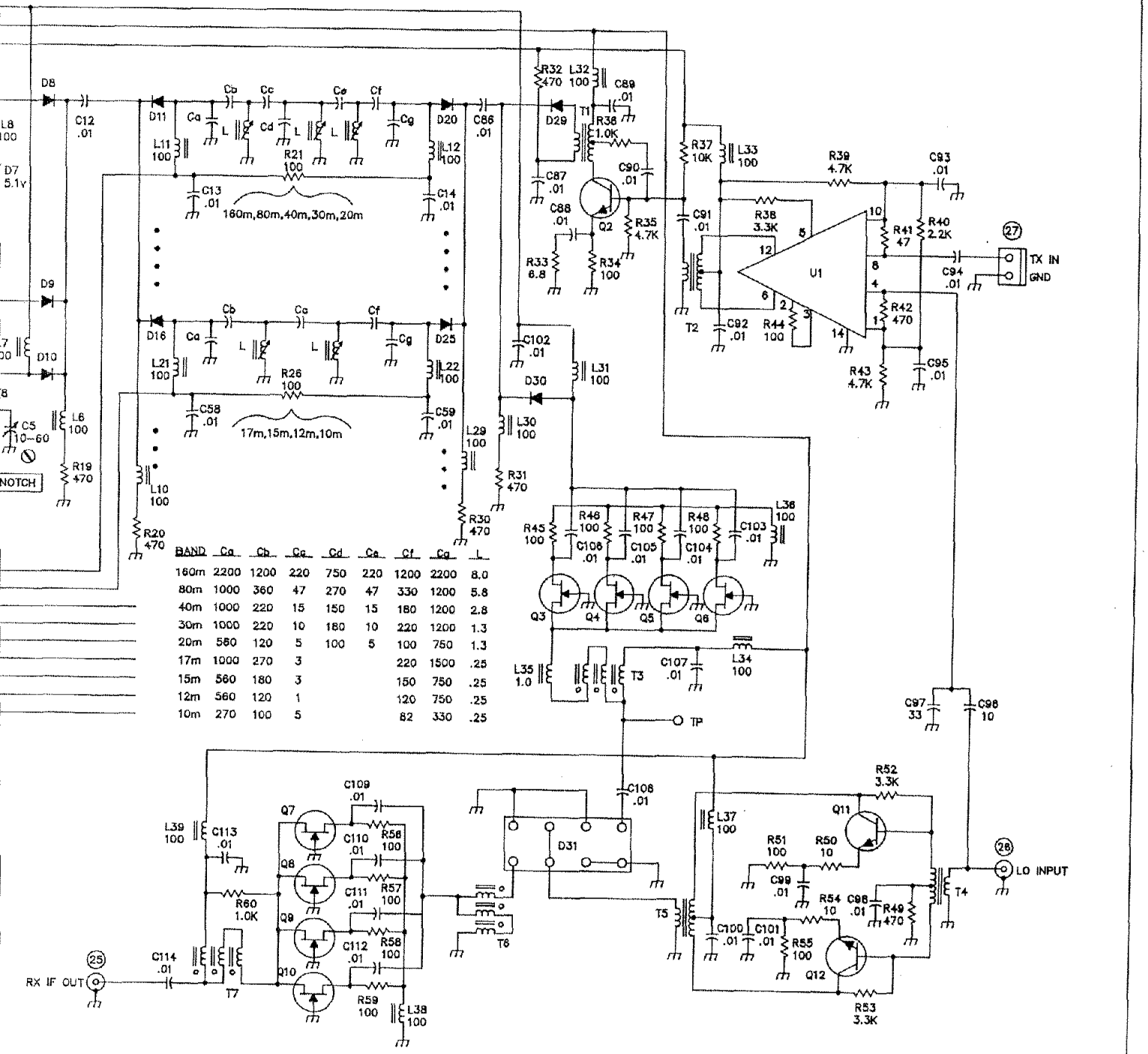

6-11/8-12 blank

FIGURE 6-7 BAND PASS FILTER 81409

6-4 XTAL OSC-LO MIXER (81408)

This board generates the main local oscillator signal which is applied to the transmit and receive mixers in the front end. Band switching information from the microprocessor enters the board at connectors 82 and 83. One of the ten crystals is pin diode switched into oscillator stage Q1. Buffer stage Q2 drives one side of the LO mixer through a low pass filter and also drives the oscillator level detector D25, Q3. Transistor Q3 sets the bias point of the oscillator stage to stabilize the oscillator output level and to limit the drive in the crystals for better aging.

The synthesized 5.0 to 5.5 MHz signal at connector 85 is mixed with the crystal oscillator signal by active mixer U1. The desired mixer product is filtered by one of five band pass filters and then amplified by transistors Q6, Q7 and Q8. The L.O. output is then taken off through a 9 MHz trap, T4 and C78, which helps eliminate undesired products from the mixer, which could leak into the receiver IF.

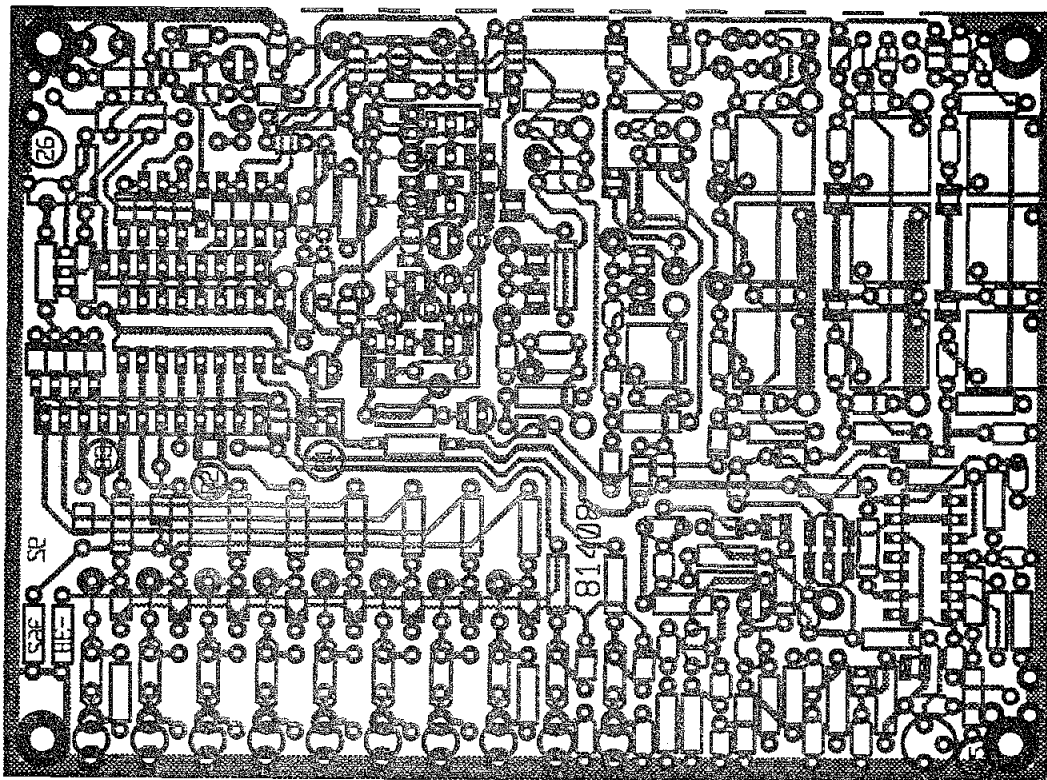

FIGURE 6-8. 81408 XTAL OSC-LO MIXER CIRCUIT TRACE

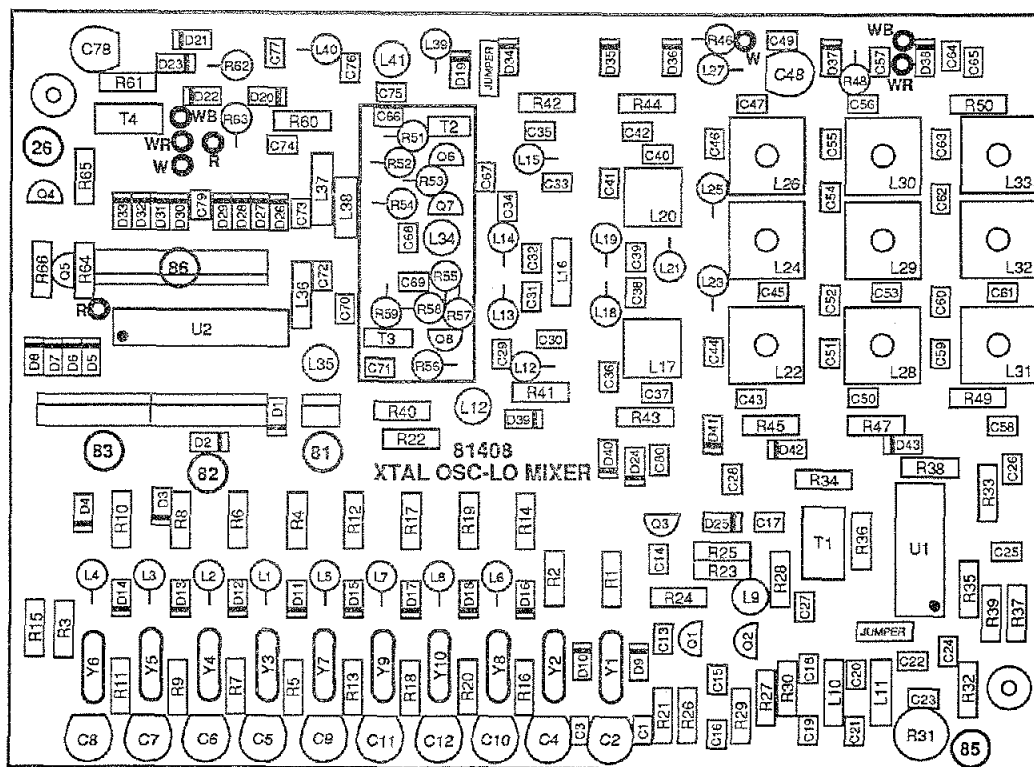
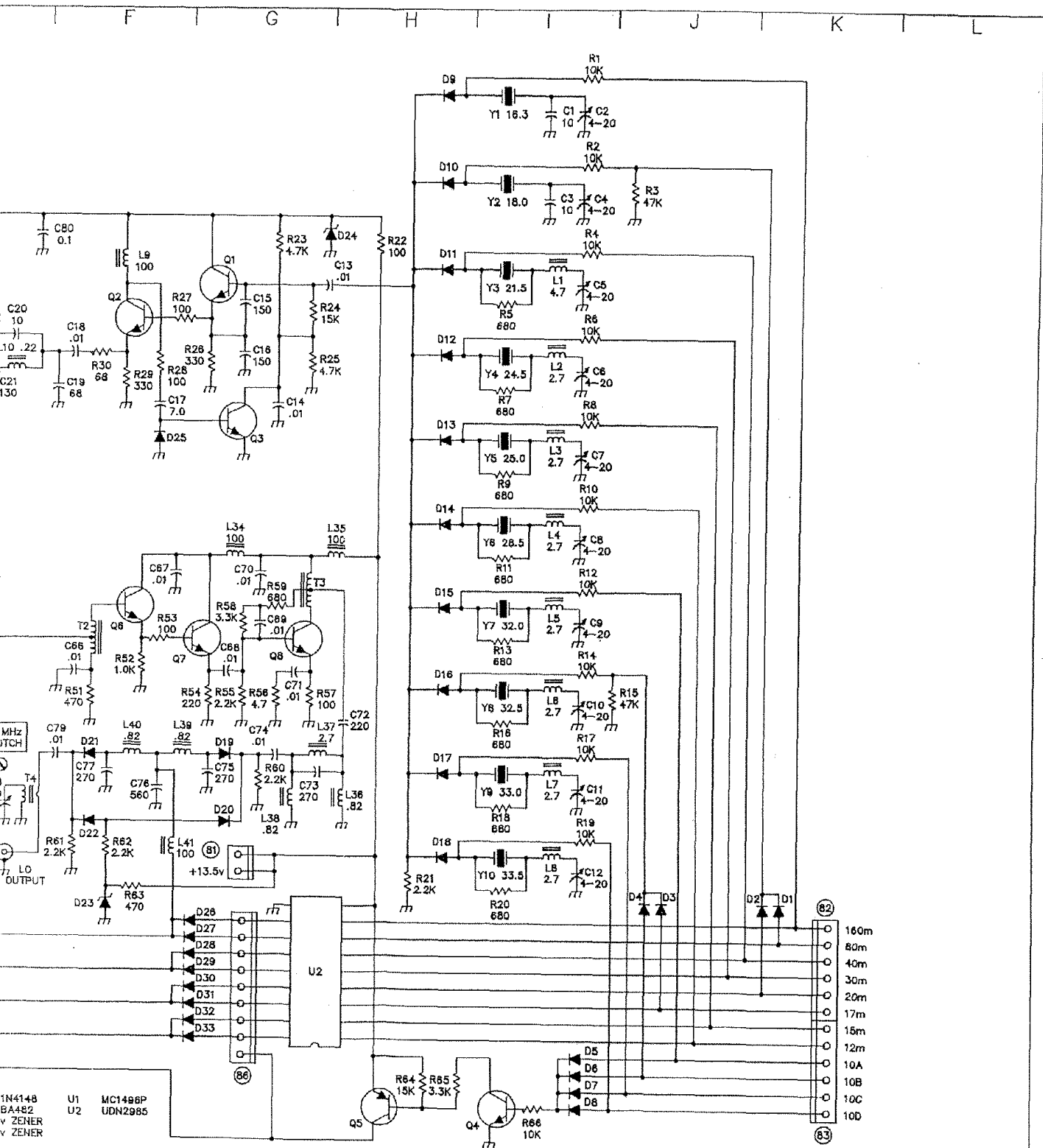
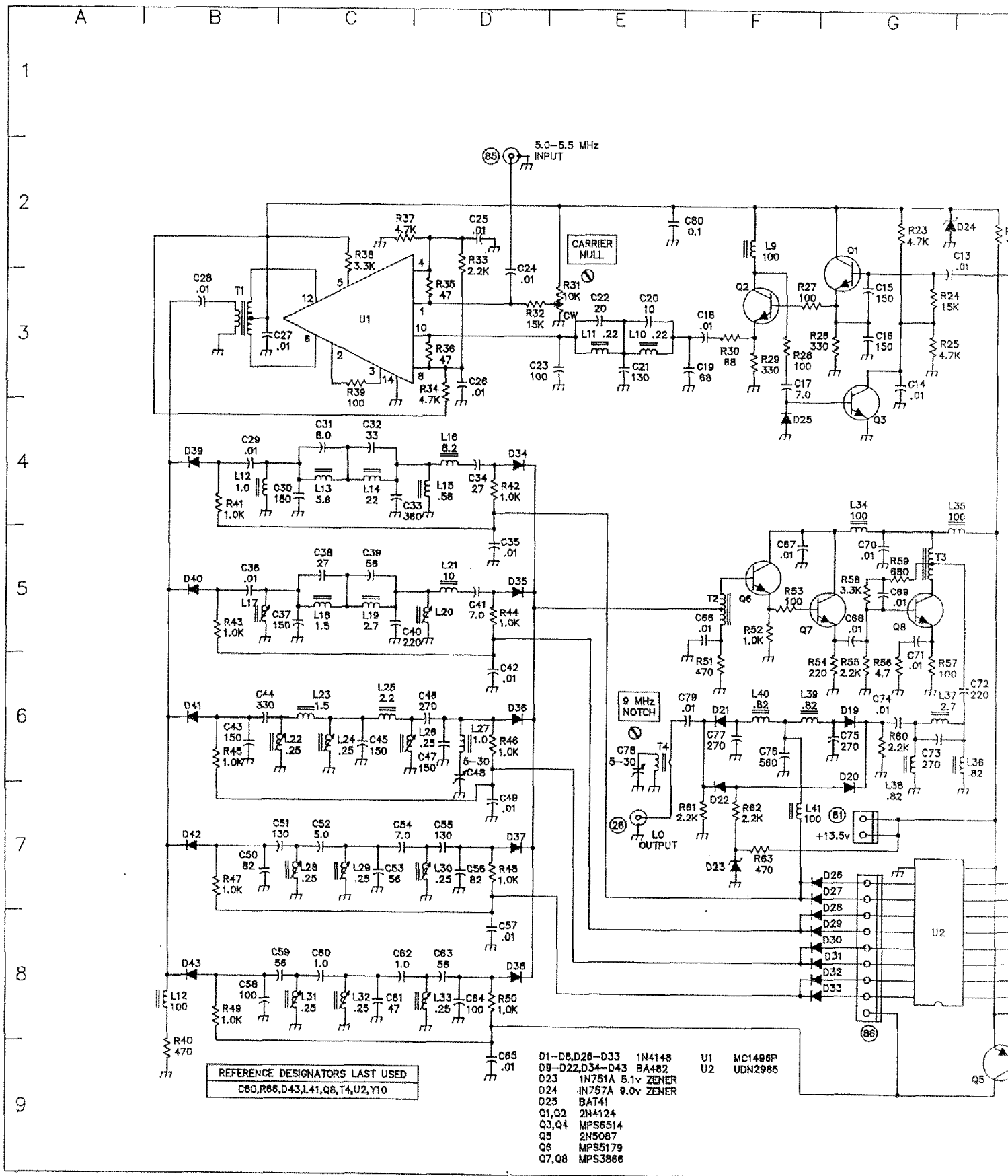

FIGURE 6-9. 81408 XTAL OSC-LO MIXER COMPONENT LAYOUT



6-15/6-16 blank

FIGURE 6-10 XTAL OSC-LO MIXER 81408



REFERENCE DESIGNATORS LAST USED
 C80, R66, D43, L41, Q8, T4, U2, Y10

- D1-D8, D20-D33 1N4148
- D9-D22, D34-D43 BA482
- D23 1N751A 5.1V ZENER
- D24 1N757A 9.0V ZENER
- D25 BAT41
- Q1, Q2 2N4124
- Q3, Q4 MPS6514
- Q5 2N5067
- Q8 MPS5179
- Q7, Q8 MPS3866
- U1 MC1496P
- U2 UDN2985

6-5 9 MHZ CRYSTAL FILTER (81410)

The 9 MHz crystal filter board handles several receive and transmit functions. On receive, signals from the band pass / front end board enter at connector 25 and are applied to the two pole monolithic filter Y1. This filter restricts the receive bandwidth to about 12 kHz for FM reception and also prevents strong out of band signals from reaching the noise blanker circuits.

Amplifier stage Q1 boosts the signal about 10 dB and drives a double tuned filter circuit consisting of T2,T3 and C10-C14. This narrow filter is tuned to 9 MHz and provides the delay necessary for the noise blanker to operate properly. Signals from in front of the filter are buffered by Q2 and sent to the noise blanker amplifier through connector 31. When a noise pulse is detected the blanker sends back a blanking pulse at connector 32. This pulse turns on Q3 and opens the noise gate switch D1-D4 before the noise spike can propagate through the tuned circuit.

Following the noise gate is Y2, the first narrow crystal filter of the receiver. This is an eight pole 2.4 kHz ladder filter with a pass band of 9.0003 to 9.0027 MHz. Receive signals pass through this filter and are either routed to the output connector 38 or to the optional narrow filter position through amplifier Q4. The front panel NAR key signals the microprocessor to turn on transistors Q5 and Q6 through connector 34. This diverts the receive signal to gain stage Q4 which makes up for the extra loss in the optional filter. Two gain settings are jumper selectable to equalize the signal levels through both wide and narrow filters.

In transmit the double side band suppressed carrier signal from the TX audio board enters at connector 37. The unwanted sideband is stripped off by filter Y2 and the resulting SSB transmit signal is amplified by transistor stages Q7 and Q8. Pin attenuator diodes D18

and D19 form an output level control which regulates the amount of transmit carrier feeding the rest of the transmit chain. The biasing of these diodes is determined by an ALC feedback voltage developed by U2B. U2B compares the forward power indication from the SWR bridge at connector 12 to the ALC reference voltage set by the front panel RF PWR control. If the forward power attempts to rise or fall, the feedback adjusts the amount of drive to the transmit stages to hold the output steady.

Power amplifier current is sampled across a dropping resistor on the DC input board. This voltage drop at connector 7 is amplified by U1A and U1B and is used as another feedback signal to control the drive to the transmitter. Trimmer potentiometer R59 is set such that amplifier current above about 20 amperes begins to limit transmitter drive. This protects the final amplifier transistors from excessive current when there is a load mismatch.

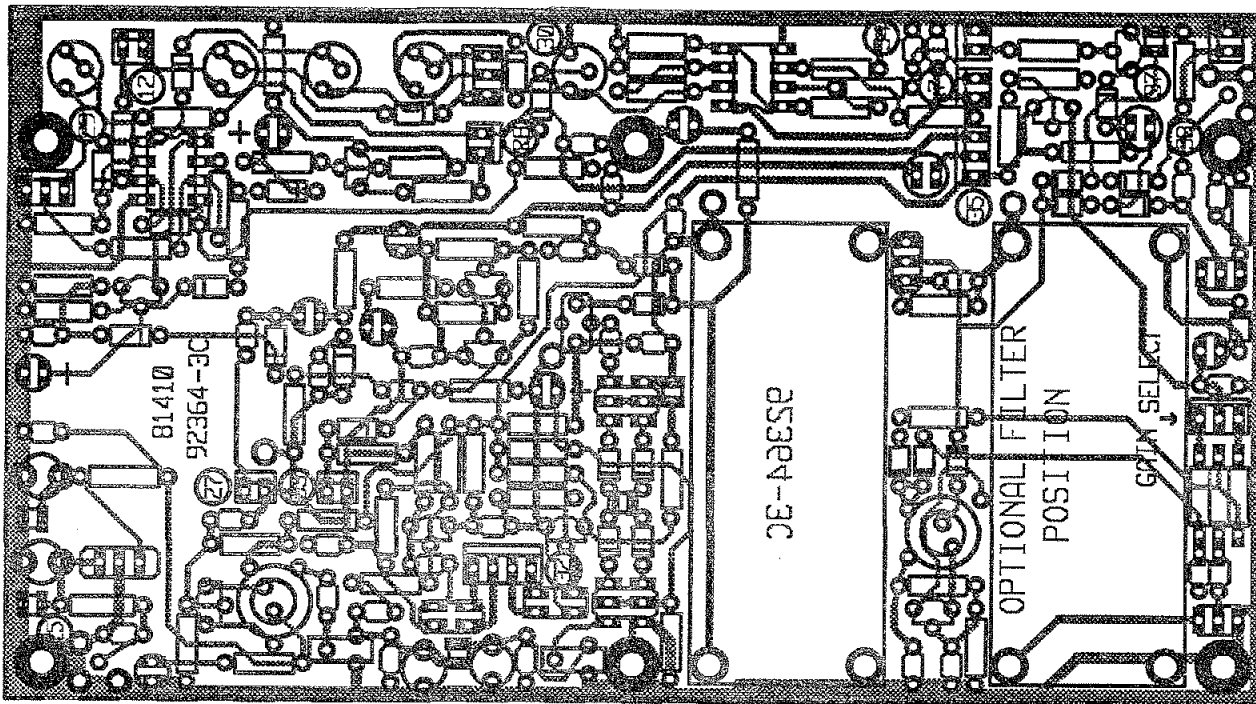

FIGURE 6-11. 81410 9 MHz CRYSTAL FILTER CIRCUIT TRACE

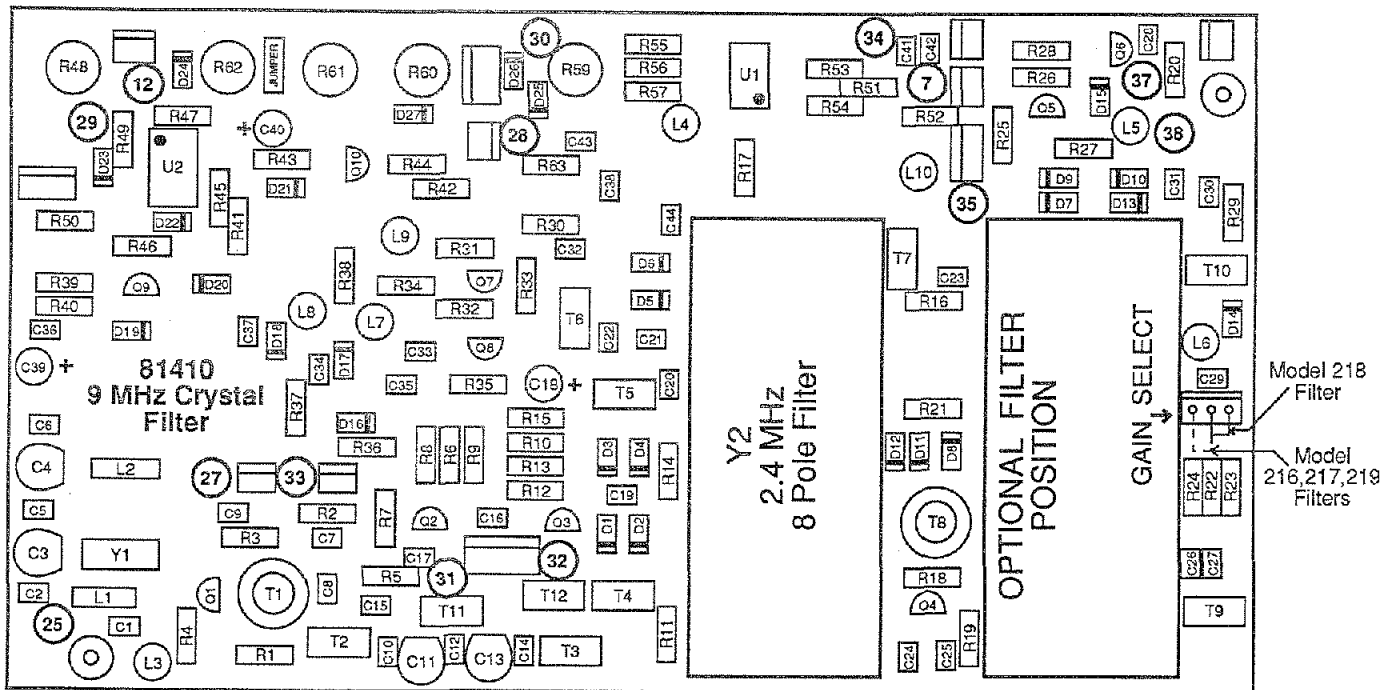
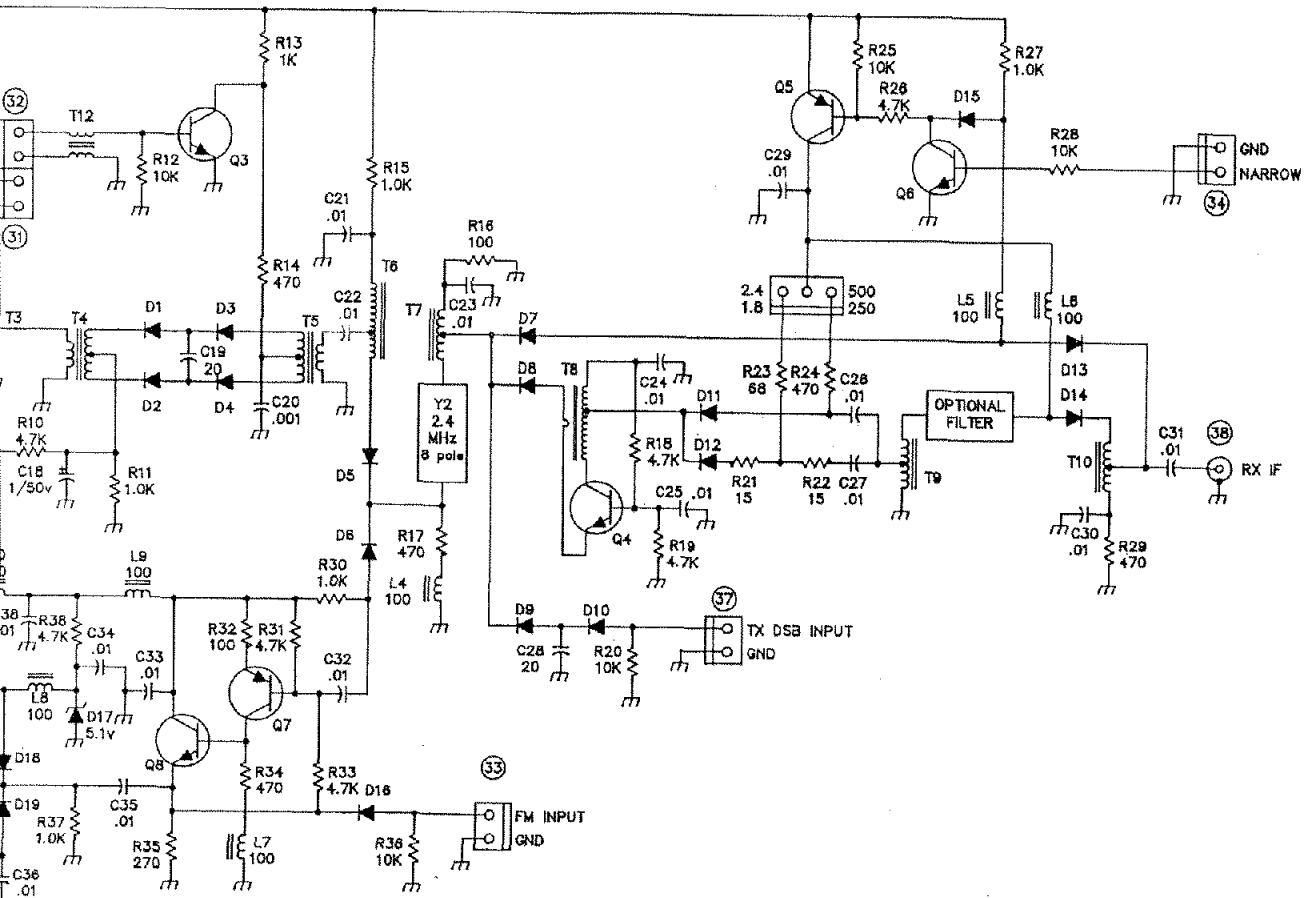

FIGURE 6-12. 81410 9 MHz CRYSTAL FILTER COMPONENT LAYOUT



REFERENCE DESIGNATORS LAST USED
 C44, D27, L10, Q10, R63, T10, U2, Y2

- U1, U2 LM358N
- Q1, Q4 MPS3866
- Q2 MPS5179
- Q3, Q6, Q10 MPS6514
- Q5, Q7 2N5087
- Q9 MPSA14
- D1-D14, D16 BA482
- D15, D20-D27 1N4148
- D17 1N751A
- D18, D19 HP 1N5767

ic LIMIT

6-19/6-20 blank

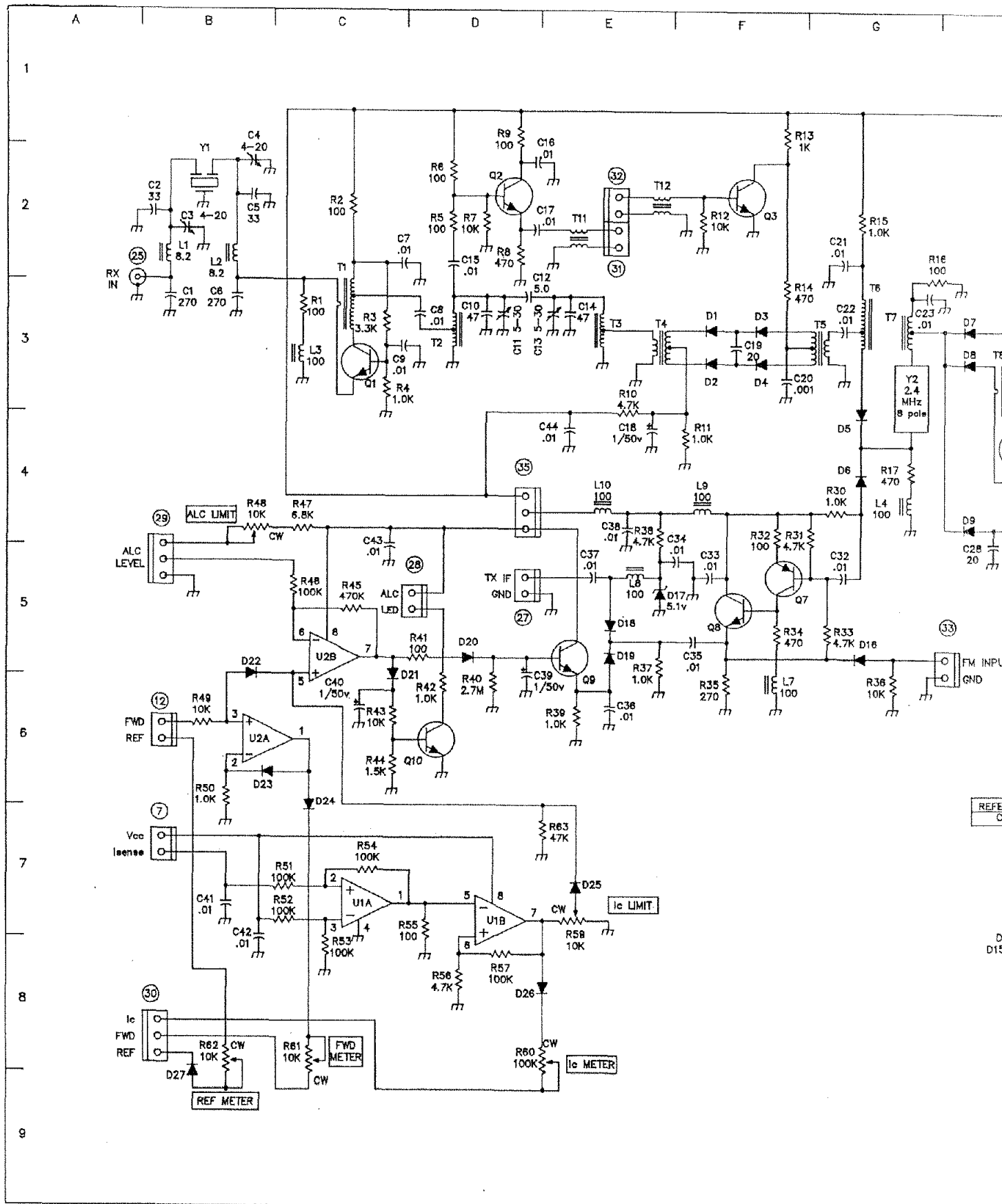

6-6 PASSBAND TUNING BOARD (81460)

The passband tuning board accepts a 9 MHz receive IF signal from the 9 MHz Crystal Filter board at connector 38, converts it down to approximately 6.3 MHz and passes it through one of four crystal filters (the 2.4 kHz filter is standard). Filter select lines from logic board connector 41 determine which filter is selected. After filtering, the signal is converted back to 9 MHz and sent to the IF/AF board via connector 43. The exact frequency of the signal before filtering is set by the front panel PBT control through connector 42.

The 9 MHz IF signal, from the 9 MHz Crystal Filter board at connector 38, occupies a 2.4 kHz wide band (9.0003-9.0027 MHz) on SSB/CW and FSK. This signal is amplified by low noise amplifier Q1 and input to the RF port of mixer D1. The LO port of this mixer is driven with approximately 15.3 MHz from VCXO Q4 through buffer Q5 and LO amplifier Q3. The exact frequency of the LO signal is determined by the bias on tuning diode D2 which is set by the front panel PBT control through connector 42. The output of the VCXO is also buffered by Q6 and Q7 and used as the LO signal to the output mixer Q10. This arrangement insures that the IF signal exits the PBT board on exactly the same frequency as it entered, regardless of the VCXO frequency.

As an example of passband tuning board operation, it will be assumed that the receiver is operating in USB mode with the 2.4 kHz filter selected. With the PBT control centered, Q4 oscillates at 15.3 MHz, producing an output of 6.2973-6.2997 MHz from mixer D1. This matches exactly the passband of the 2.4 kHz sideband filter which is selected by diode switches D3, D13 and D14. In this condition the 8-pole response of the 2.4 kHz filter on this board is combined with the 8-pole response of the 2.4 kHz filter on the 9 MHz Crystal Filter board to produce an overall 16-pole IF filter response of 2.4 kHz bandwidth for the

receiver. If the PBT control is rotated counter-clockwise, the frequency of the VCXO goes down (as much as 1.6 KHz for fully CCW), moving the output frequencies of mixer D1 down in relation to the passband of the 2.4 kHz filter on this board, filtering out some of the lower frequencies in the 2.4 kHz bandwidth mixer output signal. This effectively reduces the IF bandwidth of the receiver by the amount of the frequency shift of the VCXO. This reduced bandwidth signal is now mixed again with the VCXO in Q10 to return the remaining signals to their original frequencies. The end effect of this is that, as the PBT control is rotated counter-clockwise, the original 2.4 kHz USB passband is progressively reduced by as much as 1.6 kHz, and the reduction is accomplished by moving the upper edge of the passband downward, reducing the higher frequency audio tones of the received signal. Rotating the PBT control clockwise from center again reduces the passband, but this time the reduction is accomplished by shifting the lower passband edge upward, reducing the lower frequency audio tones.

The operation of passband tuning with other modes or filters selected is similar to the above except that in LSB the direction of control rotation is reversed with respect to audio frequency response (to preserve the correspondence of control movement to the frequency location of the received signals), and narrow filters have less useable range of shift.

Power to the output mixer Q10 is supplied through Q9 which is forward biased during receive by Q8. The input preamplifier Q1 and bias to VCXO Q4 are supplied by "R" voltage from control board connector 39. Regulated "+REG" voltage supplies the VCXO and buffers Q3 and Q5. The remaining stages are powered by 13.5 Volts from connector 39.

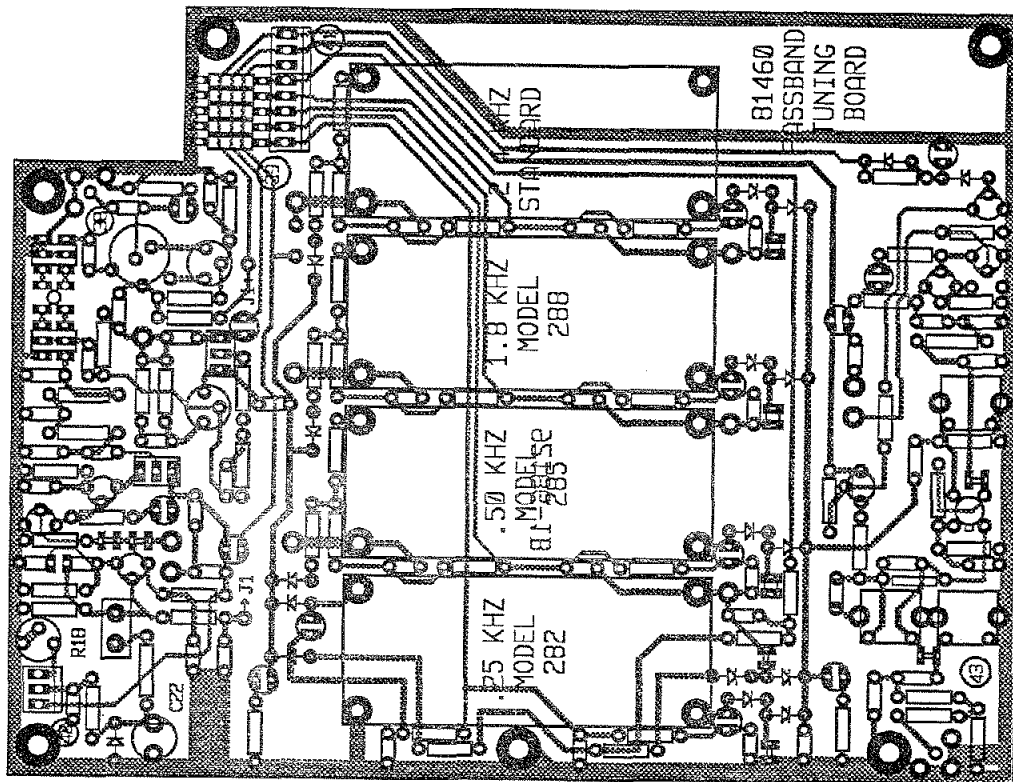

FIGURE 6-14. 81460 PASS BAND TUNING BOARD CIRCUIT TRACE

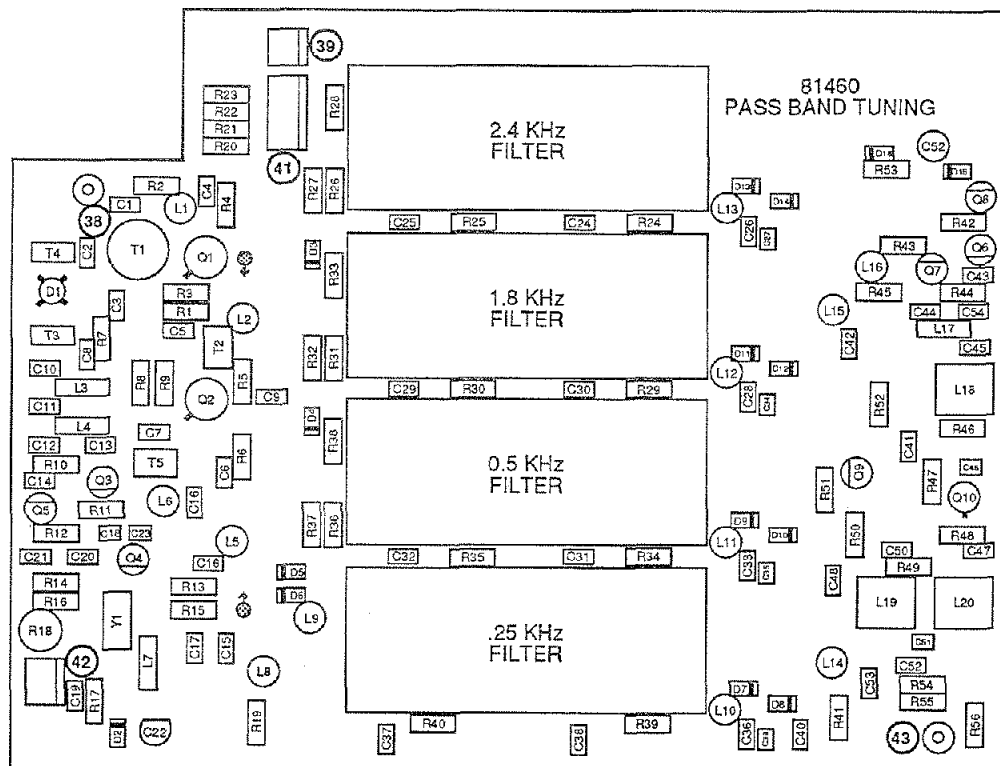
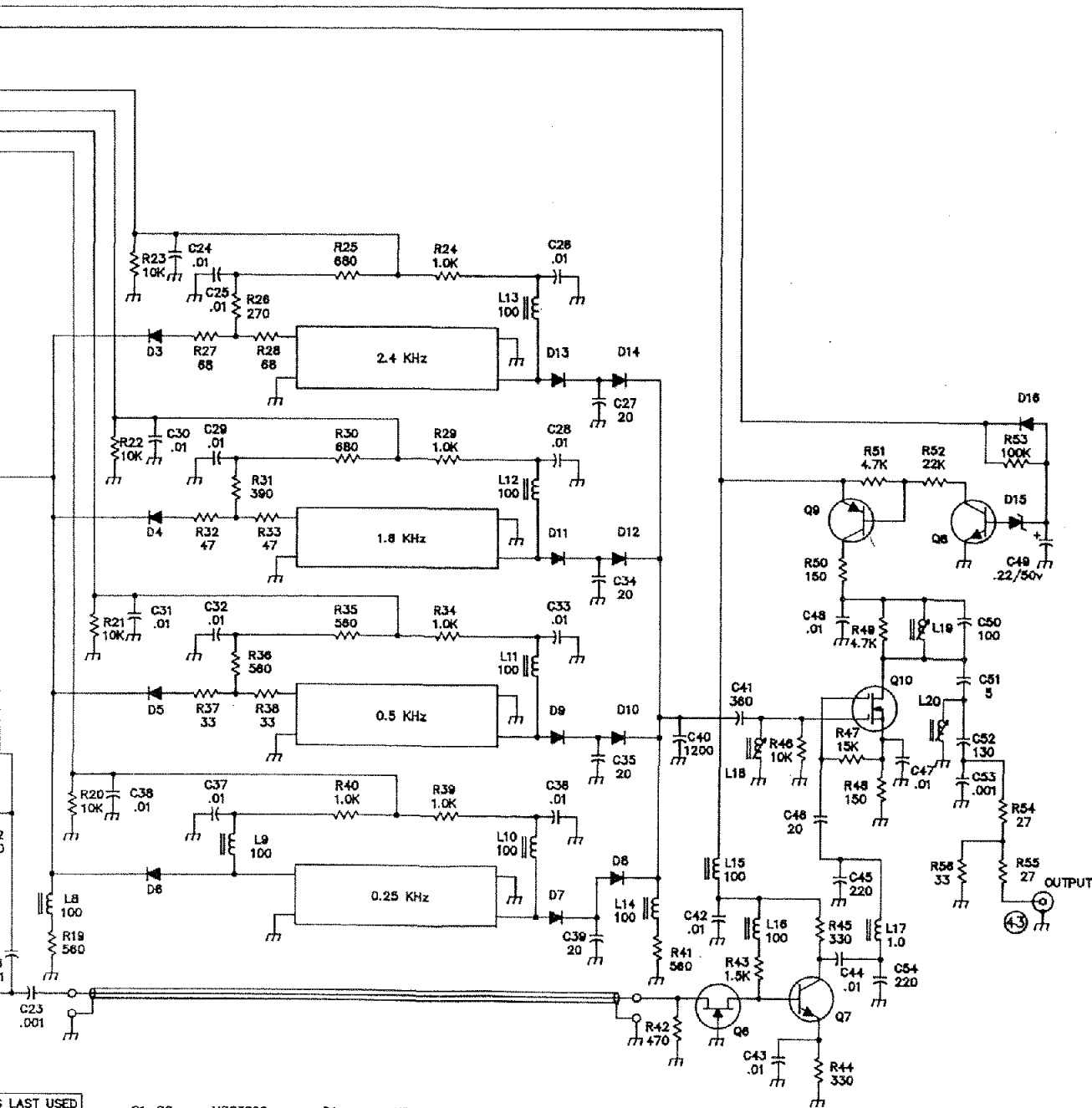

FIGURE 6-15. 81460 PASS BAND TUNING BOARD COMPONENT LAYOUT



LAST USED	Q1-Q2	MPS3866	D1	ND487C1-3R
	Q3,Q4,Q7	2N4124	D2	KV-3902
	Q5,Q6	3J10	D3-D14	BA482
SPECIFIED	Q8	MPS6514	D15	1N751A
VARADS (pf)	Q9	2N5087	D16	1N4148
INDUCTORS (μH)	Q10	3N201	Y1	15.302.3 MHZ
RESISTORS (1/4 watt)				

6-23/6-24 blank

FIGURE 6-16 PASS BAND TUNING BOARD 81460

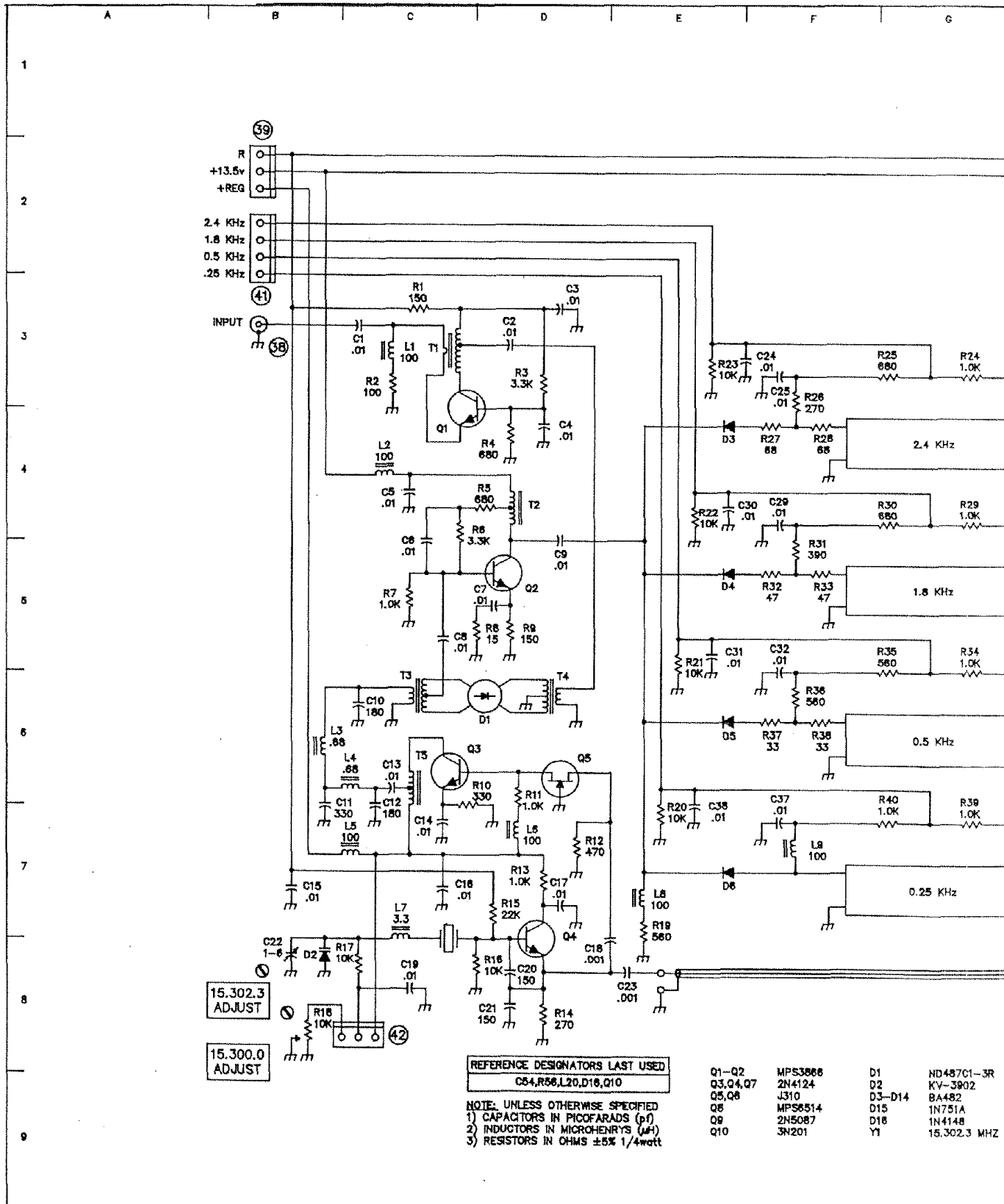

REFERENCE DESIGNATORS LAST USED
 C54, R56, L20, D16, Q10

NOTE: UNLESS OTHERWISE SPECIFIED
 1) CAPACITORS IN PICO FARADS (pf)
 2) INDUCTORS IN MICROHENRYS (μH)
 3) RESISTORS IN OHMS ±5% 1/4watt

Q1-Q2	MPS3866	D1	ND487C1-3R
Q3, Q4, Q7	2N4124	D2	KV-3902
Q5, Q6	J310	D3-D14	BA482
Q8	MPS6514	D15	1N751A
Q9	2N5087	D16	1N4148
Q10	3N201	Y1	15.302.3 MHz

6-7 IF / AF BOARD (81462)

The IF/AF board contains the 9 MHz IF amplifier stages that contribute the major portion of the receiver gain. It also contains the SSB/CW detectors, AGC circuits, audio notch and bandpass filters, audio amplifier, and speaker driver.

The 9 MHz IF signal from the passband tuning board enters at connector 43 and is amplified by grounded gate FET Q1, integrated circuit IF amplifiers U1 and U2, and emitter follower Q2. The output of Q2 splits two ways. One output drives AGC detector D4-D5, to develop an AGC voltage across capacitor C39. Through connector 49, the front panel AGC FAST/SLOW switch connects additional AGC holding capacitor C40 in parallel with C39 in the SLOW position, and the AGC ON/OFF switch shorts the AGC voltage to ground in the OFF position. U9b amplifies and level shifts the AGC voltage and, through D8, applies it to the gain control pins of U1 and U2 and the base of PIN diode driver Q3. Shunt PIN diode D1 attenuates the IF signal at the input to U1 when the amplified AGC voltage exceeds the threshold set by zener diode D2. The front panel RF GAIN control at connector 50 can reduce receiver gain by raising the AGC control line voltage through Q5 and D12.

The AGC voltage across C39 is also amplified and level shifted by S-meter amplifier U9a and split two ways: to the S-meter through D10 and R45, and to the squelch circuit Q6-Q7, Q9. In the squelch circuit, the output of U9a is compared to the voltage across the front panel SQUELCH control at connector 50. When the output of U9a is less than the voltage set by the SQUELCH control at the base of Q6, Q9 and D9 are forward biased, saturating audio clamp transistor Q10, and muting the receiver audio. A mute voltage from control board connector 44 also saturates Q10 during transmit and for a short period after transmit as

determined by C57-C58-R77 and the front panel QSK switch at connector 48.

Another output from Q2 is via C20 to product detector U3. The approximately 9 MHz BFO input to the product detector comes from the transmit audio/BFO board via connector 46. The detected SSB/CW/FSK output from the product detector is filtered by C26, C27, and R17 and applied to a section of audio switch U4.

Based on inputs from the control board on connector 51, audio switch U4 selects an audio signal from the product detector in SSB/CW/FSK mode or the FM option board at connector U in FM mode. The output of U4 drives notch filter circuit U5. The frequency of the audio notch is determined by the clock frequency input to U5 which is developed by notch clock circuit U6. The frequency of notch clock U6 is set by the front panel NOTCH control via connector 53. The frequency range of the notch clock is approximately 27-210 KHz resulting in an audio notch frequency range of 540-4200 Hz. The output of notch filter U5 drives the audio bandpass filter circuits U7 and U8 through C36, and one side of the front panel FADE control through C37 and connector 55. Q8 samples a portion of this "flat" audio and outputs it to the rear panel AUDIO OUT jack via connector 56 and the transmit audio board.

The center frequency of the audio bandpass filter is determined by the voltage applied to R59 and R72 by the front panel BP control via connector 54. The center frequency range of the bandpass filter is approximately 220-1700 Hz, and the 6 dB bandwidth is always 35% of the center frequency. Bandpass filtered audio output from U8 is routed to one side of the front panel FADE control through C46 and connector 55.

On the upper pot board, the unfiltered (flat) audio from C37 and the bandpass filtered audio from C46 are combined in proportions determined by the setting of the front panel

FADE control. Clockwise rotation of the control increases the filtered portion and decreases the unfiltered portion of audio delivered to audio amplifier U10a through connector 55, R79 and C51. When the squelch is "closed", clamp transistor Q10 is saturated, shunting all receiver audio to ground. Unsquelched receive audio (or transmit audio from sidetone connector 57) is amplified by U10a and applied to the clockwise end of the front panel TONE control via connector 55. The counter-clockwise end of the control

returns through connector 55 to the input of speaker driver U10b. C48 shunts the wiper of the control to ground, forming a "high-cut" tone control. Cable 47 connects the speaker driver output to the front panel PHONES jack and the rear panel EXT SPKR jack. Cable 76 carries it from there to the sidetone board, cable 77, and the internal speaker.

Cable 55/45 from the control board supplies +13.5 Volt power to U10 and "+REG" to all remaining circuitry.

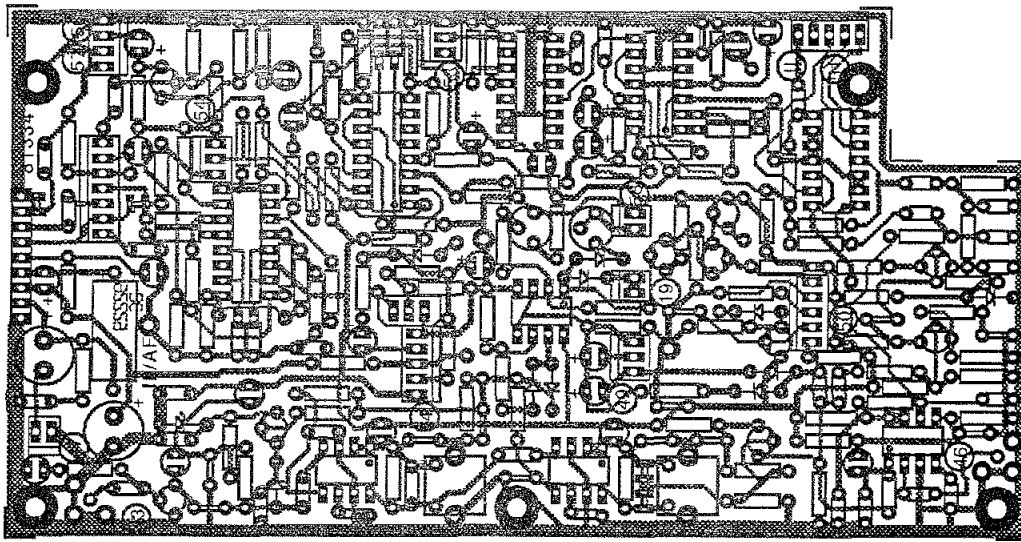

FIGURE 6-17. 81462 IF / AF BOARD CIRCUIT TRACE

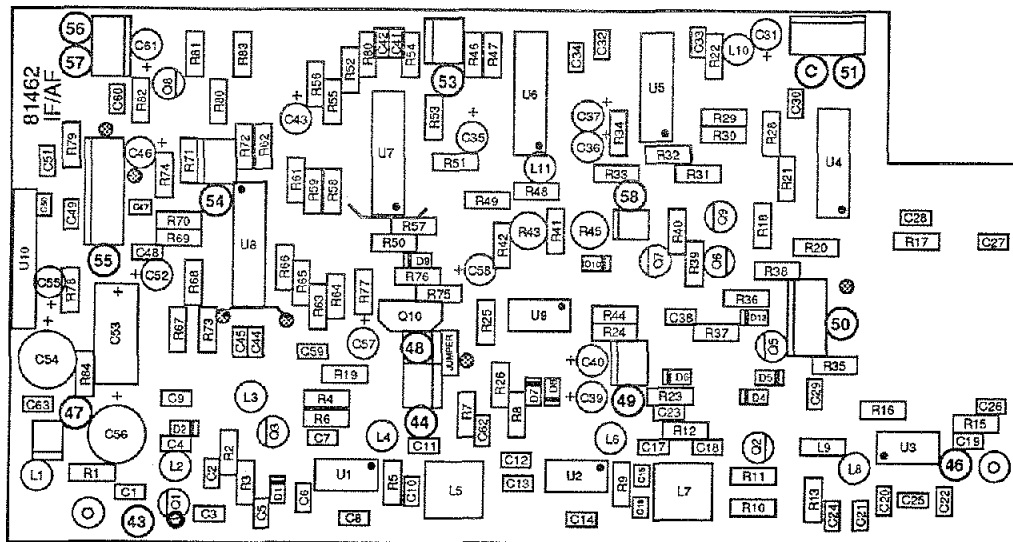
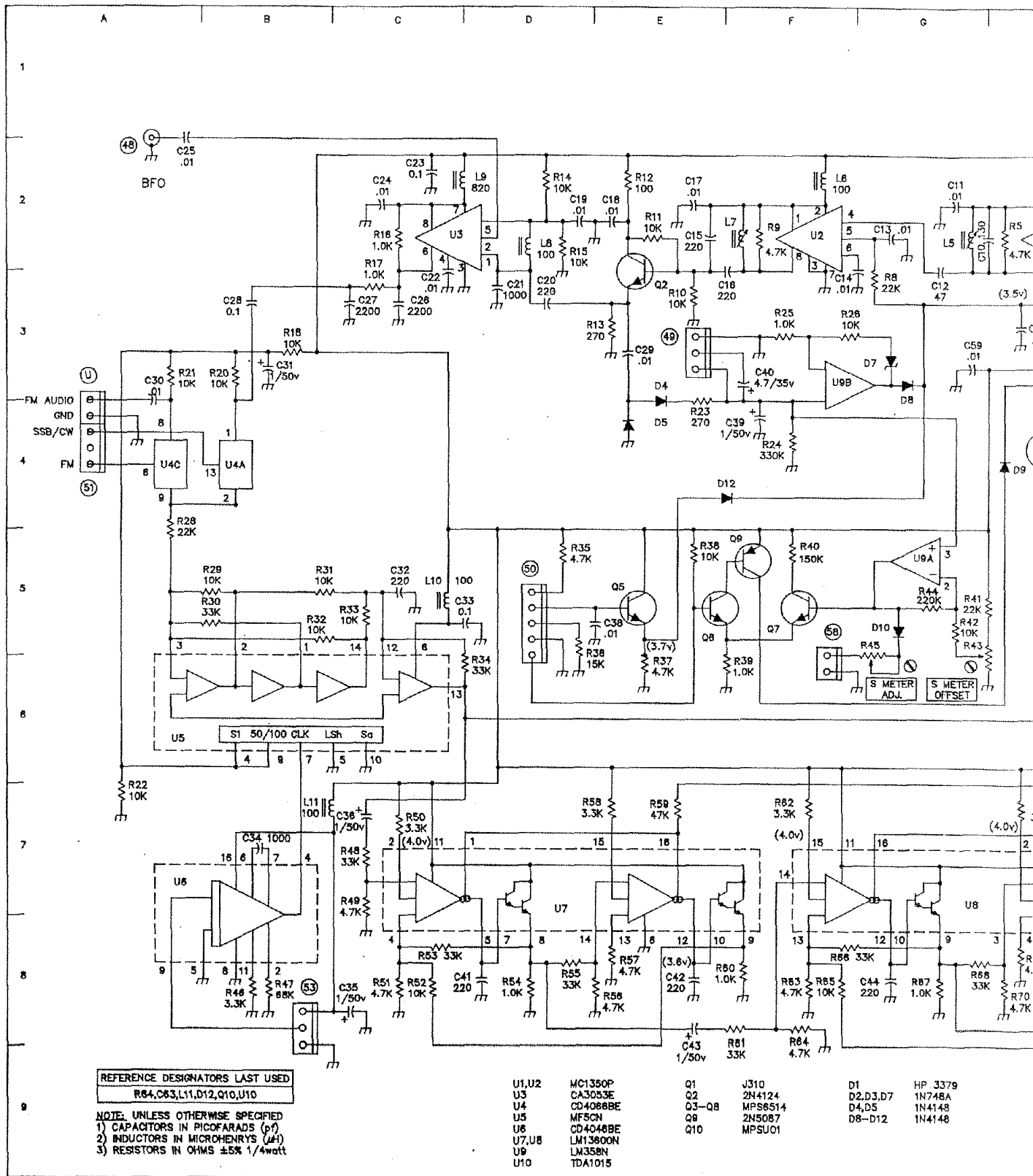

FIGURE 6-18. 81462 IF / AF BOARD COMPONENT LAYOUT



REFERENCE DESIGNATORS LAST USED
R64, C63, L11, D12, Q10, U10

NOTE: UNLESS OTHERWISE SPECIFIED
1) CAPACITORS IN PICO FARADS (PF)
2) INDUCTORS IN MICROHENRYS (UH)
3) RESISTORS IN OHMS ±5% 1/4WATT

U1, U2	MC1350P	Q1	J310	D1	HP 3379
U3	CA3053E	Q2	2N4124	D2, D3, D7	1N748A
U4	CD4068BE	Q3-Q8	MPS6514	D4, D5	1N4148
U5	MF5CN	Q9	2N5087	D8-D12	1N4148
U6	CD4048BE	Q10	MPSU01		
U7, U8	LM13800N				
U9	LM358N				
U10	TDA1015				

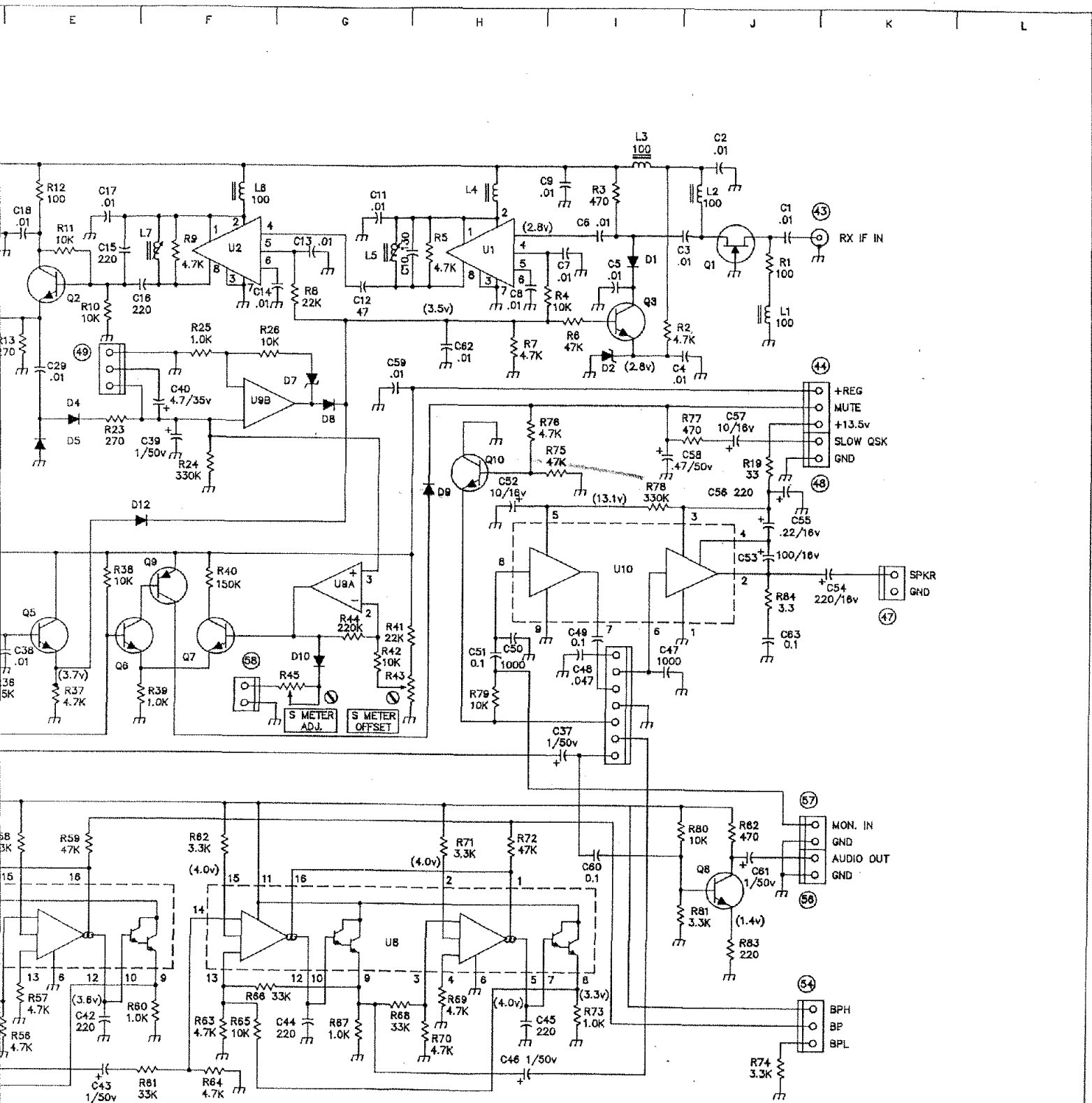

Q1	J310	D1	HP 3379
Q2	2N4124	D2, D3, D7	1N748A
Q3-Q8	MPS8514	D4, D5	1N4148
Q9	2N5087	D8-D12	1N4148
Q10	MPS001		

FIGURE 6-19 IF/AF 81462

A B C D E

1
2
3
4
5

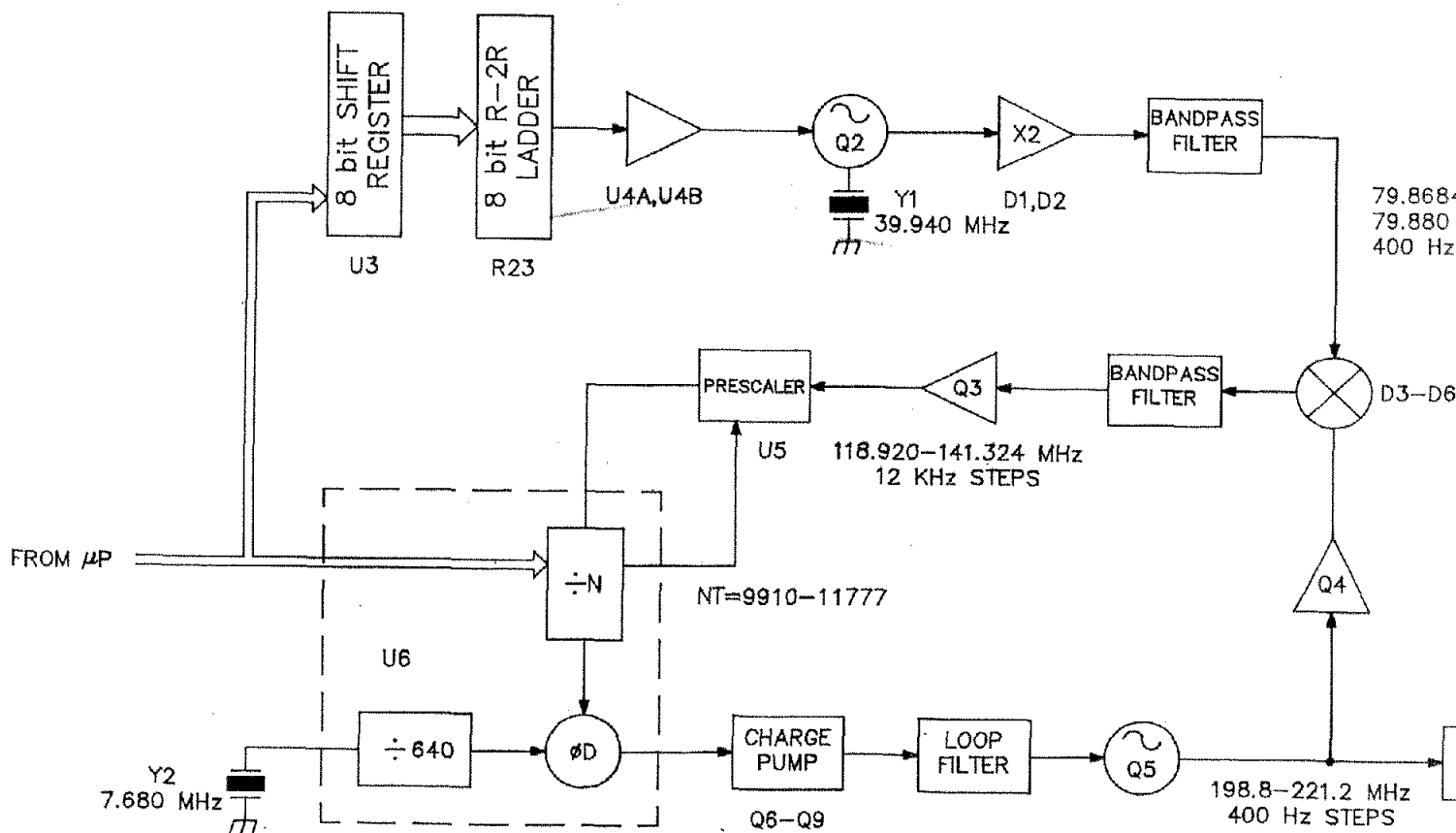

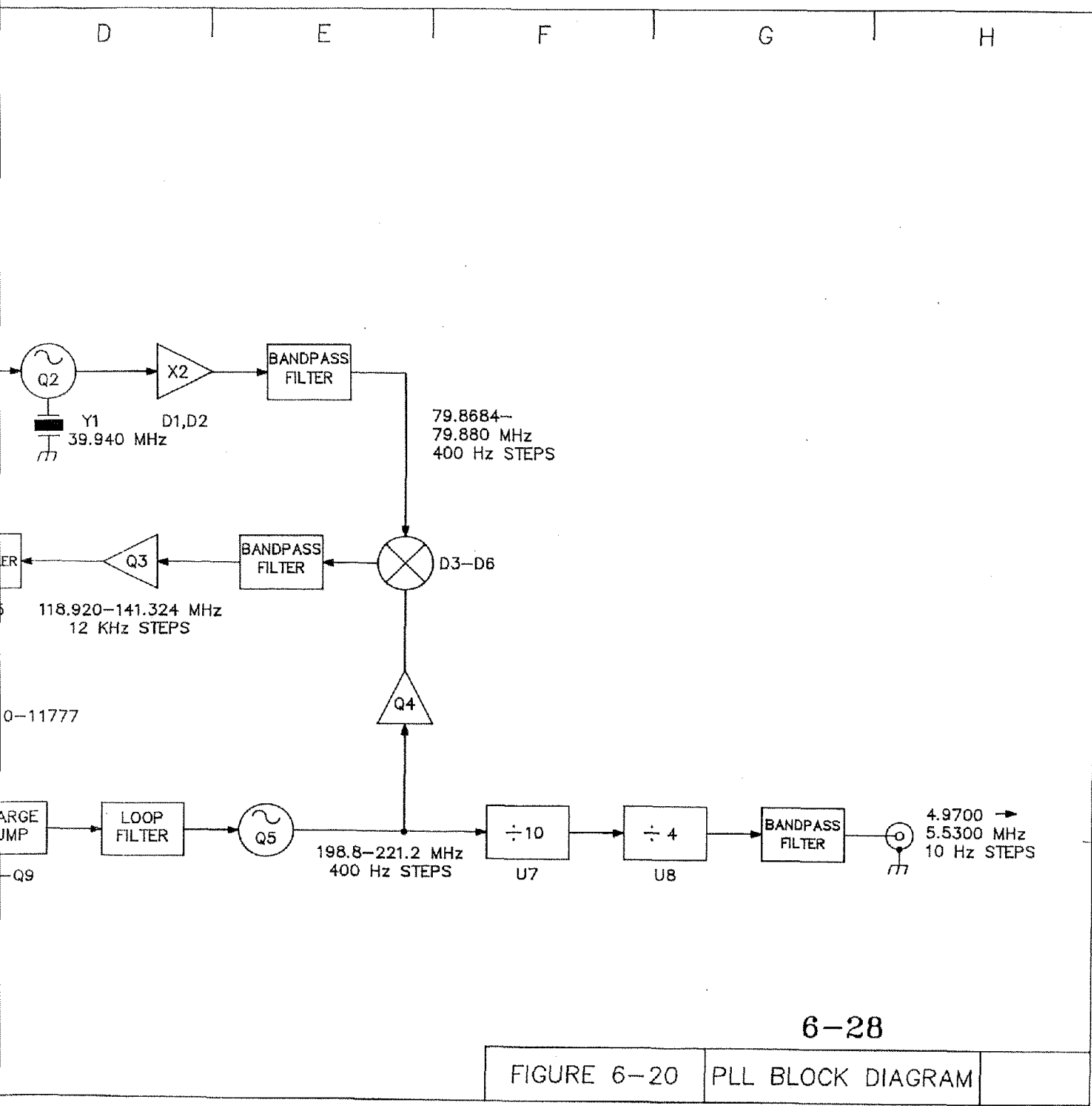

6-28

FIGURE 6-20 PLL BLOCK DIAGRAM

6-8 PHASE LOCKED LOOP BLOCK DIAGRAM

As shown in FIGURE 6-20, the OMNI V uses a two loop synthesizer system. The heart of the system is integrated circuit U6, a programmable PLL synthesizer. Crystal Y2 provides a reference frequency of 7.680 MHz which divided by 640 to yield a loop reference frequency of 12 kHz. This reference signal is applied to one input of an internal phase detector in U6. The other input to the phase detector comes from a programmable divide-by-N counter also in U6. This counter is serially programmed by a microprocessor located on the logic board. The microprocessor also sends 8 bits of serial data to U3, a static shift register. The output of U3 goes to an 8 bit R-2R resistor network R23 which forms a simple D-to-A convertor. U4A and U4B buffer the analog output from the resistor network before being applied to VCXO Q2. The output from Q2 is then double by D1,D2 and filtered by a bandpass filter before going to mixer D3-D6. The output frequency of the VCXO is 79.8684 to 79.880 MHz in 400 Hz steps. The phase detector output is applied to the charge pump Q6-Q9 and then through a low pass filter and on to VCO Q5. The VCO frequency ranges from 198.8 to 221.2 MHz and tunes in 400 Hz steps. This VCO signal is sent to mixer D3-D6 which combines the VCO and VCXO signals to yield a difference signal in the range of 118.920 to 141.324 MHz. This is then applied to prescaler U5 which divides it down before finally being sent to the divide-by-N counters in U6. The VCO output is also divided by 40 in U7, U8 and filtered before being output to other circuits in the OMNI V. The resulting output signal ranges from 4.970 to 5.530 MHz tuned in 10 Hz steps.

6-9 5.0-5.5 MHZ PLL BOARD (81459)

The phase noise characteristics of the OMNI V depend entirely on the design of the 5.0 - 5.5 MHz synthesizer. The synthesizer is actually a two loop system that operates at 200 to 220 MHz and tunes in 400 Hz steps. Its output is then divided by 40 to produce the desired 5.0 to 5.5 MHz output. This division by 40 not only reduces the output frequency but also reduces phase noise and spurious levels by a factor of 32 dB.

The synthesizer's 10 Hz tuning resolution is derived from a voltage controlled crystal oscillator (VCXO) Y1, Q2. Digital information from the microprocessor is clocked in serially at connector 84 and loads the shift register chip U3. The 8 bit output of U3 is applied to an R-2R resistor network, R23, which is used to provide digital-to-analog conversion of the outputs of U3. U4A and U4B buffer the analog output from the resistor network and provide gain and offset adjustments (R27 and R31) to align the frequency of the VCXO.

The VCXO output from Q2 is doubled by T2, D1 and D2, and then heavily filtered before it drives the diode mixer in the feedback path of the main loop. The mixer D3-D6 subtracts the VCXO frequency from the main loop's output which has been buffered by Q4. This difference signal becomes the feedback for the main loop. Q3 is a filtered amplifier stage which boosts the mixer output to a level sufficient to drive the prescaler chip U5. Since the loop works to keep this feedback signal constant in frequency, the small steps from the VCXO are imposed onto the main loop output.

Reference and $\div N$ dividers in PLL chip U6 are programmed serially from the microprocessor through connector 84. Y2, the 7.680 MHz reference oscillator crystal is divided internally in U6 by 640 to generate a 12 kHz step size. Phase errors from the PLL's phase detector steer the charge pump circuit Q6-Q9.

The VCO control voltage from the charge pump is low pass filtered and biases varicap diodes D9 and D10. The VCO output is applied to a two way splitter comprised of T5 and R49, and drives both the mixer buffer stage Q4 and the high speed $\div 10$ chip U7. The output of U7, a square wave of 20 - 22 MHz, clocks a $\div 4$ circuit in U8. The 5.0 to 5.5 MHz signal from U8 is then filtered to remove harmonics and exits to the LO mixer board at connector 85.

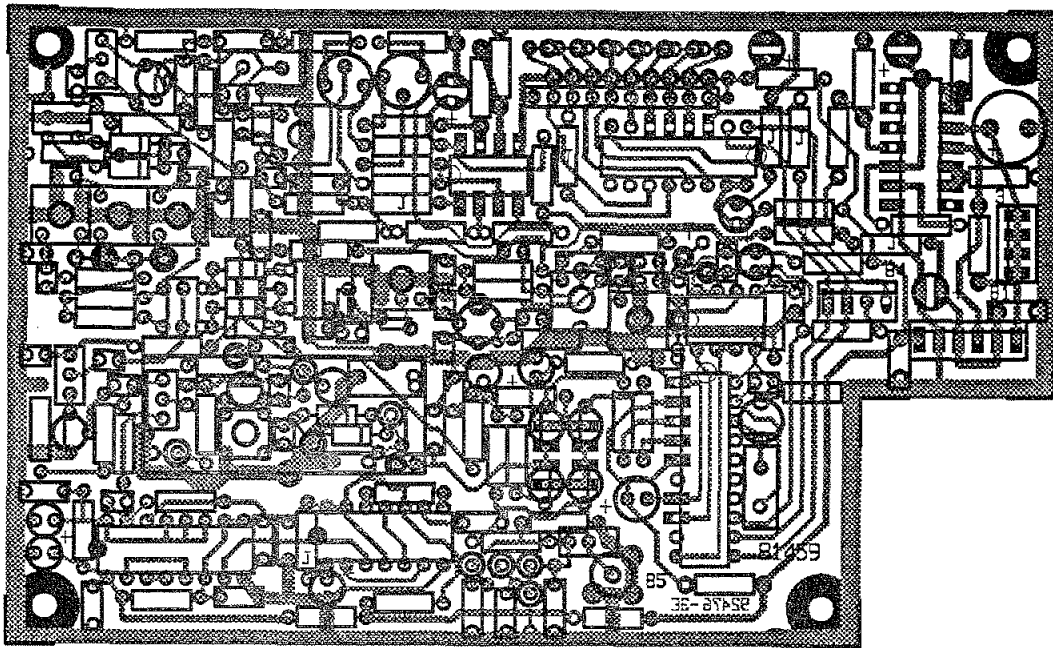

FIGURE 6-21. 81459 5.0-5.5 MHZ PLL BOARD CIRCUIT TRACE

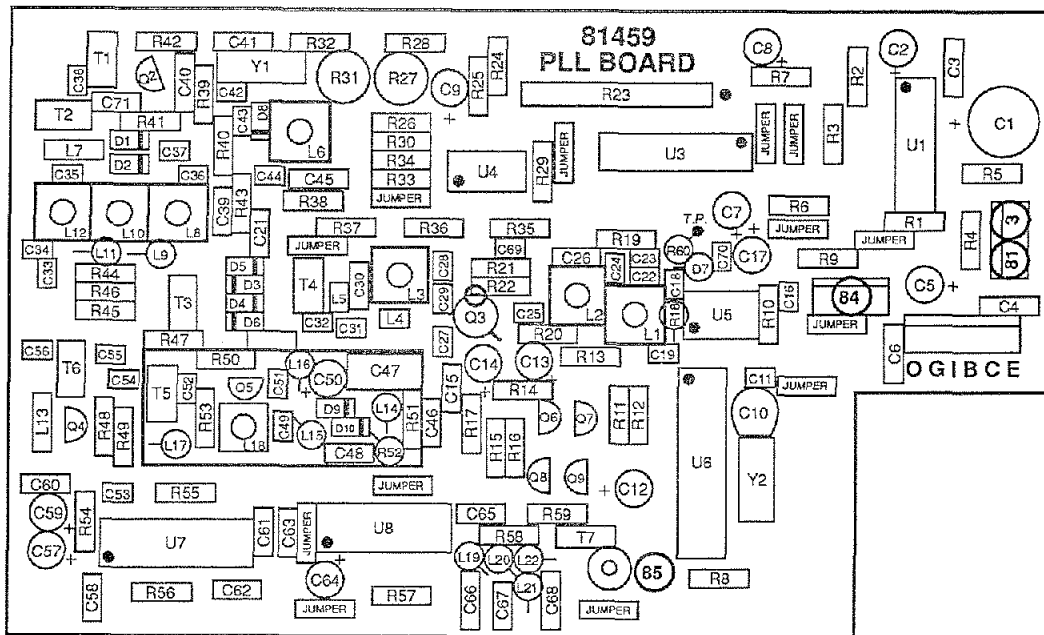
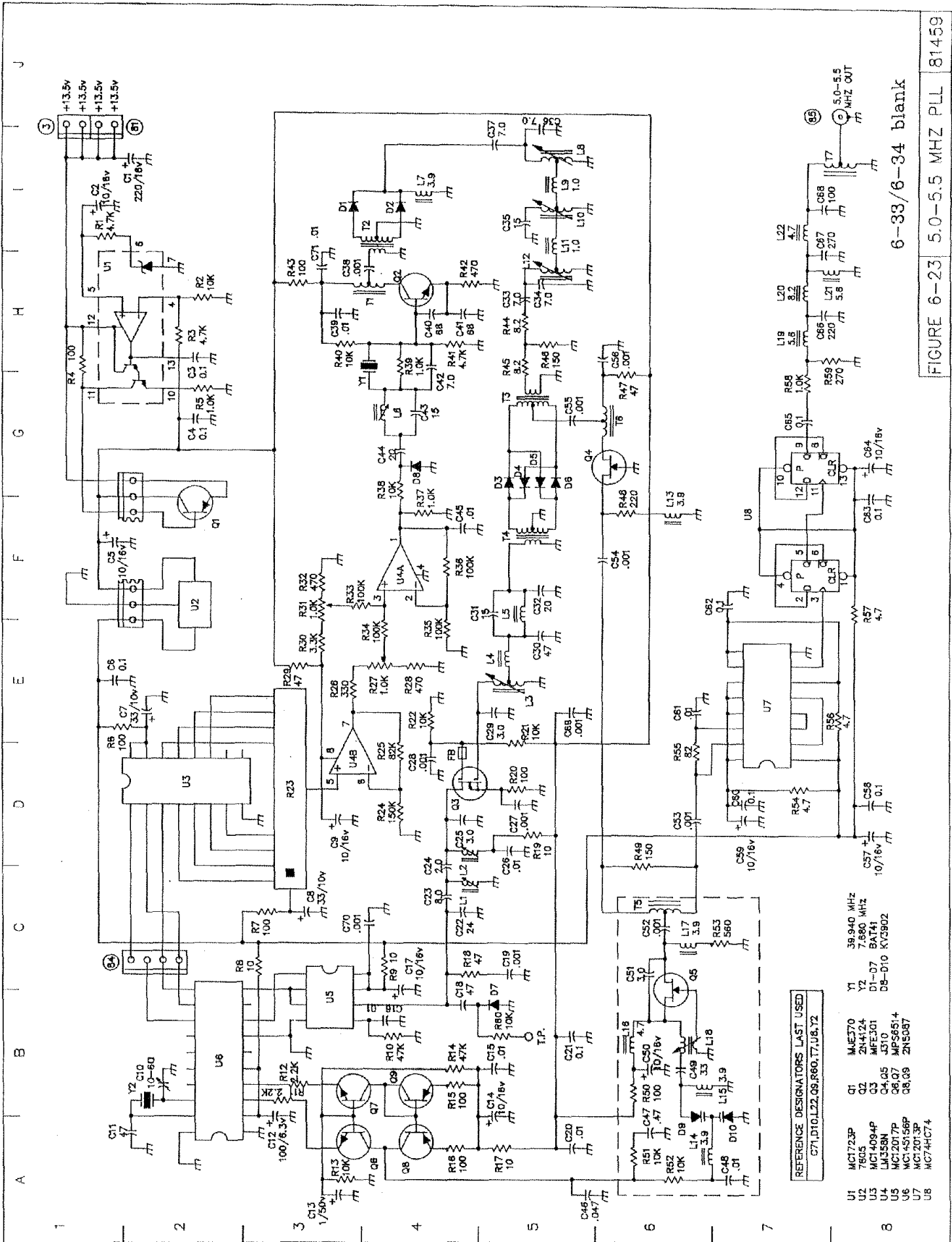

FIGURE 6-22. 81459 5.0-5.5 MHZ PLL BOARD COMPONENT LAYOUT



REFERENCE DESIGNATORS LAST USED

C71, D10, L22, Q9, R60, T7, U8, Y2

U1	MCT723P	Q1	MAE370	Y1	39.940 MHz
U2	7805	Q2	2N4124	Y2	7.880 MHz
U3	MCT4094P	Q3	MFE301	D1-D7	BAT41
U4	LM358N	Q4, Q5	5310	DB-D10	KV3902
U5	MCT2017P	Q6, Q7	MPS4514		
U6	MCT45156P	Q8, Q9	2N5087		
U7	MCT2013P				
U8	MCT74HC74				

FIGURE 6-23 5.0-5.5 MHz PLL 81459

6-33/6-34 blank

6-10 CONTROL BOARD (81456)

This board contains diode and transistor logic circuitry to develop control voltages based on inputs from the logic board, rear panel control jacks, or front panel switches, that determine the mode of operation (SSB, CW, transmit, receive, etc.) of the various circuits in the transceiver. It also contains the adjustable CW wave shaping circuit that sets the rise and fall times of the transmitted CW envelope, and the hold-in adjustment for the auxiliary T/R relay.

The main mode information from the microprocessor enters at connector 59. "T" voltage (indicating transmit mode) enters at connector 61 from the low level amplifier board. These inputs are combined in diode-transistor logic circuits D1-D11, D28-D29 and Q3-Q9 to form mode outputs to the IF/AF and transmit audio boards via connectors 51 and 60.

A request to key the transmitter is generated by grounding the PTT (rear panel or microphone/VOX via switch board connector 65 or CW KEY lines, or a TUNE output from the logic board, which forward biases Q1, Q2, or D18, sending a high level to the microprocessor via connector 66 and, via D25 to the mute pin of IF/AF connector 45. The microprocessor buffers the transmit request and drives Q13, pulling the center pin of the rear panel TX OUT connector to ground. Normally the TX OUT connector is jumpered to the TX ENable connector and the low level from Q13 is passed directly to keying waveshape circuit Q14-Q17. An external keying interlock loop may be substituted for the jumper between TX OUT and TX ENable. Such an interlock may be used to prevent "hot switching" of a QSK linear amplifier, for example.

The keying waveshape circuit Q14-Q17 is an adjustable integrator that slows down the rise and fall times of the keying voltage "TD" which is sent to the T/R generator on the low

level amplifier board via connector 61, and to the balanced modulator on the TX audio board via connector 60. CW waveshape adjustment R27 sets the keying rise and fall times in the range of 1-5 mS. This waveshaping has little effect on the T/R generator since its switching threshold is below 1 Volt. The balanced modulator, however, has a more gradual increase in gain as "TD" goes high, thus transferring the slowed rise and fall times to the transmitted keying waveform.

The buffered transmit request signal from the microprocessor at connector 66 also drives control relay RLY 1 via D20 and Q18 to provide a ground at the center pin of the rear panel RLY OUT connector during transmit. In CW mode, Q12 connects C8 into the circuit to hold Q18 and RLY 1 on between dits. This hold-in time is adjusted by the board mounted DELAY ADJUST pot R32.

An output from the collector of CW/FSK keying transistor Q2 passes through R37, R18 and connector 63 to activate the CW oscillator on the board. Transistor Q10 clamps this output to ground to prevent generation in FSK mode.

Cables 61/62, 40/39, 10/9, 21/20, 36/35, 45/44, and 5 distribute T, R, +REG, and +13.5 Volts to several boards. Wires in these cables are color coded as follows: T - blue, R - yellow, +REG - orange, +13.5 - red .

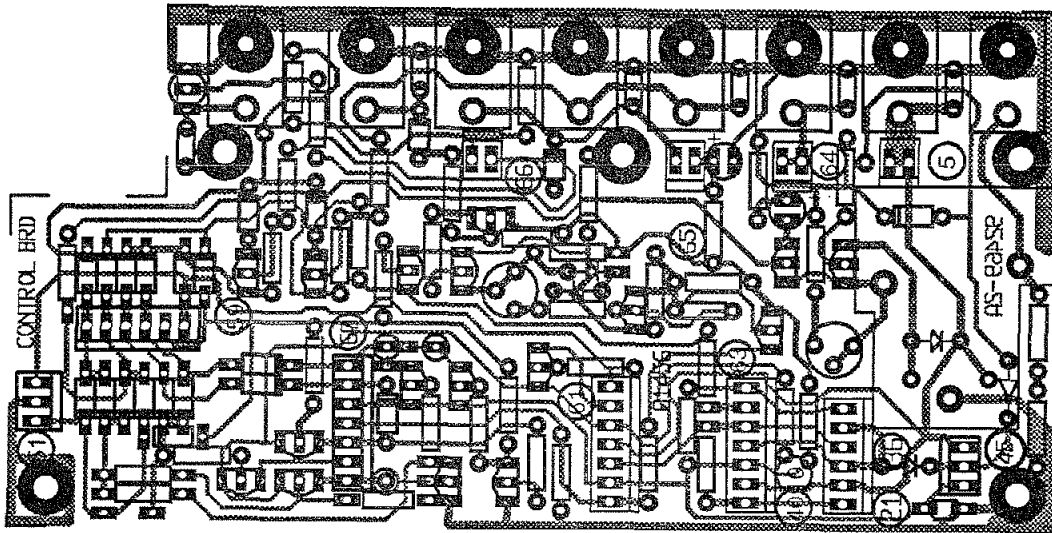

FIGURE 6-24. 81456 CONTROL BOARD CIRCUIT TRACE

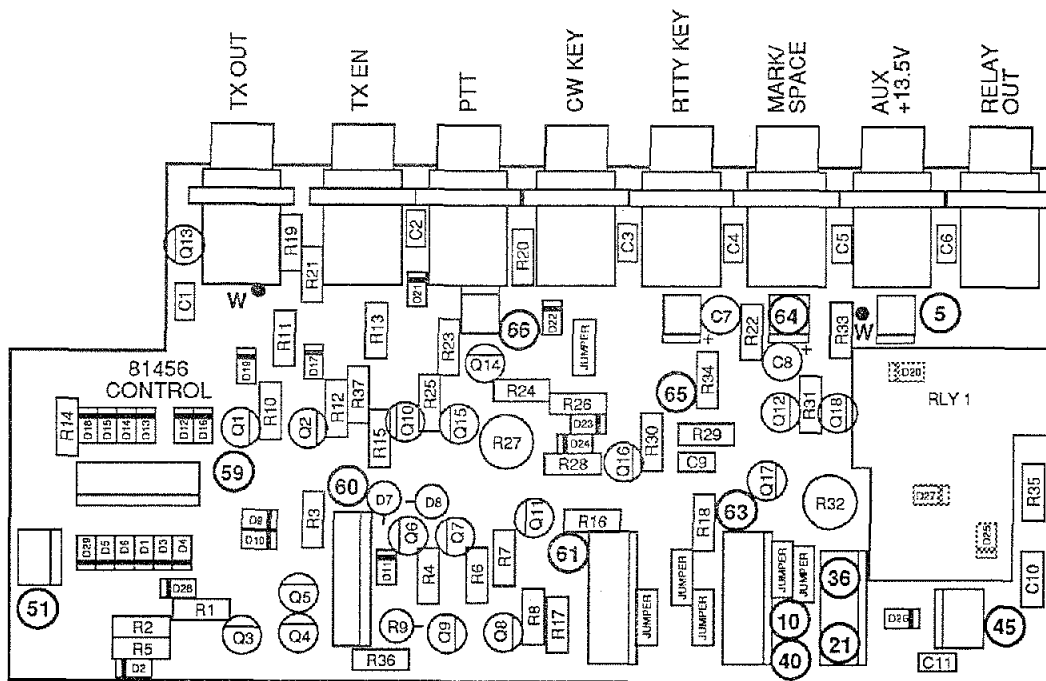
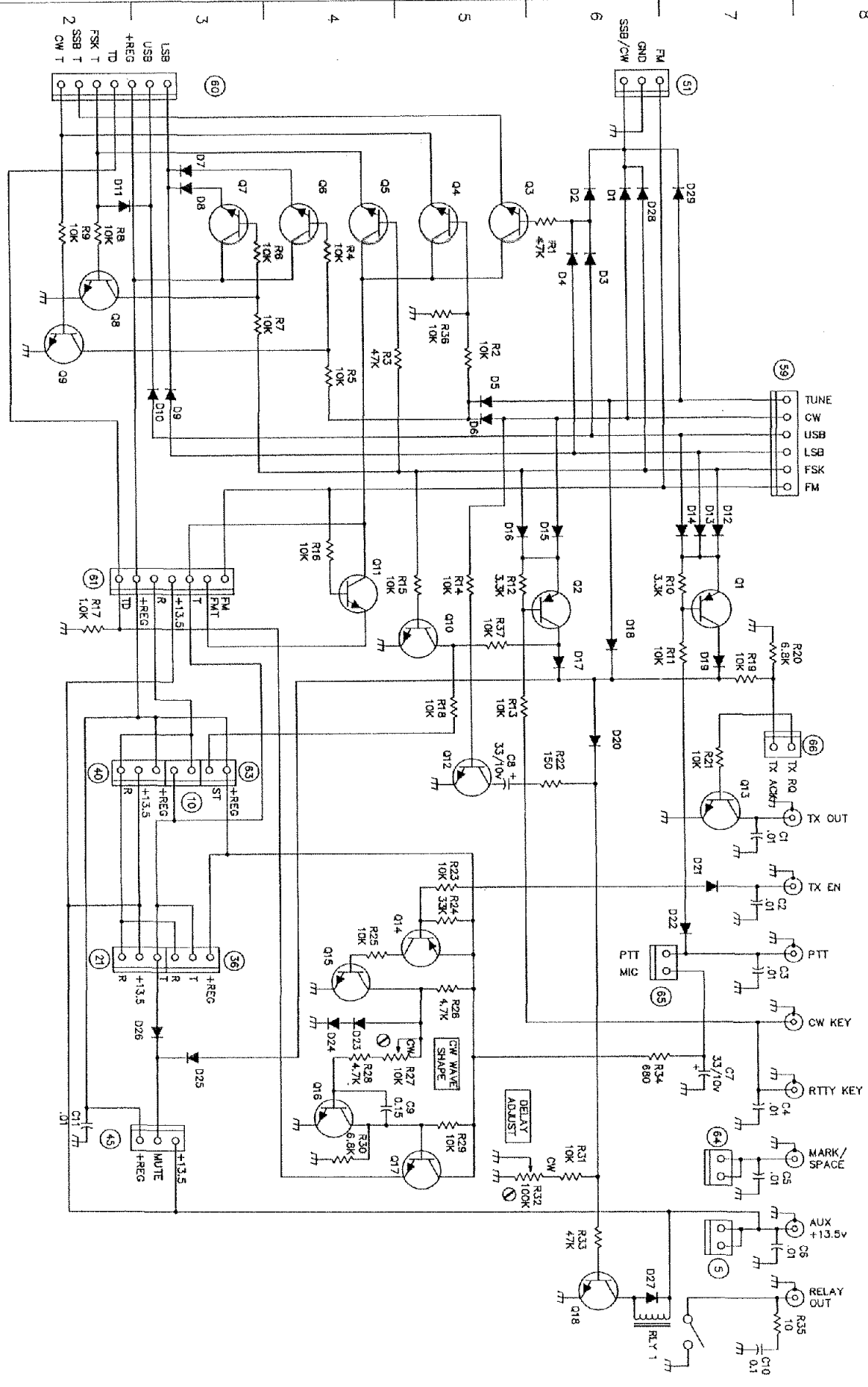

FIGURE 6-25. 81456 CONTROL BOARD COMPONENT LAYOUT



REFERENCE DESIGNATORS LAST USED
 R37, C11, D29, Q18

NOTE: UNLESS OTHERWISE SPECIFIED
 1) CAPACITORS IN PICOFARADS (PF)
 2) INDUCTORS IN MICROHENRYS (UH)
 3) RESISTORS IN OHMS ±5% 1/4W

Q1, Q2, Q14
 Q3-Q13, Q15-Q17
 Q18
 D1-D29
 ZN5087
 MP96514
 MP5A13
 IN4148

FIGURE 6-26 6-37/6-38 blank CONTROL BOARD 81456

6-11 SWITCH BOARD (81327)

The switch board contains five latching pushbutton switches which control the functions of Noise Blanker, VOX/PTT, QSK slow/fast, AGC on/off, and AGC fast/slow. This assembly is mounted on the left front subpanel just inboard of the main power switch.

Through connector 67, NB switch S1 feeds regulated voltage to the noise blanker pulse amplifier on the low level amplifier board enabling the noise blanker function.

VOX/PTT switch S2 selects the keying source to be sent to the control board via connector 65. Connector 69 carries the push to talk line and microphone polarizing voltage from the front panel MIC connector. The polarizing voltage loops directly to the control board connector 65, and the PTT line is switched to the control board when S2 is in the PTT position. When S2 is in the VOX position, the VOX output from the TX audio/BFO board at connector 68 is switched to connector 65 and the control board keying circuit.

In the slow position, QSK fast/slow switch S3 increases the recovery time of the mute circuit on the IF/AF board by connecting in additional capacitance via connector 48.

AGC off/on switch S4 disables the AGC circuit on the IF/AF board by grounding the AGC amplifier input through connector 49.

AGC fast/slow switch S5 increases the AGC decay time in the slow position by grounding the bottom end of an additional integrating capacitor in the AGC circuit.

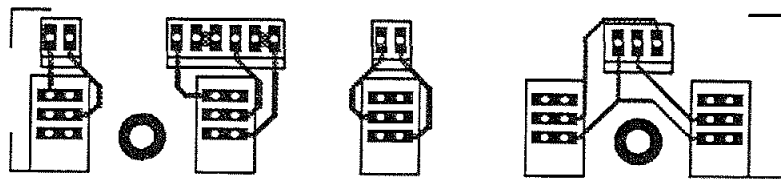

FIGURE 6-27. 81327 SWITCH BOARD CIRCUIT TRACE

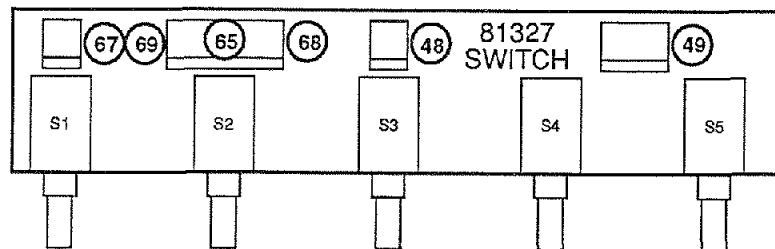

FIGURE 6-28. 81327 SWITCH BOARD COMPONENT LAYOUT

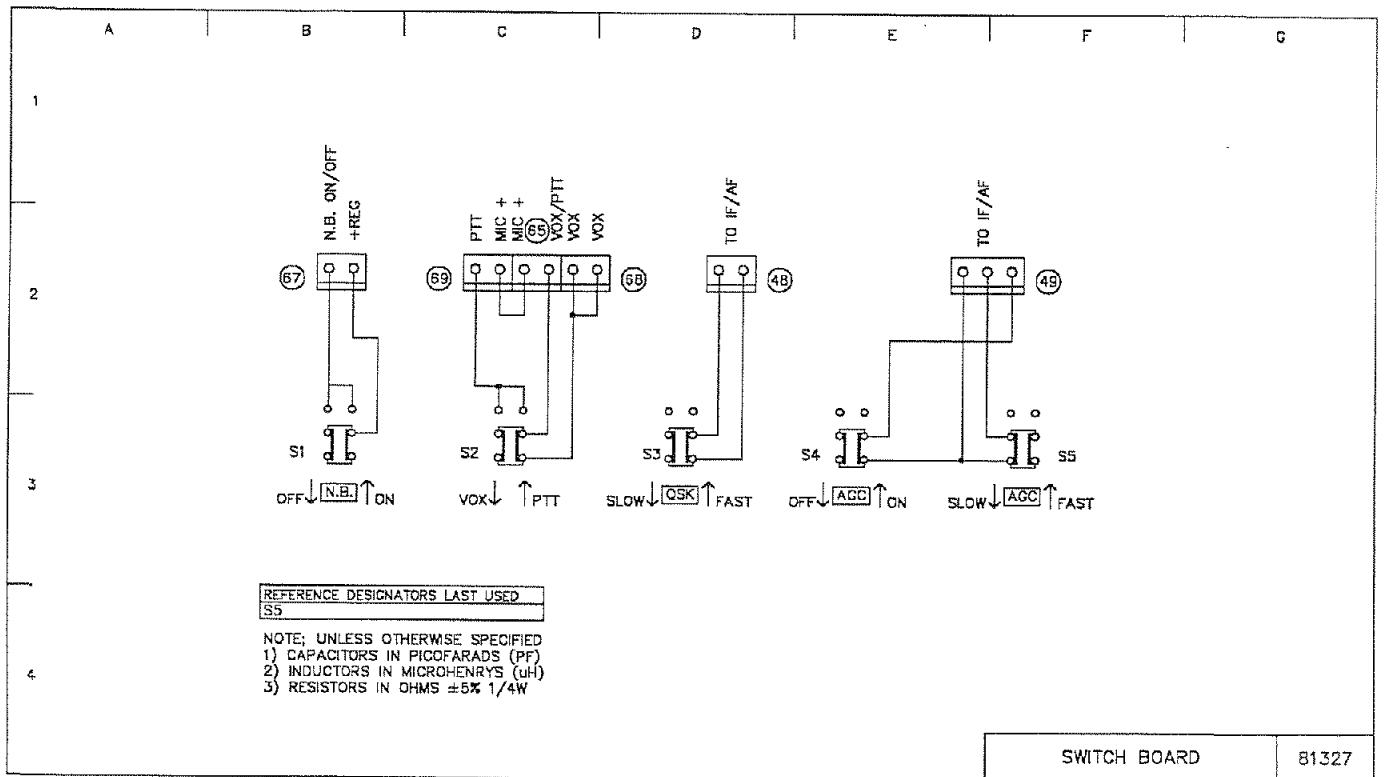

FIGURE 6-29. 81327 SWITCH BOARD SCHEMATIC

6-12 UPPER POT BOARD (81326)

This assembly contains three dual concentric controls, a latching pushbutton switch and an LED indicator. The board mounts on the left front sub panel at the control positions of AFGAIN and TONE, FADE and BP FILTER, PBT and NOTCH, and the ATTN switch.

The ATTN switch S1 is wired to the Xtal Osc-LO Mixer board by connector 18 where it controls the insertion of the receiver attenuator pad. When the pad is inserted, S1 applies 13.5 Volts to the anode of -20 dB indicator LED D1 which supplies a forward current through connector 18 to a dropping resistor on the Xtal Osc-LO Mixer board.

The AF GAIN control R5 forms a voltage divider at the output of fader network R1-R4 and R7 to select a controlled amount of audio signal for input to the audio amplifier on the IF/AF board via connector 55.

Unfiltered and filtered audio from the IF/AF board and connector 55 drive fader network resistors R1 and R2 respectively. The wiper of FADE control R7 is grounded through the center pin of connector 55 forming proportional voltage dividers with R1 and R2. The filtered and unfiltered portions are added together at the AF GAIN control R5 by summing resistors R3 and R4. Clockwise rotation of R7 increases the filtered portion and decreases the unfiltered portion of audio delivered to R5.

BP FILTER control R8 sets a dc voltage which determines the center frequency of the audio bandpass filter on the IF/AF board via connector 54. Clockwise rotation of the control increases the voltage at the center pin of connector 54 and increases the center frequency of the filter.

TONE control R6 is part of a "high cut" filter circuit between audio stages on the IF/AF board. Clockwise rotation of R6 reduces the amount of high frequency roll off in the receive audio path.

NOTCH control R10, through connector 53 to the IF/AF board, varies a dc voltage to a clock oscillator which determines the frequency of the audio notch filter. Clockwise rotation of R10 increases the voltage at the center pin of connector 53, increasing the notch frequency.

The PBT control R9 connects to the Pass Band Tuning board through connector 42 where it controls the dc bias to the 15.3 MHz pass band tuning VCXO. Clockwise rotation of R9 increases the voltage on the center pin of connector 42, increasing the frequency of the VCXO.

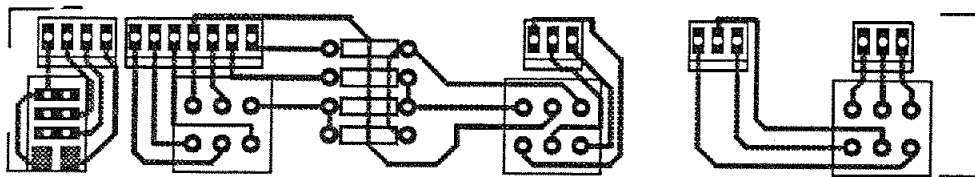

FIGURE 6-30. 81326 UPPER POT BOARD CIRCUIT TRACE

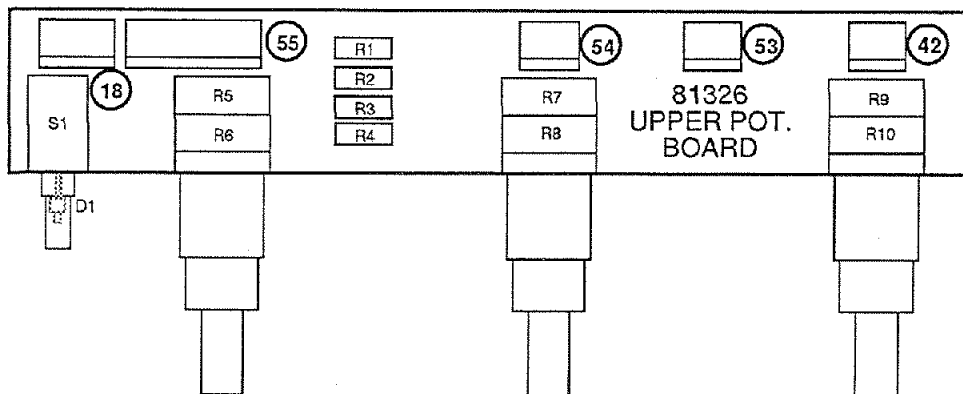

FIGURE 6-31. 81326 UPPER POT BOARD COMPONENT LAYOUT

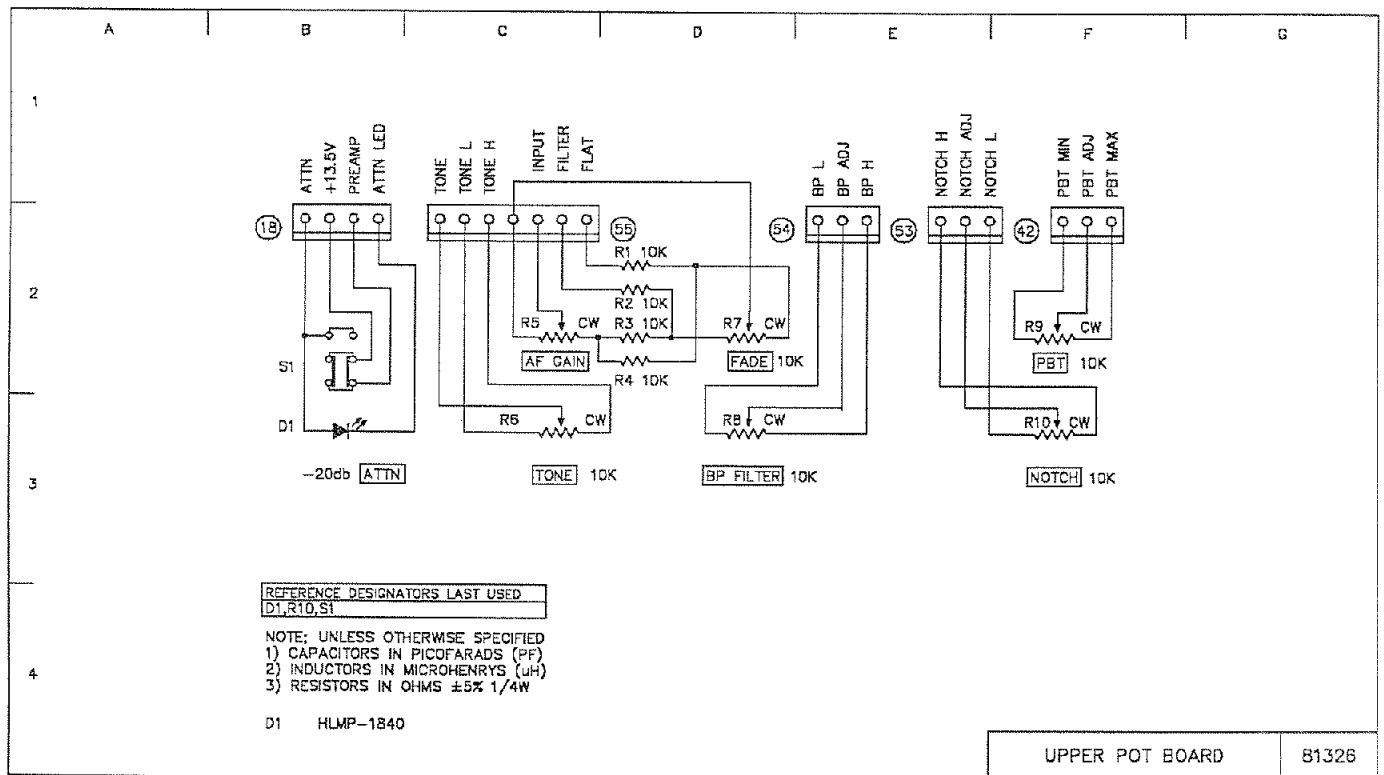

FIGURE 6-32. 81326 UPPER POT BOARD SCHEMATIC

6-13 LOWER POT BOARD (81325)

This board contains two dual concentric controls, a latching pushbutton switch, and two LED indicators. The board mounts on the left front panel at the control positions of MIC/RF PWR, RF gain/SQUelch, ALC indicator, and the PROCessor on/off switch and indicator.

When PROCessor on/off switch S1 is in the "on" position, "+REG" voltage is applied to the anode of LED D1 and, through connector 70, to a diode on the Transmit Audio board which routes processed audio to MIC gain control R1 via cable 71. R1 sets the level of the signal returning on cable 71 to the balanced modulator. When S1 is in the "off" position, indicator D1 is extinguished, and unprocessed transmit audio is routed through R1 to the balanced modulator.

RF PWR control R2 forms a voltage divider, through connector 29 to the 9 MHz Crystal Filter board, which sets the ALC threshold. ALC action develops a current through connector 28 which illuminates ALC indicator D2.

RF gain and SQUelch controls R3 and R4 form voltage dividers, through connector 50 to the IF/AF board, which determine respectively AGC resting voltage and squelch threshold.

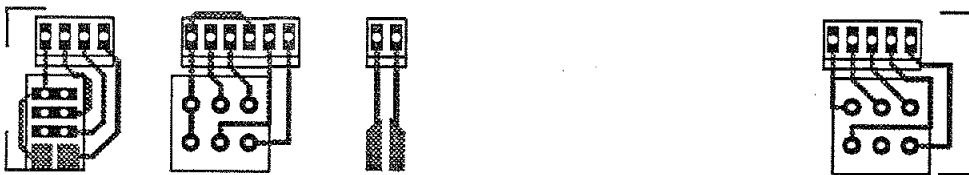

FIGURE 6-33. 81325 LOWER POT BOARD CIRCUIT TRACE

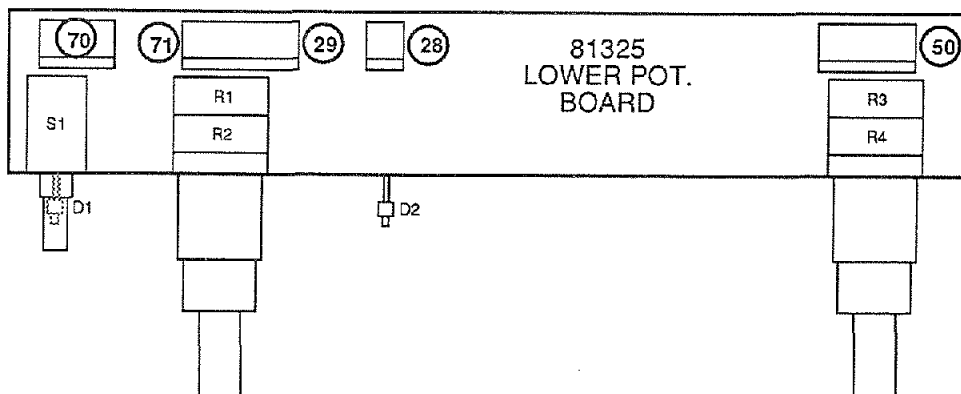

FIGURE 6-34. 81325 LOWER POT BOARD COMPONENT LAYOUT

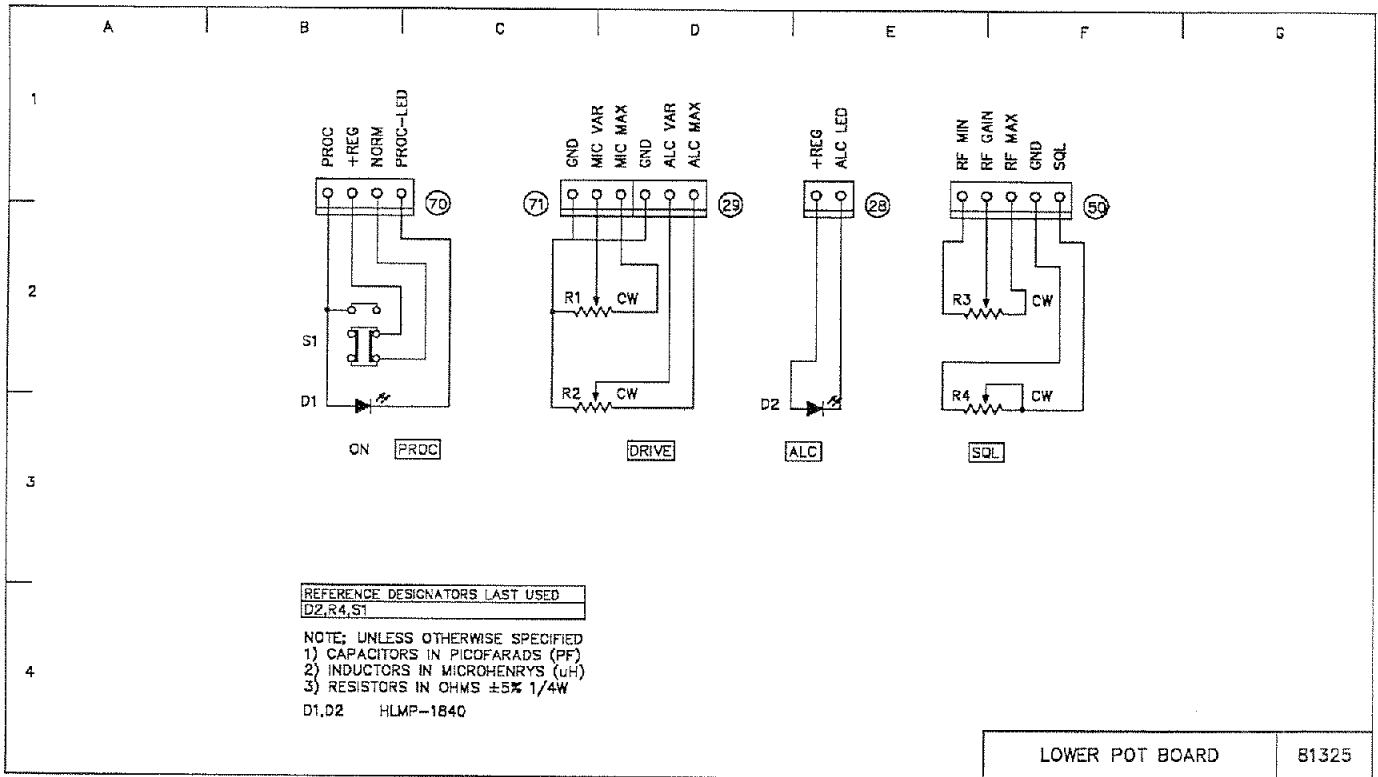

FIGURE 6-35. 81325 LOWER POT BOARD SCHEMATIC

6-14 SIDETONE BOARD (81362)

The sidetone board is mounted on the left rear panel with four controls accessible from the rear. The controls are user adjustable CW sidetone PITCH and LEVEL, transmit audio MONITOR level, and keypad BEEP/VOICE synthesizer level.

Transistor Q2 and associated components form a twin-tee audio oscillator with frequency of oscillation determined by PITCH control R7 and output level set by LEVEL control R10. The oscillator is enabled by transistor Q1 switching emitter bypass capacitor C1 to ground when the sidetone pin of connector 63 from the control board goes high.

MONITOR control R12 receives a sample of the transmit audio signal from the TX Audio/BFO board on connector 72. The BEEP/VOICE control R14 receives keyboard beep and optional voice synthesizer signals from the digital board via connector 80. The outputs from the three level controls are summed by resistors R11, R13, and R15 into an audio amplifier on the IF/AF board via connector 57.

Anti-vox and speaker connections jumper through this board from the external speaker jack at connector 76 to the TX Audio/BFO board via connector 72 and the internal speaker via connector 77.

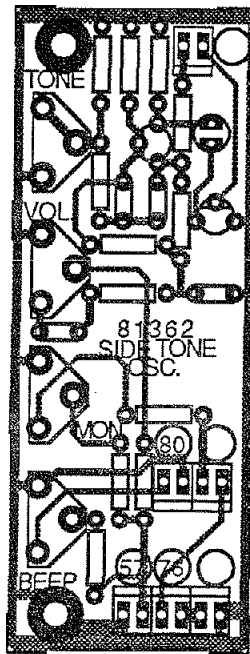

FIGURE 6-36. 81362 SIDETONE BOARD CIRCUIT TRACE

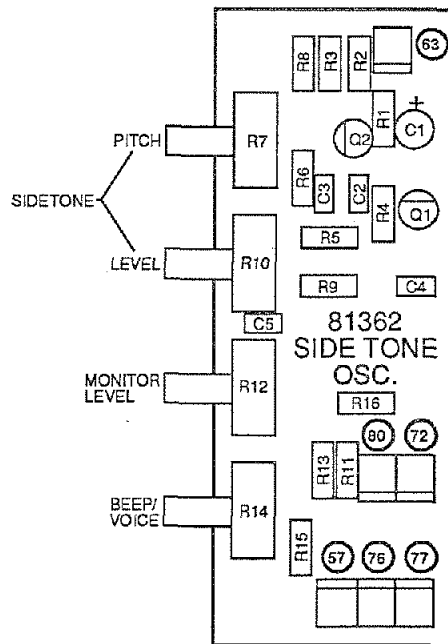

FIGURE 6-37. 81362 SIDETONE BOARD COMPONENT LAYOUT

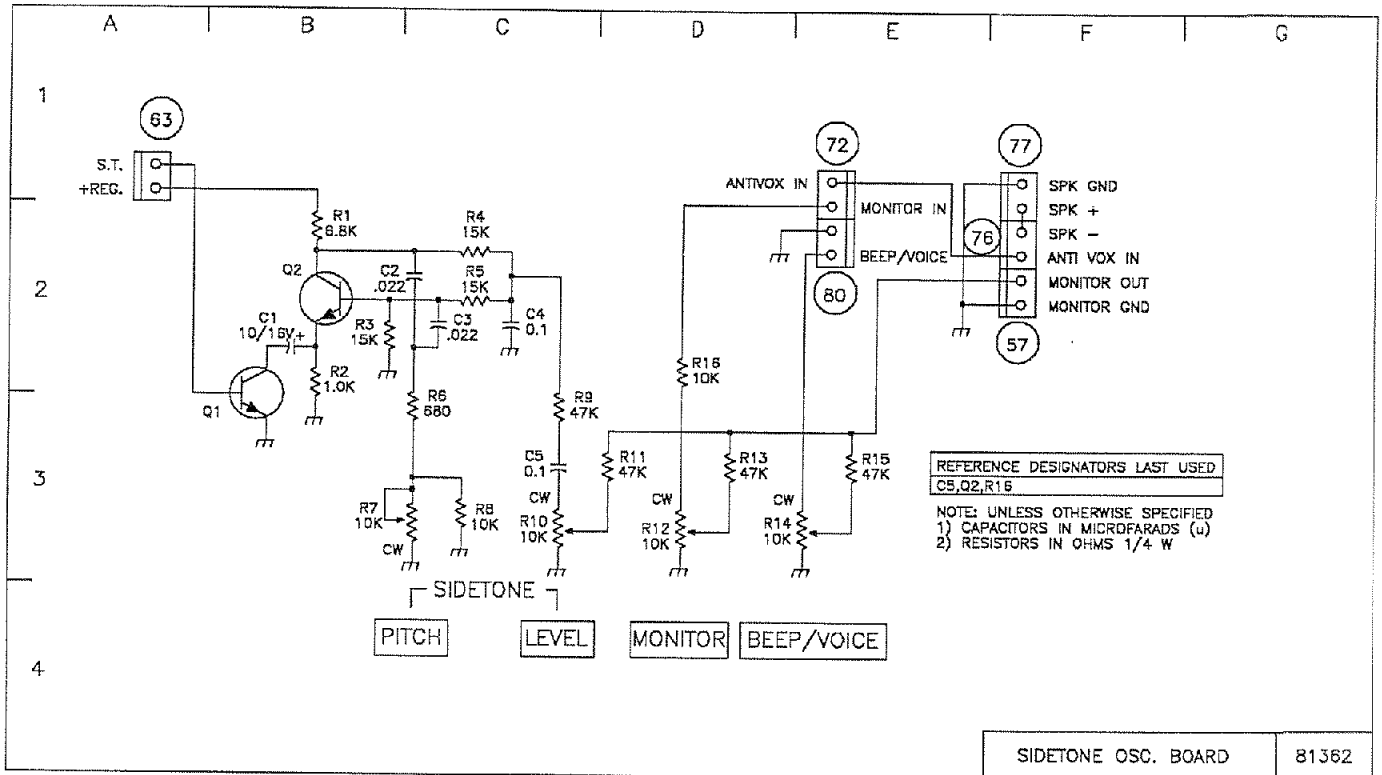

FIGURE 6-38. 81362 SIDETONE BOARD SCHEMATIC

6-15 TRANSMIT AUDIO/BFO BOARD (81457)

This board contains the transmit audio amplifiers, speech processor and VOX circuit, the 9 MHz BFO and balanced modulator. It is located at the left rear of the chassis, on top of the chassis deck behind the PLL shield box. Board mounted controls for VOX DELAY, VOX GAIN, and ANTI-VOX, and phono connectors for AUDIO IN and OUT and XVRT ENable and OUT are accessible through the rear panel.

Microphone audio from connector 73 or transmit audio from the rear panel AUDIO IN jack is amplified by U2B. The output of U2B splits four ways to drive the anode of diode switch D18, FM audio output connector 75, the speech PROCESSOR control pot at connector 74, and the VOX GAIN control R64. Diode D18 is normally forward biased through connector 70 when the PROCessor switch on the lower pot board is in the off position, connecting the amplified audio signal to the MIC gain control at connector 71.

The speech processor input at connector 74 is amplified to a nominal 1.2 Volts peak by U3A and again by U3B to approximately 1.8 Volts peak. One output of U3B drives rectifier D15 and compressor transistor Q13. Q13 clamps part of the original input to ground, effectively maintaining a constant audio level at the output of U3A. Another output of U3B drives the processor level meter through emitter follower Q12 and connector 78.

Half the output of U3A appears across clipper diodes D16 and D17, but no clipping occurs at the normal level of 0.6 volts. The clipper diodes limit fast audio transients, for which the compressor circuit is less effective, to 0.65-0.7 Volts. The compressed and limited speech processor output level is set by R81, and U4A buffers the output to the anode of diode switch D19. When the PROCessor switch is in the ON position, D18 is reverse biased, D19 is forward biased, and processed

audio is passed to the MIC gain control via connector 71. R18 is adjusted so that the peak levels of the processed and the unprocessed audio signals at connector 71 remain equal as the PROCessor switch is toggled between OFF and ON.

The output of the MIC gain control at the center pin of connector 70 is buffered by U4B and output to the balanced modulator U5 and to the MONITOR level control on the sidetone board via connector 72. The balanced modulator mixes the transmit audio signal from U4B with the BFO carrier to produce a 9MHz double sideband suppressed carrier output. U4B is enabled on pin 7 by "TD" voltage from the control board connector 60. The balanced modulator gain is increased in SSB mode by grounding bypass capacitor C24 through Q9. Q10 unbalances the modulator in CW and FSK modes. Tuned transformer T1 performs the match to the 50 Ohm DSB input of the 2nd mixer board at connector 37. R38 and R39 trim the AC and DC balance of U5 for maximum carrier null.

The VOX circuit is formed by U1, U2A, and Q11. Transmit audio from U2B is divided by VOX GAIN control R64 and amplified by U1B to drive positive voltage doubler D9-D10. Likewise anti-VOX input (speaker audio) on connector 72 is divided by ANTI VOX control R66 and amplified by U2A to drive negative voltage doubler D11-D12. The voltage doubler outputs are summed into comparator U1A by resistors R73 and R74. Whenever the sum at U1A pin 3 is more positive than the reference voltage at U1A pin 2, the comparator output goes high, charging C57 and saturating VOX keying transistor Q11. When the PTT/VOX switch on the switch board is in the VOX position, Q11 keys the transmitter via switch board connector 68 and control board connector 65. VOX DELAY control R79 sets the hold-in time of the VOX circuit by determining the discharge rate of C57.

The BFO oscillator/amplifier is formed by transistors Q6-Q8, and its frequency of operation is determined by crystals Y1-Y2, diode switches D20-D24, and capacitors C3-C10. Based on the mode of operation, transistor switches Q1-Q5 drive the diodes which select trimmer capacitors to set the BFO frequency at the proper place with respect to the IF filter response. Mode information from the control board enters at connector 60. The trimmers can be set with a high resolution counter at connector 46 by switching modes in the order listed below and adjusting the corresponding trimmer for the frequency indicated:

LSB receive, adjust C4 for 9.000000 MHz.

USB receive, adjust C6 for 9.003000 MHz.

FSK SPACE, adjust C7 for 9.002290 MHz.

FSK MARK, adjust C10 for 9.002100 MHz.

CW transmit or TUNE, adjust C9 for 9.000600 MHz.

NOTE: FSK MARK input voltage can be in the range of 0 to -15 Vdc. FSK SPACE input voltage should be in the range of +2.5 to +15 Vdc for proper operation.

Because of a slight interaction between the trimmers, these adjustments should be repeated at least once.

The BFO output from Q7 splits three ways. One output drives ALC transistor Q8 which controls the bias of oscillator transistor Q6 to maintain a constant output level. Another output serves as the carrier input to the balanced modulator U5. The third BFO output drives the product detector on the IF/AF board through connector 46.

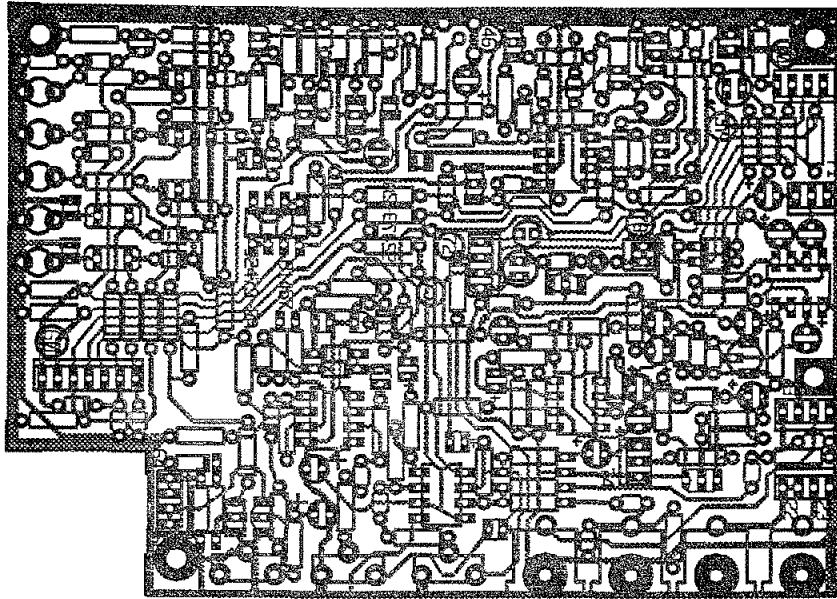

FIGURE 6-39. 81457 TRANSMIT AUDIO/BFO BOARD CIRCUIT TRACE

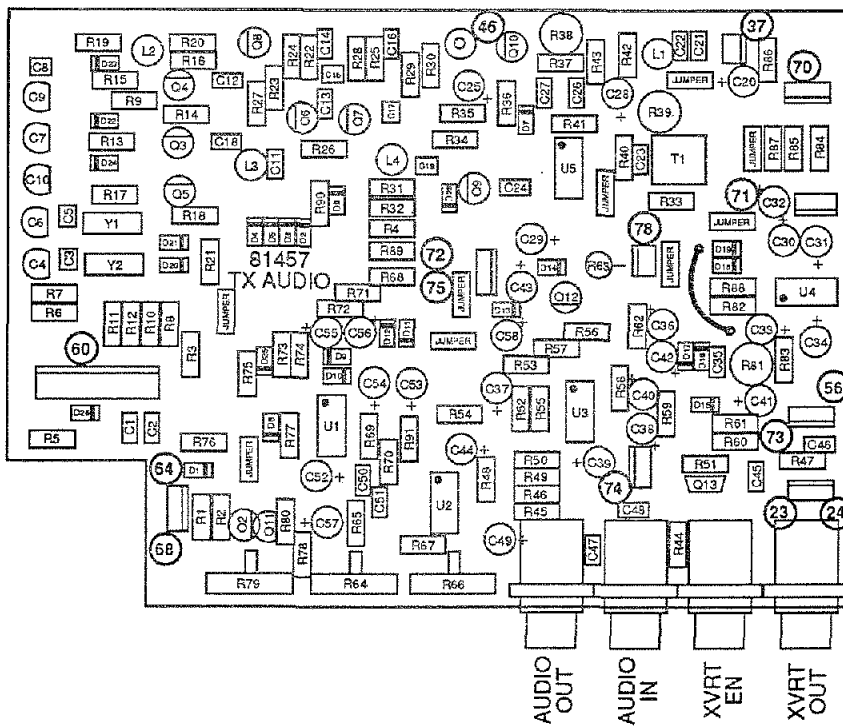
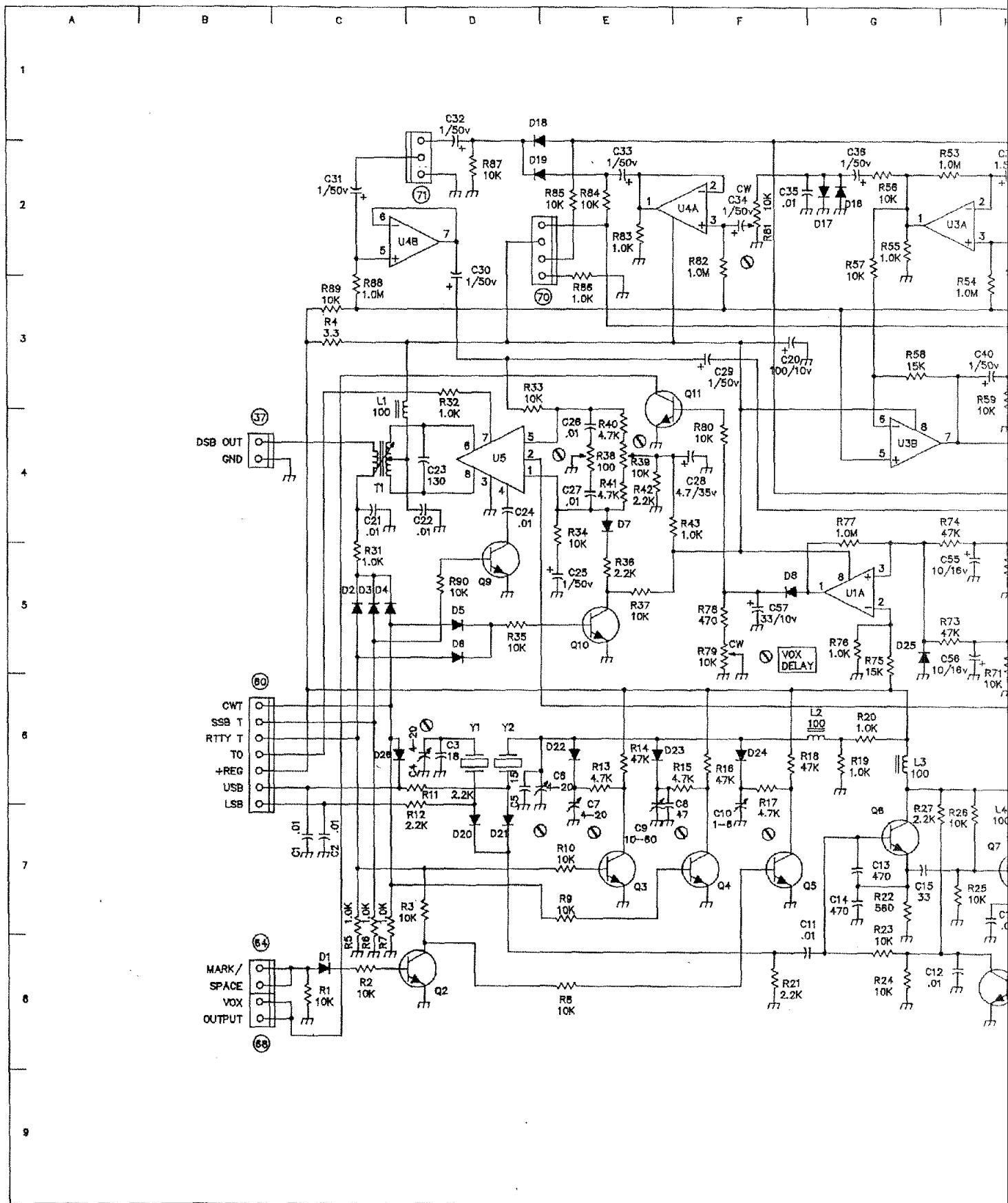
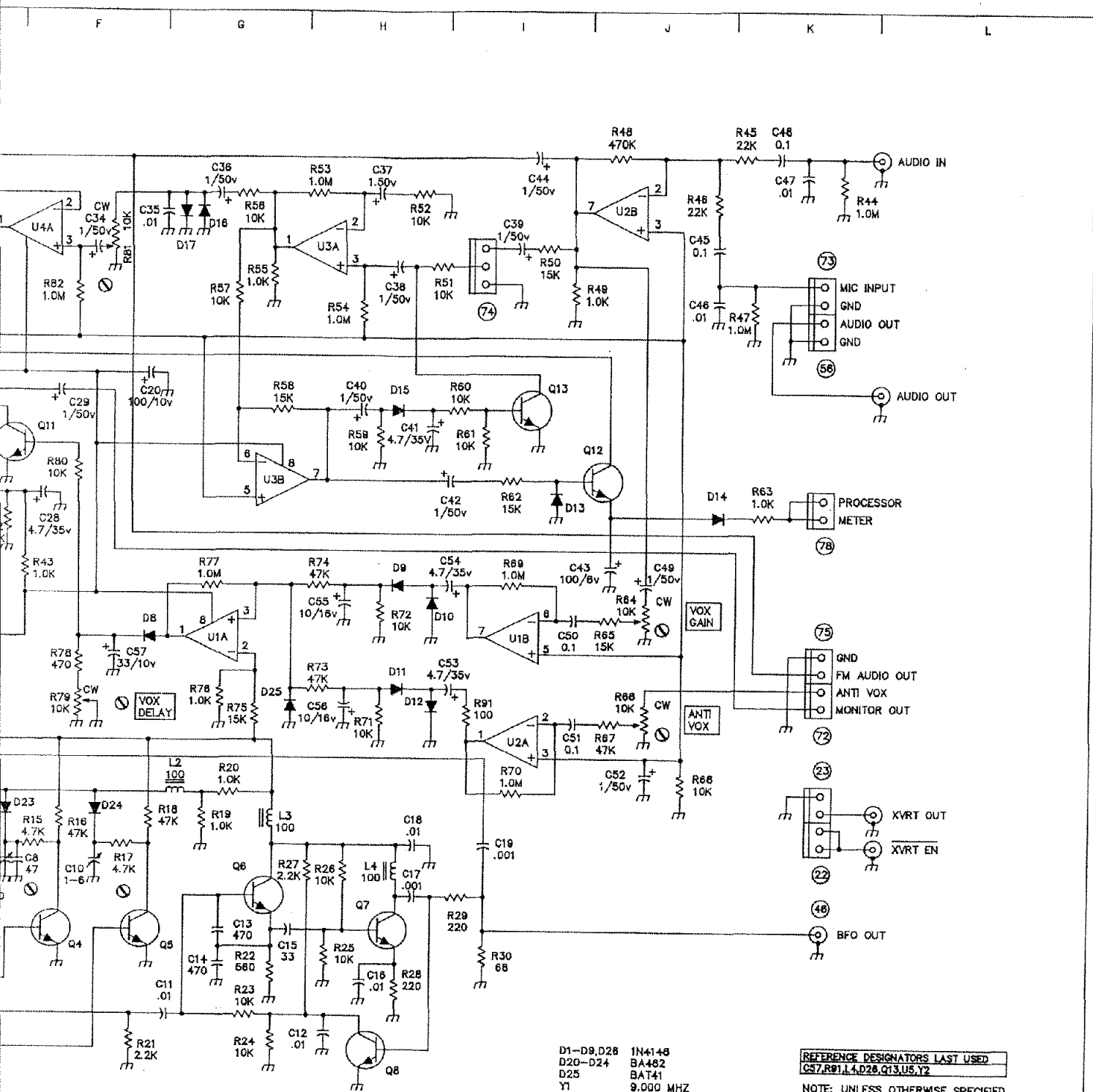

FIGURE 6-40. 81457 TRANSMIT AUDIO/BFO BOARD COMPONENT LAYOUT





D1-D8, D28	1N4148
D20-D24	BA482
D25	BAT41
Y1	9.000 MHZ
Y2	9.003 MHZ
U1-U4	LM358N
U5	CA3053E
Q2-Q5	MPS6514
Q6	MPS5179
Q7-Q12	MPS6514
Q13	MPSU01

REFERENCE DESIGNATORS LAST USED
 C57, R91, L4, D26, Q13, U5, Y2

NOTE: UNLESS OTHERWISE SPECIFIED
 1) CAPACITORS IN PICOFARADS (PF)
 2) INDUCTORS IN MICROHENRYS (UH)
 3) RESISTORS IN OHMS $\pm 5\%$ 1/4W

6-59/6-60 blank

FIGURE 6-41 TX AUDIO / BFO 81457

6-16 LOW LEVEL AMPLIFIER/NOISE BLANKER (81340)

This board contains the low level wide band amplifier for the transmitter, the receiver noise blanker, "T" and "R" voltage generator, and the "+REG" and meter lamp regulators. It is located on the left upper chassis on top of the PLL shield.

The operating frequency transmit signal from the Xtal Osc-LO Mixer board enters on connector 24, is amplified by class A amplifier transistors Q9 and Q10, and exits to the final power amplifier at connector 79. During transmit, "T" voltage supplies bias to both stages through R14 and R20.

"T" and "R" voltages are developed by Q1-Q8 based on the level of the "TD" pin from control board connector 62. In transmit "TD" is high and Q4 sources approximately 12.5 Volts to the "T" line through R8, while Q8 holds the "R" line low. In receive "TD" is low and Q7 sources approximately 8.5 Volts to the "R" line through R13, while Q5 holds the "T" line low.

At connector 31, a sample of the 9 MHz receive IF signal from the 9 MHz Crystal Filter board is input to noise blanker amplifiers U3 and U4. Part of the output of U3 is sent to the FM option connector. The output of U4 drives detector diodes D2 and D3 to produce a noise envelope signal across C30. U5A buffers this signal and charges AGC capacitor C20 through R39 and discharges it through R38 to determine the critical noise blanker AGC time constants. U5B amplifies the noise envelope to drive the base of noise threshold transistor Q12. The emitter of Q12 is biased with a variable voltage from the noise blanker LEVEL control at connector R. Noise pulses which overcome this bias voltage are amplified by Q12 and sent to the pulse amplifier stages Q13-Q17. The leading edge of a noise pulse is applied directly to the NB Pulse pin of connector 32 via R55 and D5. The trailing

edge is delayed by integrator Q15 and applied in parallel with the leading edge signal to form a complete blanking pulse. Connector 32 carries the blanking pulse to the noise gate on the 9 MHz Crystal Filter board. Power for the pulse amplifier stages is through connector 67 and the N.B. switch on the front panel switch board.

A regulator composed of U1 and Q11 supplies 8.5 Volts "+REG" voltage to all boards via connector 62 and the control board. Q11 is mounted on the PLL shield plate and connected with cable Q. Meter lamp regulator U2 is likewise mounted to the PLL shield and connected with cable P. Regulated 6 Volts is supplied to the meter lamps through connector O.

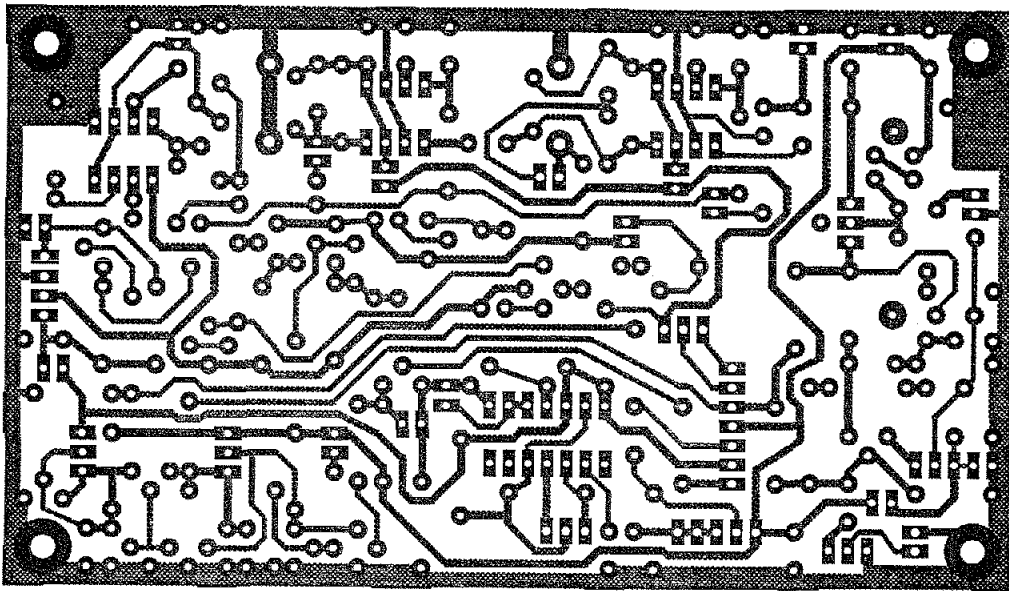

FIGURE 6-42. 81340 L. L. AMPLIFIER / NOISE BLANKER CIRCUIT TRACE

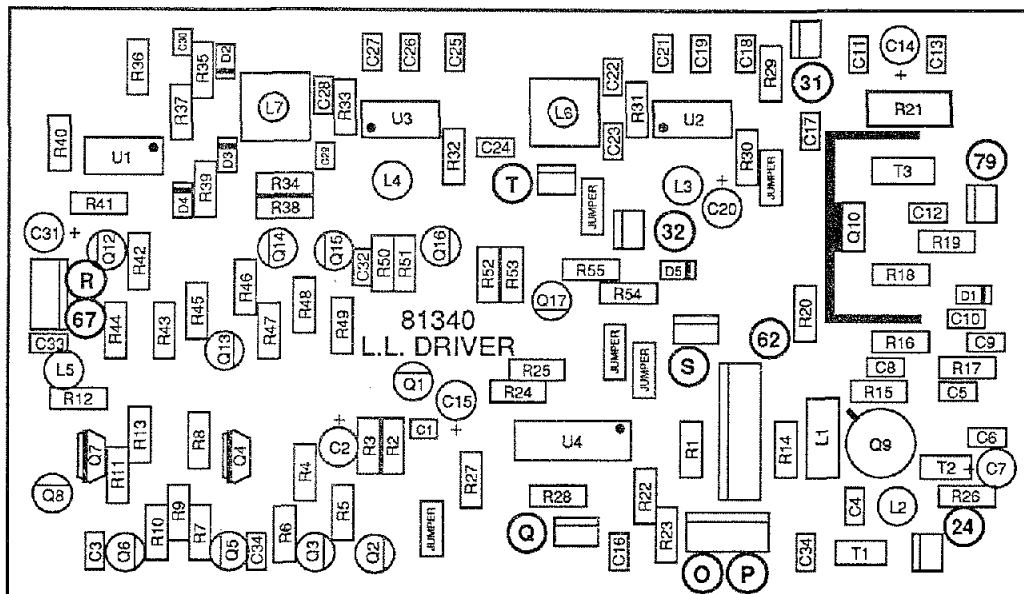
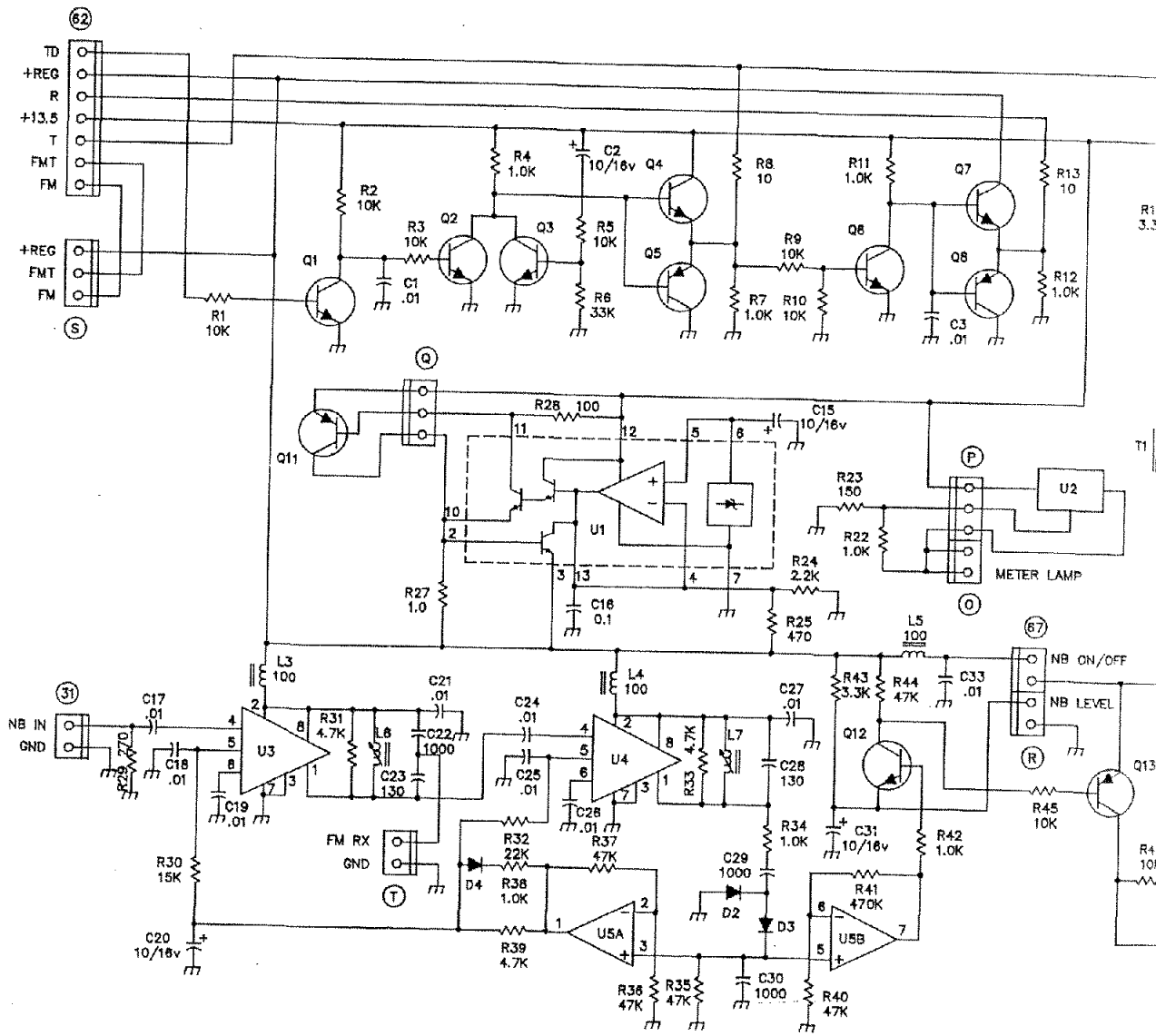

FIGURE 6-43. 81340 L. L. AMP. / NOISE BLANKER COMPONENT LAYOUT



REFERENCE DESIGNATORS LAST USED
 R33, C33, L7, U5, D5, Q17, T3

NOTE: UNLESS OTHERWISE SPECIFIED
 1) CAPACITORS IN PICOFARADS (PF)
 2) INDUCTORS IN MICROHENRYS (UH)
 3) RESISTORS IN OHMS ±5% 1/4W

U1	MC1723P	Q6, Q12
U2	MC7805CT	Q14-Q16
U3-U4	MC1350	Q4-Q7
U5	LM358N	Q5, Q8
D1	1N4002	Q13, Q17
D2-D4	BAT41	Q9
Q5	1N4148	Q10
Q1-Q3	MPS6514	Q11

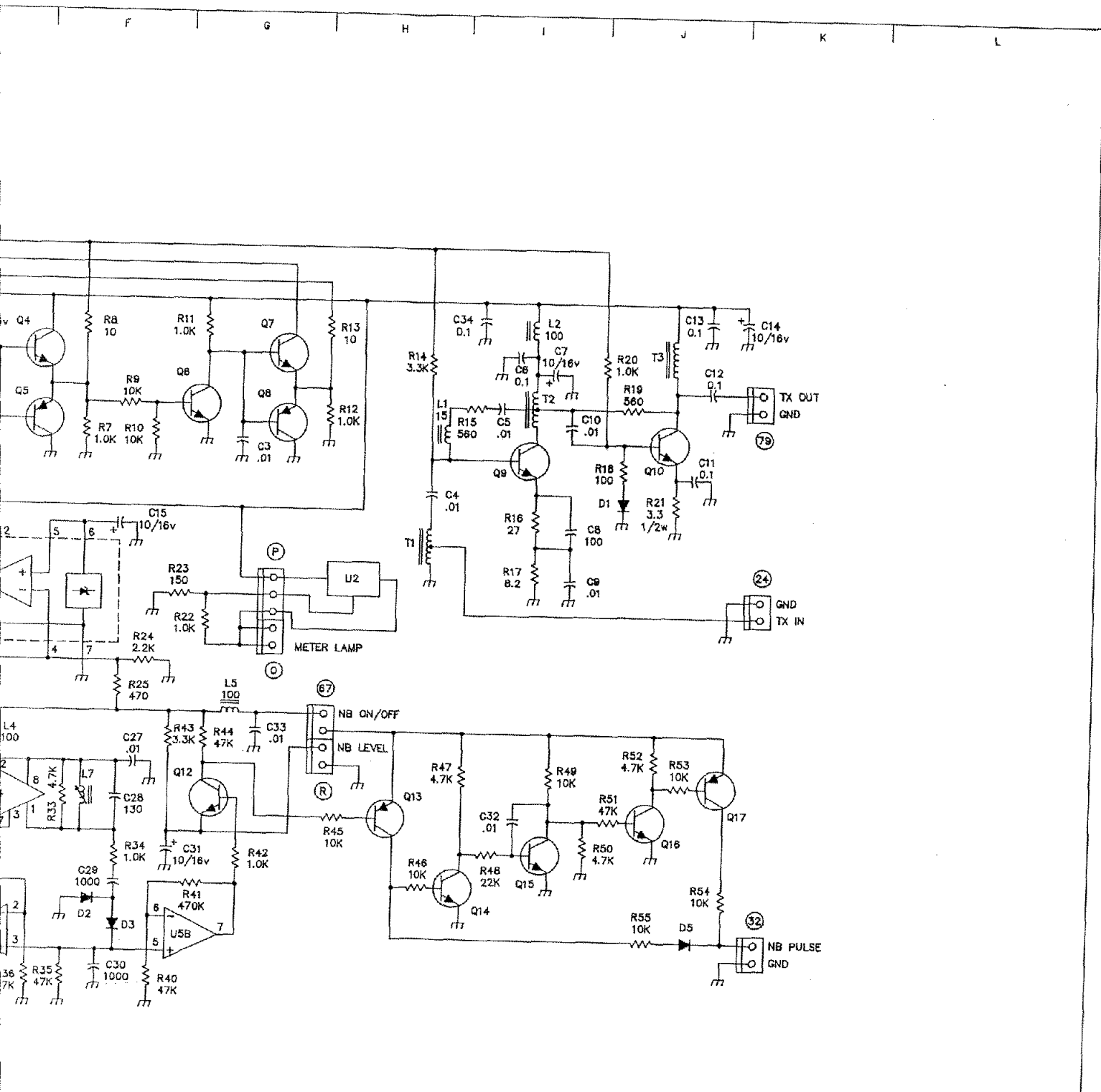

LAST USED
 SE SPECIFIED
 FARADS (PF)
 HENRYS (uH)
 ±5% 1/4W

U1	MC1723P	Q8, Q12	MPS6514
U2	MC7805CT	Q14-Q16	MPS6514
U3-U4	MC1350	Q4-Q7	MPSU01
U5	LM358N	Q5, Q6	2N5087
D1	1N4002	Q13, Q17	2N5087
D2-D4	BAT41	Q9	2N3866
D5	1N4148	Q10	MRF476
Q1-Q3	MPS6514	Q11	MJE370

6-63/6-84 blank

FIGURE 6-44 LOW LEVEL AMP 81340

6-17 RF POWER AMPLIFIER (81342) and PA BIAS BOARD (81343)

The high power RF amplifier, its push-pull driver stage, and the PA bias board are housed in a metal box which is an integral part of the heatsink assembly. The unit is attached to the rear panel with four hex head screws. Input is received through connector 79 on the low level amplifier board, and the 100 Watt output is through a miniature coaxial cable soldered to pins on the lowpass filter board. "T" voltage enters the unit on the small blue wire from connector 11 on the lowpass filter board, and 13.5 Volts dc enters on the large red wire from the dc power board.

Q1 and Q2 form a wideband class AB linear driver stage with input and output impedance matching accomplished by broadband transformers T1 and T3. RC networks R1-C1 and R6-C2, in conjunction with feedback networks R3-L3-C5, R8-L4-C6, and emitter networks R4-R5-C3 and R9-R10-C4, control the input impedance and flatten the gain variation of the transistors over the frequency range of 1.6-30 MHz. Regulated bias is fed to this stage by the green wire from connector M on the PA bias board.

Q3 and Q4 form the high power broadband output stage of the transmitter. This stage is also biased to linear class AB operation by a regulator on the PA bias board. Input impedance and gain variation with frequency are controlled by RC input networks and RF feedback similar to the driver stage. Broadband transformer T4 matches the output stage to 50 Ohms for driving the transmit lowpass filters. Regulated bias for the output stage arrives on the brown wire from connector M on the PA bias board.

Bias for both stages is temperature compensated to maintain a relatively constant operating point by mounting the bias reference diodes D2 and D3 in thermal contact to the heatsink. The temperature dependant voltage

across each reference diode is added to a portion of the "T" voltage and the sum is used as a reference voltage for the respective bias regulator U1B-Q1 or U1A-Q2 on the PA bias board. In receive, "T" voltage is low and both regulators are cut off, removing bias from both PA stages. When "T" goes high, capacitor C27 delays the rise of the bias reference voltages, reducing the gain of the PA until the rest of the transceiver settles into a stable transmit mode.

The bias adjustment pots R11 and R21 are accessible through the bottom shield of the transceiver. To adjust PA bias, an dc amp meter must be inserted in series with the large red 13.5 Vdc lead to the dc power board. Unplug connector 79 from the low level amplifier board to remove drive from the PA. Key the transmitter in USB mode. While watching the meter, rotate first the final bias pot R21 and then the driver bias pot R11 to produce minimum current. Now rotate the driver bias pot R11 to increase the meter reading by 50 milliamps. Next rotate the final bias pot R21 to produce an additional increase of 500 milliamps on the meter. Remove the meter and reconnect the red wire to the dc power board and connector 79 to the low level amplifier board.

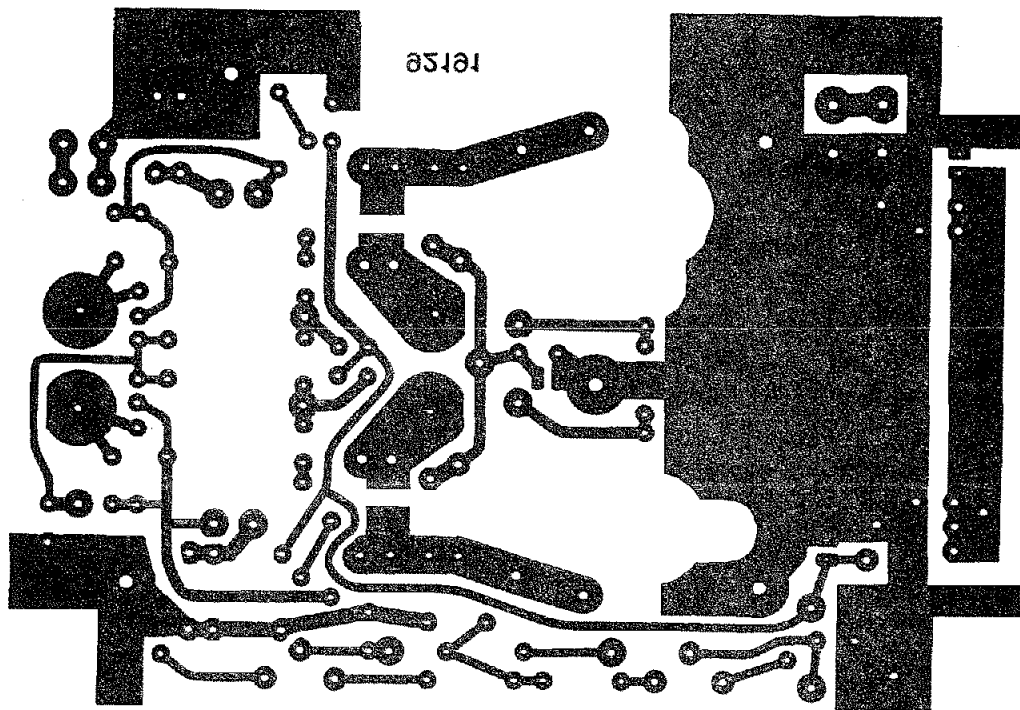

FIGURE 6 - 45. 81342 RF POWER AMPLIFIER CIRCUIT TRACE

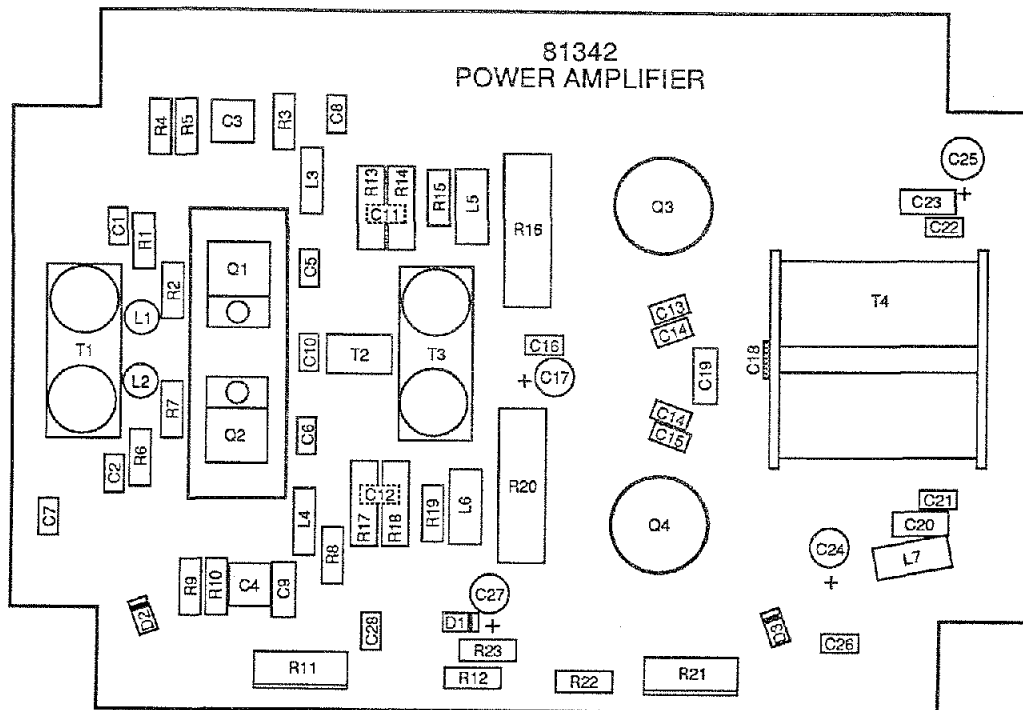

FIGURE 6 - 46. 81342 RF POWER AMPLIFIER COMPONENT LAYOUT

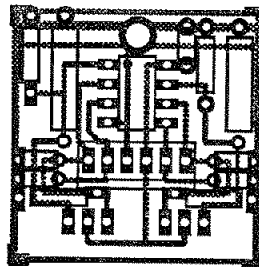

FIGURE 6 - 47. 81343 PA BIAS BOARD CIRCUIT TRACE

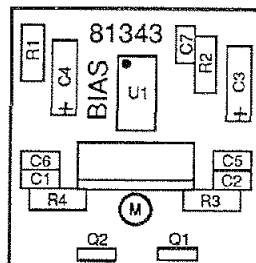

FIGURE 6 - 48. 81343 PA BIAS BOARD COMPONENT LAYOUT

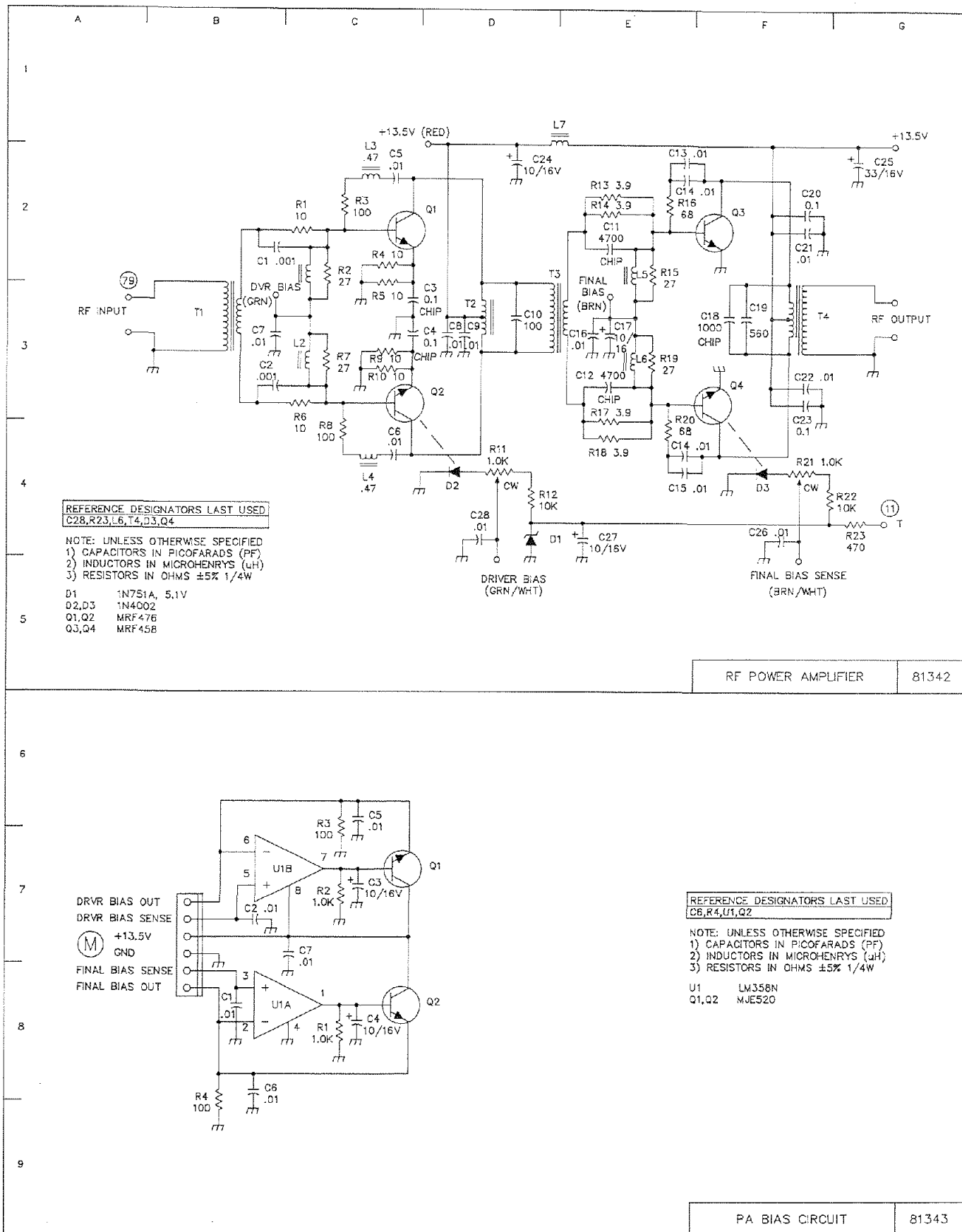

FIGURE 6-49. 81342 RF POWER AMP. and 81343 PA BIAS BOARD SCHEMATIC

6-18 LOGIC BOARD (81442)

This board contains the main system microprocessor, two I/O driver integrated circuits, a non-volatile RAM chip, a real time clock chip, an edge card connector for the optional voice readout board, and the rotary encoder circuitry.

The main microprocessor, U7, is the heart of the system. This is an 8-bit CMOS microprocessor with 29 I/O lines, an 8 K ROM, 176 bytes of CMOS RAM, two serial communication lines and a built in 16 bit timer. This microprocessor contains an internal oscillator whose frequency is controlled by Y1. The I/O lines going to connector 84 are used to control the PLL synthesizer circuits. On connector 66, U7 monitors the TX RQ line to tell when it should go into the transmit mode. When TX RQ goes high, U7 will compute the correct transmit frequency and insert any needed timing delays before enabling the transmitter output by setting TX ACK high. Connector J provides access to the RESET line of U7. This is connected to a push button switch located on the right side of the OMNI V and is used to force a RESET of U7 in the event that the system malfunctions and cannot be cleared by simply turning the POWER switch off and back on. Pin 13 (PB1) of U7 is used to monitor the power supply line (+13.5V) in order to detect when the POWER switch has been turned off. When this happens, U7 is placed into a "sleep" mode to conserve power but still retain its memory. When power is turned on, with U7 in the "sleep" mode, transistors Q1 and Q2 generate a negative going pulse on the INT line of U7. This wakes the microprocessor up and restores it to normal operation. The INT line is also used by the encoder circuit to tell the microprocessor to change frequency. The clock pulse from the encoder circuit is coupled by C17 to the IRQ pin. Pin 12 (PB0) of U7 is used to tell whether the encoder is tuning up(high) or down(low).

The I/O lines going to connector 91 are used as input lines from the key matrix of the key pad. The lines going to connector 98 are used to interface with the control chip on the VF Display Driver board. Power for the VF Display Driver is supplied via connector D. Pins 22-24 (PC6-PC4) of U7 is used to control the optional Model 257 Voice Readout. The outputs at connector A go to U6 and are used to select a column during the key pad scanning routine.

U6 is a 1 of 10 decoder which is used to scan the columns of the key pad matrix. It is controlled by the signals coming from U7 via a jumper cable at connector A. The outputs of U6 go to connectors 94 and 97, which in turn go to the key pad. Whenever a particular column is selected during the scan, that output goes low, while all others remain high.

Pins 4-6 (PA7-PA5) of U7 are used to send serial data to U1, a 32 bit latched driver. The outputs of U1 at connector 82 are used to select the correct low pass filter circuits, depending on the operating frequency of the OMNI V. Output lines going to connector 59 are used to select the desired operating mode on the Control Board. Outputs from connector 92 drive the corresponding LEDs on the Keypad. Outputs from connectors 41 and 34 are used to select the desired crystal filter position while the corresponding LEDs are driven by the lines going to connectors 95 and 96. Outputs from connector 96 are used to drive additional LEDs on the Keypad. The outputs at connector 99 are used to drive the LEDs on the VF Display Board.

The main tuning control consists of an optical rotary encoder located on the Keypad Board. This encoder generates quadrature signals (each signal being 90° out of phase). The rotary encoder produces 120 pulses per revolution of the Main Tuning Knob. The two quadrature signals are sent via connector 93 to U2 and U3. These gates detect the leading and trailing edges of the signals and generate an

output pulse for each edge, thus multiplying the number of pulses by four. An optional remote encoder may also be connected via connector E to provide remote tuning operation. Both the main and remote encoder signals are applied to U3, a quad analog switch circuit, which selects and routes the active encoder signals to U4 and U2. The pulses applied to U2 are used to detect the direction of the encoder. The UP/DOWN output of U2 (pin 1) goes to PB0 of U7. The pulses are also summed through U4A and U4C. The clock pulses thus generated (480 per revolution of the encoder) are applied via C17 to the IRQ line of U7. They are also sent to U5 which buffers the signal and then integrates it to develop a tuning rate detector. When the number of pulses exceeds a predetermined threshold, the output of U5D goes high. This signal is connected to pin 36 (PD7) of U7. When U7 sees the SHIFT line go high, it changes the tuning step size of the synthesizer to a larger value.

The real time clock circuit consists of U10, Y2, and trimmer capacitor C13. Backup power is supplied via connector C from a replaceable 3 volt lithium battery B1.

To calibrate the clock a frequency counter may be connected to TP1 and trimmer C13 adjusted until the counter reads 128 Hz. If the counter has period measurement capability, an even more accurate setting may be obtained by placing the counter in period mode and adjusting C13 for a period of 7.8125 mS.

U10 is serially controlled by U7 pins 10-11 (PA1-PA0). These two serial control lines also connect to U8, a 256 byte NVRAM, which is used to store memory information.

The microprocessor U7 also contains two dedicated serial communication lines, pins 29 (RDI) and 30 (TDO). These lines go to U11 and to connector 41. U11 is used to convert the data lines from TTL to RS232 levels before being applied to connector B. Both TTL and

RS232 levels are available on connector B, which is routed to the rear panel mounted DB-25 connector. These lines allow the OMNI V to be controlled by a remote computer.

Connector 80 supplies the audio signal from U7 pin 21 (PC7) and the optional Voice Readout to the audio circuits of the OMNI V.

Connector 2 supplies +13.5 Volts primary power for U9, a +5.6 Volt regulator and for U1, the 32 bit serial driver.

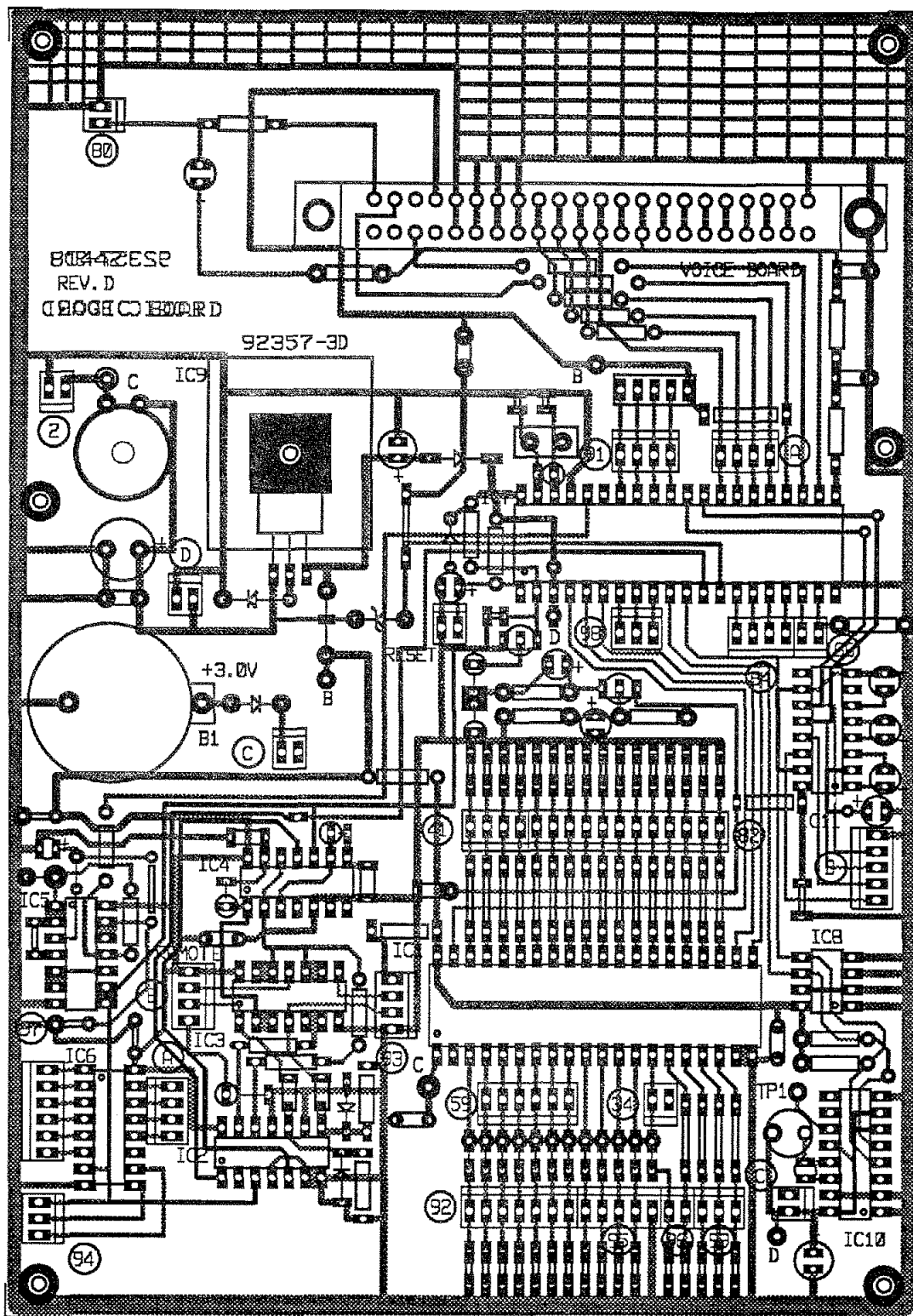

FIGURE 6-50. 81442 LOGIC BOARD CIRCUIT TRACE

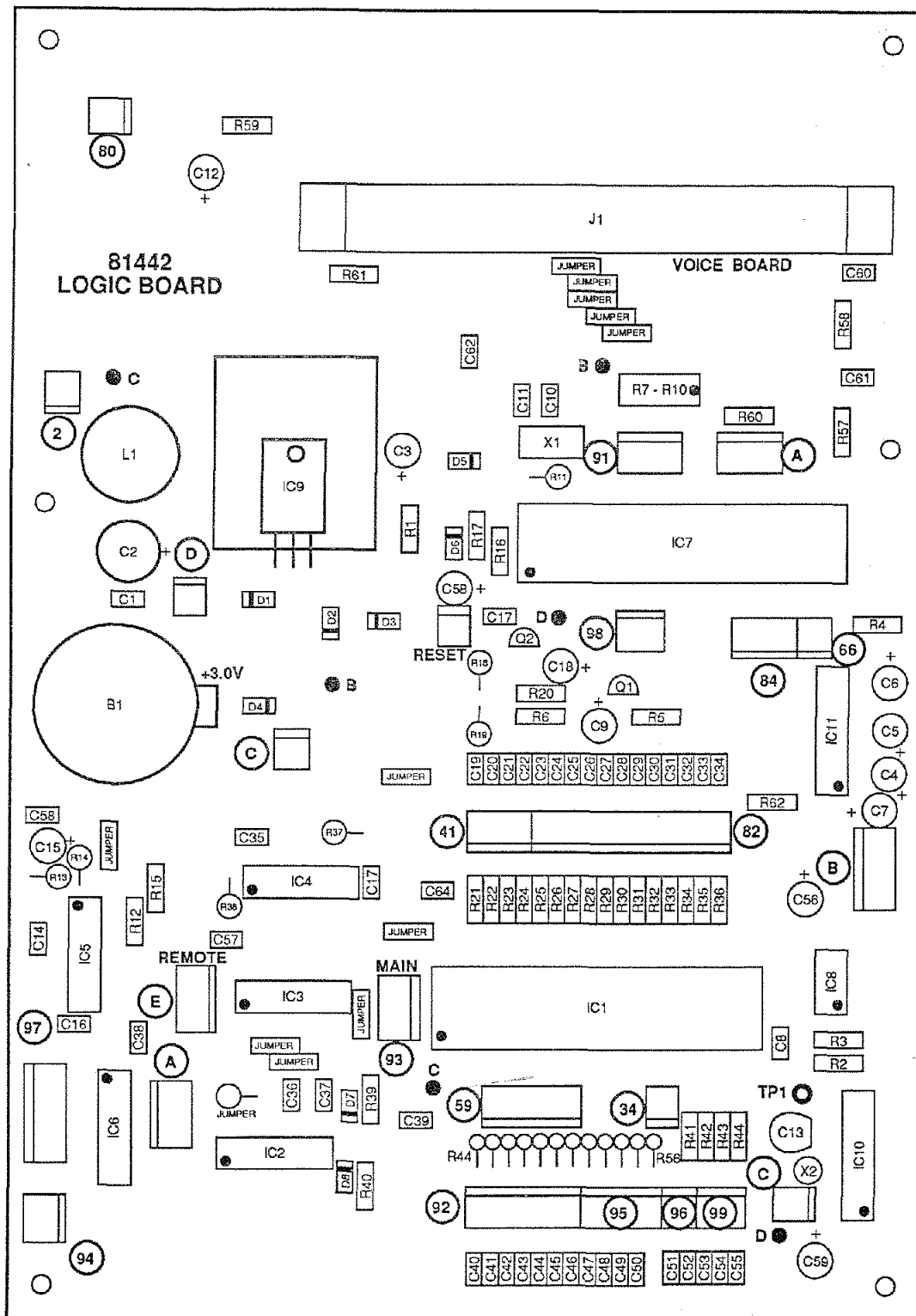
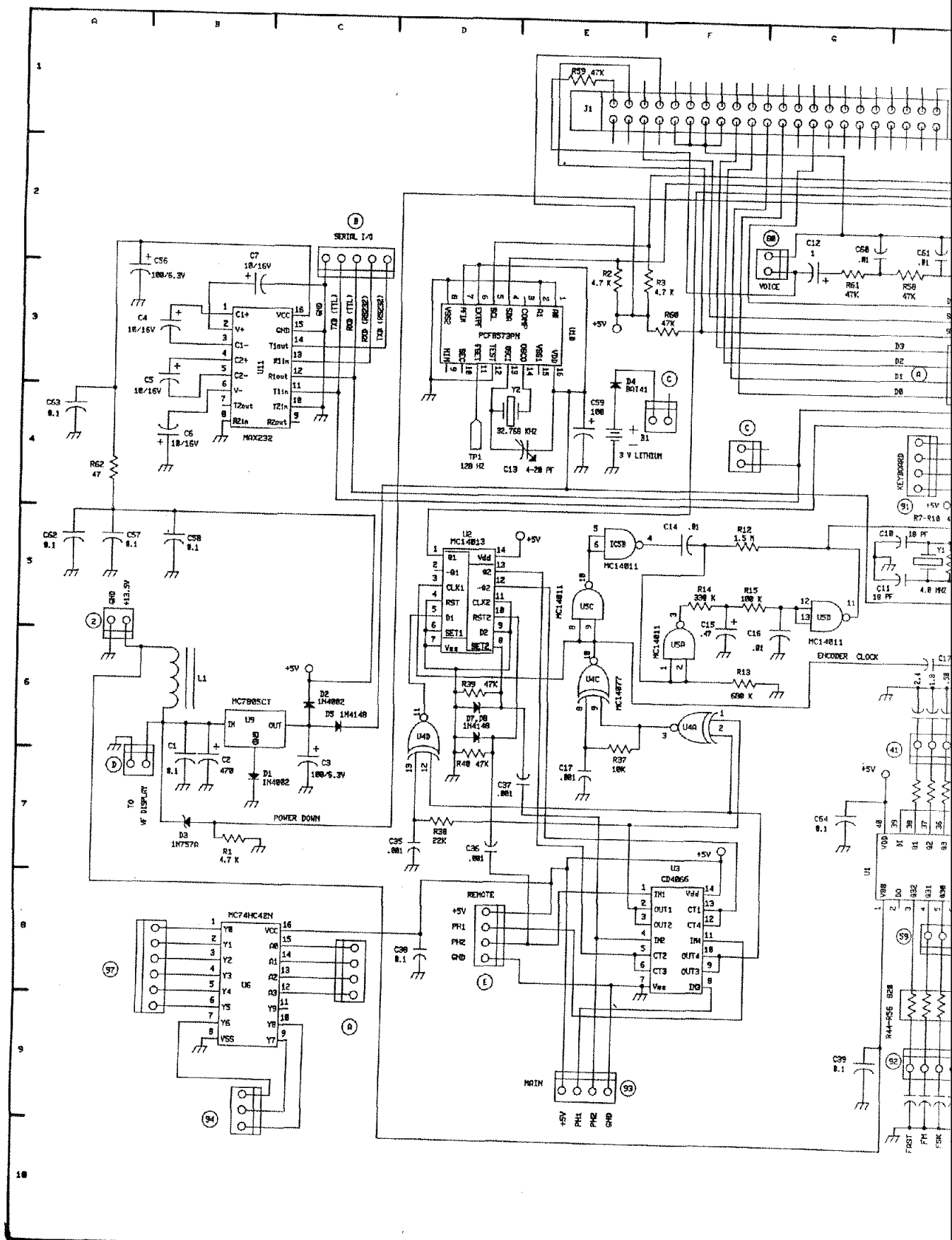
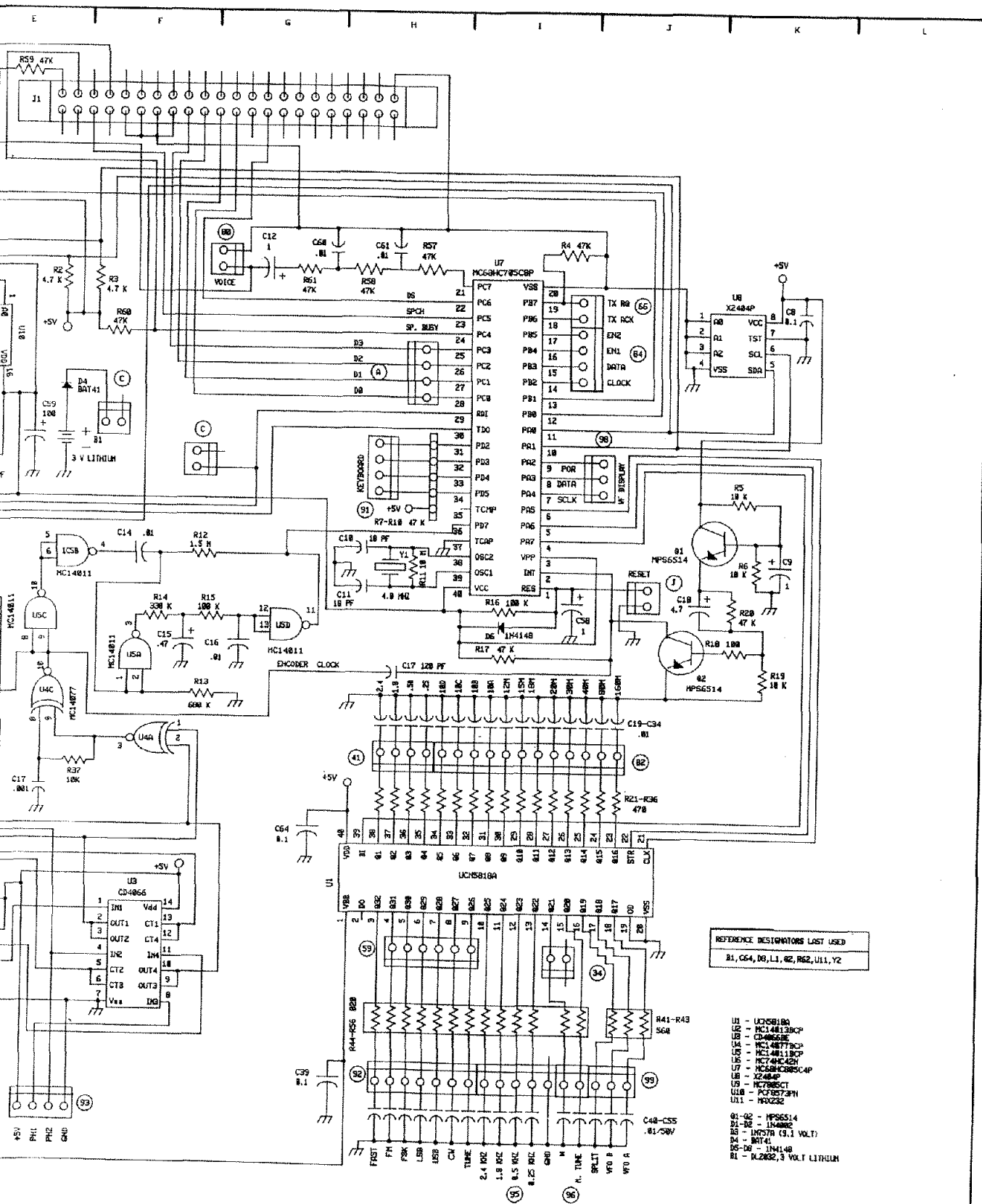

FIGURE 6-51. 81442 LOGIC BOARD COMPONENT LAYOUT





REFERENCE DESIGNATORS LAST USED
 R1, C64, D8, L1, R2, R82, U11, Y2

- U1 - UCN5918A
- U2 - MC14813BCP
- U3 - CD4066
- U4 - MC14817BCP
- U5 - MC14811BCP
- U6 - MC74HC42H
- U7 - MC68HC785C8P
- U8 - X2484P
- U9 - M7805CT
- U10 - PC8273PH
- U11 - MAX232
- R1-R2 - MP65514
- R3-R4 - 1N4002
- R5 - 1N570 (3.1 VOLT)
- R6 - BR141
- R7-R8 - 1N4148
- R9 - M2302, 3 VOLT LITHIUM

6-75/6-76 blank

FIGURE 6-52 LOGIC BOARD 81442

6-19 KEYPAD BOARD (81446)

The keypad board contains an array of 35 key switches, 13 LED indicators and a rotary shaft encoder. The circuit board is mounted to the rear of the front panel keypad bezel and is connected to the digital board through six connectors which are accessible through the sub panel at the rear of the fold down front panel assembly.

The keypad switches are arranged electrically in an array of nine columns and four rows. The columns are scanned through connectors 94 and 97, and the rows are sensed through connector 91. The microprocessor detects a key closure by strobing each column line low in sequence, while watching for a low to appear on any of the row lines. The location of the closure is defined by the intersection of the column and row lines that are simultaneously low.

The digital board drives the indicator LEDs through connectors 92, 95, and 96. The diodes are illuminated by positive voltage drive and all diode cathodes return to ground through connector 95.

Output pulses from the shaft encoder are sent to the digital board via connector 93. Connector 93 also supplies 5 Volt power to the encoder.

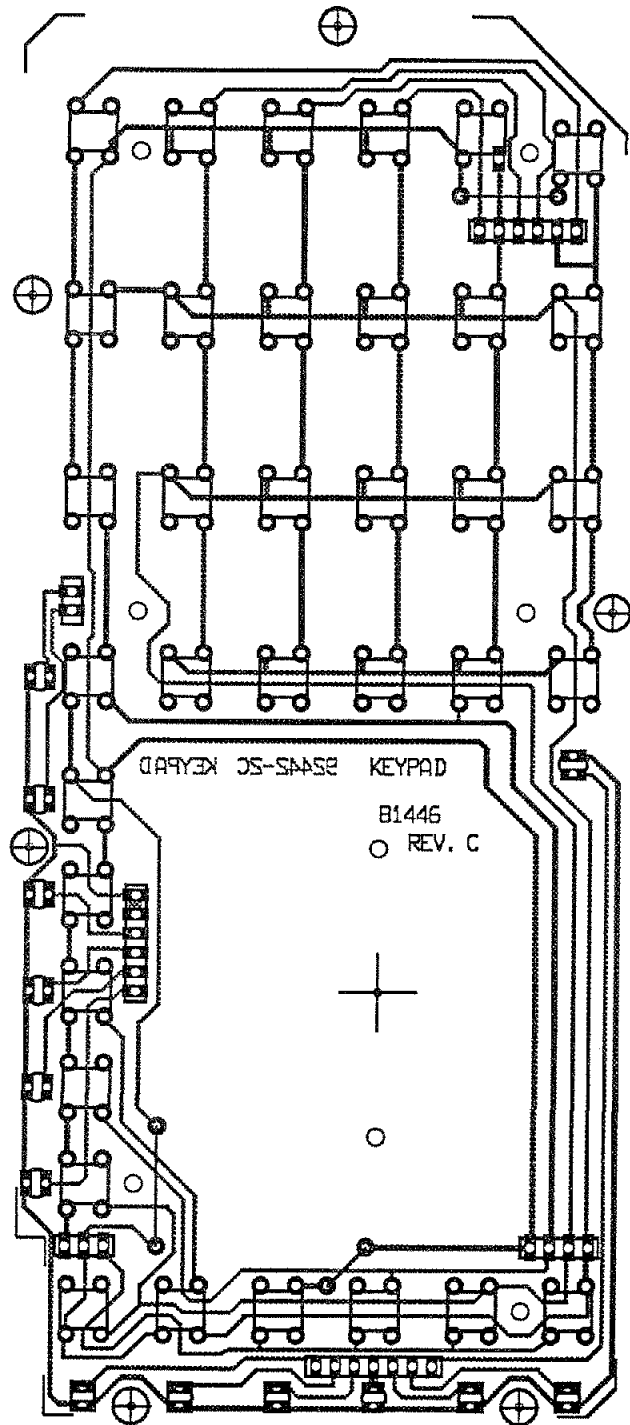

FIGURE 6-53. 81446 KEYPAD BOARD CIRCUIT TRACE

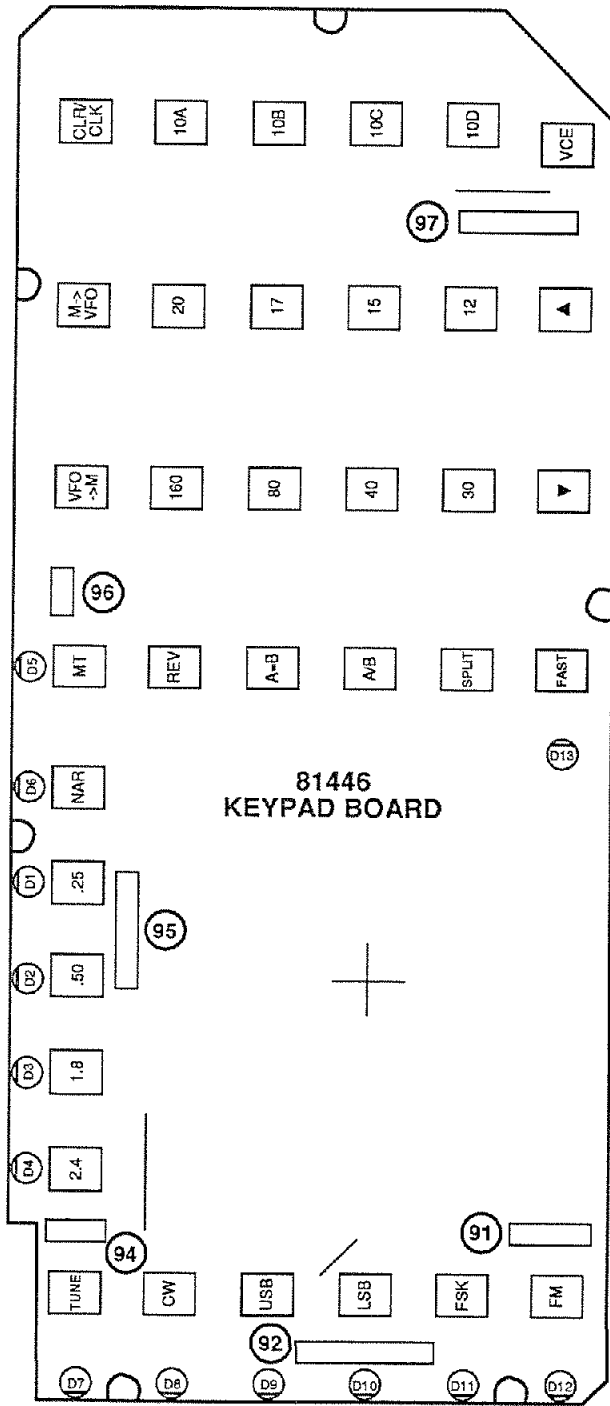

FIGURE 6-54. 81446 KEYPAD BOARD COMPONENT LAYOUT

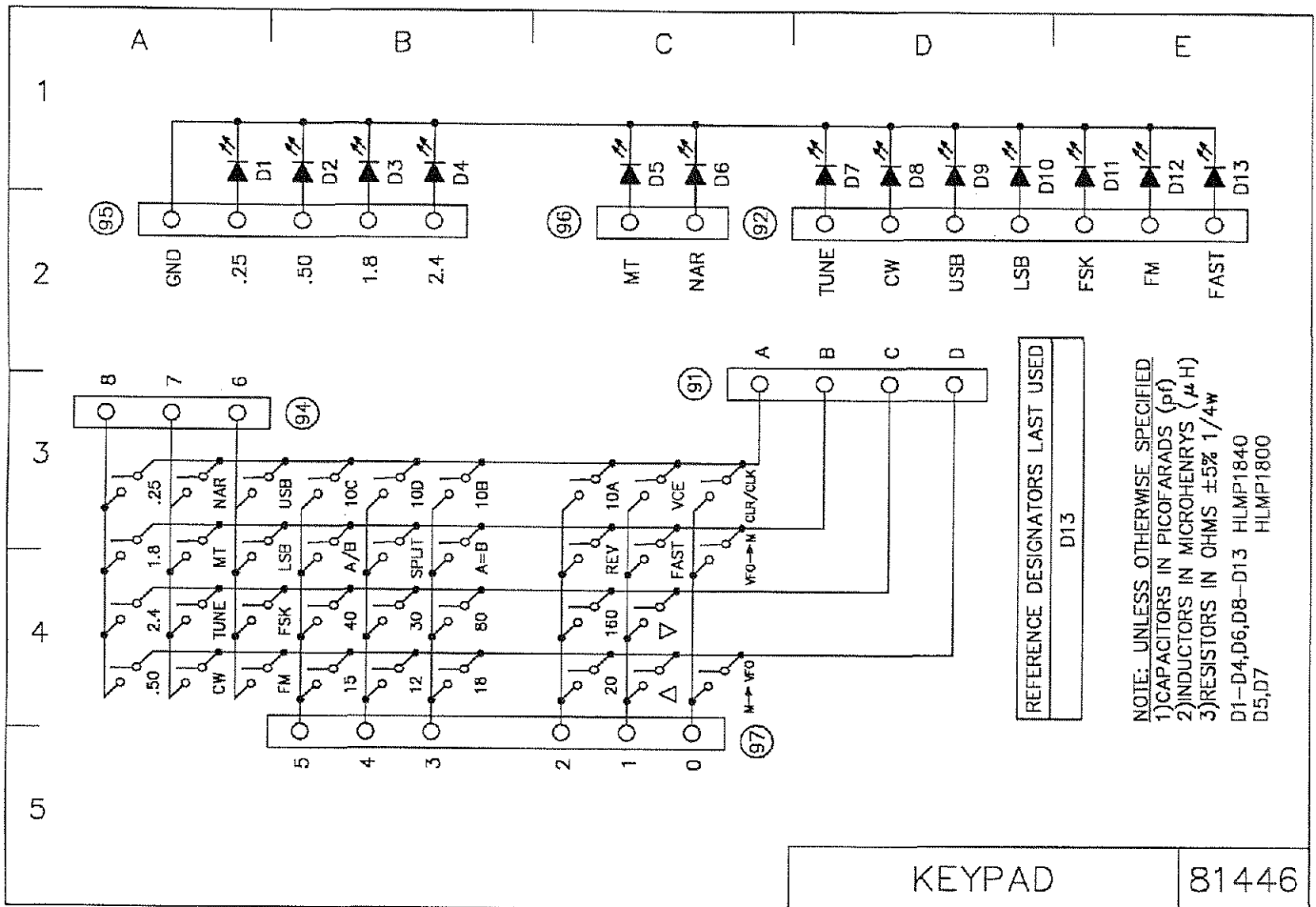

FIGURE 6-55. 81446 KEYPAD BOARD SCHEMATIC

6-20 VF DISPLAY DRIVER BOARD (81447)

This board contains an intelligent vacuum fluorescent display driver integrated circuit U1. Also on this board is a DC-to-DC converter used to generate the -30 VDC and 3 VAC required to drive the display.

U1 receives information serially from the main microprocessor, located on the Logic Board, via connector 98. Q3 is used to shift the level of the power-on-reset (POR) pulse coming from the main microprocessor. After U1 has been reset and setup by the microprocessor, it begins generating multiplexed segment and digit information at about a 1 kHz rate. These signals drive the VF display directly through connectors J1 and J2.

The DC-to-DC converter consists of free running oscillator Q1, Q2, T1, and a voltage doubler circuit consisting of diodes D3-D6 and capacitors C6-C9. In addition, D8 and D9, 16 volt zener diodes, help provide some degree of voltage regulation. The frequency of oscillation of U2 is controlled by C2, C3 and the combination of R4 and R5. The output of T1 is used to drive the filaments in the vacuum fluorescent display.

Power for the DC-to-DC convertor is supplied from the logic board via connector D. Resistor R1 and zener diode D1 provide a regulated +5 VDC to U1. Anode bias voltage for the display is set by D2. Diode D7 protects U1 from excessive voltage transients. Control of the three LED annunciators on the display board is provided via connector 99 from the logic board.

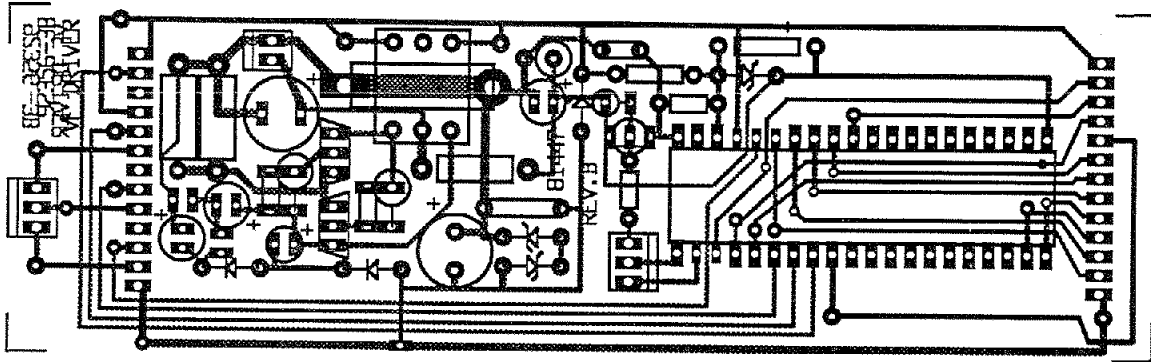

FIGURE 6-56. 81447 VF DISPLAY DRIVER BOARD CIRCUIT TRACE

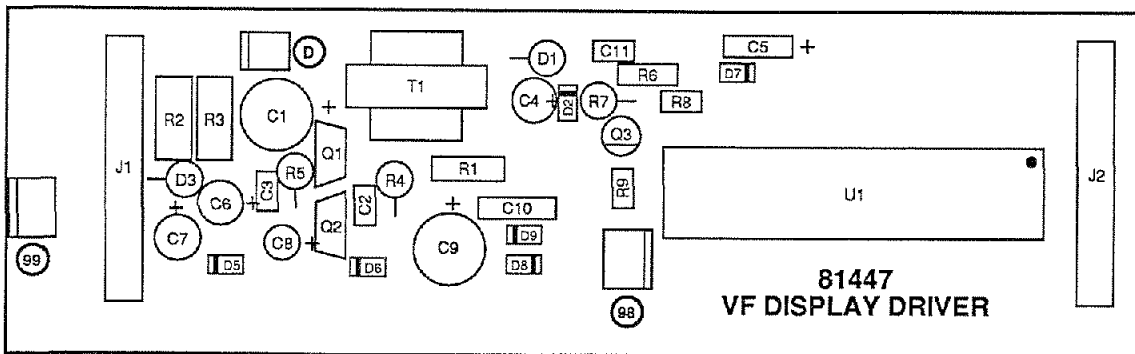

FIGURE 6-57. 81447 VF DISPLAY DRIVER BOARD COMPONENT LAYOUT

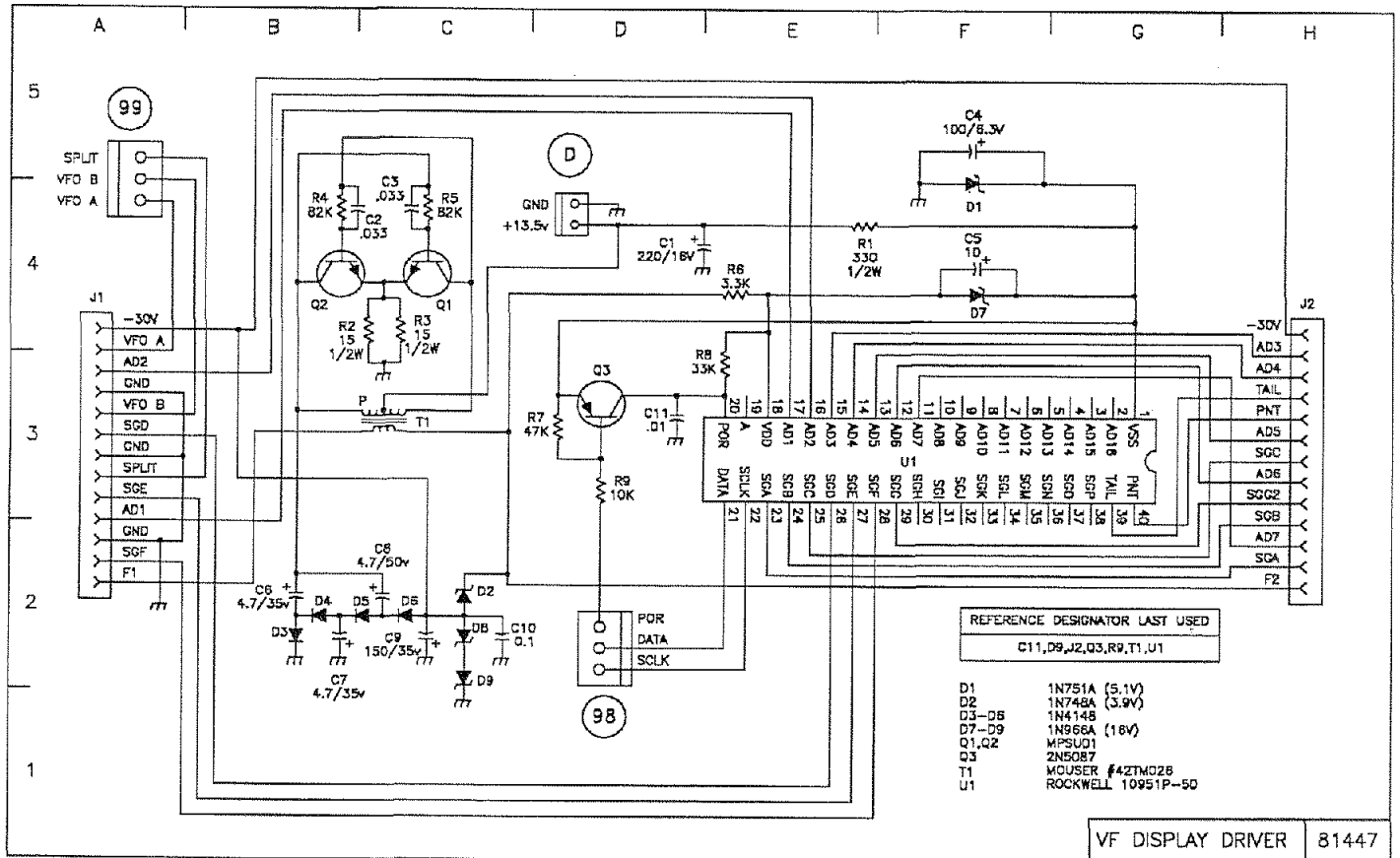

FIGURE 6-58. 81447 VF DISPLAY DRIVER BOARD SCHEMATIC

6-21 VF DISPLAY BOARD (81448)

This board contains a seven digit seven segment vacuum fluorescent display DISP1 and the required pull-up resistors to drive the digits and segments. Also on this board is an array of 3 LEDs used to annunciate the various display modes currently in use.

The display segments (SGA-SGG, SGG2, PNT, TAIL) and digits (AD1-AD7) are driven by integrated circuit U1, located on the 81447 VF Display Driver board. The display is driven in a multiplexed mode with only one digit being turned on at a time. Bias (-30 volts) for the display and driver circuits is provided by a dc-to-dc convertor, also located on the VF Display Driver board.

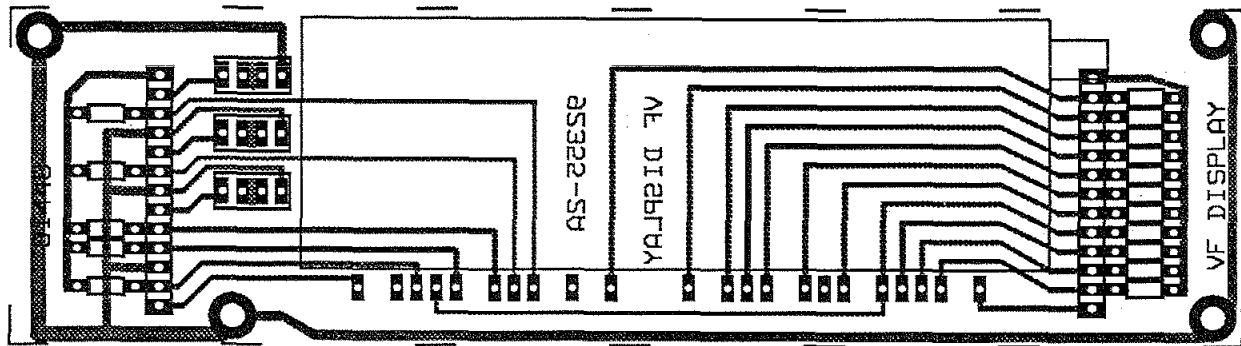

FIGURE 6-59. 81448 VF DISPLAY BOARD CIRCUIT TRACE

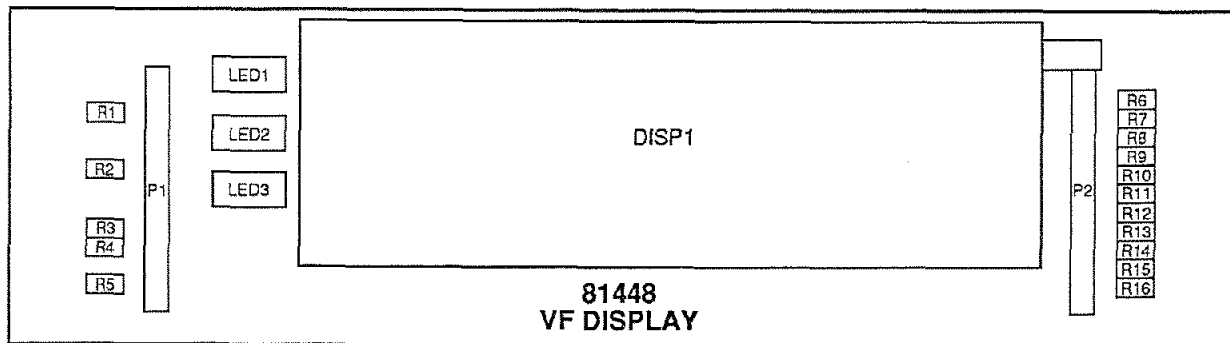

FIGURE 6-60. 81448 VF DISPLAY BOARD COMPONENT LAYOUT

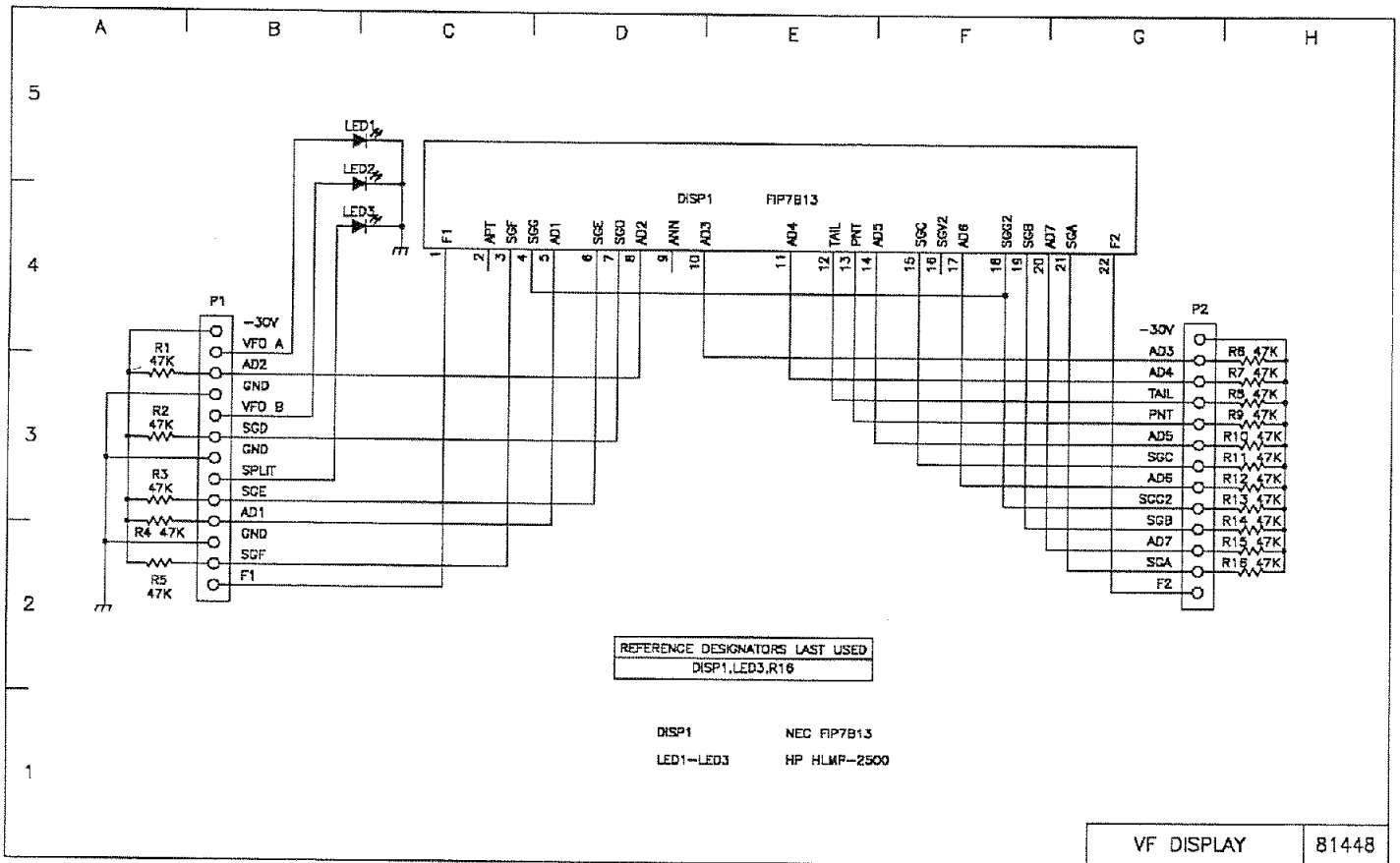

FIGURE 6-61. 81448 VF DISPLAY BOARD SCHEMATIC

6-22 DC POWER BOARD (81328)

This assembly connects to the rear panel fuse F1 (AGC 25 Fast Blow), which in conjunction with D1 provides short circuit and reverse polarity protection. Current shunt resistor R1 is used to sample the final amplifier collector current. Transistor Q1 along with R2 and C2 form a slow turn on delay circuit for controlling DC power relay RLY1. This relay, which is controlled by the front panel POWER switch, connects 13.5 Volts DC from the external power supply to the main 13.5 Vdc power buss in the transceiver.

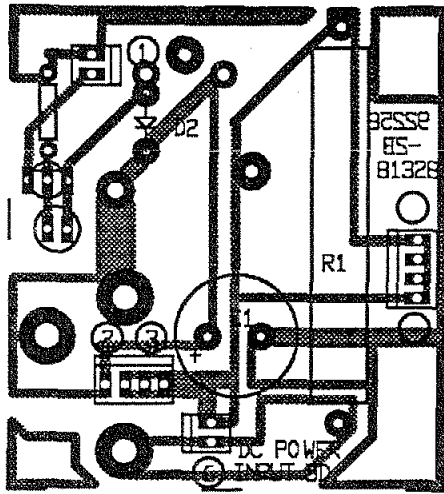

FIGURE 6-62. 81328 DC POWER BOARD CIRCUIT TRACE

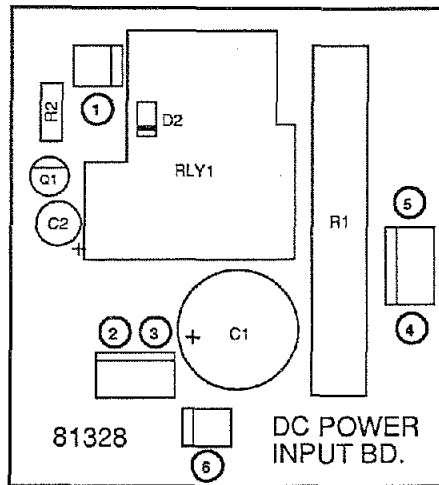

FIGURE 6-63. 81328 DC POWER BOARD COMPONENT LAYOUT

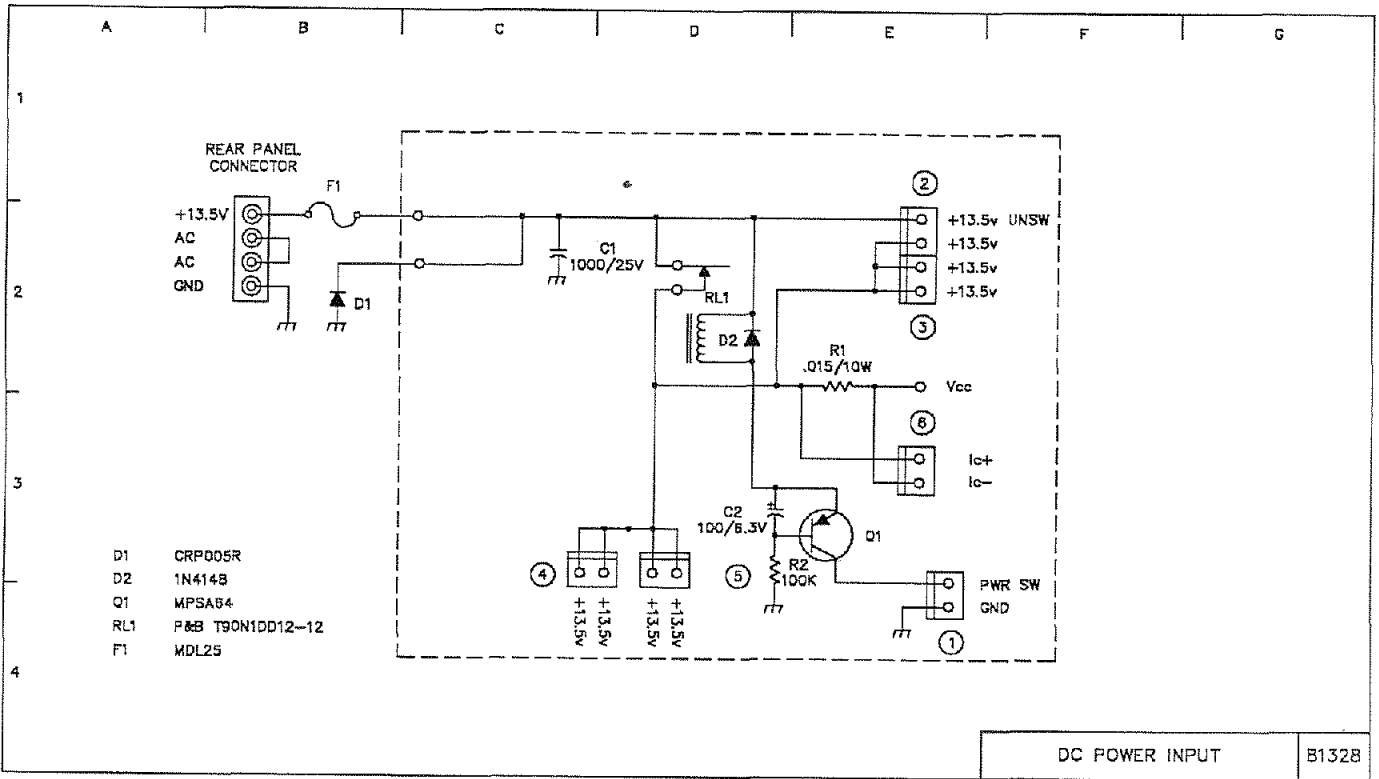

FIGURE 6-64. 81328 DC POWER BOARD SCHEMATIC

6-23 VOICE READOUT BOARD (81361)

This assembly contains the circuitry required to generate a synthesized voice readout of the OMNI V's operating frequency. The heart of the synthesizer is U7, which generates the synthesized voice from data stored in Eproms U1 through U4. In the basic voice option, only Eprom U1 is required. The remaining sockets are for possible future expansion. The clock circuit for U7, which oscillates at about 640 kHz, consists of C7, C8, C9, and L1.

The digitized audio output from U7 is fed to U10, which comprises an active low pass filter with a cutoff frequency of about 6 kHz. This filter removes the high frequency digitizing components and makes the synthesized voice sound more natural. The output of U10 then goes to a trimmer control, R13, which sets the output level going to the audio circuits of the OMNI V.

Integrated circuit U5 is used to latch the high order address lines (A9-A16) going to Eproms U1-U4. U6 is used as an address decoder to select the appropriate Eprom depending on address lines A15, A16.

Integrated circuit U8 is used to latch the data byte coming from the microprocessor located on the 81442 Logic Board. To address the voice readout, the DS line is set high while a negative strobe pulse is applied to the input of U9, which inverts this pulse before sending it to both U8 and U7. This initiates the generation of the speech word selected by the latched data byte stored in U8. When U7 begins to generate speech, it sets the BUSY line low. This line, which is buffered by U9b and U9a, tells the microprocessor to stop sending data until the voice readout is finished, at which time the BUSY line returns high.

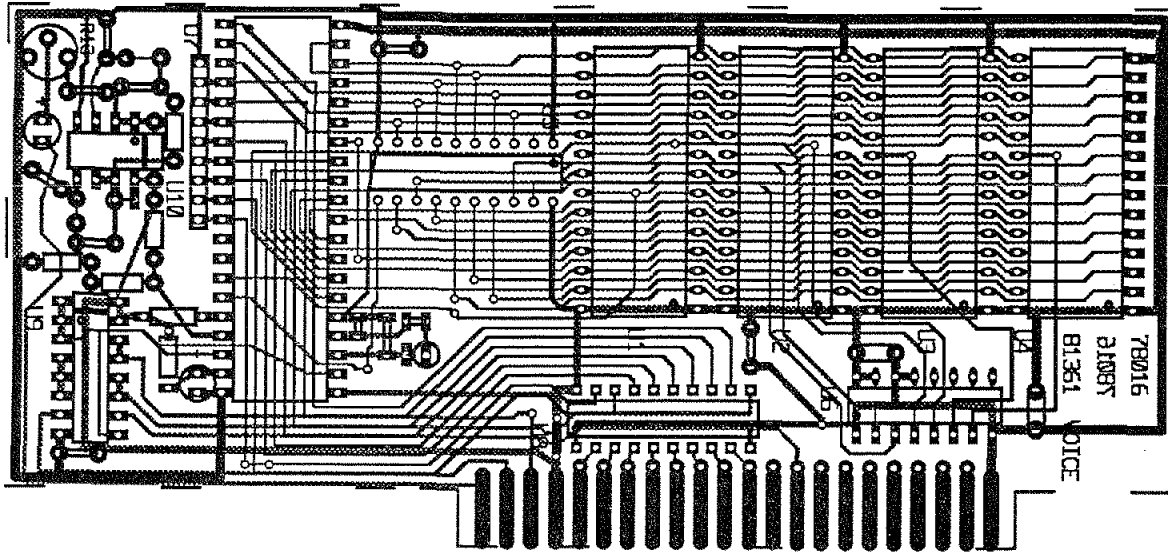

FIGURE 6-65. 81361 VOICE READOUT BOARD CIRCUIT TRACE

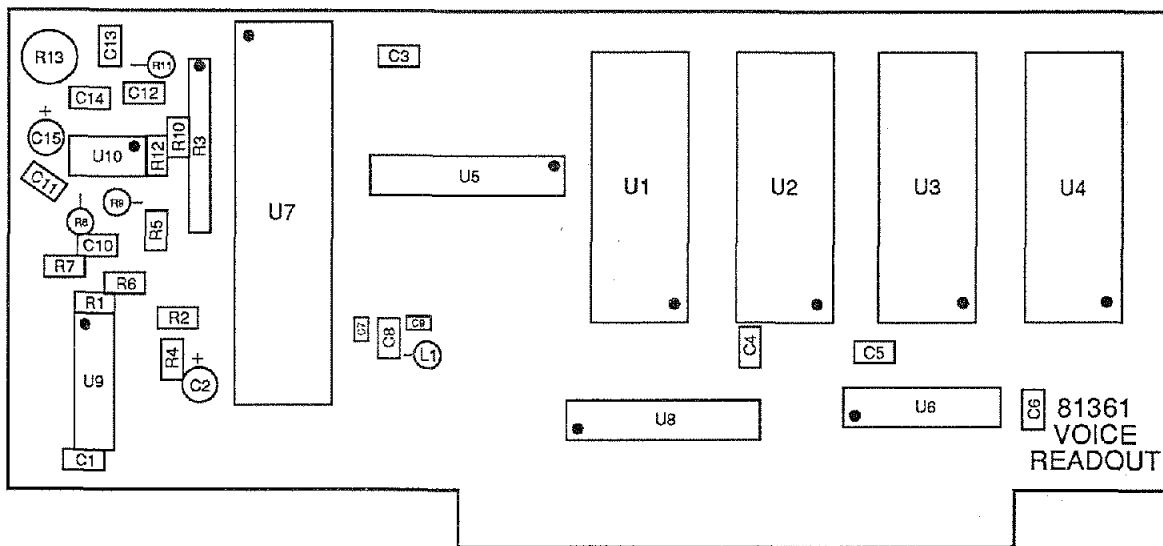
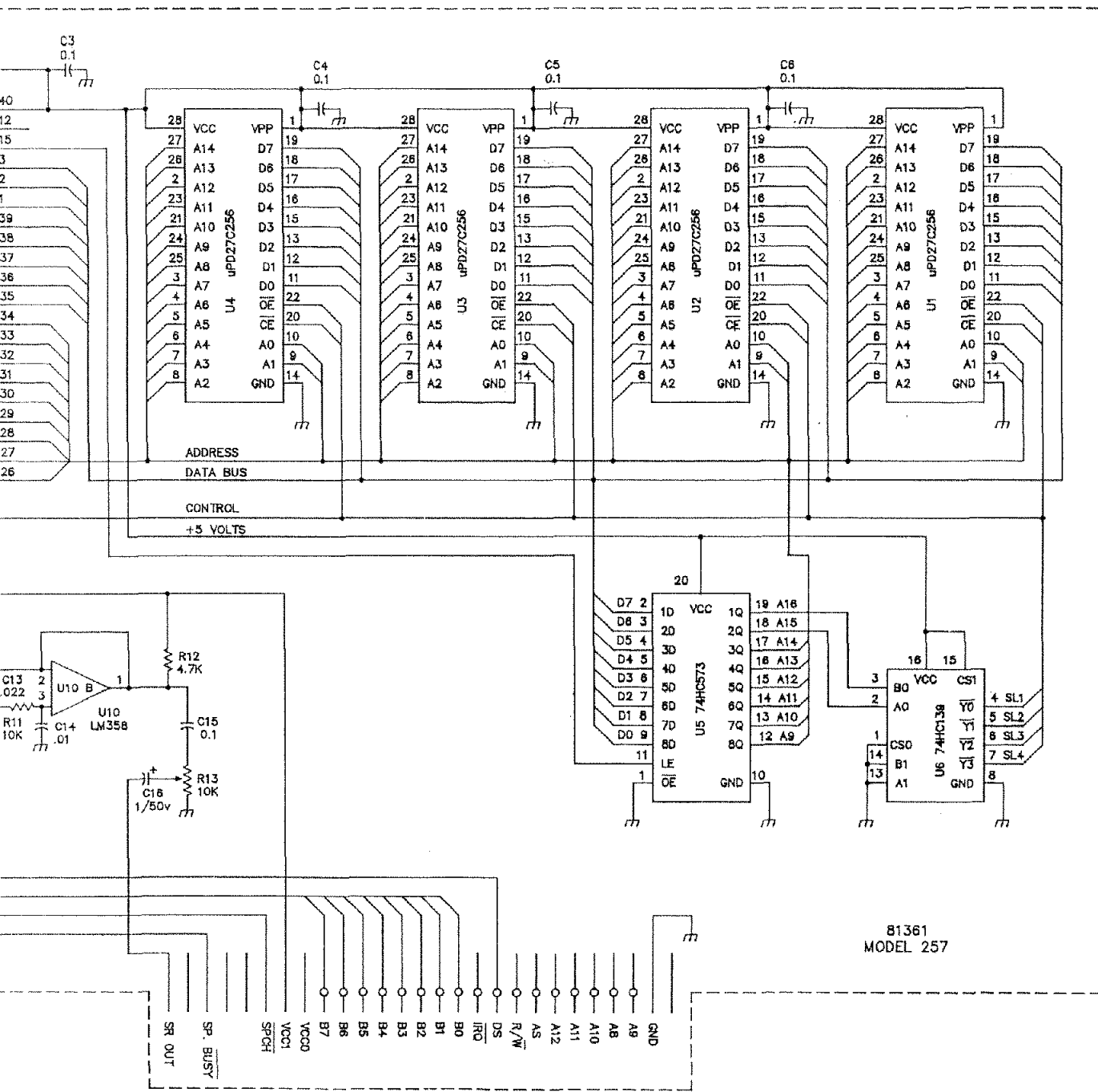

FIGURE 6-66. 81361 VOICE READOUT BOARD COMPONENT LAYOUT



81361
MODEL 257

6-97/6-98 blank

6-24 RS232 CONNECTOR BD. (81425)

This board contains a Female DB-25 connector for communicating with an external computer via a simple 4-wire cable. The serial RS232 and TTL level signals from the 81442 Logic Board are routed to connector B. Connector 8 provides the band control information coming from the 81455 Low Pass

Filter board. These six filter select lines go directly to connections on the DB-25 connector and are used to control an external Linear Amplifier. Connector E contains +5 volts, ground and phase signals which are used with an optional remote rotary encoder.

The connections to the DB-25 connector are shown below in TABLE 6-1.

TABLE 6-1. RS232 CONNECTOR PINOUTS

<u>DB-25 PIN NO.</u>	<u>FUNCTION</u>
1	CHASSIS GROUND
2	TxD OUTPUT (RS232 LEVELS)
3	RxD INPUT (RS232 LEVELS)
4	NO CONNECTION
5	NO CONNECTION
6	ENCODER PHASE #2
7	SIGNAL GROUND
8	ENCODER PHASE #1
9	NO CONNECTION
10	BAND #1 OUTPUT (160 Meters)
11	RxD INPUT (TTL LEVELS)
12	NO CONNECTION
13	NO CONNECTION
14	CHASSIS GROUND
15	BAND #6 OUTPUT (10 Meters)
16	+5 VOLTS
17	BAND #5 OUTPUT (15/12 Meters)
18	TxD OUTPUT (TTL LEVELS)
19	NO CONNECTION
20	NO CONNECTION
21	BAND #4 OUTPUT (20/17 Meters)
22	NO CONNECTION
23	BAND #3 OUTPUT (40/30 Meters)
24	BAND #2 OUTPUT (80 Meters)
25	NO CONNECTION

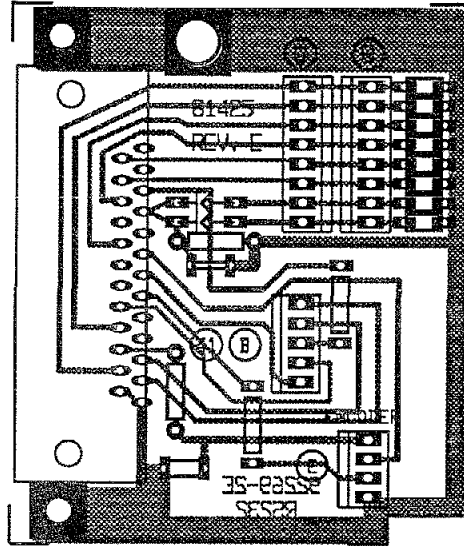

FIGURE 6-68. 81425 RS232 CONNECTOR BOARD CIRCUIT TRACE

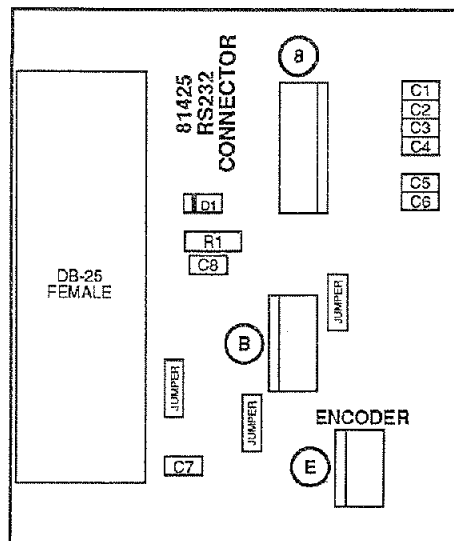

FIGURE 6-69. 81425 RS232 CONNECTOR BOARD COMPONENT LAYOUT

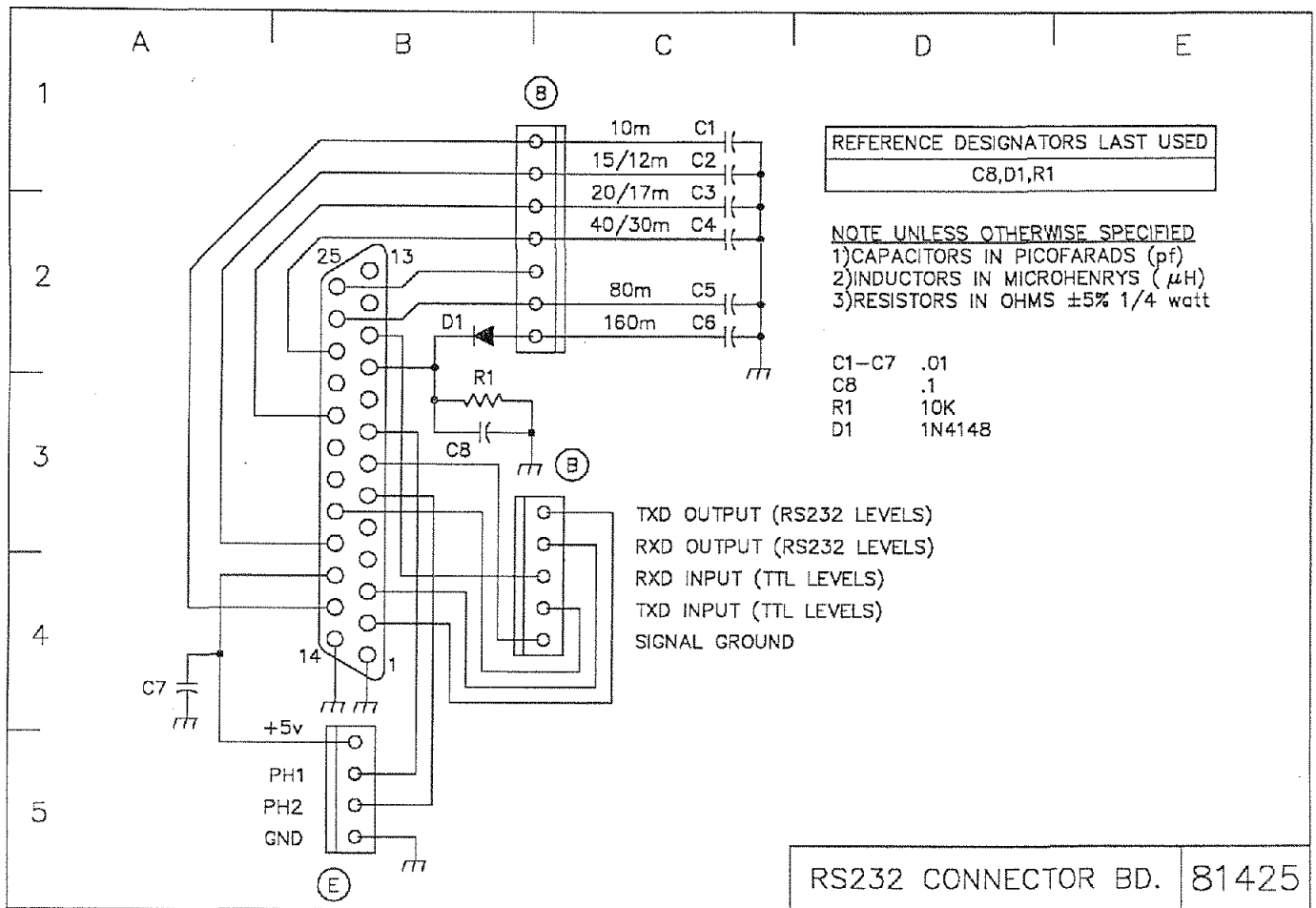

FIGURE 6-70. 81425 RS232 CONNECTOR BOARD SCHEMATIC

Table 6-2, below, lists the command codes used to control the OMNI V. For further information refer to the programming information supplied with your software package.

TABLE 6-2. RS232 OMNI V COMMAND CODE CHART

KEY FUNCTION	CHARACTER	ASCII CODE	KEY FUNCTION	CHARACTER	ASCII CODE
160M	0	30	CW	G	47
80M	1	31	TUNE	H	48
40M	2	32	2.4 FILTER	I	49
30M	3	33	1.8 FILTER	J	4A
20M	4	34	.50 FILTER	K	4B
18M	5	35	.25 FILTER	L	4C
15M	6	36	NAR FILTER	M	4D
12M	7	37	UP	N	4E
10A	8	38	DOWN	O	4F
10B	9	39	VFO -> M	P	50
10C	:	3A	M -> VFO	Q	51
10D	;	3B	VCE	R	52
CLR/CLK	<	3C	A. TEST ON	S	53
REV	=	3D	A. TEST OFF	T	54
MT	>	3E	CR. STATUS	U	55
A=B	?	3F	VFO STATUS	V	56
A/B	@	40	MEM. DUMP	W	57
FAST	A	41	RMTUNE UP	X	58
SPLIT	B	42	RMTUNE DN	Y	59
FM	C	43	CR. FREQ.	Z	5A
FSK	D	44			
LSB	E	45			
USB	F	46			

Ten-Tec, Inc.
1185 Dolly Parton Parkway
Sevierville, TN 37862
Repair Service: (865) 428-0364

LIMITED WARRANTY AND SERVICE POLICY, U.S.A. AND CANADA

Ten-Tec, Inc., warrants this product to be free from defects in material and workmanship for a period of one (1) year from the date of purchase, under these conditions:

1. THIS WARRANTY APPLIES ONLY TO THE ORIGINAL OWNER. It is important that the warranty registration card be sent to us promptly.
2. READ THE MANUAL THOROUGHLY. This warranty does not cover damage resulting from improper operation. Developing a thorough understanding of this equipment is your responsibility.
3. IF TROUBLE DEVELOPS we recommend you contact our customer service group direct at the address or phone number shown above. It has been our experience that factory direct service is expeditious and usually results in less down-time on the equipment. Some overseas dealers do offer warranty service and, of course, have our complete support.
4. EQUIPMENT RETURNED TO THE FACTORY must be properly packaged, preferably in the original shipping carton(s). You pay the freight to us and we prepay surface freight back to you. Canadian customers must have proper customs documentation sent with incoming repair equipment. Duties or fees charged due to improper documenting are the responsibility of the owner of the equipment.
5. EXCLUSIONS. This warranty does not cover damage resulting from misuse, lightning, excess voltages, polarity errors or damage resulting from modifications not recommended or approved by Ten-Tec. In the event of transportation damage, a claim must be filed with the carrier. Under no circumstances is Ten-Tec liable for consequential damages to persons or property caused by the use of this equipment.
6. TEN-TEC RESERVES the right to make design changes without any obligation to modify equipment previously manufactured, or to notify owners of changes to existing equipment.
7. THIS WARRANTY is given in lieu of any other warranty, expressed or implied.

SERVICE OUTSIDE OF THE U.S.A. OR CANADA

Many of our international dealers provide warranty service on the equipment they sell. Many of them also provide out of warranty service on all equipment whether they sold it or not. If your dealer does not provide service or is not conveniently located, follow the procedure outlined above. Equipment returned to us will be given the same attention as domestic customers but roundtrip freight expense, customs and broker fees will be paid by you.

Part no. 74244

