

**POWER-MITE PM3 and PM3A**

**DESCRIPTION**

The Power-Mite 3 and 3A are self-contained CW transceivers covering 40 and 20 meters. The receiver is comprised of a variable oscillator operating on the received frequency, a mixer and high gain audio amplifier. The received signal is converted directly to audio where a filter eliminates undesirable signals, and then amplified to headphone level by a high gain audio amplifier. The variable oscillator covers 7.0 to 7.3 MHz for 40 meter operation and is doubled to 14.0 to 14.6 MHz to cover 20 meters.

The transmitter, driven from the same oscillator-multiplier used for receiving, has an isolation stage, driver and push-pull final amplifier. It is keyed in the buffer stage. The output circuit is a Pi network to match 50-75 ohm unbalanced loads. A side-tone oscillator with variable frequency and volume is keyed along with the buffer stage.

**SPECIFICATIONS**

Frequency range:	BAND	RANGE
	40	7.0 - 7.3 MHz
	20	14.0 - 14.6 MHz

Size: 4" H, 10-1/8" W, 7-1/2" D. Shipping weight: 4lbs.  
Finish: Baked enamel with Cynolac sidepanels and wood grain inserts  
Power: 12 Volts 30 ma. on receive, 480 ma. on transmit

Semiconductor devices: 1 Dual gate MOSFET  
1 Integrated circuit  
8 Silicon transistors (10 in PM3A)

Types of reception: CW - SSB - AM

Sensitivity: Less than one microvolt provides readable signal

Antenna input: 50-75 ohms

Selectivity: 2 KC at 6 db down points

Audio: Output impedance - 1000 ohms, frequency response - +/-3 db 200 Hz - 2500 Hz

Frequency stability: Less than 100 Hz drift

Transmitter: Power-5 watts input, output impedance 50-75 ohms, Pi network

Headphones: Front panel tip jacks are provided

Key: Phono jack is provided on rear apron

## **INSTALLATION**

### **UNPACKING**

Open carton carefully to prevent damage. Remove packing material and equipment from the carton. Check all knobs, switches, etc. to see that they operate properly. Any claims for damage should be filed promptly with the transportation company.

### **EXTERNAL CONNECTIONS**

**ANTENNA:** The transceiver is designed to operate into a 50 ohm unbalanced transmission line. Many of the popular beam and dipole antennas using 50-75 ohm transmission lines will give excellent results. Station antennas terminating in other than 50-75 ohms will require an impedance matching device similar to the Model AO5 antenna tuner.

### **CAUTION**

To not subject the antenna input to RF exceeding 10 volts. Excessive RF may be encountered if operated in conjunction with high power transmitters if the receiving antenna is not disconnected and/or shorted during transmitting.

### **CONTROLS**

VOL	Adjusts the level of the audio amplifier.
RECV	Resonates the input circuit of the mixer. Must be adjusted each time band is changed.
40,20	Band switch. All three switches must be thrown when changing bands.
ON-OFF	Power switch.
TRAN-RECV	Used to transfer the antenna from the transmitter to receiver in the PM3. On the PM3A, with break-in keying, this switch is used as a manual transmit receive switch. If the break-in feature is not desired, this switch will actuate the antenna relay.
TUNE-OPR	Activates transmitter for tune-up.
TUNE	Resonates final amplifier
LOAD	Adjusts output impedance for correct match.

### **OPERATION**

Set the front pannel controls as follows:

VOL	Mid rotation (12 o'clock)
REC	Mid rotation (12 o'clock)
40,20	40 all three switches)
ON-OFF	OFF
TRANS-RECV	RECV
TUNE	11 o'clock
LOAD	Full C.W.
TUNE-OPR	OPR

### **40 METER OPERATION**

Connect a 12 volt 500 milliampere D.C. source to the power socket on the rear apron. Connect plus 12 volts to the center of the connector and minus 12 volts to ground or shield. Attach headphones, key and antenna. Turn the power switch on, tune in a signal and peak the RECV control for maximum sensitivity. This tunes the input circuit to resonance. It will have to be re-peaked when going from one end of the hand to the other, or when changing bands.

## **ALIGNMENT PROCEDURE PM3/PM3A**

The PM3 and PM3A consist of an oscillator, used for both transmitting and receiving, a buffer/doubler, receiving mixer, high gain audio amplifier, transmitter and side-tone. The master tuning oscillator operates between 7.0 and 7.3 MHz. The signal is fed to a buffer/doubler stage. It is used straight through on 40 meters for injection into the mixer and transmitter, and is doubled to 14 MHz for injection into the mixer and transmitter for 20 meter operation. The receiving mixer is resonated with a front panel control. The audio output passes through a lowpass filter and high gain audio amplifier to the phones. The transmitter has an untuned buffer stage, a driver fixed tuned with internal trimmers and a push-pull final amplifier.

### **OSCILLATOR ALIGNMENT**

#### **Set the dial to 7.0 MHz**

Using a calibrated receiver set at 7.0 MHz, for reference, adjust the bottom slug in the shield can located on the V01 board until the signal is heard on the receiver. Use the alignment tool provided. Insert the long end through the first hex slug into the bottom hex slug. This will calibrate the transceiver at the low frequency end of the scale. Rather than use an inexpensive trimmer with possible drift, or a high quality trimmer and raise the price, the high frequency calibration was not made adjustable.

#### **Buffer/Doubler**

The buffer/doubler and side-tone are located on the AC6 board next to the main oscillator. Set the dial to 14.050 MHz. Place all three band switches at the 20 position. Switch to tune and adjust the coil on the board for maximum output on 20 meters. The adjustment should hold over the complete CW portion. If maximum output is desired in the phone portion, the coil should be readjusted.

#### **Transmitter Alignment**

With the switches in the 20 meter position and the transmitter on tune, adjust the trimmer next to the push-pull final for maximum output on 20 meters. Place all three switches to 40 meters and adjust the other trimmer for maximum output on 40 meters. This trimmer will be at maximum capacity when properly tuned. Final resonate and load are handled by front panel controls.

#### **Mixer**

The antenna coil is resonated by a front panel control and does not require alignment. The audio coil can be adjusted for great bandwidth, if desired. It has been set for maximum inductance or lowest cut-off frequency. To raise the cut-off frequency, adjust the slug into the coil.

### **TRANSMITTER ALIGNMENT**

Start with Load Control To Full C.W. Turn TRAN-RECV switch to TRANS and TUNE-OPR switch to TUNE. Turn the TUNE control for a dip in the final current. Start with TUNE control full C.W. and use the first dip found when tuning C.C.W. It is possible to find a false dip at maximum C.C.W. which would indicate the amplifier is doubling. Adjust the LOAD control C.C.W. to increase the load. As the loading is increased, re-dip the TUNE control. Continue loading and tuning for maximum output or until the dip becomes shallow and broad. Return the TUNE-OPR switch to operate. TRAN-RECV switch to RECV. Throw the TRAN-RECV switch to TRAN to transmit and RECV for receiving. With the PM3A it is only necessary to hit the key to transmit.

Short periods of operation off resonance into a short, into an open or high SWR load should not harm the final transistors. Prolonged operation in any of the above conditions may result in excessive dissipation and transistor failure.

### **20 METER OPERATION**

Place all three band switches to 20. Proceed as for tune-up under 40 meter operation to peak the RECV control near maximum C.C.W. for maximum sensitivity. Follow the same procedure for transmitter tune up as in 40 meter operation.

### **SIDE-TONE**

The built-in side tone operates when the transmitter is keyed to provide a monitor while sending. The frequency and volume are adjusted by thumb pots on the circuit board. They have been set at the factory. They may be adjusted to individual taste by removing the top of the case. The adjustment potentiometers are located next to the main oscillator board.

### **BREAK-IN KEYING (PM3A ONLY)**

Antenna change-over, receiver mute, ect. Are accomplished automatically when the key is closed. An adjustable hold circuit keeps the relay closed between letters and words. The hold time is adjusted with a thumb pot located on the relay board inside the case. The TRAN-RECV switch overrides the hold circuit and will provide manual operation for transmit and RECV.

**NOTE:** The Power-Mite 3 and 3A have been designed with sufficient overload protection for all but extreme cases. Should any interference occur, such as a near-by local broadcast station, a trap in the antenna lead will eliminate it.

### **WARRANTY**

This equipment is guaranteed to be free of defects in workmanship and material for one Year after date of purchase.

If, at any time up to 5 years after expiration of this warranty, any failure is experienced, send the unit to us, prepaid, with \$1.00 It will be placed in proper operating condition and returned postpaid.

## ADDENDUM

### INTERFERENCE REDUCTION

Interference from nearby broadcast stations can be eliminated by a simple high-pass filter in series with the mixer antenna leads. Connect the filter in Fig. 1 between the "A" and "G1" terminals on the MX1 board and the antenna.

Foreign phone stations in the 12-16 MHz range may be heard when resonating the mixer coil. This is due to mixer overload. The mixer should be carefully resonated at 14 MHz in order to reduce these signals as much as possible to minimize the chance of overload. Additional selectivity such as an antenna tuner is helpful.

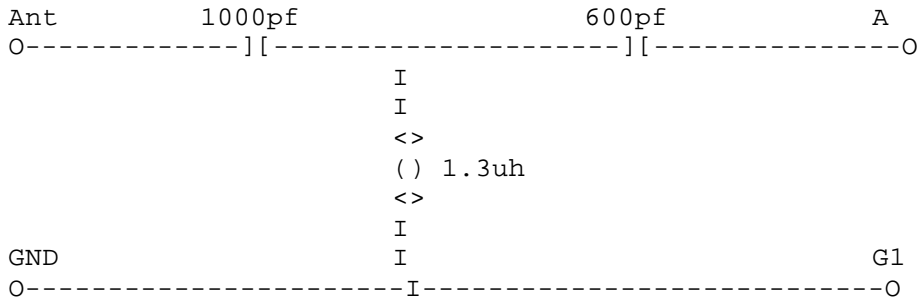

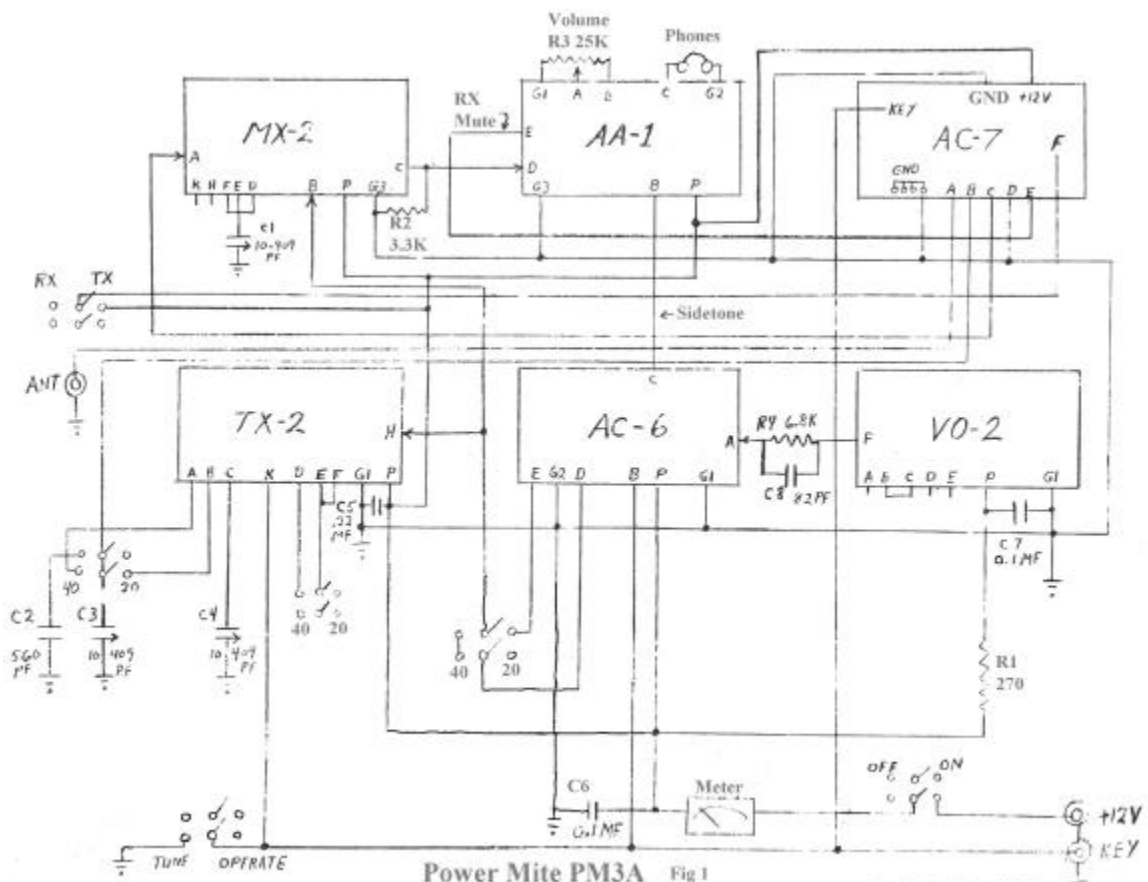

Power Mite PM3A Fig 1

Reproduced by NICT on 3/1/1988

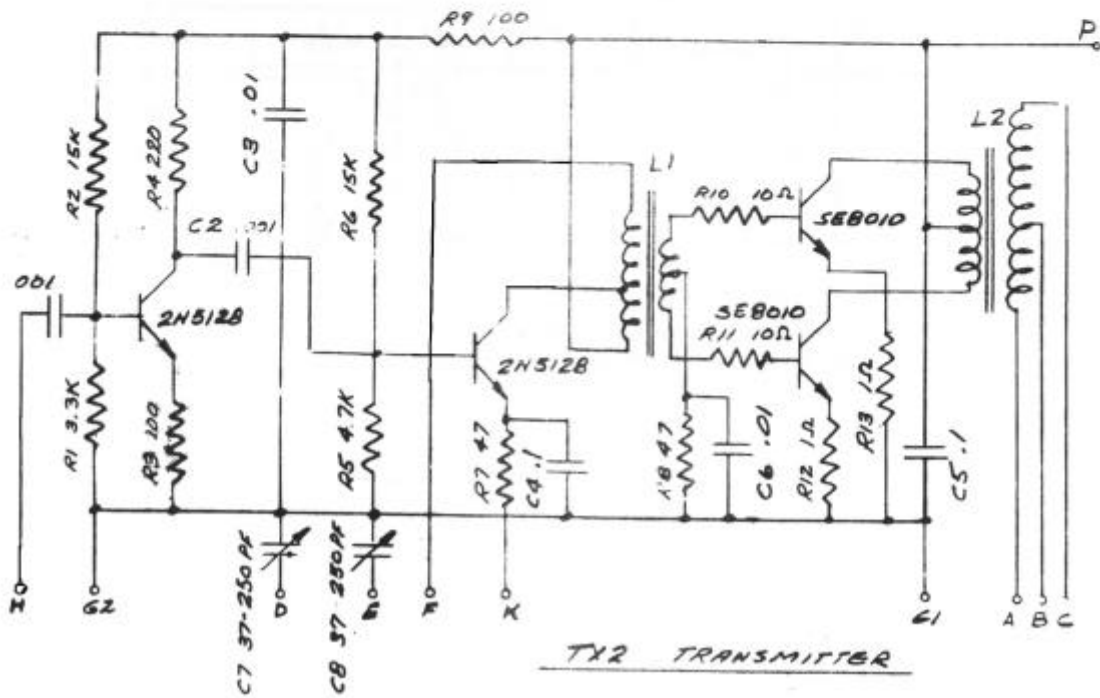
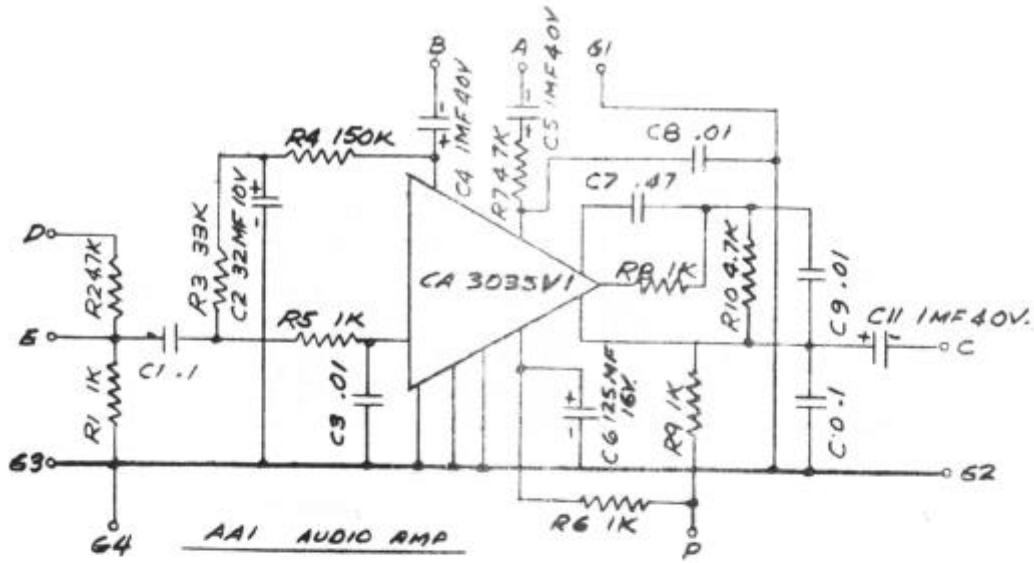

Power Mite PM3A Fig 2

Reproduced by NTLT on 3/3/1999

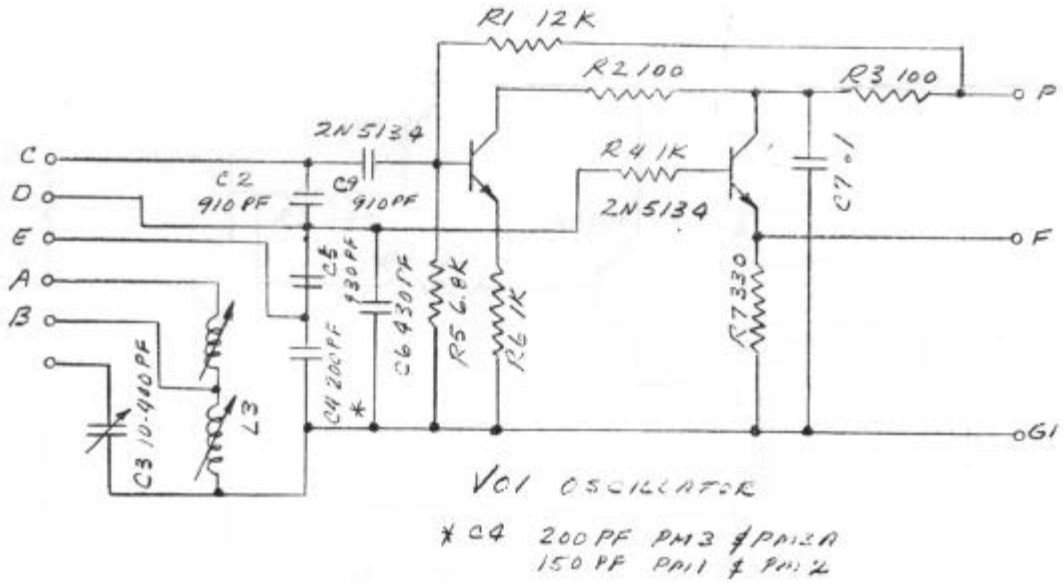
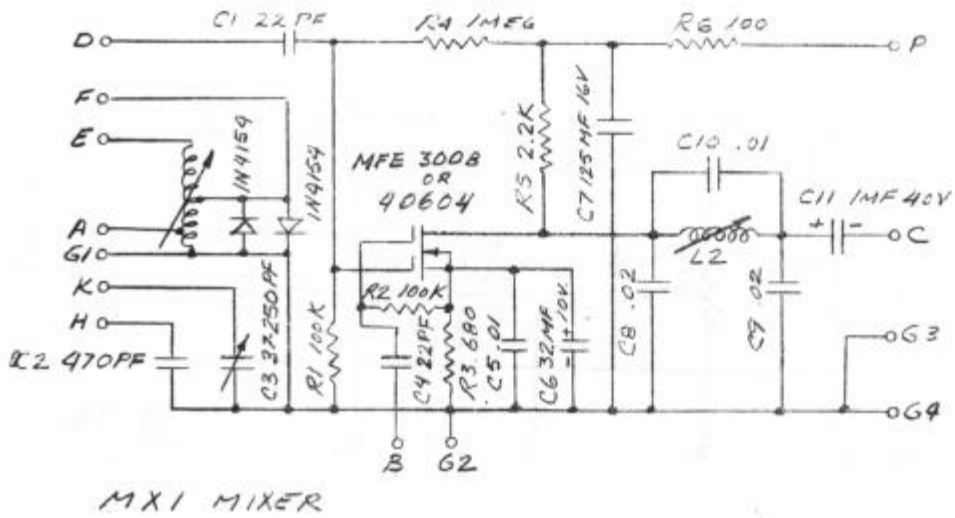

Power Mite PM3A Fig 3

Reproduced by N7LT on 3/3/1988



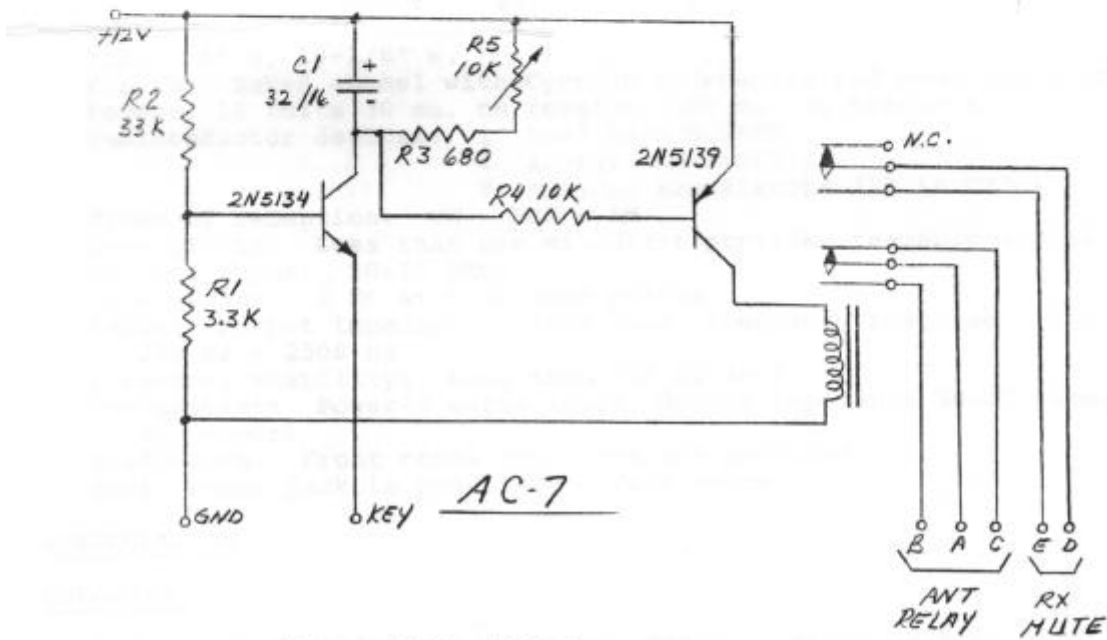
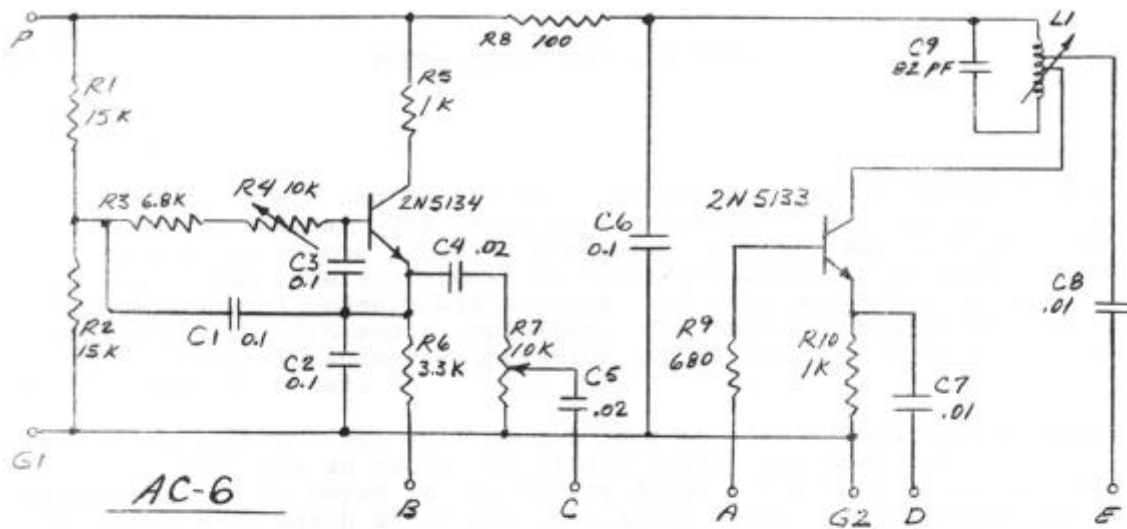

Power Mite PM3A Fig 4

Reproduced by N7LT on 3/3/1999