

**TEN-TEC**  
**TEN - TEC**

**OPERATOR'S  
MANUAL**

**Model  
544**



CONTENTS

SECTION	TITLE	PAGE
I	INTRODUCTION	1- 1
	CONDENSED OPERATING INSTRUCTIONS	1- 1
	SPECIFICATIONS	1- 2
II	DETAILED OPERATING INSTRUCTIONS	2- 1
	Rear Panel Connections	2- 1
	Front Panel Controls	2- 4
	General Operating Notes	2- 6
	Full Ten Meter Coverage	2- 7
	Operating Hints	2- 8
	An Important Message	2- 9
III	ALIGNMENT AND SERVICE	3- 1
	Disassembly	3- 1
	Pilot Lamp Replacement	3- 2
	Fuse Replacement	3- 2
	MAIN CHASSIS WIRING	3- 4
	FIGURE 1 - TOP VIEW	3- 6
	FIGURE 2 - BOTTOM VIEW	3- 7
	R.F. AMPLIFIER 80166	3- 8
	VFO 80350	3-10
	DIGITAL READOUT	3-14
	Theory of Operation	3-14
	Servicing Hints	3-15
	LOGIC BOARD 80348	3-15
	TIME BASE-PRE AMP 80346	3-16
	TX-RX MIXER 80287	3-20
	I.F.-AGC 80279	3-22
	AUDIO AMPLIFIER 80274	3-24
	SSB GENERATOR 80282	3-26
	BANDPASS FILTERS 80291	3-29
	LOW LEVEL DRIVER 80285	3-30
	FINAL AMPLIFIER 80276	3-32
	LP FILTER 80307	3-34
	SWR - ALC 80284	3-35
	OT-TR ASSEMBLY 80281	3-37
	CONTROL BOARD 80280	3-39
	WARRANTY AND SERVICE POLICY	Insert

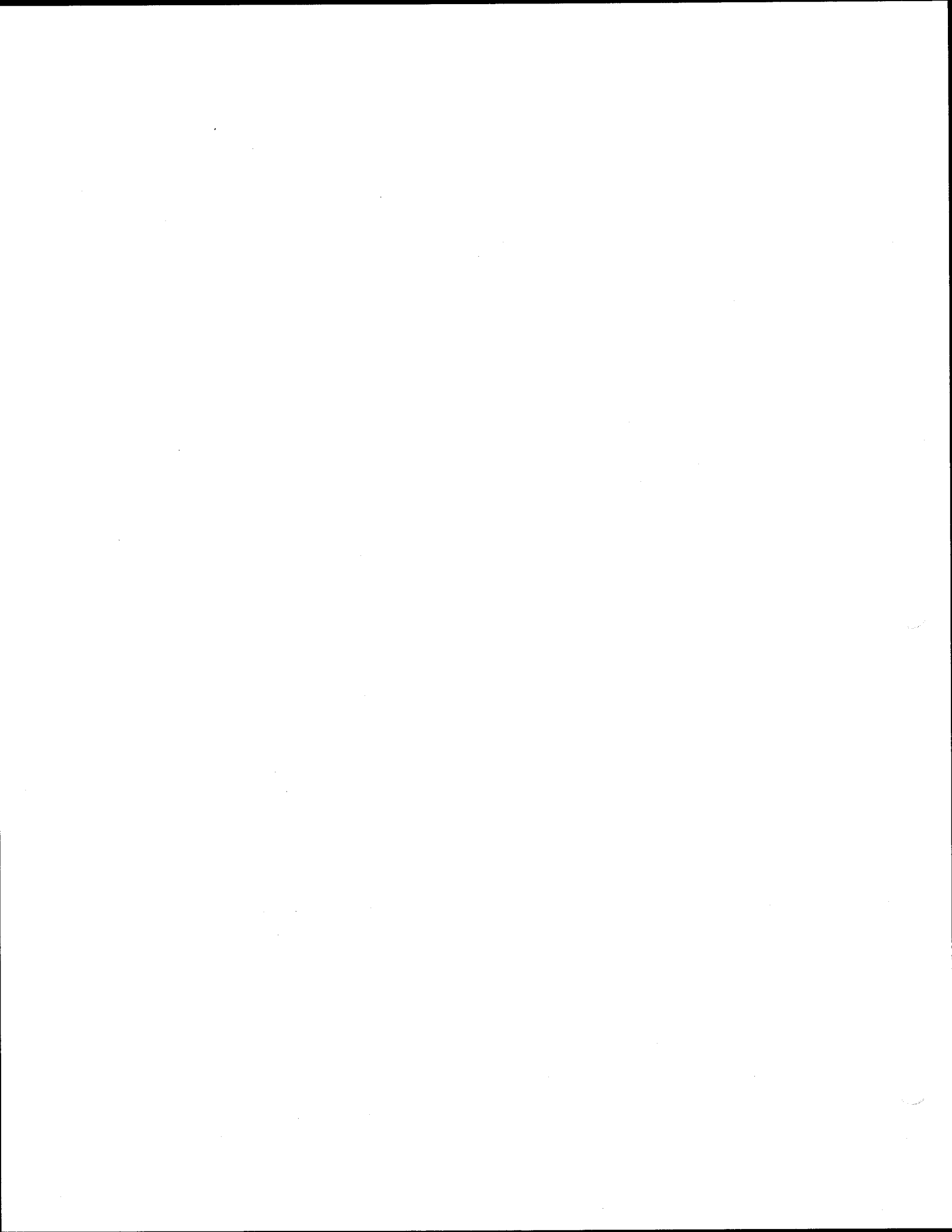

## SECTION I

### INTRODUCTION

Model 544 is a medium power transceiver employing the latest techniques in solid state technology. Unique balun type transformers couple each rf stage insuring efficient energy transfer without the need to resonate or tune. Individual low pass output filters for each band reduce transmitted harmonic and TVI components to a low value.

The transceiver is extremely versatile. Although essentially a fixed station, it is equally at home when used mobile or portable. It operates from 12-14 volts DC or from 115/230 volts AC with an external power supply.

As you become more familiar with the operation of your transceiver you will value the built-in operating conveniences more and more. "Tune-O-Matic" band changing completely eliminates transmitter tune-up. Frequency of operation is easily and accurately determined from the built-in counter and digital readout. The panel meter automatically switches from an "S" meter to an SWR meter when transmitting. The normal sideband is selected, whether it be upper or lower, according to the band in use. Indicator light emitting diodes (LEDs) are provided for offset tuning (OT) and automatic level control (ALC). These are just a few of the many features you will enjoy. And a full array of accessories is available that further enhances the overall enjoyment and flexibility. All in all, transceiver is designed for active, serious amateurs.

### CONDENSED OPERATING INSTRUCTIONS

The following instructions will enable the operator to quickly place the Model 544 in operation. For a more detailed description of the controls and their functions, refer to SECTION II.

#### REAR APRON CONNECTIONS

**POWER** - Use a 12 to 14 VDC power source capable of delivering 18 amperes, well regulated. When powering from either a TEN-TEC Model 252G or 262G power pack, interconnect units with the cable supplied. When other supplies or a battery are used, pin connections to the power socket are:

Pins 2 & 3 - Power Switch; Pin 1 - Negative 12-14 volts (GND);  
Pin 4 - Positive 12-14 VDC.

Power Switch contacts, pins 2 and 3, should not be used to switch 12-14 VDC directly, due to switch contact ratings and voltage drop across the switch. If it is desired to switch power on and off from the front of the transceiver, use these pins to switch the primary AC voltage in cases where an AC power pack is used, or to actuate an intermediate relay with sufficient current handling contacts in 12-14 VDC installations.

For minimum cable loss, use number 12 or 14 gauge wire for the plus and minus leads. Smaller gauge wire can be used for the switch leads.

**ANTENNA** - Connect a 50 to 75 ohm, unbalanced resonant antenna, such as a beam, dipole or vertical. Balanced antennas and those with higher impedances should be matched with an antenna tuner or similar network.

**T/R-REC SWITCH** - For normal transceiver operation, position this switch in the T/R mode. If an external amplifier or a separate receiving antenna is to be used, refer to the detailed instructions in SECTION II.

**MIC** - For ssb operation, plug a high impedance dynamic, ceramic or crystal microphone into this jack. Transistor amplified microphones can be used also, providing output level is adjusted to a low enough value so as not to overload the microphone channel. Use standard 1/4" stereo type phone plug. Tip to PTT switch; band to microphone signal; barrel to ground. Use shielded cable to prevent rf pickup. PTT switch should be SPDT type which shorts

out the microphone in the receive mode.

KEY - For cw operation, connect a straight key, bug or electronic keyer to this jack. Electronic keyers should be of the reed relay type or with low positive voltage switching transistors (NPNs). A low resistance and/or low saturation voltage from the transistor keyed keyer is required on the KEY line for proper transmitter keying.

#### FRONT PANEL CONTROLS

##### INITIAL CONTROL SETTINGS - CW OR SSB

- 1.) Select desired band with BAND switch. If working ten meters, select desired 500 kHz segment.
- 2.) Tune dial to frequency of operation.
- 3.) Set ALC control fully clockwise.
- 4.) Push POWER knob, located on AF control, in.
- 5.) Rotate MODE switch to LOCK position.
- 6.) Rotate DRIVE control until ALC indicator lights.
- 7.) Observe SWR reading on meter. For efficient operation SWR should be less than 3 to 1. If it is not, make alteration to antenna system to reduce SWR.
- 8.) Switch MODE switch to desired mode -- ssb or cw. For cw operation, the setting of the DRIVE control arrived at in step 6 above is the correct setting. In ssb, readjust DRIVE control so that ALC indicator just lights on voice peaks.
- 9.) Reak RESONATE control for maximum receiver sensitivity.

#### SPECIFICATIONS

##### GENERAL

FREQUENCY COVERAGE - 3.5 to 4.0, 7.0 to 7.5, 14.0 to 14.5, 21.0 to 21.5, 28.0 to 28.5, 28.5 to 29.0, 29.0 to 29.5, 29.5 to 30.0 MHz. (Crystals not supplied for last two segments.)

VFO FREQUENCY STABILITY - Less than 15 Hz change per degree F, averaged over a 40° change from 70° to 110°, after 30 minute warmup. Less than 10 Hz change from 105 to 125 VAC line voltage, when using a TEN-TEC supply.

FREQUENCY READOUT - 0.43" high LED numerals. Six digits. LSD 100 Hz. All digits red except LSD is green. One KHz markers on dial skirt.

TUNING RATE - Approximately 25 kHz per revolution of main tuning knob.

POWER REQUIREMENTS - 12 to 14 VDC regulated to 5% or better. 1 A. receive; 2 A. standby transmit; 18.5 A. maximum transmit.

SEMICONDUCTORS - 65 transistors, 38 diodes, 14 integrated circuits, 2 LEDs, 6 seven segment LED displays.

PC BOARDS - 10 plug-in types, 8 integral.

CONSTRUCTION - Rigid aluminum chassis and sub panels. Aluminum case. Cynolac side panels. Etched aluminum front panel, black textured top and sides.

DIMENSIONS - HWD 4-1/2" x 13-5/8" x 13".

NET WEIGHT - 12 lbs.

G  
N  
I  
C  
H  
E

RECEIVER

- SENSITIVITY - Less than 0.3 uV for 10 dB signal-plus-noise-to-noise ratio.
- SELECTIVITY - 8 pole lattice filter. 2.7 kHz bandwidth. 1.8 to 1 shape factor @ 6/60 dB.
- INTERMEDIATE FREQUENCY - 9 MHz.
- ANTENNA INPUT - Low impedance, unbalanced.
- AUDIO OUTPUT - 1 watt @ 8 ohms with less than 2% distortion. Built-in speaker, external speaker/phones jack.
- SPURIOUS RESPONSE - More than 50 dB down.
- AUTOMATIC GAIN CONTROL - For 100 dB change in input level, output changes less than 10 dB.
- OFFSET TUNING - Approximately  $\pm$  5 kHz, with pull-out defect switch and indicator LED.
- S-METER - Automatically switched on when receiving.
- CW FILTER - Optional plug-in accessory, Model 245. 150 Hz bandwidth centered at 750 Hz. Shape factor 7.2 to 1 @ 6/60 dB. Two selectable response curves.
- NOISE BLANKER - Optional plug-in accessory, Model 249. I-f type.

TRANSMITTER

- DC POWER INPUT - 200 watts.
- RF POWER OUTPUT - Typically 85 to 100 watts.
- OUTPUT IMPEDANCE - 50 to 75 ohms, unbalanced.
- MICROPHONE INPUT - High impedance crystal, ceramic, dynamic or transistor amplified.
- T/R SWITCHING - Push-to-talk on ssb. Complete break-in on cw.
- CW SIDETONE - Internally generated. Adjustable for level and pitch. Operates only in cw mode.
- SSB GENERATION - 9 MHz, 8 pole crystal lattice filter. Balanced modulator.
- AUTOMATIC LEVEL CONTROL - Amplified, with LED indicator. Adjustable from 200 watts input to approximately 75 watts input with front panel control.
- METER - Indicates SWR on transmit.
- CARRIER SUPPRESSION - 60 dB, minimum.
- SIDEBAND SUPPRESSION - 60 dB, minimum, from single tone output at 1 kHz.

FRONT PANEL CONTROLS

Receiver RESONATE; OFFSET (Pull-off); Two BAND switches; RF gain; AF gain; ALC; ON-OFF POWER switch (Pull-off); ZERO BEAT (Pull-on); MODE switch; Main tuning knob; DRIVE; BLANKER (Pull-on).

REAR APRON CONNECTIONS

ANTENNA; POWER; MIC; AUDIO jack; SIDETONE; REC.ANT.; PTT; KEY; EXT. T/R; AUX 12 VDC; MUTE (Normally open and normally closed); T/R-REC switch; ACCESSORIES socket.

SECTION II  
DETAILED OPERATING INSTRUCTIONS

REAR PANEL CONNECTIONS

POWER SUPPLY

Model 544 requires a supply of 12 to 14 VDC capable of supplying 18 amperes, negative ground. It may be operated with any mobile installation having a 12 volt battery, or powered from an ac supply, such as TEN-TEC Models 252G or 262G.

For optimum mobile performance it is recommended that a separate cable of at least 12 gauge conductors be run directly from the battery to the transceiver.

For fixed station use, cable length from power supply should be as short as possible, and again, made from 12 gauge or larger wire. The chassis should be strapped to a good earth ground system as should all other equipment, both as a personal hazard precaution and for optimum performance.

A power switch is located on the AF control and is wired only to pins 2 and 3 of the four pin POWER socket on the rear apron. This switch is not in series with the input power leads. The switch need not be used for ac operation if on-off switching is desired at the power supply location. Or, the switch may be connected in series with the 115/230 volt primary lead to the supply if switching function is desired from the front panel. In this case the power supply switch should be permanently positioned in the "on" position. TEN-TEC power supplies designed for use with this model already have provisions for this method of switching.

For dc operation, the contact rating of the switch on the AF control is not sufficiently high to carry the 18 amperes required. Switch contact resistance will result in an appreciable voltage drop across the switch. If panel on-off control is desired, use panel switch to control an intermediate 12 volt dc power relay with contacts rated for more than 18 amperes. The Guardian 200 series or Potter-Brumfield PR3DYO relays are types that may be used. Auto parts suppliers are also good sources for relays, but make sure coil rating is for continuous 12 volt use and not intermittent use.

Pin connections for the POWER socket are: Pin 1 = GND; Pins 2 and 3 = ON-OFF switch; Pin 4 = +12-14 VDC. Pin 1 is the keyed terminal.

The +12 volt line is fused with a 20 ampere, fast-blo fuse and a high power diode is connected across the line to ground in a normally reversed-biased polarity. Under these conditions, the diode does not conduct. If, however, reverse polarity voltage is applied, the diode conducts heavily and blows the fuse, thereby protecting transistors and electrolytic capacitors.

GROUND STRAP

To reduce the possibility of stray rf pickup on interconnecting cables, which may cause parasitic problems, all station equipment should be well grounded to earth. It is also important to strap the equipment chassis together with short, heavy leads, preferably shield braid. The strap between power supply and transceiver also serves to reduce voltage drop on the negative 12 volt lead caused by resistance in the connector contacts. In mobile installations, connect a ground strap between the rear panel ground lug and the automobile chassis (dash board).

ANTENNA

Any matched antenna presenting 50 to 75 ohms impedance will load satisfactorily. Random length antennas and open wire feed systems will require a matching system. Most popular mobile antennas will operate without special matching. When they are used as a portable antenna, a good ground system or counterpoise should be provided. Model 544 is designed for use with an unbalanced feed system. Coax shield is connected to the shell and the center conductor to the pin of the PL-259 connector.



## MICROPHONE

The microphone input circuit has been designed for high impedance crystal, ceramic or dynamic microphones. Transistorized microphones may also be used, providing that their output level is set so that the input stage is not over-driven. The cable, which preferably should provide shielding for all leads, is terminated with a standard 1/4" stereo type phone plug. The shield and/or ground lead are connected to the barrel, the PTT switch to the tip and the microphone signal lead to the band. Failure to shield both microphone and PTT leads may result in rf getting into audio circuits.

Since the crystal lattice filter system is common to both receiver and transmitter circuits, any audio signal picked up by the microphone while receiving may be applied to the system and appear in the audio output. Acoustic feedback may occur and cause a sustained howl. To completely eliminate any microphone pickup, it is recommended that a SPDT switch be used for the PTT function in the microphone, and that the microphone signal lead be shorted to ground during receive. The TEN-TEC Model 215P microphone has such an arrangement.

The PTT switch operates with respect to ground. When transmitting, the switch is closed.

## KEY

The key actuates a series of circuits on the CONTROL BOARD assembly that supplies operating voltages to various transmitter and receiver circuits. When the key is closed, bias is removed from receiver stages and applied to the transmitter. The receiver antenna circuit is also grounded during transmit with a reed relay. There is a small time constant in the audio muting circuit to eliminate clicks in the speaker while keying. It is not long enough to interfere with the complete break-in feature. The CW sidetone and key operate only when the MODE switch is in either CW-1 or CW-2. Sidetone volume is independent of the AF volume control. It may be set to the desired level with the printed circuit thumb potentiometer accessible through the hole in the bottom plate. A second potentiometer adjacent to the level control adjusts sidetone pitch over approximately one octave.

For proper transmitter operation, the key line requires a very low resistance path to chassis, with no appreciable voltage across it. Hence, electronic keyers especially designed for low positive voltage transistor switching or those utilizing reed relay switching are recommended. Some transistor switched keyers may not key the transmitter at all in the case of negative voltage circuits, or may present too high a saturation DC residual voltage in positive voltage circuits. Improper key line conditions may cause lower than rated power input, improper keying envelope and/or key clicks.

## AUDIO

The AUDIO jack is provided for an external speaker or for headphones. When in use, the internal speaker is automatically disconnected. The amplifier output is designed for an 8 ohm load but will operate satisfactorily with high impedance phones or speakers with 4 to 16 ohms impedance. Since the amount of power required to drive certain headphones to a satisfactory level is much less than for a speaker, it is recommended that an attenuating network be used between the AUDIO jack and the phones, when using low impedance phones. The attenuator will greatly reduce residual noise and audio feedthrough when transmitting because the audio amplifier will be operating with a more favorable signal to noise setting of the AF control. A simple resistor network consisting of approximately 15 ohms in series with the phones and a shunt resistor of 2.7 or 3.3 ohms across the phones should suffice. The resistors, both 1/2 watt types, can be soldered to the phone plug terminals and concealed in the shell.

## AUX 12 VDC

This jack may be used to power external equipment such as an electronic keyer. It is connected to the + 12 VDC line after the protective fuse. If an AC supply is employed, its current capacity must be great enough to supply the TRITON requirement plus that of any equipment powered through the AUX 12 VDC jack.

MUTE N.O. - N.C.

These jacks are provided to supply a short circuit to ground for muting an external receiver, or for controlling the T/R function of a high power linear amplifier. A set of SPDT relay contacts provides this function, with the common lead connected to chassis. When transmitting, the N.O. (normally open) contacts will close and the N.C. (normally closed) contacts will open. Both options are provided to cover all receiver and linear amplifier designs. A drop-out delay is incorporated in the relay circuit and is adjustable with a thumb potentiometer, R12, located on the OT-TR assembly, 80281. Since this relay does not control any internal functions in the transceiver, delay is factory set to an average value when shipped. It should be adjusted for a suitable delay only when external equipment is controlled by the mute and/or external T/R circuits. (See EXT. T/R paragraph below.)

CAUTION: There are two potentiometers on 80281. It is very important that the setting of R9, final bias adjustment, not be disturbed. Improper setting of the bias potentiometer may result in highly distorted audio transmission or output transistors overheating and possibly failing. Refer to Figure 1, SECTION III, for location of R9 and R12.

EXT T/R

This jack is intended to actuate a high power linear amplifier. It is derived from a second set of normally open contacts on the mute relay. One side of this switch is also at ground potential, and therefore should not be used to switch the 115/230 volt line. The drop-out delay is the same as that described in the MUTE paragraph above, and the caution note in setting delay should be adhered to. Contact ratings are 28 volts @ 2 amperes, DC resistive load, or 100 VAC.

REC. ANT.

This jack provides an antenna connection directly to the receiver input. It can be disconnected from the transmitting circuits by placing the T/R-REC switch in the REC position. In this mode there are no protective devices, either back to back diodes or the shorting relay, across the receiver antenna input.

T/R-REC. SWITCH

This switch, in REC position, connects the receiver antenna terminal to the REC. ANT. jack directly. It is used when an instant-break linear or a separate receiving antenna is used. In the T/R position the receiver input is connected to the ANTENNA socket for normal transceiver operation.

SIDETONE

The output from the audio amplifier is connected to the SIDETONE jack. It may be used to provide a monitor when a separate receiver is employed. Turn the AF control fully CCW to eliminate any signals from the internal receiver from being applied to this jack. This jack may also be used as a phone patch connection to the speaker circuit, or for a headphone jack if it is desired to have the internal speaker remain operable with phones.

PTT

This jack is in parallel with the push-to-talk line on the microphone jack. It may be used as an external transmit/receive station switch and is operable only in the SSB modes.

FUSE

The fuse is a 3AG, fast blo, 20 ampere type which is connected in the + 12 VDC line. Replace with an equivalent type.

## ACCESSORIES

This octal socket allows easy connection of the TEN-TEC Model 240 One-Sixty Meter Converter, Model 241 Crystal Oscillator, Model 242 External VFO, or other accessories to the Model 544. Refer to main block schematic for pin connections. When no accessories are employed, it is necessary that the jumper plug shorting pins 2 and 5, and pins 6, 7 and 8 together be inserted into the ACCESSORIES socket for the transceiver to operate.

## FRONT PANEL CONTROLS

### RF - AF

The RF gain controls the bias to i.f. amplifiers and supply voltage to the rf amplifier. It is used to reduce susceptibility to overload in the presence of extremely strong signals. The AGC is dependent on the setting of the RF control.

The AF control varies input level to the audio power amplifier assembly, and should be used in conjunction with the RF control to minimize AGC pumping. To do this, temporarily set RF control fully clockwise. Adjust AF setting while receiving a strong station, S7 or better, to a level just a bit louder than desired. Then reduce the level of this station, and all other stations, to the desired value with the RF control. In this way only one setting of the AF control need be made. This procedure also eliminates inter-character signal blasting when operating CW with QRM present.

To obtain an accurate S meter reading of an incoming signal, temporarily advance the RF control to full clockwise position.

### POWER ON-OFF

This push-pull switch is located on the AF control and shorts pins 2 and 3 of the four pin POWER connector when pushed in.

### ZERO BEAT

This function is intended for use only in the CW modes. When this knob is pulled out, the carrier oscillator is offset in receive the same 750 Hz that it is in transmit, and the OFFSET control is automatically disabled. When this is done, it is possible to adjust the transmitting frequency exactly to the incoming signal by zero-beating the received signal. After this is accomplished, returning the knob to the "in" position results in the beat note being heard. To zero beat a signal is much easier and accurate than to judge a 750 Hz tone, as is necessary without this feature. Also, by moving the carrier into the passband of the filter, beat notes will be heard on both sides of the center frequency, which again facilitates zero-beating the signal. (When Model 245 CW Filter is used, set MODE switch to CW-2 broad position for best accuracy while zero-beating.)

### MODE SWITCH

The SB-N setting of this switch is used for SSB transmissions on the normal side of the carrier frequency. It will provide lower sideband signals on 80 and 40 meters and upper sideband on 20, 15 and 10 meters. This is accomplished by using either the sum or difference frequencies in the mixer. The opposite or reverse sideband can be selected by rotating the MODE switch to the SB-R position. In the SSB modes, the transmitter can only be energized by shorting the PTT line to chassis. The CW key line is disconnected.

Two CW positions are indexed on the MODE switch, CW-1 and CW-2. Model 544 as shipped from the factory will receive signals in the CW mode only in the CW-2 position. The transmitter will function in both positions, however. As shipped, the bandwidth in the CW-2 position is identical with that in the SSB modes. When the Model 245 CW Filter accessory is installed, the CW-2 position then provides a bandpass curve peaked at 750 Hz with reduced response on either side. In the CW-1 position, the full 150 Hz wide filter is connected into the circuit, which provides very sharply attenuated skirts. CW-2 should be used when QRM is not a factor, when tuning to a desired signal or when the signals on either side of the centered signal are to be monitored. CW-1 will greatly attenuate signals slightly

removed in frequency from 750 Hz, eliminating adjacent channel QRM, and will also reduce the amount of QRN and annoying high frequency audio signals. In mobile operation, it will be found that the CW-2 position can be used for SSB reception with reduced high frequency ignition noise components.

In the CW positions, sidetone signal is fed to the audio system. Its level and pitch can be adjusted with the two adjacent thumb potentiometers accessible through the large hole in the bottom plate.

In CW, the transmitted frequency is automatically offset 750 Hz from the receiver setting. This compensates for the 750 Hz beat note of the received signal and puts the transmitter exactly on the received frequency. 750 Hz was selected as the offset to correlate with the center frequency of the Model 245 CW Filter. When the received signal is peaked on the S-Meter, the beat note will be 750 Hz.

The transmitter can be switched on only by shorting the KEY jack to chassis in the CW modes. PTT lines in the MIC jack and the external PTT jack are disconnected.

The LOCK position of the MODE switch is used for system checks and SWR measurements. It energizes the transmitter on the CW frequency but does not key the sidetone oscillator.

#### ALC CONTROL

This control sets the threshold level at which automatic level control starts. When fully clockwise, input power is factory adjusted for 200 watts on the least efficient band when the ALC indicator just starts to light. Input power can be reduced below this level to approximately 75 watts when control is fully counterclockwise. A change in the ALC control setting requires a readjustment of the DRIVE setting.

The control enables the user to set the output power below its maximum, while still retaining ALC control, in cases such as when driving high power linears that do not require the full output capabilities of the transmitter, where antenna SWR is so high that power supply demands are exceeded, or where reliable communications can be attained at reduced power levels.

#### DRIVE

Both microphone gain and CW level are adjusted with the DRIVE control. For SSB, advance the control under normal speech operation until ALC indicator lights on voice peaks. For CW, advance the control until ALC indicator lights on key-down. The setting should be the same whether dits, dahs, or a continuous signal are used. For CW, the drive setting can be made in the LOCK position also. But this setting does not hold for SSB since microphone type, closeness to lips and loudness of speech all determine the DRIVE setting.

#### BAND SWITCHES

The main switch selects amateur bands of 3.5, 7.0, 14.0, 21.0 or 28.0 to 30.0 MHz. A second switch selects the 10 meter segment desired. The Model 544 is supplied with all crystals except those covering 29.0 to 30.0 MHz.

#### MAIN TUNING

Megahertz, kilohertz and hundreds of hertz are displayed on the six digit LED display. Hundreds of hertz is in green to easily separate the fraction of a kHz from the rest of the reading. When using Model 242 Remote VFO, the display will read the frequency in use at the time. The counter can be accurately set to WWV as outlined in Section III.

The main tuning knob skirt has 1 kHz markings to facilitate quick, relatively small frequency excursions, such as is used when QSYing to avoid QRM, or when passing traffic in net operation. (Up or down 5 or 10 kHz is easily accomplished without having to read the digital display.)

Since the VFO shaft is raised from chassis potential to eliminate frequency jumping caused by poor sliding contacts, there is a very small hand capacity effect on frequency when either dial skirt or knob insert are touched. To eliminate this effect, grasp only the plastic portion of the main tuning knob, or use the finger spinner when fine tuning the VFO.

### RESONATE

The RESONATE control operates a mechanical assembly that permeability tunes the receiver rf amplifier circuits. Peak this control on the received signal. It has no effect on any of the transmitter circuits. The band notations around the knob are only general indications of correct positions. The correct peak will be found to move substantially from one end of the 80 meter band to the other and to a lesser degree on the other bands. It is possible to peak the control on the image frequency or the internal 9 MHz oscillator on all but the 3.5 MHz band, and care should be taken to see that the correct peak is tuned. For instance, the 9 MHz oscillator can be peaked on the 7.0 MHz band clockwise from the desired 7 MHz, and on the 14 MHz band counterclockwise from the desired position. Also, the image on the 21 MHz band occurring at approximately 15 MHz can be found counterclockwise from the desired 21 MHz peak. (It is this peak that is used when receiving WWV at 15 MHz.) And on the 28 MHz band, the 10 to 12 MHz image is heard fully counterclockwise, although it is not fully peaked. (WWV at 10 MHz may sometimes be heard using this image.)

### OFFSET TUNING

The OFFSET control tunes the receiver independently of the transmitter by approximately  $\pm 5$  kHz. A push-pull switch attached to the control shaft disables this circuit when pulled out. Clockwise rotation from the center zero position increases the received frequency and counterclockwise rotation decreases frequency.

Offset is advantageous when several stations are being worked in a round-table and all are not exactly on the same frequency. The received stations can then be zeroed in with the OFFSET control without upsetting the frequency of the transmitter. Also, it is very useful in working DX where the DX station is working stations slightly off his frequency.

The indicator on the front panel, marked OT, lights when the offset circuits are switched on. (You will notice that the indicator will go off when transmitting.)

### GENERAL OPERATING NOTES

#### WWV

Broadcasts of WWV and WWVH may be received on 10 and 15 MHz for purposes of checking the accuracy of the counter time base oscillator or for propagation reports and time determination. To receive the 15 MHz signal:

1. Set BAND switch to 21.0 MHz.
2. Rotate main tuning dial so that frequency readout is 21.000 MHz.
3. Tune the RESONATE control to the image frequency located almost fully CCW (between the 3.5 and 7.0 markings).
4. If WWV is not heard, tune around this frequency a bit until it is received, providing that the band is open. If you have a choice of antennas, it may be that one will pick up 15 MHz better than another, and not necessarily the 21 MHz antenna.
5. Zero beat the WWV signal. The digital readout should read 21.0000. If it does not, the time base oscillator requires readjustment. (Subsection III)

To receive the 10 MHz WWV signal, use same procedure, but tune to the image on the 28.0 MHz band. Frequency readout will be 28.0000 at the point of WWV

reception. Since 10 MHz cannot be fully peaked with the RESONATE control, it requires that this control be set fully CCW and that a stronger signal be present at the antenna terminals than the 15 MHz signal.

#### MOBILE OPERATION

Model 544 is ideally suited for mobile operation in a car, boat, plane or other vehicle. It operates directly from a 12-14 volt battery source and is self-contained except for key, microphone and antenna. The SWR meter is especially useful in setting mobile whip antenna lengths to the operating frequency.

When using an alternator charged battery, start and stop the vehicle's engine with the transceiver turned off. This prevents any high voltage transient surge from momentarily open regulator contacts being applied to the transceiver circuits.

#### FIXED STATION

Model 544 with conventional antennas will perform with distinction in any ham shack. With a linear, power can be increased to any value desired--up to the legal limit. For an emergency or stand-by station it will operate for long periods of time with a 12 volt automobile storage battery. Increased battery operating time can be achieved by setting the ALC control down from its maximum position.

#### PORTABLE

The unit's small size and light weight make it an ideal traveling companion. Antennas are a matter of choice and convenience. A mobile whip may be used with a suitable ground system (radials) or a good earth ground. Matched resonant dipoles are fine if there is a support for them. Random length "long wires" are also effective but must be matched with an antenna tuner. In any event, try to maintain a 3 to 1 or better SWR.

#### FULL TEN METER COVERAGE

Model 544 as shipped from the factory has crystals installed which permit operation between 28.0 and 29.0 MHz. Two additional crystals are available as accessories which extend coverage to 30.0 MHz. Model 212 Crystal provides coverage in the 29.0 to 29.5 MHz segment and Model 213 in the 29.5 to 30.0 segment.

To install either or both of these crystals, remove the screws holding the bottom plate to the side and back panels, as well as the two located near the center. The speaker grill and two snap-up legs need not be removed for crystal installation. Slide plate back several inches and locate the small dual crystal socket adjacent to the two wired in crystals. (Refer to Figure II, Section III.) To correlate band switch designations with correct frequencies, insert Model 212 into socket nearest the wired in crystals and Model 213 into socket farthest to the right. Crystals are marked with operating frequencies and TEN-TEC part numbers as follows:

<u>Model</u>	<u>Operating Frequency</u>	<u>Coverage</u>	<u>Part No.</u>
212	14.990 MHz	29.0 to 29.5	48009
213	15.490 MHz	29.5 to 30.0	48010

#### OPERATING HINTS

1. The speaker is most effective when the unit is placed on a hard surface and the two front snap-up legs are extended. With legs down, adequate sound quality is still produced when the unit rests on a hard surface. However, in mobile operation for example, where the speaker may be muffled by the seat cushion or floor rug, an external speaker may be necessary.

2. When setting up the station, provide adequate ventilation for the heat sinks on the transceiver and power supply. Do not confine units to a small volume without forced ventilation to circulate cool air around the heat sinks.
3. When operating RTTY, SSTV or other high duty-cycle modes, it is recommended that a small fan be directed on the heat sink. The sink temperature may reach as high as 200° F, still within the rating for the transistors but certainly hot enough to cause a serious burn if touched.
4. Operation as a QRPP transceiver simply requires adjusting DRIVE control downward. To determine input power, insert a DC ammeter in the + 12 volt line (Model 207 Ammeter for TEN-TEC Power Supplies). For every ampere increase over the no-drive quiescent level in the LOCK mode, the power input to the final is increased by about 13 watts. For example, assuming that the quiescent current is 2 amperes, a 4 ampere reading on the ammeter indicates 26 watts input.
5. The S-Meter will be accurate only when RF control is fully clockwise. The meter is factory calibrated for a 50 uV reading of S9 on the 14 MHz band.
6. To determine SWR, set MODE switch to LOCK position, ALC control fully clockwise and advance DRIVE control until ALC indicator lights. Read SWR on lower scale.
7. Sidetone level and pitch controls are accessible through finger hole located in bottom plate.
8. In SB-R mode, dial calibration will be off approximately 3.0 kHz from the SB-N setting. On the 3.5 and 7 MHz bands the indicated frequency will be higher than the actual value and on 14, 21 and 28 MHz bands, it will be lower.
9. In CW modes, the indicated frequency is the received frequency. To accurately read an incoming frequency, therefore, it is necessary to zero beat the signal, not peak it on the S meter. This holds true no matter where the OFFSET control is set. When transmitting CW, the indicated frequency will be 750 Hz removed from the true transmitted frequency, due to the BFO shift to bring the oscillator into the filter pass band. This shift will be in the same direction as the shift when working the SB-R mode, i.e. the indicated frequency will be higher than the transmitted frequency for frequencies below 7.5 MHz and lower for frequencies of 14 MHz and above. Due to the 750 Hz switch in frequency every time the key is actuated in the TRITON instant break-in system, an accurate transmitted frequency count cannot be made while sending code. To accurately determine the transmitted CW frequency, make the reading in LOCK or key-down condition and either add or subtract 750 Hz from the reading, depending on the band in use. (Example: To set up a transmitting frequency of 3.545 0 MHz, place MODE switch in LOCK mode and adjust tuning for reading of 3.545 7 MHz. For 14.062 0 MHz, set readout to 14.061 3.)
10. Increasing DRIVE setting over that required to just light ALC indicator will not result in any appreciable increase in power out. However, overdrive may increase SSB distortion products and destroy CW keying characteristics.
11. To minimize AGC pumping when receiving strong signals and eliminate loud bursts between transmitted CW characters, reduce setting of RF control so that S-Meter reads approximately half scale.
12. The VFO oscillator, like any LC tuned oscillator, is adversely affected by ac magnetic fields cutting the coil turns. The oscillator output is frequency modulated at the line frequency, causing a "dirty"

CW note and/or poor SSB quality in both transmit and receive modes. When installing, locate any ac operated equipment which may generate magnetic fields, such as power supplies, electric clocks, keyers, rotator controls and other station accessories, as far as possible from it. Since the VFO is located front and center, the most common cause of FMing is from placing these accessories on top of the unit. However, large power supplies may cause interference even when placed adjacent to the transceiver. A check of the purity of a received CW signal should be made at the time of installation.

13. Due to the possibility of high voltage transients being generated in the output rf amplifier during band switching, changing bands should not be done while transmitting power to the load. Either place the transceiver in the receive mode or be certain of a "key-up" condition in CW. YOU RISK THE POSSIBILITY OF DESTROYING THE OUTPUT TRANSISTORS IF THIS PRECAUTION IS NOT OBSERVED.
14. Although improper antennas will not damage the output transistors, we suggest an SWR below 3 to 1 be achieved for maximum performance. In cases where the antenna cannot be matched to a better SWR, and the TEN-TEC power supply repeatedly shuts down due to over-current conditions, the transceiver can be operated at reduced input power by rotating the ALC control counterclockwise to a position where the supply does not trip out.

#### AN IMPORTANT MESSAGE

In order for you to attain top performance from your transceiver, we feel that you should be briefed on all new information that comes to us from the field regarding the installation and operation of these units. Also, especially in the case of new technology such as solid state no-tune rf amplifiers, misconceptions sometimes arise from incomplete knowledge which result in erroneous conclusions being drawn that the equipment is faulty, erratic or not performing to specifications. There is a sufficient number of units now in the field to indicate to us that there are several rather serious information gaps in these areas. It is the purpose of this message to fill in these gaps so that you can knowledgeably approach and correct any apparently improper performance characteristics of the transceiver and power supply.

The main field concern appears to be a matter of fundamental technical knowledge regarding SWR, efficiency and protective circuitry such as ALC and power supply overload protection.

Before presenting a detailed explanation regarding this information gap, a summary of ten points to be aware of at the time of installation is given below. The reasons and technical background for these observations are explained thoroughly in the paragraphs below.



### Ten Points to Observe When Installing Model 544

1. The transmitter will give best performance when properly loaded.
2. Even though the output transistors are resistant to damage from improper loads, they will not operate satisfactorily under all load conditions.
3. The output transistor dissipation will increase if not properly loaded.
4. Reactive impedance components in the antenna are applied to the transistors and may cause parasitic oscillations.
5. A given SWR reading does not tell you anything about the reactive components and is not accurate unless the load is a pure resistance.
6. A given SWR indicates one of two possible impedances. Each acts differently on the transceiver performance.
7. The most efficient operating point is when the load is 50-75 ohms, resistive.
8. The ALC light is not an indication of the input power, but the output power. It may not light even though the power supply is delivering enough current to trip the breaker.
9. If the breaker repeatedly trips, it is an indication that the load is enough removed from optimum so as to cause high transistor dissipation.
10. It is possible for the power supply regulator to drop out of regulation just prior to its tripping the breaker. Under these conditions, hum modulation will appear on the transmitted signal. With proper load, current drain will be considerably below the tripping point, so no hum should appear.

### Technical Facts of Life

Although vacuum tubes and transistors both can be made to amplify rf power, there are some fundamental differences in how this is accomplished. We are all familiar with vacuum tube principles, but not with those of transistors. A better understanding of what we can expect under various operating conditions will aid in recognizing correct or incorrect performance.

1. Broadband vs Resonant Tanks - Almost all tube circuits use resonant tanks in the plate circuit. Model 544 uses a broadband system. In class AB operation these two approaches act similarly without drive being applied. The idle current is relatively low and within the device dissipation rating, even with load impedance variations from open to short circuit.

However, with drive applied, the two act very differently. In the case of tubes, the dissipation within the tube depends on both the tuning of the tank and the load applied. If the tank is resonated, and the load is very light, the internal power dissipated is quite small, as indicated by the null which reduces plate current almost to the level with no drive. Out of resonance, the plate current and hence dissipation increases rapidly and may damage the tube from overheating. In resonance, as the load is increased, the null becomes more shallow at a higher plate current, as a result of the power being delivered to the load. As the tank is tuned to resonance, the load impedance, which is usually on the order of 50 ohms, is transformed to a relatively high impedance of several thousand ohms to match the plate circuit impedance. Small load reactive

components--either capacitive or inductive--can usually be balanced out in the tank resonating function.

With transistors, drive applied and no load, there is no resonant high impedance to limit the collector current, and so power is poured into the circuit (much as the out-of-resonance tank condition). Since there is no load power, all has to be dissipated in the transistor. So even with no load, the power supply circuit breaker may trip. The broad-band transformer system used with transistors transforms the 50 ohm load impedance not higher, but much lower (in the order of 4 or 5 ohms) to match the transistor output impedance. Since this transformation is fixed in design, any reactive component in the load impedance is applied in a transformed way to the collector circuit. Certain reactances at this point, especially inductive, give rise to parasitic oscillation. To correct for this, the antenna impedance should be changed to remove this reactance, or a matching network should be inserted between antenna and transceiver. It is important to remember that any antenna changes its impedance with frequency, so one that resonates well at one end of the band may well cause oscillations or trip the circuit breaker on the other end. If entire band operation is desired, especially on 80 and 40 meters, the adjustable matching network approach would be the better choice, rather than try to make the antenna behave over the entire band on a cut-and-try basis.

A final point to bring out regarding broadband vs tank systems is that there is a limit to the amount of current you can draw from an emitting filament and this saturation current will limit the amount of power drawn from the supply. In the case of transistors, where the collector internal impedance is only a fraction of an ohm, extremely high currents can be demanded of the power supply, especially with mismatched loads well below 50 ohms. A fuse is provided in the DC supply line for protection when operating from a power source that is not limited, and our power supplies have current limiting circuits.

2. SWR - Two Kinds - The standing wave ratio is a direct measure of the ratio between two impedances, i.e. an SWR of 3 to 1 tells us that one impedance is three times the other. Therefore, the unknown impedance can be either three times as large or three times as small as the known one. If the desired impedance that the transceiver wants to see is 50 ohms, a SWR of 3 to 1 on the line may mean a load impedance of either 150 ohms or one of 17 ohms. If it is 150 ohms, the transmitter will act differently than if it is 17. In the first case, the power demanded from the supply will be much lower, and will not be large enough to trip the supply. In the second case, even though the SWR meter reads the same, the supply may repeatedly trip out. The SWR reading gives no indication of reactive components, nor can it separate the resistive from the reactive components. It is calibrated with a pure resistive load and therefore has its greatest accuracy with pure resistive loads. The SWR bridge only should be used as an indicator when attempting to adjust the antenna system to a pure 50 ohm resistive impedance.
3. Efficiency - Since transistor amplifiers have a very low value of output impedance, they act more or less as a constant voltage source. That is, the rf output voltage tends to remain at a fixed value regardless of the load impedance. Hence, the output power will vary depending on the value of load and increase as the load impedance goes down. It can be seen that a 3 to 1 SWR on the low side of 50 ohms will ask the amplifier to deliver much more power than a 3 to 1 SWR on the high side. Since the amplifier does have a finite value of output impedance, the amount of power delivered to the load with efficiency will change with the load. Unless the load is near the design value, the transistors will heat up unnecessarily without delivering any more power to the antenna.
4. Protective Circuitry and ALC - ALC serves three major functions. It assures the maximum power from the transmitter without careful adjustment of the input drive, it prevents the amplifier from being overdriven

into the non-linear, distortion-producing, operating area and it serves as a power limiting device which protects the output transistors. It does the first two very well, but the third only partially. To absolutely protect the system, we add the current limiting circuitry to the power supply.

The ALC system senses the power output and adjusts drive accordingly. Note that it does not sense power into the final. Therefore, some load conditions may exist where the ALC system will not limit the transistor dissipation. One instance is where there is a highly reactive load. It is not possible to make a reactive load absorb power, so the ALC light will not go on, even though high power is being supplied to the final in the way of internal dissipation. Under these conditions the power supply protective circuits take over and trip the breaker. So it is very possible that the breaker will repeatedly trip without the ALC light going on. If this occurs, it indicates a change in the antenna system or matching network is needed.

A final comment regarding this situation--when the breaker in the power supply trips, the amount of current drawn from the supply may be high enough to cause the supply to drop out of regulation... especially with low line voltages. Under these conditions the output may become hum modulated. The output light on the power supply will also start to dim a bit. This condition should be rectified by antenna and/or matching changes since the emitted quality of the signal will be poor. (Whereas the breaker will trip in the LOCK position, it probably will not with CW or SSB, even though the regulator drops out and produces poor quality signals.)

If the above precautions are observed, we are sure that you will be more than delighted with the performance of your Model 544.

#### Recommended Reading

1. ARRL Antenna Handbook
2. Antenna Handbook, Ken Glanzer, Cowan Publishing Co.
3. W8NWU Teeter Totter Tuners, Schultz, CQ Feb. '69. Page 27

SECTION III  
ALIGNMENT AND SERVICE

This section is subdivided into descriptions of the main chassis and each plug-in assembly. Pin and transistor voltages are given for each unit. Readings should be within 15% of listed values when measured with a dc voltmeter with at least a 20,000 ohms-per-volt impedance. All readings are dc and positive with respect to chassis GND unless stated otherwise. Plug-in pin locations are in the same relative positions on the assemblies as noted on the schematics. In other words, if the assembly is placed component side up on the schematic in the same position as shown in the photograph, the individual pin functions are the same as those noted on the schematic.

When removing a plug-in assembly, note the orientation of the board in the chassis so that it can be replaced correctly. Most assemblies can be inadvertently inserted incorrectly if care is not taken. Figures 1 and 2 show correct placements.

To remove a plug-in, first remove screws holding the assembly to the sockets and any screws or nuts securing single socket boards. Then, with long nose pliers, work the assembly straight up out of the socket or sockets by pulling on the end pins in sequence.

To facilitate location of the various components that may require alignment or adjustment, refer to the table below.

<u>Function</u>	<u>Assembly</u>
Receiver rf Amplifier	Main Chassis, 80166
Receiver 9 MHz Trap	Main Chassis, 80166
Receiver Mixer	TX-RX Mixer, 80287
Receiver i.f. Amp.	I.F.-AGC, 80279
S-Meter Adjust	I.F.-AGC, 80279
Counter Calibration	Timebase-Preamp, 80346
Offset Zero Adjust	Control Board, 80280
USB and LSB Carrier Adj.	SSB Generator, 80282
CW Transmit Offset	SSB Generator, 80282
Carrier Balance	SSB Generator, 80282
Sidetone Level	Audio Pwr. Board, 80274
Sidetone Pitch	Audio Pwr. Board, 80274
Transmitter Mixer Null	TX-RX Mixer, 80287
ALC Level	SWR-ALC, 80284
SWR Null	SWR-ALC, 80284
Reverse SWR Set	SWR-ALC, 80284
External T/R Relay Delay	OT-TR, 80281
Final Amp. Bias Set	OT-TR, 80281
Driver Bias Set	Final Amp. 80276

Note: All VFO linearity, band edge calibration and crystal mixer adjustments are contained in the VFO sub-chassis which is an integral part of the main chassis. This section is described as a separate assembly for simplicity.

DISASSEMBLY

REMOVAL OF TOP

Remove the two screws at the rear of the top. Slide top back and out of grooves in the side panels.

REMOVAL OF BOTTOM

Remove four screws holding the speaker grille. Feed speaker down through cutout, using notches in cutout to clear outer edge of speaker. Remove remaining twelve screws and both snap-up legs. Slide bottom back and out of side panel grooves. When replacing screws, note that sheet metal screws should be used in plastic sides, for snap-up legs and for speaker bezel...machine screws elsewhere.

### DIAL SKIRT REMOVAL AND REPLACEMENT

The main tuning dial skirt is friction mounted to the shaft and can be easily removed by pulling it straight off the shaft after the plastic knob is removed. The felt washers between knob and skirt provide a slight amount of friction to eliminate any backlash between the two.

To replace the dial skirt, either a specially constructed tool as shown below, or a screwdriver with a blade width of approximately  $9/32$ " can be used. With the tool, spread the "D" spring on the skirt hub so that the straight portion does not show through in the hub bore. If the tool tip shows in the bore, this is OK for now. Start the skirt on the shaft, with the tool handle pointing downward in relation to the front panel. This puts the handle of the tool out in the open. Push the skirt on the shaft until the tip of the tool in the hub bore hits the brass portion of the two diameter shaft. While maintaining inward pressure on the skirt, slowly remove the tool from the groove by using a rotational motion on the handle. As the tip is pulled from the hub bore, it will allow the skirt to be pushed on the shaft before the spring can regain its unstressed condition. Seat the skirt as far as it will go.

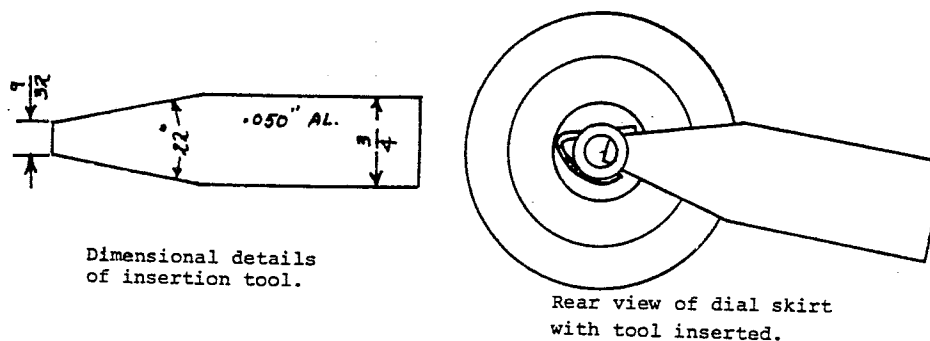

### REMOVAL OF FRONT PANEL

First remove top. Then remove two inside screws holding chassis to side panels. These are located near the top of the unit, one on each side. Remove BAND switch knob with aid of a small flat-bladed screwdriver. Then remove main tuning knob, dial skirt and RESONATE knob using 4-40 Allen wrench provided. The remaining small knobs pull straight off. It may be necessary to pry them off with a flat-bladed screwdriver. Protect front panel from scratches with cloth or piece of cardboard under the driver. Turn unit over and remove two screws in the bottom lip of front panel. Slightly spread the two side panels and remove front panel from grooves. Unplug cable going to PC board mounted on front panel and then separate panel from the chassis.

### PILOT LAMP REPLACEMENT

Model 544 has one miniature 6 volt, 50 mA lamp located in the dial bezel that edge lights the scale. To replace, remove front panel as described above. Then remove bezel by removing small screws holding it to panel. The leads going to the bulb to be replaced should be unsoldered from the PC board and the bulb slipped out of the assembly. Replace with similar type bulb, available from TEN-TEC for 50¢ each.

Meter lamp is a standard 14 volt bayonet type, No. 1813 or 1892. Access to this bulb is by removing top of unit.

### FUSE REPLACEMENT

The fuse located on back panel protects the unit from heavy overload and reverse polarity conditions. Replace with a 3 AG fast-blo 20 ampere type.

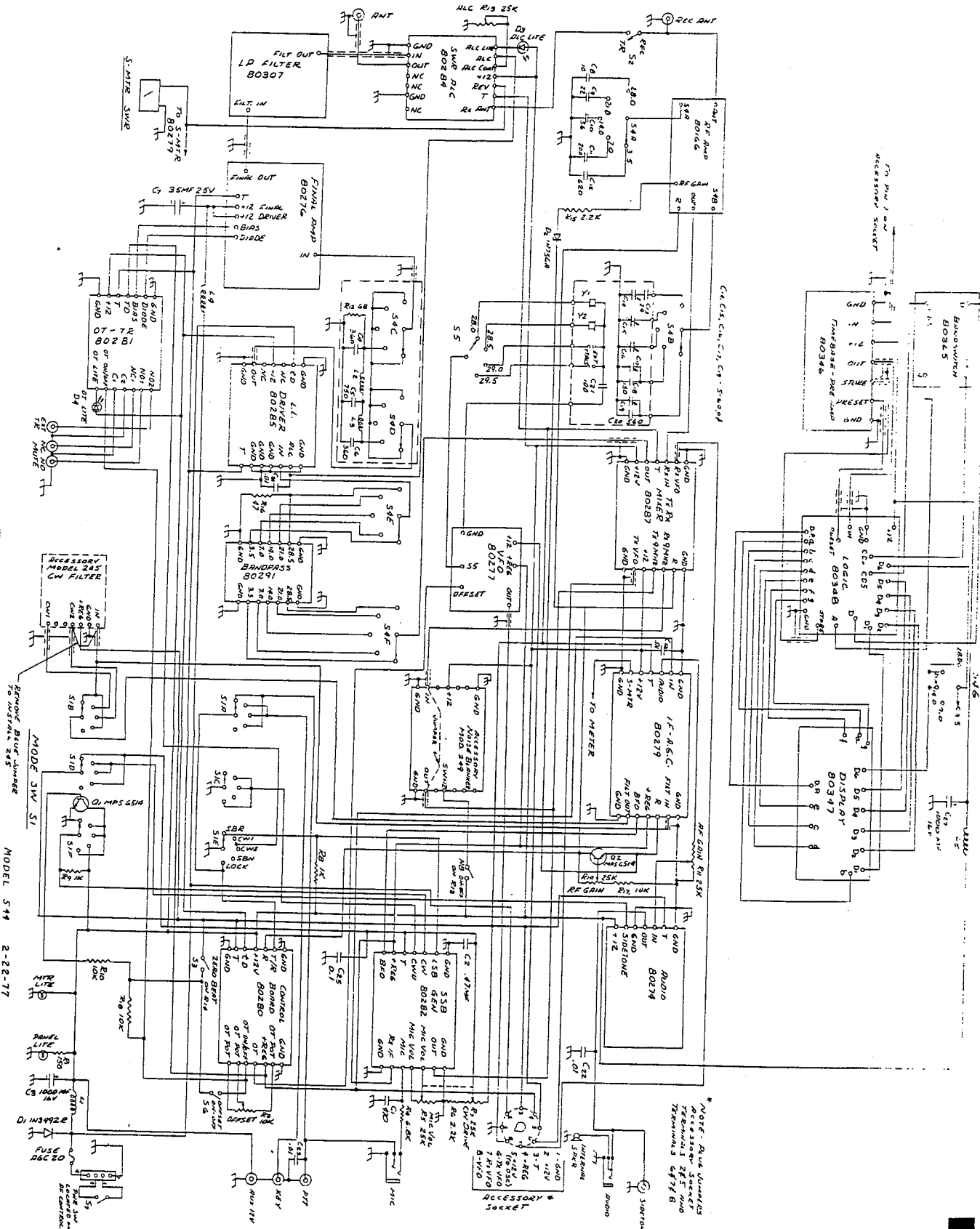

MODEL 549 2-22-77

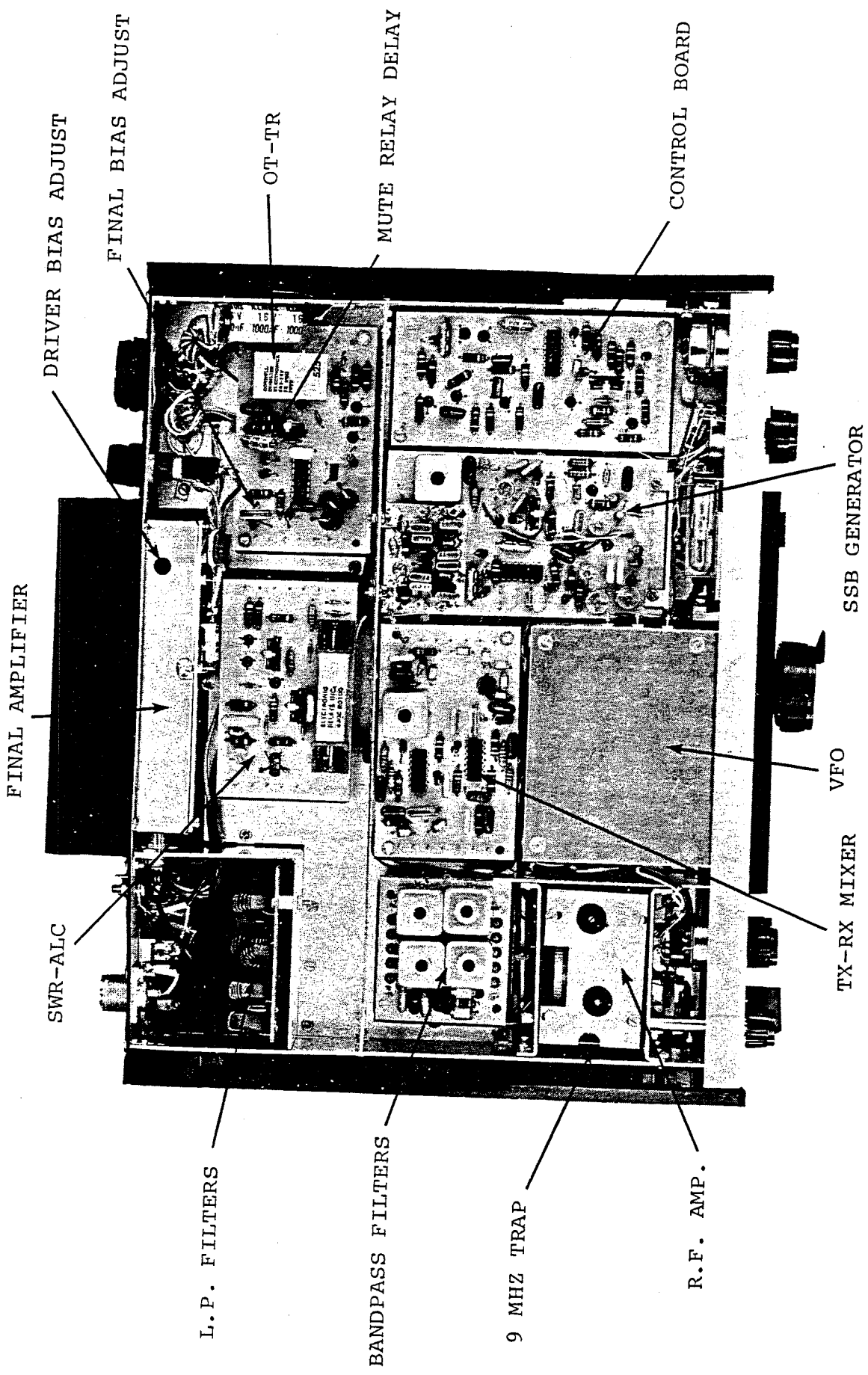

FIGURE 1 - TOP VIEW

7-0044

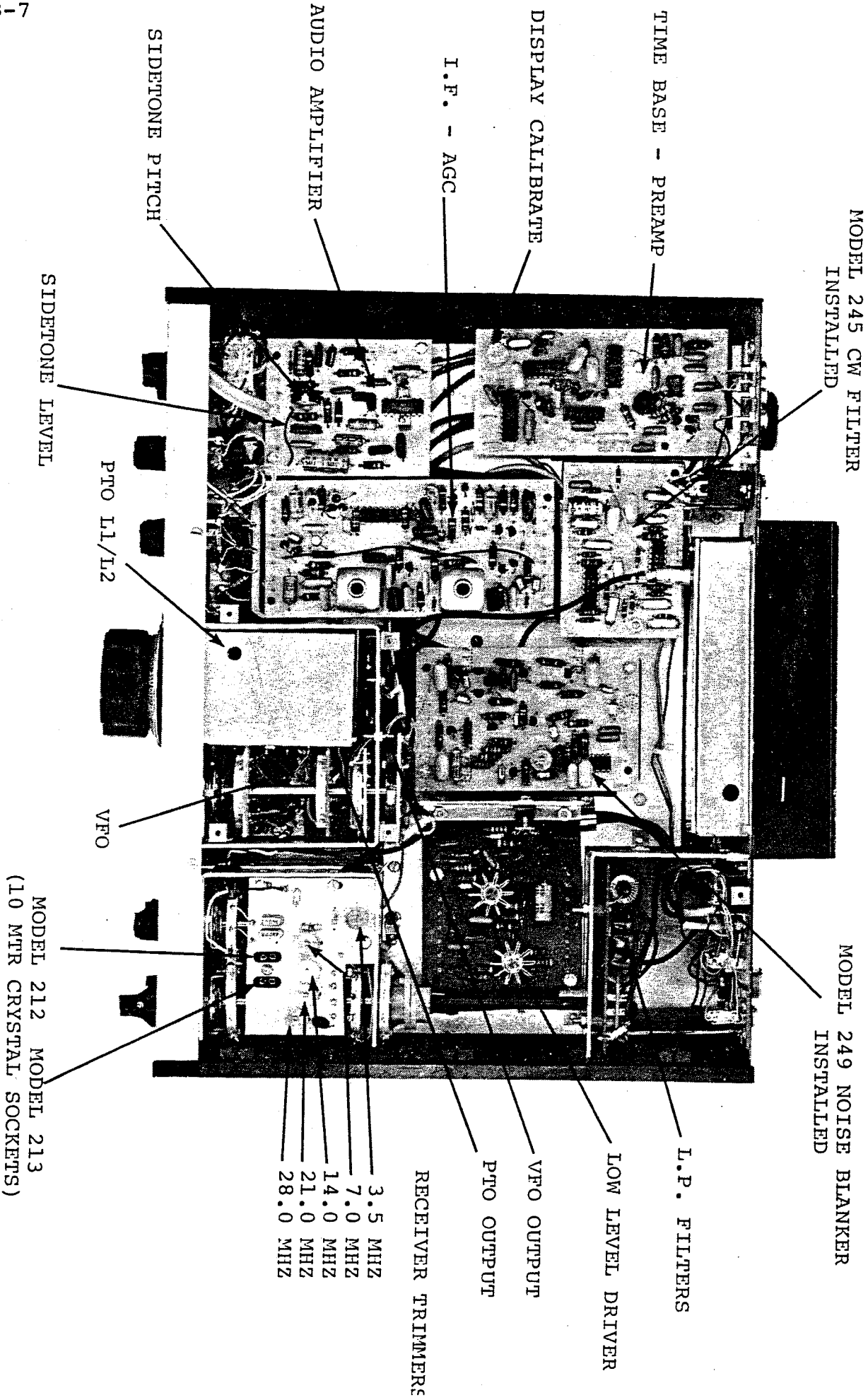

FIGURE 2 - BOTTOM VIEW



## 80166 R.F. AMPLIFIER

The rf amplifier in the receiving section is located on the RESONATE subchassis which contains the permeability tuned rack mechanism. It is a part of the main chassis. The amplifier is a single stage, dual gate MOSFET, Q1, with tuned antenna coil, L1, and output coil, L2. These inductances are slug tuned and ganged by means of the rack assembly. Corresponding capacitors for the tuned circuits are not included on the PC board, with the exception of C3, the 28.0 MHz antenna capacitor. A set of five fixed capacitors are switched across L1 and a set of five adjustable trimmer capacitors, located on a separate PC board beneath the amplifier board, are switched across L2. The antenna input lead contains a 9 MHz trap to decrease direct i-f frequency signals.

The stage is powered through the R terminal, and gain is varied by controlling the G2 voltage of Q1, (RF GAIN terminal) via the RF control.

To align the tuned circuits, proceed as follows:

1. Connect a Ballantine or other suitable ac meter to receiver audio output.
2. Connect signal generator to antenna terminal and position T/R-REC switch in T/R position. Set bandswitch and generator frequency to 3.5 MHz.
3. Temporarily connect a .01 mF capacitor from the 3.5 MHz trimmer terminal pin, located on small trimmer PC board, to chassis. See Figure 2. Set generator level to several hundred uV and tune to receive the signal. Adjust RESONATE control for a peak on the ac meter, keeping signal level sufficiently low so that S-Meter does not register.
4. Disconnect .01 capacitor, turn generator level to approximately 1 uV and peak 3.5 MHz trimmer capacitor.
5. Set frequency to 4.0 MHz, reconnect .01 mF to same terminal and chassis, and increase generator level until signal is heard at 4.0 MHz. Readjust RESONATE control for peak output. Disconnect .01 capacitor, turn down level to approximately 1 uV and peak L2 for maximum output. See Figure 1.
6. Repeat steps 4 and 5 until there is no increase in output. This procedure aligns the 3.5 MHz band and tracks L2 to L1. (L1 should not need any change from factory setting.)
7. Switch to 7.0 MHz and set frequency to mid-band. Connect the .01 capacitor to 7.0 MHz trimmer terminal and chassis. Using the same procedure, as in steps 3 and 4 above, adjust 7.0 MHz trimmer. (No further adjustment of L2 is necessary.)
8. Using same procedure as in step 7, align 14.200, 21.200 and 29.000 MHz.

#### 9 MHz TRAP ADJUSTMENT

1. Set receiver to 7.0 MHz and RESONATE control for maximum output.
2. Without changing settings, adjust signal generator to 9 MHz and increase output until a signal is heard. Tune trimmer capacitor, C7, for null. Refer to Figure 1 for trimmer location. It is mounted on top of the PC board and accessible through the half-round cutout in rack plate. Use insulated tuning wand. Null is very sharp.

Transistor Voltages - (RF Control fully clockwise, rack plate removed.)

Q1 MOSFET

Pin	Transmit	Receive
1-Drain	.05	11.4
2-Gate 2	0	3.9
3-Gate 1	0	1.1
4-Source	0	1.6

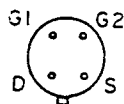

Transistor pins viewed from top of board.

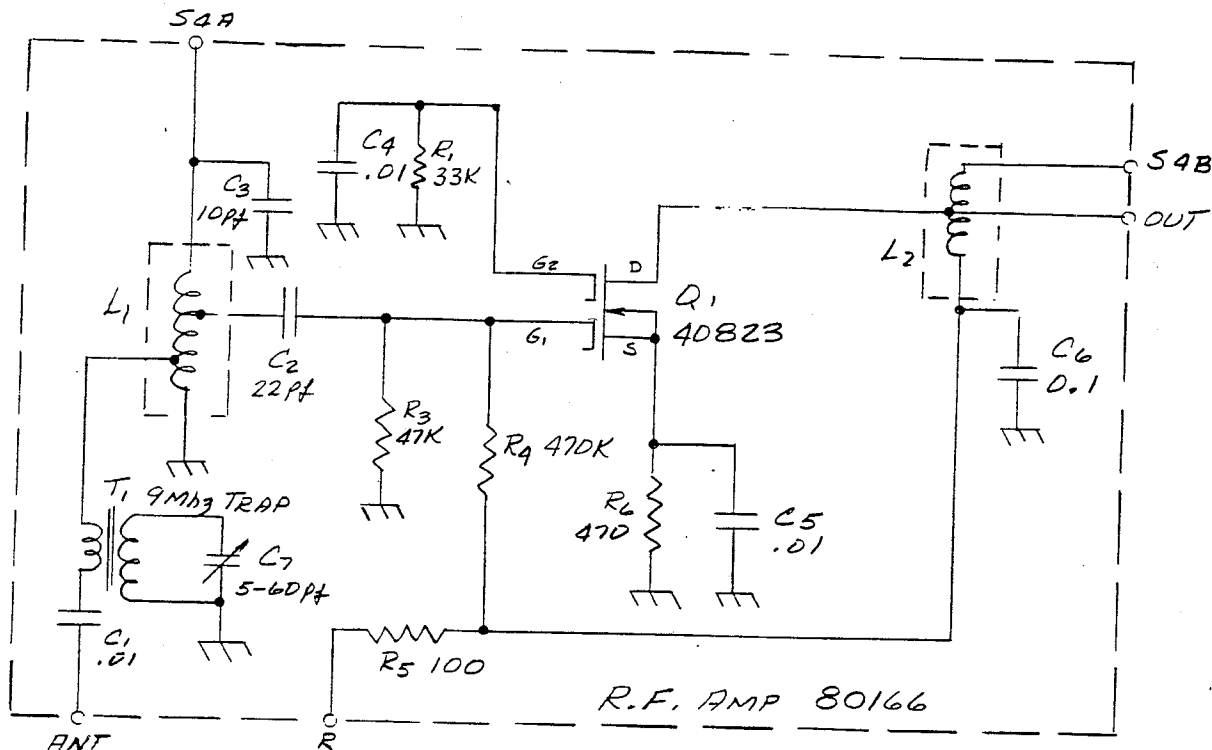

R.F. AMP 80166

9 MHZ TRAP  
C7

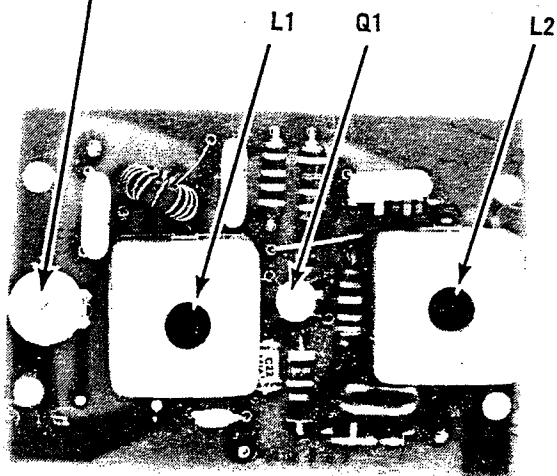

80166 R.F. AMPLIFIER

TRIMMER TERMINAL PINS  
3.5 7.0 14.0 21.0 28.0

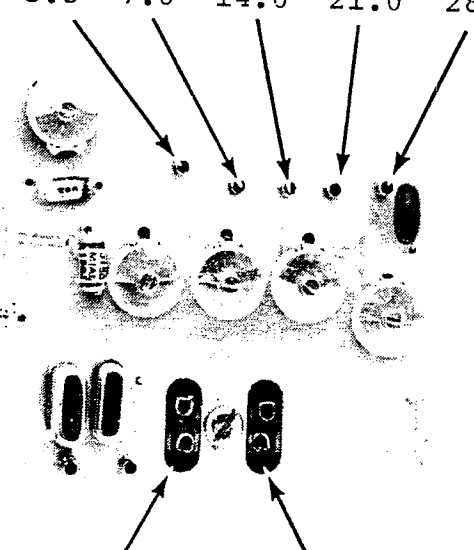

Model 212 Model 213  
TEN METER CRYSTAL SOCKETS

## 80350 VFO

The variable frequency oscillator produces proper injection frequencies for the transmitter and receiver circuits, using a 9 MHz i-f system. This is accomplished by utilizing a permeability tuned master oscillator for all bands, operating between 5.0 and 5.5 MHz, whose output is mixed in an IC double balanced mixer with signals from a crystal oscillator. Crystal frequencies are selected by the BAND switches. The 14 MHz band uses the 5.0 to 5.5 MHz directly.

Output from the mixer is filtered for each band with double tuned resonant circuits and then sent to a darlington follower stage. Frequencies for the various bands are as follows:

<u>BAND (MHz)</u>	<u>VFO OUTPUT (MHz)</u>
3.5	12.5-13.0
7.0	16.0-16.5
14.0	5.0-5.5
21.0	12.0-12.5
28.0	19.0-19.5
28.5	19.5-20.0
29.0	20.0-20.5
29.5	20.5-21.0

The permeability tuned oscillator (PTO) is housed in the main tuning coil housing on a separate, sealed PC board. It is noted on the schematic as sub-assembly 80278. The main coil, L3, is shunted with L2 and has L1 in series. Adjustment of these two slug tuned coils, which are both on the same coil form, determines the linearity and band edges. L2 is the coil nearest the aluminum cover when viewing the VFO assembly from the bottom.

SETTING PTO BAND EDGES

Coils L1 and L2 in the PTO assembly are adjusted at the factory for a total frequency excursion of about 580 kHz. The excess 80 kHz is about equally split so that the full CCW frequency is about 40 kHz below the bottom band edge, i.e. 3460, 6760, 13960 kHz, etc. The remaining 40 kHz extends to about 4040, 7540, 14540 kHz, etc. The overrun can be made to favor either the low or high band edge by merely touching up the slug in L2, the slug nearest the aluminum cover plate. (See Figure 2, Bottom View, page 3-7.) Hence out-of-band operation on MARS may be covered with the PTO up to about 80 kHz. If this is done, it must be remembered that the unequal overruns will be present on all bands.

OFFSET ADJUSTMENT FOR 21.0 and 28.0 MHz BANDS

To eliminate band edge birdies on these two bands, the crystal oscillator frequencies are chosen 10 kHz lower than what normally would be needed compared to the other bands. The variable PTO oscillator compensates for this deviation by switching varactor diode D3 into the circuit by means of switch S1B, so that when switching from band to band, the kHz portion of the digital reading will not materially change. The amount of varactor capacitance inserted is controlled by the value of dc voltage applied through potentiometer R22. To set this adjustment, proceed as follows:

- 1.) With power removed from the transceiver, carefully remove four flat head screws at the outside corners of the VFO top cover plate.
- 2.) Lift cover gently so that PC assembly attached is not damaged. Raise left edge high enough so that slot in lower shield plate is accessible. Potentiometer R22 is immediately below the slot and can be adjusted with a small-bladed screwdriver. R22 is a vertically mounted trimpot and adjustment is accomplished by left or right movement of the top portion of its plastic knob.
- 3.) Making sure no portion of PC board is in contact with chassis, apply

power to the transceiver. Set BAND switch to 14.0 and digital readout to 14.000 0.

- 4.) Switch BAND switch to 21.0 position and without moving setting of main tuning knob, adjust R22 so that readout is 21.000 0 MHz.

#### MIXER OUTPUT ADJUSTMENTS

The double tuned circuits connected to mixer output on all but the 14.0 MHz band are wide band, overcoupled resonant circuits that are best aligned using a sweep oscillator system. Because they are wide band, realignment is seldom necessary except in the case where a tuned circuit component is replaced. Only if realignment is definitely indicated should the following alternate procedure be used.

- 1.) Connect an rf oscilloscope and/or rf voltmeter to VFO output. Refer to Figure 2 for location of this terminal.
- 2.) Capacitors C5 through C10 are used in conjunction with transformer T1 to peak the VFO output on all bands except 14.0 MHz. This band derives its output directly from the 5.0 to 5.5 MHz PTO assembly. To gain access to these trimmer capacitors it is necessary to first remove the VFO top plate as outlined in Step 2 in the OFFSET ADJUSTMENT paragraph above. The inner shield should then be removed by removing the four screws holding it and then slipping the plate out toward the left top edge of the sub-chassis.
- 3.) 3.5 and 21.0 MHz band alignment:
 

Since the output frequency of the 3.5 MHz band is 12.5 to 13.0 MHz and of the 21.0 MHz band 12.0 to 12.5 MHz, these two bands have a common set of trimmer capacitors, C7 and C10. The VFO mixer output curve then is broadbanded to cover 12.0 to 13.0 MHz. The desired curve should show peak outputs at 12.0 MHz and 13.0 MHz with a slight saddle in between, because of the overcoupled design. Proceed as follows:

  - A.) Set BAND switch to 3.5 MHz and dial to 4.000 0 MHz.
  - B.) Peak C7 and C10 for maximum voltage reading on meter or oscilloscope. Note reading.
  - C.) Set BAND switch to 21.0 MHz and dial to 21.000 0.
  - D.) Repeak C7 for maximum reading.
  - E.) Recheck values of output voltage at 4.000 MHz and again peak C10. (There is some interaction on tuning between the two trimmers.) Check to see whether peaks at 4.000 0 and 21.000 0 are approximately equal and whether output slightly decreases as you tune down from 4.000 0 to 3.5000 and up from 21.000 0 to 21.500 0.
  - F.) Touch up C7 and C10 until desired curve is obtained.
- 4.) 7.0 MHz alignment:
  - A.) Set BAND switch to 7.0 MHz and dial to 7.200 0.
  - B.) Adjust C6 and C9 for peak output.
  - C.) Check output for uniformity from 7.000 0 to 7.300 0 MHz. Touch up C6 and C9 as necessary to obtain constant output.
- 5.) 28.0 MHz alignment:
 

In order to properly adjust C5 and C8, it is necessary that the 29.5 MHz crystal, Model 213, be installed. The double peaks should occur at 28.000 0 and 30.000 0 MHz on the digital readout with a slight dip in between. Proceed as follows:

  - A.) Set BAND switch to 28.0 MHz and dial to 28.000 0.
  - B.) Adjust C5 and C8 for maximum output.
  - C.) Reset frequency to 30.000 0 MHz and readjust C5 for max. Check for peaks at 28.000 0 and 30.000 0 and readjust as needed to obtain proper curve.
- 5.) Output voltage on all bands should be between 200 and 300 mV, rms at all frequencies and on all bands. Set lowest output obtained, usually the 10 meter band, to 200 mV with R27, the CRYSTAL INJECTION potentiometer.

meter. Check across all bands and frequencies so that this control setting yields at least 200 mV. Caution: Too high an output level will not improve performance but will increase unwanted mixer products.

### MIXER BALANCE

To balance mixer input for minimum crystal oscillator feedthrough, proceed as follows:

- 1.) Connect rf voltmeter to VFO output.
- 2.) Disable PTO by connecting a .01 mfd capacitor between the output lug of the PTO assembly and chassis. Refer to Figure 2 for location, and be aware that there is also a VFO OUTPUT, which should have the meter connection. The PTO terminal is located on the small aluminum housing.
- 3.) Set BAND switch to 28.0 MHz and adjust R2 potentiometer for minimum voltmeter reading. Access to R2 is through hole in side sub-chassis near feedthrough terminals, or directly if VFO top and inner shield are removed. Remove .01 capacitor before re-assembly.

### SEMICONDUCTOR VOLTAGE READINGS - (BAND switch 3.5 MHz position.)

Transistor	Collector Drain	Base Gate	Emitter Source
Q1 MOSFET	12.8	6.8	7.1
Q2	12.8	7.1	6.4
Q3 MOSFET	7.8	-2.2	0
Q4	5.4	1.2	0.5
Q5	8.0	2.2	2.3

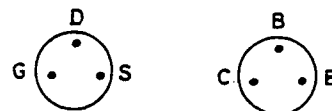

### IC-1

Pin	Receive	Pin	Receive
1	7.0*	8	10.2
2	6.2	9	-
3	6.1	10	10.2
4	6.8	11	-
5	3.8	12	13.0
6	13.1	13	-
7	13.1	14	0

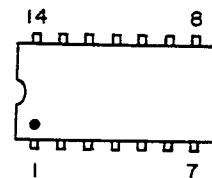

IC-1

Semiconductor pins  
viewed from top of  
PC board.

\*Depends on setting of R2.

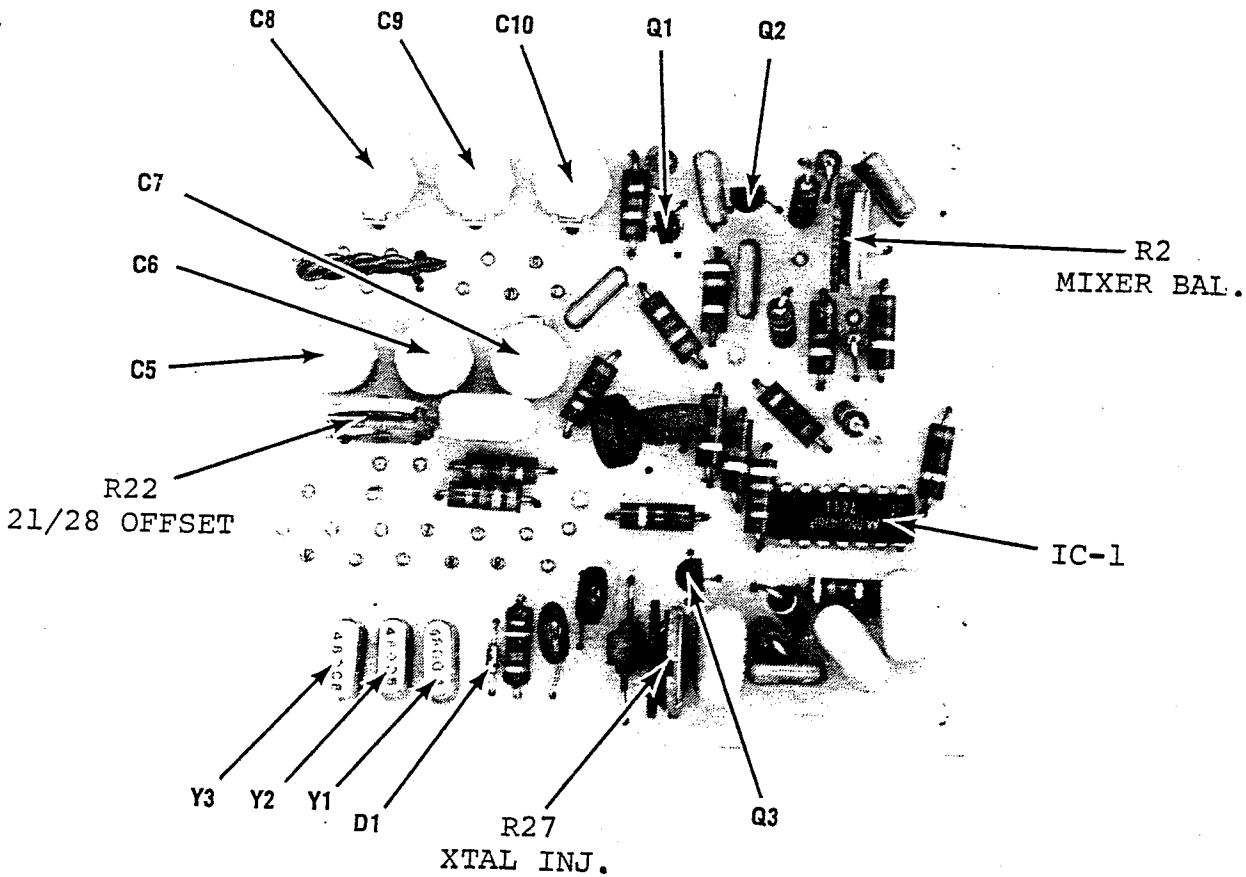
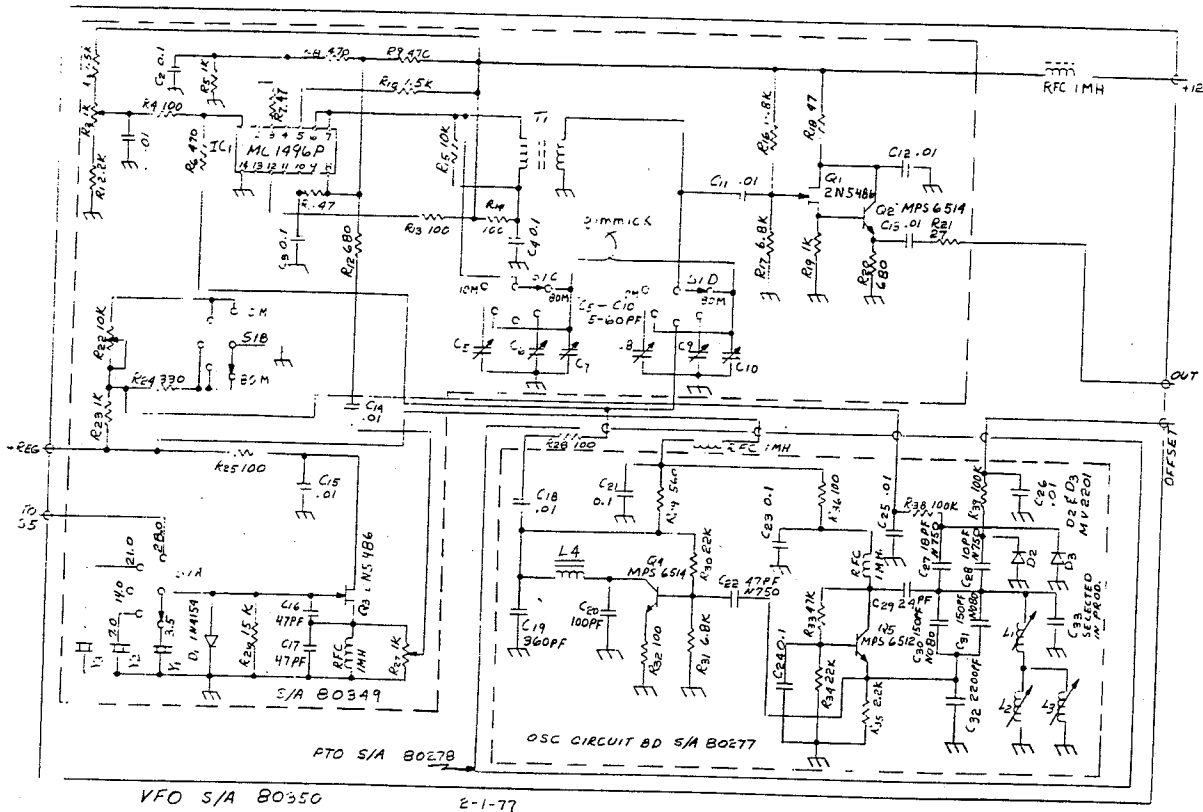

## DIGITAL READOUT

The frequency counter and digital display section of Model 544 consists of four separate printed circuit assemblies located throughout the chassis. The large scale integrated circuit and interfacing transistors to the display assembly are contained on assembly 80348, mounted on the under-side of the VFO top cover plate. The six digit display, 80347, is secured to the front upper portion of the VFO sub-chassis. The preset counter diode matrix, which determines the first two digits information, is mounted with a portion of the BAND switch and is the rear-most inner switch deck in the VFO assembly. This assembly is designated 80365 BANDSWITCH. The fourth assembly, 80346, is a plug-in board located on the underside of the chassis near the rear panel. It contains the counter time base oscillator and necessary divider stages, a signal preamp and ten-to-one prescaler and a voltage regulator which supplies +5 volts.

Since this portion of the transceiver is highly complex and contains MOS and CMOS integrated circuits that are susceptible to damage from static burn-out if improperly handled, the following information will be limited to a general description of circuit operation.

Servicing information will give sufficient information to locate a faulty assembly, but not specific semiconductor voltage readings, except for plug-in assembly 80346. It is suggested that a complete defective assembly be replaced instead of individual components. Full schematics and individual photos are included for those with adequate digital knowledge and test equipment. Many of the circuits carry pulse signals so that straight dc measurements cannot be made. Rather, dc oscilloscope analysis is the only way to properly troubleshoot these circuits. Since it is not within the scope of these instructions to present detailed waveform analysis, general guidelines for troubleshooting are given, along with dc voltage measurements where they are valid.

THEORY OF OPERATION

The counter incorporates the latest in large scale integration. MOSTEK type MK50398N circuit accomplishes all of the counting, latching, multiplexing and output decoding and driving functions on a single chip. This IC is located on the 80348 assembly mounted on the under-side of the VFO top plate.

Input signal from the VFO output is first passed through source follower Q1 on the 80346 TIME BASE-PRE AMP assembly. (The digital readout portion of the main chassis wiring diagram is reproduced in this section for clarity.) From the source follower, the signal is then amplified by IC-1 on this assembly and then divided by decade divider IC-2. Since VFO frequencies range between 5.0 and 21.0 MHz, the scaled down output which is applied to the LSI (Large Scale Integrated) circuit ranges between 500 kHz and 2.1 MHz.

Time base oscillator IC-5 on 80346 operates at a crystal controlled frequency of 5.24288 MHz. This IC also divides the output by a factor of  $2^{20}$ , resulting in an output of 5 square waves per second. This timing signal gates the scaler on and off so that the input is counted for one tenth of a second (100 milliseconds). During the remaining 100 ms the counter preset information and the transfer of the counter information to display circuits is carried out through two timing pulses, STORE and LOAD terminals on 80346, applied to pins 10 and 24 of the LSI circuit IC-1 on 80348 LOGIC assembly. These pulses are derived from IC-4 on 80346. It is a dual monostable multivibrator. Input to this circuit is also from the 5 Hz square wave. The pulse widths are controlled by R17 and C12 (load pulse) and R16 and C13 (store pulse). The load pulse is positive and typically 5 ms long while the store pulse is negative and 50 us long. Trimmer C16 in the crystal oscillator circuit serves to accurately set the time base frequency.

The preset information needed to convert the readout indication from the actual counted frequency to the operating frequency (9 MHz away) is provided through the four program lines, pins 11 through 14 on the LSI chip. Only pins 11 and 14 are required to be switched for the various bands. The programming diodes are located on 80365 BANDSWITCH assembly. On the 3.5 and 7.0 MHz bands, 91.000 0 is preset by diodes D1, D2 and D3. On the remaining bands, 9.000 0 is preset by diodes D4 and D5.

IC-3 on assembly 80346 is a voltage regulator which provides +5 volts to operate IC-2, the TTL 7490 decade counter. All other circuits are fed from the +12 volt line through appropriate decoupling circuits.

DISPLAY assembly 80347 consists of six 0.4" high LED, seven segment numerical displays mounted on a PC board. The board is painted black prior to installation of the readouts. Five readouts are red and the least significant digit is green. All voltages for the display come from LOGIC assembly 80348. The display is multiplexed in the LSI circuit and frequency runs typically between two and three kHz, as determined by C5 on 80348. Interface driver transistors between the common anode LED numerals and the LSI circuit are contained on LOGIC assembly 80348. Q1 through Q7 provide the seven segment signals and Q8 through Q19 the digit enabling signals from the multiplexer to the anodes.

#### SERVICING HINTS

Use the following procedures to locate the faulty assembly. If well versed in digital techniques, check waveform and signal paths as indicated.

- 1.) Check all dc voltages given for TIME BASE-PRE AMP assembly 80346. If any is more than 20% different than value indicated, look to this area of the circuit for faulty component.
- 2.) If all dc measurements are within normal range, determine probable malfunctioning area by analyzing trouble symptoms. If, for example, one digit is dark or always reads 8, trouble is indicated in the particular digit enable circuitry or the LED itself. Or, if any one bar of the seven segments is dark or lit all of the time on all six digits, look to the particular driver transistors and associated wiring for that particular segment.
- 3.) With oscilloscope check signal path at these locations:
  - A.) No indication on digital readout may indicate input signal from VFO is not passing through Q1, IC-1 or IC-2 on 80346. Or, IC-2 reset line, pin 2, may inhibit signal from reaching OUTPUT pin terminal and input to LSI.
  - B.) Check operation of crystal time base oscillator, output from divider, pin 12 of IC-5, and output pulses from monostable multivibrators, pin terminals marked STORE and LOAD.
  - C.) Since multiplexed readout contains six digits, the enable pulse to each digit should have a pulse width equal to one sixth of the time for one complete scan. Scan frequency is determined by the 750 pF capacitor C5 on 80348 LOGIC board.
- 4.) Correct preset information from 80365 BANDSWITCH assembly results in the digits to the left of the decimal point displaying correct MHz for the various bands. If any of these do not indicate correctly, check wiring between this assembly and 80348 and condition of diodes.

#### 80348 LOGIC BOARD

This assembly is difficult to access for test purposes and therefore only qualified technicians should attempt work on it. The pattern side of the PC board can be utilized for voltage readings by removing the assembly from the VFO top plate.

IC-1, the LSI circuit, should have approximately 11 volts at pins 1, 2 and 28. Pins 15, 17 and 26 should be at chassis GND potential. All other pins have pulses and cannot be measured with a dc voltmeter.

Transistors Q1 through Q13 should have their emitters at chassis GND. Emitters of Q14 through Q19 should read 13 volts. All bases and collectors contain pulses.



Semiconductor Voltage Readings on 80346 TIME BASE PRE AMP

<u>Q1</u>	Drain	13.3
	Gate	0
	Source	2.4

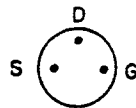

Pin	IC-1	IC-2	IC-3	IC-4	IC-5
1	12.5	DNM	0	0	DNM
2	12.1	DNM	5.3	13.1	0
3	0	5.1	5.1	13.2	0
4	4.0	0	5.1	DNM	5.6
5	4.4	5.1	5.1	13.2	13.3
6	4.0	0	7.1	DNM	5.4
7	0	0	0	DNM	0
8	12.5	DNM	0	0	0
9	-	DNM	5.1	DNM	0
10	-	0	5.3	DNM	DNM
11	-	DNM	13.3	DNM	DNM
12	-	DNM	13.3	0	DNM
13	-	0	6.6	13.2	DNM
14	-	DNM	0	DNM	DNM
15	-	-	-	0	DNM
16	-	-	-	13.2	13.3

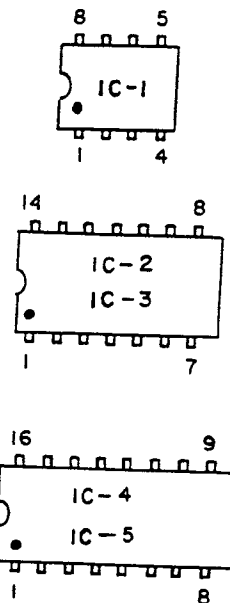

DNM = Do Not Measure. Pulses present.

Semiconductor pins viewed from top of PC board.

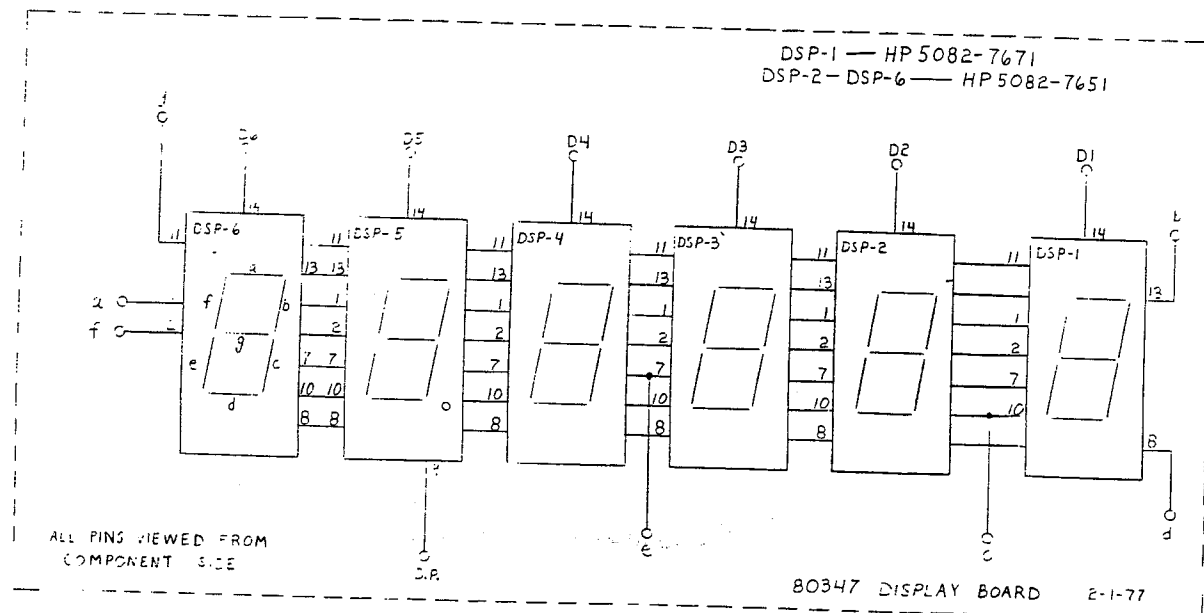
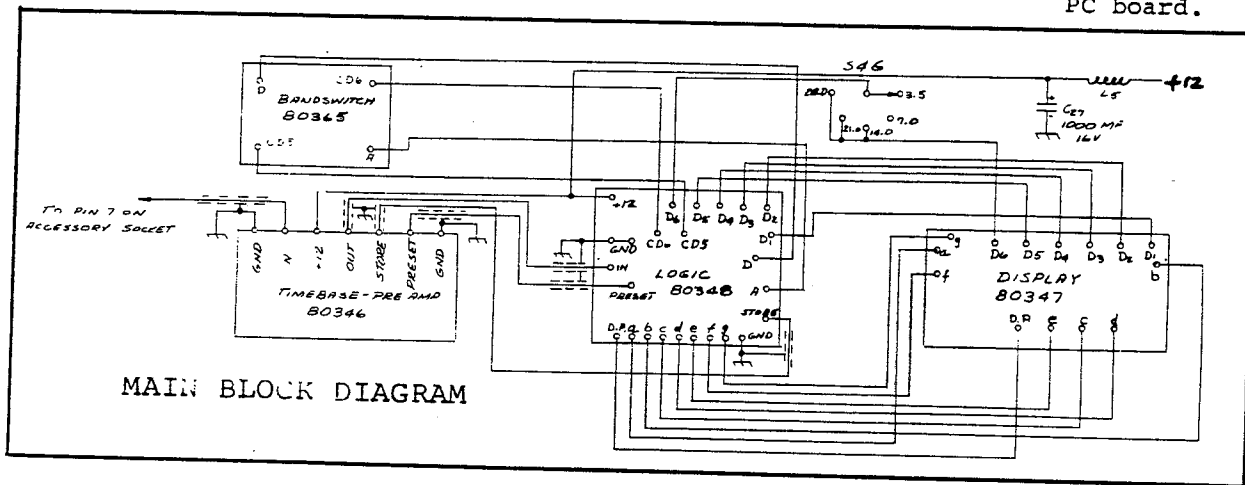

ALL PINS VIEWED FROM COMPONENT SIDE

80347 DISPLAY BOARD 2-1-77

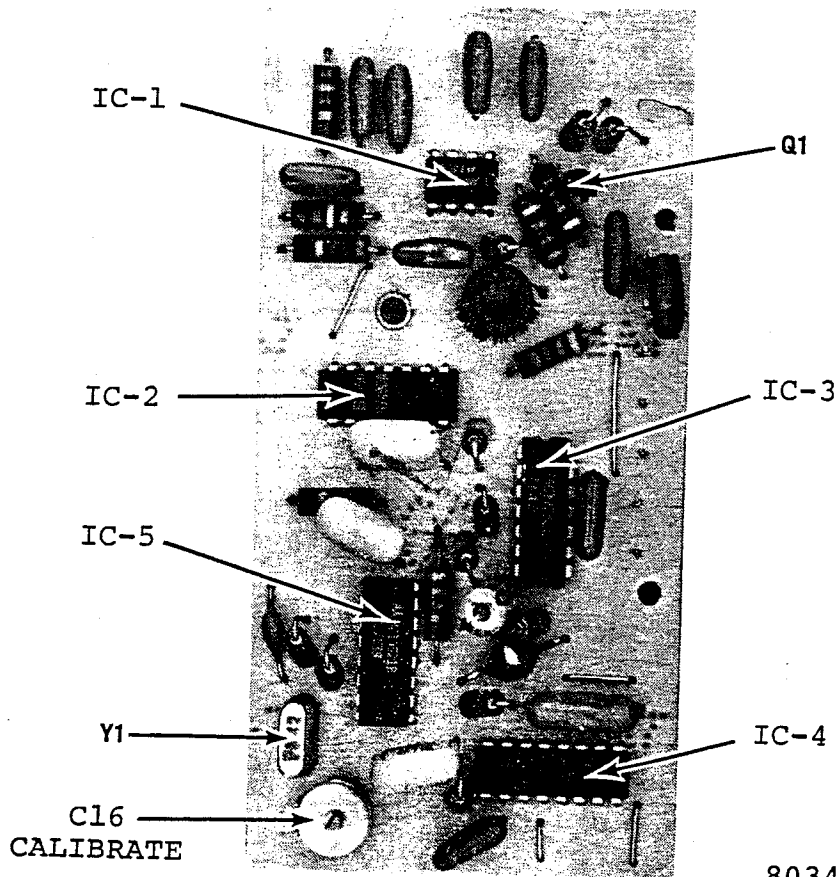
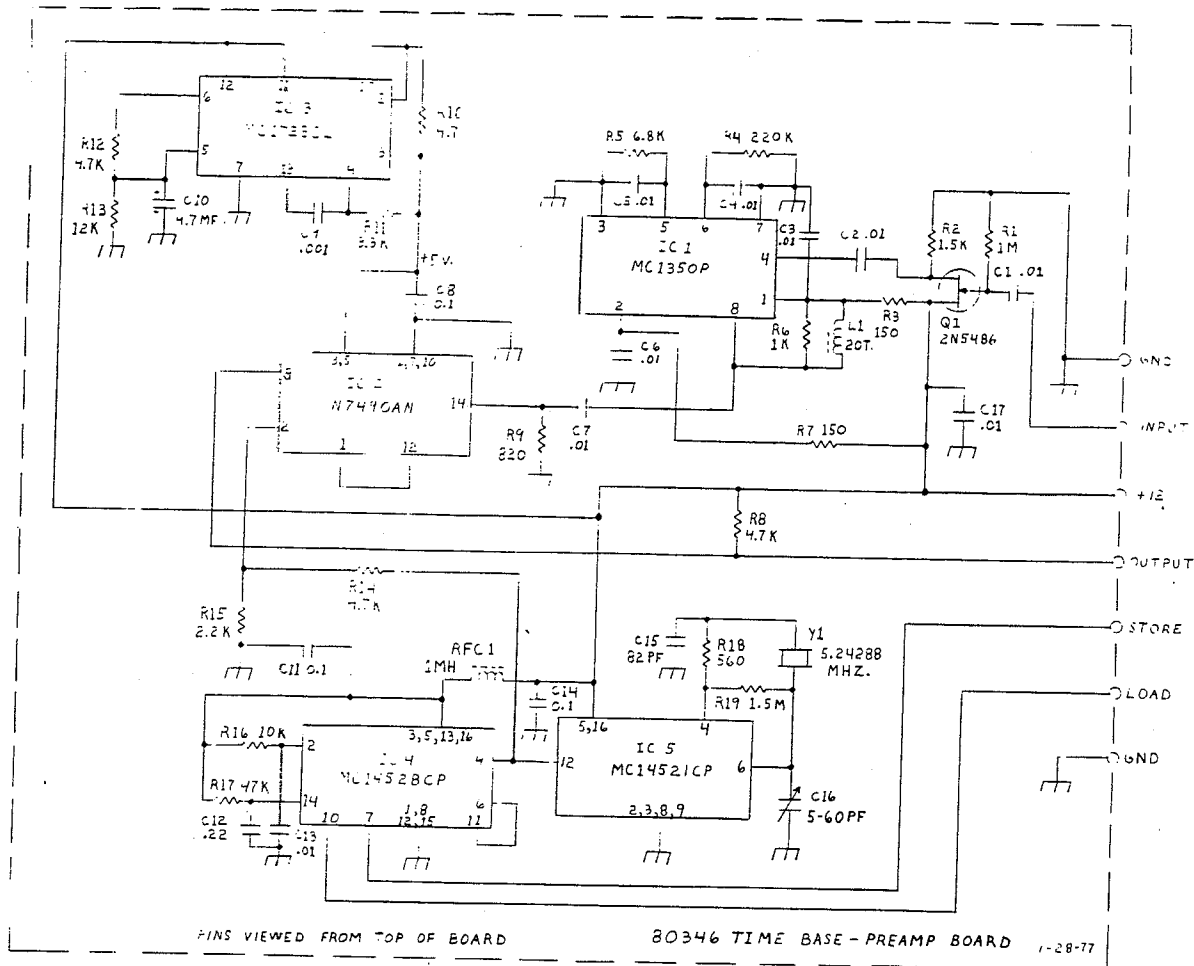

80346 TIME BASE - PREAMP

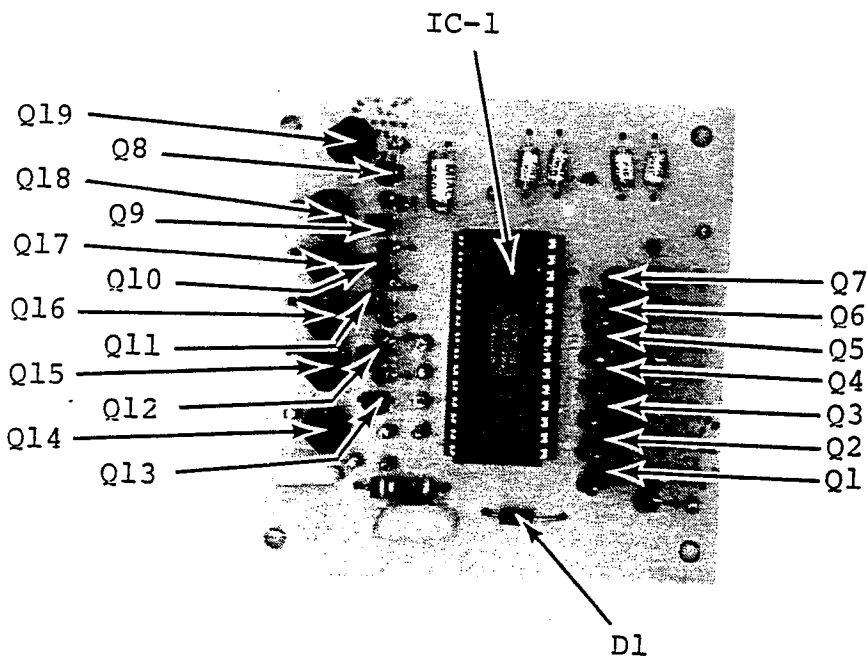
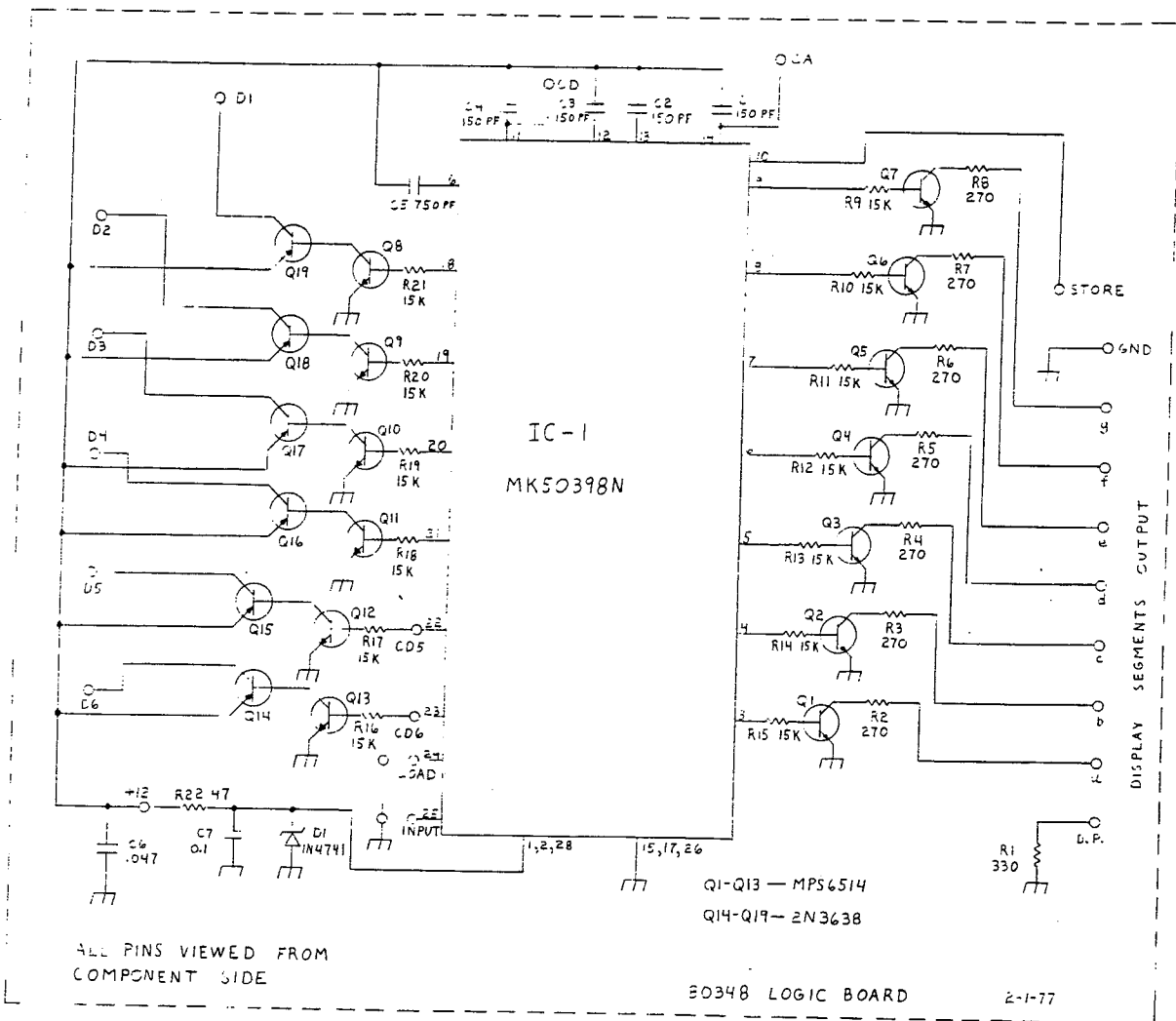

80348 LOGIC

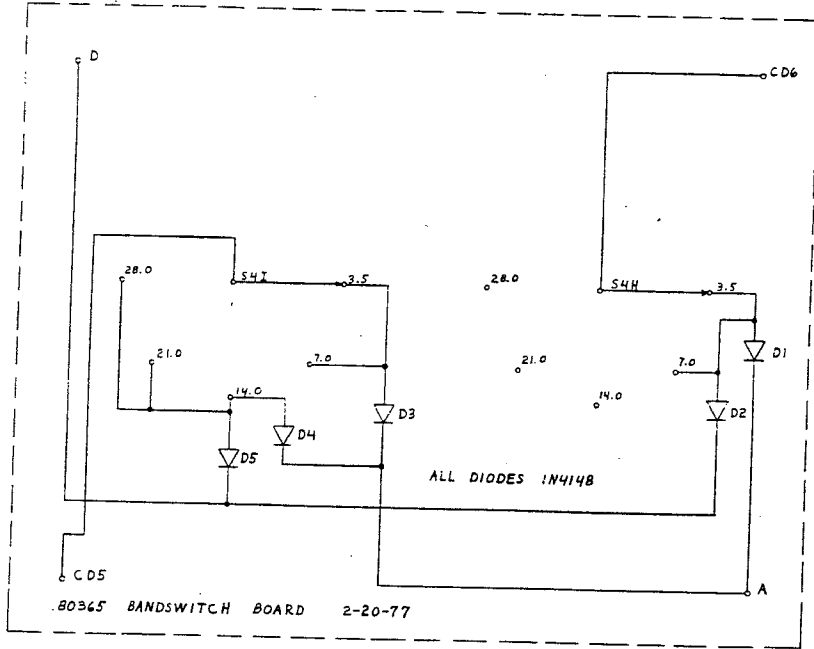

80365 BANDSWITCH

80287 TX-RX MIXER

Receiver Mixer - Integrated circuit IC-1 is a double balanced mixer which converts the input signal from the rf amplifier to the 9 MHz i.f. frequency by either adding to or subtracting from the VFO frequency. The VFO signal is applied via the lead to the ACCESSORIES plug from either an external VFO connected to the plug or through the jumper on pins 6, 7 and 8 and the internal VFO when the jumper plug is inserted. The mixer output is loaded with a tuned circuit, C5 and L3. L3 is peaked for maximum noise pickup when the receiver is tuned off station, or with the antenna disconnected.

The mixer balance potentiometer, R1, should be set to null any received birdie that may be received, without antenna connected, at about 21.320 MHz. Tune  $\pm$  5 kHz of this frequency to determine if R1 needs setting.

Diode D1 acts to short the output in the transmit mode by being forward biased with the removal of the "R" voltage from the circuits.

Transmitter Mixer - Integrated circuit IC-2 combines the VFO frequency with the 9 MHz carrier signal that is general on SSB GENERATOR assembly, resulting in an output signal at the operating frequency. As in the receiver mixer, the VFO signal can be from either an external source or from the internal VFO. In CW the amplitude of the 9 MHz signal is set by the DRIVE control and in SSB audio information unbalances the 9 MHz signal with the proper information, both functions being performed on the SSB assembly. Hence the mixer output contains all needed modulation characteristics.

Only one adjustment is needed in the mixer. Mixer balance potentiometer R19 is adjusted so that residual transmitter output signals are minimized as observed on an oscilloscope connected across the ANTENNA jack. Set frequency to 28.0 MHz, MODE switch to LOCK position, DRIVE control fully CCW and use dummy load.

Pin Voltage Readings - (SB-N mode, DRIVE fully CCW, RF gain fully CW)

Pin	Transmit	Receive	Pin	Transmit	Receive
GND	0	0	GND	0	0
Rx VFO	.05	.05	R	0.6	12.8
Rx IN	0	11.5	Rx 9 MHz	0	0
T	10.4	0.2	Tx 9 MHz	0	0
OUT	0	0	+12	13.8	13.8
+12	13.8	13.8	Tx VFO	0.1	0.1
GND	0	0	GND	0	0

Semiconductor Voltage Readings

Pin	IC-1		IC-2	
	Transmit	Receive	Transmit	Receive
1	0.2	3.5	6.5	6.7
2	0	2.7	5.8	6.2
3	0	2.7	5.8	6.2
4	0.2	3.4	6.5	6.7
5	0.5	1.2	3.0	0.2
6	0.7	11.8	12.8	13.4
7	-	-	-	-
8	0.4	6.5	9.8	10.0
9	-	-	-	-
10	0.4	6.5	9.8	10.0
11	-	-	-	-
12	0.7	11.8	12.8	13.4
13	-	-	-	-
14	0	0	0	0

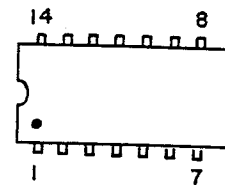

IC pins viewed from top of PC board.

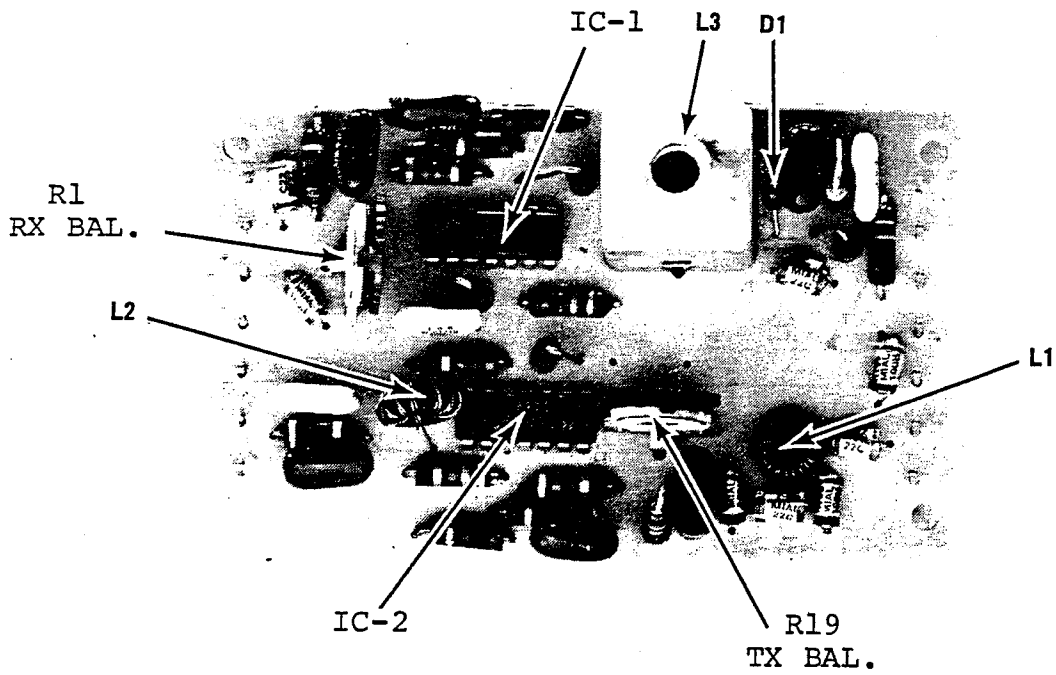
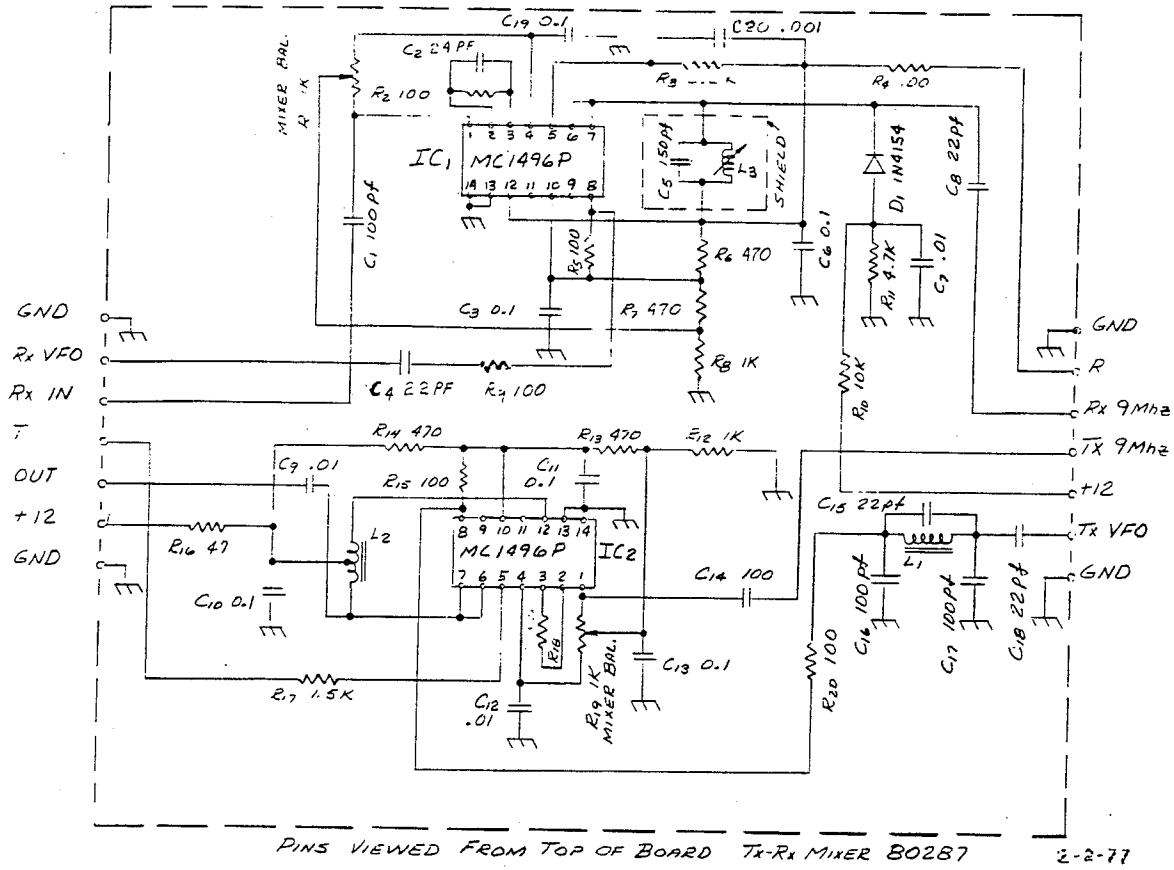

80287 TX-RX MIXER

## 80279 I.F.-AGC

The 9 MHz i.f. amplifier utilizes two stages, both of which are gain controlled for AGC. Input signal is derived from the output of the receiver mixer after being passed through the 8 pole crystal lattice filter on SSB GENERATOR assembly. PIN diodes D1, D2 and D3 present variable capacitances across the signal path in the i.f. stages. The amount of shunting is determined by the amount of AGC voltage developed in the DC darlington stage, Q4 and Q5. Output of the i.f. amplifier is converted into an audio signal by product detector, Q3. It then goes to the FILT IN terminal and is returned through the FILT OUT terminal. If Model 245 CW filter is used, it connects between these two terminals. If no filter is used, these terminals are jumpered together on the filter socket.

Audio signal applied to the FILT OUT terminal is amplified in one section of dual op-amp IC-1, and fed to the AUDIO terminal. The second op-amp further amplifies the signal for AGC purposes. The S-Meter is driven by the AGC darlington output stage, as well as the PIN diodes, in the receive mode, but is disconnected when transmitting by blocking diode, D4.

Three adjustments are required on this assembly. The first two, i.f. transformers T1 and T2, are peaked for maximum S-Meter reading while receiving a weak signal. Maintain a meter reading less than S-5 by detuning the RESONATE control so that AGC action is held to a minimum.

S-Meter calibration is accomplished by setting potentiometer R20 to an S-9 reading when 50 uV signal at 14.100 0 MHz is applied to ANTENNA terminal. R20 should be adjusted after RESONATE control is peaked and main tuning adjusted for maximum meter deflection.

Pin Voltage Readings - (Receive mode, no signal conditions.)

Pin	Transmit	Receive	Pin	Transmit	Receive
GND	0	0	GND	0	0
IN	0	0	FILT IN	0	0
AUDIO	0	0	R	0	12.1
T	10.4	0.2	+ REG	8.0	8.0
+12	13.8	13.8	PFO	6.5	6.5
S MTR	0	0	FILT OUT	0	0
GND	0	0	GND	0	0

Semiconductor Voltage Readings

Transistor	Collector Drain	Base Gate 1	Emitter Source	Gate 2
Q1	13.7	1.0	0.3	
Q2	13.3	1.8	1.1	
Q3 MOSFET	3.0	0.6	2.0	2.0
Q4	13.8	1.2	0.8	
Q5	13.8	0.8	0.2	
Q6	1.2	.05	0	

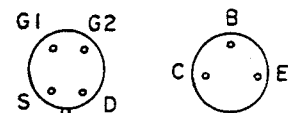

Transistor pins viewed from top of board.

IC-1

Pin	Volts	Pin	Volts
1	7.0	8	-
2	6.8	9	13.8
3	-	10	6.8
4	0	11	-
5	-	12	7.0
6	7.0	13	13.8
7	7.0	14	-

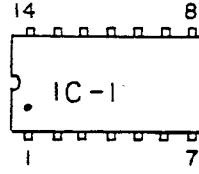

IC pins viewed from top of board.

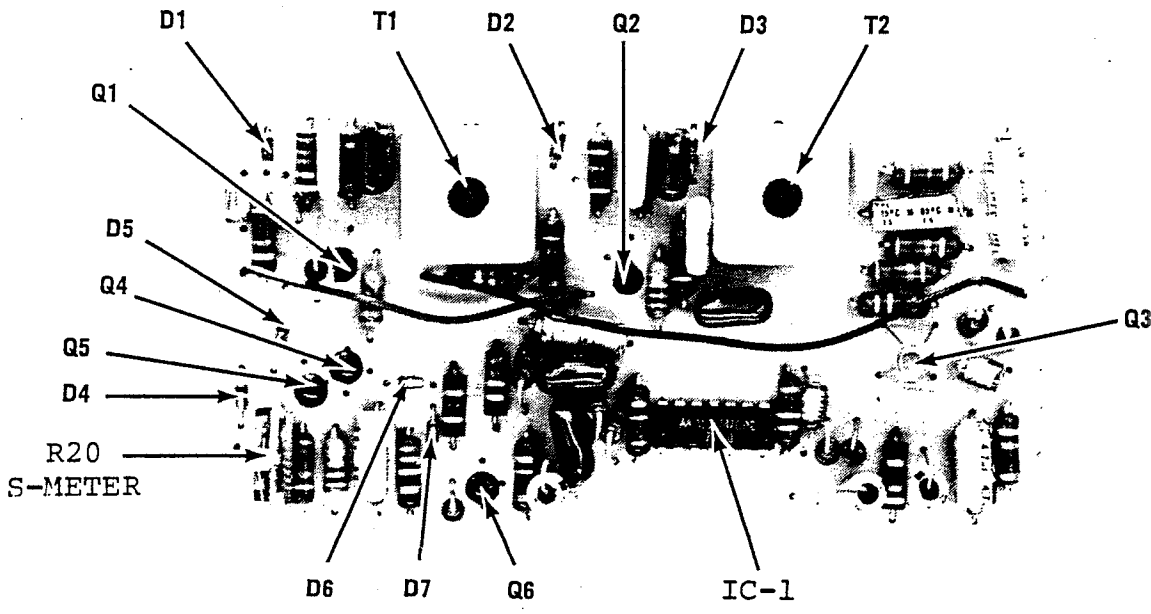
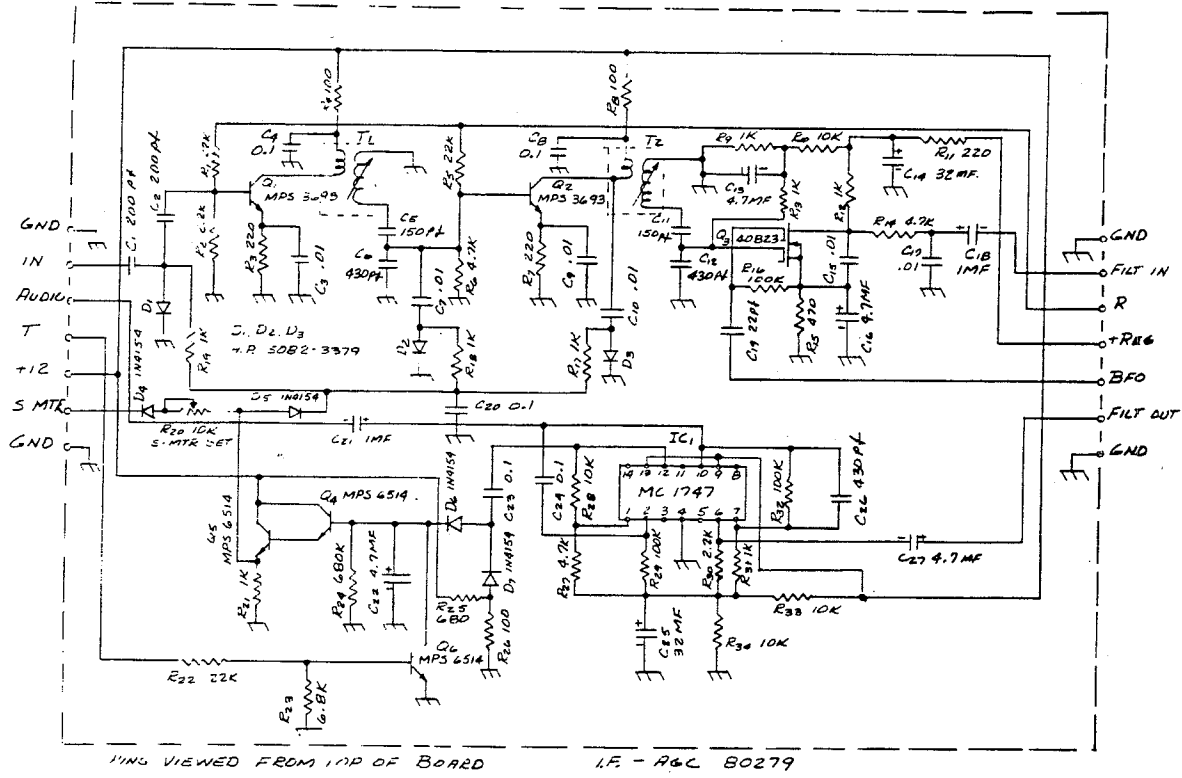



## 80274 AUDIO POWER AMPLIFIER

Integrated circuit, IC-1, contains the complete audio power and preamplifier. Input is applied to pin 2 and output taken from pin 8. Input signal may be from one of two sources, the received signal which is applied to the INPUT terminal and passes through the muting circuit when open or from the sidetone oscillator consisting of Q2 and Q3.

Input signal is shorted to ground whenever muting transistor, Q1, is put into the conducting state. This occurs in the transmit mode by the application of the "T" voltage to its base circuit through D1. C1, R1 and R2 form a short RC circuit to slightly delay the turn-on time of the audio signal.

The sidetone oscillator is a relaxation type made up of unijunction transistor Q2. C5, in conjunction with R8 and pitch control R7 determine the frequency. Q3 is the turn-on switch, controlled by the application of the SIDETONE voltage to its base. The SIDETONE control voltage is the "T" voltage, but it is applied only in the CW position of the MODE switch. Sidetone level is adjusted by R5. The sidetone signal is prevented from being muted along with the incoming signal by isolating resistor R4.

Pin Voltage Readings - (No signal conditions, CW mode, Drive fully CCW)

Pin	Transmit	Receive
GND	0	0
T	10.4	0.2
INPUT	0	0
OUTPUT	0	0
GND	0	0
SIDETONE	10.4	0.2
+12	13.8	13.8

Semiconductor Voltage Readings - (CW mode.)

Transistor	Collector		Base		Emitter	
	Transmit	Receive	Transmit	Receive	Transmit	Receive
Q1	0	0	0.7	0	0	0
Q2	8.3	8.1	4.5	2.4	0	0
Q3	0	0	0.7	0.2	0	0

Integrated Circuit - (CW mode.)

Pin	Transmit	Receive
1	7.0	7.0
2	0	0
6	0	0
7	0	0
8	6.8	6.8
9	0	0
13	0	0
14	13.8	13.8

Tab is ground.

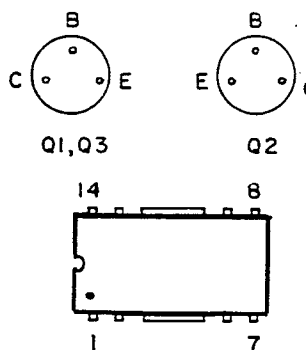

Semiconductor pins viewed from top of PC board.

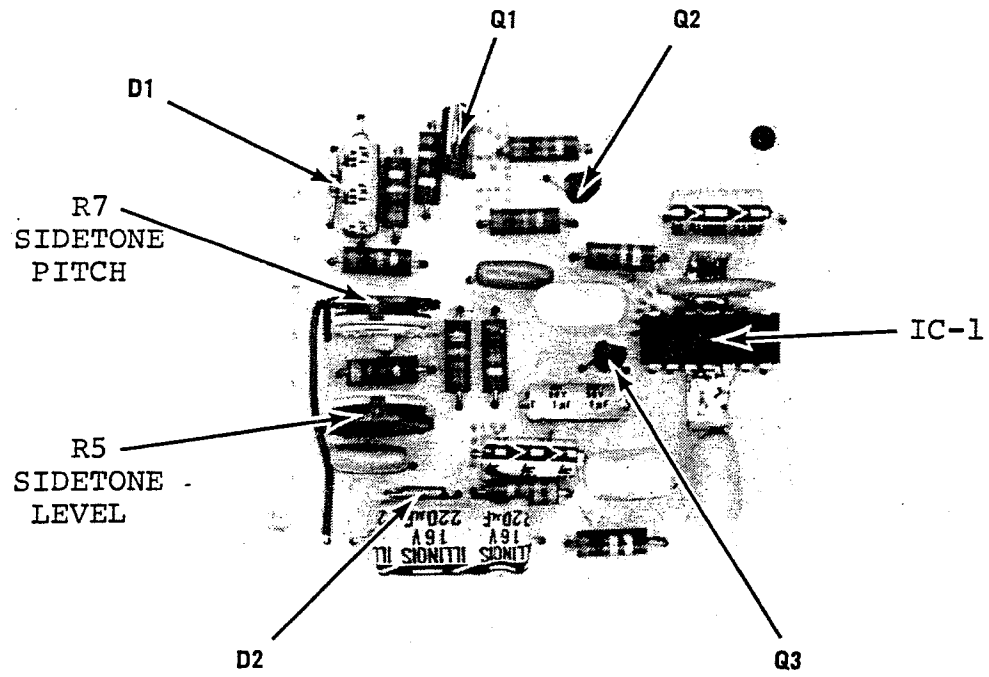
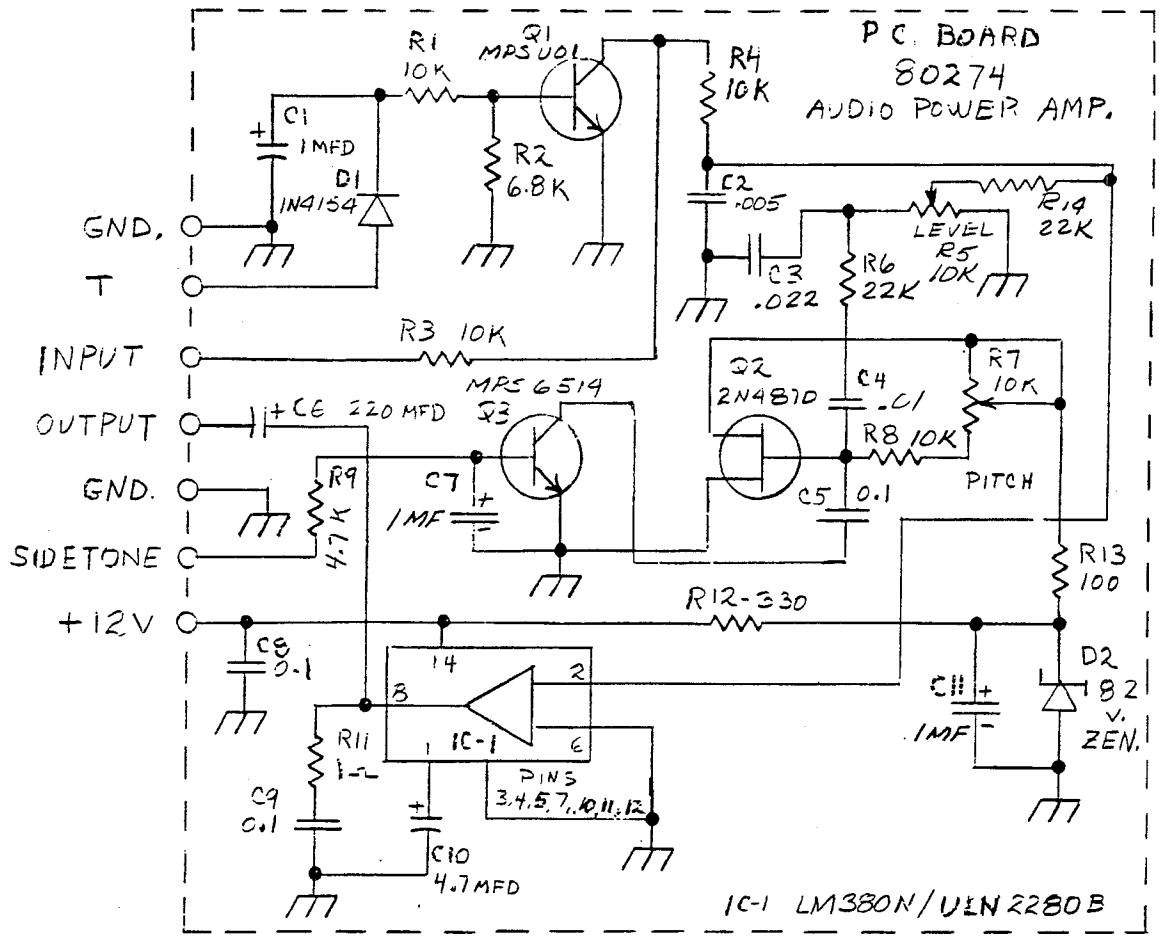

80274 AUDIO AMPLIFIER

This assembly contains the eight pole crystal filter subassembly, which is used in both the receiver i-f chain and the transmitter SSB generator, carrier (BFO) crystal oscillator which operates at 9 MHz, balanced modulator for SSB generation and a two stage microphone audio amplifier.

No alignment of the crystal lattice filter is necessary. In the receive mode, the filter is inserted between the RX MIXER output and the i-f amplifier input to achieve the desired selectivity. When transmitting, the output of the balanced modulator, IC-1, is passed through the filter before being sent to the TX MIXER, to block the carrier and unwanted sideband.

Q3 is the carrier oscillator operating at approximately 9 MHz. Its exact frequency is determined by which of three trimmer capacitors, C1, C2, C3, are placed in the crystal circuit. C1 is in the circuit under all MODE switch conditions and sets the carrier to the desired frequency on the high side of the lattice filter skirt. (This position is used in the SB-R mode.) In this mode, both C2 and C3 are removed from the crystal circuit by transistor switches Q1 and Q2 respectively. Their bases are grounded through the MODE switch.

In SB-N, both of these capacitors are inserted into the circuit by removing the base grounds, and the three capacitors in parallel set the oscillator frequency down on the opposite (low frequency) filter skirt. In the CW modes, C3 is removed via Q2 so that the carrier frequency increases 750 Mz into the filter passband. C1 and C2 determine this setting.

Output from the carrier oscillator is fed to the BFO terminal and the product detector on the IF-AGC assembly, and also to balanced modulator IC-1 where it is mixed with an audio signal from microphone amplifier IC-2. Output in the SSB modes is a double sideband, suppressed carrier signal, whose unwanted sideband is removed in the lattice filter. Further carrier reduction also occurs in the filter.

For CW operation, the balance of IC-1 is upset when terminal CWU is grounded through the MODE switch. This also is the case in LOCK mode. Audio from the microphone channel is eliminated by this same shorting procedure. The amount of "T" voltage (controlled by setting of DRIVE control in CW mode) applied to pin 7 of the balanced modulator determines the gain of the modulator and hence the level of carrier signal applied to the TX-MIXER.

Transformer T1 is factory adjusted to the crystal lattice filter using an elaborate sweep system and should not be field adjusted. To do so would upset the flatness of the passband response with resulting transmitted and received audio coloration.

#### CARRIER OSCILLATOR ALIGNMENT

Proper alignment of C1, C2 and C3 requires use of a frequency counter and either an rf VTVM or oscilloscope with response to 10 MHz. These capacitors should not be readjusted on general principles but only after it is definitely found that the carrier is not where it should be on the passband curve or that the CW frequency is not 750 Hz up from the SB-N carrier frequency. To make the adjustments, proceed as follows:

1. Connect counter to junction of R5 and R6 in emitter circuit of Q3. If there is no DC blocking capacitor in counter input, connect through .01 uF.
2. Connect either rf VTVM or 'scope to ANTENNA jack. Load with dummy load.
3. Set MODE switch to SB-R position and DRIVE control fully counterclockwise.
4. Completely unbalance modulator by setting CARRIER BAL. potentiometer, R13, to either extreme.

5. Temporarily set C1 for frequency reading of 9,001, 700 Hz. This places carrier approximately in center of passband.
6. Short PTT line to chassis to place TRITON in transmit mode.
7. Advance DRIVE control so that output of 20 volts, rms is read on VTVM or 60 volts, peak-to-peak is displayed on oscilloscope.
8. Readjust C1 to decrease capacitance and increase frequency to point where output decreases to 1 volts, rms on VTVM or 3 volts, p-p on 'scope. This represents a point 26 dB down on the skirt.
9. Set MODE switch to SB-N, temporarily set C2 to half capacitance and adjust C3 so that output is 1 volt, rms on VTVM or 3 volts, p-p on 'scope. Frequency now should be on low skirt. Note and record frequency.
10. Set MODE switch to LOCK. Adjust C2 so that frequency is 750 Hz higher than in step 9. Amplitude of output should return to approximately that on step 7.
11. Repeat steps 8 through 10 in sequence until no further adjustments are necessary. C2 and C3 both determine low skirt frequency and both have a slight effect on C1. Readjustment of all three is necessary after any one is altered.
12. With MODE switch in SB-N position, and without changing DRIVE setting of previous steps, turn up sensitivity of 'scope or VTVM. Null CARRIER BAL. potentiometer R13 for minimum residual carrier.

13. Remove jumper from PTT line.

Pin Voltage Readings\* (No signal, DRIVE fully CCW, OFFSET on.)

Pin	Transmit SB-N	Receive SB-N	Receive SB-R	Receive CW-2	Receive LOCK
GND	0	0	0	0	0
LSB	7.2	7.2	0	7.2	7.2
CW	13.8	13.8	0	7.2	0
CWU	6.2	6.2	6.2	0	0
T	10.4	0.2	0.2	0	0.5
+ REG	9.0	9.0	9.0	9.0	9.0
BFO	6.9	6.9	6.9	6.8	6.8

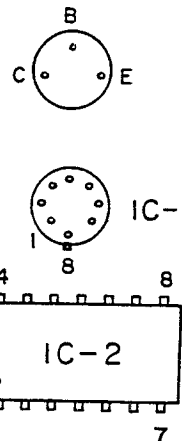

Semiconductor Voltage Readings - (SB-N mode, DRIVE fully CCW.)

Pin	IC-1		IC-2	
	Transmit	Receive	Transmit	Receive
1	5.9	6.2	4.3	4.3
2	3.5	0.1	4.3	4.3
3	0	0	-	-
4	2.7	0	0	0
5	5.9	6.2	-	-
6	8.5	9.0	4.1	4.1
7	10.0	0.2	4.1	4.1
8	8.5	9.0	-	-
9	-	-	9.0	9.0
10	-	-	3.9	3.9
11	-	-	-	-
12	-	-	4.3	4.3
13	-	-	9.0	9.0
14	-	-	-	-

Semiconductor pins viewed from top of PC board.

Trans.	Col.	Base	Emi.
Q1	0	0.8	0
Q2	0	0.8	0
Q3	8.7	7.0	6.9

\* Note: Pins on one edge of PC board under the Crystal Filter are not accessible for voltage readings.

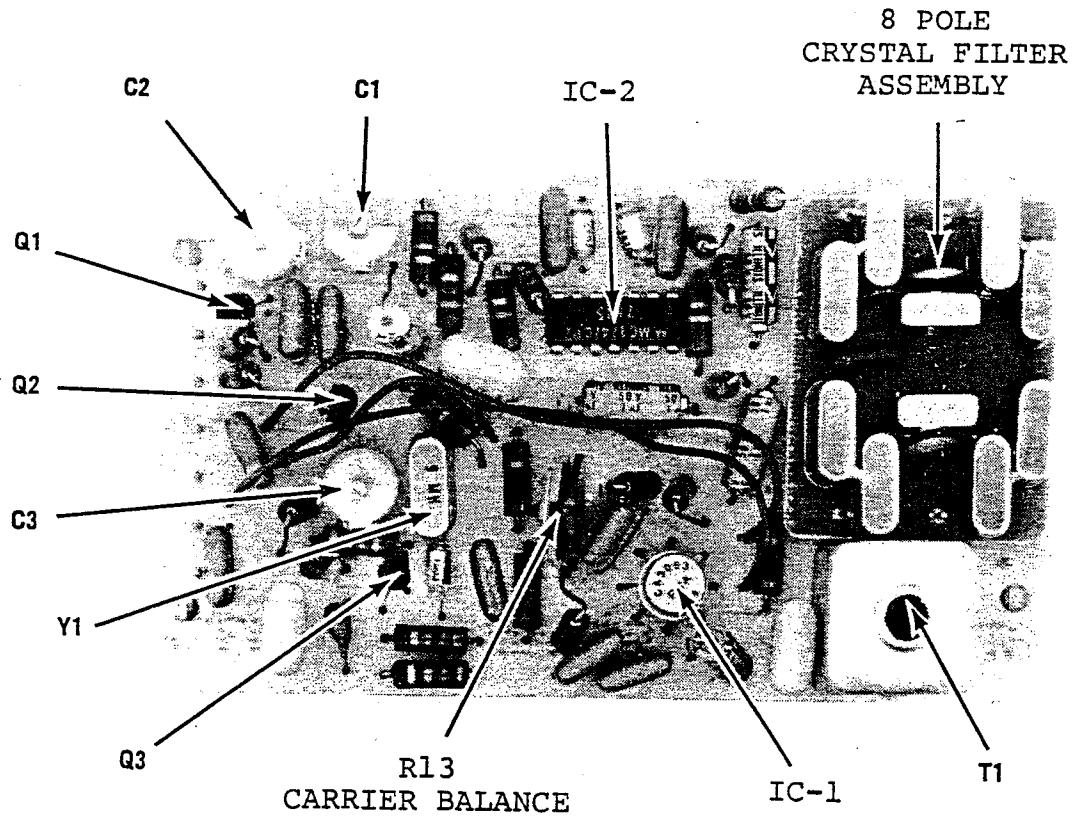
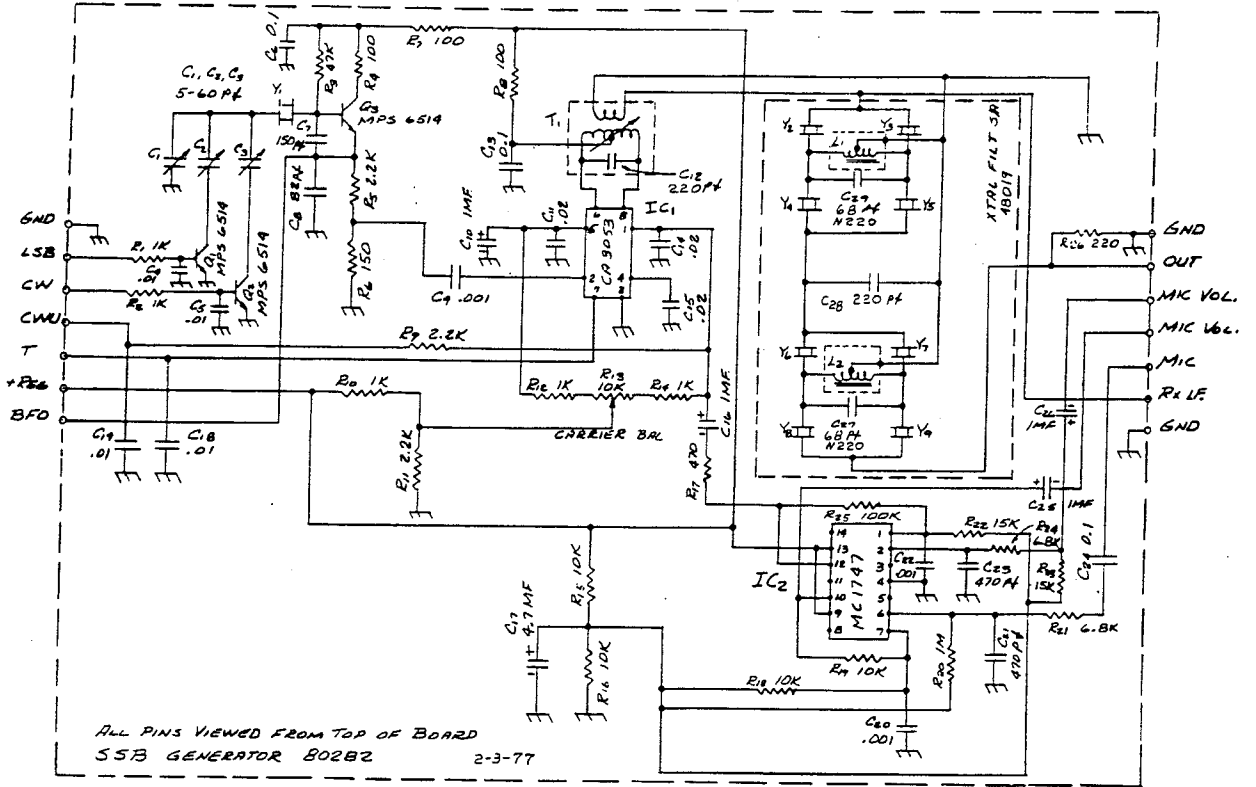

80282 SSB GENERATOR

80291 BANDPASS FILTERS

This plug-in assembly contains five passive filters which are switched into the TX-MIXER output circuit with the BAND switch. They are doubled tuned, over-coupled bandpass units for all but the 3.5 MHz band. A five pole low pass filter is used on this band.

These filters are very broad and require no field alignment. Since they are passive, no voltage measurements are required. However, resistance to chassis on all bands except 3.5 MHz should show zero. On 3.5 kHz, input resistance (right hand set of terminals on schematic) should be infinite due to blocking capacitors on both filter and TX-RX MIXER assemblies. Output terminal resistance is 47 ohms.

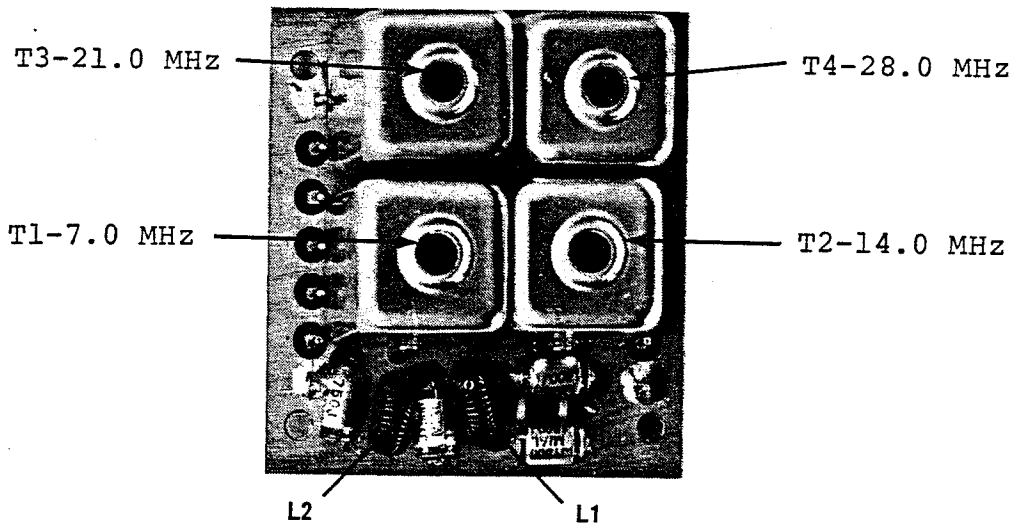
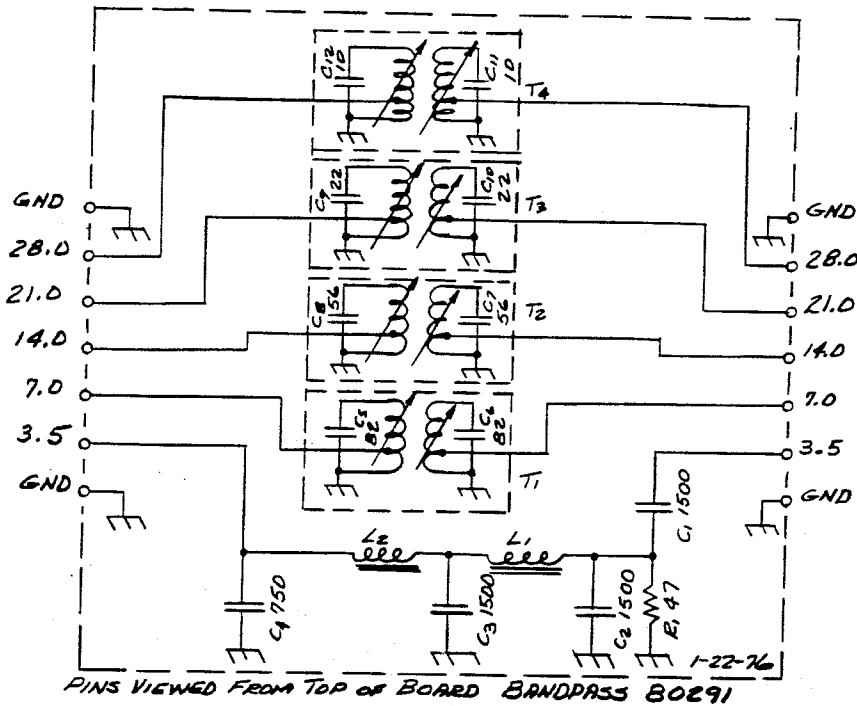

80291 BANDPASS FILTERS

This assembly contains three linear Class A amplifier stages to increase the level of the rf signal from the TX-MIXER and BANDPASS FILTERS to that required to drive the final driver stage. The first two stages, Q3 and Q4, are ALC controlled by transistors Q2 and Q1 in their emitter circuits. The third stage operates at a fixed gain. Bias for the second and third stages is provided whenever the "T" voltage is applied to the T terminal, with diodes D1 and D2 determining the value of bias voltage. The first stage bias is similarly derived from diodes D3 and D4, but the turn-on is delayed a small fraction of a second. Voltage applied to these diodes from terminal tD is delayed from the normal "T" voltage by circuits on the CONTROL BOARD assembly. The delay is a necessary part of the sequential keying circuit that provides clickless CW.

Since all three amplifier stages are broad band designs, no tuning or adjustments are necessary. Switch S4C/S4D, located on the VFO subchassis, inserts a low pass filter on the 7.0 MHz band to reduce higher order mixer products.

Pin Voltage Readings - (SB-N mode, DRIVE fully CCW.)

Pin	Transmit	Receive	Pin	Transmit	Receive
GND	0	0	GND	0	0
tD	4.4	0.2	ALC	4.3	4.3
NC	-	-	IN	0	0
+12	13.0	13.0	GND	0	0
NC	-	-	GND	0	0
OUT	0	0	GND	0	0
GND	0	0	T	10.4	0.2

Semiconductor Voltage Readings (NA=Not Accessable)

Transistor	Collector		Base		Emitter	
	Transmit	Receive	Transmit	Receive	Transmit	Receive
Q1	0.1	0	0.7	0.7	0	0
Q2	0.1	0	0.8	0.7	0	0
Q3	12.0	13.8	NA	NA	NA	NA
Q4	13.8	13.8	NA	NA	NA	NA
Q5	13.8	13.8	1.2	0.2	0.6	0

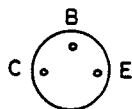

Transistor pins viewed from  
top of PC board.

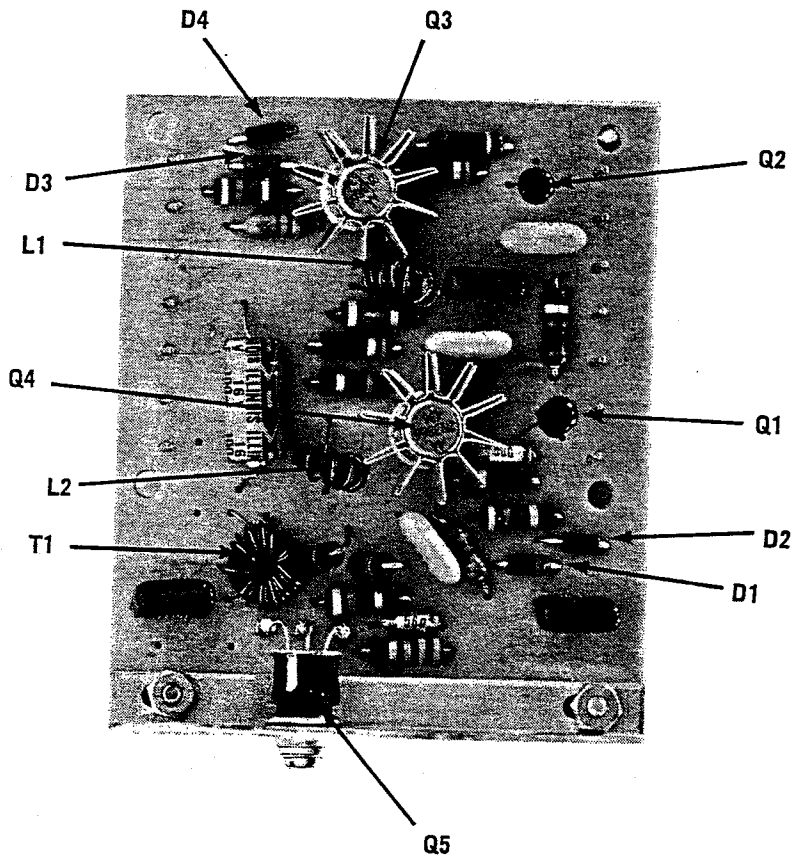
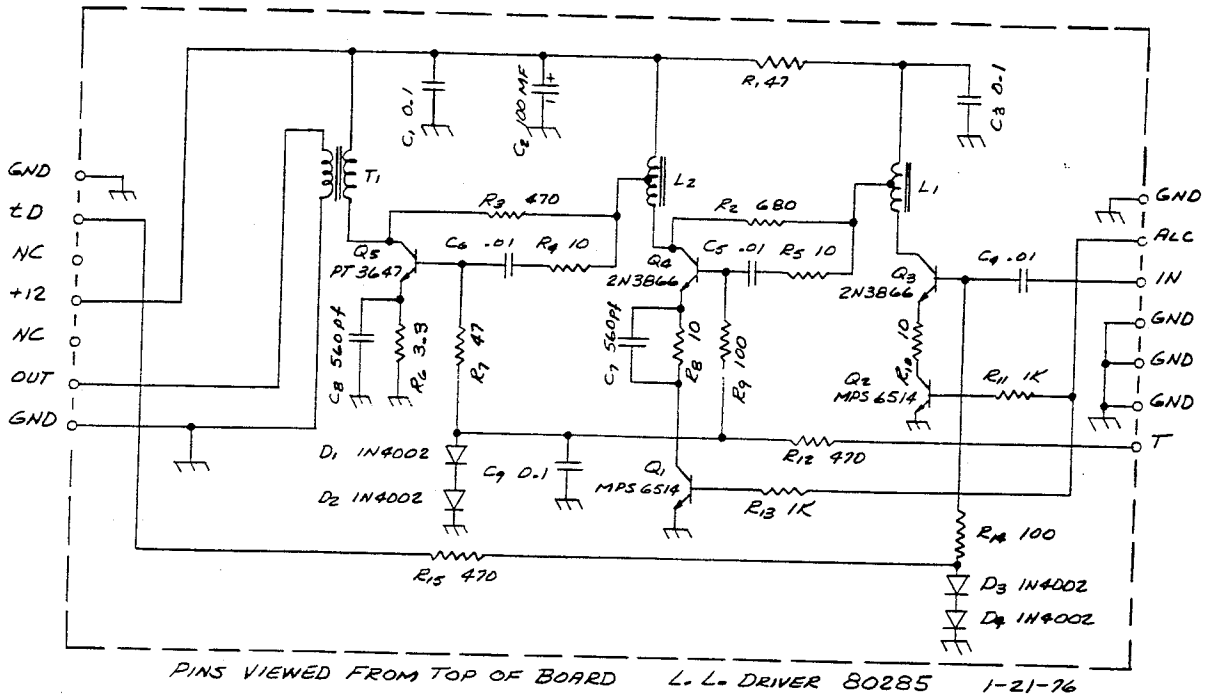

80285 LOW LEVEL DRIVER



## 80276 FINAL AMPLIFIER

The high power rf amplifier and its push-pull drive stage are housed in a metal box which is an integral part of the heat sink assembly. The unit is attached to the back panel with four screws and connections are made by means of two phono connectors for rf input and output and five soldered-on leads for control voltages.

Q1 and Q2 constitute a Class AB linear push-pull driver stage of wide band design. Impedance matching into and out of stage is by means of transformers T1 and T2. Bias is applied whenever "T" voltage is applied to the terminal so marked, and quiescent current in the collector circuit is adjusted to a value of between 4 and 8 mA with potentiometer R11. Access to this control is by means of the small hole in the brass box as shown in Figure 1 of this section. To adjust bias, unsolder the small jumper red wire connecting the second small feed through terminal to the large +12 volt lug. Insert a DC millimeter between the two, set DRIVE control fully CCW and MODE switch to LOCK position. If driver collector current is not between recommended limits, readjust trim-pot (clockwise to increase current) by rotating the trimpot plastic serrated knob through the shield box hold with the aid of a small awl type probe.

Power amplifier transistors Q3 and Q4 are also in a Class AB push-pull arrangement. Bias is applied to the bases in a shunt feed system through L2 and L3. Bias is fed to this stage from a regulated and controlled supply on the OT-TR assembly. Quiescent current for the finals is adjusted as outlined in the section on the OT-TR assembly.

Bias for both stages are temperature compensated to maintain a relatively constant operating point by mounting the bias diodes in direct contact with the heat sink. D1 controls the driver stage and D2 the output stage.

Since all transistors are inaccessible in the shield can, no voltage measurements can be made at their terminals. However, voltages going to the feed-through terminals can be checked to the following values:

(SB-N mode, Drive fully CCW.)

Terminal	Wire Color	Transmit	Receive
T	Yellow	10.4	0.2
+12 DRIVER	#24 Red	13.8	13.8
+12 FINAL	#14 Red	13.8	13.8
BIAS DIODE	White	0.6	0
BIAS	Grey	0.7	0

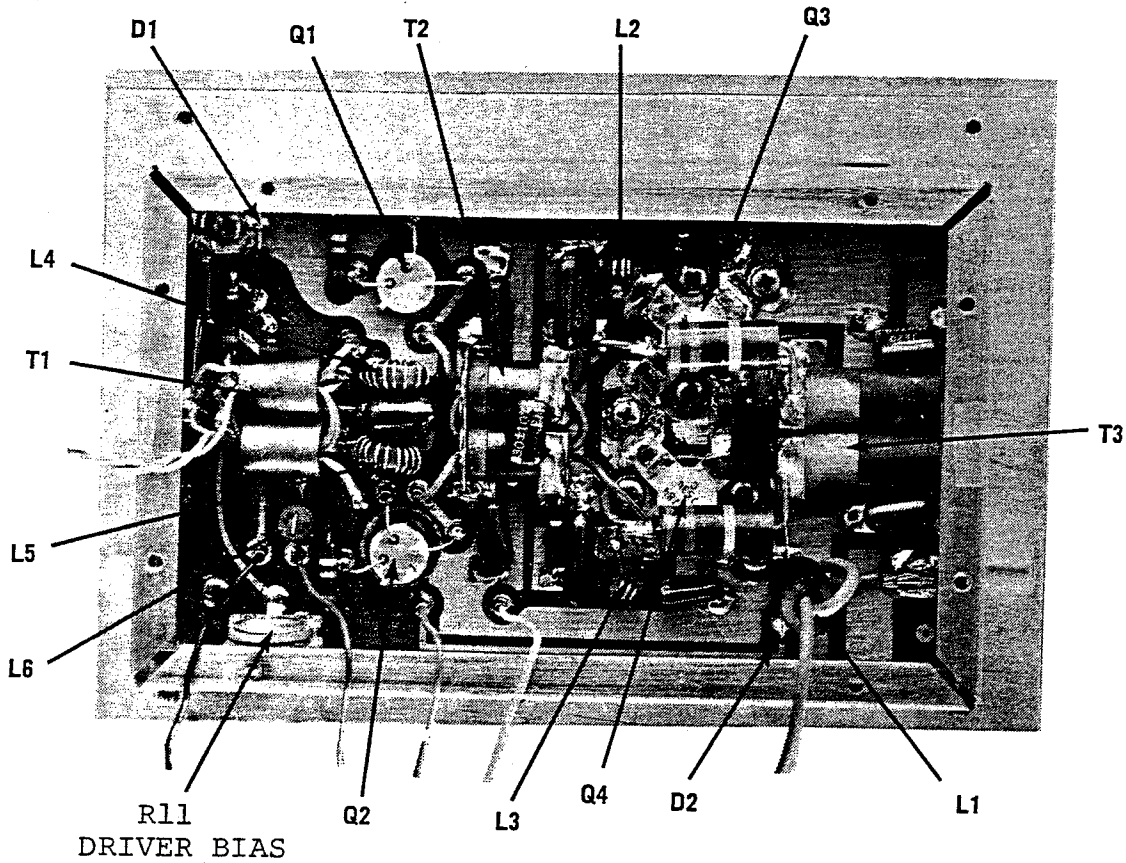
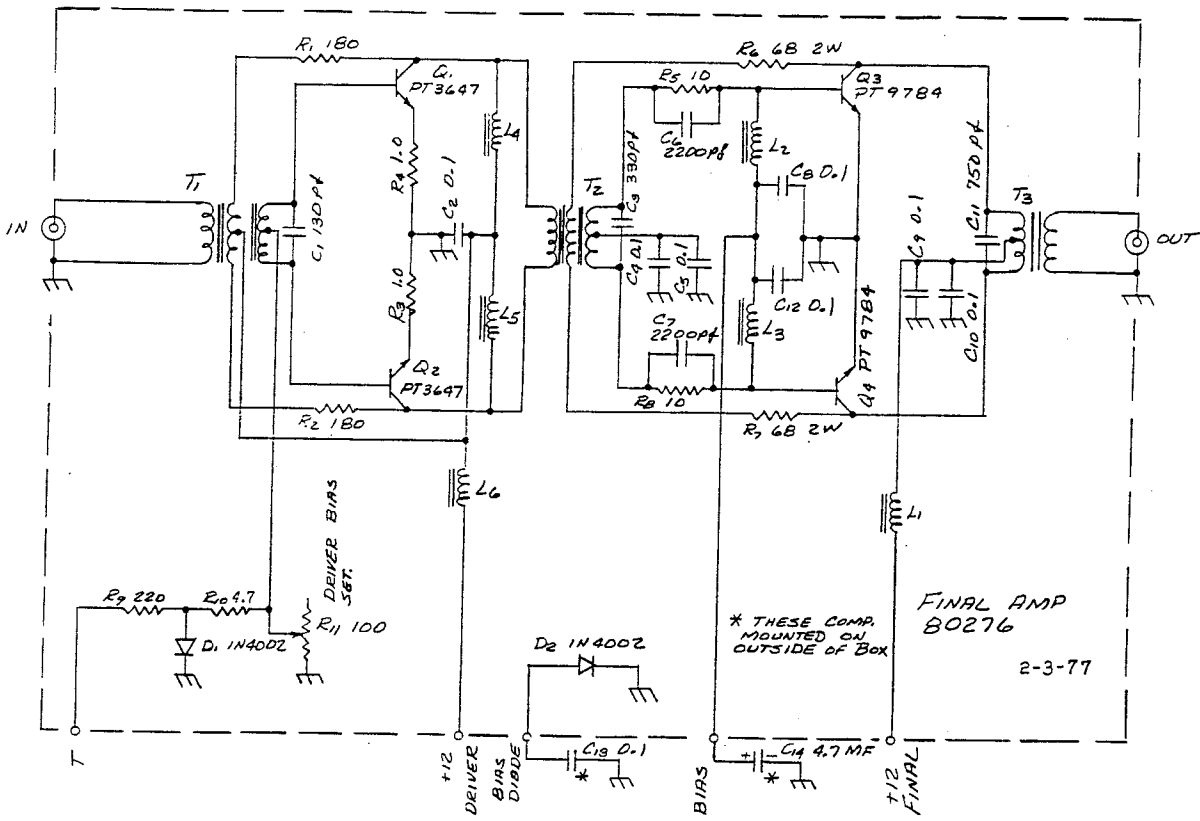

80276 FINAL AMPLIFIER

80284 SWR-ALC

This assembly contains the SWR bridge components, the Automatic Level Control sensing circuit and the receiver antenna relay.

Rf energy on its way to the ANTENNA jack first passes through the primary of transformer T1 in the SWR bridge. The bridge is balanced on the 28.0 MHz band by setting trimmer capacitor C1 so that there is a null on the meter when a 50 ohm resistive dummy load is connected to the ANTENNA jack. Reflected power is sensed through diode D2, filtered to a DC component in C4 and applied to the meter by way of the REV terminal. R11, in series with the meter, is adjusted for a 3 to 1 SWR meter indication when the load is changed to 150 ohms. This adjustment should be made with DRIVE set so that ALC indicator lights.

The forward power is sensed and converted to a DC control voltage through D1 and C3. It is buffered by emitter follower Q1 and then applied to ALC driver stages Q2 and Q3. Output is taken from the ALC pin and applied to the low level rf amplifier assembly. The ALC indicator is connected in the collector circuit of Q2. Both R8, the ALC maximum threshold adjustment, and the panel ALC control setting determine the overall gain of the amplifier. To set R8, set ALC control fully clockwise, power the unit in the LOCK position with a dummy load and with a DC ammeter in the +12 volt lead, advance DRIVE control to where ammeter reads 18 amperes. (R8 should be set to its extreme where ALC light does not light.) Then turn R8 down from this extreme until ALC lamp just starts to light. Check ammeter readings on all other bands, and if reading goes above 18 amperes before ALC lamp lights, reset R8 on this band to 18 ampere meter reading. Final setting of R8 is correct if band indicating highest reading does not exceed 18 amperes.

Relay K1 connects the receiver antenna input circuit to the ANTENNA jack when receiving and to ground when transmitting. It is a fast acting reed relay with SPDT contacts which is energized by the "T" voltage.

Pin Voltage Readings - (SB-N mode, DRIVE fully CCW.)

Pin	Transmit	Receive	Pin	Transmit	Receive
GND	0	0	ALC LITE	13.8	13.8
IN	0	0	ALC	4.3	4.3
OUT	0	0	ALC CONT.	0	0
NC	-	-	+12	13.8	13.8
NC	-	-	REV	0	0
GND	0	0	T	10.4	0.2
NC	-	-	Rx ANT	0	0

Semiconductor Voltage Readings

Transistor	Collector		Base		Emitter	
	Transmit	Receive	Transmit	Receive	Transmit	Receive
Q1	13.8	13.8	0	0	0	0
Q2	11.0	11.0	0	0	0	0
Q3	11.0	11.0	0	0	0	0

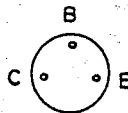

Transistor pins viewed from top of PC board.

The output signal from the final rf amplifier, although linear with regards to its power-in/power-out character, contains harmonic components above desirable levels. The push-pull configuration decreases the even order components to some degree, but does nothing for the odd harmonics. To further decrease evens and odds, the signal is passed through a set of five pole, low pass filters before being radiated. The proper filter is selected by the BAND switch.

The assembly containing the filters and switch is permanently mounted in the rear corner of the chassis, adjacent to the ANTENNA jack. No active components are contained on the assembly and no tuning is required.

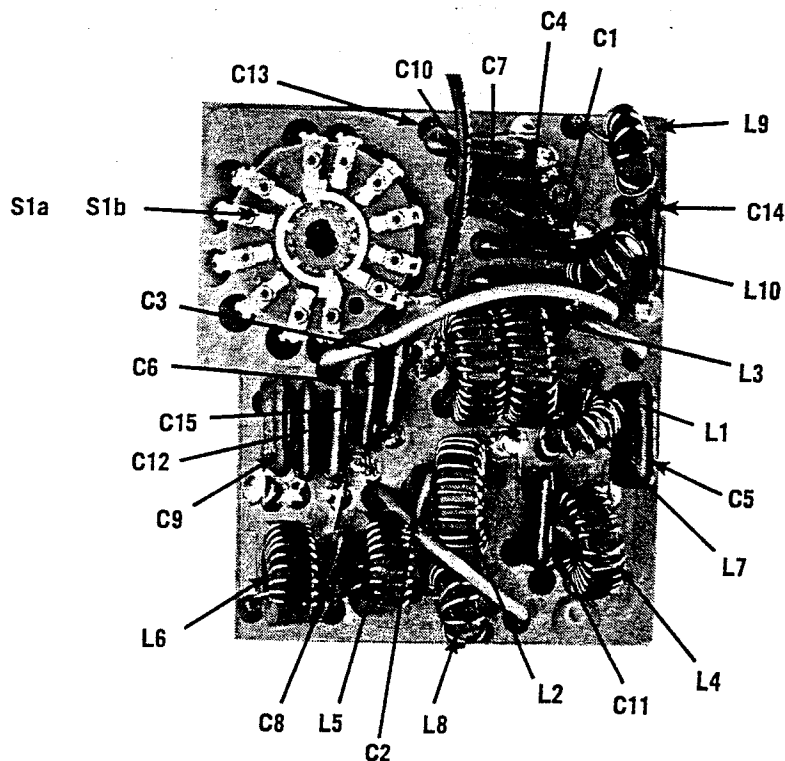
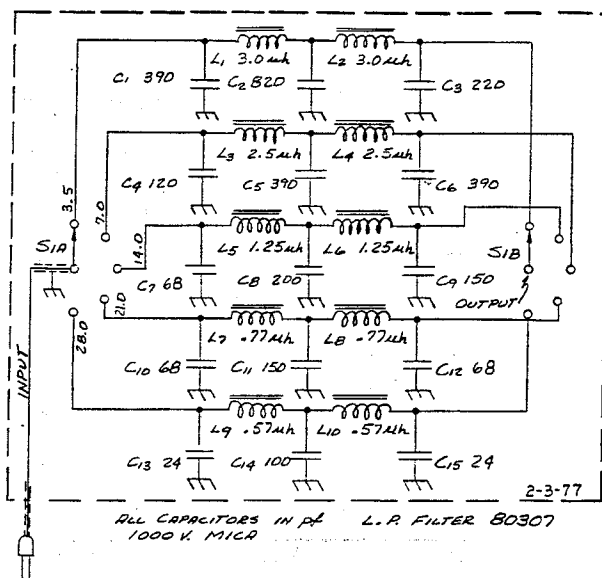

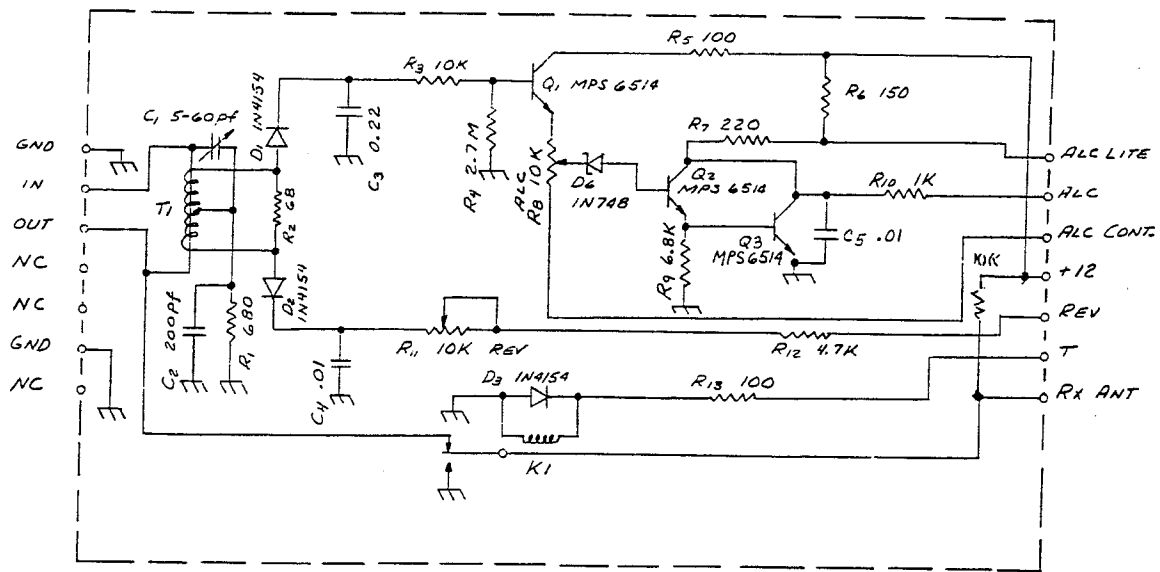

PINS VIEWED FROM TOP OF BOARD SWR-ALC 80284 2-3-77

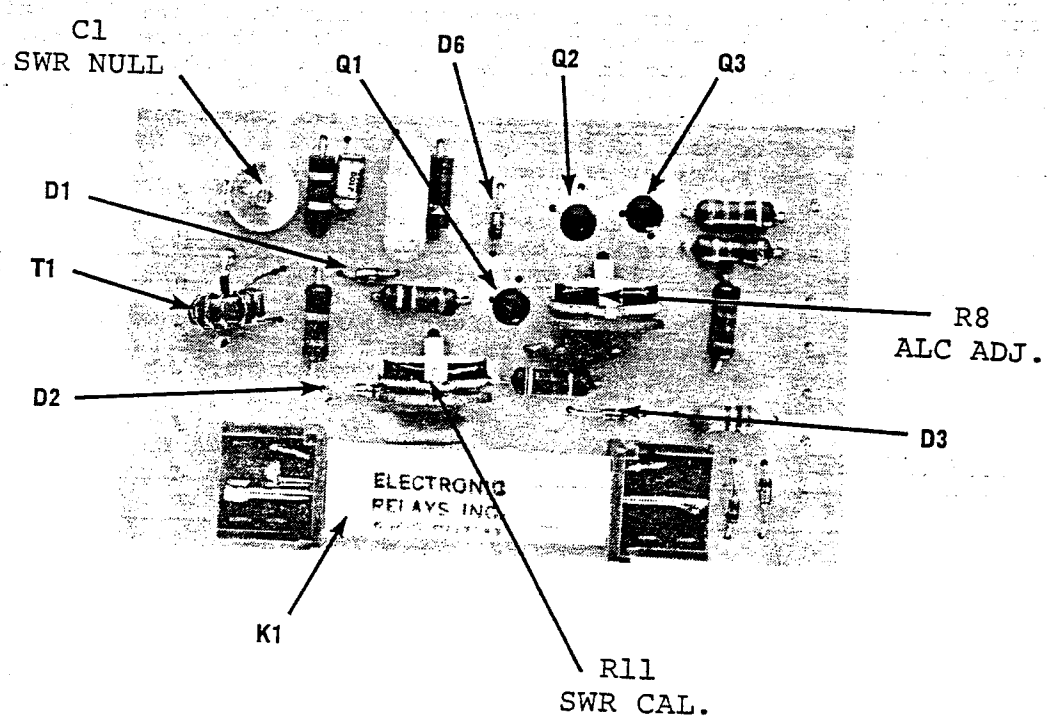

414530

## 80281 OT-TR ASSEMBLY

This assembly contains the final rf amplifier bias regulator, mute relay with adjustable drop-out delay and offset lamp drive.

Bias for the final amplifier is determined by the setting of R9 potentiometer in the integrated circuit regulator IC-1. Temperature correction is achieved with a temperature sensing diode connected mechanically to the final amplifier heat sink and electrically to the IC regulator. Output from the integrated circuit in turn controls power transistor Q1 so that a higher level of current can be regulated. To adjust bias, place a DC ammeter in the +12 volt DC supply lead. Load into a dummy load, set MODE switch to LOCK position and DRIVE control fully counterclockwise. Note current reading and then slowly rotate R9 in the direction that decreases the current reading. After determining which direction decreases current, set control fully in this direction. This will cut off final transistors. Note quiescent current drawn by the remaining transmitter circuits. Then advance R9 so that reading increases by 1/2 ampere--no more. This value should be approximately 1-1/2 to 2 amperes. Too low a bias setting will cause distorted audio in SSB due to the amplifier operating as a Class C amplifier. Too high a quiescent current will increase power dissipation in the output transistors with undue overheating.

The mute relay does not control any internal active functions, but is added for control of external equipment. One set of SPDT contacts are brought out to the unit's rear panel and designated as N.O. and N.C. MUTE jacks. The second set is brought out only as a normally open set and designated EXT. T/R. In both cases, one terminal is connected to chassis ground. If both leads are desired above ground in either or both sets of contacts, as in switching 115 VAC, this can be accomplished by rewiring the plug-in socket. The relay leads on the PC board are isolated from the common ground, but are connected to chassis at the connector socket. Terminal pin C1 is the common terminal of the N.O. and N.C. MUTE jacks and C2 the lead for the EXT. T/R jack. To lift either or both of these from chassis, remove plug-in, unsolder the bare wire from the C1 and/or C2 lug that connects to the chassis lug. Solder an insulated lead to the lug and feed it out of the chassis. CAUTION NOTE: The two phono plugs that are used for these jacks cannot be used if both leads are to be lifted from chassis since one side of these co-ax plugs is inherently a GND lug.

The drop-out delay time is adjusted to a value in accordance with the external equipment requirements with trimpot RL2. In adjusting this potentiometer, do not upset the final bias control setting, R9, on the same assembly.

Transistors Q3 and Q4 turn on the offset tuning OT indicator LED whenever the unit is in the receive mode with the OFFSET on-off knob pushed in. When transmitting, or with the knob pulled out, a control voltage at the OT ON-OFF terminal serves to disable the LED.

Pin Voltage Readings - (SB-N mode, DRIVE fully CCW, OFFSET knob in.)

Pin	Transmit	Receive	Pin	Transmit	Receive
GND	0	0	NO2	0	0
DIODE	0.6	0	NO1	0	0
BIAS	0.7	0	NC1	0	0
NC	-	-	C2	0	0
T	10.4	0.2	C1	0	0
+12	13.8	13.8	OT ON-OFF	10.4	0.2
GND	0	0	OT LITE	13.8	12.0

Semiconductor Voltage Readings

Transistor	Collector		Base		Emitter	
	Transmit	Receive	Transmit	Receive	Transmit	Receive
Q1	13.5	13.8	1.2	0.1	0.6	0
Q2	13.8	13.8	1.3	0	0	0
Q3	0	7.2	0.7	0.2	0	0
Q4	13.4	0.1	.05	0.7	0	0

IC-1

Pin	Transmit	Receive	Pin	Transmit	Receive
1	-	-	8	-	-
2	0.69	0	9	-	-
3	0.67	0	10	1.2	0.1
4	1.0	0	11	13.8	13.8
5	1.0	0	12	10.4	0.2
6	7.2	0	13	0.7	0
7	0	0	14	0.7	0

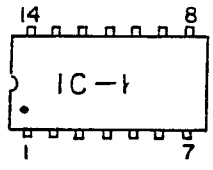

Semiconductor pins viewed from top of PC board.

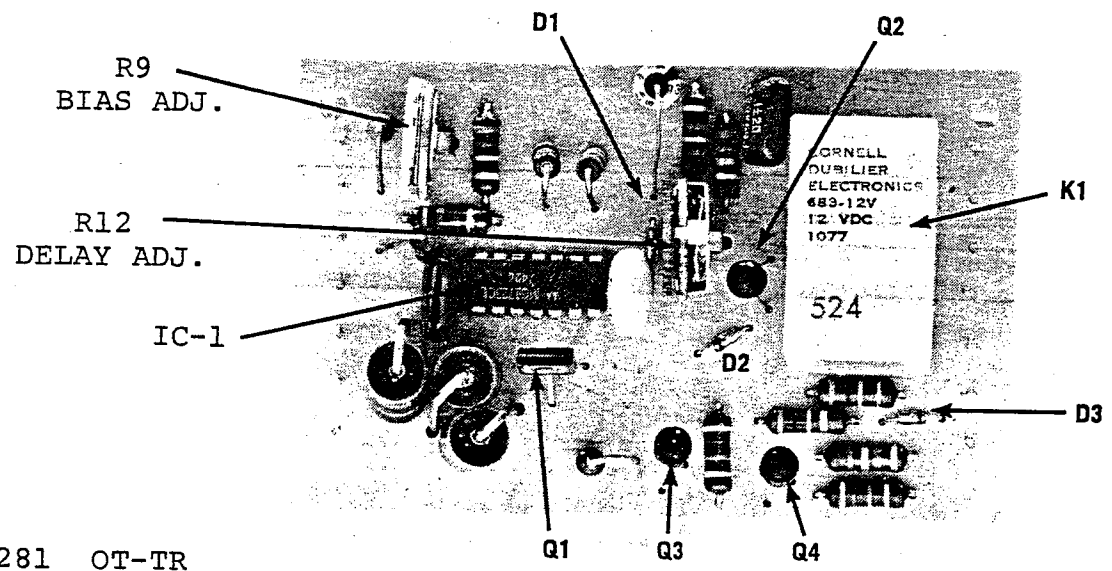
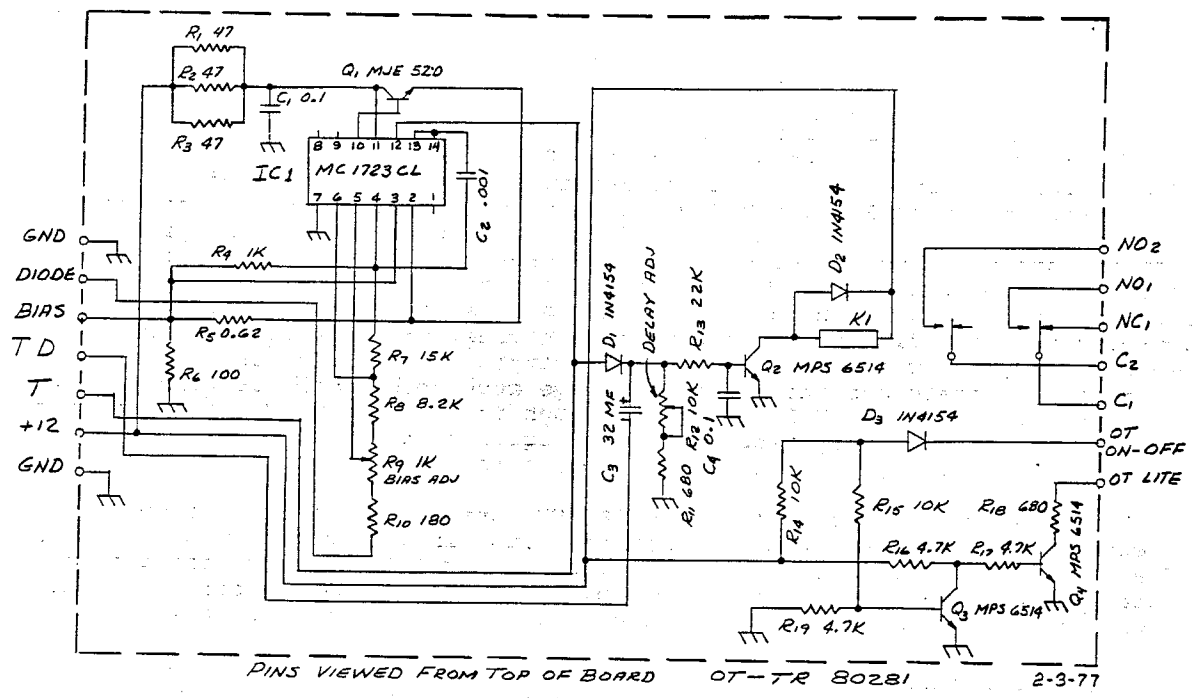

80281 OT-TR

## 80280 CONTROL BOARD

This assembly contains a set of synchronous transistor switches for controlling the "T" and "R" voltages that switch the unit from transmit to receive mode. It also contains an integrated circuit voltage regulator which powers the frequency and voltage sensitive circuits in the VFO, SSB GENERATOR and product detector, and the OFFSET control voltages.

Transistors Q2, Q3 and Q4 constitute the "T" voltage switch which presents operating voltage at the T terminal whenever the T/R terminal is grounded. This occurs whenever the PTT jack is shorted or when the key line is closed. The presence of "T" voltage at the base of Q5 switches off the normally present "R" voltage from switch Q6 and Q7 and terminal R. Whenever "T" voltage is switched on, it is delayed by R8, C2 and R7 and applied to Q1, which momentarily delays the arrival of the "T" voltage at the tD terminal. This delay is necessary for sequential keying in CW which eliminates key clicks. No adjustments are necessary for these circuits.

Regulated voltage of approximately 8 volts is developed in integrated circuit IC-1 and fed to voltage sensitive circuits. No adjustments are needed in the regulator.

The OFFSET control voltage for the varactor diode in the VFO is derived through steering diode D2 through terminal OT. The amount of control voltage varies between about 3 and 6 volts as determined by the setting of the OFFSET control and resistors R21 and R23 which connect in series with the control. Transistor Q9, which is effectively in shunt with this voltage and ground is in an off state and has no effect on the offset voltage when receiving and with the OFFSET knob pushed in. When transmitting, or with the knob pulled out, Q9 is turned on, thereby shunting the voltage at its collector to ground. This back-biases D2 and disconnects the voltage divider from the OT terminal. At the same time, Q8, which was previously conducting and back biasing diode D1, goes to an off state and inserts the voltage developed by the setting of R16, in series with resistors R15 and R17, through forward biased D1 to the OT terminal. Trimpot R16 is adjusted to a value equal to the center position voltage of the OFFSET control, in essence the voltage representing no offset.

To adjust R16 properly, turn the OFFSET control to center zero position and engage the circuit by pushing knob in. Tune in a fairly strong CW signal and adjust to a suitable beat pitch. Then pull OFFSET knob out and adjust R16 so that same pitch is received. Check by alternately engaging offset circuit and make any adjustment so that received beat pitch does not change.

Pin Voltage Readings - (SB-N mode, DRIVE fully CCW, OFFSET knob pushed in and centered.)

Pin	Transmit	Receive	Pin	Transmit	Receive
GND	0	0	GND	0	0
T/R	0	2.1	OT POT	2.3	4.8
R	0.6	12.8	+ REG	8.0	8.0
+12	13.8	13.8	OT	3.1	3.1
tD	4.4	0.2	OT ON-OFF	10.0	0.2
T	10.4	0.2	OT POT	0	3.5
GND	0	0	OT POT	0	2.4

Semiconductor Voltage Readings

Transistor	Collector		Base		Emitter	
	Transmit	Receive	Transmit	Receive	Transmit	Receive
Q1	4.4	0.2	0	0	0	0
Q2	12.5	0.1	0	0.7	0	0
Q3	0	0	12.5	0.1	10.4	0.2
Q4	13.8	13.8	12.5	0.1	11.9	0.2
Q5	.05	13.6	0.7	0.2	0	0
Q6	0	0	.05	13.6	0.6	12.8
Q7	13.8	13.8	.05	13.6	0.6	13.0
Q8	3.5	0.1	0	0.6	0	0
Q9	0	3.5	0.7	0.1	0	0



IC-1

Pin	Receive	Pin	Receive
1	-	8	-
2	8.2	9	-
3	8.0	10	8.2
4	7.0	11	13.8
5	7.0	12	13.8
6	7.0	13	9.2
7	0	14	-

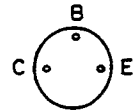
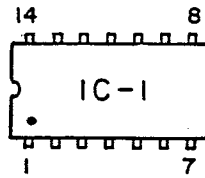

Semiconductor pins viewed from top of PC board.

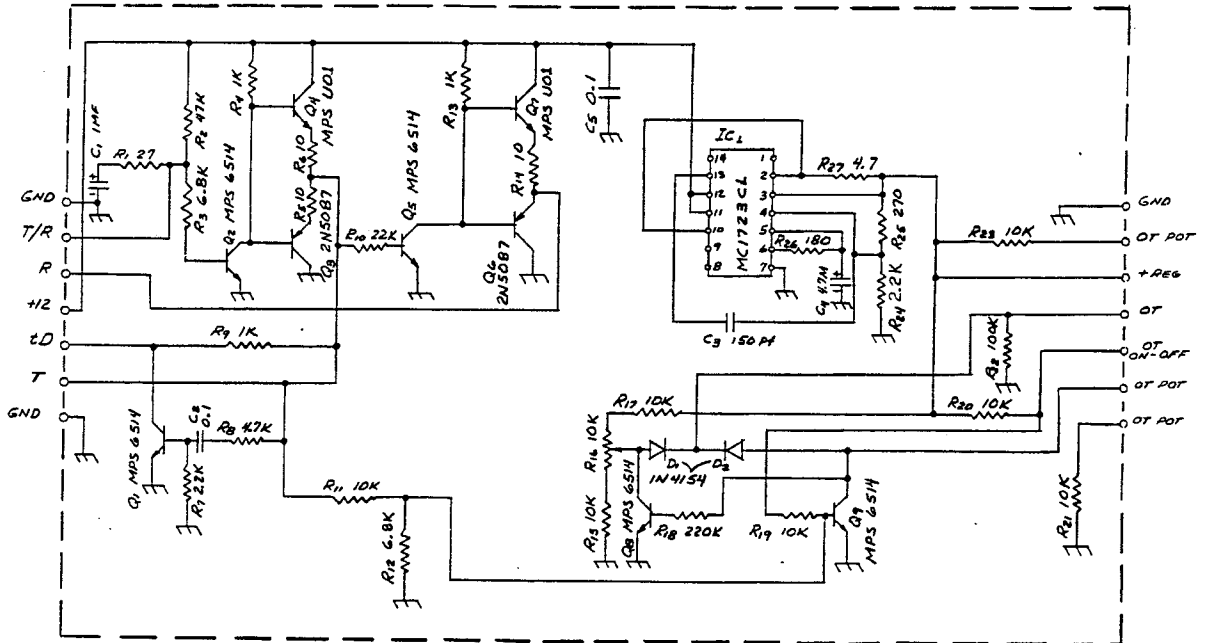

PINS VIEWED FROM TOP OF BOARD

CONTROL BOARD 80280

2-3-77

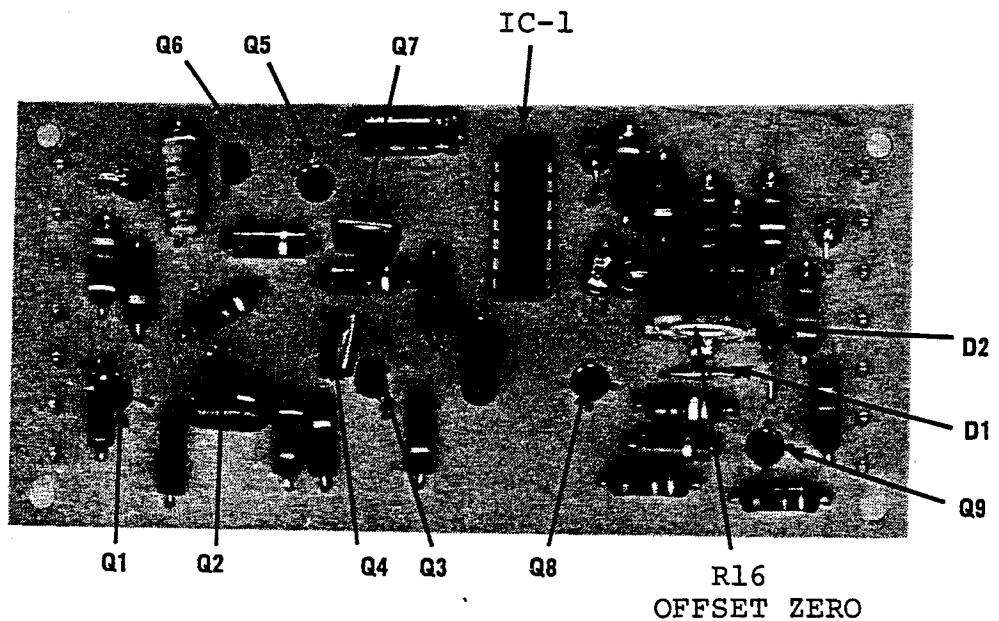

80280 CONTROL BOARD

Ten-Tec, Inc.  
1185 Dolly Parton Parkway  
Sevierville, TN 37862  
Repair Service: (865) 428-0364

#### LIMITED WARRANTY AND SERVICE POLICY, U.S.A. AND CANADA

Ten-Tec, Inc., warrants this product to be free from defects in material and workmanship for a period of one (1) year from the date of purchase, under these conditions:

1. **THIS WARRANTY APPLIES ONLY TO THE ORIGINAL OWNER.** It is important that the warranty registration card be sent to us promptly.
2. **READ THE MANUAL THOROUGHLY.** This warranty does not cover damage resulting from improper operation. Developing a thorough understanding of this equipment is your responsibility.
3. **IF TROUBLE DEVELOPS** we recommend you contact our customer service group direct at the address or phone number shown above. It has been our experience that factory direct service is expeditious and usually results in less down-time on the equipment. Some overseas dealers do offer warranty service and, of course, have our complete support.
4. **EQUIPMENT RETURNED TO THE FACTORY** must be properly packaged, preferably in the original shipping carton(s). You pay the freight to us and we prepay surface freight back to you. Canadian customers must have proper customs documentation sent with incoming repair equipment. Duties or fees charged due to improper documenting are the responsibility of the owner of the equipment.
5. **EXCLUSIONS.** This warranty does not cover damage resulting from misuse, lightning, excess voltages, polarity errors or damage resulting from modifications not recommended or approved by Ten-Tec. In the event of transportation damage, a claim must be filed with the carrier. Under no circumstances is Ten-Tec liable for consequential damages to persons or property caused by the use of this equipment.
6. **TEN-TEC RESERVES** the right to make design changes without any obligation to modify equipment previously manufactured, or to notify owners of changes to existing equipment.
7. **THIS WARRANTY** is given in lieu of any other warranty, expressed or implied.

#### SERVICE OUTSIDE OF THE U.S.A. OR CANADA

Many of our international dealers provide warranty service on the equipment they sell. Many of them also provide out of warranty service on all equipment whether they sold it or not. If your dealer does not provide service or is not conveniently located, follow the procedure outlined above. Equipment returned to us will be given the same attention as domestic customers but roundtrip freight expense, customs and broker fees will be paid by you.

Part no. 74244