

DIGITAL DISPLAY UNIT

YC-7B

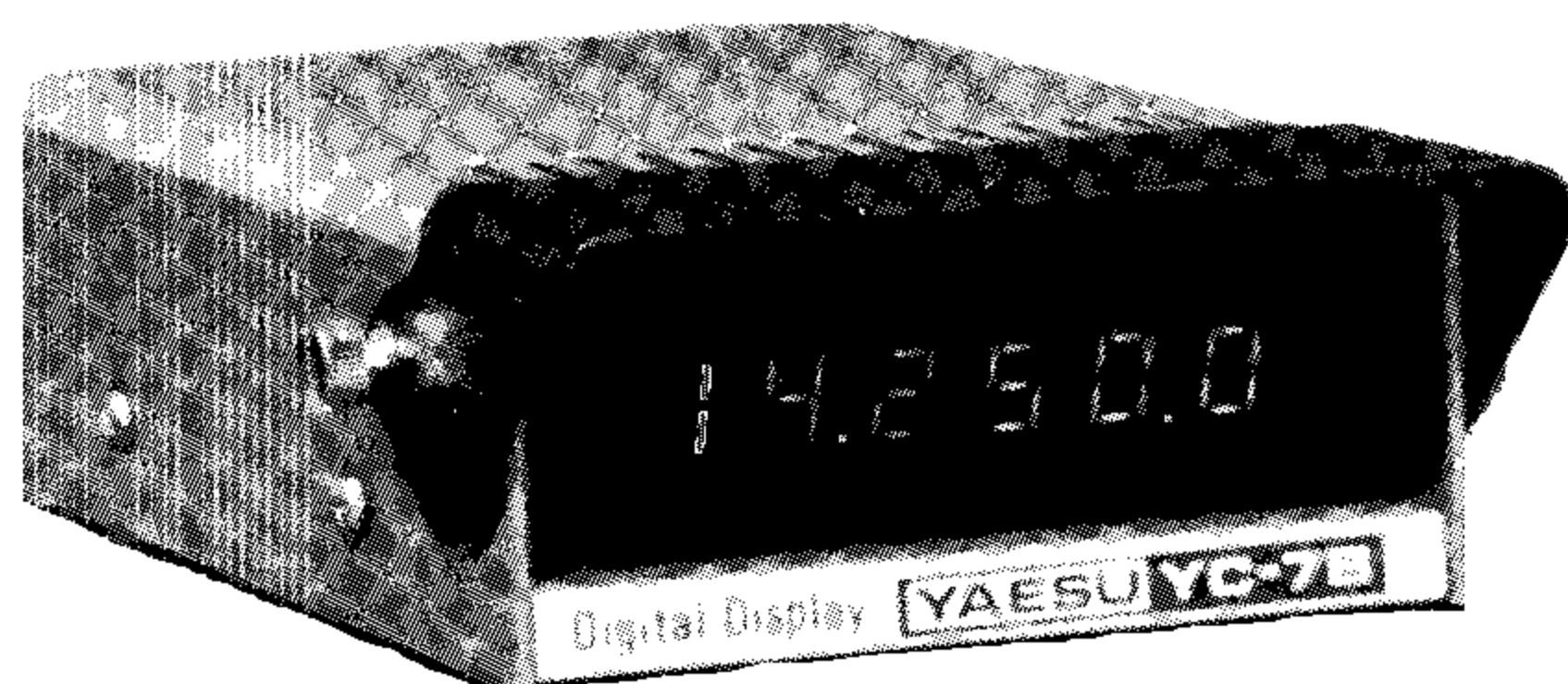

GENERAL

The YC-7B digital display unit provides remote digital display of the operating frequency, when used with the FT-7B transceiver. Interconnections to the FT-7B may be completed in seconds.

INSTALLATION NOTES

Connect the connection cable from the YC-7B to the EXT DIS jack on the rear of the FT-7B.

The YC-7B may be mounted in any place where convenient, subject to the following precautions. Extremely hot sunshine may cause an erratic display, and may cause part failure. Do not store the YC-7B in the hot sunshine for any period of time. The display may become erratic above 75° C, and parts may fail at any temperature above 120°.

When leaving your automobile on a sunny day, place a magazine or other protective cover over the YC-7B, to protect it from extremes of temperature.

High SWR on the antenna feedline may cause RF currents to cause an erratic display. If your antenna SWR is below 2:1, there should be no difficulty encountered. Low SWR is also essential for proper operation of your FT-7B, of course.

SPECIFICATIONS: YC-7B

Display resolution: To 100 Hz (6 digits)

Counter fundamental frequency: 655.36 MHz

Gate time: 0.1 sec.

Operating temperature: 0°C - 40°C

Power connections: From FT-7B

Case size: 93 (W) x 40 (H) x 135 (D) mm

Weight: 360 grams

SEMICONDUCTOR COMPLEMENT

FET

2SK19GR 1
3SK51-03 1

Transistors

2SA733 1
2SC372Y 1
2SC785R 1
2SC945 1
MPS3640 1

IC

MC10116 1
MC14050 1
MSM561RS 6
MSM5564 1
SN74S00N 1
SN74LS00N 1
SN74LS04N 1
SN74196N 1
SN74LS196N 6
μPC14305 1
μPC14308 1
μA78L08 1

Diodes

1S1555 21

Display

5082-7740 6

ACCESSORIES

CONNECTION CABLE (1)
(Integral part of YC-7B)

INSTALLATION TAPE

Remove backing, install
1 piece to YC-7B, 1 piece
in desired position in car
for display.

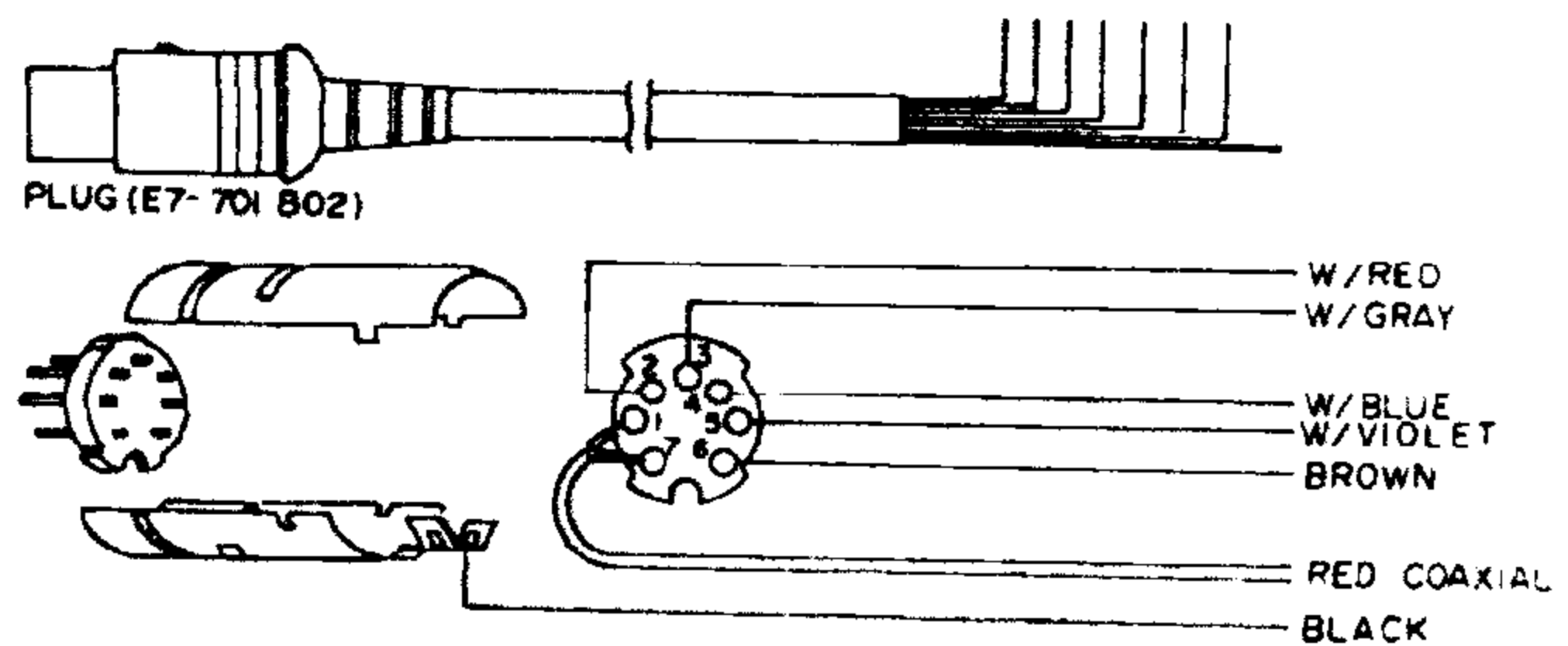

CIRCUIT DESCRIPTION

The FT-7B local signal is fed from the EXT DIS jack on the rear of the transceiver to the YC-7B.

The local signal is amplified by Q101 (3SK51-03) and fed to buffer Q102 (2SC785). The signal from the emitter then splits. The 80 meter signal at 5.5-5.0 MHz is fed to mixer Q105 (SN76514N), where it is mixed with a heterodyne signal generated by Q104 (2SC372Y) at 18 MHz. The resulting 12.5-13.0 MHz signal is fed to Q103 (2SK19GR, a buffer amplifier. In the 80 meter control line from the FT-7B, a HIGH level will cause Q117 (2SC945) to conduct, and a LOW level will cause Q118 (2SA733) to conduct, routing the signals appropriately. Diode switches D101 and D102 (1S1555) make the switching operations for feeding Q103.

The output from Q103 is then fed to a waveshaper, Q106 (MC10116). Q107 (MPS3540) acts as an interface between Q106 and the TTL circuitry. The signal is then fed to the counter gate, Q113 (SN74S00N).

The clock pulses are generated by Q2305 (MSM5564), which produces a 655.36 MHz signal. The signal is divided by a factor of 2^{17} producing a 5 Hz signal which is fed to the counter gate.

The pulses which pass through the gate are fed to decade counter Q201 (SN74196N), which counts 10 Hz digits. In turn, Q202-Q207 (SN74196N) count 100 Hz, 1 kHz, 10 kHz, 100 kHz, 1 MHz, and 10 MHz digits. The BCD output signal from Q202-Q207 is fed through drivers Q208-Q213 (MSM561) to the display digits, DS301-DS306 (5082-7740), which display the operating frequency.

The parameters for presetting the counter are shown in Table 1. As an example, let us say we are operating on 14.000 MHz, USB mode. The premix local frequency is 23.001.5 MHz, and the USB preset frequency is 90.998.5. Adding these numbers yields 114.000.0; the first figure is blanked (overflow), and the rest of the digits are displayed as the operating frequency. The presetting is accomplished by diode matrix D201-D213 (1S1555), AND gate Q111 (MC14050), and NAND gates Q112 (SN74LS00N) and Q113 (SN74S00N).

The power for the counter is taken from the FT-7B 13.5 volt line. Q108 (78L08) regulates the supply voltage at 8 volts for the counter. The 13.5 volt line voltage is first stabilized at 8 volts by Q109 (uPC14308), and then at 5 volts by Q110 (uPC14305), for the TTL components.

MAINTENANCE AND ALIGNMENT

The YC-7B normally requires no alignment. Erratic operation, if not caused by high SWR, may be assumed to be caused by part failure.

For setting the 655.36 kHz fundamental signal, connect a frequency counter to pin 2 of Q116, and align TC101 for a reading of exactly 655.36 kHz. If no frequency counter is available, the marker signal of the FT-7B may be used. Zero beat against the marker signal, and adjust TC101 for a zero setting on the band edge.

On the 80 meter band, should a small discrepancy exist, the 18.000 MHz heterodyne signal may require adjustment. Connect a frequency counter to the emitter of Q104, and adjust TC102 for a reading of exactly 18.000 MHz. The marker signal may be used, as above, at a frequency of 3.500 MHz. Tune for exactly a zero beat.

If an anomaly appears on only one band, on 40-10 meters, please adjust the premix local frequency in the FT-7B, as outlined in the instruction manual.

LSB	91.001.5
USB	90.998.5
CW.AM(80m)	90.999.3
CW.AM(40-10m)	91.000.7

Preset
Number

Table 1

	Nominal Premix Local Frequency	LSB	USB	CW-AM
80m	12.5-13.0	12.498.5-12.998.5	12.501.5-13.001.5	12.500.7-13.000.7
40m	16.0-16.5	15.998.5-16.498.5	16.001.5-16.501.5	15.999.3-16.499.3
20m	23.0-23.5	22.998.5-23.498.5	23.001.5-23.501.5	22.999.3-23.499.3
15m	30.0-30.5	29.998.5-30.498.5	30.001.5-30.501.5	29.999.3-30.499.3
10mA	37.0-37.5	36.998.5-37.498.5	37.001.5-37.501.5	36.999.3-37.499.3
10mB	37.5-38.0	37.498.5-37.998.5	37.501.5-38.001.5	37.499.3-37.999.3
10mC	38.0-38.5	37.998.5-38.498.5	38.001.5-38.501.5	37.999.3-38.499.3
10mD	38.5-39.0	38.498.5-38.998.5	38.501.5-39.001.5	38.499.3-38.999.3

Table 2

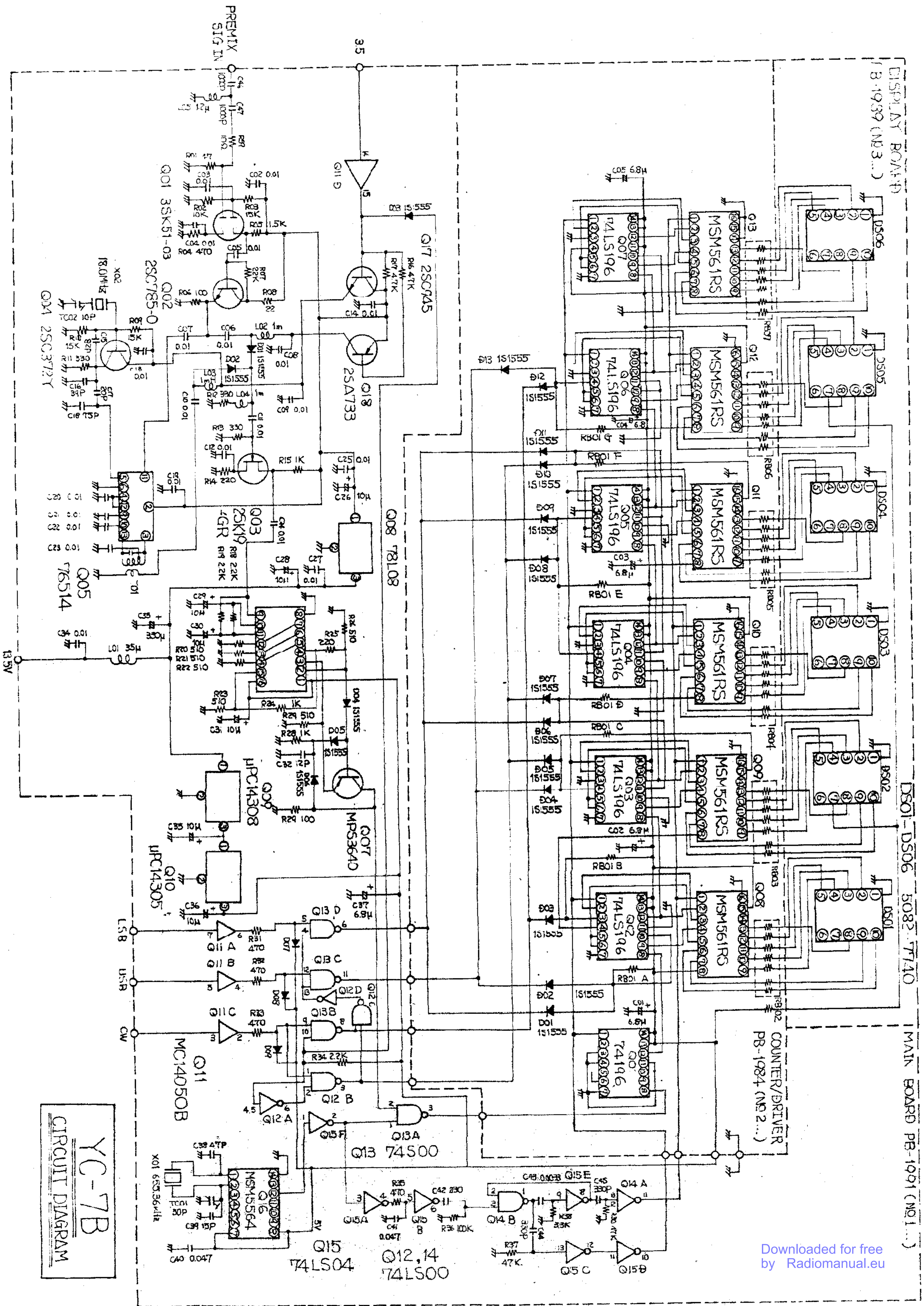

YC-7B
CIRCUIT DIAGRAM