

**INSTRUCTION
MANUAL
YR-901**

YAESU MUSEN CO., LTD.

TOKYO JAPAN

YAESU

YR-901 CW/RTTY READER



INTRODUCTION

The YR-901 is a microprocessor-controlled code processing instrument. Equipped for display on a monitor television or USA-standard home television, the YR-901 will translate Morse and teletype signals for display, as well as translating ASCII and teletype machine output into Morse or teletype output signals. The Morse reader will also display Japanese-language Kana code—in Japanese characters!

The video output is a precision 5 x 7 dot display character, for sharp and easy viewing. One page consists of as many as 512 characters, and the memory feature will hold one page of copy while the Central Processing Unit (CPU) continues monitoring. Both negative and positive video displays may be selected.

Active audio input bandpass filters assure optimum signal-to-noise ratio. For FSK, all of the common shifts may be used, and the CW input frequency may be varied between 600 Hz and 1 kHz. FSK baud rates of 45.5 and 50 baud are standard, with an easy modification allowing operation on 57 and 75 baud.

Operation is possible without modification using type ASR32, ASR33, and ASCII keyboards. For use of an ASR28 or similar machine, the optional Local Loop (60 mA) Unit will allow operation. Installation is straightforward.

We recommend that you read this manual in its entirety, so that you will better understand the many outstanding features of the YR-901 CW/RTTY Reader—another breakthrough from the hams at Yaesu.

SPECIFICATIONS

GENERAL

Character composition (video):

5 x 7 dot character

Page dimensions:

32 characters x 16 lines

Page capacity:

512 characters

Video display:

Positive and negative display, selectable

Display modes:

Monitor TV, home TV (USA channels 3/4), teletype printer. Video modulator optional.**

Output:

Video out to monitor TV, RF out to home TV (USA standard 525 line) (option)**

Speaker:

4 ohms at 3 watts, parallel headphone jack

Teletype machine current capability:

20 mA current loop (60 mA current loop option)

Power requirements:

100/110/117/200/220/234 VAC, 50/60 Hz

Current consumption:

40 VA

Case size:

208 (H) x 154 (W) x 323 (D) mm

Weight:

Approx. 6 kg

** Video modulator not available in U.S.A.

CW MONITOR

Display modes:

Letters, Japanese Katakana characters, numbers, punctuation (. , : ; ? - " ' ()), operating symbols (BT, HH, AS, VA, AR, KA)

Input error tolerance (editing feature):

Between 1/3 and 3 times sampled values

Input frequency:

800 Hz (adjustable between 600–1000 Hz)

Input level:

50 mV RMS @ 4 ohms, with S/N 6 dB minimum

Transmit capability:

External electronic keyer, teletype machine, ASCII keyboard

Keying voltage/current:

+12V or –25V key up, 50 mA key down

RTTY MONITOR

Baud rates:

45.5, 50 (standard), 57, 75 (with modification)

Shift frequencies:

170 Hz, 425 Hz, 850 Hz

FSK input frequencies:

2125 Hz + shift

Compatible machines:

ASR-32, ASR-33 teletype, ASCII keyboard

Input limiter:

Installed

Antispace:

ON/OFF selectable

Autostart:

ON/OFF selectable

ACCESSORIES

The following accessories are included with your YR-901:

3 pin phone plugs	2 ea.
6 pin DIN plug	1 ea.
7 pin DIN plug	1 ea.
RCA pin plugs	5 ea.

Note: When using type ASR33 or ASCII keyboards, a jumper wire should be connected between pins 2 and 3 of the 6 pin DIN plug, which should then be inserted into its rear apron jack. When using an ASR32 type machine, this is not needed. When not using any keyboard (RX monitoring only), please insert this plug with the jumper installed.

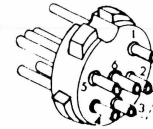
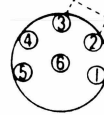

Plug for J₁₀₅

1. F/L CONTROL (Not used)
2. TTY OUTPUT +
3. TTY OUTPUT -
4. TTY INPUT -
5. TTY INPUT +

AVAILABLE OPTIONS

60 MA LOCAL LOOP UNIT (For ASR28 operation, etc.)

VIDEO MODULATOR

SEMICONDUCTORS

Transistor:		SN7473N	1	μ PD369C	2
2SA733	5	SN74LS73N	4	μ PD472-01	1
2SC945	11	SN74LS74AN	4	μ PD2101ALC-4	2
2SC2333	1	SN74LS85N	4	μ PD2102ALC-4	7
2SD359	1	SN74LS86N	1	μ PD2316A-054	1
MJE2955	1	SN74LS123N	3	μ PD8080AFC	1
		SN74LS125AN	4	μ PD8212C	1
		SN74LS157N	5	μ PD8251C	1
IC:		SN74LS161N	5		
IR2406	1	SN74LS166N	1	Diode:	
MC3403P	5	SN74175N	2	Silicon 1S1555	14
MC14050BCP	3	SN74S188N-Y1	1	Silicon 1S553	4
NE555V	6	SN74S188N-Y2	1	Silicon 10D1	1
SN74LS00N	4	SN74S188N-Y3	1	Silicon 10D10	1
SN74LS02N	2	SN74S188N-Y4	1	Silicon S4VB10	1
SN74LS04N	6	SN74S188N-Y5	1	Zener RD6.8EB	1
SN74LS08N	3	SN74LS283N	1	Zener WZ050	1
SN74LS10N	2	μ PB8224	1	LED GL112-R3	1
SN74LS27N	1	μ PB8228C	1	LED LN222RP	4
SN74LS30N	2	μ PC14305	1		
SN74LS32N	3	μ PC14312	1		
SN74LS51N	2				

Specifications subject to change without notice or obligation

FRONT PANEL CONTROLS AND SWITCHES

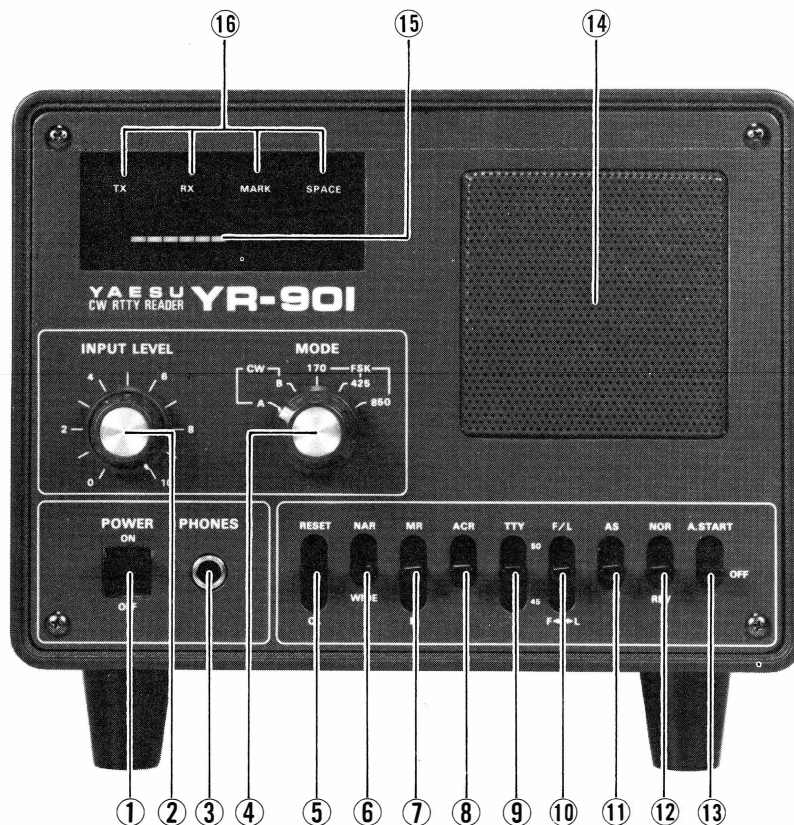

(1) POWER

This is the main power on/off switch for the YR-901.

(2) INPUT LEVEL

This control sets the input audio level from the transceiver or receiver.

(3) PHONES

When it is desired to use headphones, with the YR-901 in operation, please plug in your headphones to the YR-901 PHONES jack. Connection to the FT-901DM headphone jack will cut off the audio input to the YR-901, rendering it inoperable.

(4) MODE

The MODE switch selects the operating mode for the YR-901.

CW A Display will be of the Japanese Katakana code, used extensively by Japanese amateurs on 40, 80, and 160 meters.

CW B Display will be of standard International Morse code, using Roman letters.

FSK 170 . . The YR-901 will now read frequency-shift keyed transmissions with a shift of 170 Hz.

FKS 425 . . This position selects reading of FSK with 425 Hz shift.

FSK 850 . . This position selects reading of FSK with 850 Hz shift.

(5) RESET/CL (Clear)

In the RESET position, the CPU is cleared, and a new sampling cycle will begin. This position should be used when beginning operation, or when returning to a station using a considerably different code speed than that of the previous station.

The CL position is used to clear a page of copy from the screen, while maintaining the CPU sampling status in its present state.

(6) NAR/WIDE

This switch selects one of two input bandpass filters. In the NAR (narrow) position, a filter width of ± 10 Hz is selected. In the WIDE position, a filter bandwidth of ± 50 Hz is selected. The F. ADJ. control allows setting the center frequency of the filters, within the range 600–1000 Hz.

(7) MR/OFF/M

This switch selects the operating mode for the memory system. The M position is a momentary switch position, which stores in memory all characters posted on the TV screen up to the point where the lever is depressed. The reader will continue to list characters after the lever is pressed, though. The MR position is used to recall up to a page of copy. In the MR position, only the memorized copy will be displayed (not any subsequent characters), but the YR-901 will hold in another register all copy that would be displayed, had the MR position not been selected. Upon return to the OFF position, the TV screen returns to normal monitoring.

(8) ACR (Automatic Carriage Return)

This is the ON/OFF switch for the ACR feature. When four consecutive space signals are received, the ACR feature will return the readout to the beginning of a new line.

(9) TTY (50/45)

This switch selects a 50 baud or 45 baud rate for TTY operation. With the TTY switch in the OFF position, TTY operation is not possible.

(10) F/L

This is the figure/letter shift switch for ASCII use.

(11) AS (Antispace)

This switch activates the Antispace feature.

(12) NOR/REV

Normally, the MARK signal for teletype is at 2125 Hz, and the SPACE signal is at 2295 Hz (for 170 Hz shift). However, the mixing scheme for some receivers causes these relations to be reversed. In this case, the NOR/REV switch will allow a reversing of the input MARK/SPACE relationship, to permit proper operation.

(13) A. START (Auto Start)

The autostart feature will respond to the first SPACE signal received, supplying 117 volts AC to the MOTOR AC OUT jack on the rear apron, automatically starting the motor of your teletype machine.

(14) SPEAKER

The audio output from the receiver is fed to the YR-901 speaker.

(15) Indicator LEDs

These LEDs display the input level. Refer to the selection on Operation for details of the proper adjustment procedure.

(16) Mode Indicator LEDs

These LEDs light up to signify TX, RX, MARK, and SPACE conditions.

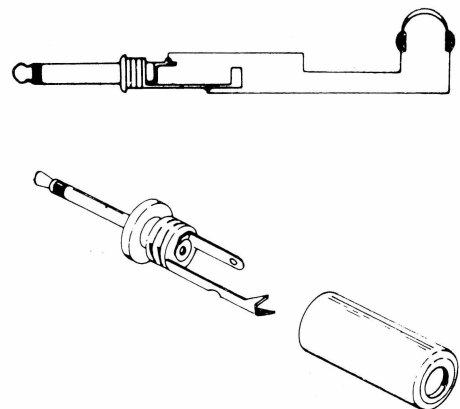
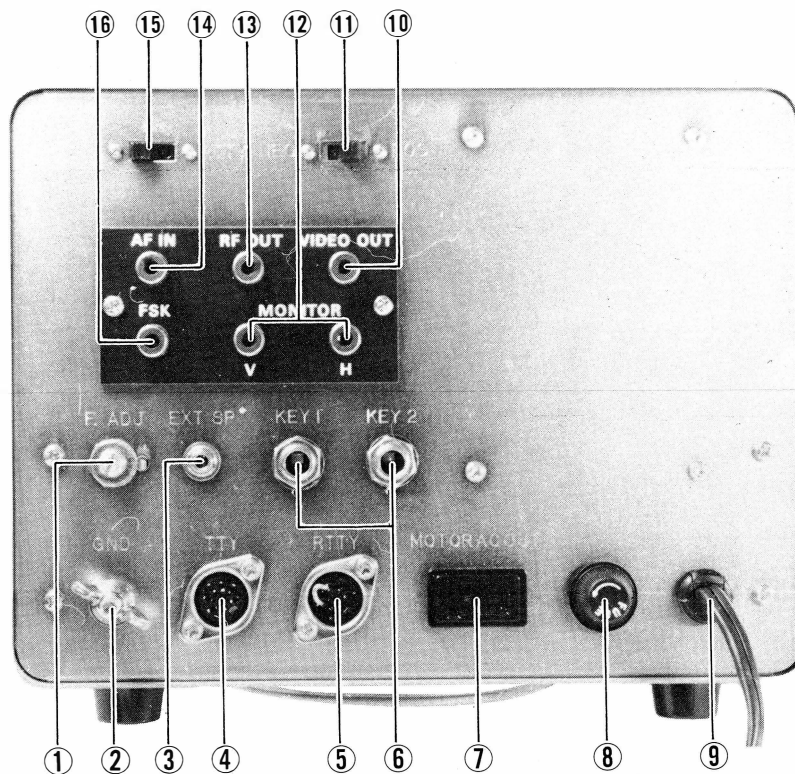

Fig. 1 Headphone Plug

REAR PANEL CONTROLS, SWITCHES AND CONNECTIONS



(1) F. ADJ

This control sets the center frequency for the input bandpass filter for the CW monitor. The adjustment range is 600–1000 Hz.

(2) GND

The YR-901 should be connected to a good earth ground at this point. Use a heavy, braided wire not more than 10 feet long for connection to your main station ground buss.

(3) EXT SP

An external speaker may be connected at this point. Connection of a plug to this jack will automatically cut off the YR-901 internal speaker. The external speaker (and internal speaker, as well) will be cut off when headphones are used with the YR-901.

(4) TTY

This is a 7 pin DIN connector for connection of your ASCII keyboard. Output level is 5 volts at 20 mA.

(5) RTTY

This is a 6 pin DIN connector for connection of an ASR-32 or similar teletype machine. When using an ASR-32 or similar teletype machine (ASR-28, etc.,

with optional Local Loop Unit), remove the jumper between pins 2 and 3 of the 6-pin plug for this jack. For all other teletype operation, the 6-pin plug (with jumper) must be inserted here.

(6) KEY 1, KEY 2

These jacks are connected in parallel. For normal CW operation, your keyer paddle may be connected to KEY 1, and a patch cord may then be connected between KEY 2 and the FT-901DM KEY jack. When using an ASCII or RTTY input for conversion to Morse, the Morse output may be taken from this jack and fed to the FT-901DM. Don't forget to set the FT-901DM keyer speed to MANUAL under this mode of operation.

(7) MOTOR AC OUT

With the A START switch ON, AC 117 volts (or your local line voltage) will appear at this jack when the first SPACE signal of an RTTY transmission is received. When the A START switch is OFF, the 117 VAC will appear at all times at this jack.

(8) FUSE

For all operating voltages, a 1 ampere fuse should be connected here. When replacing fuses, be

absolutely certain to use a fuse of the proper rating. OUR WARRANTY DOES NOT COVER DAMAGE CAUSED BY USE OF AN IMPROPER FUSE.

(9) Power Cord

The AC power cord emerges at this point.

(10) VIDEO OUT

The output video signal for your monitor television appears at this jack.

(11) NEG/POS

This switch selects the format for the television screen display. In the NEG position, white letters will appear on a black background; in the POS position, black letters will appear on a white background.

(12) MONITOR V/H

The V and H jacks are for connection to the vertical and horizontal deflection plate input jacks on the YO-901 Multiscope, for RTTY cross pattern monitoring.

(13) RF OUT

This is the output jack for the optional video modulator for television channels 3 or 4. Switching is performed inside the cabinet, for selecting the unused channel in your area.

(14) AF IN

This is the audio input jack for the YR-901. This jack should be connected, through a suitable patch cord, to the FT-901DM external speaker jack.

(15) TTY/KB/RTTY

This switch should be set to the position corresponding to the type of machine you will be using. For an ASR33 type machine, use the TTY position. For an ASCII keyboard, use the KB position. For an ASR32 type machine, use the RTTY position.

(16) FSK OUT

This is the teletype keying output jack, and it should be connected to the FT-901DM FSK KEY IN jack on the rear panel of the transceiver.

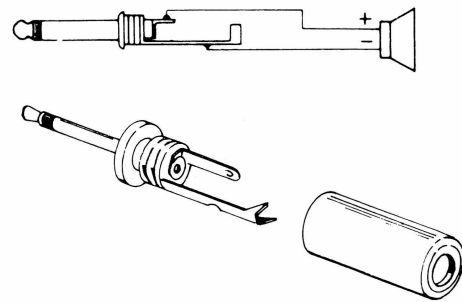

Fig.2 Speaker Plug

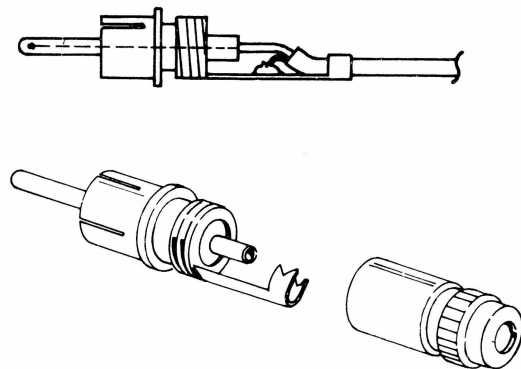

Fig.3 RCA Phono Plug

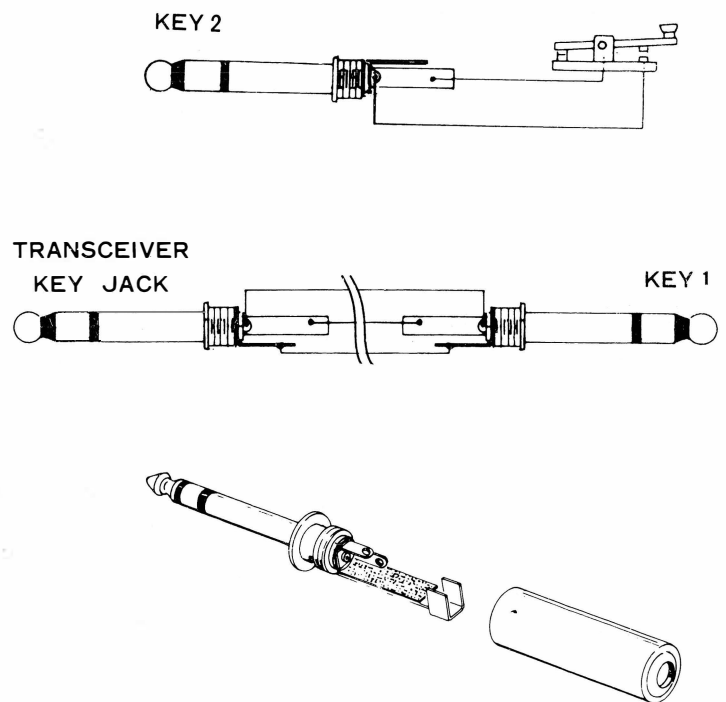

Fig.4 Key Plug

INSTALLATION

INSTALLATION

The YR-901 should be positioned near the station transceiver so that the controls and switches are easily accessible from your operating position.

Before commencing operation check to see that the voltage specification on the rear of the YR-901 matches your local supply voltage. Also, be certain to use a 1 ampere fuse in the rear apron fuse socket. These inspections must be carried out before applying AC power to the YR-901. Refer to the transformer primary connection diagram below.

CAUTION

PERMANENT DAMAGE CAN RESULT IF IMPROPER POWER IS APPLIED TO THIS INSTRUMENT. OUR WARRANTY DOES NOT COVER DAMAGE CAUSED BY IMPROPER POWER CONNECTIONS OR IMPROPER FUSE INSTALLATION.

The connections for the various operating modes are detailed in the operating instructions for that mode.

Power Transformer Primary Connections

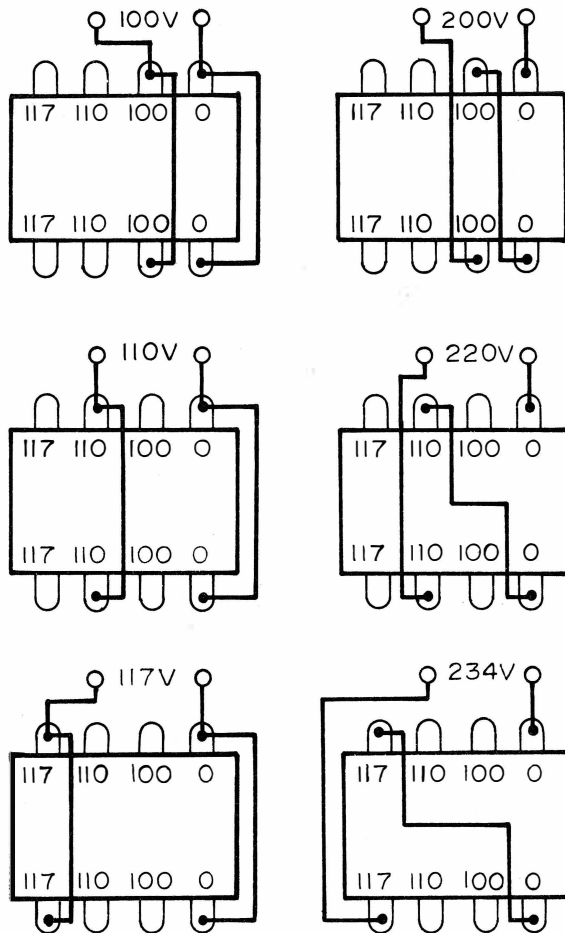

OPERATION

I. CW Monitor

Connect the YR-901, the station receiver, and the TV monitor as shown in Figures 5 and 6. When using the video modulator to drive a home television, see page 18 for details on switching between channels 3 and 4 for output from the video modulator. The output impedance from the YR-901 RF OUT jack is 75 ohms, so a balun must be installed to provide a 75 ohm to 300 ohm unbalanced to balanced feed for those televisions using 300 ohm feed only. The video modulator is an available option. See your Yaesu dealer.

We recommend that the television antenna be disconnected to avoid transmitting the YR-901 output signal from that antenna.

The preferred method of viewing the YR-901 output is on a video monitor, commonly available from computer hobby supply outlets. The correct connection method is shown in Figure 6.

When using headphones to monitor the CW output, please do not use the FT-901DM PHONES jack, as this will cut off the output from the SP jack. Instead, use the PHONES jack provided on the YR-901 front panel.

Operation

- (1) Preset the receiver for your favorite beat note on the FT-901DM marker signal.
- (2) Preset the YR-901 controls and switches as follows:
MODE CW.B (For Morse Code)
NAR/WIDE WIDE
TTY (45/50) OFF
NEG/POS POS
ACR. OFF
POWER ON
- (3) Advance the INPUT LEVEL control as necessary to obtain a 1/3 scale indication on the level indicator LEDs. Now adjust the F. ADJ control on the rear apron of the YR-901 for maximum deflection of the indicator LEDs. This will preset the input bandpass filter for maximum response on your preferred beat note. Now turn off the marker.
- (4) Tune in the desired CW signal, and adjust the INPUT LEVEL control so that the indicator

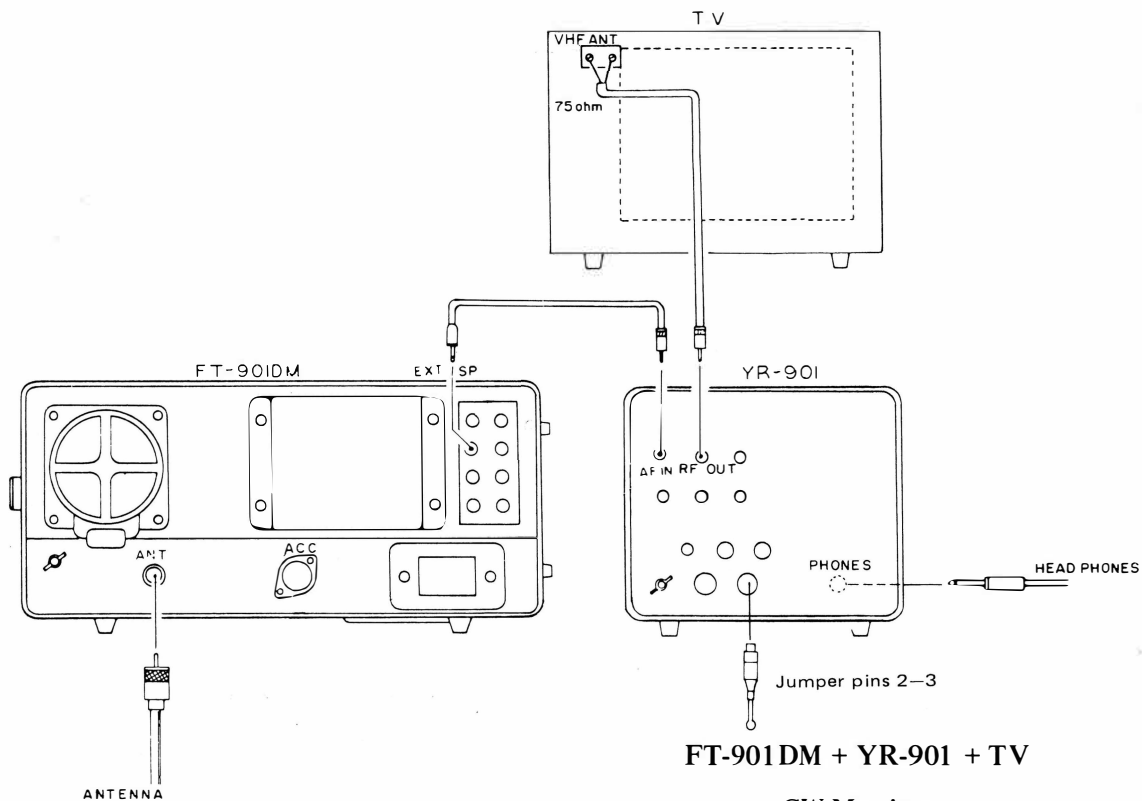

Fig.5

CW Monitor

LEDs deflect fully to the right on peaks, with the background noise at not more than half scale. The FT-901DM APF circuitry may help in securing a proper signal-to-noise ratio under difficult conditions.

- (5) Once the proper input level has been set, flip the RESET switch to clear the monitor screen and initiate signal sampling. For the first eight dots and dashes, the YR-901 will be sampling the dot, dash, and space ratio of the incoming signal. When this sampling period is finished, the sampled letters will be displayed, and the readout of the incoming signal will appear on the monitor screen. If you want to start a new page of copy, push CL; this will clear the screen, but will not initiate a new sampling cycle.
- (6) If the code speed changes by a factor of greater than three (either 3 times as fast or 1/3 as fast as the initial speed), the RESET lever must be flipped, in order to initiate a new sampling. This is because a dash at the

initial speed will appear to be a dot at three times that speed, and the YR-901 will be unable to determine the proper ratio.

- (7) Once the optimum copying tone has been secured, you may switch the input bandpass filter switch from WIDE to NAR, for even more protection from adjacent channel interference and noise. In the NAR position, the input bandwidth becomes only 20 Hz, so tuning will become critical, but the signal-to-noise ratio will be greatly improved.
- (8) To reverse the black/white relation on the monitor screen, switch the NEG/POS switch to NEG. In this mode, white letters will appear on a black background.
- (9) To hold copy in memory, press the M (Memory) switch. All copy on the screen at the moment that the switch is pressed will be held. To recall the copy, press MR (Memory Recall). The previously-stored copy will then be displayed. Note that the YR-901 will

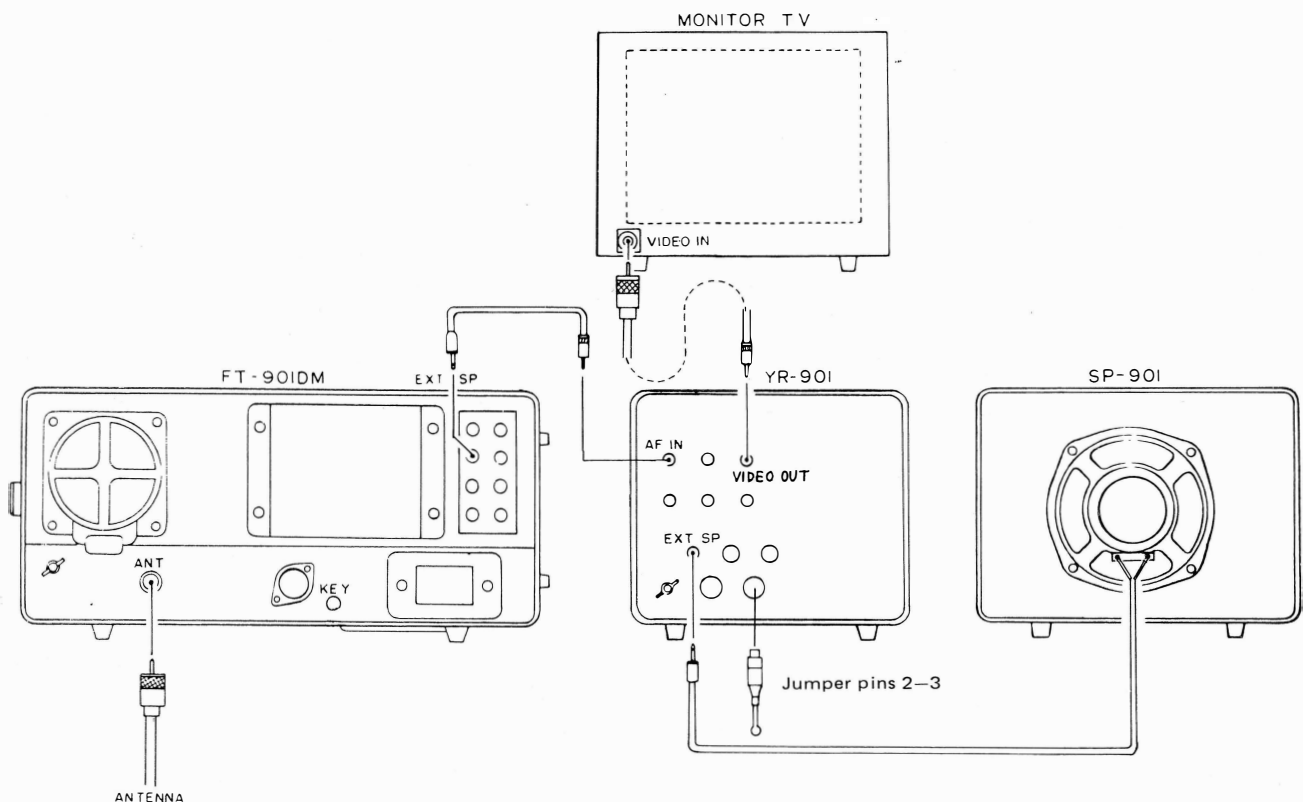

**Fig.6 FT-901DM + YR-901 + SP-901 + Video Monitor
CW Monitor**

continue copying while you are viewing the memory display, and when you return the switch to its center position, the copy will include all text received while you were viewing the memory display. The use of the memory system is especially useful when you don't want to lose what is shown on the screen, but must push the RESET button because of a change in code speeds, etc.

- (10) When the bottom of a line of copy is reached, the YR-901 will automatically drop the top line of copy, making room for the latest text at the bottom of the screen.
- (11) When the ACR (Automatic Carriage Return) switch is activated, the YR-901 will return to the beginning of the next line if there is a pause equal to 29 dots in the incoming signal.
- (12) When eight consecutive dots are received ("error" signal), the YR-901 will automatically erase the preceding word.
- (13) The CW.A mode is for monitoring of the Japanese Kana Code. When a Japanese station is heard to send "CQ T2" this means that the station intends to use the Japanese code. If you flip to the CW.A mode, the YR-901 will tell you exactly what the Japanese operator is saying (if you can read Japanese characters!).

ERROR CAUSES

When the YR-901 cannot distinguish an incoming character, the "#" symbol will appear on the screen. There are several possible causes of errors in copy.

- (1) If the input signal-to-noise ratio is not sufficient, the YR-901 may detect noise as part of the incoming signal. The indicator LEDs must be set for full scale indication on the signal, with half-scale or less indication on background noise.
- (2) If the dot/dash/space ratio is extremely poor, the YR-901 may not be able to distinguish between a dot and dash, causing an error to be displayed. The YR-901 includes an editing feature, and the initial sampling after resetting will allow for variations in sending, but there are limits in the amount of error that can be tolerated.
- (3) If the first eight characters during the sampling period are all dots or all dashes, the YR-901 will not be able to compare their relative lengths, and correct display will thus be impossible.
- (4) If two signals are zero beat with each other, it will be impossible for the YR-901 to distinguish between them. This problem may also arise during conditions of extremely heavy echo, such as that observed during long-path or around-the-world propagation.

TELETYPE RX MONITORING

- (1) Set up the YR-901 and station equipment as shown in Figures 5 and 6. If it is desired to use a monitor scope such as the YO-901, Multi-scope for cross pattern monitoring of the RTTY signal, please refer to Figure 7 for interconnection details.
- (2) Preset the controls and switches as follows:
 MODE 170 (for amateur 170 Hz shift)
 TTY 45 (45.5 Baud) or 50 (50 Baud)
 F/L OFF
 AS OFF
 NOR/REV . NOR
 A. START . OFF
 Insert the 6-pin DIN plug into J₁₀₅ (rear panel).
- (3) Tune in an RTTY signal, and adjust the INPUT LEVEL control to obtain a full scale deflection of the indicator LEDs. Now tune in the RTTY signal in such a way as to obtain equal illumination of the MARK and SPACE LEDs.

- (4) Once the signal is properly tuned, advance the INPUT LEVEL control fully clockwise. By now, you should be monitoring on the television screen the incoming RTTY message.
- (5) Observe the display on the monitor screen. If it appears that the figure/letter relationship is reversed, simply flip the F↔L switch to reverse the relationship. See also the section on ASCII Code and RTTY Code, Page 15 of this manual.
- (6) The AS (Antispace) feature will place the teletype machine in the mark-hold mode if the space signal exceeds 250 ms in length. This will prevent the teletype machine from generating unnecessary noise. OSCAR satellite transmissions may be received with this switch on or off, incidentally.
- (7) If you are using a receiver in which the BFO relationship is such that the MARK/SPACE relationship is reversed, the NOR/REV switch may be placed in the REV position, thus allowing proper operation.

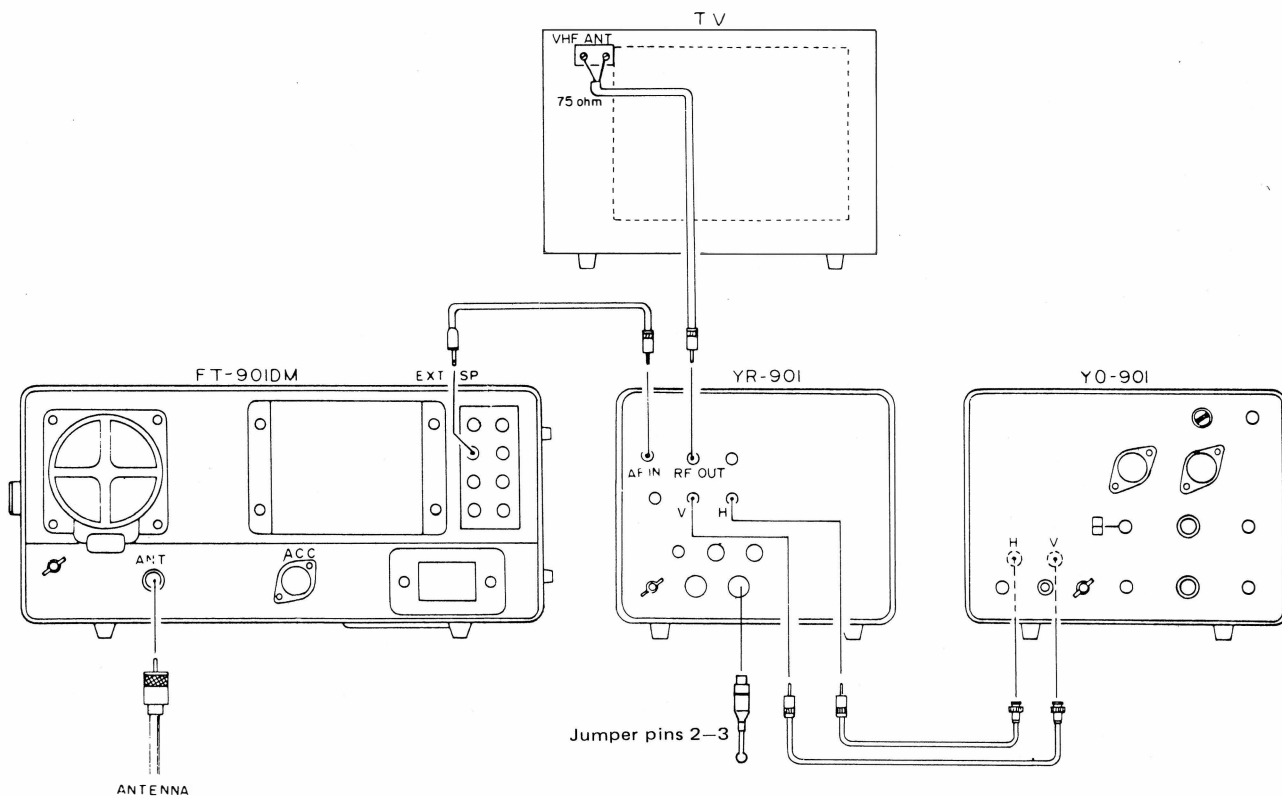

Fig. 7 FT-901DM/YR-901/YO-901/TV
Teletype RX Monitor

CW TX/RX MONITORING

Refer to Figure 8 for typical connection information for CW operation. The keyer paddle is inserted into the YR-901 rear apron KEY 2 jack, and then a patch cord is connected between the KEY 1 jack and the FT-901DM KEY jack. This setup finds its chief application when an ASCII keyboard is used, as we will explain later; for normal CW operation, it is not necessary to route the key lead through the YR-901.

The YR-901 includes provision for operation with transmitters utilizing both positive and negative keying voltages. Refer to page 18 for details of the internal switching which will allow either mode of operation. The YR-901 comes equipped for positive keying.

For positive keying, the YR-901 KEY jacks display a key-up voltage of 12 volts, with a key-down current of 50 mA. For negative keying, the key-up voltage is -25 volts, with key down current of 25 mA. If your electronic keyer is not compatible with these voltages, the use of a keying relay at the output of your keyer will solve the problem.

For your reference, typical Yaesu transceivers and transmitters are listed below.

Positive keying: FT-901 Series, FT-101Z Series, FT-7/B, FT-301 Series, FT-625R, FT-225R, etc.

Negative keying: FT-101/B/E, FT-201, FT-401 Series, FTdx 560, FLdx400, FL-101, etc.

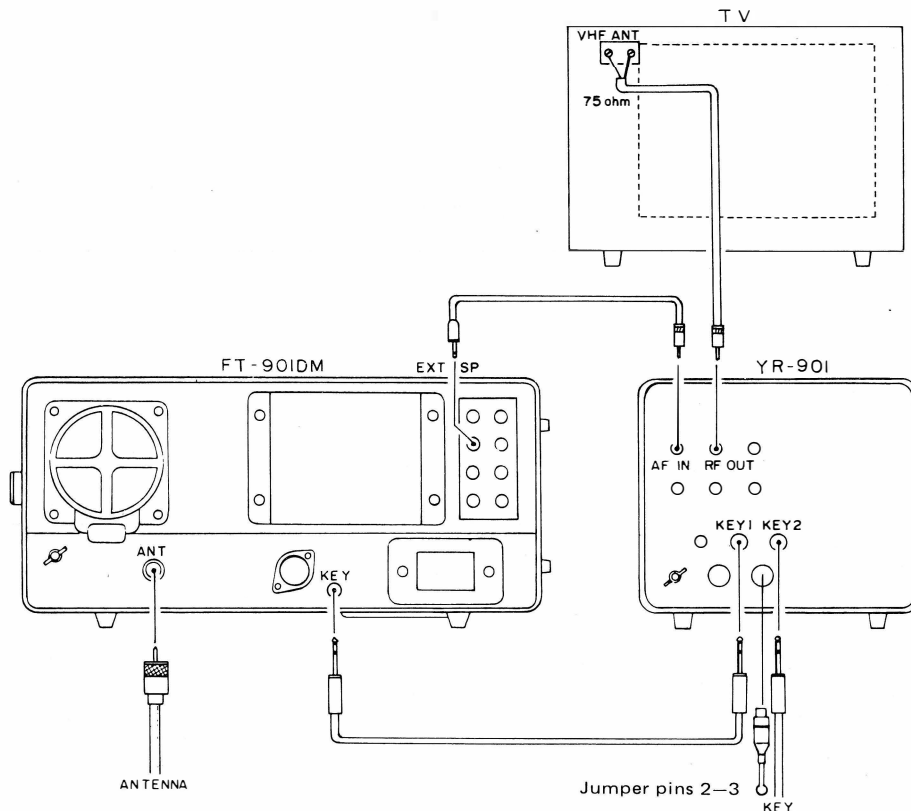

Fig.8

FT-901DM/YR-901/TV
CW TX/RX Monitor

TELETYPE MACHINE/ASCII KEYBOARD CW TX OR TX/RX OPERATION

- (1) Refer to Figure 9, and connect the FT-901DM, YR-901, and your ASCII keyboard, ASR32, or ASR33 machine. One lead not shown in the drawing (because of space limitations) is the keying output lead from the YR-901; this should be connected between the YR-901 KEY 1 jack and the FT-901DM KEY jack. If operation is contemplated using your keyer paddle, as well as the machine, connect your paddle to the YR-901 KEY 2 jack.
- (2) Be certain to insert the 6-pin DIN plug into J₁₀₅ on the rear panel when using an ASR33 machine or ASCII keyboard. When using an ASR32 machine, remove the jumper across pins 2 and 3 of the 6-pin DIN plug.
- (3) When using an ASCII keyboard which includes a 110 baud clock, no external connection will be necessary for clock operation.
- (4) When using an ASCII keyboard or ASR33 machine, place the rear apron TTY/RTTY switch in the TTY position. When using an ASR-32 machine, switch to RTTY.
- (5) When using an ASR33 machine, the position of the 45/50 baud rate switch is inconsequential. However, when using an ASR32 machine, the proper baud speed must be selected.
- (6) When the YR-901 is first activated, the receiving speed will be set by sampling of the incoming signal; this speed, in turn, will be preset for transmission as well. If no incoming signal is present, the speed will be set at 96 letters per minute for transmit. Flip the RESET button to make drastic changes in code speed, as detailed in the section dealing with CW Monitoring.

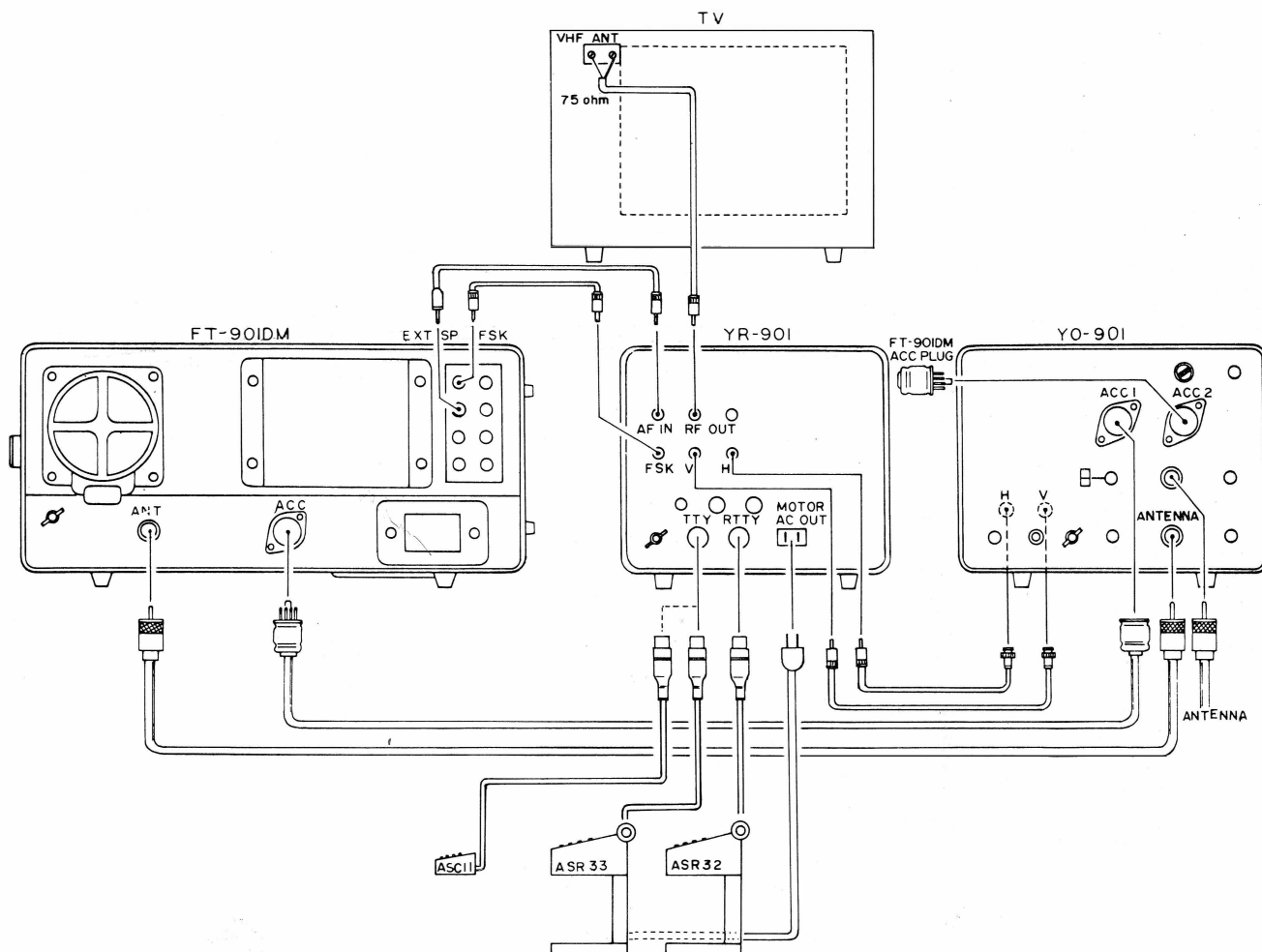
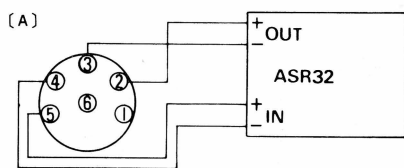
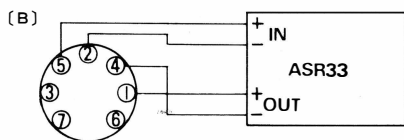

Fig.9 FT-901DM/YR-901/YO-901/TV/Keyboard

- (7) When using a keyboard or teletype machine for code generation, the FT-901DM KEYSPEED control should be set fully counterclockwise into the click-stop (manual position). When using the keyer paddle, rotate the KEYSPEED control out of the click-stop, as usual.
- (8) The YR-901 is tolerant of varying typing speeds, and the unit will hold letters that lead the actual transmission. However, if you hit two keys at the same time at a high rate of speed, one of the letters may be dropped. Therefore, an even typing style is recommended.



ASR-32 connections to J₁₀₅. Set S₁₀₂ to RTTY.



ASR-33 connections to J₁₀₆. Set S₁₀₂ to TTY.

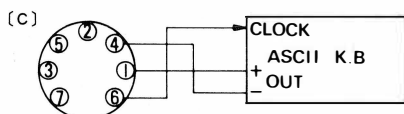

ASCII keyboard connections to J₁₀₆, using YR-901 110 baud clock. Set S₁₀₂ to KB.

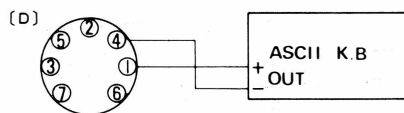

ASCII keyboard connections to J₁₀₆, using keyboard internal clock. Set S₁₀₂ to KB.

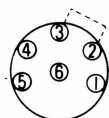

Remove jumper between pins 2 and 3 of J₁₀₅ when using (A) above.

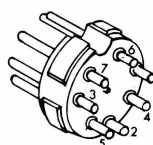

Plug for J₁₀₆

1. TTY/ASCII OUTPUT⊕
2. TTY INPUT⊖
3. TTY OUTPUT⊖(Not used)
4. TTY/ASCII OUTPUT⊖
5. TTY INPUT⊕
6. ASCII CLOCK OUTPUT
7. TTY OUTPUT⊕(Not used)

TELETYPE TX/RX OPERATION

- (1) Refer to Figure 9 for interconnection details. The proper connection of the YO-901 Multi-scope is also shown, for cross pattern monitoring. When using the YO-901, do not forget to insert the FT-901DM ACC plug into the ACC 2 jack on the rear apron of the YO-901. Observe the proper connections at J₁₀₅ as described in step (2) on page 14.
- (2) Set up the FT-901DM for FSK operation in the usual manner.
- (3) When using an ASR33 or ASCII keyboard, do not lead the display excessively nor type in an uneven manner. This may cause letters to be lost. This is a precaution to be observed for any teletype generating device.
- (4) When using an ASCII keyboard, the figure/letter relationship must be preset at the start of each line, as the ASCII keyboard does not have a shift key. At the start of the line, set the F/L switch to the locking F/L position (up), and type in a letter (if the first character is a letter) or a figure (if the first character is a figure). Then return the F/L switch to the center position, and continue typing. Typical examples of the above procedure follow:

- (a) If the first word of a line is "THE" proceed as follows:
 F/L UP
 (Type) T (or any letter)
 F/L DOWN (To center position)
 (Type) THE QUICK BROWN FOX. . .
- (b) If the first group of a line is "2SC1815Y" proceed as follows:
 F/L UP
 (Type) 2 (or any figure)
 F/L DOWN (To center position)
 (Type) 2SC1815Y TRANSISTORS ARE USED. . .

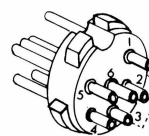

Plug for J₁₀₅

1. F/L CONTROL(Not used)
2. TTY OUTPUT⊕
3. TTY OUTPUT⊖
4. TTY INPUT⊖
5. TTY INPUT⊕

Fig. 10 Keyboard Connections

- (5) When you come to the end of the line, push the keyboard CR (Carriage Return) key twice, and the LF (Line Feed) key once, as needed, to ensure that the teletype machine on the other end responds properly.
- (6) The motor auto start feature can be activated by flipping on the front panel A. START switch. When the teletype machine motor AC cord is connected to the rear apron MOTOR AC OUT jack, the machine's motor will remain off until a SPACE signal is received. With the A. START switch OFF, 117 VAC (or your local house current) will always be present at the MOTOR AC OUT jack.

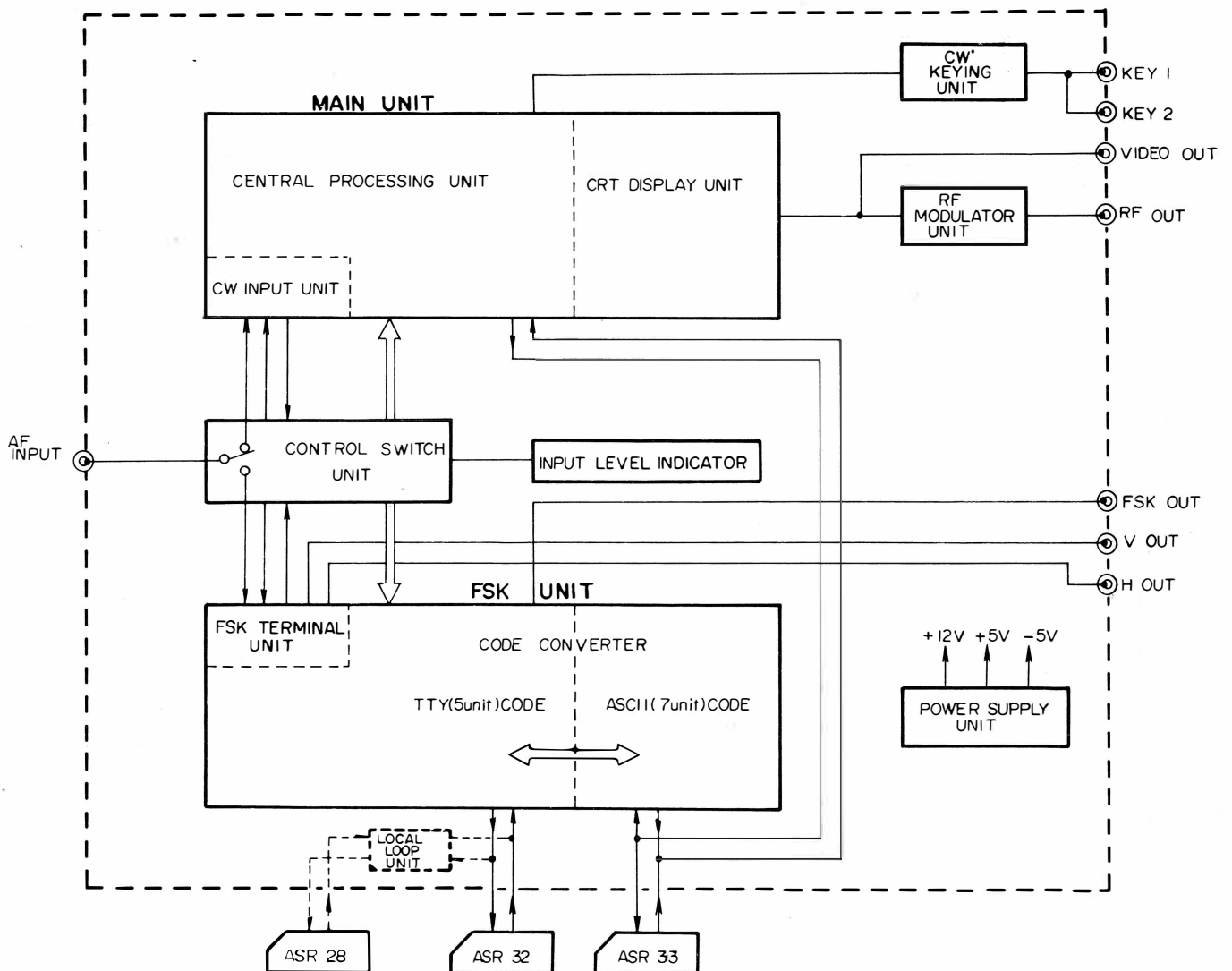

Fig. 11 Function Diagram

CIRCUIT DESCRIPTION

A full description of every logic state in the YR-901 is well beyond the scope of this manual. In order to help you understand the YR-901 better, we are presenting a simplified explanation of the basic functions of the various units involved in the code translation process. Refer to the block diagram and schematics for details.

CW RX MONITOR

The 800 Hz Morse audio input from the receiver arrives at the CW INPUT UNIT, where the signal is passed through a highly selective active audio filter. The signal is then fed to the Central Processing Unit (CPU).

At the CPU, sampling is made of the comparative lengths of the dot, dash (3 dot lengths), letter space (3 dot lengths), and word space (7 dot lengths) on the incoming signal. Once the sampling is completed (after eight letters), the CPU is preset, and normal monitoring will occur.

The output from the CPU is fed to a character generator in the CRT DISPLAY UNIT, which will drive the video monitor or RF MODULATOR UNIT. A portion of the output from the CPU is also fed to the FSK UNIT, when using a teletype machine for printout of the incoming Morse signal.

CW TX MONITOR

When using an electronic keyer for CW operation, the sidetone output from the transceiver is fed to the CPU in the same way as an incoming RX signal for display on the monitor. When using an ASCII keyboard, etc., the output drives the CPU directly for translation and display.

When using an ASR32 type machine, the 5 unit code is translated to 7 unit code in the Code Converter of the FSK UNIT. The output signal is then applied to the CPU for processing; the output from the CPU is fed to the CW KEYING UNIT, where a switching transistor is used for the ON/OFF output to the KEY 1 and KEY 2 jacks.

In the case of the ASR33 type machine, the 5 unit to 7 unit translation is not required, and the keyboard output is applied directly to the CPU. At the

CPU, the teletype code is translated to Morse, and the output drives the CW KEYING UNIT. The output is also fed to the CRT DISPLAY UNIT for display on the monitor.

TELETYPE RX MONITOR

The input audio FSK signal from the AF IN jack is applied to the FSK TERMINAL UNIT, and from there to the Code Converter. For input to the CPU, incoming 5 unit code is translated into 7 unit code, and then fed to the CPU and CRT display. For direct printout on an ASR32 machine, no translation to 7 unit code is performed. The 7 unit code is also fed to the printer of the ASR33 type machine, when used.

TELETYPE TX MONITOR

The output from an ASR32 machine is maintained in 5 unit code, and fed to the FSK OUT terminal from the FSK UNIT. The display of the output on the video monitor requires translation to 7 unit code, and this is performed, as before, in the Code Converter; the signal is then delivered to the CPU.

When using an ASR33 machine, the 7 unit output from the machine is translated to 5 unit code at the Code Converter, and the output is then fed to the FSK OUT terminal. The 7 unit code is fed to the CPU for subsequent display on the monitor.

MAINTENANCE AND ALIGNMENT

The YR-901 should never require alignment, if it is not abused. Conditions of improper operation can usually be traced to insufficient input level, poor sending on the other end, or parts failure in the YR-901. If servicing is required, we recommend that the YR-901 be returned to the dealer from whom it was purchased, as any attempts to align the critical circuitry in the YR-901 without the proper knowledge will result in degraded performance.

The case of the YR-901 may be wiped with a damp cloth whenever necessary. Accumulated dust may be blown out of the interior with moderate-force compressed air.

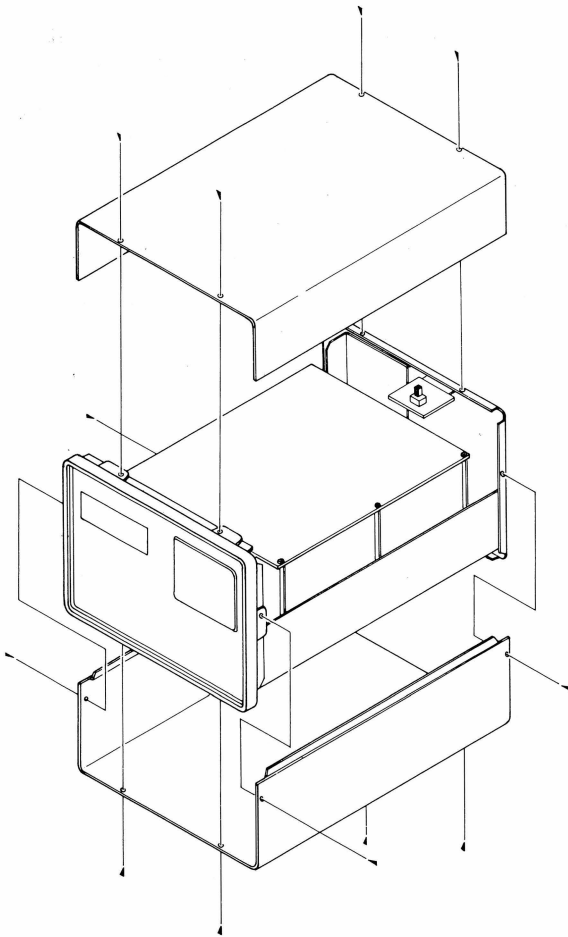

Fig. 12 Case Disassembly

KEYING POLARITY CHANGE

When using a transceiver utilizing negative keying (see list on page 13), the output polarity from the CW KEYING UNIT must be changed.

Locate switch B in Figure 13. Set this switch to – for negative keying. When returning to a transceiver using positive keying, this switch must be returned to +.

In the negative position, key-up voltage is –25 volts. In the positive position, key-up voltage is 12 volts. The key down current is 50 mA.

VIDEO MODULATOR CHANNEL CHANGE

The video RF output from the video modulator can be changed between channels 3 and 4 by a simple procedure.

Locate the switch marked A in Figure 14. At this switch, there are two marks: H and L. For channel 3, set this switch to L, and for channel 4, set the switch to H. No further adjustment is required.

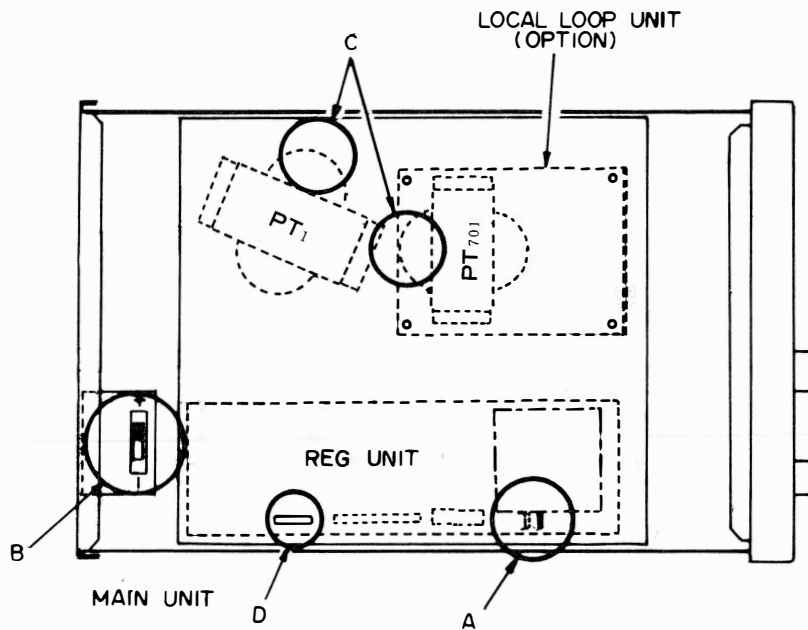

Fig. 13

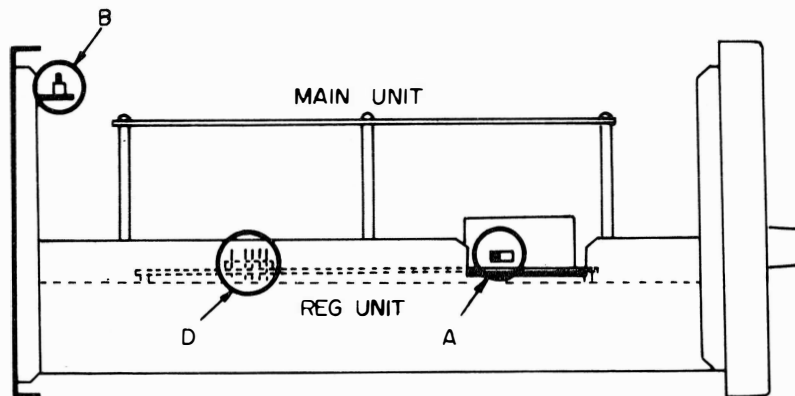

Fig. 14

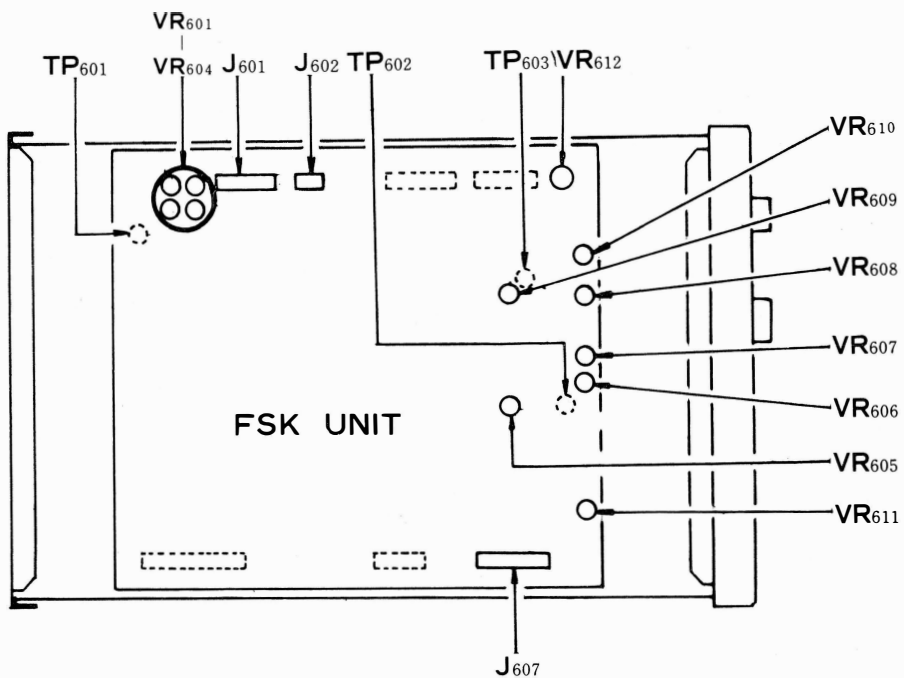

Fig. 15

TELETYPE BAUD CHANGE

The YR-901 comes equipped for 45.5 and 50 baud operation. If you desire to use 57 and 75 baud, a simple modification is required.

- (1) Remove the case of the YR-901.
- (2) Refer to Figure 15, and locate P₁₀₉, marked F. Remove P₁₀₉ from its jack.
- (3) Refer to Figure 16, and locate the 45.5 baud line (white/yellow, connected to pin 8). Also locate the 50 baud line (white/green, connected to pin 7). These may be moved to pin 9 for 57 baud and pin 6 for 75 baud operation, respectively. To remove the pins from the connector, poke a narrow object into the hole corresponding to the desired pin, in order to free the locking head of the pin.
- (4) Normally, no alignment will be required. If the baud rate is seriously out of alignment, though, the following procedure may be performed.
 - (a) Locate VR₆₀₁–VR₆₀₄, marked G in Figure 15. Connect a frequency counter to TP₆₀₁, and set the TTY switch to 45. Adjust VR₆₀₁ for a reading of 728 Hz on the counter.
 - (b) In the same manner, set the TTY switch to 50, and adjust VR₆₀₂ for a reading of 800 Hz on the counter.
 - (c) If the modification described previously has been performed, allowing 57 and 75 baud operation, adjust VR₆₀₃ (57 baud) for a reading of 912 Hz, and VR₆₀₄ (75 baud) for a reading of 1200 Hz, with the TTY switch set to the proper position.

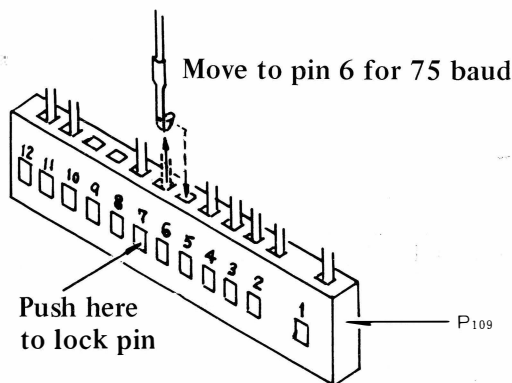

Fig. 16

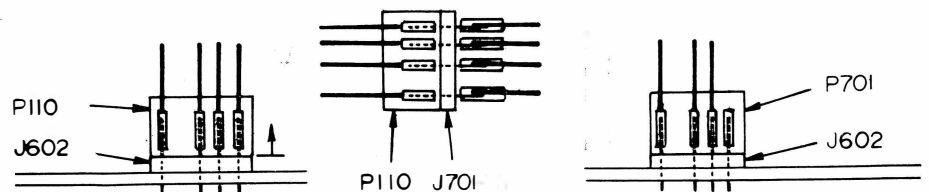

Fig. 17

LOCAL LOOP UNIT INSTALLATION (OPTION)

When using an ASR28 type machine, the current requirements of the machine must be met. The standard YR-901 will not handle this current, but with the addition of the optional LOCAL LOOP UNIT, proper operation is possible. This unit need not be switched out of the circuit when using ASR32 or ASR33 machines.

- (1) Remove the case of the YR-901. Remove the Molex plugs from the sockets on the MAIN UNIT, and note their position carefully. Remove the mounting screws for the MAIN UNIT, and remove this unit from the case.
- (2) Install the LOCAL LOOP UNIT in the position shown in Figure 13, being certain to position it correctly (the power transformer of the LOCAL LOOP UNIT should be adjacent to the main power transformer). Now connect the two parallel wires shown in Figure 18 between the LOCAL LOOP power transformer and the main power transformer. Check to make sure that the primary winding on the LOCAL LOOP transformer is the same as that on the main transformer.
- (3) Locate 4-pin P₁₁₀/J₆₀₂, marked E in Figures 14 and 17. Also locate J₇₀₁ and P₇₀₁ (from the LOCAL LOOP UNIT). Remove P₁₁₀ from J₆₀₂, and connect P₁₁₀ to J₇₀₁, as shown in Figure 17. Now connect P₇₀₁ to J₆₀₂, as shown in Figure 17.
- (4) Locate the 5-pin connector from the LOCAL LOOP UNIT. Connect this to J₂₀₄, marked D in Figures 13 and 14.
- (5) Carefully re-install the MAIN UNIT, being especially careful not to bend the leads of the various connectors. Close up the case.

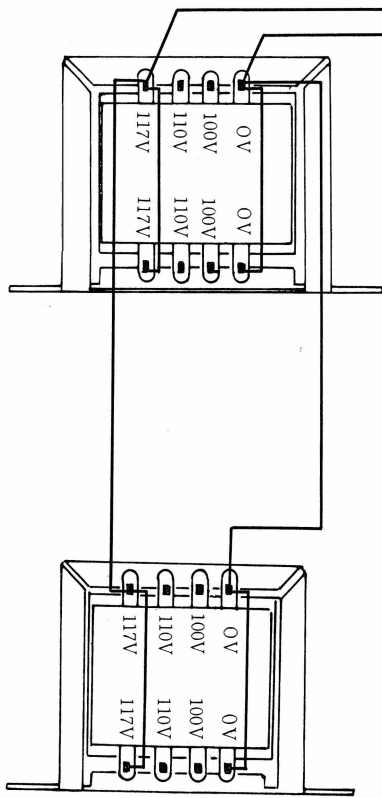

Fig. 18

FSK BANDPASS FILTER ADJUSTMENT

- (1) Set the MODE switch to the FSK/170 position, and connect a precision audio signal generator to the AF IN jack. Set its output to 1 volt at 2125 Hz. Now adjust VR₆₀₆ for maximum indication on the indicator LEDs, adjusting the input from the generator as necessary.
- (2) Set the audio generator to 2295 Hz, and adjust VR₆₀₇ for a maximum deflection on LED display.
- (3) Set the MODE switch to FSK/425, and set the audio generator output to 2550 Hz. Adjust VR₆₀₈ for maximum deflection of the indicator LEDs.
- (4) Set the MODE switch to FSK/850, and set the audio generator output to 2975. Adjust VR₆₀₉ for maximum deflection of the indicator LEDs.

AUTO START DELAY ADJUSTMENT

The stop delay time of the auto start feature may be varied between 20 and 150 seconds by adjustment of VR₆₁₂.

OPERATIONAL AMPLIFIER BALANCE ADJUSTMENT

This section details the procedure for setting the balance of IC642 and IC644.

- (1) Locate miniconnector J₆₀₇/P₁₁₅. Connect a short between pins 11 and 12 of this connector. Now connect a DC voltmeter between TP₆₀₂ and ground, and adjust VR₆₀₅ for a reading of exactly 6 volts. Now remove the shorting wire at pins 11/12.
- (2) Connect the DC voltmeter to TP₆₀₃, and adjust VR₆₁₀ for a reading of exactly 6 volts.
- (3) Set the MODE switch to any of the FSK positions. With no signal input, and the INPUT LEVEL control set fully counter-clockwise, adjust VR₆₁₁ for an exactly half-scale indication on the LED indicator display (6 LEDs illuminated). Now flip the NOR/REV switch, and adjust VR₆₁₀ and VR₆₁₁, as necessary, to obtain an identical half-scale display in both the NOR and REV modes.

PARTS LIST

MAIN CHASSIS			P109(with wire)	T9201610	5047-12
Symbol No.	Parts No.	Description	P110(")	T9201670	5047-04
		DIODE	P111(")	T9201660A	5047-17
D102	G2015550	Silicon 1S1555	P112(")	T9201650	5047-14
			P113(")	T9201640	5047-08
			P114(")	T9201680A	5047-06
		RESISTOR	P116(")	T9201690	5047-04
R101	J10276100	Carbon composition 1/2W GK 10Ω	P117(")	P0090068	IC-49-P4
R102	J01245101	Carbon film 1/4W TJ 100Ω			
					FUSE
			F101	Q0000002	1A
		POTENTIOMETER			
VR101	J60800053	EVH-COAS25B53 5kΩB			
VR102	J61800011	EWK-DOAS10B15 100kΩB			FUSE HOLDER
			FH101	P2000002	SN1301
		CAPACITOR			
C101	K14170473	Ceramic disc 50WV 0.047μF		Q6000004	TERMINAL BOARD 1L2P (2-0)
		INDUCTOR			AC POWER CORD
L101, 102	L1190017	FL-5H-102K 1mH		T9000180	2 wire, 2 prong plug
				T9000482	3 wire, 3 prong UL plug
				T9000680	3 wire, 3 prong Australia plug
		POWER TRANSFORMER		T9000684	3 wire, 2 prong EU plug
PT101	L3030020B	#230020B			
		SPEAKER			
SP101	M4090022	SA77K-Y 4Ω 3W			
					POWER SUPPLY UNIT
			Symbol No.	Parts No.	Description
		RELAY	PB-1901	F0001901	Printed Circuit Board
RL101	M1090008	MX2F DC 12V		C0019010	PCB with Components
		SWITCH			
S101	N2090013	8H2011			IC, TRANSISTOR
S102	N6090002	SSH-23-08	Q202	G1090065	IC μPC14305
S103	N6090004	SSF-22-08B	Q201	G1090114	" μPC14312
S104	N0190030	ESR-E365R25B	Q204	G3107330	Tr 2SA733
			Q203	G3090028	" MJE2955
		RECEPTACLE			
J101	P1090004	SG-7814			DIODE
J102, 103	P1090001	SG-7701	D201	G2090001	Silicon 10D1
J104	P1090005	SG-8050	D204	G2090002	" 10D10
J105	P1090033	D6-701B-00	D202	G2090031	" S4VB10
J106	P1090034	D7-701B-00	D203	G2090025	Zener WZ050
J107	P1090098	S2-723B-10			
J108~113	R7053870	PIN JACK BOARD			
					RESISTOR
			R205	J01245100	Carbon film 1/4W TJ 10Ω
			R201	J01245271	" " " " 270Ω
P101	P0090018	STP 58	R202	J01245561	" " " " 560Ω
P102	P1090100	5065-04 (N2)	R203	J30356039	Cement 3W 0.3Ω
(with PT101)			R204	J10276479	Carbon Composition 1/2W 4.7Ω
P103(with wire)	T9201710A	5047-18			RC12GK4R7
P104(")		5047-10			
P105(")	T9201630	5047-09			CAPACITOR
P106(")	T9201620	5047-11	C201, 202	K12329004	Ceramic 1.4KV 0.047μF
P107(")	T9201730	5047-19	C209	K40100227	Electrolytic 10WV 220μF
P108(")	T9201600	5047-05	C204, 206, 208	K40120106	" 16WV 10μF
P115(")		5047-12	C205	K40120337	" " 330μF

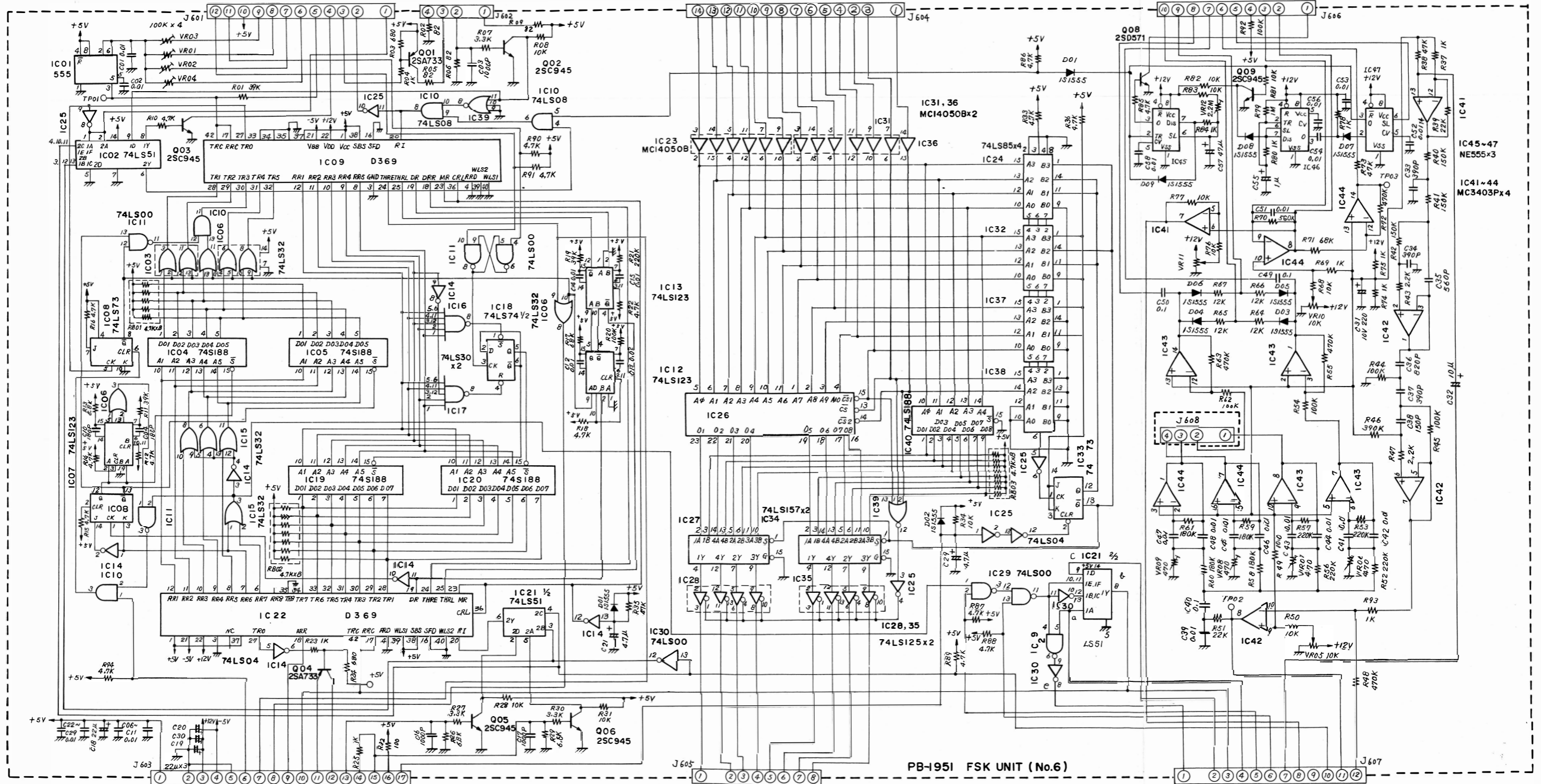

NOTES
 1 ALL RESISTORS ARE IN 1/4w UNLESS OTHERWISE NOTED
 2 ALL CAPACITORS ARE IN uF 16wv UNLESS OTHERWISE NOTED

YR-901 FSK UNIT
CIRCUIT DIAGRAM

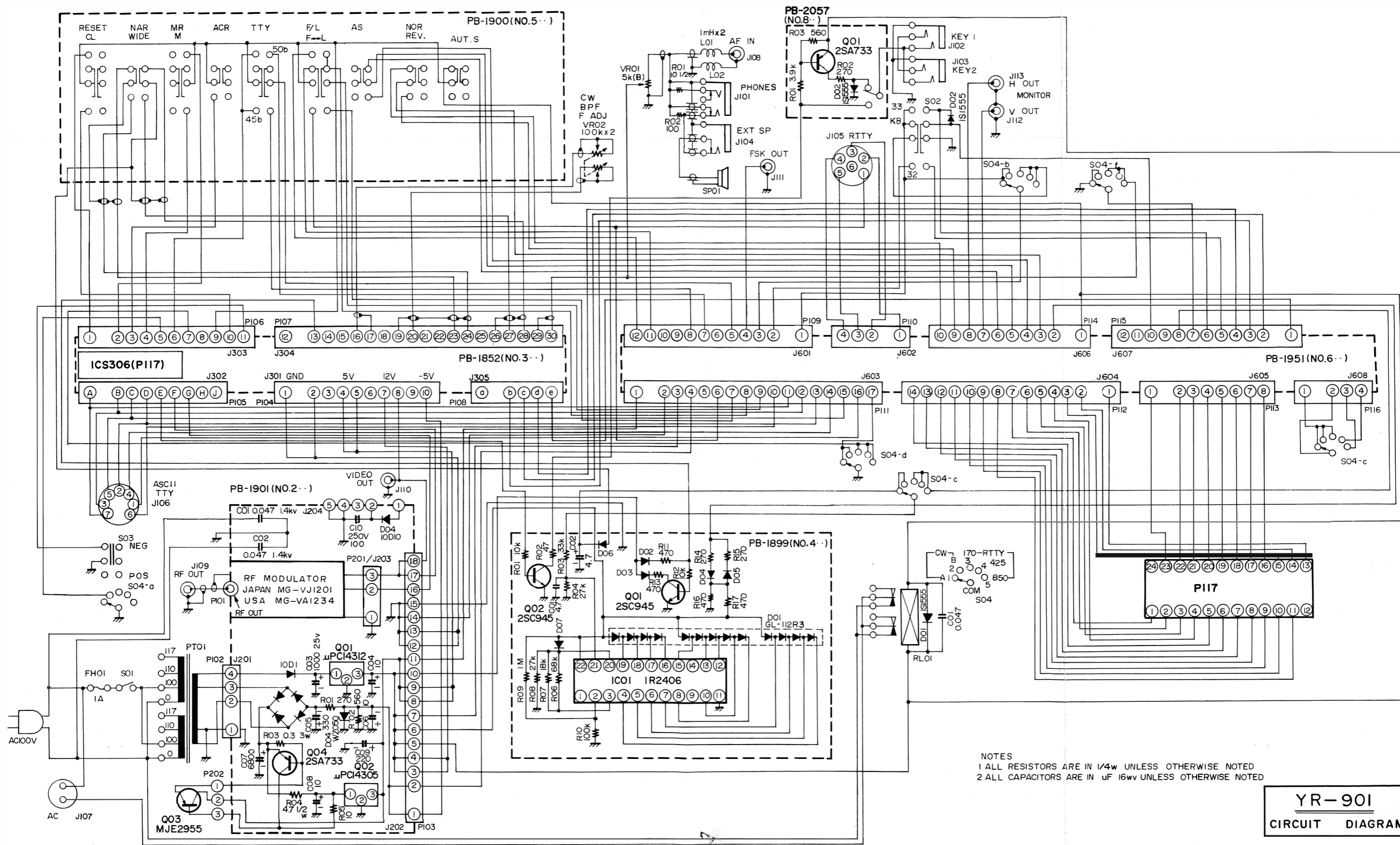

NOTES
 1 ALL RESISTORS ARE IN 1/4w UNLESS OTHERWISE NOTED
 2 ALL CAPACITORS ARE IN uf 16wv UNLESS OTHERWISE NOTED

YR-901
 CIRCUIT DIAGRAM

PB-1852 MAIN UNIT (No.3)

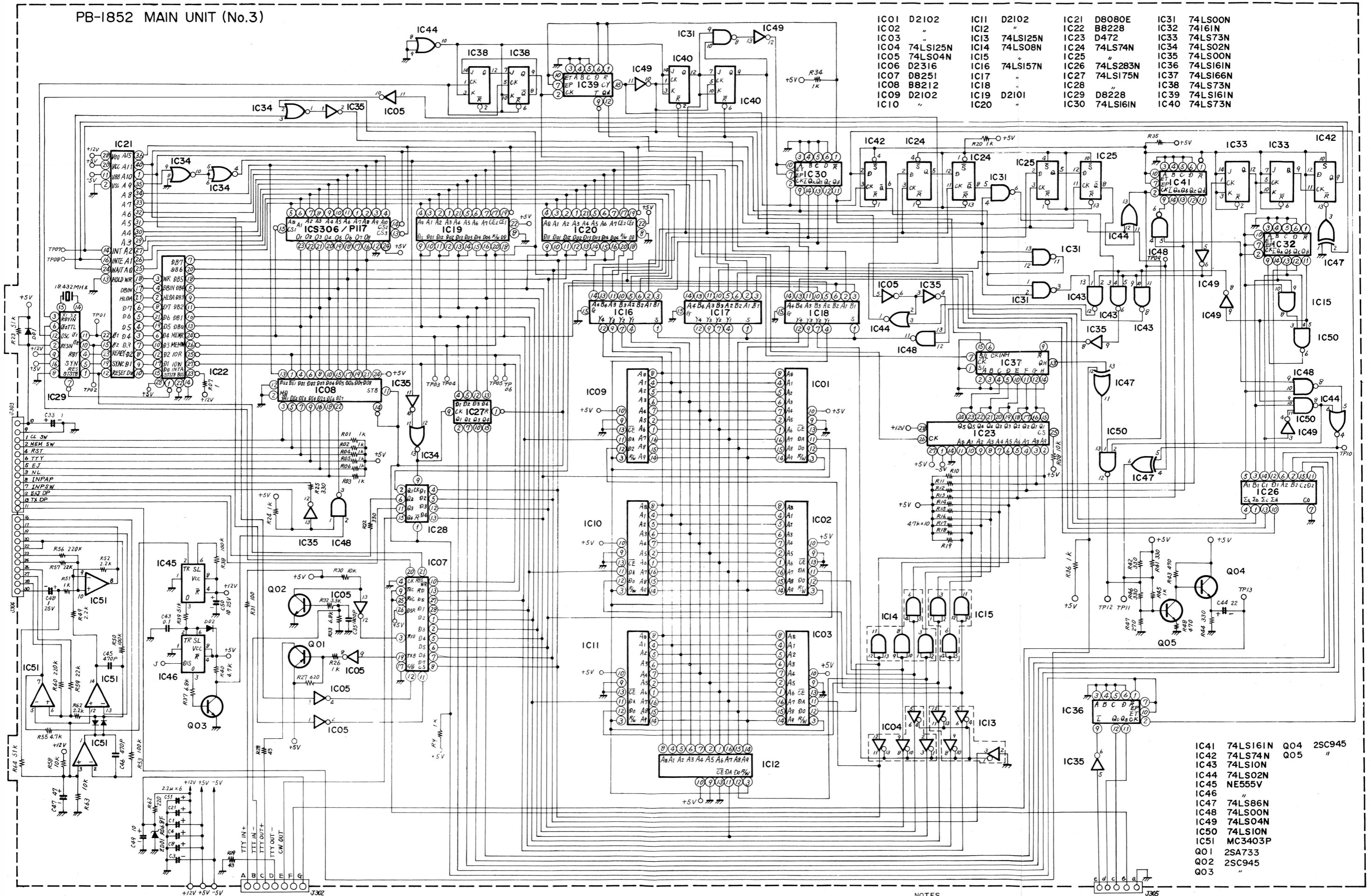

IC01	D2102	IC11	D2102	IC21	D8080E	IC31	74LS00N
IC02	"	IC12	"	IC22	B8228	IC32	7416IN
IC03	"	IC13	74LS125N	IC23	D472	IC33	74LS73N
IC04	74LS125N	IC14	74LS08N	IC24	74LS74N	IC34	74LS02N
IC05	74LS04N	IC15	"	IC25	"	IC35	74LS00N
IC06	D2316	IC16	74LS157N	IC26	74LS283N	IC36	74LS161N
IC07	D8251	IC17	"	IC27	74LS175N	IC37	74LS166N
IC08	B8212	IC18	"	IC28	"	IC38	74LS73N
IC09	D2102	IC19	D2101	IC29	D8228	IC39	74LS161N
IC10	"	IC20	"	IC30	74LS161N	IC40	74LS73N

IC41	74LS161N	Q04	2SC945
IC42	74LS74N	Q05	"
IC43	74LS10N		
IC44	74LS02N		
IC45	NE555V		
IC46	"		
IC47	74LS86N		
IC48	74LS00N		
IC49	74LS04N		
IC50	74LS10N		
IC51	MC3403P		
Q01	2SA733		
Q02	2SC945		
Q03	"		

NOTES
 1 ALL RESISTORS ARE IN 1/4W UNLESS OTHERWISE NOTED.
 2 ALL CAPACITORS ARE IN μ F 16WV UNLESS OTHERWISE NOTED

YR-901 MAIN UNIT
 CIRCUIT DIAGRAM

CAUTION

The low mark AFSK unit will only work with YR-901s having a serial number of 040001 or higher. If your CW/RTTY READER isn't equipped for AFSK operation, make certain that the rear panel switch is in the FSK position.

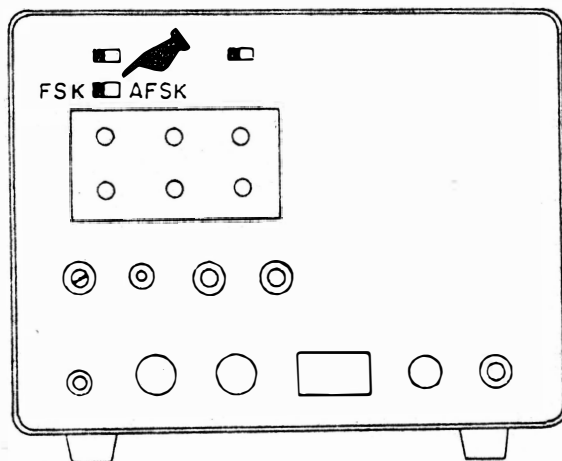

NOTE REGARDING WARRANTY SERVICE

Your Yaesu equipment is backed by a warranty that guarantees your set to be free of defects. Take a few minutes to read the warranty card carefully, and make certain that you fill out the card completely and mail it at once in order to qualify for warranty service.

Warranty service is to be performed by the dealer from whom the equipment was purchased. Do not return the equipment to Yaesu for servicing without first getting a service authorization from the Yaesu Service Center. Estimates of the approximate cost to repair are available upon request.

