

INSTRUCTION MANUAL

YAESU

FR-50B



Notes: Changed kc/s and mc/s to kHz and MHz respectively
Changed sized and weights to metric
Any errors I found have been corrected.
I have resisted making wholesale changes to the language used in the original instruction, where I have added comments these are in *{italics}*.
References to AVC have been changed to AGC.

Version: 17 December 2018

FR-50B COMMUNICATION RECEIVER

The model FR-50B Communication Receiver, designed for the amateur bands, provides a high degree of sensitivity, selectivity and stability.

Basically, it is a double conversion super-heterodyne receiver employing a variable oscillator for the first mixer stage, and a crystal controlled oscillator for the second mixer stage.

Adequate selectivity is provided for SSB, AM and CW with the utilization of two 4 Kc/s mechanical filters.

When used in conjunction with the FL-50B Transmitter, transceive operation - receiving and transmitting on the same frequency - is possible. This is a useful feature for SSB communication.

A built-in monitor circuit enables monitoring of the station transmitted signal at any time.

SPECIFICATIONS

Frequency range	80m	3.5 -- 3.8 MHz
	40m	7.0 -- 7.5 MHz
	20m	14.0 -- 14.5 MHz
	15m	21.0 -- 21.5 MHz
	10m	28.0 -- 29.2 MHz
	JJY/WWV	10.0 -- 10.5 MHz (can be installed)

{The AUX position on my receiver covered 1.2 - 1.7 MHz and appeared to be factory fitted.}

Sensitivity	CW/SSB	Less than 0.5 μ V for 10dB S/N ratio
	AM	Less than 1 μ V for 10dB S/N ratio

Selectivity At \pm 5 kHz, -50 dB. At \pm 1.8 kHz, -6 dB

Image ratio More than 50 dB.

Calibrator 100 kHz (crystal option)

Audio output 1.5 W into 4 ohm/600 ohm, speaker built-in

Power source 220 / 240 V, 50 Hz, 50VA

Dimensions 33cm wide, 15.24cm high, 26cm deep

Weight 8 kg approx.

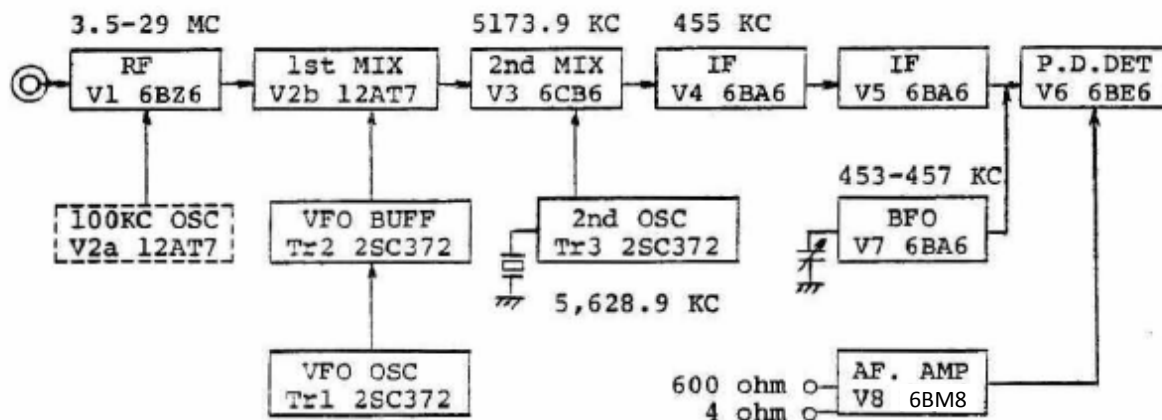

VFO Tuning Ranges

3.5 Mc band	8,672.4 -- 9,172.4 Kc	500 Kc coverage
7.0 " "	12,172.4 -- 12,672.4 Kc	" " "
14 " "	8,827.6 -- 9,327.6 Kc	" " "
21 " "	15,827.6 -- 16,277.6 Kc	" " "
28 " "	22,827.6 -- 24,027.6 Kc	1.2 Mc "

Figure 1. Receiver Block diagram {V8 changed from 6AW6 to 6BM8}

CIRCUIT DESCRIPTION

1. RF Amplifier

The high Gm tube V1 (6BZ6) provides a minimum of cross modulation. It is a semi-remote cutoff pentode and has an excellent AGC characteristic. A 5 MHz trap is inserted to reject a spurious signal which could enter directly into the first I.F. stage. To avoid complexity, two coils in each of the grid and plate tuning circuits, together with switched capacitors, cover the full range. A FM type variable condenser is used with electronic band spread for pre-selector tuning. The centre of each amateur band is approximately at the centre of the range of the pre-selector control. On the 3.5 MHz band, the pre-selector covers 3.5 - 3.8 MHz.

2. 1st Mixer

The amplified signal and local oscillator output are mixed by introducing to the grid and cathode of triode mixer V2, 12AT7. The triode mixer is very effective because of its low conversion noise. The first I.F. is 5 173.9 kHz.

3. VFO

Silicon transistor Tr1, type 2SC373, is employed on a colpitts oscillator circuit. Oscillator frequency range is selected by switching a coil for each band. C61, C63, C65, C67, C69, C71 and

C72 are temperature compensating capacitors which insure stability even in the 28 MHz band. Using the same dial mechanism as the FR-100B, with the 50 kHz variation per revolution of the knob, it is very effective for SSB and CW tuning.

Buffer amplifier Tr2, silicon transistor type 2SC372, is employed in an emitter follower circuit. Its output is injected to the first grid of mixer tube V2 (12AT7), and is also used as a VFO source for the transmitter when connected for transceiving. The output terminal is located on the rear panel of the receiver.

{This output terminal is where I have connected a frequency counter that displays the received frequency.}

4. 1st I.F.

The signal converted into the 1st I.F., 5 173.9 kHz, by the 1st mixer, is applied to the 2nd mixer via transformer L6.

5. 2nd Mixer

1st I.F. and 2nd local oscillator signals are added at the control grid of V3, a 6CB6, and results in a second I.F. at 455 kHz at the plate of the tube.

6. 2nd Local Oscillator

Tr3, silicon transistor type 2SC372, together with a quartz crystal (X1) and other parts are installed in an I.F.T. case. Output of the 2nd local oscillator is applied to the control grid of V3 (6CB6) through transformer L19. Oscillator frequency is 5 628.9 kHz.

7. 2nd I.F. Amplifier

This is a two stage amplifier using two 6BA6 coupled by two 4 kHz mechanical filters. "S" meter is inserted in the cathode circuit of the second 6BA6 (V5) and must be adjusted to indicate zero with no input signal. The "S" meter indicates cathode voltage variation in V5, which is proportional to the AGC voltage. A diode in series with the "S" meter protects it from inverse deflection. Cathode return of V4 together with that of the RF tube (V1) is connected to the RF GAIN potentiometer (VR1). {My receiver as well as the schematics I have seen do not have this diode in series with the "S" meter}

8. AM Detector & Noise Limiter Circuit

Gold bonded diode, 1S1007 (D4), is used for AM detection. Series type automatic noise limiter (ANL), with silicon diode 1S1941 (D2) effectively suppresses pulse noise. The ANL may be switched off at the front panel.

9. SSB & CW Detector

Product detector V6, 6BE6, has a very efficient performance for SSB and CW detection. BFO voltage is derived from V7,6BA6, in a self-excited oscillator circuit. BFO pitch is controlled by trimmer condenser VC4.

10. Automatic Gain Control (AGC) Circuit

AGC voltage from the AM detector is applied to control grids of V1, V4 and V5. The AGC circuit keeps the output level of the receiver almost constant regardless of input signal strength. In the case of reception of DX (CW & SSB signals), the AGC circuit may be switched off and RF GAIN control adjusted for good reception quality.

{My receiver does not have a switch to turn the AGC off - I suspect that this is legacy text from the first model of the receiver (FR-50) and instead a slow/fast AGC switch took the place of the AGC on/off switch on the FR-50B model}

11. Mute & Monitor Circuit

Adoption of a muting circuit enables smooth switching of transmit and receive. RF GAIN control VR1, and monitor control VR2 are in series to cathode return circuit of V1 and V4. For muting with a transmitter, relay contacts must open on "transmit" and close on "receive". Thus, on "receive", the mute terminal is grounded. On "transmit", the monitor potentiometer increases the bias.

{The relay mentioned here is part of the FL-50B transmitter}

12. A.F. Amplifier

Output from the detector, through the mode switch (S3), is applied to the triode section of V8 (6BM8), from which output is coupled to the power amplifier, the pentode section of V8.

Since the same circuit is used for the speaker connection and headphone jack, low impedance speaker or headphones, 4 - 8 ohms, should be used. The output transformer (T2) also has a 600 ohm winding to supply anti-trip signal for a VOX circuit.

13. Power Supply

HT supply consists of four silicon diodes (D5, D6, D7 & D8) in a bridge circuit and with a filter choke performs with good regulation. Supply for the transistor oscillator is stabilized by a zener diode 1S225. Heater supply is 6.3 volts, same as that of the FL-50B.

{The original diode in my receiver is a 1N4740 which appears to be an equivalent zener diode}

OPERATION OF RECEIVER

The following operating conditions should be observed.

1. Antenna

The antenna input impedance of the FR-50B is 50 - 70 ohms. Use a matching antenna with coaxial lead-in. The receiving sensitivity is directly dependent on the quality of the antenna. However, a length of wire will suffice for casual listening.

2. Speaker

As the output impedance is 4 ohms, a speaker impedance close to this is recommended.

For headphone use, connect the leads to the plug supplied. Low impedance, 4 - 16 ohms, headphones should be used.

AM RECEPTION

Position of Controls

Mode Switch:	AM
Preselector:	Set to noise peak
Band:	Desired Band
RF GAIN:	Maximum
AF GAIN:	For suitable volume
ANL:	Off
CALIB:	Off
Monitor:	Minimum position
AGC:	Fast
CH-select:	VFO

Main dial may be accurately set for each band at the 100 kHz points with the aid of a crystal calibrator and adjusting the zero set control to zero beat.

Turn the main tuning knob to receive the desired signal and adjust for maximum "S" meter reading, then peak with pre-selector. When impulse noise such as generated by auto ignition systems is strong switch on ANL. The tuning knob has 50 graduations, and one revolution of the knob covers about 50 kHz on each band, except 28 MHz where one revolution covers about 100 kHz.

3. SSB & CW Reception

Set knobs to the same position as above, except the mode switch is set to the SSB/CW position.

Tune for maximum "S" meter indication, then adjust BFO PITCH to resolve the SSB signal, or, for CW, to obtain a comfortable listening tone. Most SSB stations use LSB on 80 and 40 meters and

In the case of adjusting while communicating, turn the BFO PITCH to give the same tone from the received signal and monitored signal. Note that the BFO PITCH control can be used to provide a degree of "off-set" tuning in the transceive mode.

ALIGNMENT PROCEDURE

1. Test Equipment Required

- A. Circuit tester
- B. VTVM & RF probe
- C. Standard signal generator (SSG)

{To protect your precious signal generator please make sure you AC couple to the receiver. VTVM refers to a Vacuum Tube Volt Meter - these instruments have an input resistance of around 11 M Ω , most modern Digital Multimeters have a input resistance of 10 M Ω - this will slightly affect the voltage measurements made as per Table 1.}

2. Voltage Measurements {to assist with fault finding}

Use the VTVM to measure voltages. Refer to Table 1 for approximate values. A circuit tester used for measurement will indicate some lower voltages than those shown in the table.

{2bis. Resistance Measurements

To further assist with fault finding Table 2 contains expected resistance measurements between ground and the indicated point in the circuit. These measurements are made with the receiver switched off (and preferably with the plug pulled out of the mains socket)}

3. 455 kHz I.F. Alignment

Apply a 455 kHz signal to grid 1 of V3 (pin 1). Adjust MF1, MF2 and L7 for maximum "S" meter reading. Use care if adjusting MF1, MF2. The adjusting screws have a fine thread and can be easily damaged, if too much pressure is applied. However, re-adjustment of these should not be necessary as there is little to get out of order. *{The filters in my receiver were not adjustable.}*

4. 1st I.F. Alignment

Apply a 173.9 kHz signal to grid 1 of V2 (pin 7). Adjust L6 (both cores) for maximum "S" meter reading.

{L6 on my receiver had only one core and peaked satisfactorily}

5. Adjustment of 2nd Oscillator Output

Connect RF probe of VTVM to grid 1 of V3 (pin 1). Adjust the upper core of L19 for 70% of maximum reading, and the lower core for maximum reading.

6. Alignment of VFO Scale

For correct alignment a 100 kHz marker is necessary, and if this is built-in it should be used. Adjust coils at the low frequency end, and trimmer condensers at the high end of each band for zero beat. Repeat this adjustment for greatest accuracy. Note that turning of cores or trimmers too far may lead to incorrect frequency by an amount of ± 100 kHz.

7. RF Alignment {alignment of the pre-selector}

Set mode switch (S3) to AM, band switch (S1) to 10m, and the preselector (VC1) to mid-scale. With the main dial (VC2), tune in a 28.5 MHz signal from the SSG. Adjust cores of L2 and L4 for maximum "S" meter reading.

Set the band switch to 15m and tune in a 21.25 MHz signal from the SSG, and adjust TC3 and TC8 for maximum "S" meter reading.

On 20 meters, with SSG output 14.25 MHz, adjust TC2 and TC7 for maximum "S" meter reading.

On 40 meters, with SSG output 7.25 MHz, adjust L3 and L5 for maximum "S" meter reading.

On 80 meters, with SSG output 3.5 MHz and preselector (VC1) at "1", adjust TC1 and TC6 for maximum "S" meter reading. On this band, the upper limit of the preselector range is about 3.8 MHz so a slight sensitivity decrease results between 3.8 and 4 MHz.

During the alignment, keep the SSG output level down to the minimum of that required. {at least below -60 dBm}

{TC4 and TC9 are used to adjust the AUX frequency, I have no idea what TC? does}

8. Adjustment of Trap

L1 is a trap to prevent a spurious signal from entering directly into 1st I.F. stage. Set the SSG output on 5 173.9 kHz and adjust L1 for minimum "S" meter reading. Adjust L19 so that no beat is heard from the speaker. This adjustment is unnecessary unless set up for transceive operation.

9. BFO Alignment

Set mode switch (S3) to SSB/CW. Tune receiver to a non-modulated signal from the SSG, adjusting for maximum "S" meter reading. Set BFO PITCH to "0" and adjust L19 for zero beat.

10. "S" Meter Zero Set

After removing antenna, adjust VR3 so that "S" meter indicates zero. Note that the "S" meter will not read inversely due to the installation of a diode. {My receiver as well as the schematics I have seen do not have this diode installed.}

VOLTAGE MEASUREMENTS (Volts d.c.)

TUBE	PIN NUMBER								
	1	2	3	4	5	6	7	8	9
V1	0	# 1.0	0	AC 6.3	145	70	0	/	/
V2	75 ^o	# -3.0 ^o	0	AC 6.3	AC 6.3	40	# -0.4	# 0.3	0
V3	0	# 0.4	0	AC 6.3	80	20	0	/	/
V4	0	0	0	AC 6.3	140	85	# 1.6	/	/
V5	0	0	0	AC 6.3	135	85	# 1.2	/	/
V6	# -0.7 ^Δ	1.5 ^Δ	0	AC 6.3	80 ^Δ	55 ^Δ	0	/	/
V7	0 ^Δ	0	0	AC 6.3	35 ^Δ	35 ^Δ	0.3 ^Δ	/	/
V8	0	7.2	0	AC 6.3	0	140	120	# 0.6	35

Table 1. Voltage measurements.

o = Calibrator switched on

Δ = Mode switch in SSB/CW position

= {no idea and no indication on any of my reference documents}

RESISTANCE MEASUREMENTS (ohms)

TUBE	PIN NUMBER								
	1	2	3	4	5	6	7	8	9
V1	∞	150	/	/	6K	18K	0	/	/
V2	100K ^o	1M	0	/	/	100K	100K	270	0
V3	100K	330	/	/	52K	500K	0	/	/
V4	∞	0	/	/	5K8	30K	180	/	/
V5	∞	0	/	/	5K6	11K5	150	/	/
V6	22K	220	/	/	34K ^Δ	20K ^Δ	4K7	/	/
V7	47K	0	/	/	70K ^Δ	70K ^Δ	220	/	/
V8	500K [•]	220	470K	/	/	3K6	9K5	2K2	300K

Table 2. Resistance Measurements

o = Calibrator switched on

• = Audio gain set to maximum

Δ = Mode switch in SSB/CW position

MAINTENANCE

This receiver has been thoroughly adjusted with the aid of much measuring equipment by the manufacturer, so re-adjustment should not normally be necessary for a long time. If, due to component change or development of some fault, re-adjustment or repair should be found necessary, then this should be attempted only after full understanding of this booklet.

1. Removal of Chassis

After removing the four screws from the underside, push on the front panel and withdraw from the rear.

2. Location of Faults

Measure voltages and make resistance checks using Table 1 and Table 2 for reference. Any large departure from the values shown in the tables could be an indication of the faulty section.

Use the VTVM for checking.

(1) Receiver not operating:-

Examine AC power cord and plug.

Check fuse. If the fuse has gone, there may be a short circuit in the H.T. or heater circuits, or failure of one or more of the silicon diode rectifiers (D5, D6, D7 & D8).

(2) No sound from speaker:-

Examine speaker connections, making sure that the headphone plug is removed from the jack on the front panel.

Check audio amplifier section by touching grid of V8 with a screwdriver.

Check detector stages.

AM --- detector diode (D4)

SSB --- BFO and product detector

(3) Audio and detector stages OK but receive fails to operate:-

In checking IF and RF stages make use of the "S" meter.

Examine the 1st converter if the receiver fails only on one band.

If click is apparent when grid of V3 is touched with a screwdriver, fault is in the stages preceding V3.

Local oscillator injection voltage must be measured with the VTVM.

NOTE - Dial Calibrations

On the main dial, the bottom scale is for 80 meters. "500" represents 3 500 kHz, "600" represents 3 600 kHz, and so on.

The centre scale serves for the 40, 20 and 15 meter bands where "0" represents 7 000, 14 000 or 21 000 kHz, "100" represents 7 100, 14 100 or 21 100 kHz, etc., depending on the band in use.

The sub-divisions on the main dial are 10 kHz points. The graduations on the tuning knob skirt closely represent 1 kHz divisions. The upper scale on the main dial is used for 10 meters but in this case the knob skirt graduations represent 2 kHz divisions.

The knob skirt may be adjusted independently of the knob itself by firmly holding the knob while turning the skirt, and can be set at 0 for 100 kHz points with a crystal calibrator. Since, on all bands except 10m, the knob rotates two full turns for each 100 kHz segment, a double numbering system is adopted on the skirt, thus, read 0 to 49 kHz using the black numbers and 50 to 100 kHz using the red numbers.

A plug-in 100 kHz crystal is available as an optional extra.

PART LOCATIONS

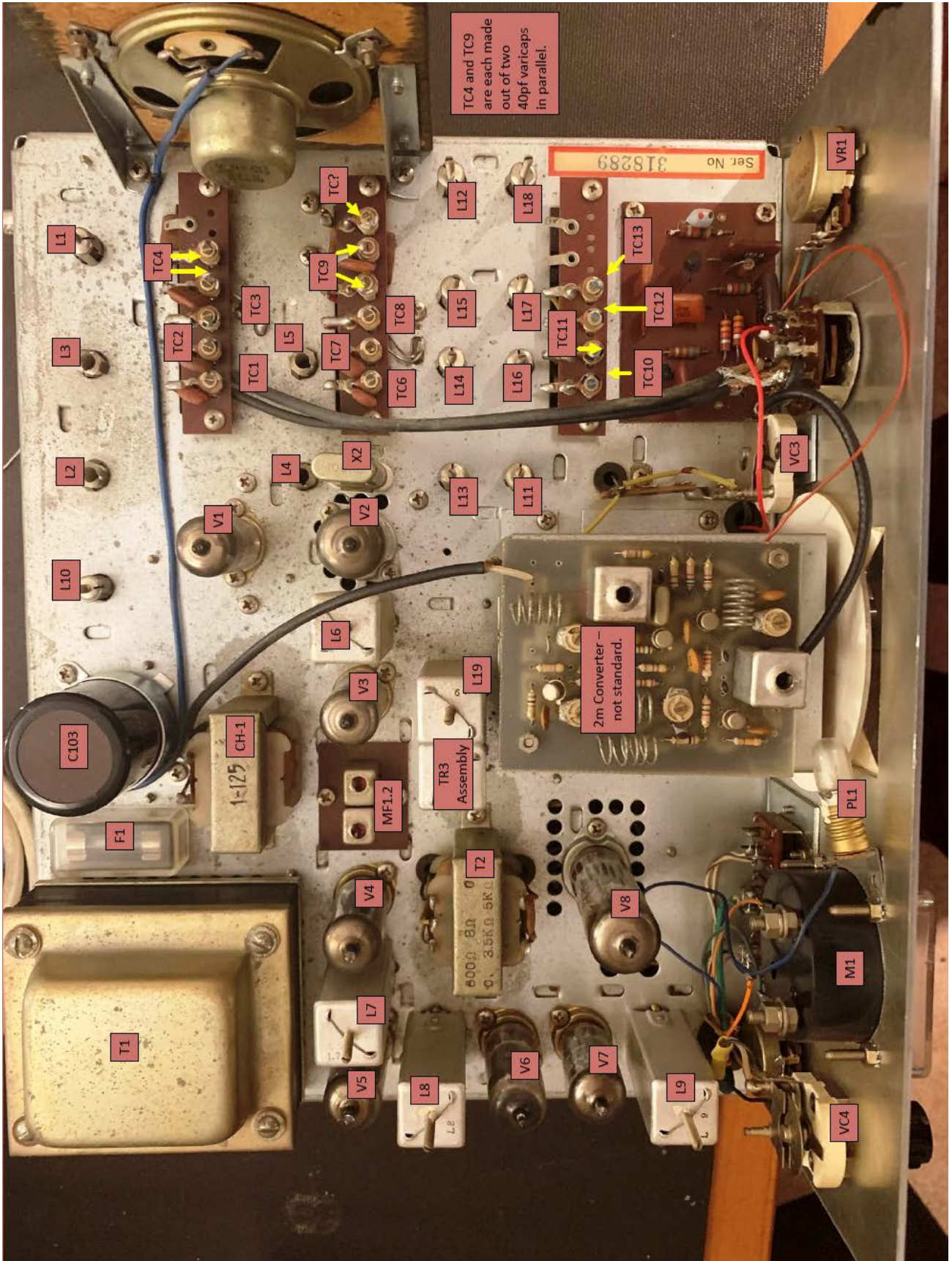

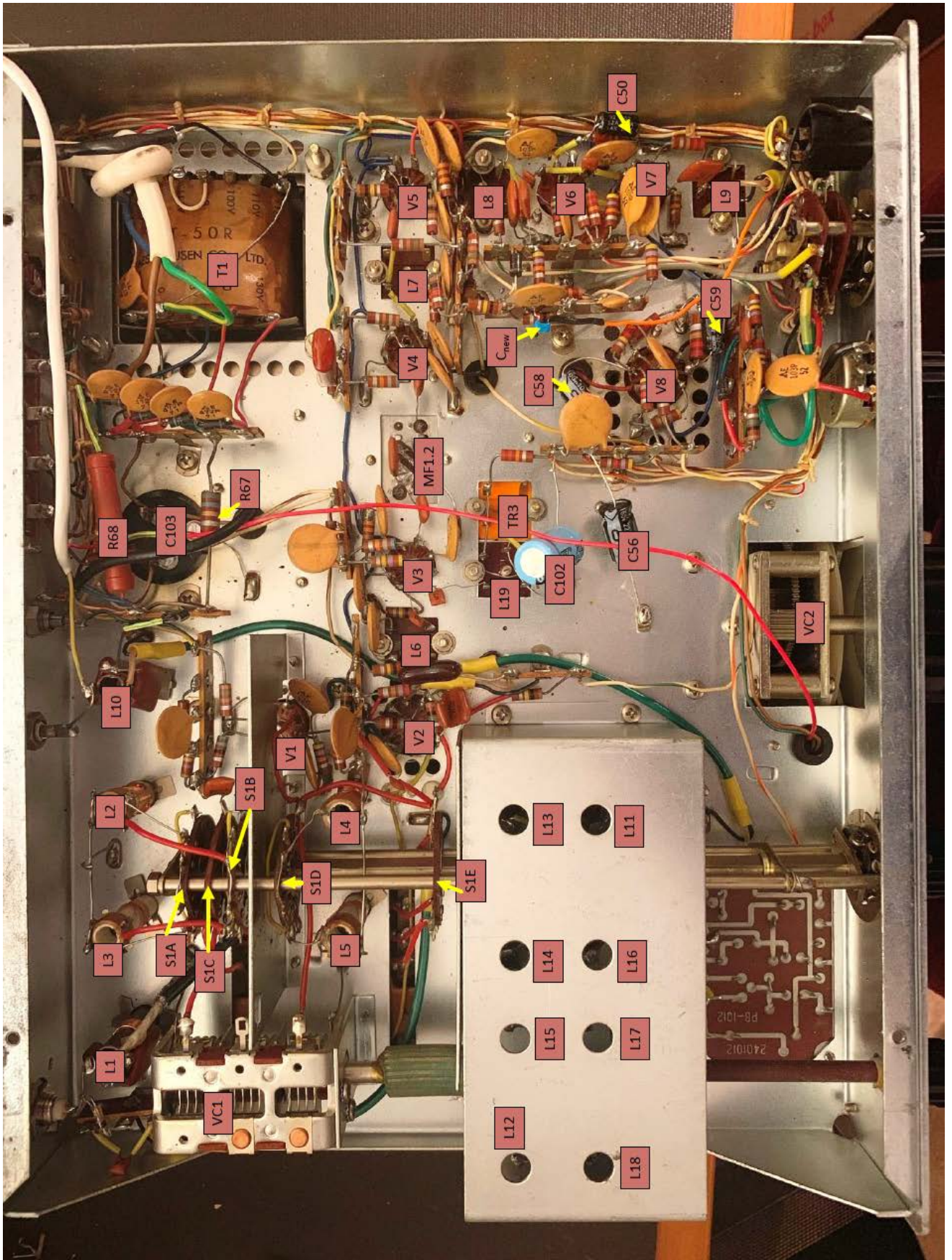

CIRCUIT DIAGRAMS

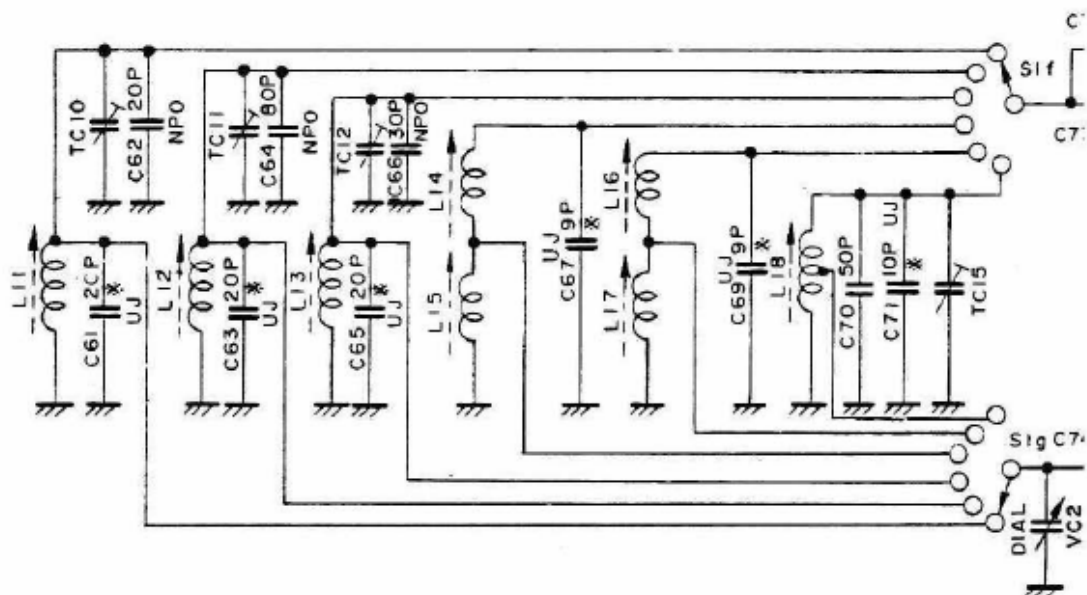
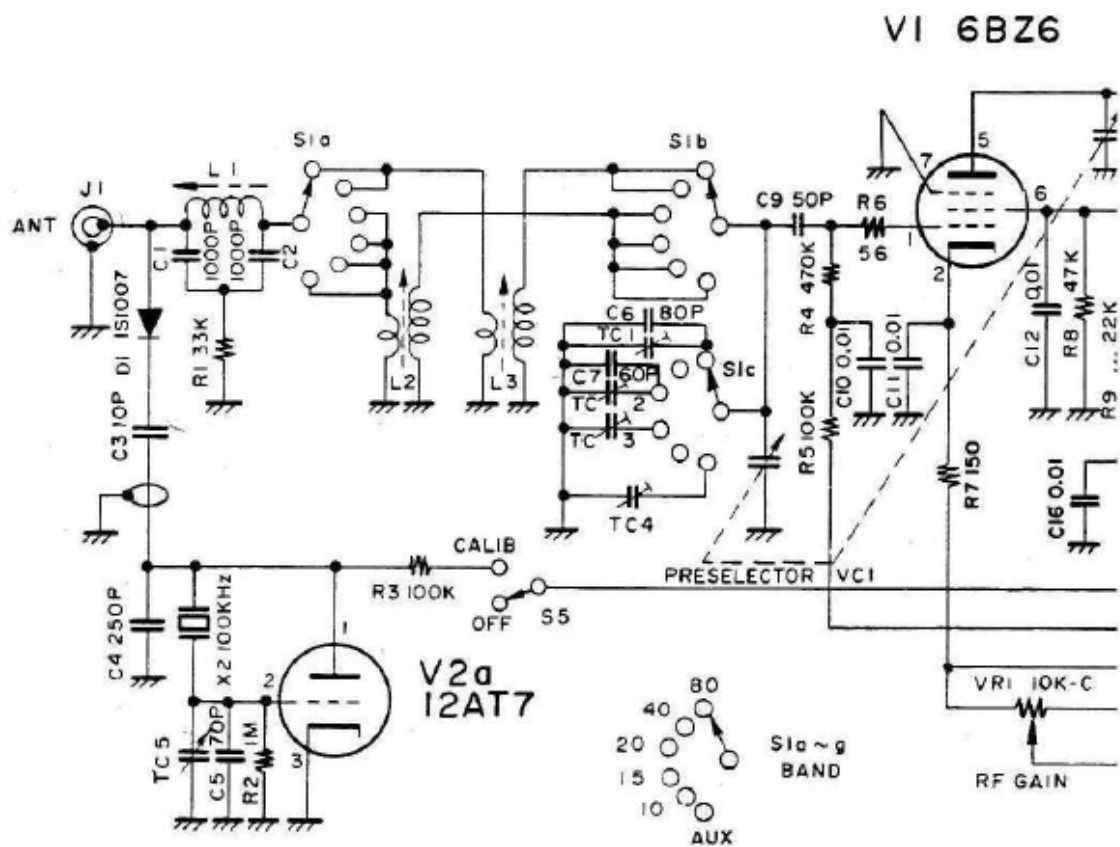

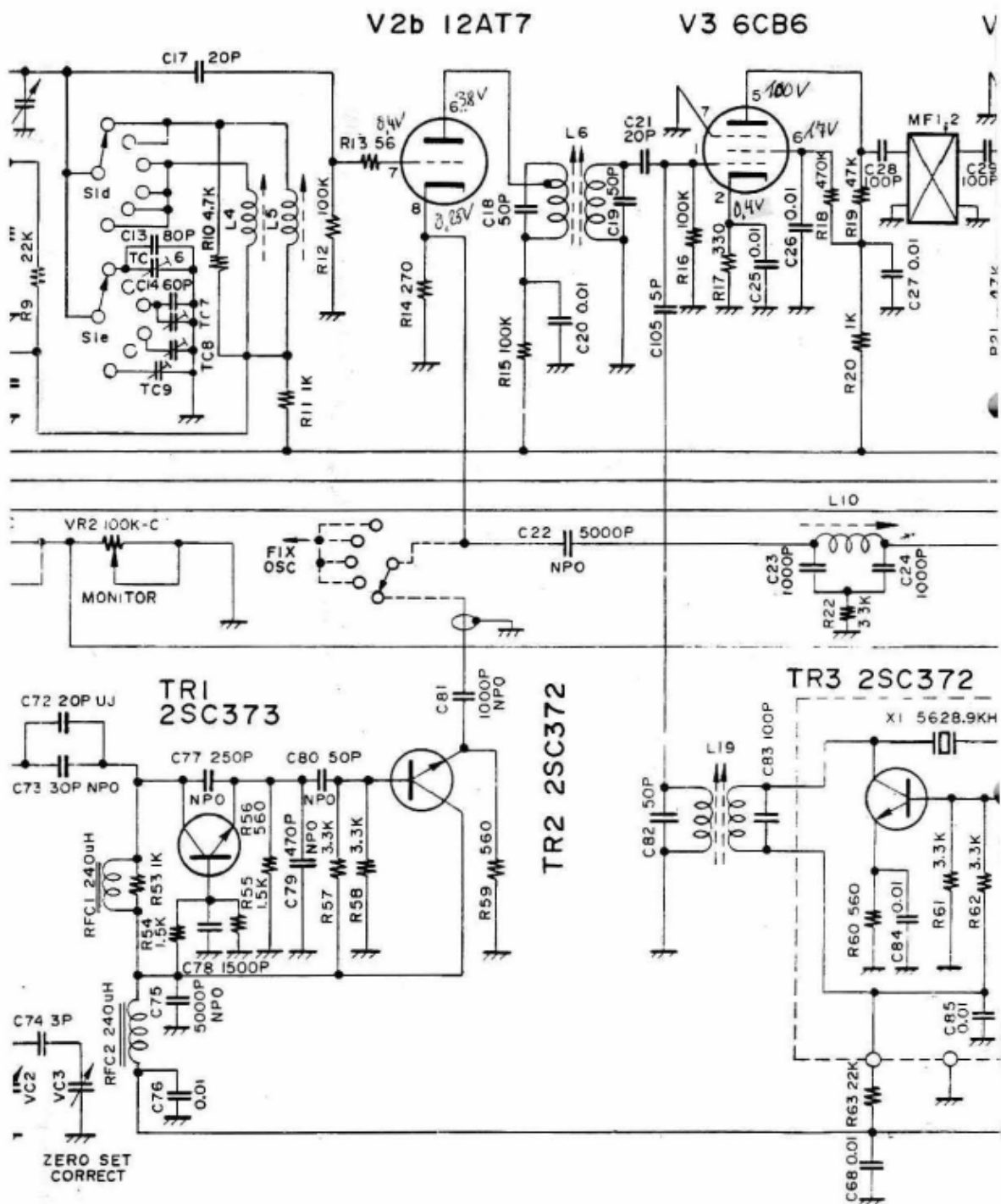

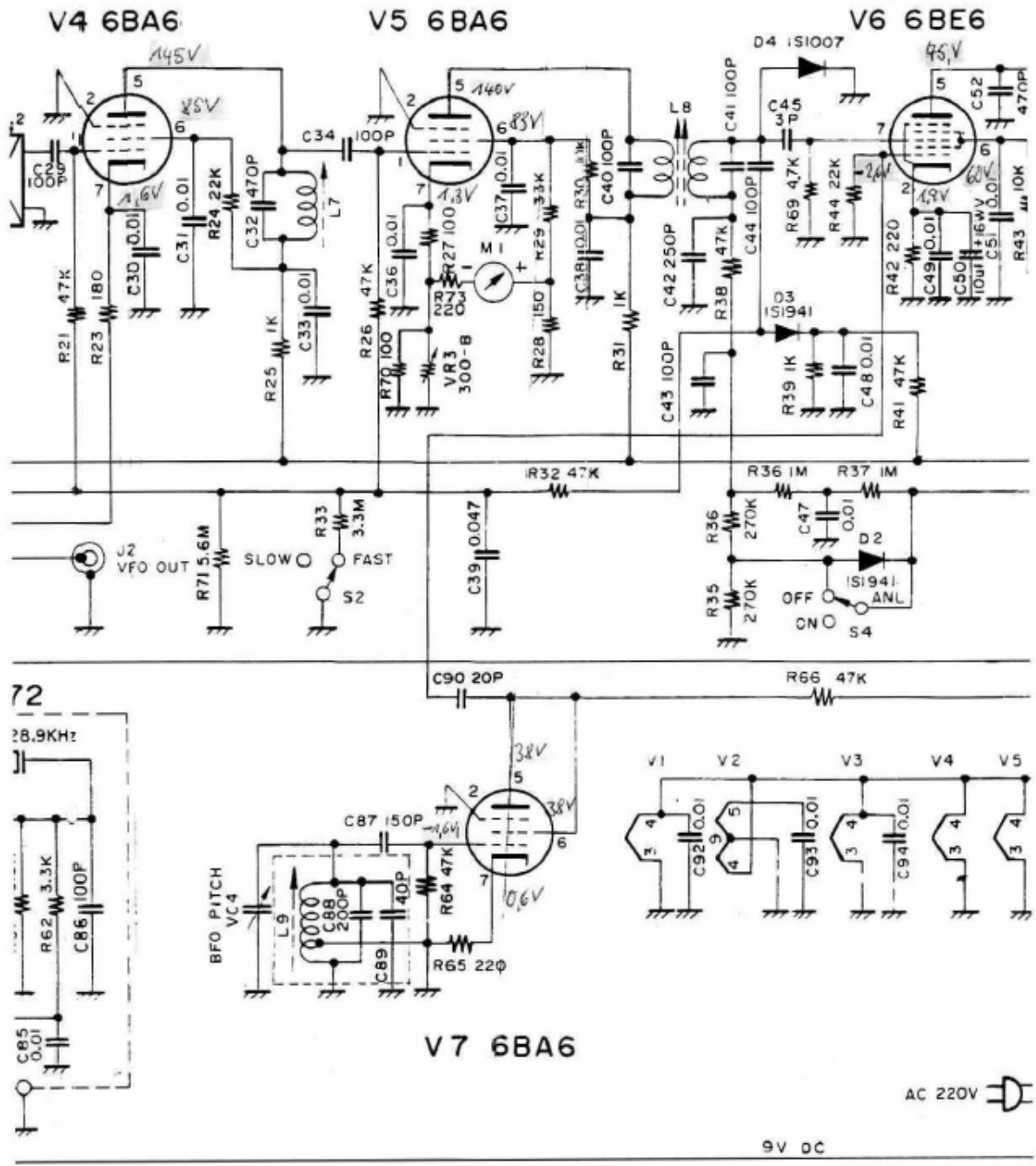

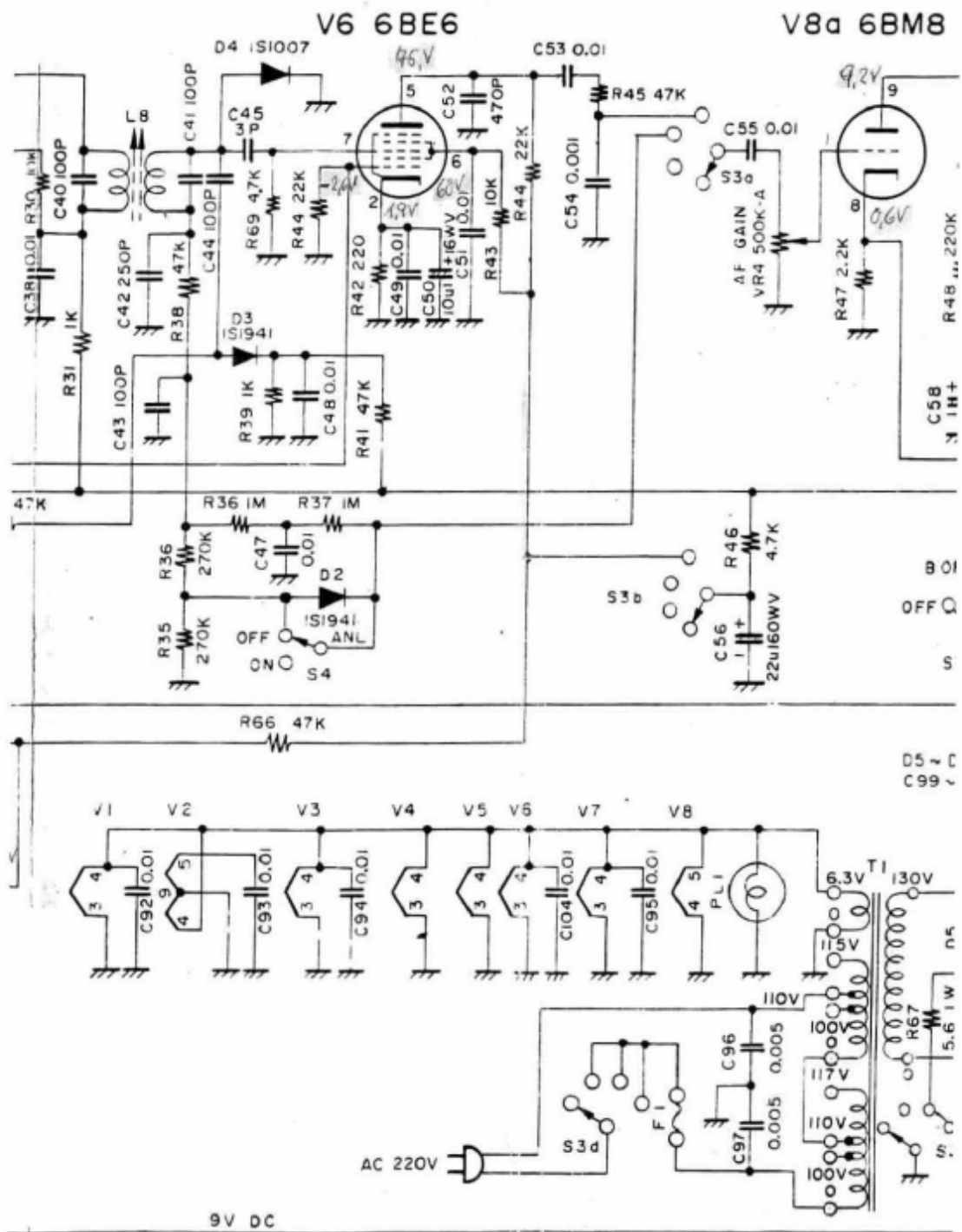

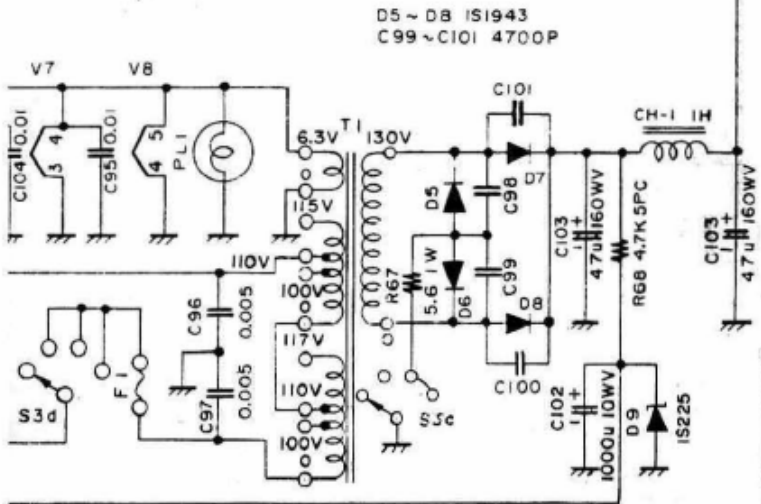
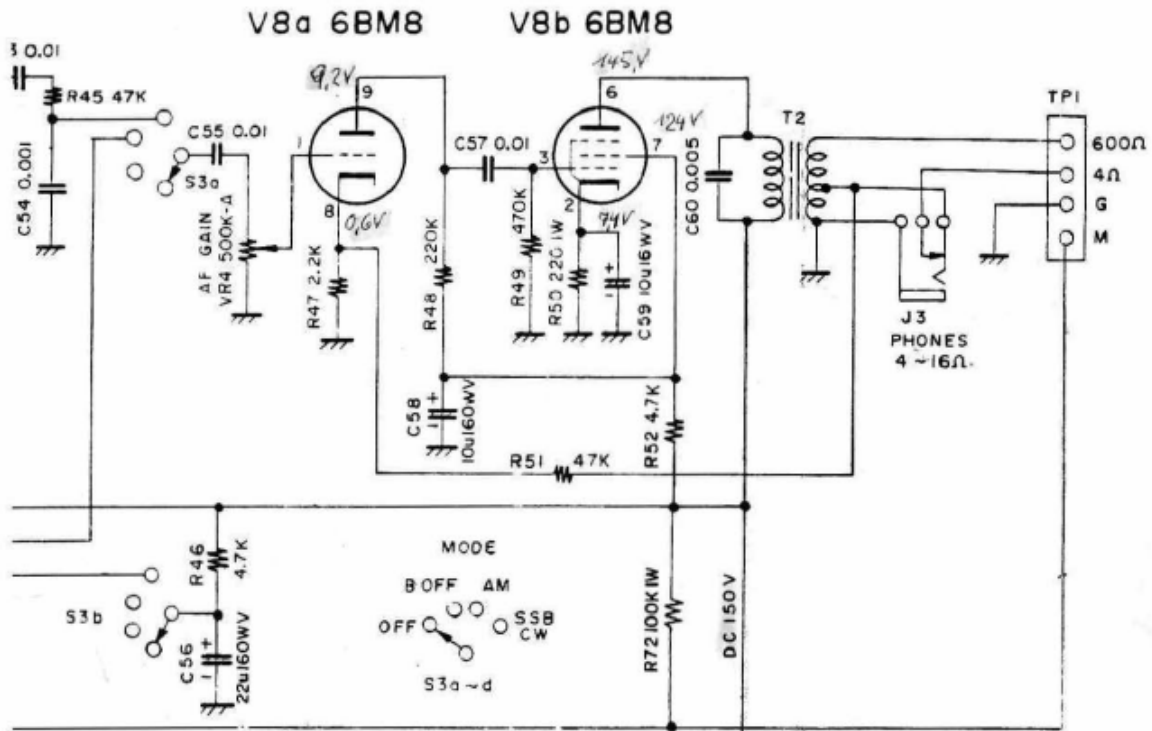

- NOTES:
1. ALL RESISTOR IN OHM 1/2W ±10 UNLESS OTHERWISE NOTED.
 2. CAPACITOR IN uF UNLESS OTHERWISE NOTED.
 3. * VALUE IS NOMINAL.

FR-50B
CIRCUIT DIAGRAM

{This page is set to print landscape A3}

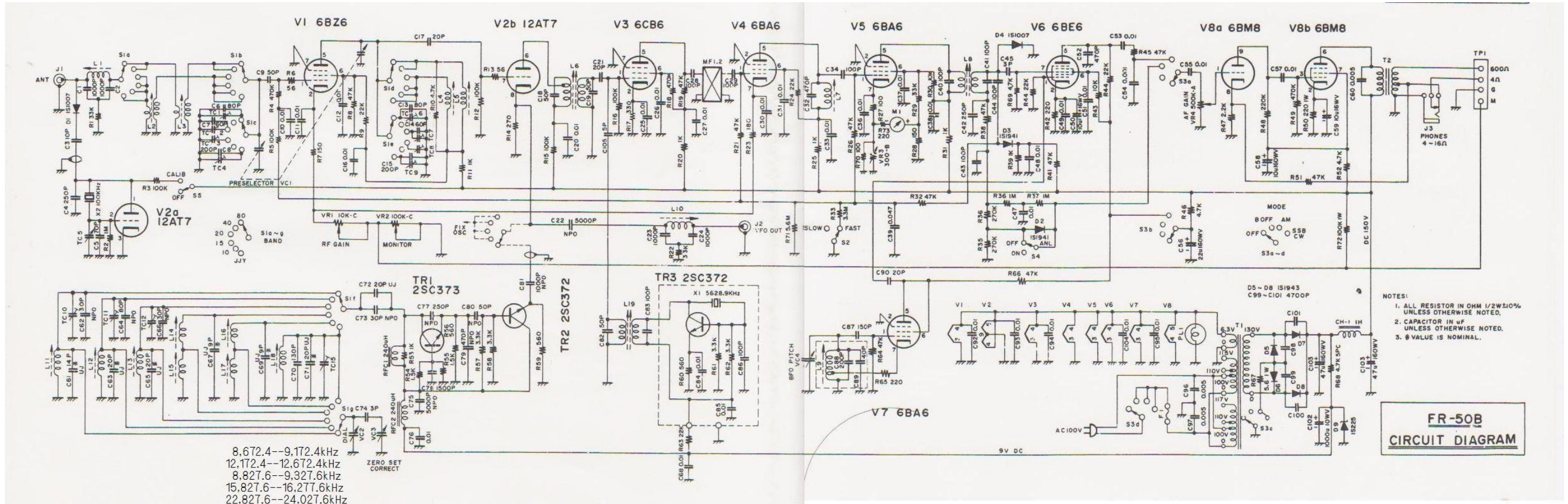

{This page is set to print landscape on a piece of paper 54cm wide by 25cm high}

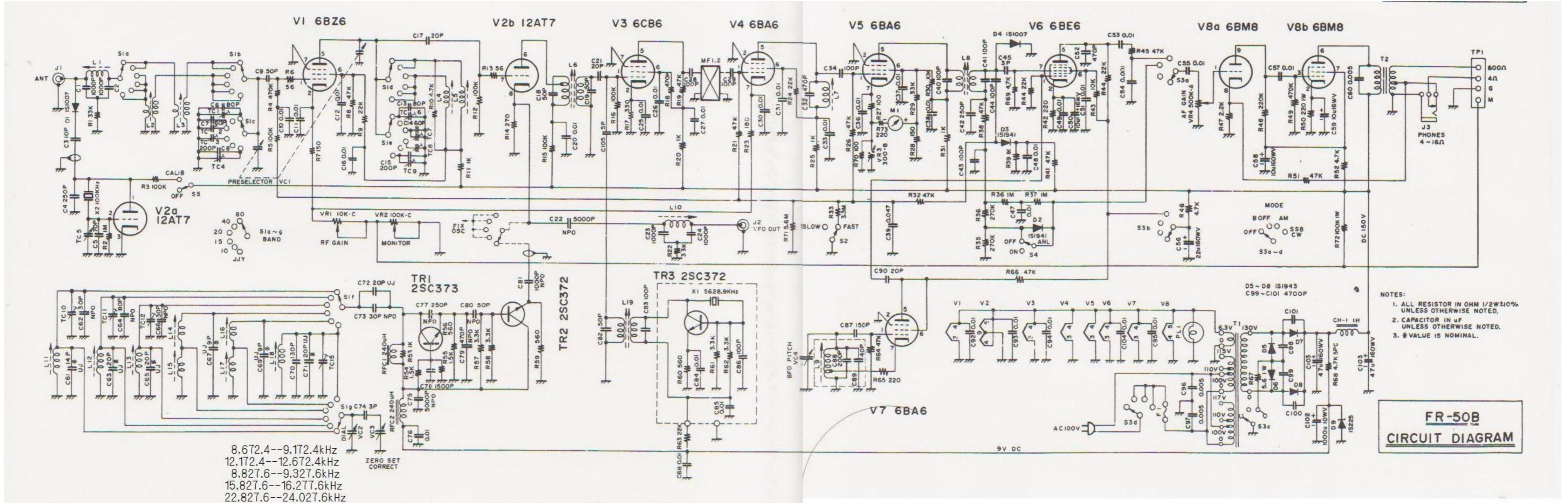

8,672.4--9,172.4kHz
 12,172.4--12,672.4kHz
 8,827.6--9,327.6kHz
 15,827.6--16,277.6kHz
 22,827.6--24,027.6kHz