

**INSTRUCTION**

**MANUAL**

**FT-227RB**

**YAESU MUSEN CO , LTD.**

TOKYO JAPAN.

## TABLE OF CONTENTS

	(Page)
INTRODUCTION .....	1
SPECIFICATIONS .....	2
CONTROLS AND SWITCHES .....	3
REAR APRON .....	5
INSTALLATION .....	7
OPERATION .....	9
BLOCK DIAGRAM .....	11
THEORY OF OPERATION.....	12
MAINTENANCE AND ALIGNMENT .....	19
PARTS LIST .....	26

# SPECIFICATIONS

## GENERAL

**Frequency Coverage**  
144 to 148 MHz

**Number of Channels**  
800 channels

**Speaker**  
Internal 3" dynamic speaker with provision for connecting an external 8 ohm dynamic speaker.

**Microphone**  
Dynamic push-to-talk microphone with retractable coiled cord. Impedance is 600 ohms.

**Power Requirement**  
13.8 Volts DC,  $\pm 10\%$ .

**Current Consumption**  
0.5 Amps Receive.  
2.5 Amps Transmit.

**Metering**  
Illuminated front panel meter indicates relative received signal strength and transmitter power output.

**Dimensions**  
180 (W) x 60 (H) x 220 (D) mm

**Weight**  
2.7 kg.

## TRANSMITTER

**RF Output**  
10 Watts into 50 ohm load at 13.8 Volts DC

**Frequency Stability**  
 $\pm 0.002\%$ .

**Modulation**  
F3.

**Deviation**  
 $\pm 5$  kHz.

**Audio Response**  
 $+1, -3$  dB of 6 dB/Octave pre-emphasis characteristic from 300 to 2500 Hz.

**Spurious Emissions**  
60 dB below carrier minimum

**Tone Burst.**  
Nominally one second at 1800 Hz.

**Repeater Split.**  
 $\pm 600$  kHz or any frequency in 5 kHz increments

## RECEIVER

**Type**  
Double conversion super-heterodyne

**Intermediate Frequency**  
10.7 MHz first IF; 455 kHz second IF

**Sensitivity**  
0.3  $\mu$ V for 20 dB quieting.

**Selectivity**  
 $\pm 6$  kHz at 6 dB:  $\pm 12$  kHz at 60 dB

**Audio Output**  
1.5 Watts at 8 ohms

SPECIFICATIONS SUBJECT TO CHANGE WITHOUT NOTICE

## CONTROLS & SWITCHES

The FT-227RB has been designed for ease of operation. However, the operator may not be familiar with some controls, since it utilizes

modern computer technology. Be sure you thoroughly understand the function of each control and indicator before operating the equipment.

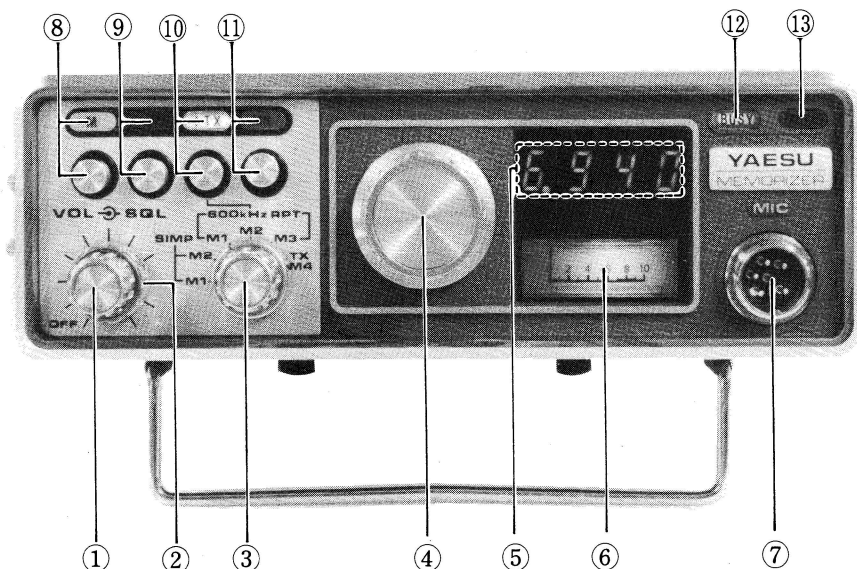

### (1) Vol inner control

The VOLUME control adjusts the receiver audio output level and turns power off when rotated to and extreme CCW position.

### (2) SQL Outer control

The SQUELCH control adjusts the receiver squelch threshold sensitivity.

### (3) FUNCTION switch

This switch selects the transmit frequency. Positions M1 and M2 (SIMP) can be used for simplex operation. Positions M1–M3 can be used for  $\pm 600$  kHz split, for repeater operation. M4 is used for programming an auxiliary split of up to 4 MHz. Refer to the section on operation for details.

### (4) Channel Selector

Endless optical coupling selects 800 channels.

### (5) DIAL Display

The digital display indicates the operating frequency.

### (6) METER

The meter indicates the signal strength on receiver and the relative power output on transmit.

### (7) MIC receptacle

Four pin connector is used for microphone input and push-to-talk relay actuation.

### (8) MEMORY switch

When pressed, the frequency on the dial is memorized, and the M lamp lights up. To release the memorized frequency, press the switch a second time.

### (9) SUP switch

The channel frequency shifts 5 kHz up, and the SUP lamp lights up.

### (10) +TX

This switch is used to select the direction of the repeater split. When the switch is not pushed, repeater split of  $-600$  kHz is selected. With the switch pushed, repeater split of  $+600$  kHz is selected. Refer to the section on repeater operation.

### (11) MEMORY RECALL switch

When switch is pressed, the memorized frequency is recalled, and the MR lamp lights up.

### (12) BUSY indicator

The lamp lights up when a signal is received.

### (13) ON AIR indicator

The lamp lights up when in the transmit mode.

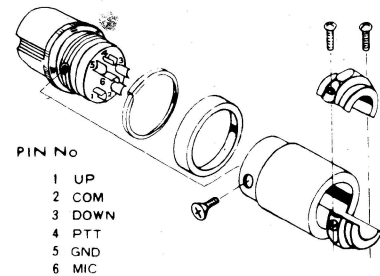
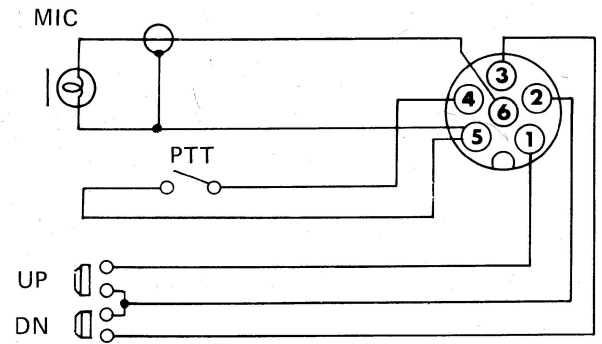

Figure 1  
Microphone Connections

## CABINET BOTTOM

### (1) BURST

When this switch is in the ON position, a short duration audio tone of  $1800$  Hz will be superimposed on the transmitted signal. This is normally used only with repeaters requiring tone access.

### (2) BUSY/MAN/CLEAR

This switch selects the mode of the PLL scanner. In the BUSY position, the scanner will search until it finds an occupied channel (one containing a signal strong enough to trip the FT-227RB squelch). In the MAN position, scanner stop commands come exclusively from the microphone. In the CLEAR position, the scanner will search until it finds a channel which has no signal present.

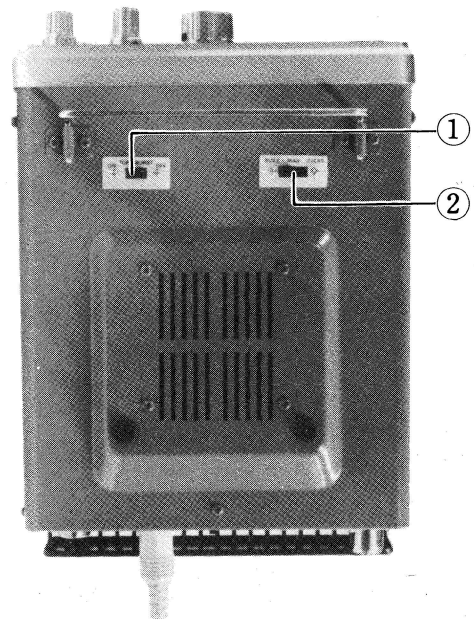

## REAR PANEL

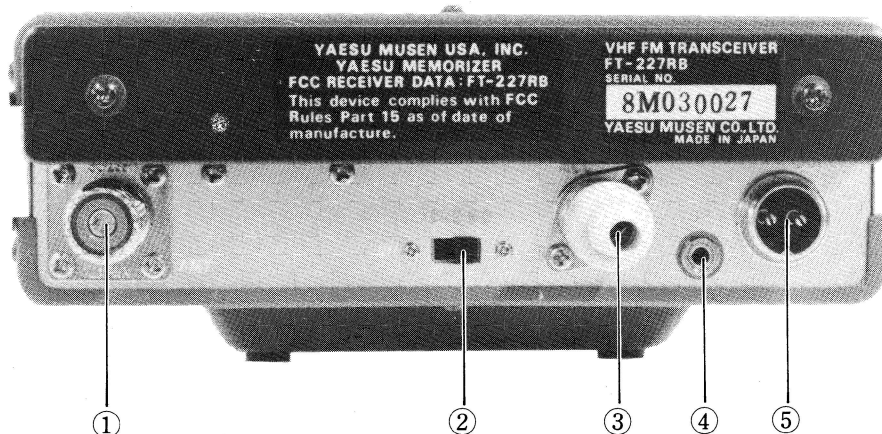

### (1) ANT receptacle

UHF type coaxial receptacle for connection of antenna.

### (2) TONE SQUELCH switch

An optional TONE SQUELCH circuit is activated when switch is placed in ON position.

### (3) ACC socket

The ACCESSORY socket is used for external control of the transceiver.

### (4) SP receptacle

Audio output is provided at this receptacle for an external speaker. (Output impedance is 8 ohms, and the internal speaker will be disabled when a plug is inserted.)

### (5) POWER receptacle

A two-pin connector is used for connection to 13.8 Volt DC (negative ground) power source, vehicle battery, or AC power supply.

## ACCESSORIES

The following accessories are included with this transceiver:

1. Dynamic microphone with retractable, coiled cord.
2. Mobile mounting bracket with hardware.
3. DC power cable.
4. Cigarette lighter adapter.
5. Spare fuses.
6. Microphone hanger.
7. Miniature phone plug for external speaker.
8. Accessory plug (must be inserted in rear of transceiver at all times).
9. Tap connector.

## CAUTION

IMPROPER FUSE REPLACEMENT CAN CAUSE PERMANENT DAMAGE IN THE EVENT OF UNUSUAL OPERATING CONDITIONS. OUR WARRANTY DOES NOT COVER DAMAGE CAUSED BY IMPROPER FUSE REPLACEMENT. USE ONLY A 3 AMPERE FUSE.

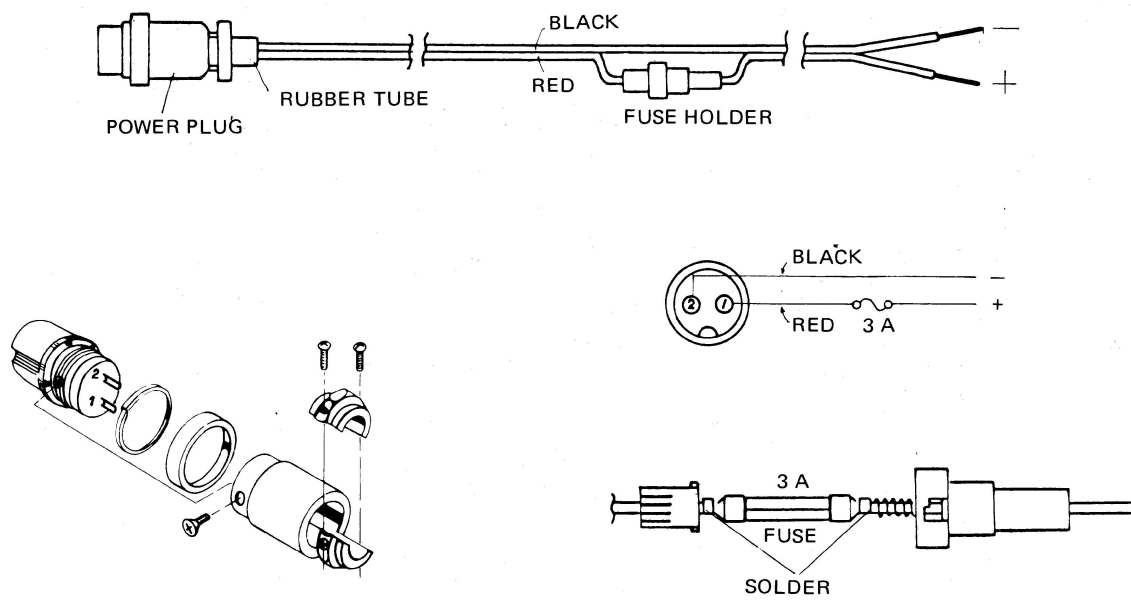

Figure 2.  
POWER CABLE CONNECTIONS

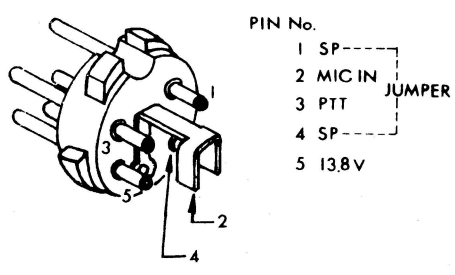

Figure 3.  
ACC (TONE IN) PLUG CONNECTIONS

# INSTALLATION

The FT-227RB transceiver is designed primarily for mobile service, requiring only an antenna and 13.8 volt DC power source for operation. The transceiver has been pre-tuned at the factory, and requires no further adjustment for normal operation into a 50 ohm load.

Under no circumstances should the power cable ever be connected to AC power. **OUR WARRANTY DOES NOT COVER DAMAGE CAUSED BY APPLICATION OF AC POWER TO THE POWER JACK ON THE REAR APRON OF THE TRANSCEIVER.**

## ANTENNA CONSIDERATIONS

In antenna installations, it is desirable that the antenna be located as high and in the clear as possible. In addition, be certain that the SWR on the feedline is less than 1.5 : 1. A higher SWR may cause a reduction in power output, because of the protective circuitry incorporated in design. As well, high SWR will increase the feedline losses.

In all installations, do not economize on coaxial cable. For mobile applications, in which the feedline length is 20 feet or less, type RG-58A/U cable is satisfactory, and the foam types are preferred, because of their lower loss. For base station systems, type RG8A/U may be used for moderate lengths; for very long cable installations, we recommend the use of type RG-17A/U, air-dielectric "heliac" cable, or aluminum-jacketed "foamflex" coax. Beware of "bargain" coax, as the shield coverage may be very poor, and this can seriously degrade system performance.

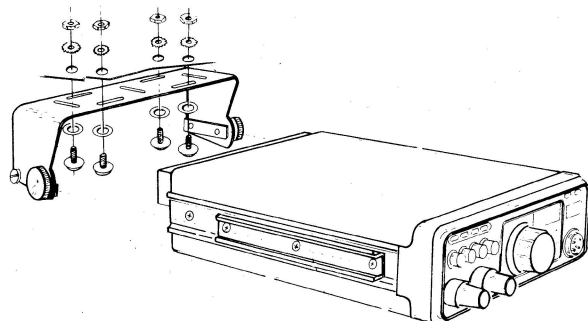

Figure 4 A.

## BASE STATION INSTALLATION

As base station, the FT-227RB requires a power source of 13.8 volts DC at 2.5 amperes. A base station stand is included with your transceiver, for easy viewing.

## MOBILE INSTALLATION

For mobile service, the FT-227RB may be installed where the controls, indicators, and microphone are easily visible and accessible for operation. The unit may be mounted in any position without loss of performance. Suitable locations are atop the transmission tunnel, under the dash, etc. A universal bracket is supplied with the transceiver for this purpose. Install the FT-227RB as follows (refer to Figure 4):

1. Use the universal mounting bracket as a template to locate the mounting holes. Use a 3/16" diameter drill bit for these holes, and allow clearance for the transceiver, its controls, and all connecting cables. Secure the mounting bracket with the screws, washers, and nuts supplied, as shown in Figure 4A.
2. Install the transceiver in the mounting bracket, sliding it into the guide rail of the bracket. Tighten the screws on both sides.
3. The microphone hanger may be affixed in any convenient place for handling the microphone.

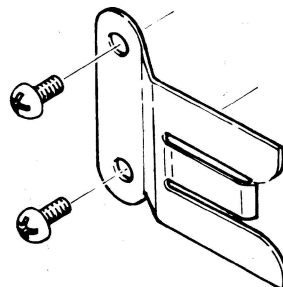

Figure 4 B.

4. The supplied power cable may be plugged directly into the vehicle's cigarette lighter receptacle, for casual use. For permanent installation, the lighter plug may be removed, and the leads routed directly to the battery (red to positive, black to negative or ground). Alternatively, the power leads may be routed to the nearest power terminal, e.g. ignition switch, fuse block, etc. If it is necessary to extend the power leads, use the shortest length possible, and use only #16 AWG insulated copper wire (or larger) to avoid excessive voltage drop.

**CAUTION**

BEFORE CONNECTING THE POWER CONNECTOR TO THE TRANSCEIVER, CHECK THE BATTERY VOLTAGE WITH THE ENGINE RUNNING (BATTERY CHARGING). IF THE VOLTAGE EXCEEDS 15 VOLTS DC, THE VEHICLE VOLTAGE REGULATOR SHOULD BE ADJUSTED TO PROVIDE A MAXIMUM CHARGING RATE OF LESS THAN 15 VOLTS DC. ALSO, BE CERTAIN TO OBSERVE PROPER POLARITY WHEN MAKING BATTERY CONNECTIONS. THE RED LEAD IS CONNECTED TO THE POSITIVE BATTERY TERMINAL, WHILE THE BLACK LEAD IS CONNECTED TO THE NEGATIVE TERMINAL. REVERSED POLARITY WILL NOT DAMAGE THE FT-227RA, BECAUSE OF THE PROTECTIVE CIRCUITRY INCORPORATED; HOWEVER, THE TRANSCEIVER WILL NOT OPERATE UNDER THESE CONDITIONS.

5. Connect the power cable to the POWER receptacle on the rear panel of the transceiver.
6. Connect the 50 ohm antenna cable to the ANT receptacle on the rear apron of the transceiver.
7. Connect the microphone cable to the 6-pin microphone receptacle on the front panel of the transceiver.
8. An external 8 ohm speaker may be connected at the SP receptacle on the rear panel, if desired. This will automatically disconnect the internal speaker. Use the external speaker plug supplied.

**HOW TO USE THE TAP CONNECTOR**

- (a) Do NOT strip insulation from wires.
- (b) The tap connector will handle most wire sizes used in automotive instrument panels.
- (c) Slice the "hot" lead into tap connector as shown.
- (d) Insert transceiver power lead 3/4 of the way into connector (just past metal connector element).
- (e) Using pliers, press the metal connector element until it is FLUSH.
- (f) Fold the hinged cover over the connector element and snap firmly in place.

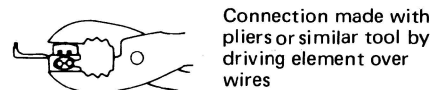
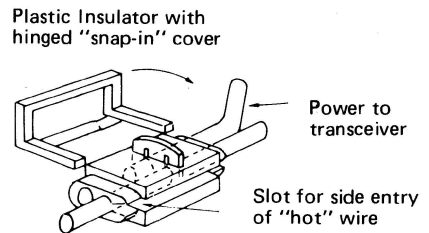

Self-stripping "U" type spring pressure connector element

Figure 5

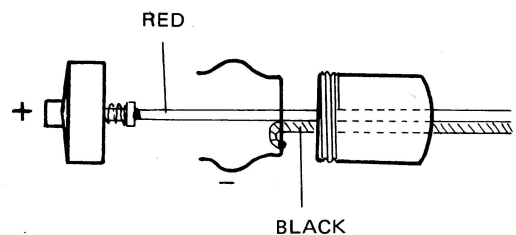

Figure 6

# OPERATION

## INITIAL CHECK

1. Rotate the VOLUME control in a clockwise direction to apply power. The meter will become illuminated, and the digital display will indicate "7.000" initially ("5000" on models limited to 144–146 MHz). With the 5 UP button pressed, the display will indicate "7.005" ("5.005").
2. Rotate the SQUELCH control fully counterwise.
3. Adjust the VOLUME control for a normal listening level on an incoming signal or the background noise.
4. Rotate the main tuning dial to find a clear channel (background noise only). Advance the SQUELCH control clockwise until the receiver is just silenced and the BUSY lamp turns off. Perform this step carefully so as not to go beyond the threshold point; if you do, the receiver will not respond to weak signals.

## FREQUENCY SELECTION

The channel selection knob selects the operating frequency in 10 kHz steps. Clockwise rotation of the main dial increases the frequency up to 148.000 MHz, while counterclockwise rotation lowers the frequency to 143.990 MHz. On 143.990 and 148.000 MHz, the transmitter is disabled, preventing out-of-range operation. This protection applies, as well, to memorized frequencies, in addition to dial frequencies.

### CAUTION

CHANNEL SELECTION MUST NOT BE MADE WHILE THE PUSH-TO-TALK SWITCH IS ACTIVATED FOR TRANSMISSION.

## SCANNER OPERATION

The PLL scanner will allow remote scanning for easy frequency change. Set the BUSY/MAN/CLEAR switch to MAN. Now, pressing the UP switch on the microphone for an instant will shift the operating frequency up 10 kHz. Pressing the DN switch will, likewise, lower the operating frequency 10 kHz.

Now, press the UP switch, and hold it in the depressed position. After an initial shift of 10 kHz, and a delay of approximately 1 second, the scanner will be activated, and the frequency will be shifted rapidly upward until the UP or DN switch is pressed again, at which time the scan will be halted. When the upper band edge is reached, the scan will reverse itself, and will begin scanning in a lower direction.

The same relations apply when the DN switch is pressed, except that when the lower band edge is reached, the scanner will reverse itself and begin scanning upward.

To set the scanner for searching for an occupied channel, set the BUSY/MAN/CLEAR switch to BUSY. Now, when the scanner is activated, the scan will be halted whenever the squelch is activated by an incoming signal. If the squelch is not adjusted to silence the receiver (with no signal present), the scanner will advance only 10 kHz per press, thinking that an occupied channel has been found.

To set the scanner for searching for a clear channel, set the BUSY/MAN/CLEAR switch to CLEAR. Now, the scanner will halt when the squelch is silenced (no signal present).

Whether in the BUSY, MAN, or CLEAR modes, the scan may be halted at any time by pressing either the UP or DN switches while scanning. If the PTT switch is pressed while scanning, the scan will be halted and transmission will occur on the frequency on which the scan was halted.

## MEMORY OPERATION

Select the channel desired with the main dial or scanner controls. Set the FUNCTION switch to M1 (SIMP), and press the M (Memory) switch. Now the frequency on the dial is memorized, and both TX and RX will occur on the memorized frequency. For instant recall to the memorized frequency, press MR (Memory Recall). In like fashion, another frequency may be memorized for simplex operation, by setting the FUNCTION switch to M2 (SIMP), and pressing the M button.

Rotation of the FUNCTION switch to positions M1–M3 (600 kHz RPT) automatically shifts the transmit frequency 600 kHz down from the memorized frequency. For example, if you memorize 146.940 MHz in the M1 (SIMP) position, you will be operating transceive on that frequency. Now, rotate the FUNCTION switch to M1 (600 kHz RPT). You will be transmitting on 146.340 MHz, while receiving on 146.940 MHz. By pressing the +TX button, you will be transmitting 600 kHz **above** the receiving frequency, i.e. 147.540 MHz.

The M4 position may be used for split frequency operation, with a split of up to 4 MHz possible. Rotate the main dial or scan to the desired transmit frequency, and press the M button. Now rotate the dial or scan to the desired receive frequency. You will transmit on the memory frequency, while receiving on the dial frequency. The position of the MR button is not important in the case of the MR position of the FUNCTION switch.

## REPEATER OPERATION

A frequency shift of 600 kHz will be applied to the dial frequency when the FUNCTION switch is placed in the 600 kHz RPT position.

When the FUNCTION switch is set to positions M1–M3 (600 kHz RPT), and the MR switch is not pushed, automatic split of –600 kHz will be applied to the dial frequency. With the FUNCTION switch set to M1–M3 (600 kHz RPT), and the MR switch **pushed**, the –600 kHz split will be applied to the memorized frequency.

When operating in the repeater mode, the repeater shift may be made +600 kHz, by pressing the +TX button.

Be careful not to transmit outside the amateur band when using the repeater shift feature.

Remember: placing the FUNCTION switch in the M1–M2 (SIMP) position will provide simplex operation.

When the BURST switch on the bottom of the transceiver is placed in the ON position, a tone of 1800 Hz of approximately 1 second duration will be superimposed on the speech signal. This tone is normally used only with “tone access” repeaters, and the BURST switch should be turned OFF when using repeaters not requiring this access tone.

## OPTIONAL TONE SQUELCH OPERATION

The tone squelch option allows silent monitoring of busy channels. When the tone squelch unit is installed, and the TONE SQ button pushed, a sub-audible tone will be superimposed on the transmitted signal. On receive, the squelch will not open unless a subaudible tone is superimposed on the transmitted signal of the other station. The tone frequency can be set to any frequency between 70 and 250 Hz, as shown in the Alignment section of this manual.

To install the tone squelch option, remove the transceiver from its case. Locate the space provided for the tone squelch circuit board, and align the board so that it fits down over the pins, as shown. Solder the connections shown, and remove the red jumper wire shown in the illustration.

With the tone squelch option installed, the BUSY lamp will light up when **any** signal is received, but the squelch will open only when a subaudible tone is received on an incoming signal. The operator should check the BUSY lamp before transmitting, out of courtesy to other operators who may be using the channel. The tone squelch system is designed to allow silent monitoring of busy channels; it is **not** designed to allow two operators so equipped to have priority use of a channel.

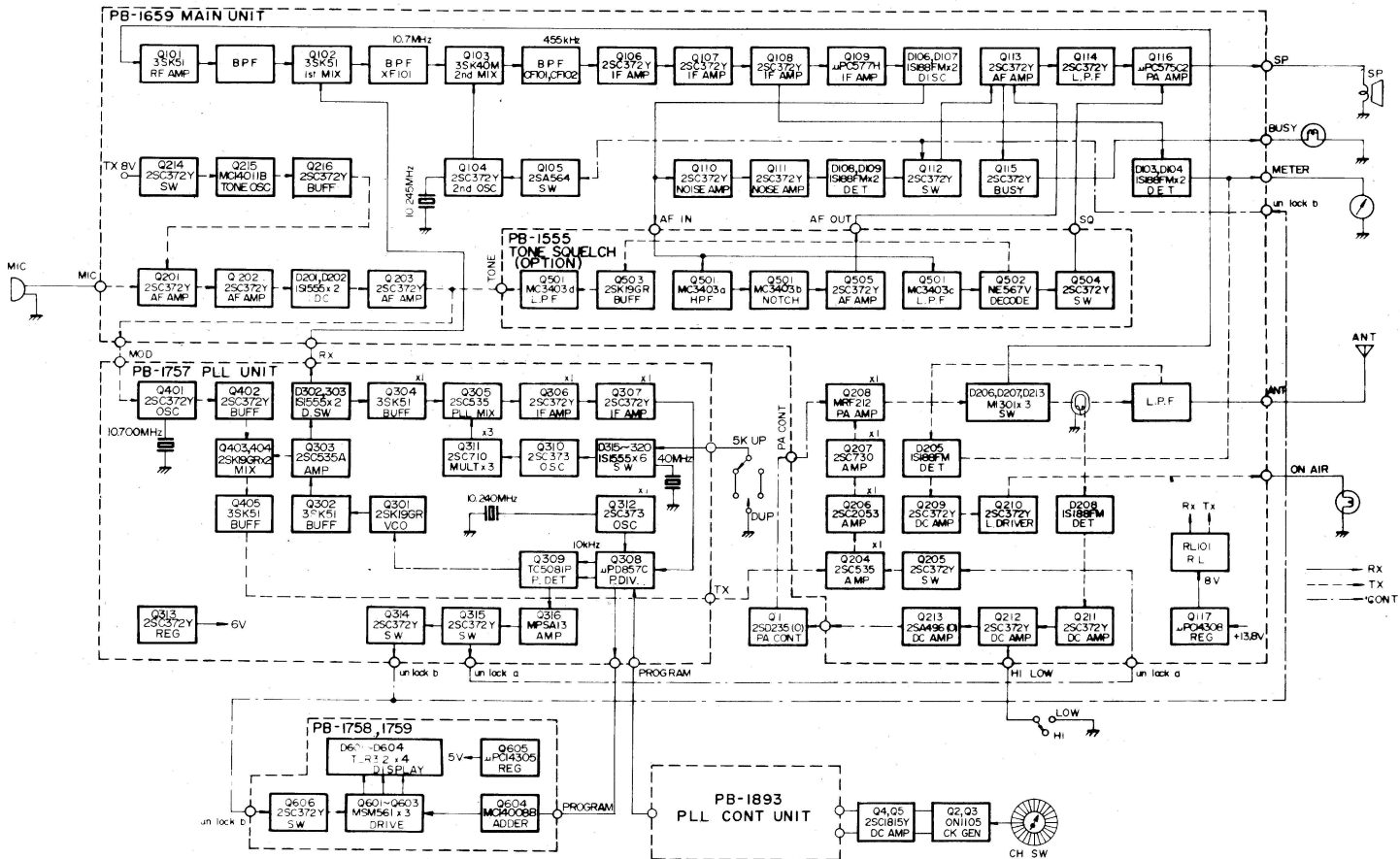

FT-227RB MEMORIZER BLOCK DIAGRAM

## THEORY OF OPERATION

The block diagram, as well as the following circuit description, will provide you with a better understanding of this transceiver. Refer to the schematic diagram for circuit details.

The FT-227RB transceiver consists of a transmitter and a double conversion superheterodyne receiver. A digital phase lock loop synthesizer provides operation on any of the 800 channels within the frequency range of 144–148 MHz. Solid state circuitry is employed throughout, and computer theory is utilized for frequency selection. The transceiver is designed for use from a 13.8 volt DC power source.

### TRANSMITTER

The transmitter produces a Frequency Modulated (FM) signal. The audio signal from the microphone is set to the proper level by VR<sub>201</sub>, and is amplified by Q<sub>201</sub>, Q<sub>202</sub>, and Q<sub>203</sub> (2SC372Y). The audio output from Q<sub>202</sub> is coupled to the Instantaneous Deviation Control (IDC) circuit, where both positive and negative peaks are clipped by diodes D<sub>201</sub> and D<sub>202</sub> (1S1555). The output from the last amplifier (Q<sub>203</sub>) is fed through a low-pass filter, which attenuates frequencies above the speech range caused by clipping at the IDC; the deviation level is set by VR<sub>202</sub>. This control is normally set for a deviation of  $\pm 5$  kHz. The speech signal is then applied to the phase modulator varactor diode, D<sub>401</sub> (1SV50), which varies the frequency of the 10.7 MHz crystal controlled oscillator, Q<sub>401</sub> (2SC372Y). The frequency modulated 10.7 MHz signal is then amplified by a buffer amplifier, Q<sub>402</sub> (2SC372Y), and fed to the balanced mixer, Q<sub>403</sub> and Q<sub>404</sub> (2SK19GR), where the signal is converted up to 144–148 MHz by mixing with the 133.3–137.3 MHz signal delivered from the Voltage Controlled Oscillator (VCO). The output from the balanced mixer is fed through the tuned circuits, consisting of T<sub>404</sub>–T<sub>407</sub>, to a MOSFET amplifier, Q<sub>405</sub> (3SK51-03). T<sub>404</sub>–T<sub>407</sub> are tuned to the transmitting frequency by varactor diodes D<sub>403</sub>–D<sub>406</sub>, whose capacitances are varied in accordance with the DC output voltage from the PLL unit. The 144–148 MHz signal is then amplified by amplifier stages Q<sub>204</sub> (2SC535A), Q<sub>206</sub> (2SC2053), Q<sub>207</sub> (2SC730), and Q<sub>208</sub> (MRF212), which deliver 10 watts of RF energy,

through a diode switch and low pass filter, to the antenna.

Diodes D<sub>205</sub> and D<sub>211</sub> (1S188FM) rectify a small portion of the RF output and apply the resultant DC voltage to the meter, which indicates relative transmitter power output.

The DC output from D<sub>205</sub> is also delivered to the lamp driver, Q<sub>209</sub>–Q<sub>210</sub> (2SC372Y), turning the ON AIR lamp on during transmission.

If the transmitter is keyed without an antenna being connected, or if a high SWR exists in the antenna system, the reflected power is detected through T<sub>202</sub> and a diode, D<sub>208</sub> (1S188FM), which produces a DC voltage. Q<sub>211</sub> (2SC372Y) conducts with the application of the DC voltage through VR<sub>205</sub>, causing a decrease in the collector current of Q<sub>212</sub> (2SC372Y).

Thus, the collector voltage of Q<sub>213</sub> (2SA496) drops, causing Q<sub>11</sub> (2SD235) to decrease current and supply voltage to the PA amplifier, preventing damage to the transistor. The threshold level is set by VR<sub>205</sub>.

The antenna changeover circuit consists of switching diodes D<sub>206</sub> and D<sub>207</sub> (MI1301).

The tone burst circuit consists of a timing generator and a gated multivibrator. With the BURST switch in the ON position, a DC voltage is applied to the tone burst current. When the transmitter is keyed, Q<sub>214</sub> (2SC372Y) conducts, triggering the one-shot multivibrator, Q<sub>215</sub> (MC14011B). The other half of Q<sub>215</sub> generates a tone signal, which is amplified by buffer Q<sub>216</sub> (2SC372Y), and applied to the microphone circuit of the transmitter.

The tone frequency is adjusted by VR<sub>207</sub>, while the output level of the burst signal is adjusted by VR<sub>209</sub>. The burst duration is set by VR<sub>208</sub>.

## RECEIVER

The input signal from the antenna is fed through the low-pass filter, consisting of  $L_1$ ,  $L_{213}$ ,  $L_{214}$ ,  $C_1$ , and  $C_{243}$ – $C_{245}$ , the diode changeover switch  $D_{206}$ – $D_{207}$ , and  $L_{212}$ , to the RF amplifier,  $Q_{101}$  (3SK51). The amplified signal is then applied, through a four-stage high-Q coaxial resonator system, to the first mixer,  $Q_{102}$  (3SK51). The use of MOSFET components, in conjunction with the high-Q resonator, minimizes the effects of intermodulation, as well as other spurious responses; a low noise figure is also secured for the receiver system.

The 144–148 MHz signal is heterodyned with the local oscillator signal from the VCO circuit, producing a 10.7 MHz first IF signal. The first IF signal is fed through crystal filter  $XF_{101}$ , which has a passband of  $\pm 7.5$  kHz, to the second mixer,  $Q_{103}$  (3SK40M), resulting in a second IF of 455 kHz. The second local oscillator signal of 10.245 kHz is generated by  $Q_{104}$  (2SC372Y).  $Q_{105}$  (2SA564) works as a switch which disconnects the supply voltage to  $Q_{104}$  when the PLL circuit is unlocked.

The IF signal is amplified by  $Q_{106}$ ,  $Q_{107}$ , and  $Q_{108}$  (2SC372Y), and  $Q_{109}$  ( $\mu$ PC577H). Cascade-connected ceramic filters  $CF_{101}$  and  $CF_{102}$  provide narrow band selectivity for the receiver, and the limiting action of  $Q_{109}$  removes any amplitude variation in the IF signal, which is subsequently fed to the discriminator,  $CD_{101}$ ,  $D_{106}$ , and  $D_{107}$  (1S188FM).

The discriminator produces an audio output in response to a corresponding frequency shift in the IF signal. The output audio signal is amplified by  $Q_{113}$  and  $Q_{114}$  (2SC372Y), and applied across volume control  $VR_1$  to the input of audio amplifier  $Q_{116}$  ( $\mu$ PC575C2). The output from  $Q_{116}$  in series through the ACC socket to the internal speaker. The low-pass filter between  $Q_{113}$  and  $Q_{114}$  attenuates the audio spectrum above 3 kHz, to increase readability of the incoming signal.

A portion of the 455 kHz IF signal is rectified by  $D_{103}$  and  $D_{104}$  (1S188FM) for S-meter indication.  $VR_{101}$  is used to set the meter sensitivity.

When no carrier is present in the 455 kHz IF, the high frequency noise at the discriminator output is amplified by  $Q_{110}$  and  $Q_{111}$  (2SC372Y), and then detected by  $D_{108}$  and  $D_{109}$  (1S188FM), producing a DC voltage. This voltage is then applied to turn  $Q_{112}$  (2SC372Y) ON. With the conduction of  $Q_{112}$ , the base of  $Q_{113}$  is grounded, squelching the audio amplifier. When a carrier is present in the 455 kHz IF, the noise is removed from the discriminator output, and the audio amplifier recovers normal operation.

The opening of the squelch circuit causes  $Q_{113}$  to conduct, causing lamp driver  $Q_{115}$  (2SC372Y) to draw current, lighting up the BUSY lamp. The squelch controls,  $VR_2$  and  $VR_{102}$ , set the squelch threshold level.

## HETERODYNE OSCILLATOR

The heterodyne signal is generated by a Phase Locked Loop (PLL) circuit, comprised of a VCO, reference crystal oscillator, programmable divider, and phase comparator.

The VCO transistor,  $Q_{301}$  (2SK19GR), generates a signal of 133.3–137.3 MHz. The oscillator frequency is controlled by varactor diode  $D_{301}$  (1S2209), which varies the capacitance of a tuned circuit consisting of  $L_{301}$ ,  $TC_{301}$ , and  $C_{304}$ , in accordance with a DC voltage supplied from phase comparator  $Q_{309}$  (TC5081P).

The output signal from  $Q_{301}$  is amplified by buffer amplifier  $Q_{302}$  (3SK51-03). The signal is further amplified by  $Q_{303}$  (2SC535A), and fed through diode switches  $D_{302}$  and  $D_{303}$  (1S1555), to the transmitter and receiver mixers.

A portion of the output from  $Q_{303}$  is fed through buffer amplifier  $Q_{304}$  (3SK51-03) to PLL mixer  $Q_{305}$  (2SC535A), producing a 1–5 MHz PLL IF signal, through mixing with the PLL heterodyne signal. The latter signal is generated by an overtone crystal-controlled oscillator,  $Q_{310}$  (2SC372Y). The amplified signal is then fed to a programmable divider,  $Q_{308}$  ( $\mu$ PC857C).

Crystal oscillator  $Q_{312}$  (2SC373) generates a 10.24 MHz signal, and its output is fed to scaler/divider  $Q_{308}$  ( $\mu$ PC857C), where the 10.24 MHz signal is divided into a 10 kHz reference signal.

The digital phase comparator, Q<sub>309</sub> (TC5081P), compares the phase of the PLL IF signal with that of the reference signal, and any difference is converted into an error-correcting voltage. This error-correcting voltage is fed to varactor diode D<sub>301</sub>, which changes the output signal phase to lock with that of the reference signal.

When the VCO is locked, the constant voltage at pin 4 of Q<sub>309</sub> is applied to Q<sub>316</sub> (MPSA13), causing it to conduct; in turn, Q<sub>315</sub> (2SC372Y) cuts off. The H voltage at the collector of Q<sub>315</sub> causes Q<sub>205</sub> (2SC372Y) to conduct, supplying DC voltage to exciter stages Q<sub>204</sub> and Q<sub>206</sub>. When the VCO is unlocked, the DC voltage at the emitter of Q<sub>205</sub> drops, preventing normal operation of Q<sub>204</sub> and Q<sub>206</sub>.

The output voltage from Q<sub>315</sub> is reversed in polarity by Q<sub>314</sub> (2SC372Y), and applied to Q<sub>606</sub> (2SC372Y), keeping the collector of Q<sub>606</sub> at the H level, in order to drive Q<sub>601</sub>–Q<sub>603</sub> (MSM561) for the display of the channel frequency. The voltage is also applied to Q<sub>105</sub> (2SA564), which supplies DC voltage to the second heterodyne oscillator, Q<sub>104</sub> (2SC372Y).

When the VCO is unlocked, the collector of DC voltage drops, causing the LEDs to turn off. Simultaneously, the second heterodyne oscillator ceases to oscillate. The receiver is thus muted until VCO lock occurs.

## PLL CONTROL UNIT

Please refer to the PLL Control Unit logic diagram for questions regarding the operation of this circuitry. A complete treatment of every logic state is beyond the scope of this manual.

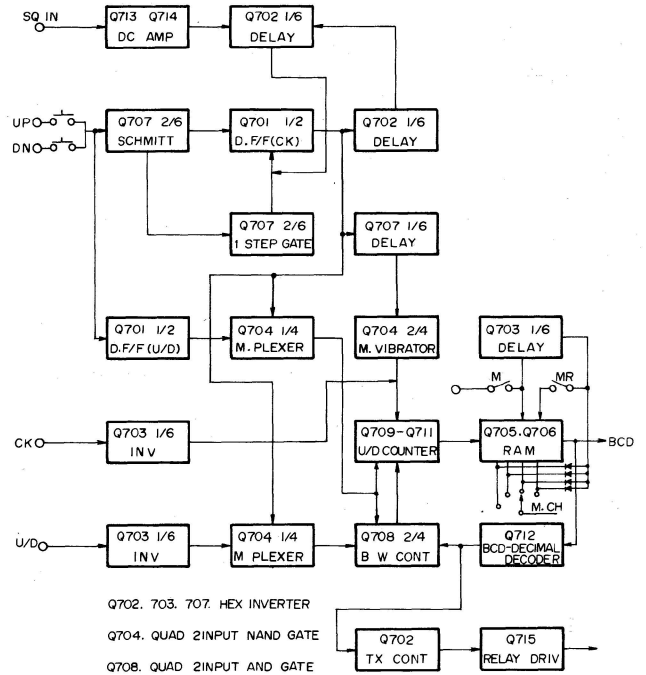

Crystal	Frequency	PLL Het. Freq.	Remarks
X301	44.10000 MHz	132.300 MHz	Simplex
X302	43.90000 "	131.700 "	TX -600 kHz shift
X303	44.30000 "	132.900 "	TX +600 kHz shift
X304	44.10166 "	132.305 "	Simplex 5 kHz up
X305	43.90166 "	131.705 "	TX -600 kHz 5 kHz up
X306	44.30166 "	132.905 "	TX +600 kHz 5 kHz up

## POWER SUPPLY

A 13.8 volt DC supply is used for the audio power amplifier, Q<sub>116</sub>, as well as the relay and lamps. The supply voltage for the final amplifier is fed through voltage regulator Q<sub>1</sub> (2SD235D), which is controlled by the automatic final protection unit.

Voltage regulator Q<sub>605</sub> ( $\mu$ PC14305) regulates the supply voltage at 5 volts, to supply Q<sub>308</sub> and the display unit. Q<sub>313</sub> (2SC372Y) and D<sub>301</sub>(RD6.8EB) regulates the supply voltage at 6 volts for the VCO and phase comparator. The 5 volt supply for the PLL control unit is regulated by zener diode D<sub>3</sub> (WZ050), and is connected directly (not via the power switch) for memory backup purposes.

A regulated 8 volt circuit using Q<sub>117</sub> ( $\mu$ PC14308) is used for all other circuits.

When the transceiver is used in the memory mode, D<sub>4</sub> and D<sub>5</sub> (WZ050) supply 5 volts to the receiver and transmitter, respectively.

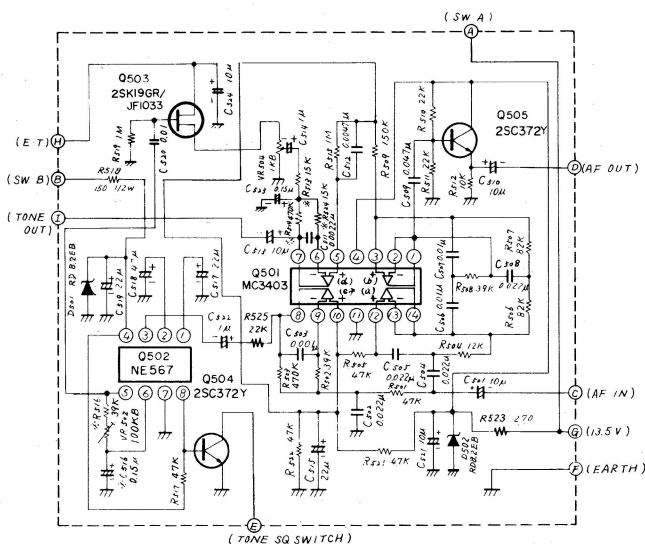

TONE SQUELCH (PB-1555A) OPTION

	C 516 *	R 516 *	R 513 *	R 514 *	R 524 *
70Hz   160Hz	0.15 $\mu$ F	39K $\Omega$	15K $\Omega$	470K $\Omega$	15K $\Omega$
160Hz   250Hz	0.1 $\mu$ F	33K $\Omega$	8.2K $\Omega$	270K $\Omega$	8.2K $\Omega$

Table 2

## TONE SQUELCH UNIT (OPTION)

The tone squelch circuit disables the audio circuit of the receiver until a preset, subaudible tone is received. On transmit, a subaudible tone is superimposed on the output audio signal. The frequency of this tone can be set to any frequency between 70 Hz and 250 Hz.

The tone signal is generated by Q<sub>502</sub> (NE567), and its frequency is set by R<sub>516</sub>, VR<sub>502</sub>, and C<sub>516</sub>. The level of the tone signal is set by VR<sub>504</sub>, and the signal is subsequently fed through buffer amplifier Q<sub>503</sub> (2SK19GR) to a low pass filter on unit "d" of operational amplifier Q<sub>501</sub> (MC3403). The tone signal is then superimposed on the speech signal at Q<sub>202</sub>. The constants for setting the subaudible tone frequency are shown in Table 2.

The audio output signal from the receiver discriminator is fed to unit "a" of Q<sub>501</sub>. Unit "a" of Q<sub>501</sub> acts as a high-pass filter, while unit "b" acts as a T-notch filter. These filters remove the subaudible tone from the audio signal, which is then fed through audio amplifier Q<sub>505</sub> (2SC372Y) to amplifier Q<sub>113</sub>.

The subaudible tone then passes through a low-pass filter at unit "c" of Q<sub>501</sub>, and is fed to Q<sub>502</sub>. When the tone frequency is the same as that preset for transmission, the voltage at pin 8 of Q<sub>502</sub> becomes low, causing Q<sub>504</sub> (2SC372Y) to turn off. In turn, proper bias voltage is applied to Q<sub>119</sub>, allowing normal operation.

When the proper tone signal is not present, Q<sub>504</sub> conducts, removing the bias from Q<sub>119</sub>, thus disabling the audio circuit.

As the conventional carrier-controlled squelch is still in operation, irrespective of the condition of the tone squelch, the BUSY lamp will light up when any carrier is received. This feature alerts the operator that the channel is occupied, though no signal may be heard.

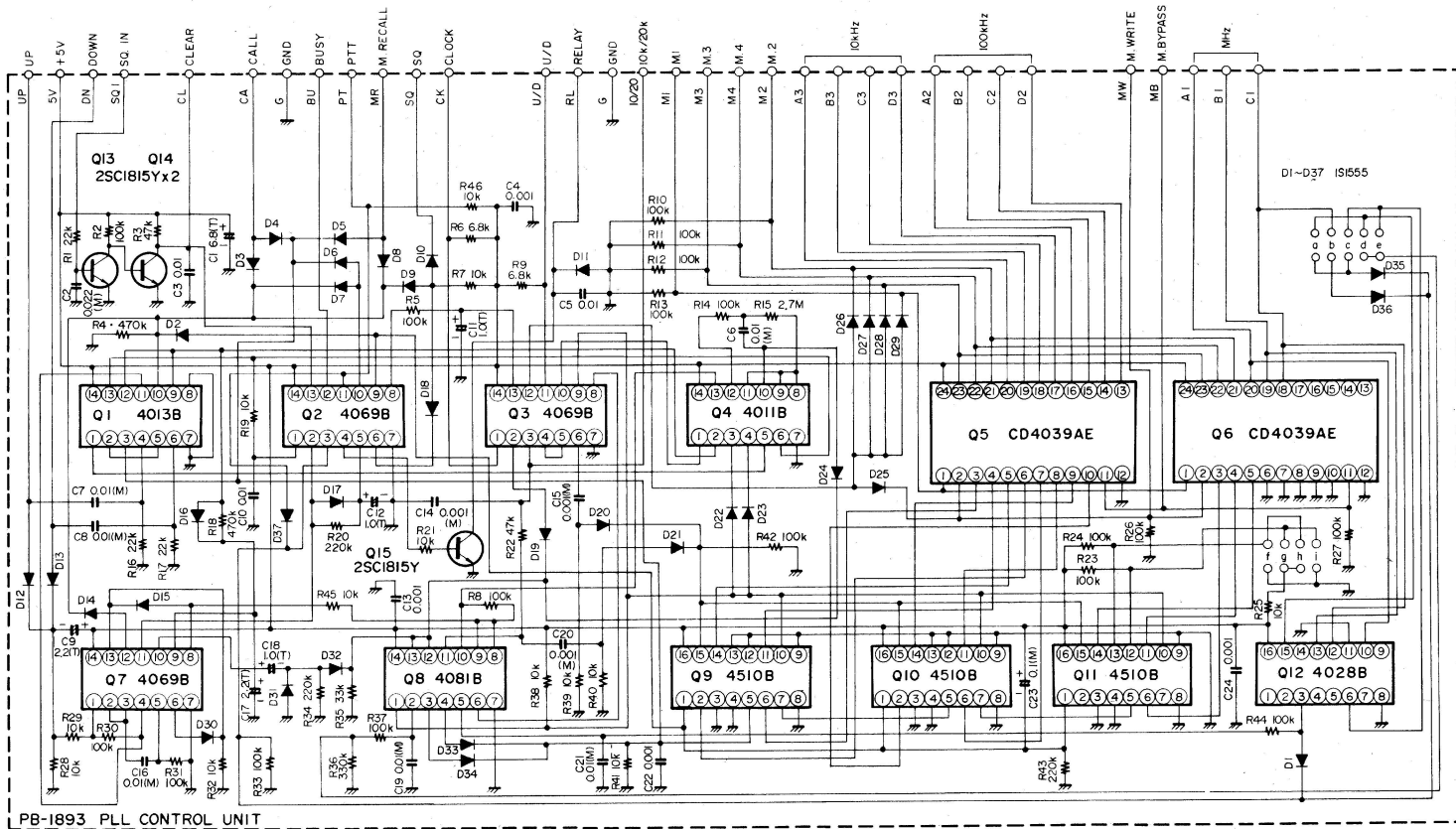

PB-1893 PLL CONTROL UNIT

PLL CONTROL UNIT PB-1893

# CRYSTAL DATA FT-227RB

FUNCTION	HOLDER	RANGE (MHz)	MODE	LOAD C	SERIES R	DRIVE LEVEL
REFERENCE (X <sub>407</sub> )	HC-18/U	10.240	Fundamental	30 pF	25 Ω	2 mW
2nd Local (X <sub>101</sub> )	HC-18/U	10.245	Fundamental	30 pF	25 Ω	2 mW
Carrier (X <sub>401</sub> )	HC-18/U	*10.700	Fundamental	30 pF	20 Ω	2 mW
PLL Local	HC-18/U	(X <sub>301</sub> )	3rd overtone	20 pF	40 Ω	2 mW
		(X <sub>302</sub> )				
		(X <sub>303</sub> )				
		(X <sub>304</sub> )				
		(X <sub>305</sub> )				
		(X <sub>306</sub> )				

\*ACTUAL FREQUENCY: 10.740 MHz

Load Capacitor: 30 pF, 40 kHz UP (Decided by circuit)

## PLL CIRCUIT FREQUENCY RELATIONS

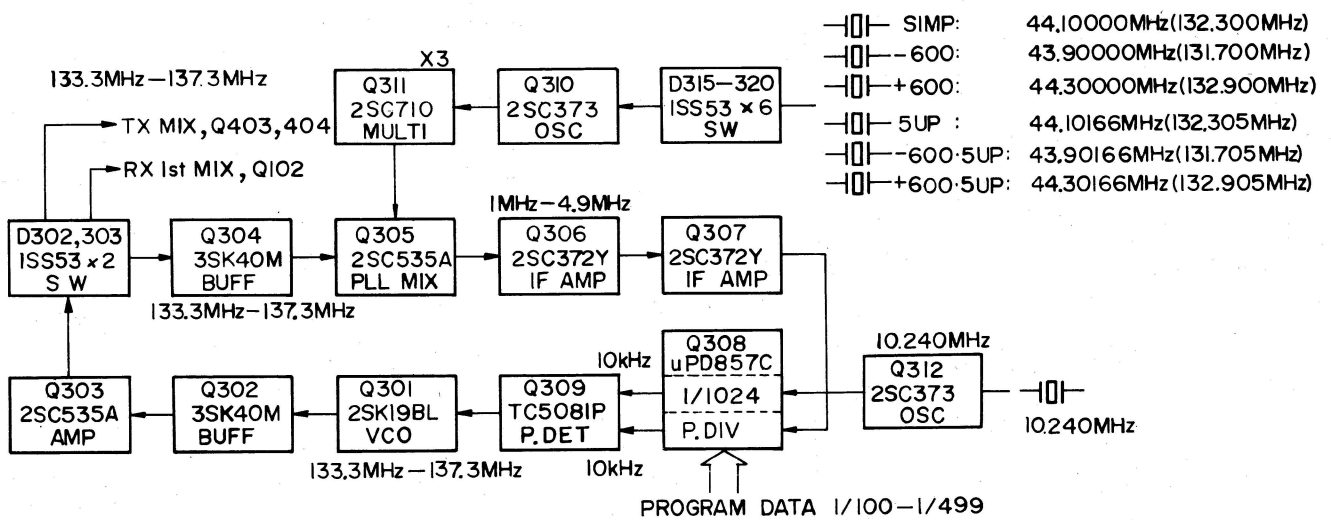

# Q308 ( $\mu$ PD857C) PROGRAMMABLE DIVIDER CODE

Q 308 PROGRAMMABLE INPUT PIN →			1	2	3	4	5	6	7	8	9	10	11
P/J305 →			4	5	6	7	8	9	10	11	12	13	14
P/J304 →			11	10	9	8	7	6	5	4	3	2	1
FREQUENCY ↓	DIAL DISPLAY ↓	PROGRAMMABLE DIVIDER RATIO ↓											
			P <sub>1</sub>	P <sub>2</sub>	P <sub>3</sub>	P <sub>4</sub>	P <sub>5</sub>	P <sub>6</sub>	P <sub>7</sub>	P <sub>8</sub>	P <sub>9</sub>	P <sub>10</sub>	P <sub>11</sub>
144.00	4.000	1/100	0	0	0	0	0	0	0	0	1	0	0
4.01	4.010	1/101	1	0	0	0	0	0	0	0	1	0	0
4.02	4.020	1/102	0	1	0	0	0	0	0	0	1	0	0
4.03	4.030	1/103	1	1	0	0	0	0	0	0	1	0	0
4.04	4.040	1/104	0	0	1	0	0	0	0	0	1	0	0
4.05	4.050	1/105	1	0	1	0	0	0	0	0	1	0	0
4.06	4.060	1/106	0	1	1	0	0	0	0	0	1	0	0
4.07	4.070	1/107	1	1	1	0	0	0	0	0	1	0	0
4.08	4.080	1/108	0	0	0	1	0	0	0	0	1	0	0
4.09	4.090	1/109	1	0	0	1	0	0	0	0	1	0	0
144.10	4.100	1/110	0	0	0	0	1	0	0	0	1	0	0
4.11	4.110	1/111	1	0	0	0	1	0	0	0	1	0	0
4.12	4.120	1/112	0	1	0	0	1	0	0	0	1	0	0
4.13	4.130	1/113	1	1	0	0	1	0	0	0	1	0	0
4.14	4.140	1/114	0	0	1	0	1	0	0	0	1	0	0
4.15	4.150	1/115	1	0	1	0	1	0	0	0	1	0	0
4.16	4.160	1/116	0	1	1	0	1	0	0	0	1	0	0
4.17	4.170	1/117	1	1	1	0	1	0	0	0	1	0	0
4.18	4.180	1/118	0	0	0	1	1	0	0	0	1	0	0
4.19	4.190	1/119	1	0	0	1	1	0	0	0	1	0	0
144.20	4.200	1/120	0	0	0	0	0	1	0	0	1	0	0
4.30	4.300	1/130	0	0	0	0	1	1	0	0	1	0	0
4.40	4.400	1/140	0	0	0	0	0	0	1	0	1	0	0
4.50	4.500	1/150	0	0	0	0	1	0	1	0	1	0	0
4.60	4.600	1/160	0	0	0	0	0	1	1	0	1	0	0
4.70	4.700	1/170	0	0	0	0	1	1	1	0	1	0	0
4.80	4.800	1/180	0	0	0	0	0	0	0	1	1	0	0
4.90	4.900	1/190	0	0	0	0	1	0	0	1	1	0	0
145.00	5.000	1/200	0	0	0	0	0	0	0	0	0	1	0
145.01	5.010	1/201	1	0	0	0	0	0	0	0	0	1	0
145.02	5.020	1/202	0	1	0	0	0	0	0	0	0	1	0
145.03	5.030	1/203	1	1	0	0	0	0	0	0	0	1	0
145.04	5.040	1/204	0	0	1	0	0	0	0	0	0	1	0
145.05	5.050	1/205	1	0	1	0	0	0	0	0	0	1	0
145.06	5.060	1/206	0	1	1	0	0	0	0	0	0	1	0
145.07	5.070	1/207	1	1	1	0	0	0	0	0	0	1	0
145.08	5.080	1/208	0	0	0	1	0	0	0	0	0	1	0
145.09	5.090	1/209	1	0	0	1	0	0	0	0	0	1	0
145.10	5.100	1/210	0	0	0	0	1	0	0	0	0	1	0
145.20	5.200	1/220	0	0	0	0	0	1	0	0	0	1	0
145.30	5.300	1/230	0	0	0	0	1	1	0	0	0	1	0
145.40	5.400	1/240	0	0	0	0	0	0	1	0	0	1	0
145.50	5.500	1/250	0	0	0	0	1	0	1	0	0	1	0
145.60	5.600	1/260	0	0	0	0	0	1	1	0	0	1	0
145.70	5.700	1/270	0	0	0	0	1	1	1	0	0	1	0
145.80	5.800	1/280	0	0	0	0	0	0	0	1	0	1	0
145.90	5.900	1/290	0	0	0	0	1	0	0	1	0	1	0
146.00	6.000	1/300	0	0	0	0	0	0	0	0	1	1	0
147.00	7.000	1/400	0	0	0	0	0	0	0	0	0	0	1
147.99	7.990	1/499	1	0	0	1	1	0	0	1	0	0	1

※ 1 HIGH LEVEL (5V)

※ 0 LOW LEVEL (0V)

# MAINTENANCE & ALIGNMENT

## GENERAL

The model FT-227RB transceiver has been carefully aligned and tested at the factory prior to shipment. The reliability of the solid-state devices used in the FT-227RB should provide years of trouble free service if the transceiver is not abused and normal, routine maintenance is carried out.

THE FOLLOWING PRECAUTIONS SHOULD BE OBSERVED TO PREVENT DAMAGE TO THE TRANSCEIVER.

- (1) Do not exceed 14 Volts DC, at the POWER receptacle.  
When operating mobile, check the battery voltage under the load (transmitter "keyed" in FM mode) with the engine running fast enough so the ammeter shows a "charge". In addition, do not operate the FT-227RB if the supply voltage is below 12 Volts DC.
- (2) Avoid direct exposure to sunshine or water.

## ROUTINE MAINTENANCE

Routine maintenance should be limited to keeping the transceiver clean, and periodic performance checks of the transmitter RF power output and the receiver sensitivity.

### Cleaning:

When the transceiver has been used in dusty or sandy areas, the interior should be periodically cleaned. A vacuum cleaner should be used, while any caked or accumulated dirt may be removed with a soft brush. Check the interior to make sure that it is thoroughly dry before replacing the case and/or operating equipment. Wipe the exterior with a damp cloth whenever required.

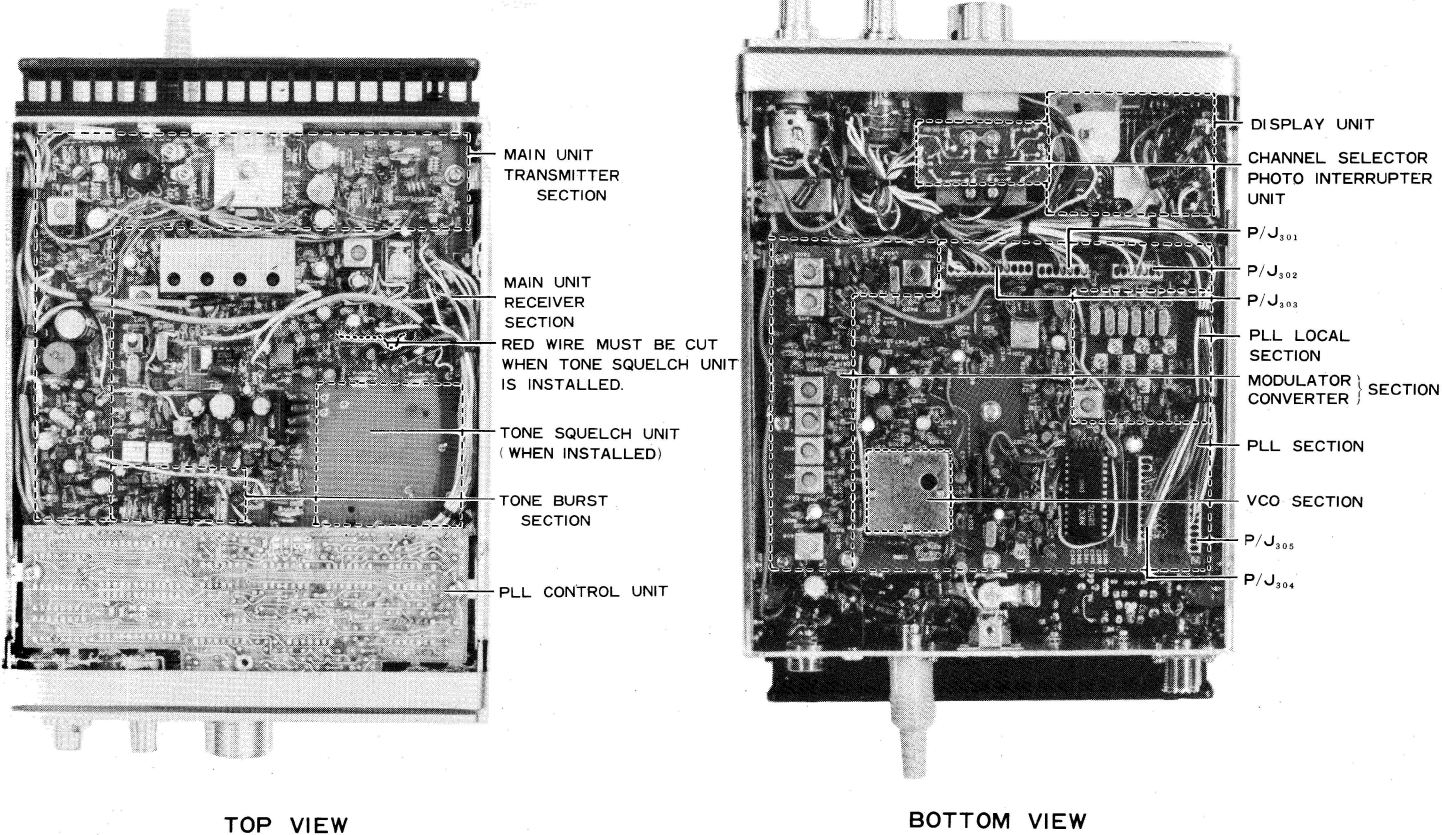

## PERFORMANCE CHECKS

Make all performance checks at 13.5 Volts DC (under load).

Check the transmitter output as follows:

- (a) Connect a suitable 50 ohm dummy load/RF wattmeter to the ANT receptacle.
- (b) Set the channel selector to any channel and key the transmitter while observing the power output. The power should be approximately 10 watts, and the S-meter should read between 6 and 8 relative power output.

Check the receiver sensitivity as follows:

- (a) Connect an AC VTVM to the SP receptacle, and set the SQUELCH control fully counter-clockwise.

- (b) Connect the RF output of a precision VHF signal generator to the ANT receptacle and with no signal input note the VTVM reading. Adjust the VOLUME control and VTVM range, as required, to obtain an approximate full scale reading. (DO NOT change the VOLUME control setting after this adjustment is made).
- (c) Set the signal generator to the receiving frequency of the transceiver and adjust the output amplitude of the signal generator until the VTVM reads 20dB (1/10th voltage) lower than the reading in step (b). The signal generator output voltage at this point is the 20 dB quieting sensitivity, and should be approximately 0.3  $\mu$ V.

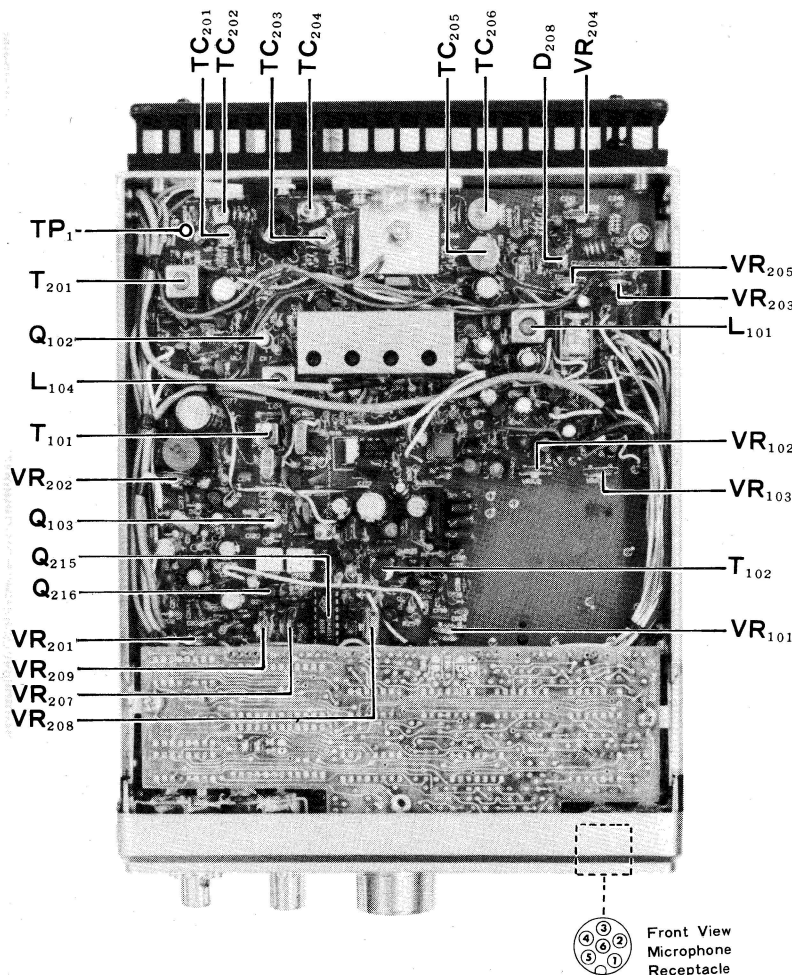

counter  
clockwise clockwise

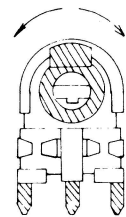

Front View

counter  
clockwise clockwise

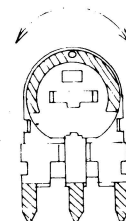

Rear View

Figure 7

ALIGNMENT POINT

## ALIGNMENT

SOME OF THE FOLLOWING ALIGNMENT PROCEDURES REQUIRE SPECIAL TEST EQUIPMENT AND TECHNIQUES AND SHOULD ONLY BE DONE BY AN EXPERT TECHNICIAN.

### TRANSMITTER

#### (1) RF Power Amplifier

- a) Set the channel to 147.0 MHz. Connect a YP-150 50 ohm dummy load/watt meter to the antenna connector. Connect a VTVM between TP1 and ground (1 V DC range).
- b) Key the transmitter and peak  $T_{201}$  for maximum VTVM reading.

#### (2) PO Meter

Set  $VR_{203}$  to the point where the S meter shows 8 with full output.

#### (3) AFP (Automatic Final Protection)

- a) Connect the YP-150 to the antenna connector. Set  $VR_{205}$  to the extreme CCW position. Connect the VTVM to cathode (+) of  $D_{208}$  and ground (-) and adjust  $VR_{204}$  for minimum VTVM reading.
- b) Disconnect the dummy load from the antenna jack. Set  $VR_{205}$  to the fully clockwise position. Key the transmitter, and slowly rotate  $VR_{205}$  in a CCW direction until the PO meter reading becomes 4.

#### (4) Deviation

- a) Connect YP-150 to the antenna connector, the output of an audio oscillator between pin 6 (hot) and 5 (ground) of microphone receptacle and a deviation meter as illustrated in Fig. 8. Set the audio output level to 25 mV at 1 kHz.
- b) Connect a frequency counter between TP3 of the PLL unit and ground.
- c) Key the transmitter by grounding pin 4 of microphone receptacle. Adjust  $T_{401}$  for a 10.7 MHz counter reading.

- d) Set the output level of the audio signal generator to 25 mV at 1 kHz and adjust  $VR_{202}$  for  $\pm 5$  kHz deviation.

- e) Set the audio level to 2.5 mV. Adjust  $VR_{201}$  for a deviation of  $\pm 2.5$  kHz.

#### (5) Tone Burst

- a) Connect a YP-150 dummy load to the antenna connector and disconnect the microphone to prevent accidental voice modulation.
- b) Temporarily connect pin 5 of  $Q_{215}$  to pin 14.
- c) Connect a YC-500 frequency counter to the emitter of  $Q_{216}$ , and set TONE BURST switch to the ON position.
- d) Key the transmitter and adjust  $VR_{207}$  to the desired burst frequency.
- e) Connect VTVM to MIC IN terminal and adjust  $VR_{209}$  for 2.5 mV VTVM reading.
- f) Remove the wire temporarily connected in step (b). Key the transmitter and adjust  $VR_{208}$  for desired burst duration.

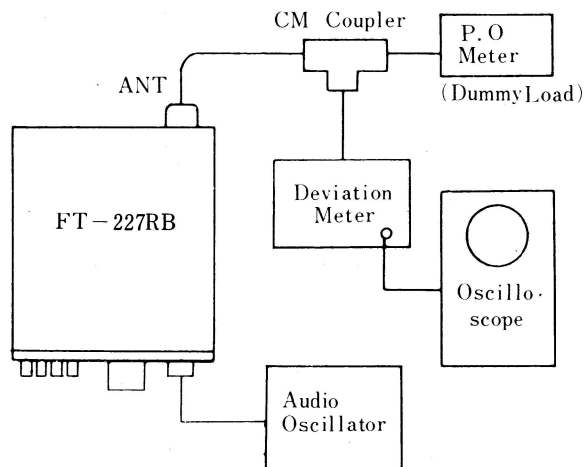

Figure 8

## RECEIVER

### (1) RF Amplifier

- a) Connect the calibrated signal generator to the antenna connector and set the channel selector to 147.0 MHz.
- b) Tune the signal generator to the receive frequency and peak  $L_{101}$  through  $L_{104}$  and  $TC_{101}$  through  $TC_{104}$  for maximum S meter reading.

### (2) First IF Amplifier

- a) Connect a sweep generator to the second gate of  $Q_{102}$ . Connect an oscilloscope through a detector to the drain of  $Q_{103}$ .
- b) Set the frequency of the sweep generator to 10.7 MHz and apply its output. Adjust  $T_{101}$  until the scope pattern illustrated in Fig. 9. is available.

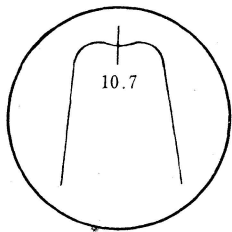

Figure 9

- c) Disconnect the sweep generator and scope. Measure the RF injection voltage to the second gate of  $Q_{103}$ . A nominal value is 0.8-1.0 volt rms.
- ### (3) S Meter Sensitivity
- a) Apply the signal generator output to the antenna connector. Peak  $T_{102}$  for maximum S meter reading.
  - b) Set the output level of the signal generator to 20 dB and adjust  $VR_{101}$  for full scale indication on the S meter.
- ### (4) Squelch Threshold
- a) Receive a 0 dB signal from the signal generator.
  - b) Set the SQL control on the front panel fully clockwise. Now adjust  $VR_{102}$  to the point where the squelch just opens.
  - c) Set the generator level to -10 dB. Press the TONE SQ button, and adjust  $VR_{103}$  to the

point where the BUSY lamp just turns on.

- d) Turn off the signal generator, and turn off the tone squelch. Check to see that the front panel SQL control causes the squelch to open when the knob is turned approximately to the 9 to 10 o'clock position.

### PLL Circuit

- a) Set the channel frequency to 146.00 MHz.
- b) Connect the YC500S frequency counter to  $TP_1$  of the PLL unit and adjust  $TC_{309}$  for 5.1200 MHz, and make sure the RF voltage of the emitter of  $Q_{312}$  is approximately 1.6 volts rms.
- c) Connect RF probe of the VTVM to the base of  $Q_{311}$  and peak  $TC_{308}$  for maximum VTVM reading. Slowly rotate  $TC_{308}$  in the direction of increasing capacitance until the VTVM reading becomes 5% lower than peak indication (approx. 60 mV rms).
- d) Connect RF probe of the VTVM to the base of  $Q_{305}$ . Key the transmitter and peak  $T_{302}$  for maximum VTVM reading (approx. 170 mV rms).
- e) Connect the YC-500S frequency counter between the cathode of  $D_{302}$  in PLL unit and ground. Set the FUNCTION switch to SIMP. Adjust  $TC_{302}$  for 135.3 MHz counter reading.
- f) Set the FUNCTION switch to -600. Key the transmitter and adjust  $TC_{303}$  for 134.7 MHz counter reading. Then Adjust  $TC_{304}$  for 135.900 MHz at +600.
- g) Set the FUNCTION switch to SIMP. Press 5 UP switch down. Adjust  $TC_{305}$  for 135.305 MHz in receive mode. Key the transmitter at -600 and adjust  $TC_{306}$  for 134.705 MHz; at +600 kHz adjust  $TC_{307}$  for 135.905 MHz.
- h) Connect VTVM (DC 10 V range) between the cathode of  $D_{324}$  and ground. Adjust  $TC_{301}$  for 3.4 volt VTVM reading.
- i) Connect RF probe of VTVM between TX out terminal and ground in PLL unit. Peak  $T_{403}$  -  $T_{408}$  for maximum VTVM reading in transmit.

## PLL CONTROL UNIT

As this unit requires no alignment, trouble in this unit should be referred to a qualified technician for fault detection and parts replacement. This unit is highly sophisticated, and any attempt to service it without the proper knowledge is discouraged.

## TONE SQUELCH UNIT (OPTION)

The optional tone squelch unit has been preset to 77 Hz center frequency at the factory. However, the frequency can be set to any frequency between 70 Hz and 250 Hz by referring to Table 2, located on page 15, and by adjustment of VR<sub>504</sub>.

The tone output level adjustment is made at VR<sub>502</sub>.

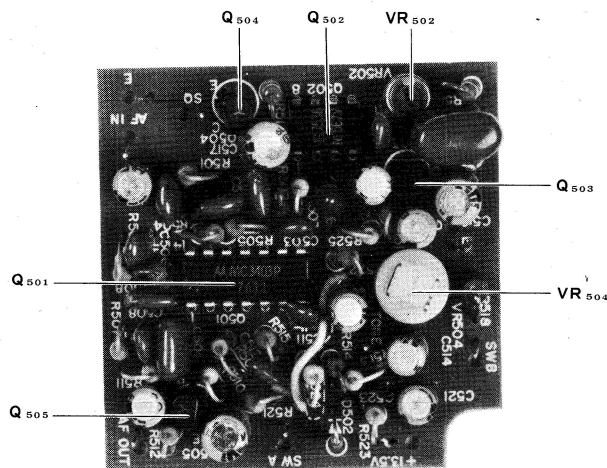
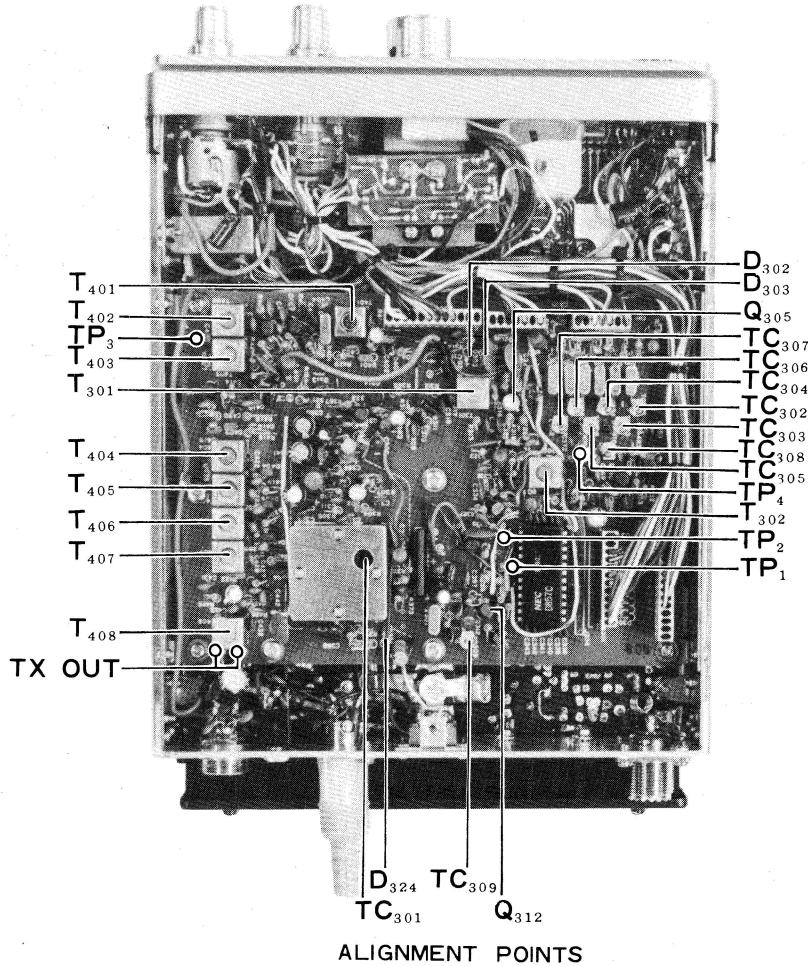

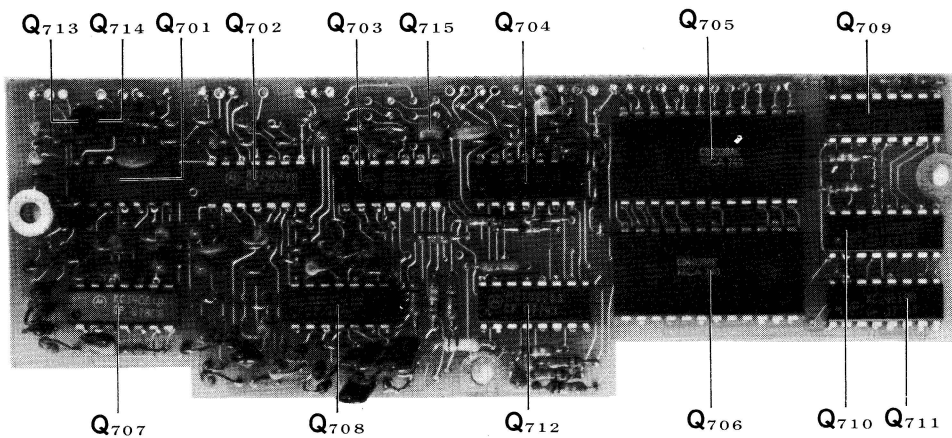
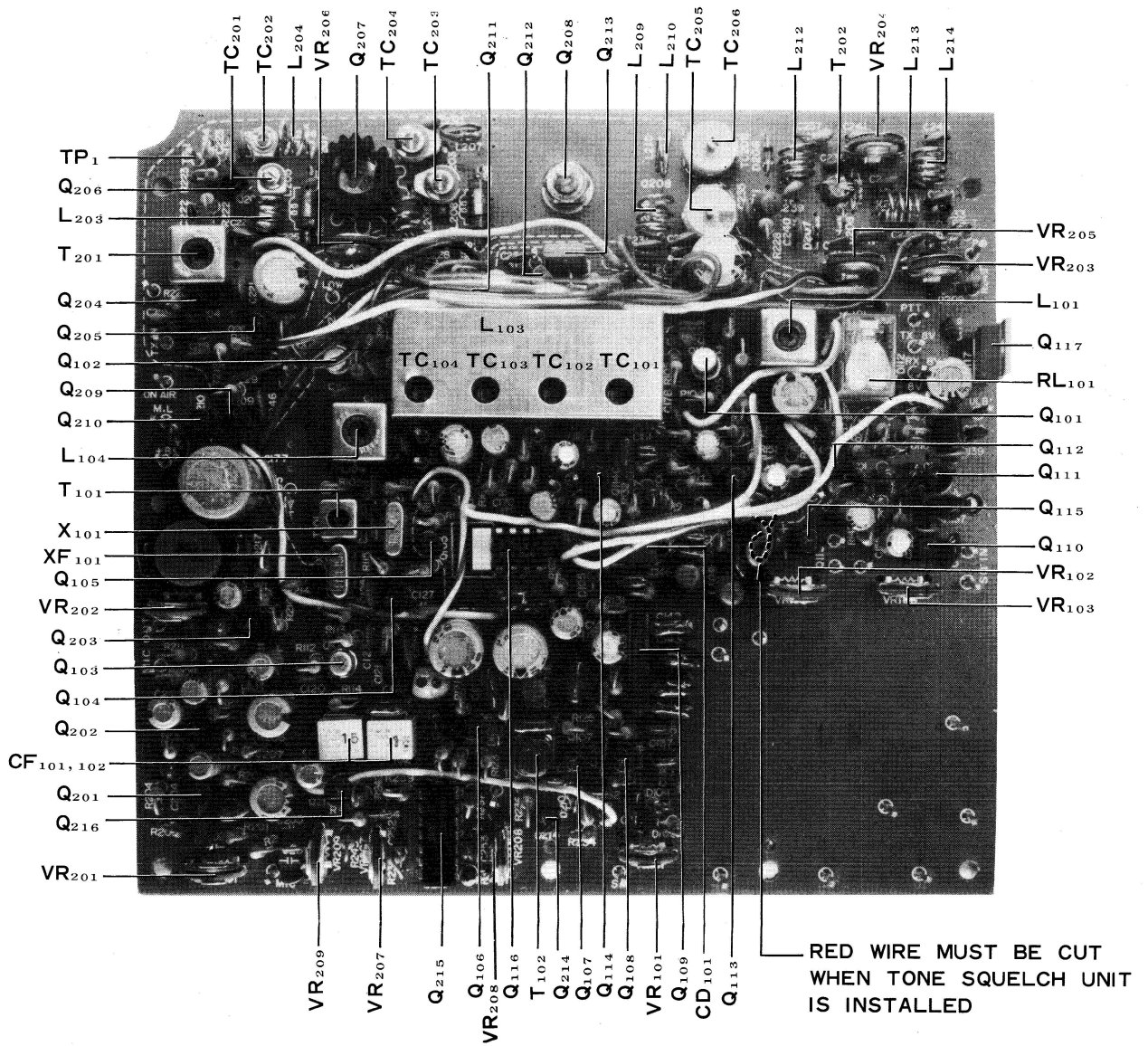

PLL CONTROL UNIT

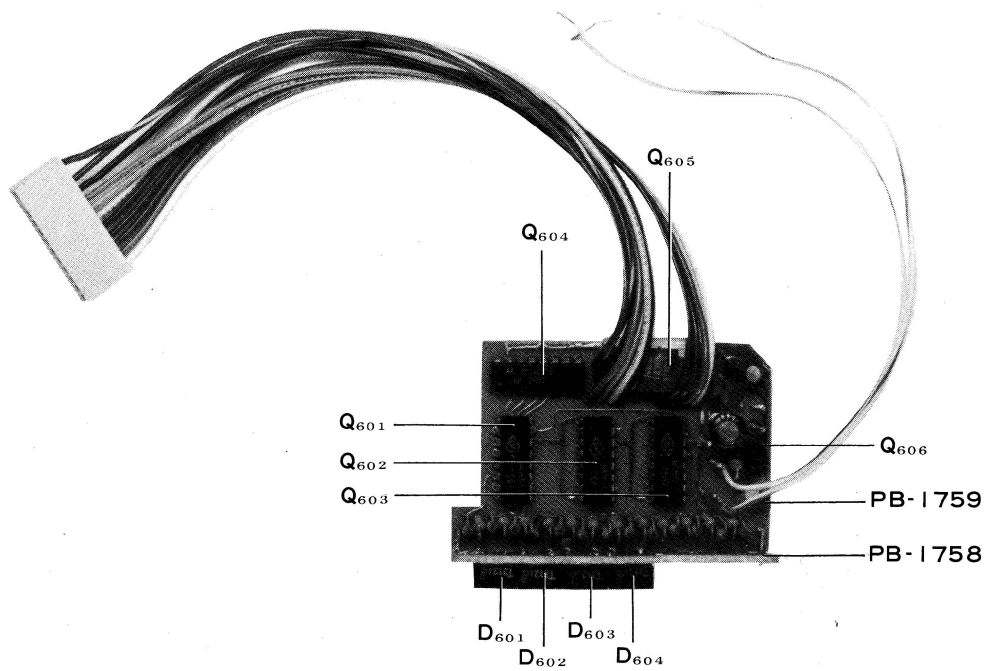
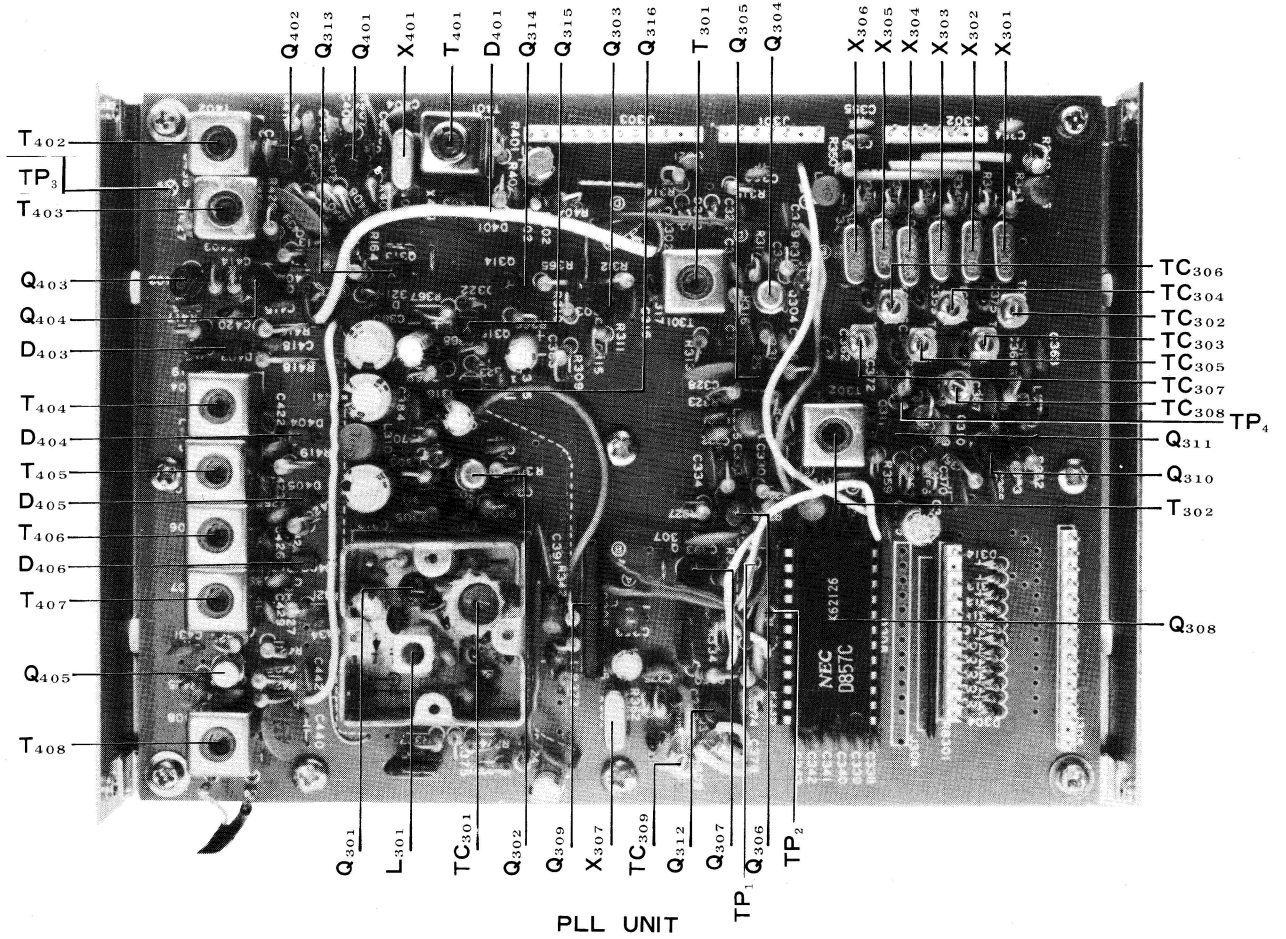

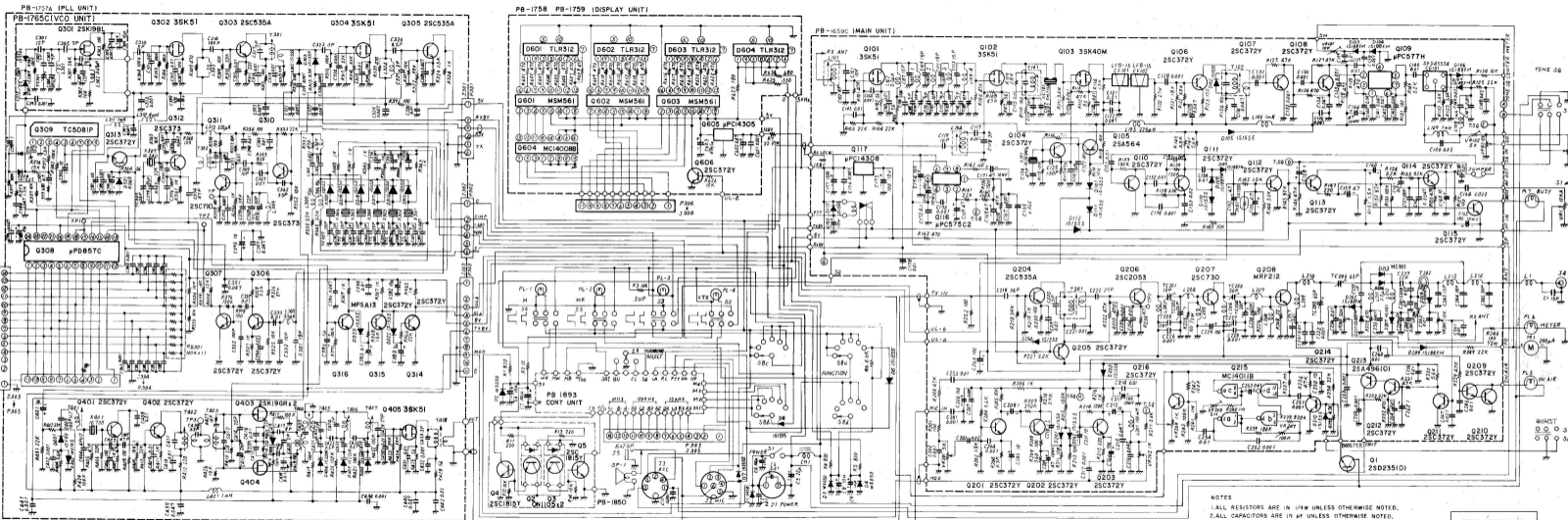

NOTES  
 1. ALL RESISTORS ARE IN  $\Omega$  UNLESS OTHERWISE NOTED.  
 2. ALL CAPACITORS ARE IN  $\mu$ F UNLESS OTHERWISE NOTED.  
 3. ALL ELECTROLYTIC CAPACITORS ARE 16V UNLESS OTHERWISE NOTED.  
 4. X VALUE IS NOMINAL.

**FT-227RB**  
**CIRCUIT DIAGRAM**

#### **IMPORTANT NOTE**

Your Yaesu equipment is backed by a warranty that guarantees your set to be free of defects. Take a few minutes to read the warranty card carefully. Make certain that you fill out the card completely, and mail it at once, in order to qualify for warranty service.

Warranty service is to be performed by the dealer from whom the equipment was purchased. Do not return the equipment to Yaesu for servicing without first getting a service authorization from the Yaesu Service Center. Estimates of the approximate cost to repair are available upon request.

