

# INSTRUCTION MANUAL FT-230R



**YAESU ELECTRONICS CORP.  
P.O. BOX 49  
PARAMOUNT, CA 90723  
U.S.A.**

**YAESU MUSEN CO., LTD.  
C.P.O. BOX 1500  
TOKYO, JAPAN**



## TABLE OF CONTENTS

	(Page)
INTRODUCTION .....	1
SPECIFICATIONS .....	2
SEMICONDUCTORS .....	3
ACCESSORIES .....	3
FRONT PANEL CONTROLS AND SWITCHES .....	4
REAR APRON SWITCHES AND JACKS .....	8
INSTALLATION .....	10
OPERATION .....	15
BLOCK DIAGRAM .....	22
CIRCUIT DESCRIPTION .....	23
MAINTENANCE AND ALIGNMENT .....	27
PARTS LIST .....	38

### Model Chart

Model	A	B	C	D	E
Frequency Range	144.000 – 147.995MHz	144.000 – 145.9875MHz	144.000 – 147.9875MHz	144.000 – 147.995MHz	144.000 – 147.995MHz
Preset Frequency	147.000MHz	145.000MHz	145.000MHz	145.000MHz	147.000MHz
Frequency Step	5kHz/10kHz	12.5kHz/25kHz	12.5kHz/25kHz	5kHz/10kHz	5kHz/10kHz
Repeater Shift	±600kHz	±600kHz	±600kHz	±600kHz	±600kHz
Tone Call/ Burst	1800Hz	1750Hz	1750Hz	1750Hz	1800Hz
Tone Squelch	FTS-32/ FTS-32AE (optional)	–	–	–	–
Hi/Low Output	–	25W/3W, 10W/1W	25W/3W, 10W/1W	25W/3W, 10W/1W	25W/3W, 10W/1W

# FT-230R

## 2 METER FM TRANSCEIVER



### INTRODUCTION

The FT-230R is a microprocessor controlled, compact synthesized FM transceiver that provides a full 25 watts of RF power output on the two meter amateur band. With ten memories and two VFOs, selectable 5 kHz or 10 kHz tuning rates (12.5 and 25 kHz for Europe) and priority channel functions all controllable manually or automatically via the scanner, the FT-230R leaves nothing out.

Additionally, the FT-230R utilizes a large-digit Liquid Crystal Display with some new developments in optics permitting an unusually wide viewing angle and spectacular illumination for the ultimate in frequency and function indication under all lighting environments. Tone Calling and Tone Squelch (or Hi/Lo power in European Models) are easily selected from the front panel. A lithium battery is included for memory backup with an estimated lifetime of 5 years or more.

The extremely small size and light weight of the FT-230R, together with its high output power, make it a truly remarkable unit for the best in FM mobile operation today.

We recommend that you read this manual in its entirety so as to understand clearly the many features of the exciting new FT-230R. With proper care in operation, this equipment will provide many years of reliable performance.

# SPECIFICATIONS

<b>Frequency Coverage</b>	: 144.00 – 147.995 MHz; 144.00 – 145.995 MHz (as per your local regulations)
<b>Synthesizer Steps</b>	: 5/10 or 12.5/25 kHz (depending on local requirements)
<b>Power Output</b>	: 25 watts (10 watts where required)
<b>Mode of Operation</b>	: F3(FM)
<b>Modulation Type</b>	: Variable Reactance
<b>Deviation</b>	: $\pm 5$ kHz maximum
<b>Maximum Bandwidth</b>	: 16 kHz
<b>Tone Burst Frequency</b>	: 1800 Hz (Model A, E), 1750 Hz (Model B, C, D)
<b>Spurious Emissions</b>	: -60 dB or better
<b>Antenna Connector</b>	: SO-239
<b>Output Impedance</b>	: 50 ohms
<b>Microphone Impedance</b>	: 500 – 600 ohms
<b>Receiver Type</b>	: Double Conversion Superheterodyne
<b>First IF</b>	: 10.7 MHz
<b>Second IF</b>	: 455 kHz
<b>Sensitivity</b>	: 0.25 $\mu$ V for 12 dB SINAD 1 $\mu$ V for 30 dB S/N
<b>Selectivity</b>	: $\pm 7.5$ kHz (-6 dB), $\pm 15$ kHz (-60 dB)
<b>Audio Output</b>	: 1.0 watt @ 8 ohms
<b>Audio Output Impedance</b>	: 8 ohms
<b>Power Requirements</b>	: 13.8VDC (negative ground)
<b>Current Consumption</b>	: 5.0 A on transmit (RF 25 W output) 0.3 A on receive
<b>Case Size</b>	: 150 (W) x 50 (H) x 174 (D) mm
<b>Weight</b>	: Approx. 1.3 kg

Specifications subject to change without notice.

## Options

YM-49	Speaker/Microphone
FTS-32	CTCSS Encoder/Decoder
FTS-32E	CTCSS Encoder

# SEMICONDUCTOR COMPLEMENT

ICs:		FETs:		DIODEs:	
HD44820-A18	1	2SK19TMGR	1	1S188FM (Ge)	6
TP0401	1	2SK61-O	1	1S1555 (Si)	6
TC5082P	1	2SK168D	3	1SS53 (Si)	24
MC14002B	1	3SK51-03	4	U05B (Si)	1
MC14011B	1	<b>TRANSISTORS:</b>		1SS97	1
MC14069UB	2		2SA564Q	1	(Schottky barrier)
MC3357P	1	2SC496Y	1	1SV68 (Varactor)	1
M57715	1	2SC535A	2	1SV69 (Varactor)	5
(10 W model)		2SC945AP	6	1T25 (Varactor)	1
M57712	1	2SC1383	1	HZ6C-1L (Zener)	1
(25 W model)		2SC1815Y	11	WZ061 (Zener)	1
$\mu$ PC575-C2	1	2SC2026	1	WZ090 (Zener)	2
$\mu$ PC577H	1	2SC2053	1	MV13 (Varistor)	1
$\mu$ PD2819C	1	2SC2407	1	BG4632K (LED)	1
78L05	1	2SC2785E	1	PR4632K(LED)	1
		2SD636R	1		
				<b>LCD:</b>	
				H1313A	1

## ACCESSORIES

MICROPHONE (WITH HANGER)	YM-47	(M3090033)	1
EXTERNAL SPEAKER PLUG	C-107	(P1090139)	1
DC POWER CORD			1
10W MODEL		(T9002805)	
25W MODEL		(T9006710)	
CIGARETTE LIGHTER PLUG	CP-103	(P0090067)	1
SPARE FUSE			1
10W MODEL 5A		(Q0000004)	
25W MODEL 10A		(Q0000007)	
MOUNT BRACKET ASSY			1
WIRE STAND (WITH HOLDER)			1

# FRONT PANEL CONTROLS AND SWITCHES

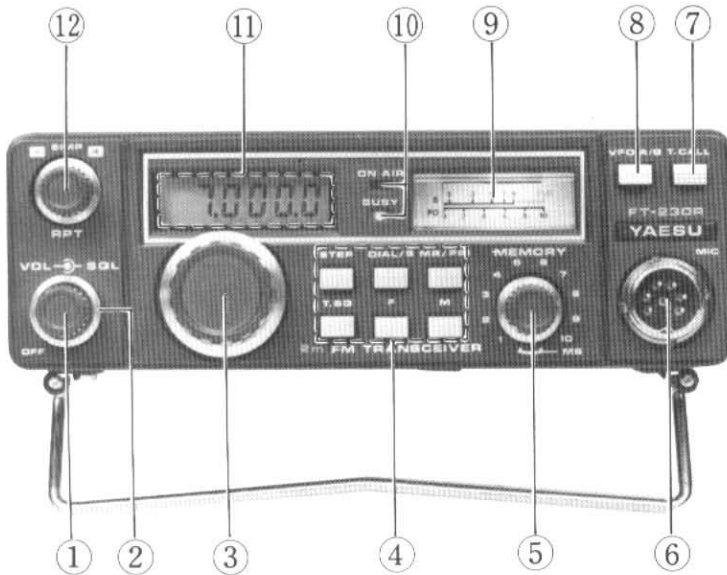

## (1) VOL/OFF

The volume control adjusts the audio output and, when rotated fully counter-clockwise, switches the transceiver off.

## (2) SQL

The squelch control silences the receiver when no stations are being received on the frequency. Advance the squelch control clockwise just to the point where the background noise is silenced. Further rotation will reduce sensitivity to weak signals.

## (3) MAIN DIAL

The main tuning dial is used for selection of operating frequencies using the two VFOs. Tuning steps are 5 or 10 kHz (or 12.5 or 25 kHz in the European version) as selected by the step button (4-1).

#### **(4) KEYBOARD SWITCHES**

##### **1) STEP**

Push this momentary pushbutton switch to change the PLL tuning rate for either the main tuning dial or the scanner.

##### **2) DIAL/S**

When this button is pushed tuning will be accomplished by the main dial on either VFO A or VFO B, unless the F button (4-5) is pushed first (up to 3 seconds before), in which case the memory split mode will be selected; and the transceiver will receive on the selected memory while transmitting on the VFO frequency (until DIAL/S is pressed again).

##### **3) MR/PRI**

This momentary pushbutton selects either the memory channel or priority channel recall. If only this button is pressed, the memory channel selected by the MEMORY rotary selector will be recalled. If the F button (4-5) is pressed first (up to three seconds before) and then the MR/PRI button, the priority channel is recalled.

##### **4) T. SQ (HI/LO on European version)**

The T. SQ two-position pushbutton switch activates the tone squelch option when installed in the USA version. In the European version this HI/LO switch selects either 25 watts (out position) or 3 watts (in position).

##### **5) F**

This (Function) button activates either the priority channel mode or the memory split mode when pressed before pressing the MR/PRI or DIAL/S buttons (by alerting the microprocessor that a function change command will follow.) If either the MR/PRI or DIAL/S button is not pressed within three seconds after pressing F, the F command will be cancelled automatically.

## **6) M**

Press this button to store the displayed frequency into the memory channel selected by the MEMORY selector. When stored, an "M" will appear on the left side of the display.

## **(5) MEMORY Selector**

This 12-position rotary selector switch selects the memory channel to be used. In the (two) MS positions, the FT-230R will scan the 10 memory channels when directed by the scanning controls on the microphone.

## **(6) MIC**

This seven pin jack accepts microphone audio input, scanning control lines, and the PTT (Push-to-Talk) control line. Microphone impedance is 500-600 ohms.

## **(7) T.CALL**

When this button is pressed an 1800 Hz tone is superimposed on the microphone audio line and the PTT switch line is grounded, activating the transmitter. This feature allows manual-length tone access of repeaters requiring a burst tone.

## **(8) VFO A/B**

This button selects one of the two internal VFOs in the FT-230R. Depress this switch to change from one VFO to the other. This switch has an "in" position for one VFO and an "out" position for the other, so that you can see by the switch position which VFO you have selected.

## **(9) S/PO Meter**

This meter gives you a relative indication of incoming signal strength during receive and power output during transmit.

## **(10) ON AIR and BUSY LEDs**

The red ON AIR LED indicator lights up in the transmit mode, while the green BUSY LED lights up during receive when the squelch is opened by an incoming signal.

## (11) DIGITAL DISPLAY

This Liquid Crystal Display indicates the operating frequency and special functions. The last five digits of the operating frequency are shown with resolution to 0.1 kHz. When a MEMORY channel is selected and displayed an "M" will appear at the lower left side of the display. When the priority channel is selected and displayed a large P will appear for about one second in the leftmost MHz frequency display position. When the F button is pressed, summoning the microprocessor for a special function, a large horizontal bar will appear at the left side of the frequency display for about 3 seconds, during which time the DIAL/S or MR/PRI buttons must be pressed (or the "F" button command will be "forgotten"). Additional display features are described in the OPERATION section.

## (12) RPT

This three-position switch selects either simplex or plus or minus 600 kHz shifts for standard repeater operation. For non-standard offsets use the memory-VFO system described in the OPERATION section.

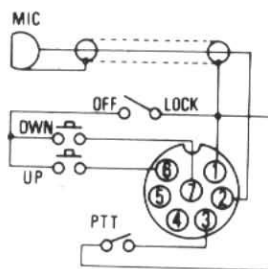
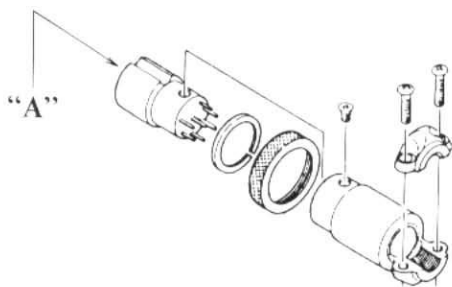

Viewed from "A" Side

YM-47  
MICROPHONE PLUG  
CONNECTIONS

## REAR APRON SWITCHES AND JACKS

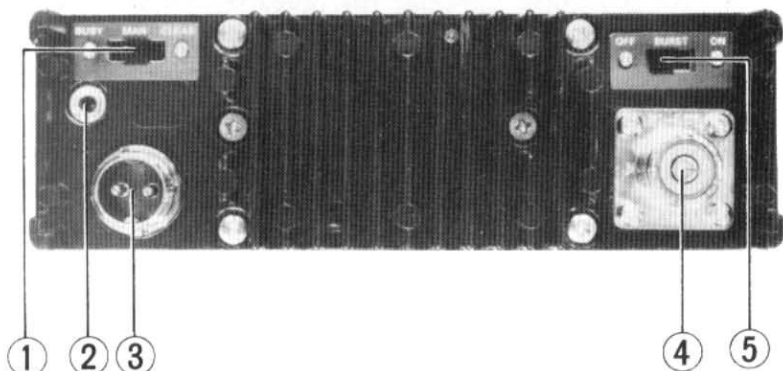

### (1) BUSY-MAN-CLEAR

This three position slide switch selects the scan-stop mode. In the **BUSY** position the scanner will stop at any occupied channel, while in the **CLEAR** position it will stop at any clear channel. In the **MAN** position the automatic scanning is disabled and scanning is then controlled manually by the scan switches on the microphone. When the **BUSY** or **CLEAR** automatic scanning functions are active and the scanner has stopped on a channel, it will resume scanning again automatically within about five seconds unless one of the microphone switches (**PTT**, **UP** or **DWN**) is pressed. Once one of these switches is pressed the automatic scanning will cease until the **UP** or **DWN** switch is pressed again.

#### NOTE

If the scanning is halted with the **PTT** switch, or the automatic scanning is cancelled with the **PTT** switch, the **PTT** switch must be released and pressed again before transmission can occur.

### (2) EXT SP

Use this jack for connecting an external speaker via a mini phone plug. Inserting the plug into this jack will disable the internal speaker. Output impedance is 8 ohms.

### (3) DC 13.8 V

Use the special power connector supplied with the FT-230R for connecting 13.8 VDC ONLY to this jack. Never apply AC power, or DC voltage higher than 15 V to this jack. Be absolutely certain that the proper polarity is applied, and if you change DC plugs, that the new plug is wired correctly. Failure to observe these simple precautions will void any and all warranties on this equipment.

### (4) ANTENNA

This is a type SO-239 coaxial connector for use with a 50 ohm coaxial cable and antenna.

### (5) OFF-BURST-ON

This two-position ON/OFF switch provides a tone burst at the beginning of each transmission when set to the ON position. No tone burst is applied when OFF.

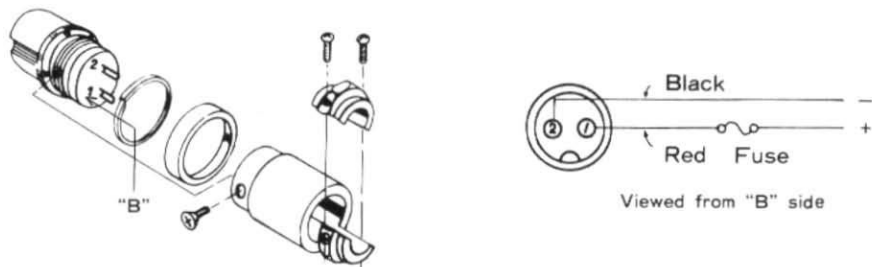

DC POWER CORD PLUG CONNECTIONS

# INSTALLATION

## ANTENNA CONSIDERATIONS

The FT-230R is designed for operation with a 50 ohm resistive load. While some departure from this value is of little significance, it is possible to damage the transmitter circuitry if the transmitter is activated when no antenna is connected.

For base station applications any of the popular vertical antennas, beam or phased arrays will provide excellent performance, so long as they present the proper 50 ohm impedance to the transmitter (using 50 ohm coaxial cable). For mobile applications be sure to use an antenna designed for the 2-meter amateur band, make your coaxial cable as short as possible, and locate the antenna away from the engine and in the middle of a flat metal surface such as the roof or trunk lid (if at all possible) for best performance. Also, where ground connections are made, scrape the surface clean of all paint and corrosion to ensure adequate electrical contact. Lossy ground connections can have seriously detrimental effects on the antenna system impedance and radiation pattern. Use an SWR meter to tune your antenna to the center of the band.

## MOBILE INSTALLATION

Do not install the FT-230R in cars that do not have negative ground. For mobile service the FT-230R should be installed where the digital display, controls and microphone are easily accessible for operation. The transceiver may be installed in any position without affecting its performance, though you must ensure that it will not interfere with normal operation of the vehicle or driver vision. A universal bracket is supplied with your transceiver for mobile installation. Refer to Page 11 for mounting details.

1. Use the mounting bracket as a template for positioning the mounting holes. Use a 3/16" diameter bit for drilling the holes, allowing clearance for the transceiver, its cables and microphone, and access to the controls. Secure the mounting bracket with the screws, washers and nuts supplied, as shown in the drawing.

2. Line up the two holes in the sides of the transceiver with the holes in the mounting bracket that you intend to use, and secure the transceiver into the bracket with the screws and washers supplied. Notice that there are three holes in each side of the transceiver, of which only two are used for mounting; and that there are four holes in each side of the bracket, of which also only two are used. This allows you to select the optimum mounting position for your particular requirements.
  
3. The microphone bracket may be installed wherever convenient for access to the microphone.

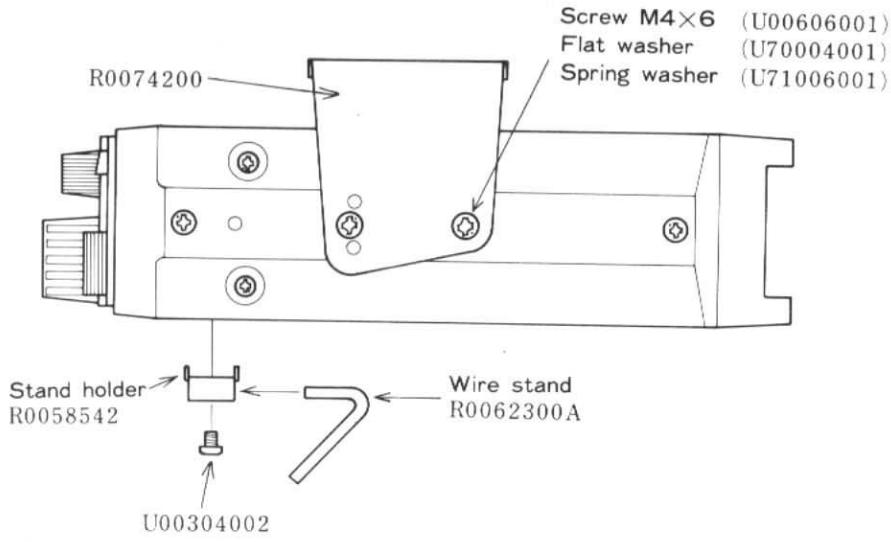
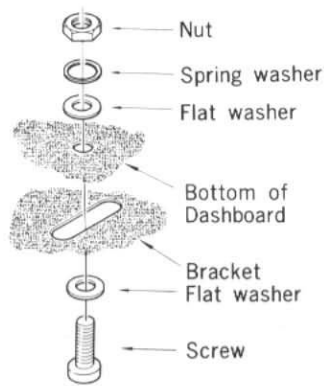

Power connections should be made directly to the automobile battery. Connection to the cigarette lighter or another accessory circuit may cause the fuse to blow in that circuit. Connecting the supplied DC power cable independently of the automobile electrical system will avoid possible ignition noise pickup and excessive supply voltage drop during transmission.

Connect the RED lead of the power cord to the POSITIVE (+) battery terminal, and the BLACK lead to the NEGATIVE (-) terminal. If it is necessary to extend the power cable, use #16 AWG insulated copper wire, and in all cases use the minimum length practicable to keep voltage drop at a minimum.

### WARNING

NEVER APPLY AC POWER TO THE REAR PANEL POWER JACK OF THE TRANSCEIVER. NEVER CONNECT A DC VOLTAGE SOURCE OF MORE THAN 15 VOLTS TO THE REAR PANEL POWER JACK. ALWAYS REPLACE FUSES WITH A FUSE OF THE PROPER RATING (5 amp for 10W version, 10 amp for 25W version). FAILURE TO OBSERVE THESE SIMPLE PRECAUTIONS WILL VOID ALL WARRANTIES ON THIS EQUIPMENT.

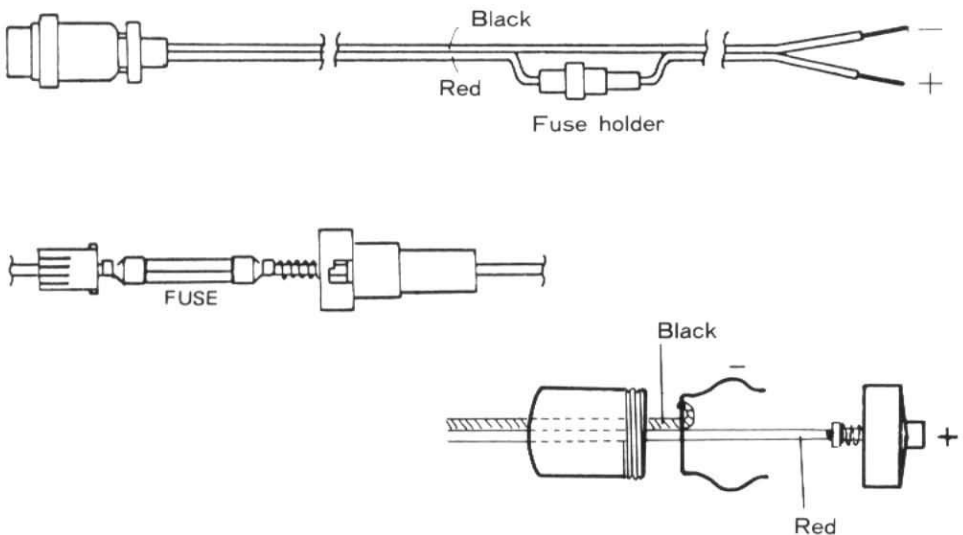

Connect the power cable to the POWER receptacle on the rear panel, connect the coaxial cable from the antenna to the rear panel ANT receptacle, and connect the microphone to the MIC jack. An external speaker may be connected to the rear panel mini phone jack, if desired, disabling the internal speaker.

## BASE STATION INSTALLATION

A base station mounting stand is supplied with your transceiver, to provide easier viewing of the display and controls and clearance for the internal speaker. A power supply capable of supplying at least 6 amps continuous at 13.8 VDC is required for operation from the AC line. The FP-12 AC power supply option is available from your Yaesu dealer for this purpose.



FP-12 for 25W model



FP-80A for 10W model

## MEMORY BACKUP INFORMATION

The FT-230R memory channels are protected by a memory backup lithium cell in the transceiver. When the transceiver leaves our factory the memory backup switch is in the OFF position in order to clear the information in the memory. To activate the memory backup, switch the memory backup switch under the soft rubber plug on the bottom panel of the FT-230R to the ON position. Once this switch is turned on, it is not necessary to turn it off because of the extremely low current consumption of the memory, approximately  $0.1 \mu\text{A}$ . The estimated life of the cell is more than five years, regardless of whether the FT-230R is connected to a power source, or switched ON or OFF. If, after this period, the memory backup becomes intermittent, ask your Yaesu dealer for a replacement cell. Keep the rubber plug in the hole to keep out contamination. If you keep the backup switch in the OFF position, the memories will be cleared whenever the FT-230R is switched off. We recommend that you keep the memory backup ON, as this will not affect battery life noticeably.

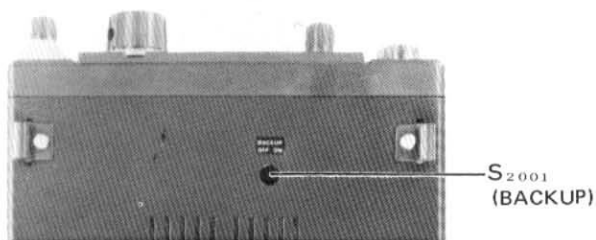

**BACKUP**  
**OFF ON**

OFF      ON



BOTTOM VIEW

# OPERATION

The tuning procedure for this transceiver is not complicated. However, because microcomputer circuitry is used extensively throughout the transceiver, this section should be read carefully so that you clearly understand all of the features that are available.

## INITIAL CHECK

Before operating the transceiver be certain that the power cable is wired correctly with respect to polarity, and that it and the antenna are properly connected to the FT-230R as described in the INSTALLATION section. Also check the backup switch inside the bottom cover. If it is off, we recommend that you switch it on (See MEMORY BACKUP INFORMATION, page 14).

## FREQUENCY READOUT

The Liquid Crystal Display shows the last five digits of the operating frequency to 0.1 kHz. Thus, for example, 145.000.0 MHz will appear on the display as 5.000.0.

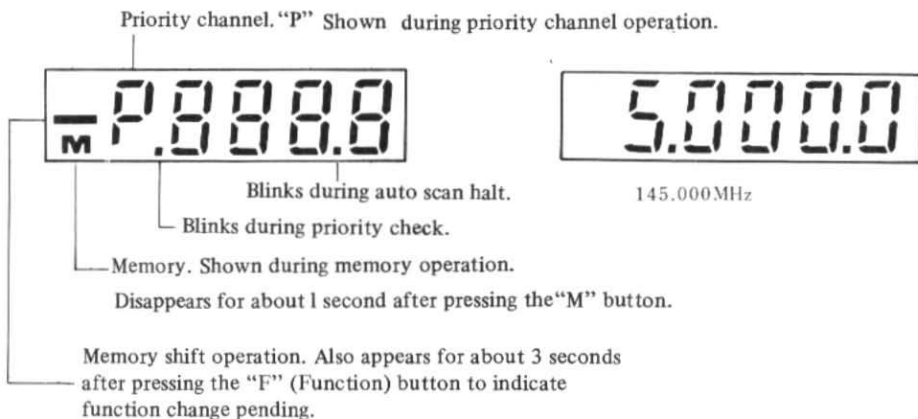

When operating on a memory channel, the letter "M" will appear on the left side of the display. The memory channel number will not be shown here, since it is already shown by the MEMORY Selector switch position. The actual memorized frequency will be displayed, however.

Preset the controls and switches as follows:

VOL	OFF (fully counterclockwise)
SQL	fully counterclockwise
MEMORY	Channel position 1
T.SQ or HI/LO	OFF or HI (out)
BURST (on rear panel)	OFF
BUSY-MAN-CLEAR (on rear panel)	MAN

Rotate the VOL control out of the click-stop and adjust the volume for a comfortable listening level. The LCD should indicate the operating frequency. When the channel is clear, adjust the SQL control so that the background noise just disappears. This threshold point is the point of maximum sensitivity, and advancing the control beyond this will inhibit the receiver from responding to weak signals.

The memory backup will store the frequency, VFO mode (dial or memory) and tuning step automatically so that whenever you switch the FT-230R OFF and later ON, these functions will remain the same. The STEP switch is used to select the desired synthesizer steps for tuning, 5 kHz or 10 kHz (or 12.5 kHz or 25 kHz). When you rotate the main tuning dial, initially the synthesizer will provide whatever step rate was used before the unit was last switched off. Press the STEP button once to change the tuning to the alternate step rate, and press it again to return.

Rotate the main tuning dial until the desired frequency is displayed. To transmit close the PTT switch on the microphone and speak with a clear, normal voice. Release the PTT switch to receive.

For repeater operation, switch the RPT switch to + or - according to the frequency scheme of the repeater you wish to use, assuming it has the standard 600 kHz offset. This selection can be made either during main dial or memory operation.

For operation on odd splits, use a combination of the memory system and the main tuning dial as described in the MEMORY SPLIT OPERATION section, page 20.

The front panel CALL switch activates a manual-length 1800 Hz (or 1750 Hz) tone for repeater access. When this button is pressed, the transmitter is activated and the access tone is superimposed on the transmit signal.

## MEMORY OPERATION

Ten memory channels are available for storage and recall of favorite operating frequencies. The procedure for entry and recall of memory channels is extremely simple.

Push the DIAL/S switch for normal tuning, using the main tuning dial. When you have found a frequency you wish to store in memory (for example 145.520 MHz), rotate the MEMORY selector to 1(channel 1) and push the M (memory store) button. If you wish to store 144.490 MHz in channel 2, rotate the main dial to that frequency, rotate the MEMORY switch to channel 2, and push M, and so forth. This procedure may be repeated for all 10 memory channels.



145.520MHz

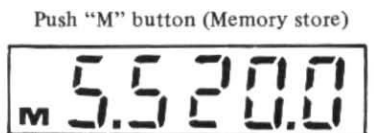

Automatically turns off for about 1 second after pushing "M" button.

To recall these frequencies, push the MR/PRI button (memory recall) and rotate the MEMORY selector to select the desired channel. One push of the MR/PRI button will keep you on memory operation until the DIAL/S

button is pushed again to return you to main dial tuning. Note that there is no formal erasure procedure for memory channels. When you push the M button, the previous frequency stored in that position will be erased.

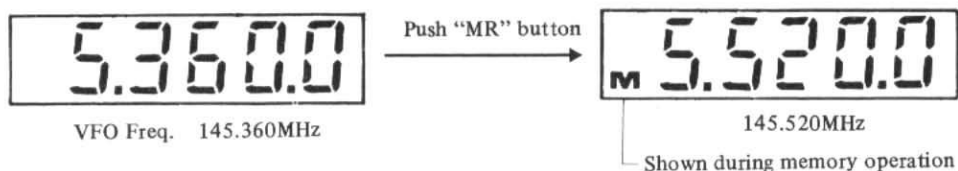

## SCANNER OPERATION

The UP/DWN scanning controls on the microphone may be used to control the operating frequency.

When in the DIAL mode, one push of the UP button will cause the frequency to advance upward by one step of the synthesizer (the step size being programmed by the STEP button). If you hold the UP button down for more than 1/2 second, the scanner will become engaged, and you will begin scanning up the band. Push the UP or DWN button or the PTT switch to halt the scan and, if using the PTT switch for halting, push it again to transmit. Scanning toward a lower frequency is achieved by the same procedure, using the DWN button on the microphone.

To scan only the memory channels, rotate the MEMORY selector to either of the MS (Memory Scan) positions, and press the MR button. Now, when you push and hold (for 1/2 second) the UP or DWN button, the scanner will search the memory channels only. Manual halting of the scan is accomplished by pushing the UP, DWN or PTT buttons as before.

On the rear panel, the **BUSY-MAN-CLEAR** switch allows selection of one of three scan halt modes. In the **MAN** (Manual) position, scanning is halted as discussed above. If the **BUSY** position is selected (see page 8), the scanner will search until a busy channel (one occupied by a station strong enough to break the main squelch) is received. The scan will then pause on that frequency for five seconds. If you choose to stay on that frequency, press one of the scan control buttons or the **PTT** switch. While in the **PAUSE** mode, the decimal point farthest to the right will blink; when you push a button to cancel the resumption of the scan, the blinking will stop.

To scan for a clear channel (one where the squelch does not open), set the **BUSY-MAN-CLEAR** switch to **CLEAR**. The scan will halt, and the decimal point will blink, as in the previous section. Press the **UP**, **DWN**, or **PTT** switch to cancel the pause/resume feature and hold on the frequency you stopped at. If you pushed the **PTT** switch, release it and push again to transmit. Memory scan halting follows the same format as main dial scanning.

## **PRIORITY CHANNEL OPERATION**

Priority channel operation uses a combination of the main dial VFO and the memory. It can be used in conjunction with the automatic scan stop feature of the microprocessor, if desired. The steps for priority channel operation are detailed below.

- (1) Program into memory the desired priority channel. Do not recall the channel at this time.
- (2) Dial up a basic operating frequency on the main VFO (you may, of course, change this frequency later without affecting priority operation). This will be your main operation channel during priority channel operation.
- (3) Set the **BUSY-MAN-CLEAR** switch to **BUSY** or **CLEAR**, as desired.
- (4) Now push the **F** button, followed immediately by a press of the **MR/PRI** button. The letter "P" will appear for one second in the MHz position on the digital display, signifying priority channel operation. The display will then show the VFO frequency, with a flash every five seconds to the priority memory channel being checked for

activity. When the priority memory channel is busy or clear (depending on your instructions at the **BUSY-MAN-CLEAR** Switch), the scanner will halt on the memory channel. The pause/restart feature does not function in this mode; to restart, simply press the **F** and **MR/PRI** buttons again.

- (5) If the scan stop switch is set to the **MAN** position, the CPU will have no instructions for halting the scan on the priority channel. Simply press the **DIAL/S** or **MR/PRI** button to select the desired channel (VFO or priority) under this mode of operation. If you press the **PTT** switch during manual priority channel operation, the checking of the priority channel will be delayed by five seconds.

Whenever priority checking is in operation the MHz decimal point will blink.

## **MEMORY SPLIT OPERATION**

The memory split operation mode is useful for covering unusual repeater splits or other occasions where the receive frequency may be fixed, but the transmit frequency is variable. In this mode, you receive on a memory channel, while transmitting on a VFO.

- (1) Store the desired receive frequency into a memory channel.
- (2) Dial up the desired transmit frequency on the main dial.
- (3) Now press the **F** and **DIAL/S** buttons. You will be receiving on the memory, while transmitting on the VFO.
- (4) If you desire to listen on several memory channels, the memory channel selector may be rotated as desired. If you wish to save this transmit frequency, simply depress the VFO A/B button. You will now activate the alternate VFO whose frequency you can display on receive by pressing the **DIAL/S** button. To return to your odd split, set the memory channel selector to the channel storing the receive frequency, press VFO A/B, **F**, and **DIAL/S**.

During memory split operation the bar will appear to the left of the operating frequency on the display. The small M will also appear below the bar during receive only.

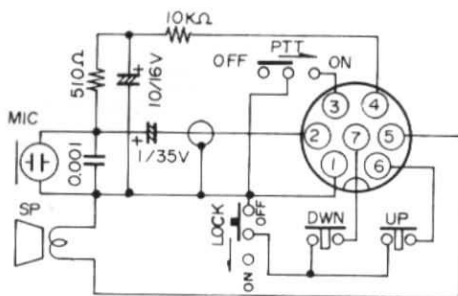
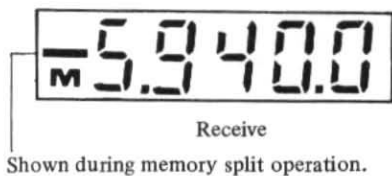

OPTIONAL SPEAKER MICROPHONE YM-49

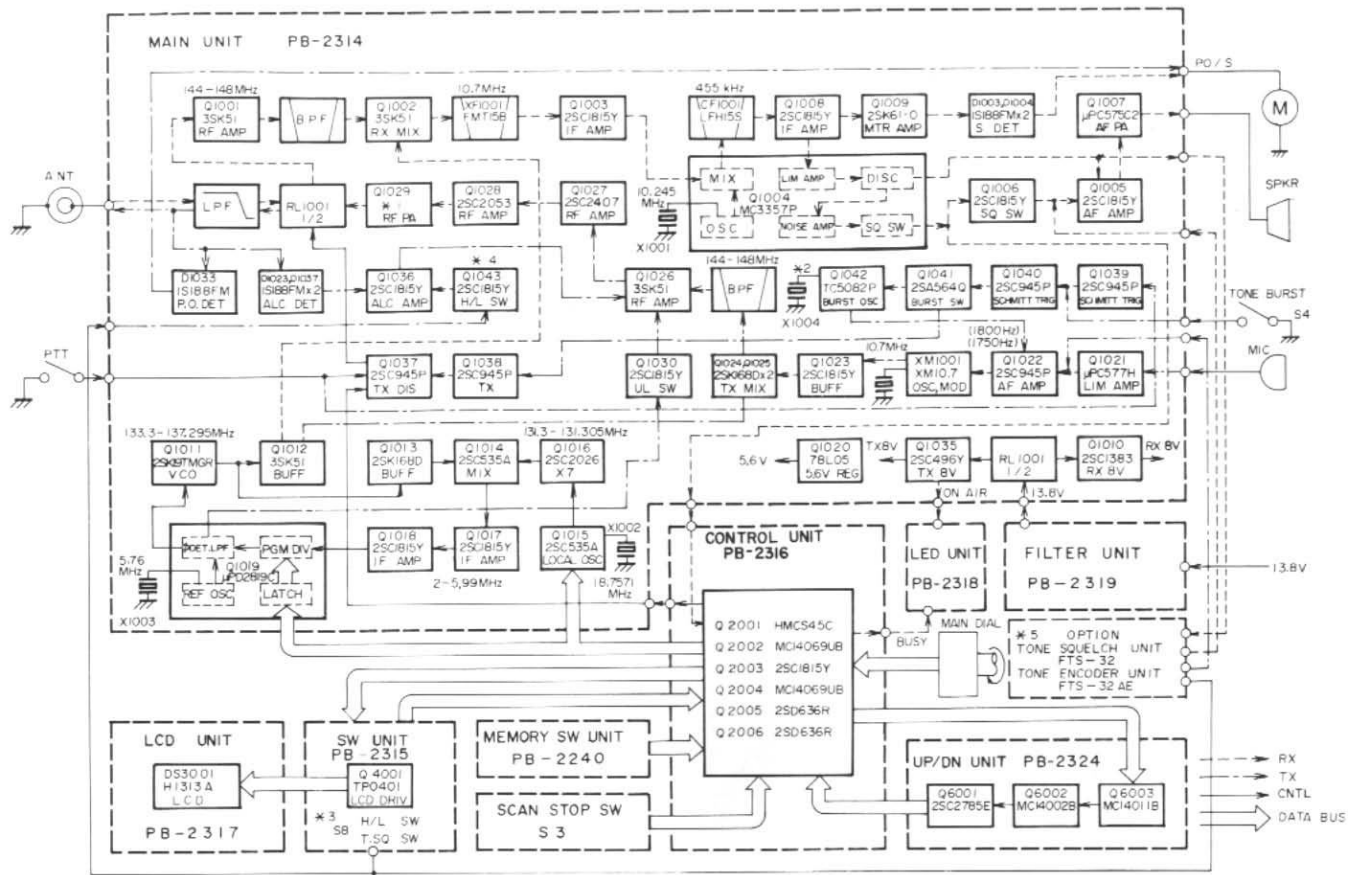

FT-230R 10W TYPE

FT-230R(H) 25W TYPE

	*1 Q1029	*2 X1004	*3 S8	*4 Q1043	*5 OPTION
MODEL A	RH1 M57712 R M57715	7.3728MHz (1180Hz)	T SQ ON/OFF	—	T. SQUELCH T. ENCODER
MODEL BCDE	RH0 M57712 R M57715	7.1680MHz (1175Hz)	POWER H/L	○	—

FT-230 R,R(H)  
BLOCK DIAGRAM

## CIRCUIT DESCRIPTION

This description together with the block diagram will provide you with a better understanding of your transceiver. Please refer to the schematic diagram for specific circuit details.

### RECEIVER

The RF signal from the antenna jack is fed through a lowpass filter and the antenna relay to RF amplifier  $Q_{1001}$  (3SK51-03) where the input signal is amplified with excellent rejection of inter- and cross modulation. The amplified signal is then fed through a five-section bandpass filter to remove any out-of-band signals, and to 1st RX mixer  $Q_{1002}$  (3SK51-03). Here the signal is mixed with the local signal delivered from the local oscillator buffer, and from which the 10.7 MHz product is used for the first IF signal.

This signal is filtered by 10.7 MHz monolithic crystal filter  $XF_{1001}$  (FMT-15B), with a bandwidth of 15 kHz, and then amplified by  $Q_{1003}$  (2SC1815Y) before being fed to the mixer section of  $Q_{1004}$  (MC3357P). Within  $Q_{1004}$  the 1st IF signal is mixed with an 10.245 MHz local signal generated in the IC's oscillator section, and the resulting 455 kHz product is then delivered through ceramic filter  $CF_{1001}$  (LF-H15S), which has a 15 kHz bandwidth, and 2nd IF amplifier  $Q_{1008}$  (2SC1815Y) to S-meter amplifier  $Q_{1009}$  (2SK61-O) and to the limiting amplifier section of  $Q_{1004}$ . This section of  $Q_{1004}$  removes amplitude variations on the signal and passes the signal to the discriminator section, which then produces an audio output in response to a corresponding shift in the 455 kHz IF signal.

When no carrier is present in the 455 kHz IF, the high frequency noise at the discriminator output, which passes through a bandpass filter, is amplified by the noise amplifier section of  $Q_{1004}$  and rectified by  $D_{1002}$  (1S1555). This DC voltage activates a switch within  $Q_{1004}$  which grounds the base of  $Q_{1006}$  (2SC1815Y), switching off the AF signal from the discriminator to the AF amplifier.

When a carrier is present in the 455 kHz IF, the noise is removed from the discriminator and the AF amplifier returns to normal operation.

The AF amplifier consists of  $Q_{1005}$  (2SC1815Y) and  $Q_{1007}$  ( $\mu$ PC575-C2), providing approximately 1 watt of audio output to the speaker.

## TRANSMITTER

The speech signal from the microphone is amplified and limited by  $Q_{1021}$  ( $\mu$ PC577H), and then fed through amplifier  $Q_{1022}$  (2SC945AP) to oscillator/modulator XM1001 (XM-10.7) where the 10.7 MHz oscillating frequency is modulated by the audio. The resulting 10.7 MHz FM signal is buffered by  $Q_{1023}$  (2SC1815Y) and applied to TX mixer  $Q_{1024}$  and  $Q_{1025}$  (2SK168D), where it is mixed with the 133.3 – 137.295 MHz local signal from local buffer  $Q_{1012}$  (3SK51-03).

The 144 MHz band product of the TX mixer is then passed through a bandpass filter to RF amplifier  $Q_{1026}$  (3SK51-03), which is controlled by the ALC signal and the unlock signal. From  $Q_{1026}$  the signal is further amplified by  $Q_{1027}$  (2SC2407) and  $Q_{1028}$  (2SC2053) before being applied to RF power amplifier module  $Q_{1029}$  (M57712 . . . 25W Model, or M57715 . . . 10W Model), which delivers 25/10 watts through relay  $RL_{1001}$  and a lowpass filter to the antenna connector.

### Tone Burst Circuit

When the T.CALL switch is pressed,  $Q_{1041}$  (2SA564Q) switches on 7.3728 MHz (or 7.168 MHz) burst oscillator  $Q_{1042}$  (TC5082P), which sends an 1800 Hz (or 1750 Hz) tone to audio amplifier  $Q_{1022}$  (2SC945AP) for as long as the switch is pressed.  $Q_{1038}$  (2SC945AP) grounds the PTT line, thus activating the transmitter.

### ALC and Power Control Circuits

A sample of the TX RF output signal is rectified by ALC detectors  $D_{1023}$  and  $D_{1037}$  (1S188FM) and then amplified by  $Q_{1036}$  (2SC1815Y) before being fed to gate two of TX RF amplifier  $Q_{1026}$ , controlling its gain. In models with a HI/LOW switch, transistor  $Q_{1043}$  (2SC945AP) feeds a control bias to  $Q_{1036}$  to select the low power level (Model: B, C, D, E, only). The ALC level is adjusted by  $VR_{1010}$  for proper gain at  $Q_{1026}$ .

## PLL Circuit

The PLL circuit is composed of a reference crystal oscillator, programmable divider, VCO (voltage controlled oscillator), PLL local mixer, PLL local oscillator, lowpass filter and a phase comparator. The PLL produces the local signal for the receiver and transmitter, using a synthesis scheme with 5 and 10 (or 12.5 and 25) kHz steps throughout the required frequency range.

The VCO, Q<sub>1011</sub> (2SK19TMGR), generates a signal between 133.3 and 137.295 MHz as determined by the capacitance of varactor diode D<sub>1006</sub> (1T25) adjusted by means of a control voltage from the phase detector/lowpass filter section of Q<sub>1019</sub> ( $\mu$ PD2819C).

The output signal from VCO Q<sub>1011</sub> is buffered by Q<sub>1012</sub> (3SK51-03) before being applied to RX mixer Q<sub>1002</sub> and TX mixer Q<sub>1024</sub> and Q<sub>1025</sub>. A sample of the output from VCO Q<sub>1011</sub> is also fed via buffer Q<sub>1013</sub> (2SK168D) to PLL local mixer Q<sub>1014</sub> (2SC535A), where it is mixed with the PLL local signal generated by Q<sub>1015</sub> (2SC535A) and multiplied by 7 at Q<sub>1016</sub> (2SC2026). The PLL local signal at the mixer has a frequency of around 131 MHz, while the PLL local oscillator, Q<sub>1015</sub>, has a frequency of around 18.7571 MHz determined by the control voltage from the CONTROL Unit (PB-2316). The 2 to 5.99 MHz product of PLL local mixer Q<sub>1014</sub> is amplified by PLL IF amplifiers Q<sub>1017</sub> and Q<sub>1018</sub> (2SC1815Y) before being applied to the programmable divider section of Q<sub>1019</sub> ( $\mu$ PD2819C), where the PLL IF signal is divided by 200 to 599, according to data from the 4-bit microprocessor in the CONTROL Unit, to provide a 10 kHz product.

Within Q<sub>1019</sub> the 10 kHz signal is passed from the programmable divider to the phase comparator section, where the 10 kHz product of the IF signal is compared with the 10 kHz reference signal generated in the reference oscillator section of Q<sub>1019</sub> from the 5.76 MHz crystal (appropriately divided). Any difference in phase between the 10 kHz product of the IF and the 10 kHz from the reference oscillator produces an error correcting signal that is rectified and fed through the lowpass filter section of Q<sub>1019</sub> to be delivered back to the varactor diode in the VCO circuit.

Whenever the PLL is unlocked a signal from pin 7 of  $Q_{1019}$  activates Unlock Switch  $Q_{1030}$  (2SC1815Y), which then shuts off TX RF amplifier  $Q_{1026}$ , removing the signal from the rest of the RF amplifier stages.

### PLL Control Circuit

The Control Unit, PB-2316, features a low current drain 4-bit microprocessor,  $Q_{2001}$  (HD44820-A18), which processes data for controlling the operating frequency, UP/DOWN scanning, priority channel, memory selection, and etc. The CPU accepts input data by means of the main dial or other control switches in accordance with the program stored in its ROM for control of the PLL frequency and display functions.

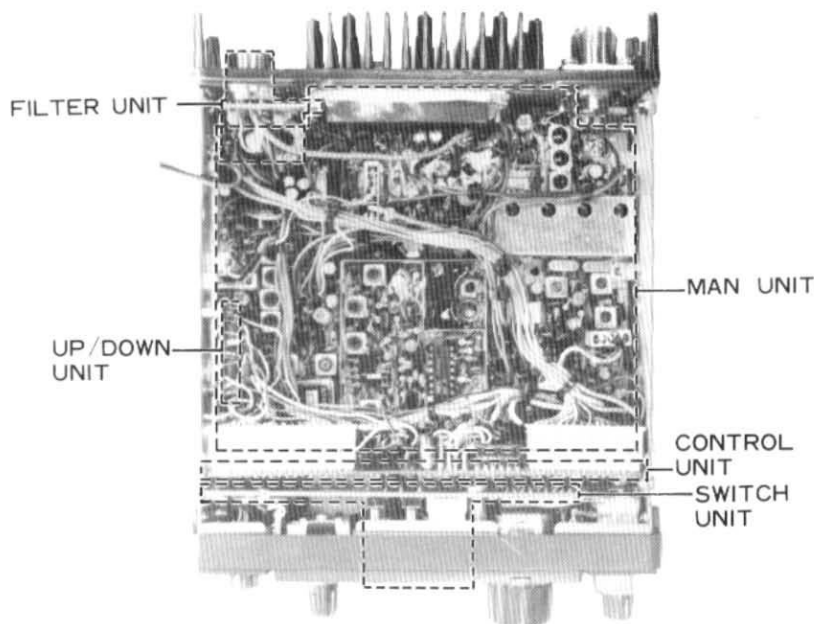

BOTTOM VIEW

# MAINTENANCE AND ALIGNMENT

This equipment has been carefully aligned and tested at the factory prior to shipment. If the instrument is not abused, it should not require other than the usual attention given to electronic equipment.

Service or replacement of a major component may require considerable realignment. Under no circumstances, though, should realignment be attempted unless the operation of the transceiver is fully understood, the malfunction has been carefully analyzed, and the fault has definitely been traced to misalignment rather than part failure. Service work must only be performed by experienced personnel using the proper test equipment.

Never align this transceiver without having a 50 ohm dummy load connected to the antenna jack. Troubleshooting using an antenna can result in misleading indications on the test equipment.

## EQUIPMENT REQUIRED

1. RF Signal Generator: Hewlett-Packard Model 8640B or equivalent with one volt output at 50 ohms and frequency coverage to 150 MHz.
2. Vacuum Tube Voltmeter (VTVM): Hewlett-Packard Model 410B or equivalent.
3. Dummy Load/Wattmeter: Yaesu YP-150Z or equivalent.
4. AF Signal Generator: Hewlett-Packard Model 200AB or equivalent.
5. IF Sweep Generator: capable of output at 10.7 MHz.
6. RF Sweep Generator: capable of output at 143 – 149 MHz.
7. Oscilloscope: Hewlett-Packard Model 1740A or equivalent.
8. FM Deviation Meter: coverage to 144 – 148 MHz.
9. Precision Frequency Counter: Yaesu Model YC-500E or equivalent with resolution to 0.01 kHz and frequency coverage to 150 MHz.

## PLL CIRCUIT ALIGNMENT

Because of certain thermally sensitive, interacting components in the PLL circuitry, particular attention must be paid to assure a constant ambient temperature at the circuit during alignment. If the transceiver temperature is more than a few degrees different than that of the alignment environment, allow several hours for thermal equalization. Alignment temperature must be held constant and be within the range of 15 to 30°C.

### A. PLL IF, VCV (Varactor Control Voltage)

1. Set the transceiver frequency to the center of the band (146.000.0 MHz for Models A, C, D, and E; 145.000.0 MHz for Model B). Connect the RF probe of the voltmeter to pin 14 of Q<sub>1019</sub>.
2. Adjust T<sub>1007</sub> and T<sub>1008</sub> for maximum voltmeter deflection (300 mVrms nominal).
3. Connect the DC voltmeter to the VCV line at R<sub>1092</sub>, and set the transceiver to 144.000.0 MHz. Check for 1.5 VDC on the voltmeter.
4. Tune the transceiver to the frequency listed for the Model being aligned as per the chart below, and check for 3.0 or 4.0 VDC as indicated.

MODEL	A, D, E	B	C
Freq. Set (MHz)	147.9950	145.9875	147.9875
Q <sub>1019</sub> , pin 12 (VDC)	4.0	3.0	4.0

5. Tune the transceiver to the band center and connect the RF probe of the voltmeter to the cathode of D<sub>1008</sub>. Adjust T<sub>1006</sub> for maximum deflection.

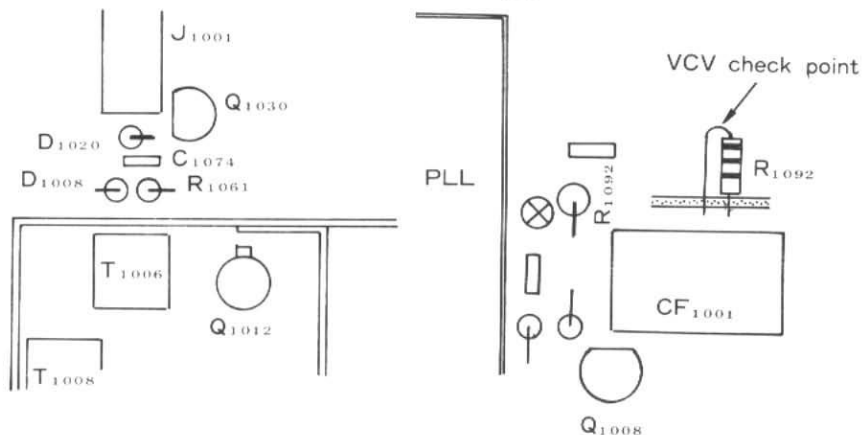
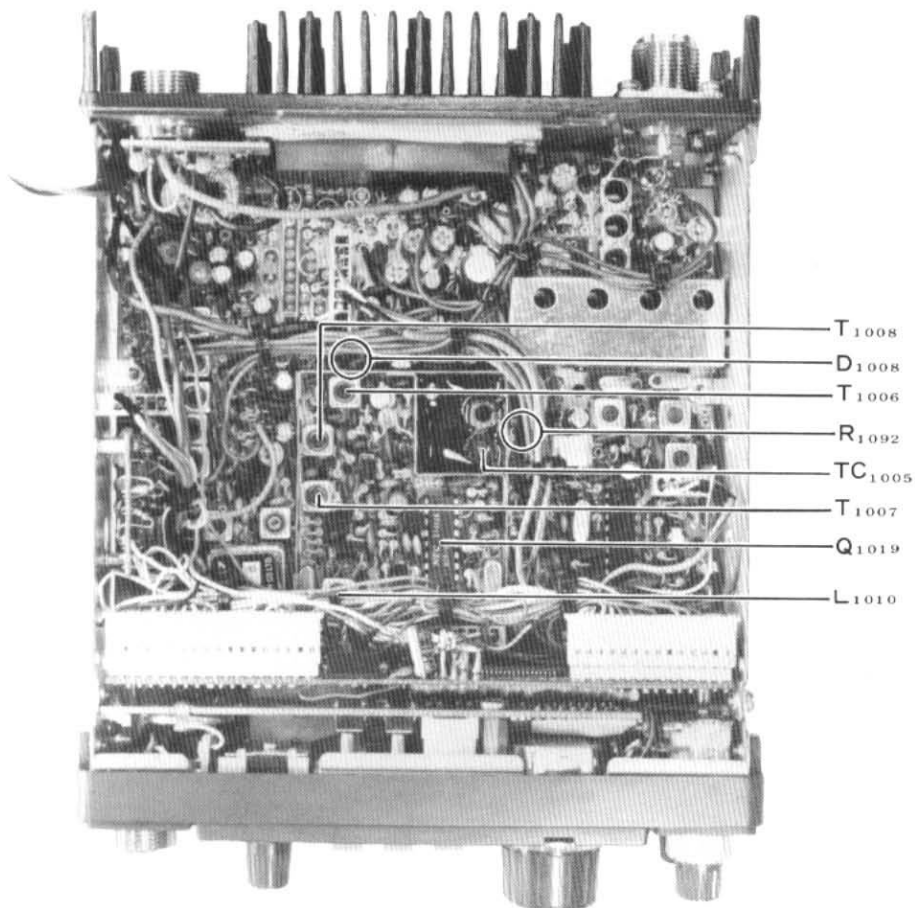

PLL SECTION ALIGNMENT POINTS

## B. PLL Frequency

1. Connect the frequency counter to the cathode of  $D_{1008}$ , and preset  $VR_{1003}$  to its center position.  $VR_{1004}$  is course tuning, while  $VR_{1003}$  is fine, so make the following adjustments with  $VR_{1004}$  first, fine tuning with  $VR_{1003}$  to within  $\pm 100$  Hz of the frequency indicated in the chart. Also adjust  $L_{1010}$  to within the same tolerance.

MODEL	A, D, E		B, C	
DISPLAY FREQ	6.000.0	5.995.0	5.000.0	4.987.5
$D_{1008}$ (Cath Freq., MHz.)	135.300	134.295	134.300	134.2875
ADJ. POINT	$L_{1010}$	$VR_{1003}$ , $VR_{1004}$	$L_{1010}$	$VR_{1003}$ , $VR_{1004}$

## RECEIVER

### A. RF, IF Circuits

1. Connect the SSG (standard signal generator) to the antenna terminal, and the SINAD meter to the EXT SP terminal with an 8 ohm resistor to ground.
2. Set the transceiver frequency to the band center, and preset  $VR_{1001}$  fully clockwise (max.). Do not set the SSG frequency to this point yet.
3. With the SINADER measuring AC millivolts, adjust  $T_{1005}$  for maximum meter indication.
4. Now set the output level of the SSG to 40 to 60 dB $\mu$  and, with no modulation, set the SSG frequency to the exact center of the transceiver frequency. Do not tune for signal peak, because of passband ripple.
5. Modulate the SSG output with 70% (3.5 kHz) deviation of a 1 kHz tone, and connect the DC voltmeter (0.25 V scale) to the cathode of  $D_{1004}$ .
6. Keeping the DC voltmeter on this scale by adjusting the output level of the SSG, adjust  $TC_{1001}$ ,  $TC_{1002}$ ,  $TC_{1003}$ ,  $TC_{1004}$  and  $T_{1001}$ ,  $T_{1002}$ ,  $T_{1003}$  and  $T_{1004}$  for a peak on the DC voltmeter.

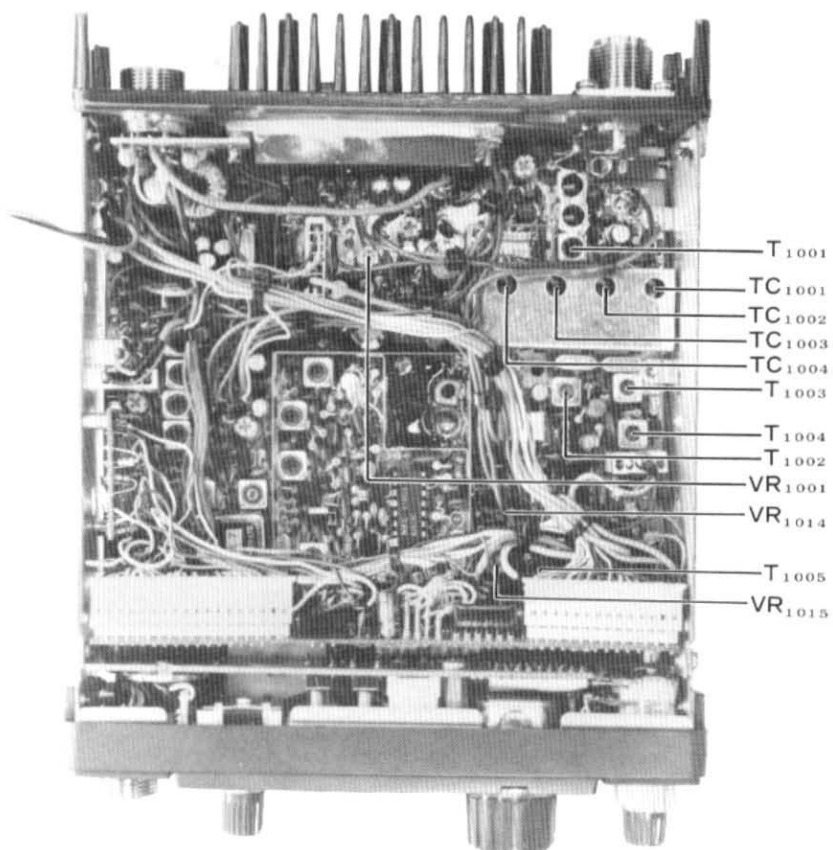

RECEIVER SECTION ALIGNMENT POINTS

## B. Sensitivity

1. With the same test equipment set up as in part A, vary the SSG output level until the SINAD meter (in the AC millivolt function) indicates  $-12 \text{ dB}\mu$ . Check that the SSG level is less than  $-6 \text{ dB}\mu$  at the center of the band.
2. Repeat this check at the upper and lower band edges.

## C. S-Meter

1. With the same setup as in part A, set the SSG output level to  $0 \text{ dB}\mu$ .
2. Adjust  $\text{VR}_{1014}$  for S-1 on the S-meter.
3. Increase the SSG level to  $40 \text{ dB}\mu$ , and check that the S-meter reading is at least S9+20  $\text{dB}\mu$ .

## D. SQL Control Preset

1. Set the SQL control to the 12 o'clock position.
2. Adjust  $\text{VR}_{1015}$  for the squelch threshold point with no signal on the frequency.

## TRANSMITTER

### A. Output Power

1. Connect the terminated wattmeter to the ANT terminal, and preset  $\text{TC}_{1006}$ ,  $\text{TC}_{1007}$  and  $\text{TC}_{1008}$  to their center positions, and  $\text{VR}_{1010}$  fully counterclockwise (minimum).
2. Adjust  $\text{T}_{1011}$  through  $\text{T}_{1015}$  for peak output, detuning  $\text{T}_{1010}$  if necessary to observe the peak on the wattmeter.
3. Do likewise with  $\text{TC}_{1006}$ ,  $\text{TC}_{1007}$  and  $\text{TC}_{1008}$ , and finally peak  $\text{T}_{1010}$ .
4. At band center, the 10 watt models should show at least 16 watts output, while the 25 watt models should show at least 28 watts output. At band edges, the 10 watt models should show at least 15 watts; and the 25 watt models, 27 watts.

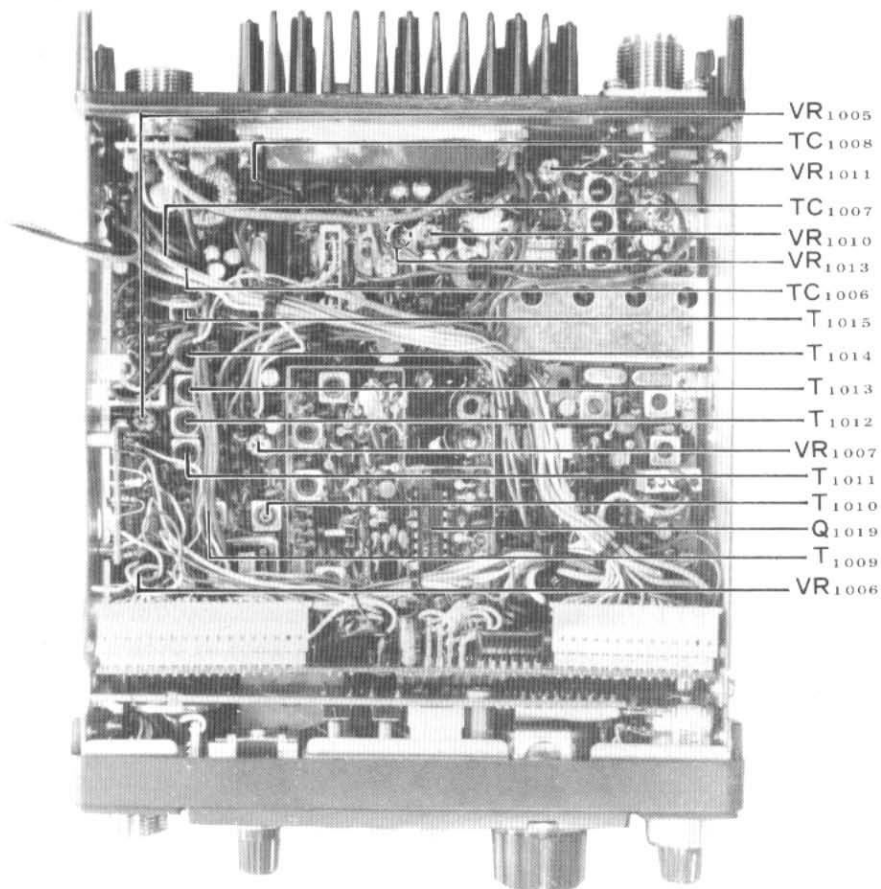

TRANSMITTER SECTION ALIGNMENT POINTS

## B. P. O. Meter

1. At band center, adjust VR<sub>1010</sub> for 12 watts output on the 10 watt models, or 27 watts output on the 25 watt models.
2. Adjust VR<sub>1011</sub> for a reading of 8 on the transceiver's PO meter.
3. At the band edges, check the 10 watt models for 11 watts output or the 25 watt models for 26 watts output with, in all models, a PO meter indication of 7.5 to 8.5.

## C. LO Power (for models equipped with HI/LO function)

1. At band center adjust VR<sub>1013</sub> for 3 watts output (25W model) or 1 watt (for 10W model).
2. Check band edges for 3 watts (or 1 watt)  $\pm 0.5$  watt output. The transceiver's PO meter should indicate  $2 \pm 0.5$ .

## D. Modulation

1. Connect the test equipment as shown below. Preset VR<sub>1005</sub> to the center of its range, and set the AF generator output level to 15 mV at 1 kHz.
2. Close the PTT line and adjust VR<sub>1006</sub>, if necessary, for 4.5 kHz deviation. The oscilloscope should display a sine wave as shown below.
3. Reduce the AF generator output level to 1.5 mV and adjust VR<sub>1005</sub> for 3.5 kHz deviation.

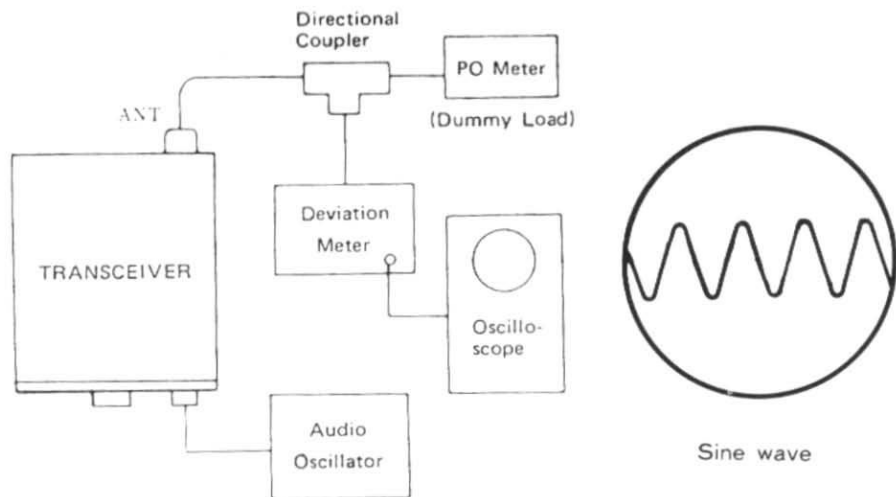

### **E. Tone Burst**

1. Connect the deviation meter and frequency counter to the SP jack (with the 8 ohm resistor to ground).
2. Depress the T.CALL switch and check for  $3.5 \pm 0.5$  kHz deviation on the meter.
3. Check the frequency counter for  $1800 \pm 1$  Hz for model A, or  $1750 \pm 1$  Hz for models B, C, D, and E.
4. With a monitor receiver at the same frequency as the transceiver, check for a 0.5 second burst when the PTT is closed and the Burst switch (rear panel) on.

### **F. Spurious Generation**

1. Connect the spectrum analyzer to the ANT terminal.
2. Adjust  $VR_{1007}$  for minimum spurious at 10.7 MHz. The spurious signals should then be at least -60 dB from the power output level at the band edges as well as at band center.

### **G. Reduced Voltage Check**

1. Connect the wattmeter and the spectrum analyzer to the ANT terminal.
2. Set the supply voltage to 11.5 VDC and check for 10 watts output on the 10 watt models, or 20 watts output on the 25 watt models. Check the spectrum analyzer for any oscillations in the band.
3. Set the supply voltage to 16 VDC and check as above for 13 watts or 28 watts, respectively, and again for oscillations in the band.
4. With a monitor receiver check the transceiver for clear, stable signal quality with 11.5 and then 16 VDC supplied to the transceiver.

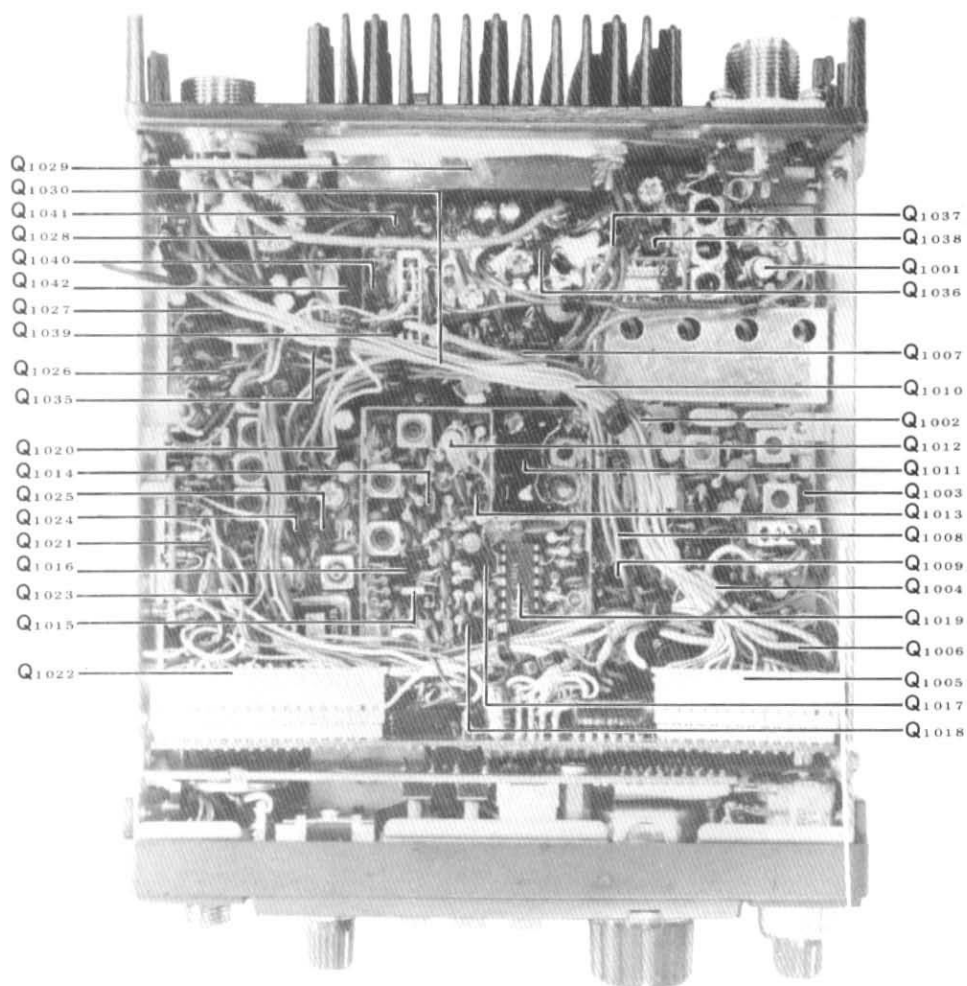

MAIN UNIT

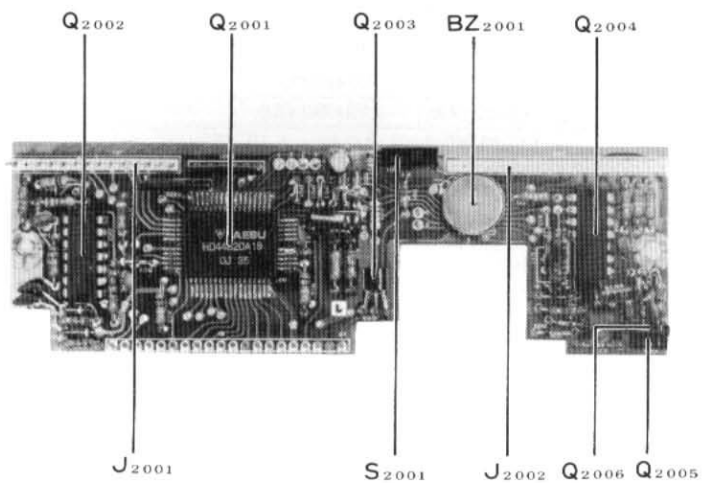

CONTROL UNIT

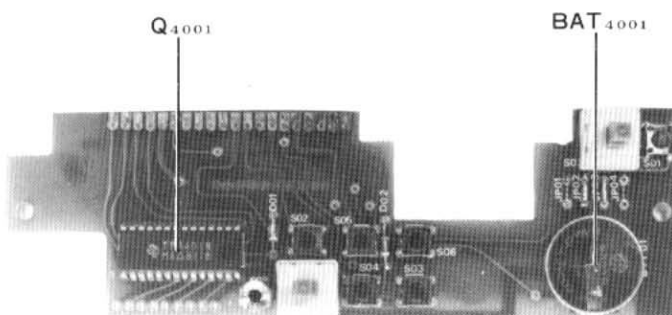

SWITCH UNIT

# PARTS LIST

MAIN CHASSIS		
Symbol No.	Part No.	Description
		LED
D1	G2090209	BG-4632K
D2	G2090208	PR-4632K
PB-2318A	F0002318A	LED BOARD
	C0023180	P.C.B with D1,D2
		RESISTOR
R1	J10216101	Carbon composition $\frac{1}{8}$ W GK 100 $\Omega$
R2	J01245680	film * TJ 68 $\Omega$
		POTENTIOMETER
VR1(with S8)	J62800057	K12B61004-5N1211-5KB-10KA
		CAPACITOR
C1	K02175150	Ceramic disc 50WV CH 15pF (DD 104CH150J50V02)
C2	K12171102	Ceramic disc 50WV E 0.001 $\mu$ F (DD105E102P50V02)
		INDUCTOR
L1	L0020853	
		SWITCH
S1 (with VR1)		
S2	Q9000115	EWX-XDS2050B
S3	N0190095	SRU-1023N
S4	N6090010	SSF-22-55
S5	N6090011	SSH-23-05
S6	N0190084	SRS-101C
PB-2240	F0002240	SWITCH BOARD
	C0022400	P.C.B with S6
		CONNECTOR
J1	P0090243	FM214-7SS
J2	P1090192	FM-MR
J4	P0090244	FM-214-2S
J3	P1090005	SG-8050

METER		
M1	M0290029	AP-120-3730
SPEAKER		
SP1	M4090052	VS-77 8Ω 1W
	T9100302	Speaker Cord (RED)
	T9100305	Speaker Cord (BLACK)
CONNECTER		
P1 (with wire)	T9204291A	5208-08
P2 (with wire)	T9204292	5208-13
P3 (with wire)	T9204294A	5208-04
P4	P1090258	5208-04
P5 (with wire)	T9204295	5208-04
P7 (with wire)	T9204293	5208-17
P8▲(with wire)	T9204408	
KNOB		
	R3073810	FT-11UK VOL
	R3073820	FT-15UDS SQL
	R3073830	FT-13UTK RPT
	R3073850	FT-26T TUNING KNOB
MAIN UNIT		
Symbol No.	Part No.	Description
PB-2314D	F0002314D	Printed Circuit Board
	C0023140	P.C.B. with Components
IC		
Q1020	G1090084	78L05
Q1004	G1090145	MC3357P
Q1007	G1090073	μPC575C2
Q1021	G1090072	μPC577H
Q1019	G1090237	μPD2819C
Q1042	G1090239	TC5082P
Q1029(10W Model)●	G1090251	M57715
Q1029(25W Model)○	G1090252	M57712

●10W model

○25W model

		TRANSISTOR	
Q1041	G3105641Q	2SA564Q	
Q1022,1037-1040	G3309451P	2SC945AP	
Q1035	G3304960Y	2SC496Y	
Q1014,1015	G3305350A	2SC535A	
Q1010	G3313830	2SC1383	
Q1003,1005,1006, 1008,1017,1018, 1023,1030,1036,1043★	G3318150Y	2SC1815Y	
Q1016	G3320260	2SC2026	
Q1028	G3320530	2SC2053	
Q1027	G3324070	2SC2407	
		FET	
Q1011	G3090035	2SK19TM-GR	
Q1009	G38006100	2SK61-0	
Q1013,1024,1025	G3801680	2SK168 (D,E,F)	
Q1001,1002,1012, 1026	G4800510C	3SK51-03	
		DIODE	
D1002,1010,1012,1040★	G2015550	Si	1S1555
D1007,1008,1011 1020,1025-1029, 1031,1032,1034, 1038,1039,1042	G2090027	∞	1SS53
D1003,1004,1023, 1033,1037★	G2001880F	Ge.	1S188FM
D1009	G2090108	Varactor	1SV68
D1014-1018	G2090109	∞	1SV69
D1006	G2090107	∞	1T25
D1035	G2090007	Zener	WZ061
D1005,1022	G2090010	∞	WZ090
D1041	G9090006	Varistor	MV13
		CRYSTAL	
X1003	H0101986	HC-18/T	5.76MHz
X1001	H0100720A	HC-18/U	10.245MHz
X1002	H0102435	HC-18/TU	18.7571MHz
X1004(1800Hz Tone)	H0101983	HC-18/TU	7.3728MHz
X1004(1750Hz Tone)	H0101982	HC-18/TU	7.168MHz
		CRYSTAL FILTER	
XF1001	H1102013	FMT-15B	

▲model A

★model BCDE

		CERAMIC FILTER			
CF1001	H3900204	LFH-15S			
		MODULATOR MODULE			
XM1001	H9500320	XM-10.7	10.7MHz		
		RESISTOR			
R1128	J02245569	Carbon Film	¼W	SJ	5.6Ω
R1049,1166	J02245220	◇ ◇	◇ ◇		22Ω
R1004,1008,1057, 1097,1119,1181	J02245560	◇ ◇	◇ ◇		56Ω
	J10246560	◇ composition	¼W	GK	56Ω
R1047	J02245820	◇ Film	◇	SJ	82Ω
R1005,1010,1015, 1032,1053,1058, 1063,1076,1102, 1106,1111,1124, 1167	J02245101	◇ ◇	◇ ◇		100Ω
R1052	J02245151	◇ ◇	◇ ◇		150Ω
R1030	J02245181	◇ ◇	◇ ◇		180Ω
R1072,1094,1122, 1147	J02245221	◇ ◇	◇ ◇		220Ω
R1170	J10246221	◇ composition	◇	GK	220Ω
R1048,1075,1140	J02245471	◇ Film	◇	SJ	470Ω
	J10246561	◇ composition	◇	GK	560Ω
R1100,1121,1182	J02245561	◇ Film	◇	SJ	560Ω
R1159	J02245681	◇ ◇	◇ ◇		680Ω
R1160	J02245821	◇ ◇	◇ ◇		820Ω
R1014,1018,1030, 1031,1067,1070 1171,1079,1080, 1082,1096,1105, 1151	J02245102	◇ ◇	◇ ◇		1kΩ
R1101	J01245102	◇ ◇	◇	TJ	1kΩ
	J10246102	◇ composition	◇	GK	1kΩ
R1041,1155	J02245122	◇ Film	◇	SJ	1.2kΩ
R1022,1066	J02245152	◇ ◇	◇ ◇		1.5kΩ
R1034,1084,1173	J02245182	◇ ◇	◇ ◇		1.8kΩ
R1035,1039,1043, 1059-1061,1078, 1083,1095,1126, 1154,1183	J02245222	◇ ◇	◇ ◇		2.2kΩ
R1012	J02245332	◇ ◇	◇ ◇		3.3kΩ
R1085	J02245392	◇ ◇	◇ ◇		3.9kΩ
R1020,1180▲	J02245472	◇ ◇	◇ ◇		4.7kΩ

R1177	J02245562	Carbon Film	1/4W	SJ	5.6kΩ
R1009,1011	J02245682		∗	SJ	6.8kΩ
R1024, 1050, 1064, 1087, 1143,1144,1148—1150, 1150,1152,1168	J02245103	∗ ∗	∗ ∗		10kΩ
R1021	J10246153	∗ composition	∗	GK	15kΩ
R1023	J02245153	∗ Film	∗	SJ	15kΩ
R1013	J02245183	∗ ∗	∗	SJ	18kΩ
R1002,1003,1029, 1068,1071,1073, 1089—1091,1098, 1103,1169,1175	J02245223	∗ ∗	∗ ∗		22kΩ
R1016	J01245223	∗ ∗	∗	TJ	22kΩ
R1026	J02245333	∗ ∗	∗	SJ	33kΩ
R1065	J02245393	∗ ∗	∗ ∗		39kΩ
R1006,1007,1025, 1033,1037,1044, 1069,1074,1099, 1104,1107,1108	J02245473	∗ ∗	∗ ∗		47kΩ
R1115	J01245473	∗ composition	∗	GK	47kΩ
R1036	J02245563	∗ Film	∗	SJ	56kΩ
R1017,1028	J02245823	∗ ∗	∗ ∗		82kΩ
R1054—1056,1062, 1109,1110,1112, 1114,1116,1118— 1145,1153,1178	J02245104	∗ ∗	∗ ∗		100kΩ
R1092	J10246104	∗ composition	∗	GK	100kΩ
R1046	J02245124	∗ Film	∗	SJ	120kΩ
R1045,1081,1113	J02245154	∗ ∗	∗ ∗		150kΩ
R1038	J02245224	∗ ∗	∗ ∗		220kΩ
R1019,1077,1163	J02245274	∗ ∗	∗ ∗		270kΩ
R1162	J02245334	∗ ∗	∗ ∗		330kΩ
R1051,1146	J02245474	∗ ∗	∗ ∗		470kΩ
R1088,1134	J02245105	∗ ∗	∗ ∗		1MΩ
R1133	J02245155	∗ ∗	∗ ∗		1.5MΩ
		<b>POTENTIOMETER</b>			
VR1007	J51745471	H0651A 005-470B			470ΩB
VR1006,1010	J51745102	∗	007-1KB		1kΩB
VR1001	J51745472	∗	011-4.7 KB		4.7kΩB
VR1005,1013★	J51745103	∗	013-10KB		10kΩB
VR1013(25W Model)	J51745223	∗	015-22KB		22kΩB
VR1003,1011,1015	J51745473	∗	017-47KB		47kΩB
VR1014	J51745104	∗	019-100KB		100kΩB
VR1004	J51745154		020-150KB		150kΩB

		<b>THERMISTOR</b>
TH1002	G9090008	31D26
		<b>CAPACITOR</b>
C1093,1146,1213	K00179001	Ceramic Disc 50WV SL 0.5pF (DD104SL0R5C50V02)
C1089	K00172010	〃 〃 〃 〃 1pF (DD104SL010C50V02)
C1001	K02179001	〃 〃 〃 CH 1pF (DD104CK010C50V02)
C1140,1145,1148 1188(10W),1189	K02179003	〃 〃 〃 〃 2pF (DD104CK020C50V02)
	K00172020	〃 〃 〃 SL 2pF (DD104SL020C50V02)
C1016,1160,1176●	K02179004	〃 〃 〃 CH 3pF (DD104CH030C50V02)
C1063	K06172030	〃 〃 〃 UJ 3pF (DD104UJ030J50V02)
C1067	K00172030	〃 〃 〃 SL 3pF (DD104SL030C50V02)
C1188▲	K02172040	〃 〃 〃 CH 4pF (DD104CH040C50V02)
C1011,1219	K02172050	〃 〃 〃 CH 5pF (DD104CH050C50V02)
C1010-1013	K06175050	〃 〃 〃 UJ 5pF (DD104UJ050C50V02)
C1066,1079,1080	K00172050	〃 〃 〃 SL 5pF (DD104SL050C50V02)
C1058,1144,1149, 1152,1157	K06173060	〃 〃 〃 UJ 6pF (DD104UJ060J50V02)
C1143,1151	K00173060	〃 〃 〃 SL 6pF (DD104SL060D50V02)
C1092,1094	K02173080	〃 〃 〃 CH 8pF (DD104CH080D50V02)
C1139,1141	K06173080	〃 〃 〃 UJ 8pF (DD104UJ080D50V02)
C1035,1164,1188 (25W)	K02173100	〃 〃 〃 CH 10pF (DD104CH100D50V02)
C1057	K05175120	〃 〃 〃 RH 12pF (DD104RH120J50V02)
C1061,1232●	K02175120	〃 〃 〃 CH 12pF (DD104CH120J50V02)
C1062	K06175120	〃 〃 〃 UJ 12pF (DD104UJ120D50V02)
C1185,1232○	K02175150	〃 〃 〃 CH 15pF (DD104CH150J50V02)

●10W model  
○25W model

C1199	K00175150	Ceramic Disc 50WV SL 15pF (DD104SL150J50V02)
C1006,1009	K06175150	“ “ “ UJ 15pF (DD104UJ150J50V02)
C1176 °	K02175180	“ “ “ CH 18pF (DD104CH180J50V02)
C1007,1008	K06175180	“ “ “ UJ 18pF (DD104UJ180J50V02)
C1135,1136,1163	K02179009	“ “ “ CH 22pF (DD104CH220J50V02)
C1134	K00175270	“ “ “ “ 27pF (DD2179012 (DD104SL270J50V02)
C1186,1187	K02179012	“ “ “ CH 30pF (DD105CH300J50V02)
C1105,1106,1154	K02179013	“ “ “ “ 33pF (DD105CH330J50V02)
C1032,1197,1198	K00175330	“ “ “ SL 33pF (DD104SL330J50V02)
C1030	K02175470	“ “ “ CH 47pF (DD106CH470J50V02)
	K00179010	“ “ “ SL 51pF (DD104SL510J50V02)
C1095,1096	K00175560	“ “ “ “ 56pF (DD104SL560J50V02)
	K06175680	“ “ “ UJ 68pF (DD105-257UJ680J50V02)
C1131,1229	K00175101	“ “ “ 100pF (DD105SL101J50V02)
C1086,1087	K06175101	“ “ “ 100pF (DD106UJ101J50V02)
C1031	K02175121	“ “ “ CH 120pF (DD109CH121J50V02)
C1084	K06175181	“ “ “ UJ 180pF (DD104UJ181J50V02)
C1098	K00175331	“ “ “ SL 330pF (DD107SL331J50V02)
C1003-1005, 1014, 1017, 1019, 1054 1064, 1069-1071, 1073-1078, 1083, 1090, 1091, 1103, 1108-1110 1118, 1119, 1127, 1129, 1142, 1147, 1150, 1155, 1156, 1159, 1162, 1165, -1168, 1173, 1175, 1177, 1183, 1184, 1190, 1191, 1196, 1203, 1205, 1206, 1210, 1211, 1217, 1218, 1220★, 1221★, 1225, 1226, 1230, 1231▲	K12171102	“ “ “ 0.001μF (DD105E102P50V02)

C1024,1025,1047	K19149001	Semiconductor Ceramic 25WV (UTA04×102K-L05AE)	0.001μF
C1020,1039,1041,1042, 1081,1082,1085,1097, 1099,1100,1111,1130, 1132,1137,1138,1133, 1180,1194,1204,1208	K13170130	Ceramic Disc 50WV (DB201YF103Z5L5)	0.01μF
C1029,1034,1036, 1037,1214,1227, 1234	K19149017	Semiconductor Ceramic 25WV X (UAT06×223K-L45AE)	0.022μF
C1015,1018,1038,1040, 1056,1068,1124,1125, 1170,1207,1224,1228	K19149021	“ “ “ (UAT08X473K-45AE)	0.047μF
C1021,1044,1049	K19149025	“ “ “ (UAT13X104K-L46AE)	0.1μF
C1023	K40179016	Electrolytic 50WV RE (50RE0R1)	0.1μF
C1233	K40179002	“ “ “ (50RC2-0R1)	RC2 0.1μF
C1116	K40179005	“ “ “ (50RC2R47)	RC2 0.47μF
C1026,1033,1052, 1126,1128,1200	K40179013	“ “ “ (50RE1)	1μF
C1043	K40179001	“ “ “ (ECE-A1HK010 50V1)	RC2 1μF
C1022	K40179012	“ “ “ (50RE4R7)	RE 4.7μF
C1045	K40179008	“ “ “ (ECE-A1HK4R7 50V4R7)	RC2 4.7μF
C1193	K40129026	“ “ “ (16RE4R7)	16WV RE 4.7μF
C1216	K40129012	“ “ “ (ECE-A1CK100 16V10)	RC2 10μF
C1028,1053,1055, 1065,1107,1112, 1113,1117,1120- 1123,1161,1171 1172,1174,1179, 1181,1212,1223	K40129004	“ “ “ (16RE10)	RE 10μF
C1051	K40109002	Electrolytic 10WV RE (10RE47)	47μF
C1050	K40129007	“ “ “ (16RE100)	16WV “ 100μF
C1046	K40109013	“ “ “ (10RC330)	10WV “ 330μF

C1048	K40109004	Electrolytic (10RE470)	10 WV RE	470 $\mu$ F
C1115	K40129021	Electrolytic (16R102S 13 $\times$ 16)	16 WV	1000 $\mu$ F
C1195	K70167104	Tantalum (CS15E1V0R1M)	35 WV	0.1 $\mu$ F
C1101,1102	K70107106	◇ (CS15E1A100M)	10 WV	10 $\mu$ F
C1104	K70167474	◇ (CS15E1VR47)	35 WV	0.47 $\mu$ F
		TRIMMER CAPACITOR		
TC1005	K91000056	TZ03Z070A		7pF
TC1001-1004	K91000028	ECV1ZW 10 $\times$ 53		10pF
TC1006-1008	K91000029	ECV1ZW 20 $\times$ 53		20pF
		INDUCTOR		
L1007	L1190004	FL4H-R68M		0.68 $\mu$ H
L1001	L1190008	FL4H-2R2M		2.2 $\mu$ H
L1005,1011	L1190014	FL4H-100K		10 $\mu$ H
L1003	L1190016	FL5H-101K		100 $\mu$ H
L1012	L1190102	S-104K		100mH
L1014,1020	L1020469			
L1021	L1020663			
L1008	L1020680			
L1002	L0020302			
L1006	L0020359A			
L1010	L0020950			
L1022,1023	L0020679			
L1024 ●	L0021215			
L1024 ○	L0021216			
		TRANSFORMER		
T1001	L0021143			
T1002-1004,1009	L0021162			
T1010	L0020910A			
T1005	L0020188			
T1006-1008,1011-1015	L0020345			
		COIL CASE		
	L9190016			
		Wrapping Terminal		
	Q5000038			TP-I

● 10W model

○ 25W model



R2020,2021	J01245682	Carbon Film	¼W	TJ	6.8kΩ
	J01215822	◇ ◇	⅛W	◇	8.2kΩ
R2018,2024	J01245103	◇ ◇	¼W	◇	10kΩ
R2007	J01245223	◇ ◇	◇	◇	22kΩ
R2002	J01245333	◇ ◇	◇	◇	33kΩ
R2017	J01245473	◇ ◇	◇	◇	47kΩ
R2022,2023	J01215563	◇ ◇	⅛W	◇	56kΩ
R2003,2005,2006	J01245104	◇ ◇	¼W	◇	100kΩ
R2025★	J01245224	◇ ◇	◇	◇	220kΩ
R2011,2014,2015	J01245334	◇ ◇	◇	◇	330kΩ
R2012	J01215334	◇ ◇	⅛W	◇	330kΩ
R2016	J01245684	◇ ◇	¼W	◇	680kΩ
R2013	J01215684	◇ ◇	⅛W	◇	680kΩ
R2009,2010	J01215105	◇ ◇	◇	◇	1MΩ
R2004	J01245105	◇ ◇	¼W	◇	1MΩ
		<b>BLOCK RESISTOR</b>			
RB2001	J40900022	DA-1			
RB2002	J40900023	DA-2			
		<b>THERMISTOR</b>			
TH2001	G9090016	33D28			
		<b>CAPACITOR</b>			
C2001	K10176391	Ceramic Disc (DD104B391K50V02)	50VV	B	390pF
C2002,2004	K12171102	◇ ◇ (DD105E102P50V02)	◇	E	0.001μF
C2006,2008,2009, 2013,2014	K19149009	Semiconductor Ceramic (UAT05X472K-L05AE)	◇		0.0047μF
C2007,2012	K19149013	◇ ◇ (UAT05X103K-L05AE)			0.01μF
C2003,2005	K40129004	Electrolytic (16RE10)	16VV		10μF
C2010,2011,2015, 2016★	K40129012	◇ (ECE-A1CK100 16V10)	◇	RC2	10μF
		<b>INDUCTOR</b>			
L2001	L1190017	FL5H-102K			1mH

		<b>SWITCH</b>		
S2001	N6090008	SSS-012		
		<b>BUZZER</b>		
BZ2001	M4290001	EFBRE-25 D02		
		<b>CONNECTOR</b>		
J2001	P0090039	5048-13A		
J2002	P0090055	5048-17A		
J2003	P0090218	5045-02A		
J2004	P0090220	5045-04A		
	Q5000011	Wrapping Terminal C		
PB-2318A★	F0002318A	REVERSE BOARD		
	C0023181	P.C.B with Q2007,D2010,D2011,R2025,C2016		
<b>LCD UNIT</b>				
	<b>Symbol No.</b>	<b>Part No.</b>	<b>Description</b>	
	PB-2317A	F0002317A	Printed Circuit Board	
		C0023170	P.C.B. with components	
			<b>LCD</b>	
	DS3001	G6090025	H1313A	
		S2000014	Rubber Conductor	
		S2000015	LCD Support	
		S6000047	Optical filter	
		R3073960	LCD cover	
		R7073970B	LCD filter	
		R0073880A	Lamp cover	
			<b>LAMP</b>	
	PL3001	Q1000048	BQ034-3065A	14V 40mA
<b>SWITCH UNIT</b>				
	<b>Symbol No.</b>	<b>Part No.</b>	<b>Description</b>	
	PB-2315C	F0002315C	Printed Circuit Board	
		C0023150	P.C.B. with components	











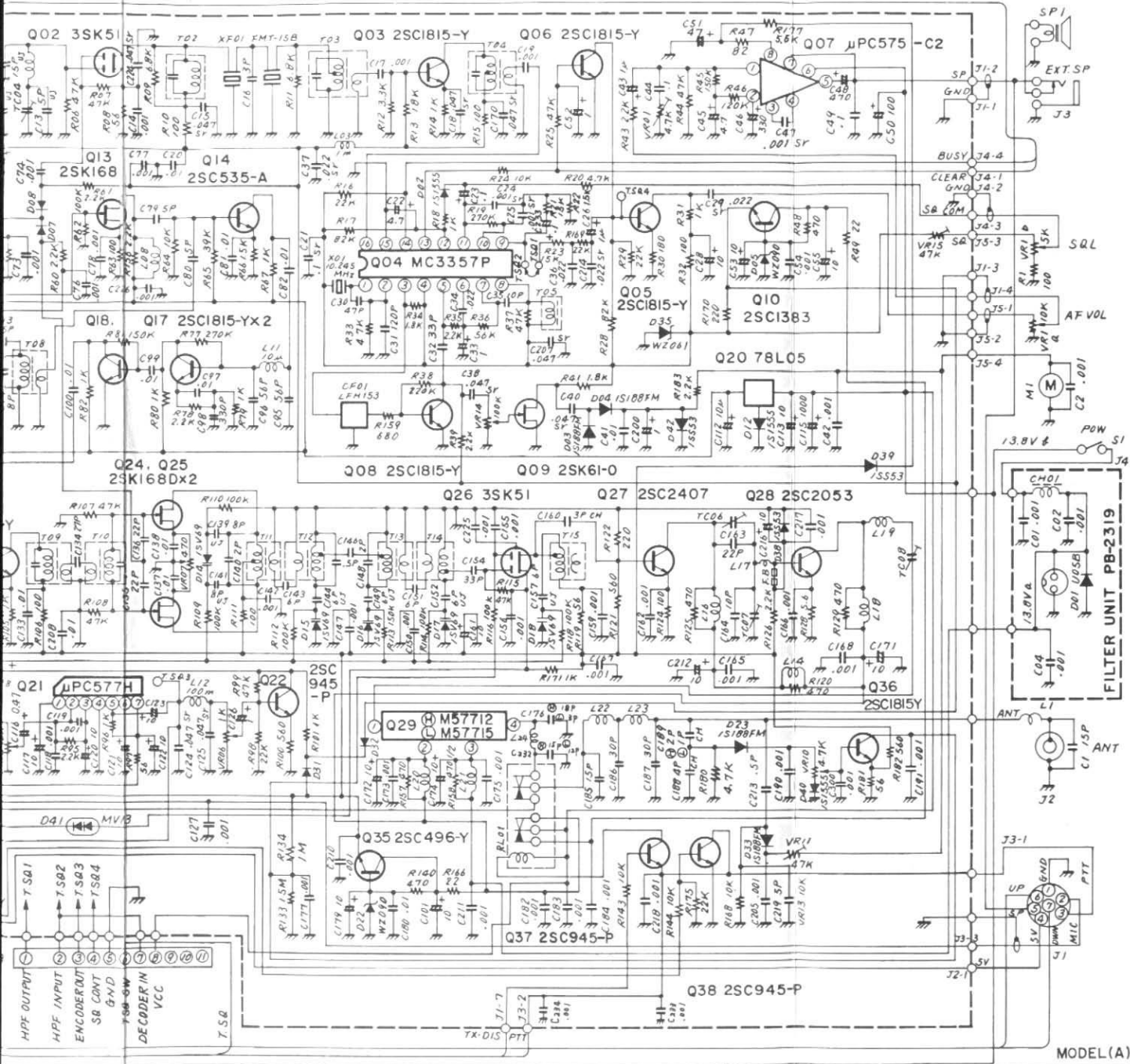

ARE 1SS53 UNLESS OTHERWISE NOTED.

MINIAL.

230R(H) 25W TYPE. (D) MARK FT-230R 10W TYPE.

MODEL (A)

FT-230R  
CIRCUIT DIAGRAM

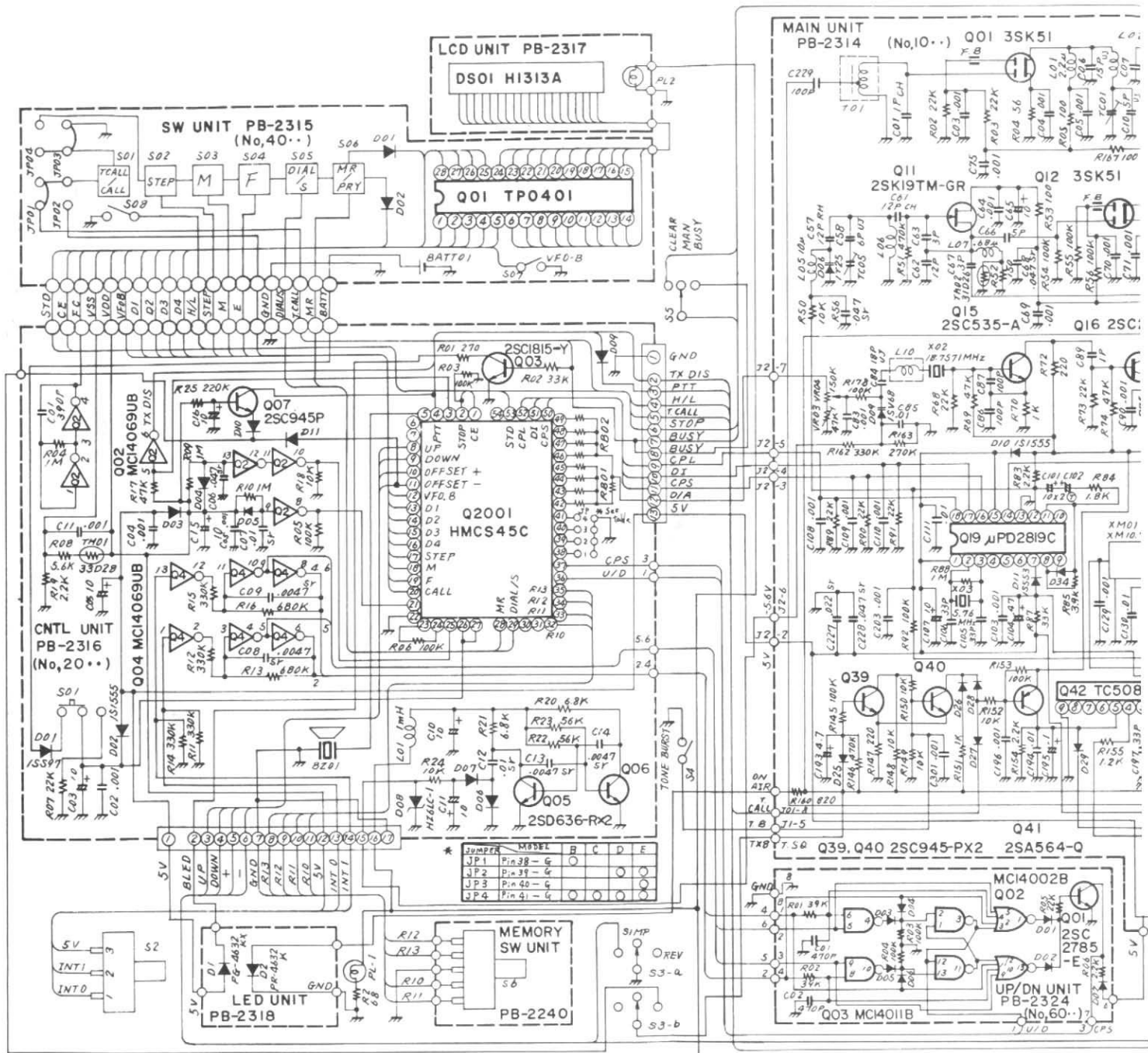

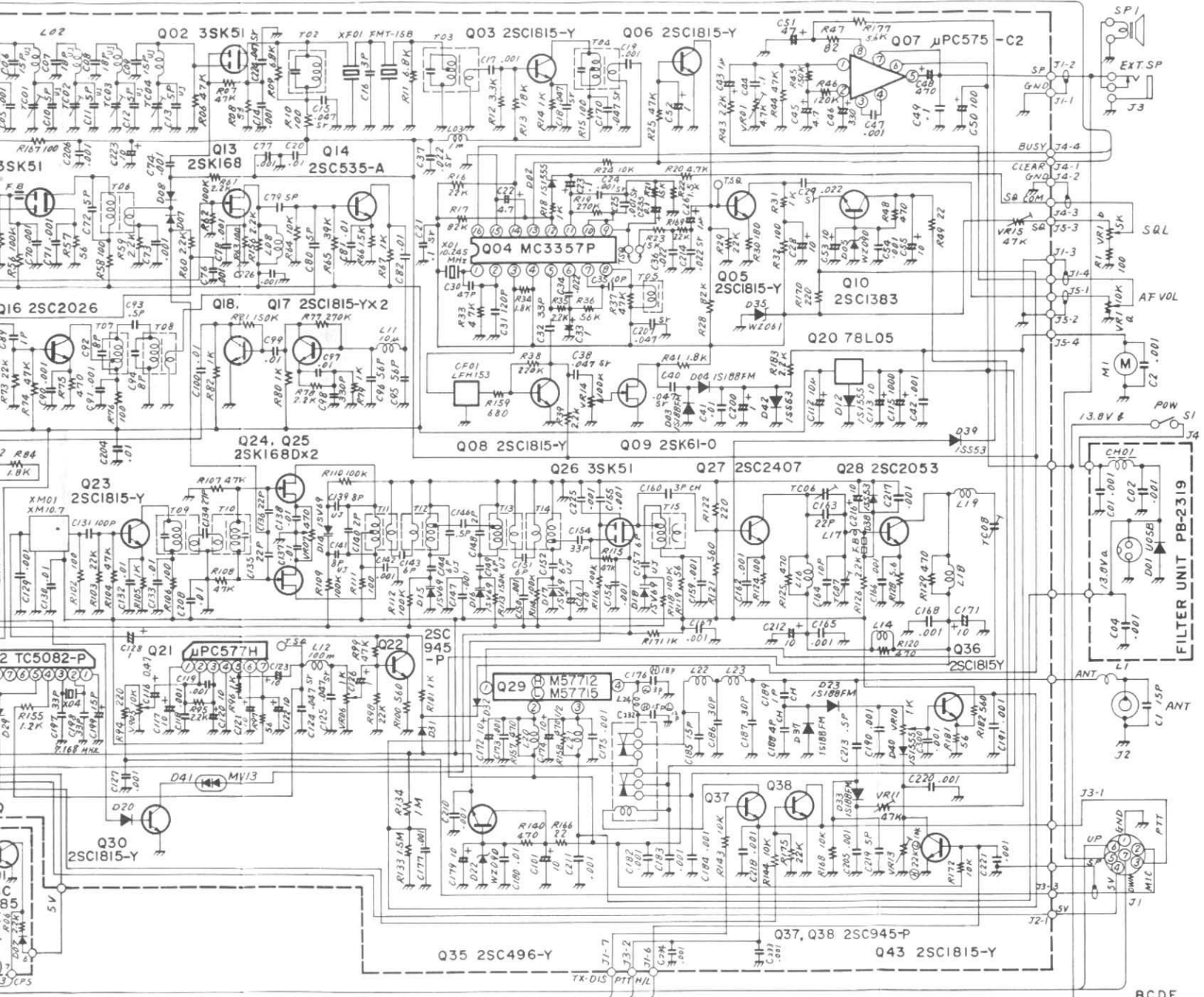

3. ALL DIODES ARE 1SS53 UNLESS OTHERWISE NOTED.  
 4. VALUE IS NOMINAL.  
 5. (⊕) MARK FT-230R(H) 25W TYPE. (⊙) MARK FT-230R 10W TYPE.

FT-230R  
 CIRCUIT DIAGRAM

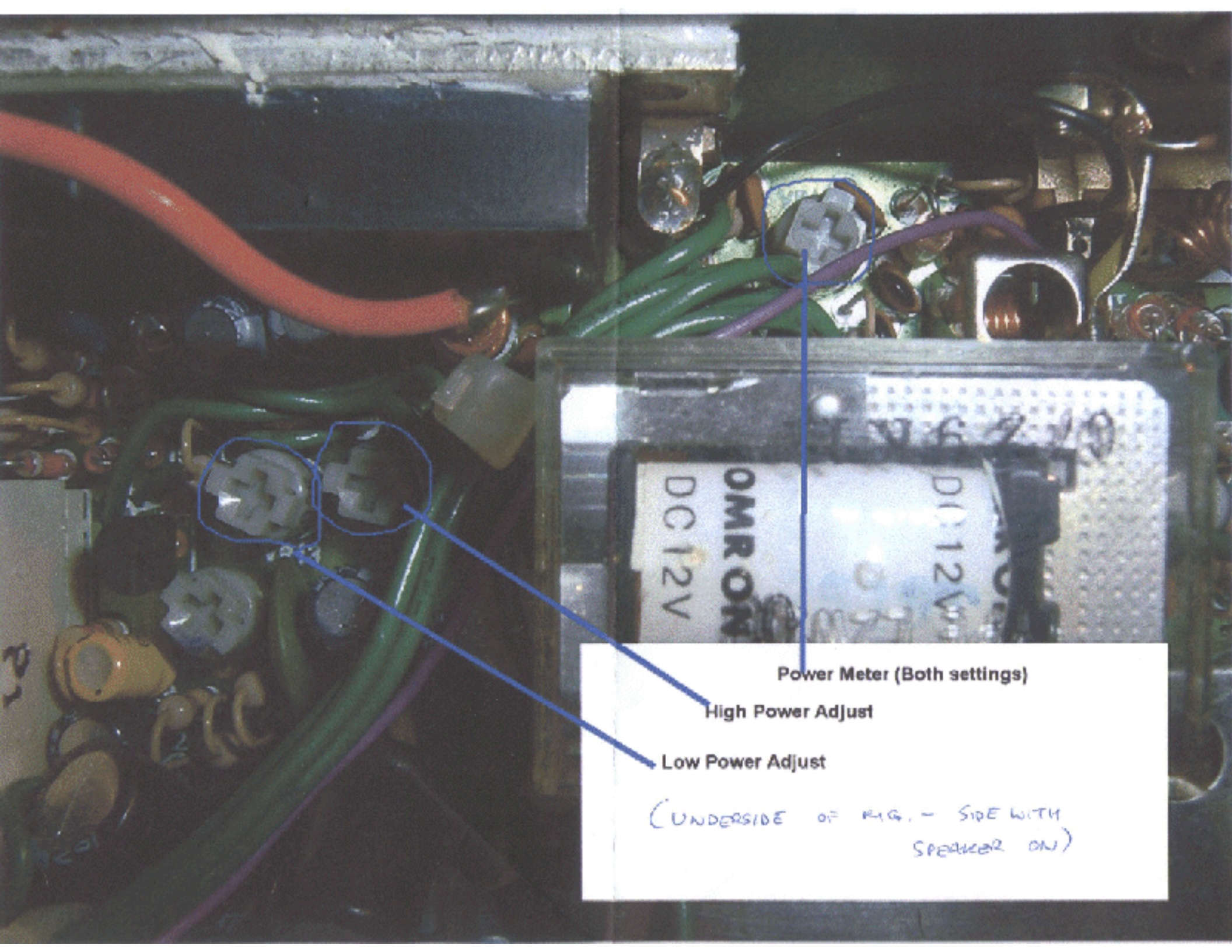

Power Meter (Both settings)

High Power Adjust

Low Power Adjust

(UNDERSIDE OF RIG. - SIDE WITH  
SPEAKER ON)