

YAESU

Radio for Professionals

C4FM/FM 144/430MHz
DUAL BAND DIGITAL TRANSCEIVER

FTM-310DR

FTM-310DE

Advance Manual

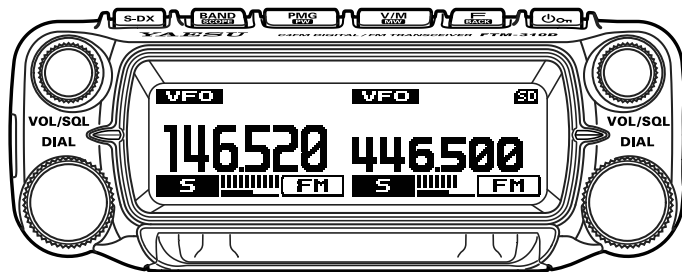

Contents

Digital Group ID (DG-ID) feature	1
About the Digital Group ID (DG-ID) feature	1
Communicating with the DG-ID feature	1
Setting the transmit and receive DG-ID number to "00" to communicate with all other stations using C4FM digital mode	1
Communicate only with the specific members by setting the DG-ID number except for "00"	2
Digital Personal ID (DP-ID) feature	3
About the Digital Personal ID (DP-ID) feature	3
Registering the DP-ID to a DR-2X digital repeater	3
DR-2X Remote Control Feature	3
Registering the DP-ID of other stations	4
Deleting a registered DP-ID	5
Communicating with specified stations in the Analog FM mode .	6
Selecting the squelch type in the analog FM mode	6
Tone squelch feature	7
Setting CTCSS Tone frequency	7
Searching for the CTCSS Tone transmitted by the other Station	7
Digital Code Squelch (DCS) feature	8
Setting the DCS CODE	8
Searching for the DCS Code Used by the Other Station	8
New Two-Tone CTCSS Pager Function	9
Using the Pager Function	9
Setting the Code for this Station	9
Receiving "Pager Code" calls from a Remote Station (Standby Operation) ...	10
Notification of a Call from a Remote Station by the Bell Function	10
Convenient memory function	11
Programmable Memory Channel Scan (PMS)	11
Registering to the Programmable Memory Channels	11
Performing Programmable Memory Channel Scan	11
DTMF Operation	12
Registering the DTMF memory	12
Setting the auto dialer function	12
Transmitting DTMF code automatically using DTMF memory	12
Manually Transmitting the DTMF Code	12
Using the GPS Function	13
Positioning Using GPS	13
GPS Screen Information and Operation	14
Saving GPS Information (GPS Log Function)	15
Checking Tracks on Your PC	15
Copying the Radio Data to another Transceiver	16
Connecting an external device	17

Connecting to a computer	17
Transmitting GPS location information	18
Using the transceiver for packet communications	19
Updating the transceiver firmware	21
Setup Menu	22
Setup Menu Operation	22
Tables of Setup Menu Operations	23
Setup Menu Operations	31
DISPLAY	31
1 KEY PAD	31
2 LCD DIMMER.....	31
3 LCD CONTRAST	31
4 BAND SCOPE.....	31
5 S-METER SYMBOL.....	31
6 BACKLIGHT COLOR.....	32
7 COMPASS.....	32
8 GPS INFORMATION.....	32
TX	33
9 TX POWER	33
10 AMS TX MODE	33
11 MIC GAIN	33
12 VOX.....	33
13 AUTO DIALER.....	33
14 TOT.....	34
15 DIGITAL VW	34
RX	35
16 FM BANDWIDTH	35
17 RX MODE.....	35
18 SUB BAND	35
19 AUDIO EQUALIZER.....	36
MEMORY	37
20 HOME CH.....	37
21 MEMORY LIST.....	37
22 MEMORY LIST MODE.....	37
23 PMG.....	37
CONFIG	38
24 BEEP	38
25 BAND SKIP	38
26 RPT ARS	38
27 RPT SHIFT	38
28 RPT SHIFT FREQ.....	38
29 RPT REVERSE	39
30 MIC PROGRAM KEY.....	39
31 DATE&TIME ADJUST.....	39
32 DATE&TIME FORMAT.....	39
33 TIME ZONE.....	39
34 STEP	40

35	CLOCK TYPE	40
36	UNIT	40
37	APO	40
38	GPS DATUM	40
39	GPS LOG	41
AUDIO		42
40	RECORDING	42
41	REC/STOP	42
42	REAR SP OUT	42
43	FRONT SP MUTE	42
SIGNALING		43
44	DTMF	43
45	DTMF MEMORY	43
46	SQL TYPE	43
47	TONE SQL FREQ / DCS CODE	43
48	SQL EXPANSION	43
49	PAGER CODE	43
50	PR FREQUENCY	44
51	BELL RINGER	44
52	WX ALERT	44
SCAN		45
53	SCAN	45
54	DUAL RECEIVE MODE	45
55	DUAL RX INTERVAL	45
56	PRIORITY REVERT	45
57	SCAN RESUME	45
DIGITAL		46
58	DIGITAL POPUP	46
59	LOCATION SERVICE	46
60	STANDBY BEEP	46
GM		47
WIRES-X		47
DATA		48
70	COM PORT	48
71	DATA BAND	49
72	DATA SPEED	50
73	DATA SQL	51
APRS		52
SD CARD		53
108	BACKUP	53
	Save the transceiver settings information	53
	Load the transceiver settings information	53
109	SD INFORMATION	54
110	SD FORMAT	54
OPTION		55
111	Bluetooth	55
112	VOICE MEMORY	55
113	FVS REC	55

114 TRACK SELECT.....	55
115 FVS PLAY.....	55
116 FVS STOP.....	55
117 FVS CLEAR.....	55
118 VOICE GUIDE.....	55
CLONE/RESET	56
119 This → Other.....	56
120 Other → This.....	56
121 CALLSIGN.....	56
122 MEMORY CH RESET.....	56
123 APRS RESET.....	56
124 CONFIG SET.....	57
125 CONFIG RECALL.....	57
126 SOFTWARE VERSION.....	57
127 FACTORY RESET.....	57
Appendix	58
The folder configuration of the micro-SD card	58
Using the optional Swing Head Kit “SJKM-500”	59
Remove the control head from the transceiver body	59
Attach the SJKM-500 to the control head	59
Maintenance	60
Care and maintenance	60
Replacing the fuse	60
Troubleshooting	61
There is no power	61
There is no sound	61
There is no transmission	61
The keys or knobs do not operate	61

Digital Group ID (DG-ID) feature

About the Digital Group ID (DG-ID) feature

Digital Group ID (DG-ID) function allows using the two-digit ID numbers to communicate only with specific group members. The desired DG-ID number from 00 to 99 is set in advance by all the group members. This ID number may be set separately for transmit and receive, when the same ID number is set for both transmit and receive, only group members with the same ID number will be heard. This feature may be used to limit communication only to group members that have the same DG-ID number. The GM function may also be utilized to automatically monitor whether or not group member stations with the same DG-ID number are operating within communication range.

The DG-ID number 00 detects signals with all ID numbers. Normally setting the ID number to "00" for both transmit and receive will permit reception of the signals from all other stations using the digital C4FM mode, regardless of the transmit DG-ID number settings of the other stations.

Also note that when the receive DG-ID number of the transceiver is set to a DG-ID number other than "00", received signals that do not have the same DG-ID number may not be heard.

When accessing a C4FM digital repeater controlled by a DG-ID number, set the transmit DG-ID number of the FTM-310DR/DE to that of the repeater input. Even in that case, if the receive DG-ID number of the FTM-310DR/DE is set to "00", all the downlink signals from the repeater may be received.

Communicating with the DG-ID feature



Digital C4FM mode transceivers compatible with the DG-ID function are required in order to utilize this function.

Setting the transmit and receive DG-ID number to "00" to communicate with all other stations using C4FM digital mode

1. Press the key.
2. Rotate the Right **DIAL** knob to select **[GM]** → press and hold the Right **DIAL** knob. The DG-ID number setting screen will be displayed.
3. If the transmit DG-ID (DG-ID TX) number is not set to "00", press the Right **DIAL** knob, and then rotate the Right **DIAL** knob to set "00".



While setting the DG-ID number, pressing and holding the Right **DIAL** knob will set the transmit and the receive DG-ID numbers to "00".





4. Press the key, and rotate the Right **DIAL** knob to select the receive DG-ID (DG-ID RX).
5. If the receive DG-ID number is not set "00", press the Right **DIAL** knob, then rotate the Right **DIAL** knob to set "00".
6. Press any key or **DIAL** knob, other than the or key, to save the settings and return to normal operation.



- If the receive DG-ID is set to a number other than "00", only signals with that DG-ID will be received. Normally, set the receive DG-ID number to "00" except when communication is desired only with group members.
- The transmit and receive DG-ID default number is set to "00".

Communicate only with the specific members by setting the DG-ID number except for “00”

Example: Set the DG-ID number of to “50”

1. Press the  key.
2. Rotate the Right **DIAL** knob to select **[GM]** → press and hold the Right **DIAL** knob. The DG-ID number setting screen will be displayed.
3. Press the Right **DIAL** knob, and then rotate the Right **DIAL** knob to set “50”.
4. Press the  key, and rotate the Right **DIAL** knob to select the receive DG-ID (DG-ID RX).
5. Press the Right **DIAL** knob, then rotate the Right **DIAL** knob to set “50”.
6. Press any key or **DIAL** knob, other than the  or  key, to save the settings and return to normal operation.

Tuning to the same frequency and setting the same DGID for all the group members will enable communication between the members and exclude other signals.

Digital Personal ID (DP-ID) feature

About the Digital Personal ID (DP-ID) feature

When operating in digital C4FM communications, each transceiver is programmed with, and sends its own individual ID information (Radio ID) in each transmission. The DP-ID function and the individual identification information, makes possible group communications between stations that are within communications range. The Digital Personal ID (DP-ID) feature opens the speaker audio only when a signal set to the same DP-ID in the Digital Mode is received, even if each transceiver is set to a different Digital Group ID (DG-ID) number.



To utilize this function, Digital C4FM mode transceivers compatible with the DG-ID function are required.

Registering the DP-ID to a DR-2X digital repeater

After registering the transceiver's DP-ID to the DR-2X repeater, the settings and functions of the DR-2X can be remotely controlled. Remote control cannot be performed from a transceiver that has not been registered with the DP-ID, so it is possible to securely manage repeaters. The transceiver with DP-ID registered in DR-2X is allowed preferential access in an emergency, even when used without the DG-ID setting.



To register the transceiver DP-ID in the DR-2X C4FM digital repeater, refer to the DR-2X instruction manual.

DR-2X Remote Control Feature

To display the FTM-310D remote-control screen while in C4FM digital mode, press and hold the [*] key on the microphone. To return to normal mode, press the [*] key on the microphone. For details on the remote-control function of the DR-2X, refer to the DR-2X instruction manual.

- Activate the repeater operation
- Deactivate the repeater operation
- Set the repeater to C4FM mode
- Set the transmit power
- Voice Message Control (Rec / Play / Stop)
- Set the Emergency Call

Registering the DP-ID of other stations



- Once registered, the DP-ID is stored until deleted.
 - Register each other's DP-ID with nearby transceivers.
 - When setting the DG-ID code to "00", the transceiver will receive signals from all digital C4FM stations. To utilize the DP-ID function, it is necessary to set the receive DG-ID code to a number other than "00".
-

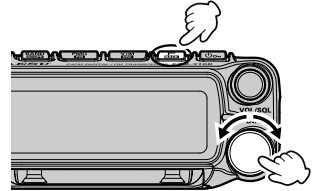

1. Press and hold the  key.
2. Rotate the Right **DIAL** knob to select [61 DP-ID LIST].
3. Press the Right **DIAL** knob.
 - The DP-ID list is displayed.
 - If several DP-IDs are displayed, rotate the Right **DIAL** knob to register the desired DP-ID.



4. A transmission in the digital C4FM mode from another transceiver will register the DP-ID.
When a signal from the other station is received, the call sign and "Registration" are displayed on the LCD.
-



- When a signal from another registered transceiver is received, nothing is displayed on the LCD.
 - When a transceiver is previously registered with a different call sign, the DP-ID listing is changed to the newly registered call sign.
-

5. Press the Right **DIAL** knob to save the setting.
 - When registering the DP-ID is complete, the display returns to the DP-ID list screen.
 - If not registering a DP-ID, rotate the Right **DIAL** knob to select "**CANCEL**" then press the Right **DIAL** knob.
 - If registering several DP-IDs, repeat step 4.
 6. Press any key or **DIAL** knob, other than the  or  key, to save the settings and return to normal operation.
 - All the other communicating stations should similarly register the DP-IDs to the DP-ID lists of their transceivers.
 - The DP-ID setting is complete.
-



To communicate using the DP-ID function, register the DP-ID of each other's transceiver on both transceivers. By registering the DP-ID, users may communicate even if the Digital group ID (DG-ID) is a different setting.

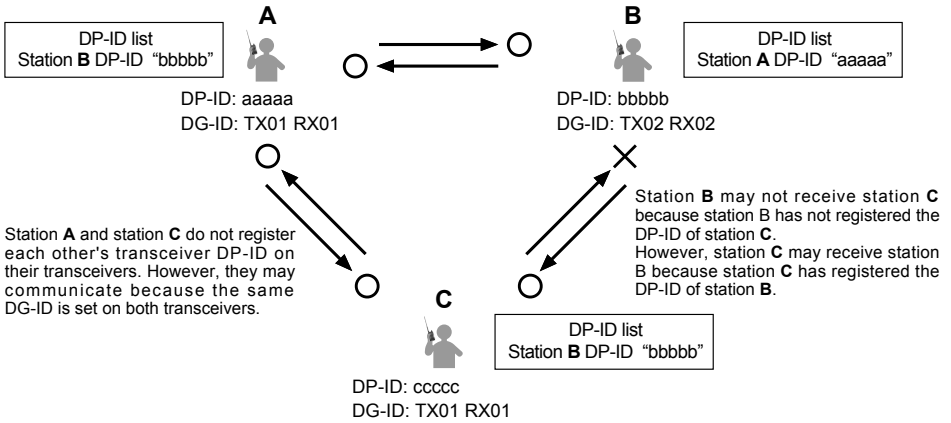

The transceivers may communicate even if the Digital Group ID (DG-ID) is a different setting because Station A and station B have registered each other's DP-IDs on both transceivers.



Deleting a registered DP-ID

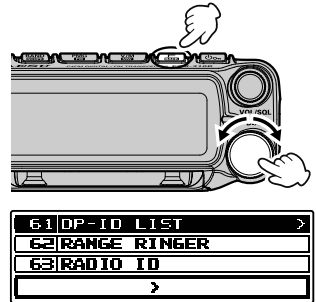

1. Press and hold the  key.
2. Rotate the Right **DIAL** knob to select [61 DP-ID LIST].
3. Press the Right **DIAL** knob.
The DP-ID list is displayed.



4. Rotate the Right **DIAL** knob to select the call sign of the other transceiver, then press the Left **DIAL** knob.
5. Press the Right **DIAL** knob.
Confirmation screen "DELETE?" is displayed.
6. Rotate the Right **DIAL** knob to select [OK] then press the Right **DIAL** knob to delete.
 - If not deleting in the DP-ID list, select [CANCEL] then press the Right **DIAL** knob.
 - If deleting several DP-IDs, press the  key, then repeat step 4 to 6.
7. Press any key or **DIAL** knob, other than the  or  key, to save the settings and return to normal operation.

Communicating with specified stations in the Analog FM mode

Selecting the squelch type in the analog FM mode

1. Press and hold the  key.
2. Rotate the Right **DIAL** knob to select **[46 SQL TYPE]**.
3. Press the Right **DIAL** knob.
4. Rotate the Right **DIAL** knob to select the type of squelch, refer to the table below.
5. Press any key or **DIAL** knob, other than the  or  key, to save the settings and return to normal operation.

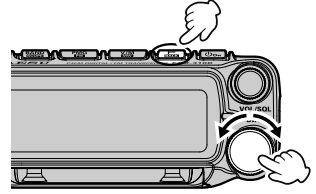

46 SQL TYPE
47 TONE SQL FREQ
48 SQL EXPANSION
OFF



Tone squelch (CTCSS), DCS and the New PAGER (EPCS) functions do not operate in the C4FM digital mode. Press and hold the **VOL/SQL** knob to change to the Analog FM mode, or turn the AMS function ON.

Squelch type	Description
OFF	Deactivates the CTCSS and DCS functions. Returns to the normal squelch operation in the Analog FM mode.
STONE ENC	Activates the CTCSS tone for Analog FM Transmissions. Receives with normal squelch operation.
STONE SQL	Activates the CTCSS tone squelch function on Analog FM receive.
REV TONE	Activates the reverse tone function. Used to monitor communications based on the squelch control system. When a signal contains the designated tone, the squelch is not opened, and when the tone signal disappears, the squelch opens, and communication starts.
DCS	Activates the Digital Code Squelch (DCS) function. The DCS code may be selected from 104 codes (from 023 to 754).
PR FREQ	Activates the no-communication squelch function for radios. The no-communication signal tone frequencies may be specified within the range of 300 Hz to 3000 Hz in steps of 100 Hz.
PAGER	Activates a new two-tone CTCSS pager function. When communicating with transceivers among friends, specify personal codes (each code is composed of two tones) so that only specific stations are called.
DCS ENC*	Transmits the signal containing the DCS CODE. Receives as a normal squelch operation.
TONE DCS*	Sends a tone signal when transmitting, and receives only signals with a matching DCS code.
DCS TSQL*	Sends a DCS CODE when transmitting and receives only signals that contain a matching tone signal when receiving.

* Press and hold the  key → **[48 SQL EXPANSION]** → Press the **FUNC** knob to access "ON", "DCS ENC", "TONE DCS" and "DCS TSQL" setting values are activated.

-
- The squelch type may be set for each frequency band (BAND).
 - The CTCSS and DCS squelch settings are also active during scanning. If scanning is performed with the CTCSS and DCS squelch function activated, scanning stops only when a signal containing the specified CTCSS tone or DCS code is received.
 - Pressing the program key on the microphone to which the "SQL OFF" function is assigned, allows all signals that do not contain a tone or DCS code, and signals with different tones, DCS codes, digital mode signals to all be heard.
-



Tone squelch feature

The tone squelch opens the speaker audio only when a signal containing the specified CTCSS tone is received. The receiver will be quiet while waiting for a call from a specific station.



The Tone Squelch does not function in digital mode. Press and hold the **VOL/SQL** knob to change from Digital, to Analog FM or to AMS function.

Setting CTCSS Tone frequency

The tone may be selected from 50 frequencies (67.0 Hz to 254.1 Hz).

1. Press and hold the key.
2. Rotate the Right **DIAL** knob to select [**46 SQL TYPE**] then press the Right **DIAL** knob.
3. Rotate the Right **DIAL** knob to select [**TONE SQL**] then press the key.
4. Rotate the Right **DIAL** knob to select [**47 TONE SQL FREQ**] then press the Right **DIAL** knob.
5. Rotate the Right **DIAL** knob to select the tone frequency.
6. Press any key or **DIAL** knob, other than the or key, to save the settings and return to normal operation.



- The tone frequency setting is common with the squelch types as follows: "TONE ENC", "TONE SQL", "REV TONE", "TONE DCS", "DCS TSQL".
- The default setting is "100.0 Hz"

Searching for the CTCSS Tone transmitted by the other Station

Search and display the CTCSS tone transmitted by the other station.



- Tone search does not function in digital mode. Press and hold the **VOL/SQL** knob to change from Digital to Analog FM or the AMS function.
- To set the transceiver operation when scanning stops, press and hold the key → [**57 SCAN RESUME**] → press the Right **DIAL** knob. This setting is common with the scan setting, tone search function and DCS search function.

1. Press and hold the key.
2. Rotate the Right **DIAL** knob to select [**46 SQL TYPE**] then press the Right **DIAL** knob.
3. Rotate the Right **DIAL** knob to select [**TONE SQL**] then press the key.
4. Rotate the Right **DIAL** knob to select [**47 TONE SQL FREQ**].
5. Press the Right **DIAL** knob.
6. Press and hold the microphone [**UP**] or [**DWN**] switch.
 - The transceiver begins searching for a matching tone frequency.
 - When a corresponding tone frequency is detected, the searching stops and the audio is heard.
 - Press the **PTT** switch or the [**UP**] or [**DWN**] switch to stop searching.
7. Press the **PTT** to save the detected tone frequency and return to normal operation.





Digital Code Squelch (DCS) feature

The Digital Code Squelch opens the speaker audio only when a signal containing the specified DCS code is received. The DCS code may be selected from 104 types (from 023 to 754).



The DCS Squelch does not function in digital mode. Press and hold the **VOL/SQL** knob to change from Digital to Analog FM or AMS mode.

Setting the DCS CODE

1. Press and hold the  key.
 2. Rotate the Right **DIAL** knob to select [**46 SQL TYPE**] then press the Right **DIAL** knob.
 3. Rotate the Right **DIAL** knob to select [**DCS**] then press the  key.
 4. Rotate the Right **DIAL** knob to select [**47 DCS CODE**] then press the Right **DIAL** knob.
 5. Rotate the Right **DIAL** knob to select the DCS code.
 6. Press any key or **DIAL** knob, other than the  or  key, to save the settings and return to normal operation.
-





- The DCS code set in the above operation is common for all transmissions with a DCS Code (“DCS”, “DCS ENC”, “TONE DCS”, “DCS TSQ L”).
 - The default DCS code is “023”.
-

Searching for the DCS Code Used by the Other Station

Search for the DCS code used by the other station.



- The DCS search does not function in digital mode. Press and hold the **VOL/SQL** knob to change from Digital to Analog FM or AMS mode.
 - To set the transceiver operation when scanning stops, press and hold the  key → [**57 SCAN RESUME**] → press the Right **DIAL** knob. This setting is common with the scan setting, tone search function and DCS search function.
-

1. Press and hold the  key.
2. Rotate the Right **DIAL** knob to select [**46 SQL TYPE**] then press the Right **DIAL** knob.
3. Rotate the Right **DIAL** knob to select [**DCS**] then press the  key.
4. Rotate the Right **DIAL** knob to select [**47 DCS CODE**] then press the Right **DIAL** knob.
5. Press and hold the Microphone [**UP**] or [**DWN**] switch.
 - The transceiver begins searching for a matching DCS code.
 - When a corresponding DCS code is detected, the searching stops and the audio is heard.
 - Press the **PTT** switch or the [**UP**] or [**DWN**] switch to stop searching.
6. Press the **PTT** switch to save the detected DCS code and return to normal operation.





New Two-Tone CTCSS Pager Function

When using **FTM-310DR/DE** transceivers with a group of friends, setting the Two-Tone CTCSS personal codes allows calling just the specific stations. Even when the person who is called is not near the transceiver, the information on the LCD indicates that a call was received.





The new two-tone CTCSS pager feature does not operate in digital mode. Press and hold the **VOL/SQL** knob to change from Digital to Analog FM or the AMS function.

Using the Pager Function

1. Press and hold the  key.
2. Rotate the Right **DIAL** knob to select **[46 SQL TYPE]** then press the Right **DIAL** knob.
3. Rotate the Right **DIAL** knob to select **[PAGER]** then press the  key.
4. Press any key or **DIAL** knob, other than the  or  key, to save the settings and return to normal operation.



Setting the Code for this Station

Set the “pager code” to be called by other stations.

1. Press and hold the  key.
2. Rotate the Right **DIAL** knob to select **[49 PAGER CODE]** then press the Right **DIAL** knob.
3. Rotate the Right **DIAL** knob to select **[RX CODE 1]** then press the Right **DIAL** knob.
4. Rotate the Right **DIAL** knob to select the RX CODE 1 of the code from 01 to 50.
5. Press the  key.
6. Rotate the Right **DIAL** knob to select **[RX CODE 2]** then press the Right **DIAL** knob.
7. Rotate the Right **DIAL** knob to select the RX CODE 2 of the code from 01 to 50.

The same code cannot be used for RX CODE 1 and RX CODE 2.

Next, set the pager code for directing a call to a specific partner station.

8. Rotate the Right **DIAL** knob to select **[TX CODE 1]** then press the Right **DIAL** knob.
 9. Rotate the Right **DIAL** knob to select the TX CODE 1 of the codes from 01 to 50.
 10. Press the  key.
 11. Rotate the Right **DIAL** knob to select **[TX CODE 2]** then press the Right **DIAL** knob.
 12. Rotate the Right **DIAL** knob to select the TX CODE 2 of the codes from 01 to 50.
- The same code cannot be used for TX CODE 1 and TX CODE 2.
13. Press any key or **DIAL** knob, other than the  or  key, to save the settings and return to normal operation.
 14. Press the **PTT** switch to transmit a call to the specific station.



- The reverse combination works as the same code, that is “05 47” is the same as “47 05”.
 - If the same code is specified for all individuals, all the individuals can be called at the same time.
 - The default code is “05 47”.
 - When receiving the codes, the sound of the tones may be heard intermittently.
-

Receiving “Pager Code” calls from a Remote Station (Standby Operation)

When the Pager function is activated, the audio of received calls with a corresponding Pager Code is heard.

Furthermore, when the Bell function (see below) is activated, the bell rings when receiving calls from the other station.

Notification of a Call from a Remote Station by the Bell Function

The Bell may be set to sound an Alert when a call from another station containing a corresponding tone, DCS or pager code is received.

1. Press and hold the Right **DIAL** knob.
2. Rotate the right **DIAL** knob to select [51 BELL RINGER].
3. Press the Right **DIAL** knob.
4. Rotate the Right **DIAL** knob to select the desired number of times (1 - 8 times or continuous) the Bell rings.



OFF / 1 time / 3 times / 5 times / 8 times / CONTINUOUS

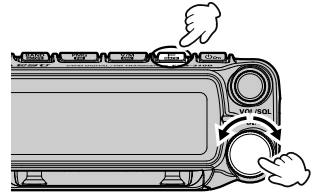

If the setting is “CONTINUOUS”, the bell keeps sounding until an operation is made.



49 PAGER CODE	➤
50 PR FREQUENCY	
51 BELL RINGER	
OFF	

5. Press any key or **DIAL** knob, other than the  or  key, to save the settings and return to normal operation, the "📶" icon appears on the display.

Convenient memory function

Programmable Memory Channel Scan (PMS)

Registering to the Programmable Memory Channels

50 sets of PMS memory channels (L01/U01 to L50/U50) are available.

- Register the lower and upper frequencies of the frequency range in a pair of Programmable Memory Channels.

L nn: Lower limit memory channel

U nn: Upper limit memory channel

- On the Memory Channel List screen, press the **[A]** key on the microphone to jump the “L01” PMS Memory Channel.



- Make sure to use the corresponding numbers for the lower and upper limit memory channels.
- Set the Programmable Memory scanning (PMS) lower and upper limits as follows:
 - The lower and upper limit memory channels must be within the same frequency band.
 - The lower and upper limit memory channels must not be registered in reverse.

Performing Programmable Memory Channel Scan

The programmable memory channel scan allows scanning a specified frequency range within the same frequency band.

1. Press the  key to enter the memory mode.
2. Recall the PMS memory channel to which the lower limit (Lnn) or upper limit (Unn) of the frequency band is registered.
3. Press and hold the **[UP]** or **[DWN]** switch of the microphone.
 - Programmable memory channel scanning starts.
 - Pressing the program key on the microphone set to the “SCAN” function also starts the PMS scan operation.
 - If the **DIAL** knob is rotated while scanning is in progress, the scanning will continue up or down in frequency according to the direction of the **DIAL** knob rotation.If the scanner halts on an incoming signal, the frequency will blink. Scanning will resume in about 3 seconds.
4. Press the **PTT** switch or the **[UP]** or **[DWN]** switch on the microphone, to cancel the scanning.

In this state (displayed as “PMS” at the upper left of the display), the frequency can be changed only in the range stored by the lower and upper PMS memories, by rotating the **DIAL** knob.



● Disable the PMS function

1. Press the  key.
Returns to the normal memory mode.

DTMF Operation



DTMF (Dual Tone Multi Frequencies) are the tone signals sent to make telephone calls, or control repeaters and network links. Up to 9 registers of 16-digit DTMF tone codes can be stored as telephone numbers to make calls through the public telephone network using a phone patch or to connect through the WIRELESS analog node station.

Registering the DTMF memory

1. Press and hold the  key → [45 DTMF MEMORY] → Press the Right **DIAL** knob.
2. Rotate the Right **DIAL** knob to select the desired channel (1 to 9) to register the DTMF code, then press the Right **DIAL** knob.
The DTMF memory channel input screen is displayed.
3. Use the Right **DIAL** knob or the numeric keypad of the microphone to input the DTMF code up to a maximum of 16 digits.
4. Press and hold the Right **DIAL** knob to save the DTMF code.
5. Press any key or **DIAL** knob, other than the  or  key, to save the settings and return to normal operation.

Setting the auto dialer function

Use the auto dialer function to automatically transmit the DTMF code registered in the DTMF memory.

1. Press and hold the  key → [13 AUTO DIALER] → Press the Right **DIAL** knob.
2. Rotate the Right **DIAL** knob to select “ON”.
3. Press any key or **DIAL** knob, other than the  or  key, to save the settings and return to normal operation.

When set to “ON”, the DTMF icon “” will be shown on the display.

Transmitting DTMF code automatically using DTMF memory

1. Set the “ON” by referring to “Transmitting the Registered DTMF Code” (above).
2. Press and hold the  key → [44 DTMF] → Press the Right **DIAL** knob.
3. Rotate the Right **DIAL** knob to select the desired DTMF memory (1 to 9).
4. Press the **PTT** switch.
 - The DTMF code registered in the DTMF memory channel is automatically transmitted.
 - Even after releasing the **PTT** switch, the transmission continues until the DTMF code is completed. The transceiver is automatically returned to receive mode.
 - To send DTMF memory, press the number key of that number on the microphone during transmission.

Manually Transmitting the DTMF Code

1. While pressing and holding the **PTT** switch, use the numeric keypad of the microphone and press each digit of the DTMF code in sequence to transmit the code.



The DTMF code can be sent manually regardless of whether the auto dialer is set to ON or OFF.

Using the GPS Function

The transceiver is equipped with an internal GPS receiver to acquire and display the position information. The GPS information can be used as described in the following examples:

Save this station location information and display the route on a computer

→ Refer to “Saving GPS Information (GPS Log Function)” (Page 15)

Save the DP-ID of frequently contacted stations and check whether they are within the sphere of communications

→ Refer to the separate “Operating Manual GM Edition”

Exchange position information and messages through data communications with other stations

→ Refer to the separate “Operating Manual APRS Edition”

Positioning Using GPS

The built-in GPS receiver function is enabled when the power of the **FTM-310DR/DE** is turned ON. The satellite search will begin and the “” icon will be shown at the top of the display. The **FTM-310DR/DE** automatically obtains the internal clock setting, and the location information setting from the GPS data.



- It may take several minutes to acquire the GPS satellites.
- When three or more satellites cannot be acquired, the “” icon will disappear. In this case, positioning is not possible, and the position information cannot be used.

About Positioning by GPS

“Positioning” refers to calculation of the current position from the satellite orbit information and radio propagation time. At least 3 satellites must be acquired for successful positioning. If positioning fails, move away from buildings as far as possible away buildings and position the GPS receiver in an area with open sky.

● **About errors**

The measurement environment may result in positioning errors of several hundred meters. Under favorable conditions, positioning can be performed successfully using only three satellites. However, under the following poor conditions, the positioning accuracy can decrease, or positioning can fail:

- Between tall buildings
- Narrow paths between buildings
- Indoors or near large buildings
- Between trees such as in forests or woods
- Under elevated roads or high voltage power lines
- Inside a tunnel or underground
- Through heat reflective glass
- Areas with strong magnetic fields

● **When not in use for a long time**

When using the GPS functions for the first time after purchase, or when it has been unused in a while, a few minutes may be required to acquire the satellites. Also, if the GPS function has been turned OFF for several hours, a few minutes may be required to search for satellites.

GPS Screen Information and Operation

Displays the status of signals received from GPS satellites and related information.

1. Press and hold the **FUNC** knob → [8 GPS INFORMATION] → Press the Right **DIAL** knob.

① Azimuth and elevation of satellite

② Time

③ Latitude and longitude of the current location

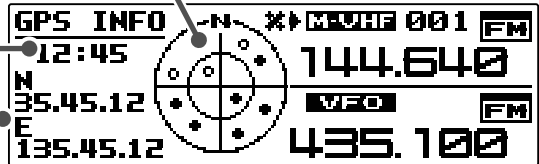

- ① Displays the satellite azimuth and elevation angles. Displays in North-up mode.
- ② Current time (24-hour display)
- ③ Displays the latitude and longitude

Latitude (upper side)

Display format: X DD.MM.MM

X: X=N: North latitude, X=S: South latitude

DD: Degree

MM.MM: Minute

Example: N 35.45.12 (35 degrees, 45 minutes, 12 seconds north latitude)

Longitude (lower side)

Display format: X DDD.MM.MM

X: X=E: East longitude, X=W: West longitude



DDD: Degree

MM.MM: Minute

Example: E 135.45.12 (135 degrees, 45 minutes, 12 seconds east longitude)

-
- When the GPS function is used, the accurate time and date are obtained from GPS and shown on the LCD in 24-hour format. This time data is displayed on the GPS and APRS screens.







- The geodetic system datum (WGS-84 / TOKYO MEAN) of the built-in GPS unit may be changed by pressing and holding the  key → [38 GPS DATUM] in Set mode. However, since APRS uses the WGS-84 geodetic system, it is recommended not to change it.
 - The time zone may be set at 30-minute increments by pressing and holding the  key → [33 TIME ZONE] (the default setting: UTC 0:00).
-

Saving GPS Information (GPS Log Function)

The GPS position information can automatically be saved periodically onto a microSD memory card. Using the saved data, tracks can be displayed on a computer with commercially available map software*.

* Technical support for the map software is not provided by YAESU.

1. Press and hold the  key.
2. Rotate the Right **DIAL** knob to select **[39 GPS LOG]**.
3. Press the Right **DIAL** knob.
4. Rotate the Right **DIAL** knob to select the GPS data logging interval.
OFF / 1 sec / 2 sec / 5 sec / 10 sec / 30 sec / 60 sec
5. Press any key or **DIAL** knob, other than the  or  key, to save the settings and return to normal operation.

The GPS log function is activated, the “” icon changes to “”.

- The position information is saved periodically unless “OFF” is selected in step 4 (shown above) or the power of the transceiver is turned OFF.
 - Reselecting the GPS data logging interval in step 3 or turning on the transceiver again, begins saving the GPS data under a different file name.
 - To use the GPS log function, a commercially available microSD card must be inserted in the **FTM-310DR/DE**. Refer to the Operating Manual for details.
-



Checking Tracks on Your PC



1. Turn the transceiver OFF.
2. Remove the microSD memory card from the transceiver.
3. Connect the microSD memory card to a PC using a commercially available memory card reader.
4. Open the “FTM310D” folder in the microSD memory card.
5. Open the “GPSLOG” folder.
 - The data is saved as “yymmddhhmmss.log”
 - The [yymmddhhmmss] part of the name consists of year (yy), month (mm), day (dd), hour (hh), minute (mm), and second (ss).



- Tracks can be displayed on the map by importing the data to commercially available map software.
 - For information on importing, please refer to the operation manual for the map software you use.
-

Copying the Radio Data to another Transceiver

The memory channels and settings in the set-up menu can be copied to another **FTM-310DR/DE**. This is convenient when matching the settings of fellow stations that you communicate with frequently.

1. Turn both transceivers OFF.
2. Connect the clone cable “CT-166” to the DATA jack on the back of the main bodies.
3. Turn both transceivers ON.
4. On the transceiver from which data is to be copied, press and hold the  key, rotate the Right **DIAL** knob to select [**119 This → Other**], then press the Right **DIAL** knob. The confirmation screen appears.
5. On the transceiver to which data is to be copied, press and hold the  key, rotate the Right **DIAL** knob to select [**120 Other → This**], then press the Right **DIAL** knob. The confirmation screen appears.
6. On the transceiver to which data is to be copied, rotate the Right **DIAL** knob to select [**OK**], then press the Right **DIAL** knob.
7. On the transceiver from which data is to be copied, rotate the Right **DIAL** knob to select [**OK**], then press the Right **DIAL** knob. The data transfer begins.
8. Turn both transceivers OFF, then disconnect the clone cable.



- When “ERROR” appears on the screen during the clone operation, the operation has not completed. Check the clone cable connection, and then repeat the procedure from the beginning.
 - If the clone operation is terminated due to a power loss during the data transfer, the transceiver to which the data is copied will be reset automatically. Check the power supply, cables and connections, then repeat the procedure again from the beginning.
-

Connecting an external device

Using the Data cable, the transceiver can be connected to a personal computer as a COM port for the following operations:

- Transfer GPS location data and export route mapping information to computer software
- Packet communication

Use the DATA jack at the back of the main body to connect with the personal computer. The pin assignment of the DATA jack is as follows.

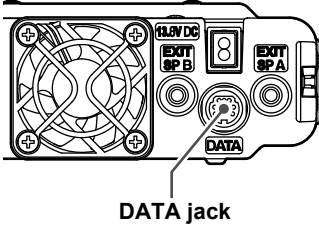

- ① PKD (packet data input)
- ② GND
- ③ PKS (PTT)
- ④ RX 9600 (9600 bps packet data output)
- ⑤ RX 1200 (1200 bps packet data output)
- ⑥ PK SQL (squellch control)
- ⑦ TXD (serial data output [transceiver → PC])
- ⑧ RXD (serial data input [transceiver ← PC])
- ⑨ CTS (data communication control)
- ⑩ RTS (data communication control)

Connecting to a computer

● Preparation

- Computer
- PC connection cable "SCU-56" (Included in optional SCU-58)...(When connecting to the USB jack of the computer.)

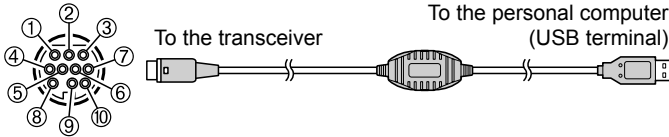

- Make sure to turn the transceiver OFF before connecting any cables.
- When using the SCU-56 PC connection cable, install the designated driver on the computer. Download the driver and installation manual from the Yaesu website.

Transmitting GPS location information

The GPS position data (latitude/longitude) of this station can be output from the serial DATA jack on the rear of the transceiver.

1. Press and hold the  key.
2. Rotate the Right **DIAL** knob to select **[70 COM PORT]** then press the Right **DIAL** knob.
3. Rotate the Right **DIAL** knob to select **[SPEED]** then press the Right **DIAL** knob.
4. Rotate the Right **DIAL** knob to select the desired communication speed.

The setting changes in the following order:

4800bps → 9600bps → 19200bps → 38400bps → 57600bps



Factory default value: 9600bps

5. Press the  key.
6. Rotate the Right **DIAL** knob to select **[OUTPUT]** then press the Right **DIAL** knob.
7. Rotate the Right **DIAL** knob to select **[GPS OUT]** then press the Right **DIAL** knob.

The setting changes in the following order:

OFF → GPS OUT → PACKET → WAYPOINT

Factory default value: OFF

8. Press any key or **DIAL** knob, other than the  or  key, to save the settings and return to normal operation.

Transmits the location information data. The location data is output to the computer at about one second intervals.



An operating software using NMEA-0183 standard GGA and RMC sentence is required to use the position information.

Using the transceiver for packet communications

A TNC (Terminal Node Controller) may be connected to the transceiver to enable packet communications.

● Preparation

- TNC
- Computer
- Data cable* ... Prepare a cable suitable for the connected device.

*The following optional products are available.

- Data cable "CT-164"

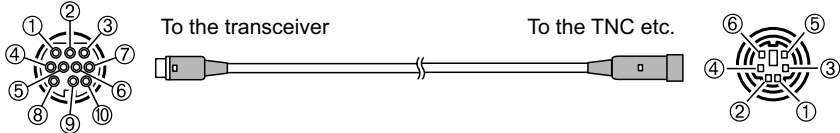

- ① PKD (packet data input)
- ② GND
- ③ PKS(PTT)
- ④ RX 9600 (9600 bps packet data output)
- ⑤ RX 1200 (1200 bps packet data output)
- ⑥ PK SQL (squelch control)
- ⑦ -
- ⑧ -
- ⑨ -
- ⑩ -

- ① PKD (packet data input)
- ② GND
- ③ PKS(PTT)
- ④ RX 9600 (9600 bps packet data output)
- ⑤ RX 1200 (1200 bps packet data output)
- ⑥ PK SQL (squelch control)

- Data cable "CT-163"

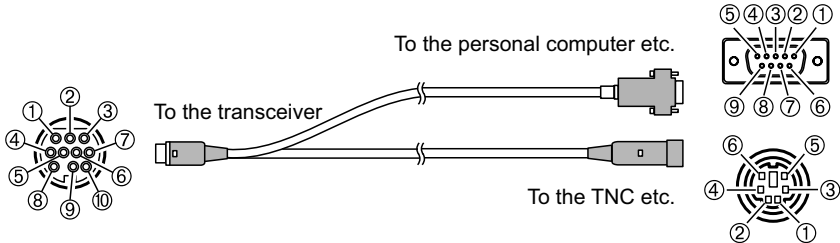

- ① PKD (packet data input)
- ② GND
- ③ PKS(PTT)
- ④ RX 9600 (9600 bps packet data output)
- ⑤ RX 1200 (1200 bps packet data output)
- ⑥ PK SQL (squelch control)
- ⑦ TXD (serial data output [transceiver → PC])
- ⑧ RXD (serial data input [transceiver ← PC])
- ⑨ CTS (data communication control)
- ⑩ RTS (data communication control)

Dsub 9 pin

- ① -
- ② TXD (serial data output [transceiver → PC])
- ③ RXD (serial data input [transceiver ← PC])
- ④ -
- ⑤ GND
- ⑥ -
- ⑦ CTS (data communication control)
- ⑧ RTS (data communication control)
- ⑨ -

DIN 6 pin

- ① PKD (packet data input)
- ② GND
- ③ PKS(PTT)
- ④ RX 9600 (9600 bps packet data output)
- ⑤ RX 1200 (1200 bps packet data output)
- ⑥ PK SQL (squelch control)

- Data cable “CT-167” (optional)

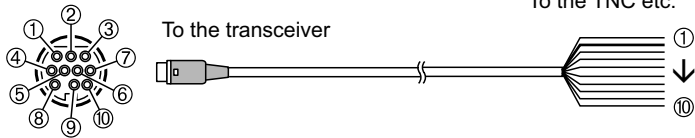



① PKD (packet data input)	① Brown PKD (packet data input)
② GND	② Black thick wire GND
③ PKS(PTT)	③ Red PKS (PTT)
④ RX 9600 (9600 bps packet data output)	④ Orange RX 9600 (9600 bps packet data output)
⑤ RX 1200 (1200 bps packet data output)	⑤ Yellow RX 1200 (1200 bps packet data output)
⑥ PK SQL (squelch control)	⑥ Green PK SQL (squelch control)
⑦ TXD (serial data output [transceiver → PC])	⑦ Blue TXD (serial data output [transceiver → PC])
⑧ RXD (serial data input [transceiver ← PC])	⑧ Grey RXD (serial data input [transceiver ← PC])
⑨ CTS (data communication control)	⑨ White CTS (data communication control)
⑩ RTS (data communication control)	⑩ Black RTS (data communication control)

- Make sure to turn the power to the radio OFF before connecting.
- Refer to the TNC operating manual for instruction on connecting the TNC to a personal computer.
- RF receive interference may occur because of noise occurring in the personal computer. When signals cannot be received normally, keep the personal computer at a distance away from the radio and use a photo-coupler and noise filter to connect.



● Packet communication settings

1. Press and hold the  key.
2. Rotate the Right **DIAL** knob to select **[71 DATA BAND]** then press the Right **DIAL** knob.
3. Rotate the Right **DIAL** knob to select **[DATA]**, then press the Right **DIAL** knob.
4. Rotate the Right **DIAL** knob to select the band to be used for the packet communication.
The setting changes in the following order:
MAIN BAND → SUB BAND → A-BAND FIX → B-BAND FIX
 - Refer to “**71 DATA BAND**” (page 49) for details.
5. Press the  key twice.
6. Rotate the Right **DIAL** knob to select **[72 DATA SPEED]** then press the Right **DIAL** knob.
7. Rotate the Right **DIAL** knob to select **[DATA]**, then press the Right **DIAL** knob.
8. Rotate the Right **DIAL** knob to select the packet communication speed.
The setting will switch between “1200 bps” and “9600 bps” then rotate the Right **DIAL** knob.
Factory default value: 1200bps
9. Press the  key twice.
10. Rotate the Right **DIAL** knob to select **[73 DATA SQL]** then press the Right **DIAL** knob.
11. Rotate the Right **DIAL** knob to select **[DATA]** then press the Right **DIAL** knob.
12. Rotate the Right **DIAL** knob to select the squelch detection method for the packet communication.
The setting switches between “RX BAND” and “TX/RX BAND”.
 - Refer to “**73 DATA SQL**” (page 51) for details.

- Factory default value: RX BAND

13. Press the  key.



14. Rotate the Right **DIAL** knob to select [TX] then press the Right **DIAL** knob.

15. Rotate the Right **DIAL** knob to select the squelch detection method for the packet communication.

The setting switches between “ON” and “OFF”.

- Refer to “**73 DATA SQL**” (page 51) for details.

- Factory default value: ON

16. Press any key or **DIAL** knob, other than the  or  key, to save the settings and return to normal operation.

This completes the packet communication settings.

When transmitting a large volume of packet data, the transmission time gets longer, and the transceiver may heat up. When transmission continues for a long period of time, the overheating prevention circuit will act to lower the transmit power output. When transmission is continued further, transmission will be suspended automatically, and the transceiver will go into the receive mode to prevent failure due to overheating. When the overheating prevention circuit is activated and the radio goes into the receive mode, either switch the power OFF, or wait in receive mode until the transceiver cools.



Updating the transceiver firmware

When updated firmware is available, the transceiver can be updated by connecting it to a personal computer. Download the latest version of the firmware and the firmware installation manual from the YAESU website.

Setup Menu

The Set Mode permits configuring the various functions to accommodate individual operating needs and preferences.



Setup Menu Operation

1. Press and hold the  key.
The SETUP MENU screen will be displayed.
2. Rotate the Right **DIAL** knob to select the desired item in the Setup Menu.

- Press the  key to return to the previous screen.
- Rotate the Left **DIAL** knob, or press the [UP] / [DWN] key on the microphone to scroll through the 16 categories in the Setup Menu (See below):

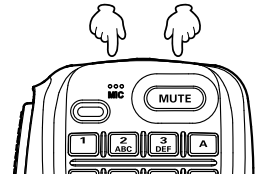
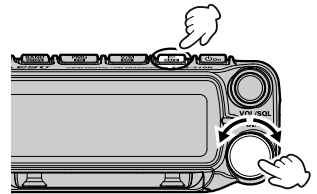
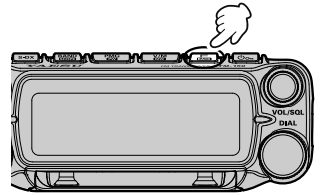
DISPLAY ↔ **TX** ↔ **RX** ↔ **MEMORY** ↔ **CONFIG** ↔
↔ **AUDIO** ↔ **SIGNALING** ↔ **SCAN** ↔ **DIGITAL** ↔
↔ **GM** ↔ **WIRES-X** ↔ **DATA** ↔ **APRS** ↔
↔ **SD CARD** ↔ **OPTION** ↔ **CLONE/RESET**



3. Press the Right **DIAL** knob.
4. When there is no deeper level of menu items, go to step 5.
When there is a deeper level of menu items, rotate the Right **DIAL** knob to select the desired item, then press the Right **DIAL** knob.
5. Rotate the Right **DIAL** knob to change the setting value.
6. Press any key or **DIAL** knob, other than the  or  key, to save the settings and return to normal operation.

Tables of Setup Menu Operations

Menu Number / Item	Description	Selectable options (Options in bold are the default settings)
--------------------	-------------	--

DISPLAY

1 KEYPAD	Enter frequency directly or display memory channel list.	–
2 LCD DIMMER	Sets the display and key button brightness.	MAX / MID / OFF
3 LCD CONTRAST	Sets the screen contrast.	1 - 5 - 9
4 BAND SCOPE	Scope Display width setting.	WIDE / NARROW
5 S-METER SYMBOL	Selects the S- & TX PO meter Symbol.	
6 BACKLIGHT COLOR	Set the display color.	AMBER / WHITE
7 COMPASS	Set the compass display of the APRS pop-up screen.	NORTH UP / HEADING UP
8 GPS INFORMATION	GPS Information screen display.	–

TX

9 TX POWER	Set the transmit power level.	LOW / MID / HIGH
10 AMS TX MODE	Set the AMS transmission mode.	AUTO / TX FM FIXED/ TX DN FIXED
11 MIC GAIN	Microphone sensitivity setting.	MIN / LOW / NORMAL / HIGH / MAX
12 VOX	VOX function settings.	VOX: OFF / LOW / HIGH DELAY: 0.5s / 1.0s / 1.5s / 2.0s / 2.5s / 3.0s VOX MIC: FRONT / REAR
13 AUTO DIALER	DTMF code automatic transmit setting.	ON / OFF
14 TOT	TX time out setting.	OFF / 1min / 2min / 3min / 5min / 10min / 15min / 20min / 30min (3min: USA version)
15 DIGITAL VW	Turn the VW mode selection ON or OFF.	ON / OFF

RX

16 FM BANDWIDTH	Set the FM transmit modulation level.	WIDE / NARROW
17 RX MODE	Select the receive mode.	AUTO / FM / AM
18 SUB BAND		
SUB BAND	Sub Band ON/OFF.	OFF / ON
SUBBAND MUTE	Sub Band mute setting	OFF / ON
19 AUDIO EQUALIZER		
FRONT TONE	Adjust the sound quality of the Control head speaker.	OFF / FLAT / HI PITCH / LO PITCH / BPF
REAR TONE	Adjust the sound quality of the Main body speaker.	FLAT / HI PITCH / LO PITCH / BPF / 1kHz LPF / 700Hz LPF
AESS PHASE	Sets the time delay between the audio output of the control head speaker and the main unit speaker.	OFF / 1.25ms to 20.00ms (10.00ms)

MEMORY

20 HOME CH	Recall the home channel.	–
21 MEMORY LIST	Displays the Memory channel list screen.	–
22 MEMORY LIST MODE	Displays a list of memory channels in memory mode.	ON / OFF
23 PMG		
PMG TIMER	Scan resume time after there is no signal when receiving in PMG mode simultaneously.	0.5sec / 1sec / 2sec

Menu Number / Item	Description	Selectable options (Options in bold are the default settings)
PMG CLEAR	Cancel the registration of all PMG channels.	-
PMG HOLD	Select the holding time of the previously received signals bar graph.	2sec / 5sec / 10sec / 20sec / 30sec

CONFIG

24 BEEP	Beep volume setting.	OFF / LOW / HIGH
25 BAND SKIP	Set the frequency bands that can be selected.	AIR: ON / OFF VHF: ON / OFF UHF: ON / OFF OTHER: ON / OFF
26 RPT ARS	Repeater auto shift setting.	OFF / AUTO
27 RPT SHIFT	Repeater shift direction setting.	AUTO / -RPT / +RPT
28 RPT SHIFT FREQ	Repeater TX offset setting.	0.00MHz to 99.95MHz
29 RPT REVERSE	Reverses the transmit and receive frequencies while working through a repeater.	NORMAL / REVERSE
30 MIC PROGRAM KEY	Microphone P1 / P2 / P3 / P4 keys programable settings.	OFF / 2nd PTT / GM / REC/STOP / SCAN / HOME CH / RPT SHIFT / REVERSE / TX POWER / SQL OFF / T-CALL / VOICE* / D_X / WX / STN LIST / MSG LIST / REPLY / MSG EDIT / DW (*requires optional FVS-2) P1: 2nd PTT P2: HOME CH P3: D_X P4: WX (T-CALL: European version)
31 DATE & TIME ADJUST	Set the date and time.	-
32 DATE & TIME FORMAT	Set the date and time display formats.	Date: mmm/dd/yyyy / yyyy/mmm/dd / dd/mmm/yyyy / yyyy/dd/mmm Time: 24hour / 12hour
33 TIME ZONE	Time zone setting.	UTC -14:00 to ±0:00 to +14:00
34 STEP	Frequency tuning step.	AUTO / 5.00 kHz / 6.25 kHz / (8.33 kHz) / 10.00 kHz / 12.50 kHz / 15.00kHz / 20.00kHz / 25.00 kHz / 50.00 kHz / 100 kHz (8.33kHz: only for Air band)
35 CLOCK TYPE	Clock shift setting.	A / B
36 UNIT	Display unit setting.	METRIC / INCH (Depends on the transceiver version)
37 APO	Automatic power OFF time setting.	OFF / 0.5hour to 2.0hour (0.5 hour steps) 2.0hour to 12.0hour (1.0 hour steps)
38 GPS DATUM	GPS function positioning selection.	WGS-84 / TOKYO MEAN
39 GPS LOG	GPS access time setting.	OFF / 1sec / 2sec / 5sec / 10sec / 30sec / 60sec

AUDIO

40 RECORDING	Voice record function settings.	BAND: MAIN / SUB / MAIN+SUB MIC: ON / OFF
41 REC/STOP	Start and stop recording.	-
42 REAR SP OUT	Output level of the main body speaker	0% to 100%
43 FRONT SP MUTE	Front speaker operation settings when external speakers are connected.	CONTINUE / AUTO MUTE

SIGNALING

44 DTMF	Load DTMF Autodialer Memories.	-
----------------	--------------------------------	---

Menu Number / Item	Description	Selectable options (Options in bold are the default settings)
45 DTMF MEMORY	Set the DTMF auto dialer channel and code (16 characters).	1 to 9
46 SQL TYPE	Select a squelch type.	OFF / TONE ENC / TONE SQL / REV TONE / DCS / PR FREQ / PAGER / (DCS ENC) / (TONE DCS) / (DCS TSQL) *The options in the parentheses are available when the SQL expansion is ON.
47 TONE SQL FREQ or DCS CODE	Set the CTCSS Tone Frequency or the DCS code.	CTCSS: 67.0Hz to 254.1Hz (100Hz) DCS: 023 to 754
48 SQL EXPANSION	Separate squelch type setting for transmit and receive.	ON / OFF
49 PAGER CODE	Pager individual code settings.	RX-CODE 1: 01 - 05 - 50 RX-CODE 2: 01 - 47 - 50 TX-CODE 1: 01 - 05 - 50 TX-CODE 2: 01 - 47 - 50
50 PR FREQUENCY	User programmed reverse tone frequency.	300Hz - 1500Hz - 3000Hz
51 BELL RINGER	Recall sound length setting.	OFF / 1time / 3times / 5times / 8times / CONTINUOUS
52 WX ALERT	Weather alert operation setting.	ON / OFF

SCAN

53 SCAN	Engages the Scan operation.	—
54 DUAL RECEIVE MODE	Dual receive operation setting.	OFF / PRIORITY SCAN
55 DUAL RX INTERVAL	Dual receive reception interval setting. (Only enabled when "41 DUAL RECEIVE MODE" is set to "PRIORITY SCAN".)	0.5sec / 1.0sec / 2.0sec / 3.0sec / 5.0sec / 7.0sec / 10sec
56 PRIORITY REVERT	The transmission operation during dual receive always transmits on the home channel.	OFF / ON
57 SCAN RESUME	Set the resume operation after scanning stops on a signal.	BUSY / HOLD / 1sec / 3sec / 5sec

DIGITAL

58 DIGITAL POPUP	Information screen popup time.	OFF / 2sec / 4sec / 6sec / 8sec / 10sec / 20sec / 30sec / 60sec / CONTINUE
59 LOCATION SERVICE	Set whether to send your current location in digital mode.	OFF / ON
60 STANDBY BEEP	Standby Beep setting.	OFF / ON

GM

Refer to the separate Operating Manual GM Edition for details on the functions.

61 DP-ID LIST	Displays the DP-ID list screen.	—
62 RANGE RINGER	Set the bell sound when checking for stations within sphere of communications.	OFF / ON
63 RADIO ID	Specific transceiver ID is displayed.	— (cannot be edited)
64 LOG LIST	Display a list of recorded voices, received messages and images.	—

WIRES-X

Refer to the separate Operating Manual WIRES-X Edition for details on the functions.

65 RPT/WIRES FREQ	Set the frequency to be used for Repeater / WIRES-X.	MANUAL / PRESET
--------------------------	--	------------------------

Menu Number / Item	Description	Selectable options (Options in bold are the default settings)
FREQUENCY	Register the WIRES-X preset frequency.	Preset frequency: 146.550MHz 446.500MHz
66 SEARCH SETUP	Set the WIRES ROOM selection method.	HISTORY / ACTIVITY
67 EDIT CATEGORY TAG	Edit the category tag.	C1 to C5
68 DELETE ROOM/NODE	Delete a registered category.	C1 to C5
69 WIRES DG-ID	Set the DG-ID number for WIRES-X.	AUTO / 01 to 99

DATA

70 COM PORT	COM port settings.	SPEED: 4800bps / 9600bps / 19200bps / 38400bps / 57600bps OUTPUT: OFF / GPS OUT / PACKET /WAYPOINT WP FORMAT: NMEA 9 / NMEA 8 / NMEA 7 / NMEA 6 WP FILTER: ALL / MOBILE / FREQUENCY / OBJECT/ITEM / DIGIPEATER / VoIP / WEATHER /YAESU / CALL RINGER / RANGE RINGER
71 DATA BAND	APRS/DATA band selection settings.	APRS: MAIN BAND / SUB BAND / A-BAND FIX / B-BAND FIX DATA: MAIN BAND / SUB BAND / A-BAND FIX / B-BAND FIX
72 DATA SPEED	APRS/DATA communication baud rate settings.	APRS: 1200 bps / 9600 bps DATA: 1200 bps / 9600 bps
73 DATA SQL	Squelch detection settings.	APRS: RX BAND / TX/RX BAND DATA: RX BAND / TX/RX BAND TX: ON / OFF

APRS

Refer to the separate Operating Manual APRS Edition for details on the functions.

74 APRS DESTINATION	Model code display Non-editable.	APY310 (FIX)
75 APRS FILTER	Filter function settings.	Mic-E: ON / OFF POSITION: ON / OFF WEATHER: ON / OFF OBJECT: ON / OFF ITEM: ON / OFF STATUS: ON / OFF OTHER: ON / OFF RANGE LIMIT: OFF / 1 / 10 / 100 / 1000 / 3000 (km / mi) ALTNET: ON / OFF
76 APRS MESSAGE TEXT	Standard message text input.	1 to 8 channels
77 APRS MODEM	Set APRS function ON/OFF.	OFF / ON
78 APRS MUTE	Set audio mute for APRS band.	OFF / ON

Menu Number / Item	Description	Selectable options (Options in bold are the default settings)
79 APRS POPUP	Beacons and messages Pop-up display time setting.	BEACON: OFF / 3sec / 5sec / 10sec / HOLD CALL 3sec / CALL 5sec CALL 10sec / CALL HOLD MESSAGE: OFF / 3sec / 5sec / 10sec / HOLD CALL 3sec / CALL 5sec CALL 10sec / CALL HOLD MYPACKET: OFF / ON
80 APRS RINGER	Set bell sound when beacons are received.	TX BEACON: ON / OFF TX MESSAGE: ON / OFF RX BEACON: ON / OFF RX MESSAGE: ON / OFF MY PACKET: ON / OFF CALL RINGER: ON / OFF RANGE RINGER: OFF / 1 / 5 / 10 / 50 / 100 (km / mi) MSG VOICE: ON / OFF
81 APRS RINGER (CS)	Call sign setting for CALL RINGER.	1 - 8 stations
82 APRS TX DELAY	Data transmit delay time setting.	100ms / 150ms / 200ms / 250ms / 300ms / 400ms / 500ms / 750ms / 1000ms
83 APRS UNITS	APRS display unit settings.	POSITION: dd°mm.mm' / dd°mm'ss" DISTANCE: km* / mile* SPEED: km/h* / mph* / knot* ALTITUDE: m* / ft* BARO: hPa* / mb* / mmHg* / inHg* TEMP: °C* / °F* RAIN: mm* / inch* WIND: m/s* / mph* / knot* *(Depends on the transceiver version)
84 BEACON INFORMATION	Transmit beacon information settings.	AMBIGUITY: OFF / 1 digit / 2 digits / 3 digits / 4 digits SPEED/COURSE: ON / OFF ALTITUDE: ON / OFF
85 BEACON STATUS TEXT	Status text input settings.	SELECT: OFF / TEXT 1 - 5 TX RATE: 1/1 - 1/8 / 1/2(FREQ)- 1/8(FREQ) TEXT 1 - 5: NONE / FREQUENCY / FREQ & SQL & SHIFT

Menu Number / Item	Description	Selectable options (Options in bold are the default settings)
86 BEACON TX SET	Beacon automatic transmit / Manual transmit switch.	AUTO: OFF / ON / (SmartBeaconing)* INTERVAL: 30sec / 1min / 2min / 3min / 5min / 10min / 15min / 20min / 30min / 60min PROPORTIONAL: ON / OFF DECAY: ON / OFF LOW SPEED: 1 - 3 - 99 (km/h / mph / knot) RATE LIMIT: 5sec - 30sec - 180sec * The option in the parentheses is available when the "101 SmartBeaconing" is TYPE1, TYPE 2 or TYPE 3, and the "97 MY POSITION SET" is GPS.
87 DIGI PATH	Digital repeater route setting.	OFF / WIDE1-1 / WIDE1-1, WIDE2-1 / PATH 1 / PATH 2 / PATH 3 / PATH 4 / FULL 1 / FULL 2
88 DIGI PATH 1	Digital repeater route address setting.	ADDRESS 1: - ADDRESS 2: -
89 DIGI PATH 2		
90 DIGI PATH 3		ADDRESS 1: - to ADDRESS 8: -
91 DIGI PATH 4		
92 DIGI PATH FULL 1		
93 DIGI PATH FULL 2		
94 CALLSIGN (APRS)	My call sign setting.	***** - **
95 MESSAGE GROUP	Group filter setting for received messages.	GROUP 1: ALL***** GROUP 2: CQ***** GROUP 3: QST***** GROUP 4: YAESU**** GROUP 5: ----- GROUP 6: ----- BULLETIN 1: BLN?***** BULLETIN 2: BLN?----- BULLETIN 3: BLN?-----
96 MESSAGE REPLY	Set automatic response to received messages.	REPLY: OFF / ON CALLSIGN: *****_* REPLY TEXT: -
97 MY POSITION SET	My position setting.	GPS / MANUAL
98 MY POSITION	My position manual setting.	LATITUDE: N 0°00. 00' (' 00") LONGITUDE: E 0°00. 00' (' 00")
99 MY SYSBOL	My symbol setting.	ICON 1: [/>] Car ICON 2: [/R] REC.Vehicle ICON 3: [/ -] House QTH (VHF) USER: [YY] Yaesu Radios
100 POSITION COMMENT	Set position comment.	Off Duty / En Route / In Service / Returning / Committed / Special / Priority / Custom 0 to Custom 6 / EMERGENCY!

Menu Number / Item	Description	Selectable options (Options in bold are the default settings)
101 SmartBeaconing	Smart beaconing settings.	STATUS: OFF / TYPE1 / TYPE2 / TYPE3 * For details on the following setting items for each type, refer to the APRS Instruction Manual. LOW SPEED, HIGH SPEED, SLOW RATE, FAST RATE, TURN ANGLE, TURN SLOPE, TURN TIME
102 SORT FILTER	Sort function / Filter function settings.	SORT: TIME / CALLSIGN / DISTANCE FILTER: ALL / MOBILE / FREQUENCY/ OBJECT/ITEM / DIGIPEATER/ VoIP / WEATHER / YAESU/ OTHER PACKET / CALL RINGER / RANGE RINGER / 1200 bps / 9600 bps
103 VOICE ALERT	Voice alert function settings.	VOICE ALERT: NORMAL / TONE SQL / DCS / RX-TSQL / RX-DCS TONE SQL: 67.0Hz - 254.1Hz (100.0Hz) DCS: 023 - 754
104 STATION LIST	Displays the APRS Station list screen.	-
105 MESSAGE LIST	Displays the APRS Message list screen.	-
106 BEACON TX SELECT	Beacon automatic transmit / Manual transmit switch.	MANUAL / AUTO / (SmartBeaconing)* * The option in the parentheses is available when the "101 SmartBeaconing" is TYPE1, TYPE 2 or TYPE 3, and the "97 MY POSITION SET" is GPS.
107 BEACON TX	Manual beacon transmission (one time)	-

SD CARD

108 BACKUP

WRITE TO SD	Saves the transceiver setting information to a microSD memory card.	
ALL	Copies all data.	
MEMORY	Copies only the memory channels.	
SETUP	Copies only the set-up menu settings.	
READ FROM SD	Loads the information to the transceiver from a microSD memory card.	
ALL	Copies all data.	
MEMORY	Copies only the memory channels.	
SETUP	Copies only the set-up menu settings.	
109 SD INFORMATION	Displays the total capacity and free space of the microSD Card.	-
110 FORMAT	Initializing the micro-SD card.	-

OPTION

111 Bluetooth (Requires optional Bluetooth Unit BU-5)

Bluetooth	Bluetooth headset setting.	OFF / ON
DEVICE	Bluetooth device list.	-

Menu Number / Item	Description	Selectable options (Options in bold are the default settings)
AUDIO	Set whether received audio is heard from both the Bluetooth headset and the transceiver speaker, or only from the connected Bluetooth device.	AUTO / FIX
112 VOICE MEMORY (Requires optional Voice Guide Unit FVS-2)		
PLAY/REC	Recording operation settings.	FREE 5min / LAST 30sec
ANNOUNCE	Setting conditions for frequency announcement.	OFF / MANUAL / AUTO
LANGUAGE	Setting the language to announce.	ENGLISH / JAPANESE
VOLUME	Setting the announcement volume.	HIGH / MID / LOW
RX MUTE	Setting to mute received audio during announcements and playback.	ON / OFF
113 FVS REC	Start recording the received audio.	–
114 TRACK SELECT	Selecting the audio track to play.	ALL / 1 - 8
115 FVS PLAY	Start playing the recorded sound	–
116 FVS STOP	Stop recording / playing	–
117 FVS CLEAR	Erase all recorded audio	–
118 VOICE GUIDE	The frequency of the operating band will be announced.	–

CLONE/RESET

119 This → Other	Send all settings to other FTM-310DR/DE	–
120 Other → This	Receive all settings from other FTM-310DR/DE	–
121 CALLSIGN	My call sign setting. (10 characters)	*****
122 MEMORY CH RESET	Erase registered memory channels.	–
123 APRS RESET	Return APRS settings to default.	–
124 CONFIG SET	Save configuration.	–
125 CONFIG RECALL	Recall configuration.	–
126 SOFTWARE VERSION	Display the software version.	Main Ver. / Sub Ver.
127 FACTORY RESET	Return all settings to factory default.	–

Setup Menu Operations

DISPLAY

1 KEY PAD

The screen for direct input of frequency is displayed.

Select the **[MEM CH]** on this screen and press the Right **DIAL** knob to open the direct input of Memory Channel number screen.

Select the **[MEM LIST]** on this screen and press the Right **DIAL** knob to open the memory channel list screen.

1. Press and hold the  key → **[1 KEYPAD]** → Press the Right **DIAL** knob.
2. Rotate the Right **DIAL** knob to select a number and press the Right **DIAL** knob to enter.

NOTE: This item is registered in the custom function menu by factory setting.

2 LCD DIMMER

The brightness of the display and key buttons can be changed.

1. Press and hold the  key → **[2 LCD DIMMER]** → Press the Right **DIAL** knob.
2. Rotate the Right **DIAL** knob to select the brightness from the following 3 levels.

MAX / MID / OFF

3 LCD CONTRAST

Setting of the display contrast level.

1. Press and hold the  key → **[3 LCD CONTRAST]** → Press the Right **DIAL** knob.
2. Rotate the Right **DIAL** knob to select the contrast level.

1 / 2 / 3 / 4 / **5** / 6 / 7 / 8 / 9

4 BAND SCOPE

Set the number of channels to be displayed when the BAND SCOPE function is used.

1. Press and hold the  key → **[4 BAND SCOPE]** → Press the Right **DIAL** knob.
2. Rotate the Right **DIAL** knob to select the number of channels to search.

WIDE	47 channels (VFO mode), 23 channels (Memory mode)
NARROW	23 channels (VFO mode), 13 channels (Memory mode)

Refer to the Operating Manual for details.

5 S-METER SYMBOL

Select the S & TX PO meter symbol.

1. Press and hold the  key → **[5 S-METER SYMBOL]** → Press the Right **DIAL** knob.
2. Rotate the right **DIAL** knob to select the desired meter symbol type.



6 BACKLIGHT COLOR

Changes the background color of the display.

1. Press and hold the  key → [6 BACKLIGHT COLOR] → Press the Right **DIAL** knob.
2. Rotate the Right **DIAL** knob to select the display color.
AMBER / **WHITE**

7 COMPASS

Set the compass display.

1. Press and hold the  key → [7 COMPASS] → Press the Right **DIAL** knob.
2. Rotate the Right **DIAL** knob to select the desired setting.

HEADING UP	The heading direction is indicated at the top of the compass.
NORTH UP	The north direction is indicated at the top of the compass.

The default setting: HEADING UP

8 GPS INFORMATION

Displays the status of signals received from GPS satellites and related information.

1. Press and hold the  key → [8 GPS INFORMATION] → Press the Right **DIAL** knob.

9 TX POWER

Set the transmit power output.

1. Press and hold the  key → [9 TX POWER] → Press the Right **DIAL** knob.
2. Rotate the Right **DIAL** knob to select the TX power output.
 “LOW” ↔ “MID” ↔ “HIGH”

NOTE: This item is registered in the custom function menu by factory setting.

10 AMS TX MODE

When operating in the AMS function, the transmit mode may be selected:

1. Press and hold the  key → [10 AMS TX MODE] → Press the Right **DIAL** knob.
2. Rotate the Right **DIAL** knob to select the AMS transmit mode.

Transmit Mode	Transmit	Receive
AUTO (default)	Automatically transmits in the communication mode selected by the AMS function.	Automatically selects the receive mode corresponding to the received signal.
TX FM FIXED	Always transmits in the analog FM mode.	
TX DN FIXED (TX DIGITAL)	Always transmits in the DN mode.	

Refer to the Operating Manual for details.

11 MIC GAIN

The sensitivity (gain) of the microphone can be adjusted.

1. Press and hold the  key → [11 MIC GAIN] → Press the Right **DIAL** knob.
2. Rotate the Right **DIAL** knob to select the desired setting.
 The sensitivity can be selected from the following 5 levels.

MIN / LOW / **NORMAL** / HIGH / MAX

12 VOX

Set the VOX (Voice Operated Transmit) function ON/OFF, and VOX delay time.

1. Press and hold the  key → [12 VOX] → Press the Right **DIAL** knob.

Refer to the Operating Manual for details.

13 AUTO DIALER

Set method (Auto or Manual) to transmit the registered DTMF code.

1. Press and hold the  key → [13 AUTO DIALER] → Press the Right **DIAL** knob.
2. Rotate the Right **DIAL** knob to select the desired setting.

ON	The auto dialer function is enabled.
OFF	The auto dialer function is disabled.

For details, see “Setting the auto dialer function” (page 12).

14 TOT

The transceiver will automatically return to receive after transmitting continuously for a specified time.

1. Press and hold the  key → [14 TOT] → Press the Right **DIAL** knob.
2. Rotate the Right **DIAL** knob to select the desired setting.

OFF / 1 min / 2 min / 3 min / 5 min / 10 min / 15 min / 20 min / 30 min



When the time-out-timer is active, a beep is sounded when a continuous transmission nears the set time. About 10 seconds later, the transceiver returns to the receive mode.

The default settings depend on the transceiver version.

15 DIGITAL VW

Set the digital voice VW (Voice FR) mode selection.

1. Press and hold the  key → [15 DIGITAL VW] → Press the Right **DIAL** knob.
2. Rotate the Right **DIAL** knob to select the desired setting.

ON	The digital voice VW (Voice FR) mode may be selected.
OFF	The digital voice VW (Voice FR) mode may not be selected.

16 FM BANDWIDTH

The modulation can be set to half of its usual level.

Select "WIDE" for normal amateur radio operation.

1. Press and hold the  key → [16 FM BANDWIDTH] → Press the Right **DIAL** knob.
2. Rotate the **FUNC** knob to select the desired setting.

WIDE	Normal transmit modulation level.
NARROW	Modulation is half of the normal level.

17 RX MODE

Manually switch to a suitable mode (radio wave type) for the operating frequency band.

1. Press and hold the  key → [17 RX MODE] → Press the Right **DIAL** knob.
2. Rotate the **FUNC** knob to select the mode.

AUTO	Automatically switches the modulation mode to match the frequency band.
FM	Switches to the FM mode.
AM	Switches to the AM mode.

18 SUB BAND

The Sub Band display (lower part of the screen) can be hidden. Also, while receiving a signal on the Main Band, the Sub Band audio can be automatically muted.

1. Press and hold the  key → [18 SUB BAND] → Press the Right **DIAL** knob.
The parameter settings screen appears.

SUB BAND

The Sub Band display is hidden.

1. Rotate the Right **DIAL** knob to select [SUB BAND] then Press the Right **DIAL** knob.
2. Rotate the Right **DIAL** knob to select the desired setting then press the Right **DIAL** knob.

OFF	The Sub Band (Lower part of the screen) is not displayed.
ON	The Sub Band (Lower part of the screen) is displayed.

SUBBAND MUTE

The receive audio of the Sub Band can be automatically muted when receiving signals in the Main Band.

1. Rotate the Right **DIAL** knob to select [SUBBAND MUTE] then press the Right **DIAL** knob.
2. Rotate the Right **DIAL** knob to select the desired setting.

OFF	The Sub Band audio will not be muted when a signal is received on the Main Band.
ON	The Sub Band audio will be muted when a signal is received on the Main Band.

19 AUDIO EQUALIZER

Set up the AESS dual speaker system that uses both the front speakers and the main unit speakers.

1. Press and hold the  key → [19 AUDIO EQUALIZER] → Press the Right **DIAL** knob.
2. Press the Right **DIAL** knob.
3. Rotate the Right **DIAL** knob to set the sound quality of the front speaker.

OFF	Standard sound quality without AESS.
FLAT	Use AESS without changing sound quality.
HI PITCH	Emphasizes high frequencies.
LO PITCH	Emphasizes low frequencies
BPF	Attenuates high and low frequencies

4. Press the  key.
5. Similarly, rotate the Right **DIAL** knob to select each item of “REAR TONE” and “AESS PHASE”, then press the Right **DIAL** knob.

FRONT TONE

OFF	Standard sound quality without AESS. (When set to OFF, only “REAR OUT” cannot be set.)
FLAT	Use AESS without changing sound quality.
HI PITCH	Emphasizes high frequencies.
LO PITCH	Emphasizes low frequencies
BPF	Attenuates high and low frequencies

REAR TONE

FLAT	Use AESS without changing sound quality.
HI PITCH	Emphasizes high frequencies.
LO PITCH	Emphasizes low frequencies
BPF	Attenuates high and low frequencies
1KHz LPF	Cuts high frequencies above 1kHz
700Hz LPF	Cuts high frequencies above 700Hz

AESS PHASE

OFF	Use AESS without changing the time delay.
1.25ms - 20.00ms	Sets the time delay between the audio output of the control head speaker and the main unit speaker..

MEMORY

20 HOME CH

Recalls the home channel of the current band.

1. Press and hold the  key → **[20 HOME CH]** → Press the Right **DIAL** knob.

21 MEMORY LIST

Displays the Memory channel list screen.

1. Press and hold the  key → **[21 MEMORY LIST]** → Press the Right **DIAL** knob.

22 MEMORY LIST MODE

Set the memory channel list to be displayed by rotating the **DIAL** knob, confirming the contents of the memory, and then press **DIAL** knob to recall the memory channel.

1. Press and hold the  key → **[22 MEMORY LIST MODE]** → Press the Right **DIAL** knob.

Refer to the Operating Manual for details.

23 PMG

Cancel the registration of all PMG channels.

1. Press and hold the  key → **[23 PMG]** → Press the Right **DIAL** knob.

The parameter settings screen appears.

PMG TIMER

Scan resume time after there is no signal when receiving in PMG mode simultaneously.

1. Rotate the Right **DIAL** knob to select **[PMG TIMER]** then Press the Right **DIAL** knob.
2. Rotate the Right **DIAL** knob to select the desired setting.

0.5sec / 1sec / 2sec

PMG CLEAR

Cancel the registration of all PMG channels.

1. Rotate the Right **DIAL** knob to select **[PMG CLEAR]** then Press the Right **DIAL** knob.
The confirmation screen will be displayed.
2. Rotate the Right **DIAL** knob to select **[OK]**, then press the Right **DIAL** knob.

PMG HOLD

Select the holding time of the previously received signals bar graph.

1. Rotate the Right **DIAL** knob to select **[PMG HOLD]** then Press the Right **DIAL** knob.
2. Rotate the Right **DIAL** knob to select the desired setting.

2sec / 5sec / 10sec / 20sec / 30sec

CONFIG

24 BEEP

Adjust the volume of the beep that sounds when a key is pressed.

1. Press and hold the  key → [24 BEEP] → Press the Right **DIAL** knob.
2. Rotate the Right **DIAL** knob to select the desired setting.

The Beep volume can be selected from 3 levels.

OFF / **LOW** / HIGH

25 BAND SKIP

Set the band selected when the  key is pressed.

1. Press and hold the  key → [25 BAND SKIP] → Press the Right **DIAL** knob.
2. Rotate the Right **DIAL** knob to select the band to be set with a Press the Right **DIAL** knob.
3. Rotate the Right **DIAL** knob to set "ON" (selectable) or "OFF" (not selectable).

AIR: OFF / **ON** (108MHz - 137MHz)

VHF: OFF / **ON** (137MHz - 174MHz)

UHF: OFF / **ON** (400MHz - 550MHz)

OTHER: OFF / **ON** (174MHz - 400MHz)

26 RPT ARS

Set the auto repeater shift function.

1. Press and hold the  key → [26 RPT ARS] → Press the Right **DIAL** knob.
2. Rotate the Right **DIAL** knob to select the desired setting.

AUTO	The auto repeater shift function is enabled.
OFF	The auto repeater shift function is disabled.

NOTE: This item is registered in the custom function menu by factory setting.

27 RPT SHIFT

Set the direction of the repeater transmit shift setting.

1. Press and hold the  key → [27 RPT SHIFT] → Press the Right **DIAL** knob.
2. Rotate the Right **DIAL** knob to select the shift direction setting.

AUTO	The transmit frequency will not shift.
- RPT	The transmit frequency will shift down.
+ RPT	The transmit frequency will shift up.

28 RPT SHIFT FREQ

Set the repeater transmit shift offset frequency.

1. Press and hold the  key → [28 RPT SHIFT FREQ] → Press the Right **DIAL** knob.
2. Rotate the Right **DIAL** knob to select the desired repeater transmit shift offset frequency.

The offset can be set at 0.05 MHz intervals between 0.00 MHz and 99.95 MHz.

The default setting differs depending on frequency.

29 RPT REVERSE

The “reverse” operation temporarily reverses the transmit and receive frequencies. This permits checking to find if direct communication with the other station is possible.

1. Press and hold the  key → [29 RPT REVERSE] → Press the Right **DIAL** knob.
 - The transmit and receive frequencies are temporarily reversed (“reverse” state).
 - In the “reverse” state, the “-” or “+” blinks on the display.
2. To release the reverse state, repeat the above steps again.

NOTE: This item is registered in the custom function menu by factory setting.

30 MIC PROGRAM KEY

Functions can be assigned to the program keys (P1 to P4) on the provided microphone (SSM-85D).

1. Press and hold the  key → [30 MIC PROGRAM KEY] → Press the Right **DIAL** knob.

Refer to the Operating Manual for details.

31 DATE&TIME ADJUST

Set the date and time of the **FTM-310DR/DE** clock. In the factory default, the date and time are automatically set when acquiring the GPS signals, so in this case no manual setting is necessary.

1. Press and hold the  key → [31 DATE&TIME ADJUST] → Press the Right **DIAL** knob.
2. Press the Right **DIAL** knob to change the year → month → day → hour → minute.
3. Rotate the Right **DIAL** knob to change the setting.
4. When “minute” is set and the Right **DIAL** knob is pressed, the time becomes “00” and the date and time settings are confirmed.

Please note that the setting values will not be saved if the setup menu is exited during setting.

32 DATE&TIME FORMAT

1. Press and hold the  key → [32 DATE&TIME FORMAT] → Press the Right **DIAL** knob.
2. Rotate the Right **DIAL** knob to select [DATE] or [TIME].
3. Rotate the Right **DIAL** knob to change the setting.

DATE	yyyy/mmm/dd, dd/mmm/yyyy, yyyy/dd/mmm, mmm/dd/yyyy
TIME	24 hour / 12 hour

33 TIME ZONE

The **FTM-310DR/DE** clock time can be synchronized for the time zone with the time data (Coordinated Universal Time) from the GPS.

1. Press and hold the  key → [33 TIME ZONE] → Press the Right **DIAL** knob.
2. Rotate the Right **DIAL** knob to select the desired setting.

The time zone can be set at 0.5 hour intervals up to ±14 hours.

The default setting: UTC ±0:00

34 STEP

Set the frequency step when the tuning knob is turned, or when the key is pressed.

1. Press and hold the  key → [34 STEP] → Press the Right **DIAL** knob.

Refer to the Operating Manual for details.

35 CLOCK TYPE

The CPU clock signal can be changed so that an internal spurious signal is not heard by the receiver. Select "A" during normal operation.

1. Press and hold the **FUNC** knob → [35 CLOCK TYPE] → Press the Right **DIAL** knob.
2. Rotate the **FUNC** knob to select the desired setting.

A	The clock shift operation will automatically switch ON and OFF.
B	The clock shift will always be kept in operation.

36 UNIT

Set the units of measure to display the altitude, distance, and speed.

1. Press and hold the  key → [36 UNIT] → Press the Right **DIAL** knob.
2. Rotate the **FUNC** knob to select the desired setting.

INCH	Display units in the Imperial/USA system.
METRIC	Display units in the Metric system.

The default settings depend on the transceiver version.

37 APO

The transceiver can be set to automatically power OFF when there is no operation for a period.

1. Press and hold the  key → [37 APO] → Press the Right **DIAL** knob.
2. Rotate the **FUNC** knob to select the desired setting.

OFF	Does not turn the power OFF automatically.
0.5 hour to 12 hour	Turns the power OFF when no operation is performed for a specified time.

38 GPS DATUM

Set the geodetic GPS positioning standard reference system.

1. Press and hold the  key → [38 GPS DATUM] → Press the Right **DIAL** knob.
2. Rotate the **FUNC** knob to select the desired setting.

WGS-84	Positions using the global geodetic reference system. This is being used as a standard all around the world.
TOKYO MEAN	Positions using the Japanese geodetic reference system. When positioning in Japan (Tokyo), the error can be made smaller.



Select "WGS-84" for the normal operation.

39 GPS LOG

Set the time interval for recording GPS position information to the microSD card.

1. Press and hold the  key → **[39 GPS LOG]** → Press the Right **DIAL** knob.
2. Rotate the Right **DIAL** knob to select the time interval

OFF / 1 sec / 2 sec / 5 sec / 10 sec / 30 sec / 60 sec

If "OFF" is selected, no GPS Information is saved to the microSD memory card.



- Data saved to the microSD memory card is saved in yymmddhhmmss.log format.
- Saved data may be viewed by using OEM PC applications*.

*Yaesu does not provide technical support for PC applications.

AUDIO

40 RECORDING

Set the voice recording function.

1. Press and hold the  key → [40 RECORDING] → Press the Right **DIAL** knob.

Refer to the Operating Manual for details.

41 REC/STOP

Starts or stops voice recording.

1. Press and hold the  key → [41 REC/STOP] → Press the Right **DIAL** knob.

Refer to the Operating Manual for details.

42 REAR SP OUT

Adjust the output level of the main body speaker.

1. Press and hold the  key → [42 REAR SP OUT] → Press the Right **DIAL** knob.
2. Rotate the Right **DIAL** knob to adjust the output level.
0% to **100%** (10% steps)

43 FRONT SP MUTE

Front speaker operation settings when external speakers are connected.

1. Press and hold the  key → [43 FRONT SP MUTE] → Press the Right **DIAL** knob.
2. Rotate the Right **DIAL** knob to select the desired setting.

CONTINUE	The Front speaker audio will not be muted when external speakers are connected.
AUTO MUTE	The Front speaker audio will be muted when external speakers are connected.

SIGNALING

44 DTMF

Select the registered DTMF memory 0 to 9 and press **PTT** to automatically send the DTMF code.

1. Press and hold the  key → **[44 DTMF]** → Press the Right **DIAL** knob.
2. Rotate the **FUNC** knob to select the desired DTMF memory (1 to 9).
3. Press **PTT**.

For details, see “Transmitting DTMF code automatically using DTMF memory” (page 12).

45 DTMF MEMORY

Register the DTMF memory (maximum 16 digits, 9 channels) for automatic transmission with the auto dialer.

1. Press and hold the  key → **[45 DTMF MEMORY]** → Press the Right **DIAL** knob.

For details, see “Registering the DTMF memory” (page 12).

46 SQL TYPE

Selecting the squelch type in the analog FM mode.

1. Press and hold the  key → **[46 SQL TYPE]** → Press the Right **DIAL** knob.

For details, see “Selecting the squelch type in the analog FM mode” (page 6).

47 TONE SQL FREQ / DCS CODE

Set the tone frequency or DCS code.

1. Press and hold the  key → **[47 TONE SQL FREQ]*** or **[47 DCS CODE]*** → Press the Right **DIAL** knob.

*The item name changes automatically depending on the setting of “46 SQL TYPE”.

NOTE: This item is registered in the custom function menu by factory setting.

48 SQL EXPANSION

The squelch type can be set separately for transmit and receive.

1. Press and hold the  key → **[48 SQL EXPANSION]** → Press the Right **DIAL** knob.
2. Rotate the Right **DIAL** knob to select the desired setting.

ON	Add squelch types for signaling.
OFF	Does not add squelch types for signaling.

49 PAGER CODE

The new pager code permits calls to specific stations only.

1. Press and hold the  key → **[49 PAGER CODE]** → Press the Right **DIAL** knob.

For details, see “Setting the Code for this Station” (page 9).

50 PR FREQUENCY

Set a no-communication squelch CTCSS tone from 300 Hz to 3000 Hz in 100 Hz steps.

1. Press and hold the  key → **[50 PR FREQUENCY]** → Press the Right **DIAL** knob.
2. Rotate the Right **DIAL** knob to select the desired CTCSS tone frequency.
300Hz to 3000Hz (100Hz steps)

51 BELL RINGER

The beep may be set to sound an alert when a call is received from another station.

1. Press and hold the  key → **[51 BELL RINGER]** → Press the Right **DIAL** knob.

For details, see “Notification of a Call from a Remote Station by the Bell Function” (page 10).

52 WX ALERT

Setting the weather Alert Feature, to notify of storms and hurricanes, ON or OFF.

1. Press and hold the  key → **[52 WX ALERT]** → Press the Right **DIAL** knob.
2. Press the Right **DIAL** knob to select the desired setting.

ON	Enables the Weather Alert Feature.
OFF	Disables the Weather Alert Feature.

SCAN

53 SCAN

Start or stop scanning for channels in VFO mode or Memory mode.

1. Press and hold the  key → [53 SCAN] → Press the Right **DIAL** knob.

Refer to the Operating Manual for details.

54 DUAL RECEIVE MODE

Activate the Priority Scan function.

1. Press and hold the  key → [54 DUAL RECEIVE MODE] → Press the Right **DIAL** knob.
2. Rotate the Right **DIAL** knob to select the desired setting.

OFF / PRIORITY SCAN

Refer to the Operating Manual for details.

55 DUAL RX INTERVAL

Set the time interval to check for a signal on the priority channel (HOME channel) during the priority scan.

1. Press and hold the  key → [55 DUAL RX INTERVAL] → Press the Right **DIAL** knob.
2. Rotate the Right **DIAL** knob to select the desired setting.

0.5sec / 1.0sec / 2.0sec / 3.0sec / **5.0sec** / 7.0sec / 10sec

Refer to the Operating Manual for details.

56 PRIORITY REVERT

Set to always Transmit on the priority channel (HOME channel) when PTT is pressed during dual receive operation.

1. Press and hold the  key → [56 PRIORITY REVERT] → Press the Right **DIAL** knob.
2. Rotate the Right **DIAL** knob to select the desired setting.

ON	Always send on the priority channel (HOME channel).
OFF	Sends at the currently displayed frequency.

57 SCAN RESUME

Set the time interval to resume scanning after a received signal ends during scanning.

1. Press and hold the  key → [57 SCAN RESUME] → Press the Right **DIAL** knob.
2. Rotate the Right **DIAL** knob to select the desired setting.

BUSY	Continue receiving the frequency until the signal disappears.
HOLD	Stop scanning and receive that frequency.
1 sec / 3 sec / 5 sec	Restart scanning after receiving the frequency for the set amount of time.

The default settings depend on the transceiver version.

DIGITAL

58 DIGITAL POPUP

Set the time duration to display the remote station information (such as the call sign) on the LCD.

1. Press and hold the  key → [58 DIGITAL POPUP] → Press the Right **DIAL** knob.
2. Rotate the Right **DIAL** knob to select the desired setting.

OFF	The remote station information is not displayed.
2 sec - 10 sec - 60 sec	Set the time duration to display the remote station information.
CONTINUE	The remote station information is continuously displayed.

59 LOCATION SERVICE

Set whether to transmit this station position in digital mode.

1. Press and hold the  key → [59 LOCATION SERVICE] → Press the Right **DIAL** knob.
2. Rotate the Right **DIAL** knob to select the desired setting.

ON	Send the location information of this station.
OFF	Do not send the location information of this station.

60 STANDBY BEEP

Set whether or emit the standby beep sound when the remote station completes transmission.

1. Press and hold the  key → [60 STANDBY BEEP] → Press the Right **DIAL** knob.
2. Rotate the Right **DIAL** knob to select the desired setting.

ON	Emits the standby beep sound.
OFF	Does not emit the standby beep sound.

GM

For details on setting each item, refer to “FTM-310DR/DE GM Function Instruction Manual” which is available on Yaesu website.

WIRES-X

For details on setting each item, refer to “FTM-310DR/DE WIRES-X Instruction Manual” which is available on Yaesu website.

70 COM PORT

Set the communication speed and parameters for the COM port DATA jack on the rear panel of the transceiver.

1. Press and hold the  key → **[70 COM PORT]** → Press the Right **DIAL** knob.
The parameter settings screen appears.

SPEED

Setting the communication speed.

1. Rotate the Right **DIAL** knob to select **[SPEED]** then press the Right **DIAL** knob.
2. Rotate the Right **DIAL** to select the desired communication speed then press the Right **DIAL** knob.

The setting switches as follows:

4800bps / **9600bps** / 19200bps / 38400bps / 57600bps

OUTPUT

Select the function of COM port output.

1. Rotate the Right **DIAL** knob to select **[OUTPUT]** then Press the Right **DIAL** knob.
2. Rotate the Right **DIAL** to select the data output type then press the Right **DIAL** knob.

OFF	The COM port is deactivated.
GPS OUT	Outputs the GPS receiver satellite data.
PACKET	Outputs the AX.25 packet data from the internal modem.
WAYPOINT	Outputs the APRS packet WAYPOINT beacon information of other stations acquired from the received data.

WP FORMAT

Set the number of digits for CALLSIGN information of APRS BEACON stations, attached to various data, when WAYPOINT is selected for OUTPUT.

1. Rotate the Right **DIAL** knob to select **[WP FORMAT]** then press the Right **DIAL** knob.
2. Press the Right **DIAL** to select the number of digits of the APRS beacon station call sign information which is added to each data.

NMEA 9	Displays the last 9 digits of the call sign (Example: JA1YOE-14 is output as "JA1YOE-14").
NEMA 8	Displays the last 8 digits of the call sign (Example: JA1YOE-14 is shortened to "A1YOE-14").
NMEA 7	Displays the last 7 digits of the call sign (Example: JA1YOE-14 is shortened to "1YOE-14").
NMEA 6	Displays the last 6 digits of the call sign (Example: JA1YOE-14 is shortened to "YOE-14").

WP FILTER

Sets the type of beacon to be output when “WAYPOINT” is selected in “OUTPUT”.

1. Rotate the Right **DIAL** knob to select [**WP FILTER**] then press the Right **DIAL** knob.
2. Rotate the Right **DIAL** to select the beacon type you want to output then press the Right **DIAL** knob.

ALL	Outputs all the received beacons.
MOBILE	Outputs only mobile station beacons.
FREQUENCY	Outputs only the beacons of stations with frequency information.
OBJECT/ITEM	Outputs only the beacons of object stations or item stations.
DIGIPEATER	Outputs only the beacons of digital repeater stations.
VoIP	Outputs only beacons of VoIP stations such as WIRES.
WEATHER	Outputs only beacons of the weather stations.
YAESU	Outputs only beacons of stations using Yaesu transceivers.
CALL RINGER	Outputs only the information of call sign ringer stations which are set from [81 APRS RINGER (CS)] in the APRS Setup menu.
RANGE RINGER	Outputs only the information of stations recognized as an approaching station by the [80 APRS RINGER] range ringer function in the APRS Setup menu.

71 DATA BAND

Set the operating band of the APRS (internal modem) and data communication (when using the DATA jack at the back of the main body).

1. Press and hold the  key → [**71 DATA BAND**] → Press the Right **DIAL** knob.

APRS

Sets the APRS operating band.

1. Rotate the Right **DIAL** knob to select [**APRS**] then press the Right **DIAL** knob.
2. Rotate the Right **DIAL** to select the APRS operating band, then press the Right **DIAL** knob.

MAIN BAND	Always operate on the Main Band (The band displayed with large numbers is the “Main Band”).
SUB BAND	Always operate on the Sub Band (The band that is indicated in small numbers is the “Sub Band”).
A-BAND FIX	Always operate on the left side band of the display.
B-BAND FIX	Always operate on the right side band of the display.

DATA

Sets the data transmission operating band.

1. Rotate the Right **DIAL** knob to select [**DATA**] then press the Right **DIAL** knob.
2. Rotate the Right **DIAL** to select the DATA communication operating band, then press the Right **DIAL** knob.

MAIN BAND	Always operate on the Main Band (The band displayed with large numbers is the "Main Band").
SUB BAND	Always operate on the Sub Band (The band that is indicated in small numbers is the "Sub Band").
A-BAND FIX	Always operate on the left side band of the display.
B-BAND FIX	Always operate on the right side band of the display.

72 DATA SPEED

Set the baud rate of the APRS (internal modem), and the data communication (when using the DATA jack at the back of the main body).

1. Press and hold the  key → [**72 DATA SPEED**] → Press the Right **DIAL** knob.
The screen for the detailed settings will be displayed.

APRS

Sets the APRS packet communication speed.

1. Rotate the Right **DIAL** knob to select [**APRS**] then press the Right **DIAL** knob.
2. Rotate the Right **DIAL** to select the APRS communication speed, then press the Right **DIAL** knob.

The setting switches as follows:

1200 bps / 9600 bps

DATA

Sets the APRS data communication speed.

1. Rotate the Right **DIAL** knob to select [**DATA**] then press the Right **DIAL** knob.
2. Rotate the Right **DIAL** to select the data communication speed, then press the Right **DIAL** knob.

The setting switches as follows:

1200 bps / 9600 bps

73 DATA SQL

Sets the squelch detection status during APRS (internal modem) operation, and the output status of the squelch terminal of the “DATA” communications jack on the rear panel of the transceiver.

1. Press and hold the  key → [73 DATA SQL] → Press the Right **DIAL** knob
The screen for the detailed settings will be displayed.

APRS

Selects the squelch detection status during APRS operation.

1. Rotate the Right **DIAL** knob to select [**APRS**] then press the Right **DIAL** knob.
2. Rotate the Right **DIAL** to select the desired setting, then press the Right **DIAL** knob.

RX BAND	Does not transmit when the receive band squelch is open.
TX/RX BAND	Does not transmit when either the receive band or transmit band squelch is open.

DATA

Sets the output status (during receive) of the PK SQL (squelch control) terminal (6 pin) on the DATA Jack.

1. Rotate the Right **DIAL** knob to select [**DATA**] then press the Right **DIAL** knob.
2. Rotate the Right **DIAL** to select the desired setting, then press the Right **DIAL** knob.

RX BAND	The SQL terminal is active when the receive band squelch is open.
TX/RX BAND	The SQL terminal is active when either the receive band or the transmit band squelch is open.

TX

Sets the output status (during transmission) of the PK SQL (squelch control) terminal (6 pin) on the DATA Jack.

Sets whether to activate the SQL terminal while the “DATA” set in the Menu “71 DATA BAND” is being transmitted.

When set to “ON”, transmission from an external device such as a TNC may be suppressed while this unit is transmitting in the data band.

1. Rotate the Right **DIAL** knob to select [**TX**] then press the Right **DIAL** knob.
2. Rotate the Right **DIAL** to select the desired setting, then press the Right **DIAL** knob.

ON	The SQL terminal becomes active during transmission.
OFF	The SQL terminal does not become active during transmission.

APRS

The APRS of the transceiver is a communication system for data such as messages and station positions using the APRS format. Refer to the separate Operating Manual APRS Edition for details (download the manual from the YAESU website).

108 BACKUP

The transceiver settings information can be saved to a microSD memory card, also the saved settings can be loaded to the transceiver.

Save the transceiver settings information

Up to 10 items can be saved in each area. If more than 10 items are saved, the oldest information will be overwritten.

1. Press and hold the  key → [108 BACKUP] → Press the Right **DIAL** knob.
2. Rotate the Right **DIAL** knob to select [WRITE TO SD], then press the Right **DIAL** knob.
3. Rotate the Right **DIAL** knob to select the files to be copied, then press the Right **DIAL** knob.

ALL	Copies all data.
MEMORY	Copies only the memory channels and backtrack position information.
SETUP	Copies only the set-up Menu settings.

4. Rotate the Right **DIAL** knob to select [OK], then press the Right **DIAL** knob. When copying is completed, “Completed” and “File name” will be displayed.
 - The file names will be assigned automatically. They cannot be changed.
 - See page 58 for the saved location of each file.

Area to save	File name (up to 10)
ALL	CLNFTM310D to CLNFTM310D09
MEMORY	MEMFTM310D to MEMFTM310D09
SETUP	SYSFTM310D to SYSFTM310D09

Load the transceiver settings information

1. Press and hold the  key → [108 BACKUP] → Press the Right **DIAL** knob.
2. Rotate the Right **DIAL** knob to select [READ FROM SD], then press the Right **DIAL** knob.
3. Rotate the Right **DIAL** knob to select the file to be copied, then press the Right **DIAL** knob.

ALL	Copies all data.
MEMORY	Copies only the memory channels and backtrack position information.
SETUP	Copies only the set-up Menu settings.

4. A list of files saved on the microSD memory card will be displayed.
5. Rotate the Right **DIAL** knob to select the file to be copied, then press the Right **DIAL** knob.
6. Rotate the Right **DIAL** knob to select [OK], then press the Right **DIAL** knob.
7. When loading is complete, “Completed” is displayed on the screen, and then the transceiver automatically restarts.

109 SD INFORMATION

Display information from SD Memory Card.

1. Press and hold the  key → [109 SD INFORMATION] → Press the Right **DIAL** knob.

The bar graph and the following information will be displayed:

Used space : xx,xxx MB

Free space : xx,xxx MB

Capacity : xx,xxx MB

110 SD FORMAT

Initialize a new micro-SD memory card.



Formatting a microSD memory card erases all data saved on it. Before formatting the card, be sure to check for data and save it before formatting.

1. Press and hold the  key → [110 SD FORMAT] → Press the Right **DIAL** knob.
The confirmation screen will be displayed.
2. To format the microSD card, turn the Right **DIAL** knob to select [OK] and then press the Right **DIAL** knob.

Refer to the Operating Manual for details.

OPTION

111 Bluetooth

Make Bluetooth settings and connect to the optional Bluetooth Headset SSM-BT20.

1. Press and hold the  key → [111 Bluetooth] → Press the Right **DIAL** knob.

Refer to the Operating Manual for details.

112 VOICE MEMORY

Make settings related to the (optional) FVS-2 voice guide unit attached to the transceiver.

1. Press and hold the  key → [112 VOICE MEMORY] → Press the Right **DIAL** knob.

Refer to the Operating Manual for details.

113 FVS REC

Start recording the received audio using the (optional) FVS-2 voice guide unit.

1. Press and hold the  key → [113 FVS REC] → Press the Right **DIAL** knob.

Refer to the Operating Manual for details.

114 TRACK SELECT

Select the track to play on the (optional) FVS-2 voice guide unit.

1. Press and hold the  key → [114 TRACK SELECT] → Press the Right **DIAL** knob.

Refer to the Operating Manual for details.

115 FVS PLAY

Plays the audio recorded of the (optional) FVS-2 voice guide unit.

1. Press and hold the  key → [115 FVS PLAY] → Press the Right **DIAL** knob.

Refer to the Operating Manual for details.

116 FVS STOP

Stops playback or recording of the (optional) FVS-2 voice guide unit.

1. Press and hold the  key → [116 FVS STOP] → Press the Right **DIAL** knob.

117 FVS CLEAR

All audio recorded using the (optional) FVS-2 voice guide unit is erased at once.

1. Press and hold the  key → [117 FVS CLEAR] → Press the Right **DIAL** knob.

Refer to the Operating Manual for details.

118 VOICE GUIDE

Use the (optional) FVS-2 voice guide unit to announce the operating frequency by voice.

1. Press and hold the  key → [118 VOICE GUIDE] → Press the Right **DIAL** knob.

Refer to the Operating Manual for details.

CLONE/RESET

119 This → Other

All the data saved on the transceiver directory may be copied (Cloned) to other FTM-310DR/DE transceivers.

For details, see “Copying the Radio Data to another Transceiver” (page 16).

120 Other → This

All the data saved on the transceiver directory may be copied (Cloned) from other FTM-310DR/DE transceivers.

For details, see “Copying the Radio Data to another Transceiver” (page 16).

121 CALLSIGN

The call sign ID registered to the transceiver may be changed using the set menu.

1. Press and hold the  key → [121 CALLSIGN] → Press the Right **DIAL** knob.
The first letter of the call sign ID blinks.
2. Rotate the Right **DIAL** knob to select the desired letter then press the Right **DIAL** knob.
The cursor moves to the right.
 - Up to 10 alphanumeric characters including hyphen and slash may be input.
3. Repeat step 2 to complete to inputting the new call sign.
4. Press and hold the Right **DIAL** knob.

122 MEMORY CH RESET

Delete the registered data from the memory channels.

1. Press and hold the  key → [122 MEMORY CH RESET]
2. Press the Right **DIAL** knob.
The confirmation screen will be displayed.
3. Rotate the Right **DIAL** knob to select [OK], then press the Right **DIAL** knob.
Erase all memory channels and the transceiver will restart.

123 APRS RESET

Reset the APRS setting.

1. Press and hold the  key → [123 APRS RESET] → Press the Right **DIAL** knob.
2. Press the Right **DIAL** knob.
The confirmation screen will be displayed.
3. Rotate the Right **DIAL** knob to select [OK], then press the Right **DIAL** knob.
Erase all APRS settings and it will restart automatically.

124 CONFIG SET

Current all settings can be registered to the preset.

1. Press and hold the  key → [124 CONFIG SET] → Press the Right **DIAL** knob.
2. Press the Right **DIAL** knob.
The confirmation screen will be displayed.
3. Rotate the Right **DIAL** knob to select [OK], then press the Right **DIAL** knob.
“Completed” will be displayed when the preset registration is completed.

125 CONFIG RECALL

Recalls all settings registered in the preset.

1. Press and hold the  key → [125 CONFIG RECALL] → Press the Right **DIAL** knob.
2. Press the Right **DIAL** knob.
The confirmation screen will be displayed.
3. Rotate the Right **DIAL** knob to select [OK], then press the Right **DIAL** knob.
The registered presets will be recalled, “Completed” will be displayed, and then the transceiver will automatically restart.

126 SOFTWARE VERSION

Display the software versions.

1. Press and hold the  key → [126 SOFTWARE VERSION] → Press the Right **DIAL** knob.
The software versions of “Main”, “Sub” and “DSP” are shown.

127 FACTORY RESET

To restore all transceiver settings and memory content to the factory defaults.

1. Press and hold the  key → [127 FACTORY RESET] → Press the Right **DIAL** knob.
The confirmation screen will be displayed.
2. Rotate the Right **DIAL** knob to select [OK] then press the Right **DIAL** knob.
When all information is erased, the transceiver will automatically restart, and the call sign input screen will be displayed.

The folder configuration of the micro-SD card

A commercially available microSD memory card may be inserted into the **FTM-310DR/DE** to save various data files. The parameters of each function are stored in the following folders.

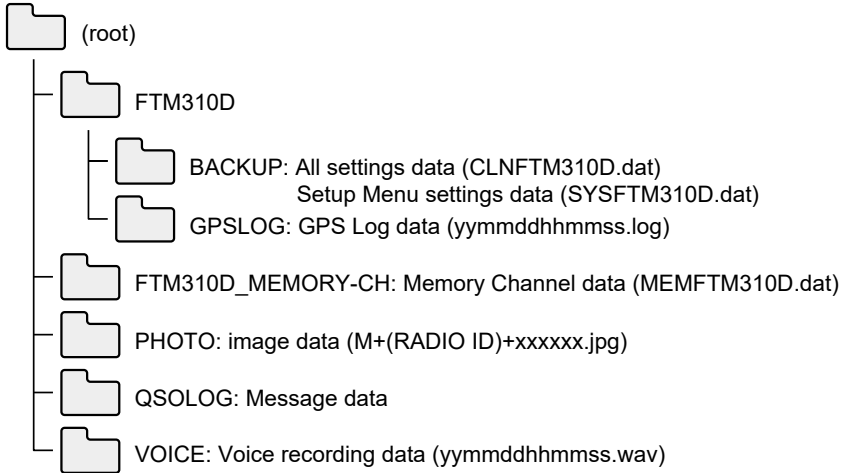

The [yymmddhhmmss] part of the file name consists of year (yy), month (mm), day (dd), hour (hh), minute (mm), and second (ss).

Using the optional Swing Head Kit "SJK-500"

Freely change the angle of the control head up, down, left, or right.

Remove the control head from the transceiver body

To install the SJK-500 Swing Head Kit, remove the control head from the transceiver body.

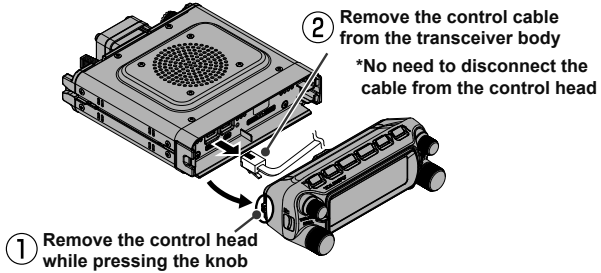

Attach the SJK-500 to the control head

① Peel the release paper off from the spacer and attach the spacer to the control head

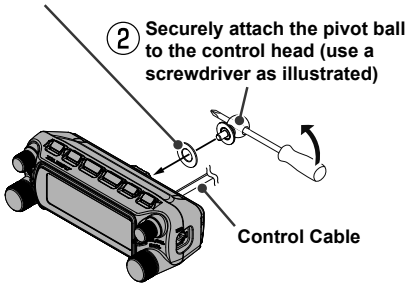

③ Pass the control cable through the hole

④ Loosen the screw so that the pivot ball can fit into the socket

⑤ Insert the pivot ball into the socket

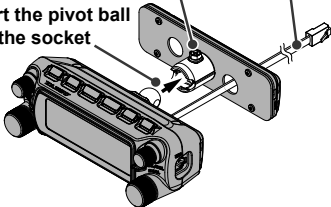

⑥ Connect the control cable to the transceiver body

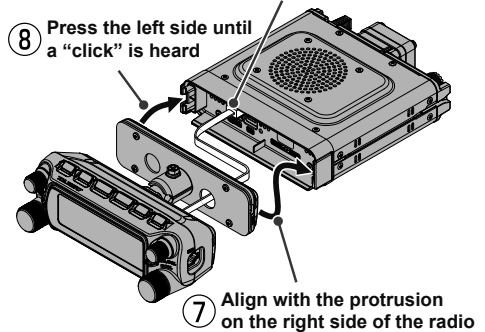

⑨ Adjust the position of the control head and secure it with the set screw

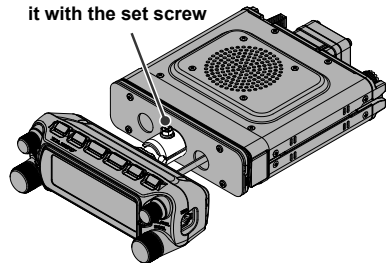

Maintenance

Care and maintenance

Turn the power OFF before wiping away any dust and stains on the transceiver with a dry soft cloth. For stubborn stains, slightly moisten a soft cloth and wring it out before using it to wipe away the stains.



Never use washing detergents and organic solvents (thinner, benzene, etc.). Doing so may result in paint flaking or damage to the transceiver finish.

Replacing the fuse

When the fuse of the DC power supply cable blows and the transceiver becomes inoperable, correct the cause of the problem, and then replace the fuse with a new one of the correct (15 Amp) rating.



When replacing the fuse, be sure to disconnect the power supply cable from the transceiver and from the external DC power supply.

● Replacing the fuse of the DC power supply cable

1. Prepare a new fuse.

Use a fuse with a rating of 15A.



Never attempt to use a fuse that is not of the specified rating

2. Open the fuse holder as shown in the diagram on the right.

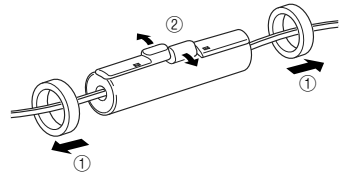

3. Remove the blown fuse.

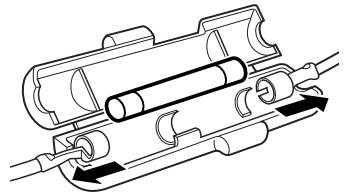

4. Attach the new fuse.
5. Close the fuse holder.

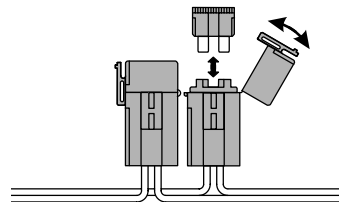

European version

Troubleshooting

Check the following before requesting repair services.

There is no power

- **Is the external power supply connected correctly?**
Connect the black wire to the negative (-) terminal and the red wire to the positive (+) terminal.
- **Is the voltage and current capacity of the external power supply sufficient?**
Check the voltage and current capacity of the external power supply.
Voltage: 13.8V
Current capacity: 15A or higher
- **Is the fuse blown?**
Replace the fuse.

There is no sound

- **Is the squelch level or setting too high?**
Adjust the squelch level when receiving weak signals.
- **Is the volume low?**
Increase the volume by turning the VOL/SQL knob in the clockwise direction.
- **Is the tone squelch or DCS set to on?**
When the tone squelch or DCS is turned on, no sound will be heard until signals containing the set tone frequency or DCS code corresponding to the set code are received.
- **Is the C4FM digital mode on?**
When the AMS function is on, the sound is not output until the transceiver receives an Analog FM mode signal. Also, when the DG-ID function is ON, and the DG-ID number to other than "00", the sound is not output until the transceiver receives a signal with a corresponding DG-ID number.
- **Is the external speaker connected?**
Properly connect a speaker with an impedance of 4 to 16Ω.
- **Is the Bluetooth headset in use?**
Turn OFF the power of the Bluetooth headset, or turn OFF the Bluetooth function in the setup menu.

There is no transmission

- **Is the PTT button pressed properly?**
- **Is the microphone connected correctly?**
Plug the connector all the way into the MIC jack.
- **Is the transmit frequency set to the amateur band?**
Transmission outside the amateur band is not possible.
- **Is the antenna or co-axial cable broken?**
Replace the antenna or co-axial cable.
- **Is the voltage of the external power supply normal?**
When the voltage of the power supply drops during transmission, the transceiver may not run at full performance. Use a stable DC power supply with a voltage of 13.8V and a current capacity of 15A.

The keys or knobs do not operate

- **Is the lock function activated?**
Cancel the lock by briefly pressing the Power switch.

YAESU

Radio for Professionals

Copyright 2025
YAESU MUSEN CO., LTD.
All rights reserved.

No portion of this manual may be
reproduced without the permission of
YAESU MUSEN CO., LTD.

YAESU MUSEN CO., LTD.

Omori Bellport Building D-3F
6-26-3 Minami-Oi, Shinagawa-ku, Tokyo, 140-0013, Japan

YAESU USA

6125 Phyllis Drive, Cypress, CA 90630, U.S.A.

YAESU UK

Unit 4, Concorde Park, Concorde Way, Segensworth North,
Fareham, Hampshire PO15 5FG, United Kingdom